

AP Physics 2 Investigation 1:

Boyle's Law

How can the relationship between pressure and volume for a confined gas be determined experimentally, and how do changes in pressure and volume relate to the work done on this gas?

Central Challenge

The purpose of this investigation is to reinforce the concept of pressure and introduce the idea that the area under a pressure-versus-volume graph of a gas is the work done on or by the gas. The intent is to have students perform this investigation after the topics of pressure and atmospheric pressure have been covered, but before the introduction of pressure-versus-volume (PV) diagrams.

Background

Pressure is a scalar quantity defined as force exerted on a defined area ($P = F/A$). In physics, pressure is usually measured in pascals (Pa, or N/m^2) when force is measured in newtons and area is measured in square meters. In a gas with temperature (T), the molecules are in constant motion. Collisions of the molecules with a container wall result in forces between the wall and the molecules, resulting in changes in the motion of the molecules. The force exerted by the wall on a molecule is equal to the change of the momentum of the molecule with respect to time as defined by Newton's second law ($F = \Delta p / \Delta t$). By Newton's third law, we know that the force on the wall due to the molecule must be equal in magnitude.

The average pressure on a wall of the container is then equal to the average force on that wall due to all of the molecules striking it divided by area of the wall. A change in the temperature of the gas also changes average kinetic energy of the gas ($K = 3/2 nRT$). Thus, because of the relation between kinetic energy and momentum, gas pressure is related to temperature. The ideal gas law ($PV = nRT$) relates gas pressure for a confined gas to the number of moles of gas (n), volume (V), and absolute temperature (T). Gas pressure is exerted equally in all directions and exists within the gas system itself as well as on the walls of the container.

Work done on or by a gas changes the total energy of the gas. In a situation where no energy is allowed to enter or escape a confined gas by thermal processes ($Q = 0$), the work done on or by a gas will result in change in internal energy of the gas, according to the conservation of energy/first law of thermodynamics ($\Delta U = Q + W$). Work done on a gas is defined as a positive quantity in AP Physics, resulting in a compression of the gas ($W = -P\Delta V$). Thus, work done on a confined gas with no thermal energy allowed to enter or escape would result in increased energy of the molecules of the gas. After positive work is done on the gas, its molecules have higher average velocity and momentum and exert larger forces on the walls of the container.

Atmospheric pressure at Earth's surface is due to the combined effect of the gravitational force on the molecules of the atmosphere and is determined to be 1.01×10^5 Pa.

Real-World Application

The concepts of how pressure and volume of a gas relate to each other and to the work done on or by that gas can be used to connect to isobaric, isothermal, and adiabatic processes. A common illustration of thermodynamic processes is the gasoline engine. In each cylinder, a complete cycle consists of four steps or strokes: intake, compression, power, and exhaust. During the intake stroke, the vaporized gasoline–air mixture is drawn into the engine as the piston moves down to increase the space in the cylinder, with the intake valve open and exhaust valve closed. During the compression stroke, both valves are closed, so as the piston moves upward, the gas increases in temperature with the decrease in volume and the spark plug then is timed to ignite the gasoline–air mixture. During the power stroke, the “explosion” of the gasoline vapor from the previous stroke causes rapid expansion of the gas, doing work on the piston to move it downward. In the last stroke, the piston is moved back up with only the exhaust valve open, so the gasoline combustion products are expelled.

Another example that can be demonstrated to students uses a bicycle tire pump. As the handle of the pump is pushed downward to push air slowly into a tire, the handle does work on the gas in the cylinder of the pump, causing the temperature of the air in the pump to increase as the air is compressed. Students can feel the change in temperature of the pump.

A simple illustration of pressure related to volume during an isothermal process occurs when a sealed bag or container becomes visibly greater in volume when the bag is brought from a lower elevation where atmospheric pressure is higher to a higher elevation where atmospheric pressure is lower.

In the study of weather, adiabatic cooling explains cloud formation. When warm, moist air over a body of water on a sunny day rises due to convection, a quick rise in elevation causes rapid expansion of the air due to lower pressure — with no addition or removal of energy. As the air temperature decreases due to rapid expansion, the moisture condenses to form a cloud.

Inquiry Overview

In this investigation, students use a Boyle's law apparatus (see Figure 1) to investigate the relationships between pressure, volume, force, and work done on a gas. Students use different known forces to compress the gas and measure the change in volume as more force is used to compress the gas. The data will be used to produce and analyze a graph of gas pressure as a function of volume, using the assumption that the air in this experiment approximates an ideal gas.

Equipment is provided, along with fairly specific directions needed for data gathering, so this lab is on the “directed” side of guided inquiry. Students should still be given as much latitude as possible in determining how to make measurements and design their analysis methods. However, without some clear directions, they can easily make major errors that lead to confusion. Open inquiry is preferable, but this guided-inquiry lab can reinforce important concepts on a challenging topic. Allow latitude while maintaining vigilance, watching and making suggestions to steer students in the right direction as they do their prelab conferencing and as they work.

Connections to the AP Physics 2 Curriculum Framework

Big Idea 5 Changes that occur as a result of interactions are constrained by conservation laws.

Enduring Understanding

Learning Objectives

5.B The energy of a system is conserved.

5.B.5.4 The student is able to make claims about the interaction between a system and its environment in which the environment exerts a force on the system, thus doing work on the system and changing the energy of the system (kinetic energy plus potential energy). (Science Practices 6.4 and 7.2)

5.B.5.5 The student is able to predict and calculate the energy transfer to (i.e., the work done on) an object or system from information about a force exerted on the object or system through a distance. (Science Practices 2.2 and 6.4)

5.B.5.6 The student is able to design an experiment and analyze graphical data in which interpretations of the area under a pressure-volume curve are needed to determine the work done on or by the object or system. (Science Practices 4.2 and 5.1)

5.B.7.1 The student is able to predict qualitative changes in the internal energy of a thermodynamic system involving transfer of energy due to heat or work done and justify those predictions in terms of conservation of energy principles. (Science Practices 6.4 and 7.2)

Enduring Understanding**Learning Objectives**

5.B.7.2 The student is able to create a plot of pressure versus volume for a thermodynamic process from given data. (Science Practice 1.1)

5.B.7.3 The student is able to use a plot of pressure versus volume for a thermodynamic process to make calculations of internal energy changes, heat, or work, based upon conservation of energy principles (i.e., the first law of thermodynamics). (Science Practices 1.1, 1.4, and 2.2)

[NOTE: In addition to those listed in the learning objectives above, Science Practice 4.3 is also addressed in this investigation.]

Skills and Practices Taught/Emphasized in This Investigation

Science Practice**Activities**

1.1 The student can *create representations and models* of natural or man-made phenomena and systems in the domain.

Students create diagrams of their experimental piston setup as part of the lab report. They create a free-body diagram of the piston in order to examine the forces exerted by the atmosphere by the added weights and by the gas on the piston. They also create at least one pressure–volume graph to represent the change in volume with increased pressure.

1.4 The student can *use representations and models* to analyze situations or solve problems qualitatively and quantitatively.

Students analyze their pressure–volume graph to determine the work done on the system. An extension might include analyzing the meanings of the slope and intercept of the PV graph as well. They use the free-body diagram representation to examine and calculate force.

2.2 The student can *apply mathematical routines* to quantities that describe natural phenomena.

Students use mathematical equations to calculate the area of the piston and the volume of gas for each change in height. Students use area under the PV graph to calculate work done on the system by the external force.

4.2 The student can *design a plan* for collecting data to answer a particular scientific question.

Though clear directions need to be provided, students make decisions about measurement and graphing techniques. They determine in what increments measurements will be made in order to produce a meaningful graph.

4.3 The student can *collect data* to answer a particular scientific question.

Students make multiple measurements of force to determine pressure and measurements of change in column height to determine change in volume.

5.1 The student can *analyze data* to identify patterns or relationships.

Students analyze the data graphically, determining the meaning of graph area to find work done on the system.

Science Practice

6.4 The student can *make claims and predictions about natural phenomena* based on scientific theories and models.

Activities

As part of the background and preparation of the lab, students make predictions about how gas volume changes with increasing pressure on the piston. Then, as part of the analysis, students discuss at least one everyday situation in which gas pressure and volume variations are important (such as in the piston-cylinder system of an automobile).

[NOTE: Students should be keeping artifacts (lab notebook, portfolio, etc.) that may be used as evidence when trying to get lab credit at some institutions.]

Equipment and Materials

Per lab group (two to four students):

- ▶ Boyle's law apparatus (see Figure 1 below)
- ▶ Mass scales
- ▶ Rulers
- ▶ Graph paper or graphing calculator
- ▶ Objects with mass large enough to compress the air in the syringe (such as books, small bricks, or any other objects that are heavy enough and can be stacked on top of the Boyle's Law apparatus)
- ▶ (Optional) Pressure sensor that can be inserted directly into the lower chamber of the syringe, allowing students to measure pressure changes directly to plot against volume



Figure 1: Boyle's Law Apparatus

[NOTE: The Boyle's law apparatus can be purchased from most science supply companies for less than \$15 depending on the supplier and quality of the apparatus. It is also possible to build your own by looking at Figure 1 and other designs shown online.]

There is an alternative setup that involves the masses hanging from the syringe instead of being stacked on top. This apparatus is available from several science supply companies for less than \$15.00 and is illustrated in Figure 2.

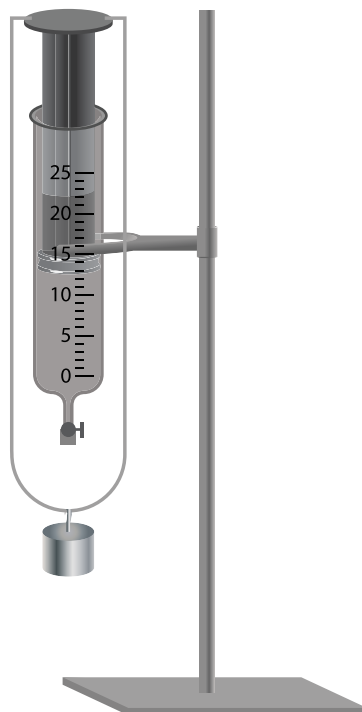

Figure 2: Boyle's Law Apparatus (Alternate)

[NOTE: This investigation works best when the piston of the Boyle's law apparatus has been well lubricated. If not, there will be too much friction between the piston and the walls of the syringe, which will greatly affect the results.]

Timing and Length of Investigation

- ▶ **Teacher Preparation/Set-up:** 5–10 minutes

This time is for gathering the equipment. More time will be needed if you also setup the equipment for students.

- ▶ **Student Investigation:** 35–50 minutes

Prediction/Setup/Observation Time: 10–15 minutes

Data Collection/Calculations: 15–20 minutes. This time includes weight, piston area, and pressure calculations.

Graphing/Calculations: 10–15 minutes, depending on whether the graph is done by hand or on a graphing calculator (includes calculations of area under the graph).

▶ **Postlab Discussion:** 10–15 minutes

If fitting this investigation into a shorter class period (50–55 minutes) is an issue, have the Prediction/Setup/Observation portion done on one day (or assign the writing of the prediction and observations as homework), and complete the rest of the investigation the next day (or assign graphing and analysis of the graph as homework).

▶ **Total Time:** approximately 1 hour

Safety

The largest safety issue is the danger of the objects that are stacked on top of the Boyle's law apparatus falling over. The more objects stacked on top, the less stable the apparatus becomes. Students should take care in preventing this from happening as they add objects.

Preparation and Prelab

Prior to the lab, students should understand the concept of gas pressure and how it relates to the kinetic theory of gases, as well as how to calculate pressure on a surface in terms of force and area using the equation $P = F/A$. They should know how atmospheric pressure is determined and be ready to apply the concept of equilibrium to the initial condition where atmospheric pressure and gas pressure are equal. The basic relationships among pressure, volume, and temperature as defined by the ideal gas law should be familiar enough that students can use $PV = nRT$ to make descriptions and calculations. You might need to prompt students with the reminder that the pressure of the gas in the cylinder is the sum of the pressure produced by the weight added to the cylinder and atmospheric pressure. (In other words, when no additional weight has been added to the top of the piston, the gas pressure is equal to the atmospheric pressure. Students will need to decide whether it is reasonable to assume that the piston itself has a small enough mass to neglect.)

You could assign practice problems from the textbook that include calculations with the ideal gas equation and with pressure and area concepts and calculations. Additionally, "Gas Properties" is an interactive simulation that would help students develop an understanding of the relationship between pressure and volume at constant temperature (see reference to the PhET web site in Supplemental Resources). The PhET site also has teacher-prepared student activities that can be used as homework or used in class for formative assessment in preparation for the lab.

The Investigation

Select from the options below the method that might best fit the equipment available in your school or the experience level of students (or yourself). It is up to you to determine whether students should choose a method themselves or should be directed to a specific method.

For a student-designed, inquiry-based lab:

Each lab group should decide how they will setup the equipment to gather the necessary data, how many data sets they need, and the increments in which they will measure the data to create the best graphical representation of that data. Students should think about experimental control (i.e., how they will prevent energy transfer into or out of the apparatus during data gathering). If students decide to use pressure probes, they need to consider how the probes can be used without allowing gas molecules to enter or leave the gas during the experiment.

Encourage students to examine the situation and then draw a free-body diagram of the forces on the piston in the Boyle's law apparatus in order to realize that if the piston reaches equilibrium after each additional mass is added to the top of the piston, the total force on the top (Mg + atmospheric pressure) must be equalized with the gas pressure from the inside of the container.

Students also need to consider how they will add weight to the top of the piston so that stability is maintained. Most will decide to carefully select and add calibrated masses to the top of the piston, recording the value of the added mass (m) for each trial as they carefully measure the change in height (Δh) of the piston. Later, they will use the change in piston height, along with radius of the piston, to calculate change in volume of the gas ($\Delta V = \pi R^2 \Delta h$).

Consider giving students the following guiding questions: "What is the relationship between pressure and change in volume for a gas?" "What does the area under a pressure vs. volume (PV) graph of a gas represent?" Whatever experimental design is chosen, students must collect data and evidence to answer the questions and come up with their own procedure and draw their own conclusions based on the results. Students must then construct a graph to analyze data and answer the experimental question regarding work. They will need to do research to determine what equations are necessary for analysis of data.

[NOTE: Many students have had experience with the Boyle's law apparatus in their chemistry classes, so they may decide to use that apparatus and come up with their own design, with little prompting. Others that are aware that the school has pressure probes may decide to measure gas pressure directly.]

For a more directed student inquiry:

Depending on the experience and skill level of the group, a more directed student inquiry may be more appropriate. You might want to do a quick demonstration of how the apparatus is setup. Then give students directions, as needed, providing further prompts as necessary for each group to progress. Show students the equipment to use, and have them do the following:

1. Measure the radius of the plunger in the syringe.
2. Measure the mass of each object as the objects are stacked on top of the Boyle's law apparatus.
3. Measure the volume of the air in the syringe as the objects are added.
4. Record all data.

Extension

Once students have discovered the inverse relationship between pressure exerted on the gas and volume of the gas, ask them how they might graph the data to create a linear graph. Once they decide that a plot of pressure versus the reciprocal of volume would create a linear graph, ask about the meaning of the slope of the graph and the intercept. Since $PV = nRT$, the slope would be nRT , assuming temperature stays constant, and the intercept (where volume is zero) is also the point where the pressure is zero. (Students should not extend their experiment line to the origin, since that would indicate a zero volume and pressure.)

Students may investigate how temperature varies with the changes in pressure and volume during this experiment by installing a thermometer or temperature probe directly into the chamber of the piston. For this extension, they pull the apparatus apart and use a drill or hot soldering iron to create a hole just barely larger than the thermometer or probe. After the probe is inserted into the chamber, they carefully seal the opening with wax so that air molecules cannot enter or escape during the compression process. Then they reassemble the apparatus and conduct the experiment as done previously, with temperatures recorded during each step along with pressure and volume.

Common Student Challenges

The largest challenge to students (or cause of the most common error made by students) is not including the atmospheric pressure in their calculations for the pressure on the plunger in the syringe. If this is not included there is a large error in their results. Ask students, “What is the pressure of the gas in the cylinder before any objects are added to the top of the piston?” If it is pointed out that the gas and piston are, indeed, in equilibrium, students are more likely at each step to realize that the gas pressure is equal to the total pressure exerted on it, which is the atmospheric pressure plus the additional pressure exerted by the mass added to the top of the piston. This is a very common source of error for students, and something you might need to bring out both in prelab preparation and in the postlab discussion.

When students get ready to graph their results, they might need to be reminded that the pressure is not zero when the piston is in its starting position. The pressure is equal to the atmospheric pressure.

This challenge could also be addressed by having students draw a free-body diagram of the apparatus in equilibrium with air in the syringe before any masses are added along with a discussion about what forces are acting on the gas without any masses stacked on top.

Students who have large margins of error in their measurements will have difficulty in connecting the area under the PV graph to the work done by gravity pulling on the object sitting on the piston, which is equivalent to the work done on the gas in the cylinder. Encourage students and/or remind them to take measurements as accurately and precisely as possible — and in small increments — to ensure greater success in their results.

If students are advised that the apparatus without weights added to the top is a system in equilibrium, then it may be easier for them to understand that they are taking data for *changes* in the system (i.e., as they add more weight to the top of the piston, the volume changes until a new equilibrium is established).

Students may have some difficulty with the requirement to graph pressure versus volume, since they are actually using change in applied pressure as the independent variable. However, they will graph gas pressure as a function of volume, which is the conventional way of analyzing these changes.

Students may have some difficulty recognizing that the graph of pressure versus volume is a hyperbola. Depending on student level, you might need to include, at the least, a reminder of what such a curve means in terms of the variables ($P \propto 1/V$), and, if needed, a brief lesson on how to determine that a curve is a hyperbola (i.e., that the product of coordinates at each point is constant). It may be easier for students to understand if they rearrange the equation $PV = nRT$ into the linear $y = kx + b$ form. By putting P on the y -axis, the equation takes the form $P = (nRT)/V$. It is assumed that the changes in pressure and volume take place slowly enough that the temperature of the gas remains constant — an isothermal process. Then it's easier for students to see that by graphing P versus $1/V$, the resulting graph is linear, with the values of n , R , and T assumed to be constant. [NOTE: You can decide how much of this prompting is necessary prior to the lab and how much can occur as students process the data.]

Analyzing Results

After the lab, students meet in small groups to develop strategies to answer the questions posed by the experiment. After calculating the new volume of the gas and the new pressure on the gas each time mass is added to the top of the piston, they decide how to graph the pressure–volume data to make conclusions about the relationship between pressure and volume. This should be left to students, though they may need prompting if they get stuck on the hyperbolic curve shape and how to interpret it (as mentioned earlier).

Once they find the curve, they design a plan to find the area under the curve. Solutions may range from “counting squares” to making a best fit line that includes and excludes approximately equal areas to using a graphing program like Excel to find and integrate the equation. Again, you can decide how much prompting is necessary for students to succeed in this.

Students should include the following steps in their calculations:

1. Calculate the pressure exerted on the plunger by the objects as each object is added, using gravitational force on the objects and the area of the plunger. **[NOTE: Students will likely assume the mass of the piston is negligible.]**
2. Plot the data of pressure and volume on a PV graph with the pressure on the y-axis and volume on the x-axis and draw a best-fit curve through the data.
3. Calculate/estimate the area under the graph. This could be done by hand on a sheet of graph paper and counting squares to obtain the area or with a graphing calculator and using the calculator to find the area. Calculate the total change in gravitational potential energy of the added objects during the experiment and the total change in volume of gas to calculate a comparison of work done on the gas (force times distance).
4. Then compare the area under the graph to the change in gravitational potential energy (work done by the mass) and notice that they are approximately the same.

The following equations should be provided for this investigation:

$$P = \frac{F}{A}$$

[Equation 1]

$$A = \pi r^2$$

[Equation 2]

$$F_g = Mg$$

[Equation 3]

$$\Delta U_g = Mg\Delta y$$

[Equation 4]

The following equation is the result students should derive for calculating the pressure on the syringe plunger due to the added objects:

$$P = \frac{Mg}{\pi r^2}$$

[Equation 5]

Ask students to predict the shape of the resulting graph by sketching a graph. You can also ask them to make a prediction about what quantity they think would be represented by the area under the PV graph. Another discussion that should be part of the lab analysis is how students accounted for atmospheric pressure on the apparatus and the effect of the weight of the plunger.

Students should compare their observations to the predictions made at the beginning of the investigation. If their prediction does not match their observations, ask them to explain/resolve the inconsistencies. You can also ask the students to identify errors, identify the largest source of error, and explain what can be done to minimize the identified error(s) if they were to perform the investigation again. This is the time to ask students how they took into account the mass of the plunger in their experimental design.

As time permits after the lab experiment is performed, small student working groups can report their results to the group at large, obtain feedback from the other groups, and close the “learning loop.” Whether done in this group format or in individual lab reporting, students should be required on every lab to summarize sources of uncertainty (not necessarily calculations) and describe how those uncertainties might have affected final calculations or analyses. For example, in this lab, the syringe may leak air during the compression, reducing the number of moles of gas in the syringe during the experiment. This would cause a larger reduction of volume with each compression as the experiment progresses.

Assessing Student Understanding

After completing this investigation, students should be able to:

- ▶ Calculate pressure in terms of force and area;
- ▶ Calculate change in volume in terms of change in height of piston and area;
- ▶ Describe the equilibrium condition of the piston using a free-body diagram;
- ▶ Describe the equilibrium condition of the piston without added objects as a balance of gas pressure with atmospheric pressure;
- ▶ Recognize the hyperbolic shape of the PV curve as an inverse relationship;
- ▶ Determine the area under a PV graph;
- ▶ Relate the area under the PV graph to the work done on or by the gas;
- ▶ Explain how they got values for the pressure of the gas (unless it was measured directly);

- ▶ Recognize why they must take into account atmospheric pressure; and
- ▶ Recognize the role of friction between the piston and the cylinder wall as a source of uncertainty.

[NOTE: Some assessment questions could be based on the “Gas Properties” simulation (see Supplemental Resources). Also on the PhET website are additional activities as well as clicker questions that relate to this investigation.]

Assessing the Science Practices

Science Practice 1.1 The student can *create representations and models* of natural or man-made phenomena and systems in the domain.

Proficient	Creates an accurate and appropriate graph of the relationship between pressure exerted on the gas and volume of the gas, and creates an accurate free-body diagram of the forces exerted on the piston.
Nearly Proficient	Creates a free-body diagram that contains one or more erroneous forces, or creates a graph of pressure and volume that has a flaw in the representation of the relationship between pressure exerted on the top of the piston and volume change in the piston; one of the representations is correct.
On the Path to Proficiency	Creates a free-body diagram, but it has a conceptual error. Creates a graph of pressure and volume that is a flawed or an incomplete representation of the relationship between pressure exerted on the top of the piston and volume change in the piston.
An Attempt	Unsuccessfully attempts either the free-body diagram or the graph.

Science Practice 1.4 The student can *use representations and models* to analyze situations or solve problems qualitatively and quantitatively.

Proficient	Creates and uses both the free-body diagram and the pressure–volume graph to correctly analyze forces on the piston and correctly determine work done on the gas.
Nearly Proficient	Creates a correct free-body diagram but doesn't use the diagram to make correct inferences about forces on the piston, or makes the pressure–volume diagram but makes errors in using the area to determine work done on the gas.
On the Path to Proficiency	Creates a correct free-body diagram but doesn't use the diagram to make correct inferences about forces on the piston. Creates a pressure–volume diagram but makes errors in using the area to determine work done on the gas.
An Attempt	Makes an attempt but doesn't use the free-body diagram to make correct inferences about forces on the piston. Unable to use a pressure–volume diagram to correctly determine area and the meaning of area.

Science Practice 2.2 The student can *apply mathematical routines* to quantities that describe natural phenomena.

Proficient	Correctly calculates all pressures for data gathered and correctly plots the pressure–volume graph and the area under the graph.
Nearly Proficient	Calculates pressure on the piston in terms of area and calculates area under the pressure–volume graph, but there are mathematical errors in one of the calculations.
On the Path to Proficiency	Makes an attempt to calculate pressure on the piston in terms of area and calculate area under the pressure–volume graph, but there are some mathematical errors in both calculations.
An Attempt	Makes an attempt to calculate pressure but there are significant errors.

Science Practice 4.2 The student can *design a plan* for collecting data to answer a particular scientific question.

Proficient	Creates a design that is thorough, producing meaningful data and a plan for analysis that will answer the questions posed by the experiment; for example, explains how values for the pressure of the gas (which may not be measured directly) were obtained, recognizes why atmospheric pressure must be taken into account in the design, and recognizes the role of friction of the piston as a source of error.
Nearly Proficient	Creates an experimental design that is generally good but with an omission that makes graphing or calculations difficult, such as omitting units on measurements. Partially addresses the experimental factors important to the results (e.g., atmospheric pressure, determination of pressure from other measurements, and the uncertainty produced by friction).
On the Path to Proficiency	Creates an experimental design that is generally useful but has numerous flaws; for example, forgets to record units on measurements and neglects to record initial volume of the gas, making calculations from those measurements impossible.
An Attempt	Attempts a setup for this experiment but the experimental design will not produce useful data; for example, the design may include gathering data for mass and height with no plan to calculate pressure and volume.

Science Practice 4.3 The student can *collect data* to answer a particular scientific question.

Proficient	Collects adequate data for added weight and volume change, and analysis includes relevant, accurate discussion of the precision and measurement uncertainty.
Nearly Proficient	Collects adequate data for added weight and volume change and there's some discussion of uncertainty, but the discussion is irrelevant or inaccurate.
On the Path to Proficiency	Collects adequate data for added weight and volume change, but data lacks any discussion of precision or uncertainty in measurements.
An Attempt	Collects some data for added weight and volume change, but data is minimal and not organized well enough to create a meaningful graph.

Science Practice 5.1 The student can *analyze data* to identify patterns or relationships.

Proficient	Creates the pressure–volume plot, correctly determines the inverse relationship between pressure and volume, and correctly determines the area under the plot, relating it to work done.
Nearly Proficient	Creates the pressure–volume plot and determines the inverse (hyperbolic) relationship but is unable to correctly relate this to the mathematical trend; or, is unable to correctly determine the area under the graph.
On the Path to Proficiency	Creates a pressure–volume plot but has not found the hyperbolic relationship, or has the hyperbola but has made no attempt to explain what the shape means in terms of pressure and volume changes.
An Attempt	Attempts a graph, but the data is too scattered or not enough data sets are gathered to produce a meaningful graph.

Science Practice 6.4 The student can *make claims and predictions about natural phenomena* based on scientific theories and models.

Proficient	Makes a prediction based on scientific models, ties it to a real-world example, uses his or her prediction to compare to experiment to identify inconsistencies, and makes a physically significant connection to explain them.
Nearly Proficient	Makes a prediction based on scientific models and may tie it to a real-world example but the connection is not strong, or uses his or her prediction to compare to experiment to identify inconsistencies, but fails to make a physically significant connection to explain them.
On the Path to Proficiency	Makes a prediction based on scientific models but does not tie it to any real-world example or use it to consider inconsistencies to be resolved in the investigation.
An Attempt	Makes a prediction but it seems to be more of a guess, not based on scientific models.

Supplemental Resources

De Berg, Kevin Charles. “Student Understanding of the Volume, Mass, and Pressure of Air Within a Sealed Syringe in Different States of Compression.” *Journal of Research in Science Teaching* 32, no. 8 (1995): 871–884. [These papers give some research background into pertinent student ideas.]

“Gas Properties.” PhET. University of Colorado Boulder. Accessed September 1, 2014. <http://phet.colorado.edu/en/simulation/gas-properties>.

Kautz, Christian H., Paula R. L. Heron, Michael E. Loverude, and Lillian C. McDermott. “Student Understanding of the Ideal Gas Law, Part I: A Macroscopic Perspective,” *American Journal of Physics* 73, no. 11 (2005): 1055–1063.

Loverude, Michael E., Christian H. Kautz, and Paula R. L. Heron. “Student Understanding of the First Law of Thermodynamics: Relating Work to the Adiabatic Compression of an Ideal Gas.” *American Journal of Physics* 70, no. 2 (2002): 136–148.

McDermott, Lillian C., Peter S. Shaffer, and the Physics Education Group at the University of Washington. “Ideal Gas Law. First Law of Thermodynamics.” In *Tutorials in Introductory Physics*. Upper Saddle River, NJ: Pearson, 2012. [Contains two guided inquiry tutorials based on Michael Loverude’s and Chris Kautz’ Ph.D. dissertations that are intended to address student difficulties with topics of this lab.]

Meltzer, David E. “Investigation of Students’ Reasoning Regarding Heat, Work, and the First Law of Thermodynamics in an Introductory Calculus-Based General Physics Course.” *American Journal of Physics* 72, no. 11 (2004): 1432–1446.

Robertson, Amy D., and Peter S. Shaffer. “University Student and K-12 Teacher Reasoning about the Basic Tenets of Kinetic-Molecular Theory, Part I: Volume of an Ideal Gas.” *American Journal of Physics* 81, no. 4 (2013): 303–312.

“Special Focus: Graphical Analysis.” AP Physics 2006–2007 Professional Development Workshop Materials. College Board. Accessed September 1, 2014. http://apcentral.collegeboard.com/apc/public/repository/AP_Physics_Graphical_Analysis.pdf.

AP Physics 2 Investigation 2: Fluid Dynamics

What is the mathematical relationship between the depth of a fluid in a container and the rate at which the fluid will move through an opening near the bottom?

Central Challenge

In this lab, students establish and investigate the relationship between water level in a container and the rate at which it exits through a hole near the base. The investigation provides practice with experimental design, data collection, and graphical analysis. All of these practices can be accomplished with varying degrees of sophistication depending on the equipment available.

Background

Pressure due to a static fluid is ρgh , depending only on the density and depth of the fluid but not on the total volume of fluid. The total force can be calculated by multiplying pressure by area ($F = PA$). Pascal's principle states that at any depth in a fluid, the pressure is exerted by the fluid equally in all directions. As a consequence, an object fully or partially submerged in a fluid has an upward, buoyant force exerted on it that is equal to the weight of fluid displaced by the object — a statement of Archimedes' principle.

Bernoulli's equation describes conservation of energy as applied to fluids in motion. The sum of the terms ($P + \rho gh + \frac{1}{2} \rho v^2$) remains constant at every point throughout the fluid. In the equation, P is pressure, ρ is the density of the fluid, g is the constant gravitational acceleration near Earth's surface, h is the depth of the fluid, and v is the speed of the fluid. The conservation of energy statement by this equation becomes more apparent to students if each term is multiplied by volume, so that the first term becomes PV (or work), the second term becomes mgy (potential energy) and the third term becomes $\frac{1}{2} mv^2$ (kinetic energy).

The continuity equation, $\rho_1 A_1 v_1 = \rho_2 A_2 v_2$, describes how the speed of fluid flow changes with cross sectional area for any two points in level fluid flow and is a statement of conservation of mass in fluid flow. If the fluid is incompressible so that density can be assumed to remain constant, the density cancels on both sides, reducing the equation to its simpler form: $A_1 v_1 = A_2 v_2$.

Real-World Application

Bernoulli's principle (conservation of energy) can be used in medicine to understand blood pressure, helping students to understand that when blood vessels change in diameter the speed of blood flow and pressure change.

Bernoulli's principle applies in engineering to help explain, for example, the lift provided by the wings of aircraft and the driving force on the sails of boats. In both cases, air moving along the more curved surface (such as the upper surface of an airfoil) has a higher speed than the air moving on the opposite surface. Since the fluid in both cases is air, the difference in pressure due to the depth of fluid relative to Earth between the two sides of a wing or sail is negligible. Thus, the only two terms to consider in the equation are the pressure term and the term containing speed. By conservation of energy, then, as the speed increases at one point in the fluid, the pressure decreases. That difference in pressure between two points — the upper and lower surfaces of a wing or the windward and leeward sides of a sail — creates a net force, which is $F = \Delta PA$.

As a fundamental description of fluids in motion, there is almost unlimited application. This law also explains the fact that advanced gasoline engines use pumps rather than “gravity feed,” as it would be undesirable to have the rate of delivery of fuel depend on the depth of the fluid in the tank (as exemplified by this experiment). Using gravity feed, the rate of fuel delivery would depend on the depth of fuel in the tank. In newer engines, an electric pump delivers fuel at a constant pressure (regardless of depth of fuel in the tank), increasing engine efficiency.

Inquiry Overview

This investigation is designed to be guided inquiry, with the teacher providing materials and instructions and students taking the responsibility for laboratory setup and the design for data gathering and processing. Using any one (or more) of the three methods described here, depending on equipment available, students design an experiment to measure the rate of flow of water from the container either by (a) measuring the depth of water as a function of time, (b) measuring the speed of the water as it exits the hole as a function of time (using the distance the water lands from the container and doing kinematics calculations), or (c) using video analysis.

Connections to the AP Physics 2 Curriculum Framework

Big Idea 5 Changes that occur as a result of interactions are constrained by conservation laws.

Enduring Understanding	Learning Objectives
5B The energy of a system is conserved.	5.B.10.1 The student is able to use Bernoulli's equation to make calculations related to a moving fluid. (Science Practice 2.2)
	5.B.10.2 The student is able to use Bernoulli's equation and/or the relationship between force and pressure to make calculations related to a moving fluid. (Science Practice 2.2)
	5.B.10.3 The student is able to use Bernoulli's equation and the continuity equation to make calculations related to a moving fluid. (Science Practice 2.2)
	5.B.10.4 The student is able to construct an explanation of Bernoulli's equation in terms of the conservation of energy. (Science Practice 6.2)
5F Classically, the mass of a system is conserved.	5.F.1.1 The student is able to make calculations of quantities related to flow of a fluid, using mass conservation principles (the continuity equation). (Science Practice 2.1, 2.2, and 7.1)

[NOTE: In addition to those listed in the learning objectives above, Science Practice 4.3 is also addressed in this investigation.]

Skills and Practices Taught/Emphasized in This Investigation

Science Practices	Activities
2.1 The student can <i>justify the selection of a mathematical routine</i> to solve problems.	Students decide which equations to use to make calculations from their data. For example, if they choose to measure the horizontal distance water travels as it exits a container and also measure the depth of water above the exit, they use a modified version of Bernoulli's equation, along with kinematics equations related to projectile motion.
2.2 The student can <i>apply mathematical routines</i> to quantities that describe natural phenomena.	Students apply mathematical routines to make the calculations as described above, and then in the experimental analysis relate results to a natural phenomenon, such as using the distance water lands from the base of a waterfall to the speed of the water at the top.
4.3 The student can <i>collect data</i> to answer a particular scientific question.	Students decide what measurements to take, depending on their experimental design, to answer the question of how the speed of the water at the exit hole compares to depth of the water above it and how far horizontally the water travels.
6.2 The student can <i>construct explanations of phenomena based on evidence</i> produced through scientific practices.	In the analysis of this experiment, students explain their measurement and conclusions in terms of conservation of energy and conservation of mass.
7.1 The student can <i>connect phenomena and models</i> across spatial and temporal scales.	In the analysis, students connect their experimental results on the laboratory scale to at least one common example — either on a smaller scale (such as application to the venturi valve in a carburetor) or on a larger scale (such as using photos of a waterfall to relate height and trajectory of the water to the speed of the water).

[NOTE: Students should be keeping artifacts (lab notebook, portfolio, etc.) that may be used as evidence when trying to get lab credit at some institutions.]

Equipment and Materials

Per lab group (three to four students):

- ▶ Plastic transparent bottle or discharge container with largely vertical walls (such as soda or juice bottles of at least 1-liter volume; smaller containers might produce issues of precision).
- ▶ Masking tape (one roll)
- ▶ Metric rulers/metersticks
- ▶ Stopwatch or cell phone/computer with a stopwatch program (Timers available on many cell phones allow continuous recording of the times for each measurement of height as the water level falls.)

- ▶ Container to catch the water (large enough so that the stream of water will strike it from the extreme of the trajectory to just below the hole itself; sinks large enough to contain the trajectory are ideal, but large buckets or plastic bins will work)
- ▶ Graphical analysis program on a computer or calculator
- ▶ (Optional) Video cameras (or smartphones, etc.) and video analysis software

Making the discharge containers

In order to reduce the effects of turbulent flow, the hole should be circular with smooth edges. A round hole with smooth edges can be most easily produced in the lower side of the bottle by using the round tip of a hot soldering iron. You might want to prepare the bottles in this way ahead of time. Care should be taken that the hole is made perpendicular to the bottle so the stream emerges in a horizontal direction (see Figure 1 below). If bottles need to be transported once they are filled with water, you may want to use a stronger tape (e.g., duct tape) to cover the holes, or simply keep the caps on the bottles. (It is left to students to discover that the water won't leave the holes if the cap is on the bottle.)

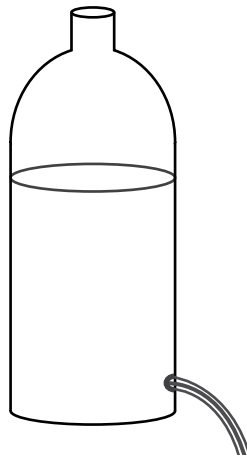

Figure 1

Timing and Length of Investigation

- ▶ **Teacher Preparation/Set-up:** 20–30 minutes

The prep time should be minimal for gathering equipment and materials needed. The holes can be put in 15 bottles with a soldering iron in well under 30 minutes.

- ▶ **Prelab:** 10–20 minutes

The prelab should also be minimal because it is assumed that students know in advance how to make and analyze graphs. You can engage students in a discussion of their intuition about the rate of drainage, techniques for timing, etc. With a little more investment in time and money, you can demonstrate the concept qualitatively using 4-inch diameter plastic landscaping drain tile, which comes with predrilled holes and can be set vertically on a tight-fitting cap. With minimal discussion following the demonstration, students may be better prepared to design their own investigation on a smaller scale with the “bottle” method described here.

▶ **Student Investigation:** 30–45 minutes

The experiment itself is likely to take less than 45 minutes allowing for practice runs and more than one attempt. Depending on the technology used (video analysis, calculators/computers, or pencil and paper), students’ analysis of results could take as little as 15 minutes or as much as 45 minutes. In any event, it is suggested this analysis work be completed outside of class.

▶ **Postlab Discussion:** 40–50 minutes

Postlab time should be provided to discuss techniques, results, and conclusions. For a class of 30 students, this could well extend for a full class period.

▶ **Total Time:** 1.5–2.5 hours

Safety

To avoid slippery floors or damage to equipment from water spills, it is a good idea to have a sponge and a mop available. (If access is available, the measurement phase of this lab could be moved outdoors.)

If it is decided that students are to use the soldering irons to make their own holes in the bottles, they need to be cautioned that the irons remain hot for some time after being turned off or unplugged. The hot irons should be removed to a safe area of the lab — perhaps creating “soldering stations” that have soldering iron holders for the hot irons as they cool.

Preparation and Prelab

Prior to this lab, students should have a basic understanding of fluids and fluid pressure, along with some introduction to fluid flow. Since the purpose of the experiment is for students to derive the relationship between fluid height in a container and the rate at which the fluid flows from the container, students need a conceptual understanding of conservation of energy and conservation of mass principles prior to the experiment, in order to make good decisions about experiment design.

However, students may not have actually done calculations with Bernoulli's equation. You might want to use demonstrations and assigned student reading to familiarize students with concepts. “Under Pressure” and “Fluid Pressure and Flow” are interactive simulations that help students develop an understanding of fluid pressure (see Supplemental Resources). The PhET website also has teacher-prepared student activities that can be used as homework or in class for formative assessment in preparation for the lab. Actual problem solving with the continuity equation and Bernoulli's equation, for example, would be appropriate follow-up assignments, once students discover the relationship in the lab.

The Investigation

The simple specific understanding for this experiment is that the rate at which liquids leave a container is a function of the square root of the distance of the surface above the hole. However, students should be told in advance only that they are to devise a procedure for gathering data that can be used to show the relationship between the two quantities — the rate at which fluid leaves the container and the height of fluid above the exit hole.

You can have materials ready, but allow students to discuss with each other in small groups how they will use those materials to setup the experiment. Encourage students — within your own comfort level — to devise their own ways to use the provided materials, or add materials if available.

The methods described below are for your benefit. Given a little time, students groups will come up with their own designs and will likely need little prodding to come up with similar methods.

Method I: Measuring depth vs. time

The most direct method students might choose to find the relationship between water depth above the exit hole and time would be to use a vertical piece of masking tape to make a marked scale on the outside of the discharge container. Then they could use a stopwatch to note regular time intervals and read the height at those even intervals in order to produce data regarding the height of the water as a function of time. If students choose this method, you might want to suggest that they mark the tape off in small increments to gather enough data points to make more accurate graphs. A watch or tablet app with a split time mode (or recording with a cell phone) makes this a much easier task. Graphs of this data could then be used to find the rate of change of depth over time.

Method II: Measuring depth vs. velocity

A second method (and perhaps an easier method for students to analyze) that students might choose is the “projectile method.” Students would again make a scale for the depth of the water, but this time they would allow the stream to fall a given height into a sink or large pan and record the horizontal distance traveled by the stream from where it leaves the hole to where it hits the pan for the different depths in the container.

Method III: Video analysis

If video equipment is available, (e.g., smartphone, tablet, or computer with a camera) a third data-gathering method that is a hybrid of video analysis with one of the previous approaches can be used effectively. This can be done in two distinctly different ways:

1. Students could simply make a video recording of the experiment described in either of the two methods above, so the data can be gathered from the recording; or
2. While being careful to use a correct perspective for the recording, students could use a video analysis program to directly do a graphical analysis. Using a video of the bottle as the water level falls and as the water exits the hole, students “track” the water as it exits and use distance and time to determine the speed of the water and also track the water level to determine the distance the water level falls in given time intervals. [NOTE: Some experience with video analysis is a good prerequisite for use of this method.]

Extension

It would be interesting for students to use the same apparatus and experimental methods to investigate how changing the density of the fluid changes the results. The easiest to use would be salt water, which has a larger density (that can be determined by students by measuring the mass of a small volume of the salt water and using the formula $\rho = m/V$). Other liquids, such as an alcohol/water mixture, which has a lower density, would also be fairly easy to use.

Assign students to groups to design plans that might be used to address questions related to water conservation. For example, one group could be assigned to design a plan to determine the amount of water that leaks from a dripping faucet in one day. Another group might be assigned to design a plan to find the volume of water used to irrigate a specific lawn, where students would have to designate lawn size and frequency of irrigation before making collection measurements and subsequent calculations.

Common Student Challenges

If students opt to study the height of the liquid in the container as a function of time, they might confuse the velocity of the surface (as it drops in height) with the velocity of the water as it exits the hole. The procedure of using the projectile motion method to obtain the exit speed avoids this confusion.

One form of reasoning that is ubiquitous in science, but that students have difficulty mastering, is to reason by using proportions without directly applying equations. That is, scientists often ask themselves, “If I double *this*, what happens to *that*?” If doubling *this* quadruples *that*, we can guess the form of the equation relating these quantities, and if doubling *this* increases *that* by 1.4, we can guess that equation as well. Moreover, we have some experience relating these relationships to what we might expect a graph to look like. This lab could be an ideal vehicle for encouraging this kind of reasoning.

“Identifying and Addressing Student Difficulties with Hydrostatic Pressure” describes student difficulties with pressure in a fluid and also has research questions that could be used for assessment (see Supplemental Resources).

If students are having difficulty deciding what to graph or how to setup graphs, provide a review. See “Special Focus: Graphical Analysis” in Supplemental Resources for worksheets.

Analyzing Results

Method I: Measuring height vs. time

There are several ways students could approach this analysis. Among these possibilities are:

1. Students could simply graph the data (height of water above the hole on y -axis and time on x -axis) and note that it looks like a section of a parabola. This indicates that a graph of height versus t^2 would yield a straight line. Calculating the slope of the best-fit line of this second graph will give them a mathematical relationship between h and t .

As a second step in the analysis, students should approximate the speed at which the liquid surface drops by calculating the change in height divided by time for small intervals of time, say 0.5 s, at several places over the range of data. They will find that the $\Delta h/\Delta t$, using short time intervals at different times after the experiment has started, will produce water speeds exiting the hole that decrease. This would then be plotted as v vs. t and should yield a linear graph and its corresponding equation. By eliminating t between the two equations, students can get an equation for the velocity of the surface as a function of time. As a challenge, students can use the speed at which the liquid surface drops to calculate the rate at which the volume in the container changes. They can then compare this to the volume of water exiting the hole, which can be calculated from the area of the hole and the speed at which the water is leaving the hole ($V/t = Av$). It will be clear that the exit velocity is proportional to the velocity at which the water surface drops or that the volume per second leaving the hole is equal to the volume per second change within the container.

- Students use a graphical analysis program on a computer or calculator to go from an h vs. t graph to a v vs. t graph. Of course such a technique is quicker and more elegant but might not provide the same degree of analytical understanding. In any case it should be noted that an attempt to use the continuity of flow equation (see Equation 3) to produce a match with Bernoulli's equation (see Equation 1) will fail because of losses in energy at the hole. Figure 2 provides a sample of the data and resulting graph made with a spreadsheet program:

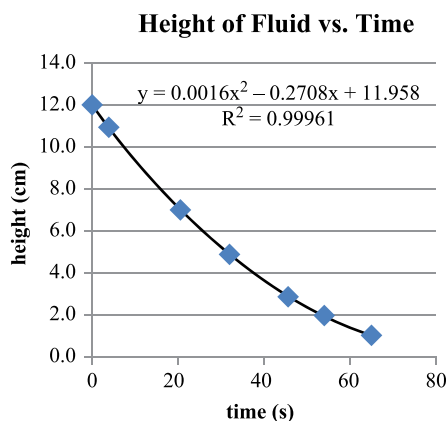

Figure 2

Method II: Measuring depth vs. velocity

Since the distance that the water falls is constant, the time of fall can be calculated and the horizontal velocity determined by the point of impact in the sink/pan. For this analysis, students should graph water depth and velocity. While this method gives a direct correlation of water depth and the square of the velocity, be aware that energy losses at the hole and air resistance will result in numbers for the speed that are smaller than those predicted by the ideal relationship of Bernoulli's equation.

Method III: Video analysis

Students who are familiar with video analysis techniques can use this method to gather the data necessary to either create their own graphs or, more likely, obtain graphs directly from the program used. According to which factors they chose to use in their analysis, they perform one of the analyses above.

Postlab

The results of this investigation should produce a mathematical model that indicates that the water flows from the container at a rate that is proportional to the square root of the distance of the water surface above the hole. The investigation provides an introduction to the relationship established by Bernoulli's law (see Equation 1).

Have students make predictions from their data by asking, "Based on factors you can describe but not control, do you expect your experimental calculations to be higher than or lower than the actual value?" You might have students use the continuity equation (see Equation 2) to compare the experimental results and those given by the theory. While the relation of v and y is confirmed by the experiment, the results for v will be found to be consistently smaller than the predicted values. Students should then be asked to suggest reasons for the systematic discrepancies.

Since this lab is a "discovery" of important mathematical relationships for fluids — the continuity equation and Bernoulli's equation — it is important that you allow students to share their results with other groups. Teacher guidance may be necessary to bring out exactly how data show these relationships if students have difficulty.

Bernoulli's law:

$$P + \rho gy + \frac{1}{2} \rho v^2 = \text{constant}$$

Equation 1

Continuity equation:

$$A_1 v_1 = A_2 v_2$$

Equation 2

During the wrap up you might ask the students how they think the size of the hole might relate to the actual speed of the water at the outlet. After they speculate on this, you could do a demonstration with a single bottle with two different size holes. After Bernoulli's law has been treated in class you might want to return to the observation of this discrepancy and ask the student to speculate on the reasons the energy of the water exiting the bottle is not as great as would be predicted from Bernoulli's law and the conservation of energy.

Another demonstration you might choose would be to attach a tube to the opening of the container and show that water projected vertically does not reach the height of the surface of the fluid. The losses due to friction and turbid flow are then evident.

Assessing Student Understanding

After completing this investigation, students should be able to:

- ▶ Design an experiment to collect data related to fluid flow rate;
- ▶ State that the speed at which liquids leave a container is a function of the square root of the distance of the surface above the hole;
- ▶ Relate experimental observations to continuity of fluid flow and to conservation of energy in fluid flow;
- ▶ Discuss and account for the fact that the mechanical energy of the fluid is not completely conserved;
- ▶ Compare his or her experimental results to the theoretical predictions and discuss why possible mechanical energy losses are incurred; and
- ▶ Discuss why the atmospheric pressure on the surface of the liquid in this experiment can be ignored.

Assessing the Science Practices

Science Practice 2.1 The student can *justify the selection of a mathematical routine* to solve problems.

Proficient	Selects a correct graphical method or correct set of mathematical routines that will correlate change in fluid height to rate of flow.
Nearly Proficient	Graphs data correctly or uses a mathematical routine that will correctly relate water level change to fluid flow, but does not find a way to correctly correlate them.
On the Path to Proficiency	Graphs the data for the experiment, but does not make correct correlations to water flow.
An Attempt	Makes an attempt to calculate rate of fluid flow, but does not select an appropriate graphical or mathematical method to process data.

Science Practice 2.2 The student can *apply mathematical routines* to quantities that describe natural phenomena.

Proficient	Uses either a graph or set of mathematical routines to correctly determine the square root relationship between rate of flow and change in water level height.
Nearly Proficient	Uses graphical methods correctly or uses the correct mathematical routines to calculate fluid flow and water level height changes, but makes an error in calculation.
On the Path to Proficiency	Correctly calculates rate of flow from the hole and change in water height but does not connect them; or, graphs the data correctly but does not use the graph to make necessary correlations.
An Attempt	Makes an attempt to calculate water velocity, but does not reach conclusions as required by the experiment.

Science Practice 4.3 The student can *collect data* to answer a particular scientific question.

Proficient	Records all relevant data, with units, in a complete and well-organized way.
Nearly Proficient	Records all data in a complete and well-organized way, but misses a key element that can be corrected, such as failing to put units on some measurement.
On the Path to Proficiency	Gathers data in an organized way, but misses some crucial information that will be needed for calculations.
An Attempt	Gathers data but does not record it in a well-organized manner.

Science Practice 6.2 The student can *construct explanations of phenomena based on evidence* produced through scientific practices.

Proficient	Presents a thorough and insightful written analysis of the experiment, with experimental observations clearly connected to the concepts of fluid mass and energy conservation concepts.
Nearly Proficient	Presents a well-prepared written analysis of experimental results but with a key element missing, such as relating the final calculations to conservation of energy for fluids.
On the Path to Proficiency	Explains observations and experimental results in an analysis, but the analysis is incomplete.
An Attempt	Makes an attempt at a verbal explanation in the analysis of the experiment, but the analysis may be disconnected or incomplete.

Science Practice 7.1 The student can *connect phenomena and models* across spatial and temporal scales.

Proficient	Describes a clear, complete connection between how water droplets behave like small projectiles on a micro scale to how a stream of water behaves on a macro scale.
Nearly Proficient	Makes a strong start making connections on a micro and macro scale for fluid flow, but the explanation has missing elements.
On the Path to Proficiency	Makes some connections but does not clearly explain; for example, points out that water flow can be compared to what was learned about projectile motion, but does not explain how single drops are like projectiles.
An Attempt	Makes an attempt to find connections between the experiments on fluid flow, but the connections are not explained.

Supplemental Resources

“Coefficient of Discharge.” Denver University. Accessed September 1, 2014. <http://mysite.du.edu/~jcalvert/tech/fluids/orifice.htm>. [*This website distills the basic treatment of fluid flow through small orifices.*]

“Draining Tank Example.” eFunda. Accessed September 1, 2014. http://www.efunda.com/formulae/fluids/draining_tank.cfm#calc. [*This website provides an interactive calculator for the flow from a container. It might be of interest to students who want to compare their results with result of the mathematical model based on Bernoulli’s Law, but it should be noted this calculator treats the ideal case and assumes no energy losses.*]

“Fluid Pressure and Flow.” PhET. University of Colorado Boulder. Accessed September 1, 2014. <https://phet.colorado.edu/en/simulation/fluid-pressure-and-flow>.

Loverude, Michael E., Paula R. L. Heron, and Christian H. Kautz. “Identifying and Addressing Student Difficulties with Hydrostatic Pressure.” *American Journal of Physics* 78, no. 1 (2010): 75–85.

McDermott, Lillian C., Peter S. Shaffer, and the Physics Education Group at the University of Washington. “Pressure in a Liquid.” In *Tutorials in Introductory Physics*. Upper Saddle River, NJ: Pearson, 2012. [*Contains a guided inquiry tutorial based on Michael Loverude’s Ph.D. dissertation that addresses student difficulties with topics of this lab.*]

“Special Focus: Graphical Analysis.” AP Physics 2006–2007 Professional Development Workshop Materials. College Board. Accessed September 1, 2014. http://apcentral.collegeboard.com/apc/public/repository/AP_Physics_Graphical_Analysis.pdf.

“Teacher Professional Development Resources.” Seattle Pacific University. Accessed September 1, 2014. <http://www.spu.edu/depts/physics/tcp/tadevelopment.asp>. [*The Open Source Tutorials project has a modifiable tutorial on pressure.*]

“Under Pressure.” PhET. University of Colorado Boulder. Accessed September 1, 2014. <https://phet.colorado.edu/en/simulation/under-pressure>. [*This simulation allows students to see how pressure changes as they change fluids, gravity, container shapes, and volume.*]

This page is intentionally left blank.

AP Physics 2 Investigation 3:

RC Circuits

How do the resistors and capacitors in an RC circuit affect the behavior of the circuit?

Central Challenge

In this lab, students perform a series of investigations of RC circuits in order to observe and analyze the relationships that exist when resistors, capacitors, and emf sources are arranged in different ways (series, parallel, or combinations). Students will be building on their prior knowledge of simple, DC circuits from AP Physics 1 (or a similar introductory course) and will now gain an understanding of how to predict the current through a resistor or the charge on a capacitor, and the potential difference across resistors and capacitors under steady-state conditions.

Background

When a capacitor and a single resistor are connected in a simple series circuit with a battery or power supply, there is a transient behavior as the capacitor is filling with charge. The current initially flows freely onto the capacitor, but as the capacitor fills, the rate of flow of charge onto the capacitor (i.e., the current in the circuit) decreases eventually to zero. The capacitor then is as full of charge as the battery can make it; the potential difference across the capacitor being equal to the potential difference across the battery. There is at that point no potential difference across the resistor, and there is no flow of charge through the resistor. When the wires are disconnected from the battery and connected to each other, the capacitor discharges through the resistor until there is no more excess charge stored on the capacitor plates. This transient current can be visualized by charging and discharging a capacitor through small light bulbs, provided the capacitance is large enough for the charging to take a few seconds or more.

When several resistors are connected in a circuit with a capacitor, the transient behavior is more complicated. Initially the capacitor is empty, and all charge flows easily in the branch containing the capacitor. The capacitor momentarily acts as a short circuit to any elements with which it is connected in parallel. However, when the capacitor is full, no more charge can flow in that branch, and the capacitor acts like an open circuit in that branch of the circuit. Depending on how the circuit is constructed, current can still flow in branches that are parallel to the branch containing the capacitor.

The charge on the capacitor can be determined by the equation $Q = C\Delta V$, where Q is the magnitude of excess charge on each plate of the capacitor (in coulombs), C is the capacitance (in farads), and ΔV is the potential difference across the capacitor (in volts). The resistor in the charging circuit only affects the time it takes the capacitor to charge to the final value Q . It does not affect that final value.

Real-World Application

As students learned in their first physics course, many of their daily activities depend on the use of electric current in complex circuits. The timing effect of the RC circuit is at play in some charging processes in commercial electronics. In particular, RC circuits are used in camera-flash units. One circuit allows the capacitor to charge slowly, and a separate circuit allows the capacitor to discharge very rapidly through a flash bulb. The idea of capacitance changing by changing the geometry or dielectric is also used in some commercial applications (some computer keyboards and accelerometers are examples of this usage). Touch screens on students' phones and tablets use capacitive elements to determine where the user is touching the screen. Students could investigate how this works as one extension of this lab (though not a lab activity itself).

Defibrillators monitor heart rhythm and use the charge on a capacitor to deliver a large amount of energy to restore normal rhythm in the case of a very fast, abnormal heartbeat. Automatic external defibrillators (AEDs) are common in public buildings for use by people without training, since the AED will not deliver a shock if the heart is in normal heartbeat rhythm. Such capacitors vary but may range from 100–200 microfarads at 2–3 kilovolts to deliver the necessary energy.

Inquiry Overview

There are three parts to this investigation, all of which involve guided inquiry, in which students are given a question to answer. Students then design an investigation to answer each question. It is not the intention in this lab for students to develop graphs showing the exponential trends or to actually make final calculations in each situation; rather they are to develop design plans that allow meter measurements to support observations, leading to relationships rather than calculated answers.

In Part I, students investigate how connecting capacitors in series and parallel affects the total capacitance of the circuit. In Part II, they investigate how a resistor connected in series with a single capacitor affects the total charge on a capacitor after it is fully charged by a battery. In Part III, they investigate how the potential differences across the various elements of an RC circuit change as the capacitor charges.

Connections to the AP Physics 2 Curriculum Framework

Big Idea 4 Interactions between systems can result in changes in those systems.

Enduring Understanding	Learning Objectives
4E The electric and magnetic properties of a system can change in response to the presence of, or the changes in, other objects or systems.	4.E.5.1 The student is able to make and justify a quantitative prediction of the effect of a change in values or arrangements of one or two circuit elements on the currents and the potential differences in a circuit containing a small number of sources of emf, resistors, capacitors, and switches in series and/or parallel. (Science Practices 2.2 and 6.4)
	4.E.5.2 The student is able to make and justify a qualitative prediction of the effect of a change in values or arrangements of one or two circuit elements on currents and potential differences in a circuit containing a small number of sources of emf, resistors, capacitors, and switches in series or parallel. (Science Practices 6.1 and 6.4)
	4.E.5.3 The student is able to plan data collection strategies and perform data analysis to examine the values of currents and potential differences in an electric circuit that is modified by changing or rearranging circuit elements, including sources of emf, resistors, and capacitors. (Science Practices 2.2, 4.2, and 5.1)

Big Idea 5 Changes that occur as a result of interactions are constrained by conservation laws.

Enduring Understanding	Learning Objectives
5B The energy of a system is conserved.	5.B.9.5 The student is able to use conservation of energy principles (Kirchhoff's loop rule) to describe and make predictions regarding electrical potential difference, charge, and current in steady-state circuits composed of various combinations of resistors and capacitors. (Science Practice 6.4)
	5.C.3.6 The student is able to determine missing values and direction of electric current in branches of a circuit with both resistors and capacitors from values and directions of current in other branches of the circuit through appropriate selection of nodes and application of the junction rule. (Science Practices 1.4 and 2.2)

[NOTE: In addition to those listed in the learning objectives above, Science Practice 4.3 is also addressed in this investigation.]

Skills and Practices Taught/Emphasized in This Investigation

Science Practices	Activities
1.4 The student can <i>use representations and models</i> to analyze situations or solve problems qualitatively and quantitatively.	Students draw circuit diagrams and label the potential differences for different configurations.
2.2 The student can <i>apply mathematical routines</i> to quantities that describe natural phenomena.	Students apply Kirchhoff's loop rule to compare the potential differences across the various elements of the RC circuit.
4.2 The student can <i>design a plan</i> for collecting data to answer a particular scientific question.	Students make decisions about how to connect resistors and capacitors in series and parallel and how best to gather, record, and analyze data.
4.3 The student can <i>collect data</i> to answer a particular scientific question.	Students collect and record data from qualitative observations of bulb lighting and from direct measurements of potential difference using a voltmeter.
5.1 The student can <i>analyze data</i> to identify patterns or relationships.	Students use potential difference and current measurements to analyze how the circuit connections affect the behaviors of resistors and capacitors in the circuit. Students assess the uncertainties in their measurements to help inform the analysis of their data and support their conclusions.
6.1 The student can <i>justify claims with evidence</i> .	Students draw conclusions based on their measurements of potential differences and justify those conclusions using their measurements.
6.4 The student can <i>make claims and predictions about natural phenomena</i> based on scientific theories and models.	Students make predictions about bulb lighting and potential differences in circuits in order to help inform further circuit designs they will create and observe.

[NOTE: Students should be keeping artifacts (lab notebook, portfolio, etc.) that may be used as evidence when trying to get lab credit at some institutions.]

Equipment and Materials

Per lab group (three to four students):

- ▶ **Part I:**
- ▶ Three D-cell batteries and battery holder or DC power supply
- ▶ 8–10 connecting wires
- ▶ Four miniature screw lamps (size #40 or #50, with holders)

- ▶ At least two nonpolar 100,000 (or 25,000) microfarad capacitors (These capacitors are expensive, but this type of investigation can only be done with a long “time constant,” so these are your best choice if you are using the bulb as a visual timer. The nonpolar capacitors are easier for students to work with and less likely to be damaged than the polar capacitors.)

▶ **Part II:**

In addition to the equipment from part I, this part requires:

- ▶ Several resistors in the 10–50 ohm range rated at least 1 watt or a resistor decade box with variable resistance
- ▶ Stopwatch

▶ **Part III:**

In addition to the equipment from Parts I and II, this part requires:

- ▶ Voltmeter or multimeter
- ▶ Several resistors in the 200–500 ohm range rated at least $\frac{1}{2}$ watt, or a resistor decade box with variable resistance
- ▶ Single pole switch

Extension

In addition to the equipment from Parts I–III, this part requires:

- ▶ Ammeter or multimeter

[**NOTE:** If you are not using the bulb as a visual timer, then you can opt for more traditional resistors and more traditional capacitor values (e.g., 1000–4700 microfarads, which are very inexpensive) from electronic supply stores, but you will probably sacrifice a little in student understanding. If you are using resistors and capacitors, try to keep your time constant ($\tau = RC$) for each pair of R and C to values between 1–5 seconds. This will ensure that the relevant physics can be measured or observed by students. An example of this would be a resistor value of $R = 10,000$ ohms and capacitor value of $C = 200$ microfarads; this would give a time constant of $RC = 2.0$ seconds. A general rule of thumb is that the charging time for a capacitor is approximately five time constants. (i.e., total charging time equal to about $5RC$.)]

Timing and Length of Investigation

- ▶ **Teacher Preparation/Set-up:** 15–20 minutes

This time is to gather materials, if everything has already been purchased.

- ▶ **Prelab:** 60 minutes

A suggested prelab activity is a tutorial/lab activity of investigating the capacitors' geometrical/physical properties and the effect of those properties on capacitance. "Capacitor Lab" is one suggested tutorial (see Supplemental Resources). Students should also be given time in small groups prior to the lab to design their procedure and setup, as well as to discuss assumptions and other factors that may affect the lab measurements and observations.

▶ **Student Investigation:** 120 minutes

The time for students will vary greatly depending on what issues occur during the students' exploration time. Give students enough time to explore and make mistakes as they try to reconcile their ideas about the behavior of capacitors in these circuits. Many students are fascinated by the actual charging behavior of the RC circuit. That behavior usually challenges their naïve notions about how the capacitor will behave in the circuit, and this conflict in their minds usually leads to discovery and understanding if they are given the chance and enough time to formulate the proper physical reasoning for themselves.

▶ **Postlab Discussion:** 45 minutes

Allow enough time for your class to have a vigorous student-led discussion about what they observed in the laboratory investigations. Give enough time for students to have some back and forth questioning about evidence and behavior. You can also provide some driving questions to the discussion that include students' analysis of sources of uncertainty in measurements and how uncertainties may have affected final results.

▶ **Total Time:** approximately 4 hours

Safety

There are no specific safety concerns for this lab, as long as students do not have access to large sources of potential difference. The 25,000- and 100,000-microfarad capacitors can be charged to a potential difference of 25 volts and 10 volts respectively, and then it can cause harm if a student makes contact with both poles. With only three D-cell batteries it poses little danger to students. Advise students to always handle capacitors carefully, as they can hold charge for a long time. In addition, all general lab safety guidelines should always be observed.

Preparation and Prelab

Circuits do not lend themselves to open inquiry in the same way that topics in mechanics do. Provide students with some guidance on connecting circuits and using meters to prevent them from damaging the equipment, wasting time on fruitless observations or circuits that don't work, and harming themselves. The amount of preparation and prelab required depends on students' prior experience with circuits involving bulbs and capacitors.

Students should have experience charging and discharging capacitors through bulbs using the equipment. The first few sections of the CASTLE™ curriculum, which pertain more to AP Physics 1, are worth having students do, if they have not done it in a prior course. They should have seen that the bulbs light up for a longer period of time when charging a larger capacitor. They should also have seen a capacitor charged with a three-battery pack, and then charged more by adding another three-battery pack in the circuit in series. When the capacitor is eventually discharged, the brighter bulb lighting and longer time of bulb lighting (the time constant is the same but the length of time there is sufficient current to observe a lit bulb is longer) is indicative of the fact that more charge has been stored on the capacitor when the second battery pack was added. They can use the time of bulb lighting during capacitor discharging as an indicator of the amount of charge stored on the battery pack, so long as each time they discharge through the same bulbs. One of the sections of the CASTLE curriculum outlines this process for students, but in this type of inquiry, in a second-year course, students should be allowed to discover this for themselves (see “Using Models to Teach Electricity — the CASTLE Project” or the PASCO site in Supplemental Resources).

Students also must be familiar with the use of a voltmeter in a circuit. Hopefully, prior labs, either in AP Physics 1 or AP Physics 2, have provided them with this experience. If not, you must demonstrate the proper use of voltmeters in circuits.

Circuits labs are very teacher-intensive labs and students require lots of supervision and direction. This is exacerbated by the addition of capacitors to the circuits and the necessity of reaching the steady-state condition to make observations. Be patient with students and give them proper time and assistance to make these observations.

The Investigation

Part I: Capacitors in Series and Parallel

The purpose of this part of the activity is to have students investigate the charge accumulated on capacitors connected in series and in parallel. Present students with two large (100,000-microfarad or 25,000-microfarad) nonpolar capacitors, a battery pack, connecting wires, and #40 bulbs with sockets. Ask the students to design an experiment to see how combining the capacitors (in series and in parallel) affects the total capacitance. You can further refine the question by asking them to determine if adding capacitors in parallel or series increases the total capacitance, or charge storing capability, of the system of capacitors. Students may need some direction to come up with an appropriate plan. One method they can use is to observe the charging time for various capacitor combinations. They should then be able to reason that longer charging times implies more charge on the capacitor. And more charge on the capacitor implies a larger capacitor (if the battery used to charge the capacitor is constant).

Part II: Resistors in RC Circuits

The purpose of the second part of the experiment is to determine if the resistor affects the amount of charge on a capacitor in a circuit, and if so, how does it affect it? In other words, will a larger resistor allow more charge onto the capacitor, less charge onto the capacitor, or the same charge onto a capacitor as a smaller resistor does? Give students various resistors to use in a charging circuit. The range of resistances should complement the size of the capacitors such that the charging time is less than 10–60 seconds or so. With a 100,000-microfarad capacitor, the range should be between 5–100 ohms. For a different capacitor, set the time constant to about $1/5$ of the total time you want the charging to take and use the equation $\tau = RC$ to calculate an appropriate resistance range. Give students at least four to five different resistors to choose from. If only two different resistance values are available, then they combine them in series and parallel to get different resistances. For example, two 10-ohm resistors in series create a 20-ohm resistor, and in parallel they create a 5-ohm resistor. This exercise can provide a good review for calculating equivalent resistances.

Students then should discharge the capacitor in each case through the same light bulb(s). A #40 or #50 bulb works well. They should decide how to use lighting and dimming of the light bulbs during discharging to determine if the capacitors have been charged to the same amount or different amounts with different resistors. For example, students charge the capacitor using a 20-ohm resistor. Then they discharge it through lightbulbs and observe the lighting time. Then they charge the capacitor using the 100-ohm resistor, and again discharge it through the same bulbs. Longer bulb lighting time would indicate more charge had been stored on the capacitor. Depending on the level of your students, you may want to engage the whole class in a brainstorming session about this before you break them into groups, or you may want to work individually with each group as needed.

It is unlikely that a bulb in series with a resistor and capacitor will light up significantly, so they cannot use the bulb lighting to determine if the capacitor is fully charged or not. So students should be instructed to connect the circuit and wait an appropriate amount of time to make sure the capacitor is fully charged. This may be 15–30 seconds, or up to a full minute, depending on the time constant of the circuit. A rule of thumb is that a capacitor is “fully” charged in about five time constants (or $t = 5RC$). To avoid a potential misconception, students should allow each combination to charge for the same amount of time, so set the suggested time as that for the largest RC combination value.

If students are having a difficult time making observations with the bulbs lighting, they could use an ammeter to make observations of the current. Some students have found this more effective and, no pun intended, enlightening.

Part III: Potential Difference in an RC Circuit

In this part of the lab, students investigate how the potential differences change across the various circuit elements as a capacitor charges. Give them a voltmeter and a switch in addition to the capacitors, batteries, and wires from the previous parts. Ask them to create several circuits, each of which contains a battery, a switch, at least one resistor, and a capacitor (see Figure 1). They should use the voltmeter to observe the potential differences across the capacitor and resistor. For this experiment, you want the charging time to be roughly 30 seconds, so with a capacitance of 25,000 microfarads, resistances of 200–500 ohms are appropriate. Students should observe the potential differences across the resistor, across the capacitor, and across the battery from when the switch is closed until no more changes are observed in the voltmeter reading. They should be encouraged to see how the potential differences change if the single resistor in the circuit is in series with the capacitor or if it is in parallel with the capacitor.

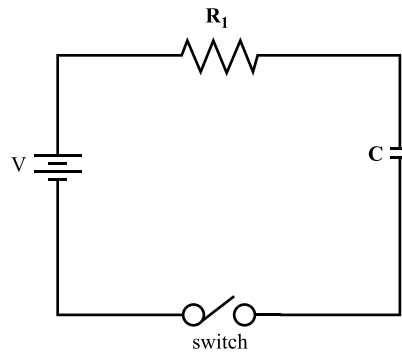

Figure 1

Encourage students to put more than one resistor in the circuit. For example, they could observe the potential difference changes across the various circuit elements in the circuit in Figure 2 below. Depending on how much time you have for this investigation, you can have students observe three or four such circuits.

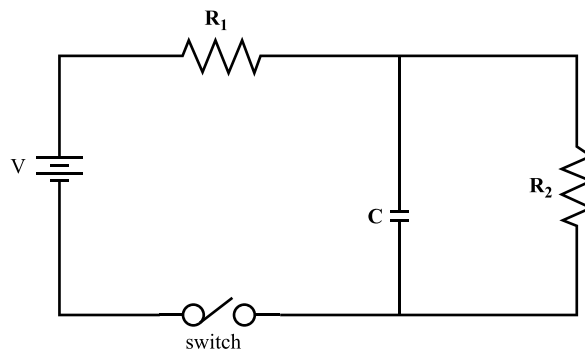

Figure 2

Extension

If additional time is available, or an additional challenge is desired, students could use an ammeter to investigate the initial and steady-state currents in RC circuits (especially those with more than one resistor, such as in Figure 2 above). A careful tutorial is required on the proper use of ammeters. Students have a tendency to use them like voltmeters, connecting them in parallel and immediately blowing a fuse. Have plenty of spare fuses on hand. This is particularly prevalent when multimeters are used both as ammeters and voltmeters.

Common Student Challenges

Capacitor behavior (in series with other capacitors and in series with a resistance) has always been a difficult concept for physics students. You can help students work through common misconceptions (e.g., no current “through” a capacitor or “more capacitors means more capacitance”) by making sure they stick to the rules and models that have been developed in this course (e.g., Kirchhoff’s loop rule and Kirchhoff’s junction rule). The advanced ideas (capacitors in an alternate branch of the circuit) can be better managed by you and better understood by students if the fundamental charging behavior of a capacitor is fully understood. The exponential decay relationship of charge and current in a capacitor can be avoided and replaced with the total time to charge, which represents the total value of the capacitance in the system when the resistance is held constant (i.e., one capacitor in series with a resistor will take a certain time to charge, but two identical capacitors in series with each other and with the same resistor will have half the total capacitance, so the charging time should be less).

Be ready for the endless stream of questions that will arise during the execution of an open-ended lab investigation such as this one. Students will want to know if the circuit they have created is correct. You can have them explain how they connected it and point out any flaws in their reasoning. They will want to know if they are getting accurate results. Encourage them to double check their measurements. You can ask them to explain why they think their measurements may be incorrect. Depending on their answers, guide their reasoning with more questions. The Socratic method works best — constantly asking students questions that require the reasoning behind their choices — but it also requires you to think quickly and respond to unanticipated questions. Be prepared for improper use of meters to show up at some point, which will cause false or misleading results. Also, be prepared for some bulbs or capacitors to show some nonuniformity during these investigations. The bulbs (depending on the manufacturer) can vary in resistance/brightness. The bulbs also are non-ohmic. Keep this in mind in case some small measuring issues show up at some lab stations.

This lab will surely challenge your students. Be prepared for them to make mistakes and to meet those mistakes with good questions and discussion that yield critical thinking. You should operate from the standpoint that if students take their time and make careful and deliberate measurements and make decent observations, then they will discover the fundamental nature of the capacitor's behavior in these RC circuits.

Analyzing Results

It is left to your discretion as to whether you want to stop after each part of the lab and discuss that part individually with the class, or wait until all students complete all three parts. Alternatively, you could assess each group individually to make sure they have gained the proper understanding before continuing. The following should be part of the discussion of each part.

Part I:

Each group will put their results on a large piece of butcher paper or on a large whiteboard. Ask students to answer the following guiding questions:

- ▶ What procedure was followed?
- ▶ How was the circuit setup?
- ▶ What measurements/observations were taken?
- ▶ What was observed?
- ▶ What conclusions can be drawn from these observations?

Students should start by sharing their findings with the class. They should have created a circuit with at least one bulb in series with the capacitor or capacitors. They can then use the bulb lighting time and brightness as a measure of how much charge had flowed onto the capacitor. They should conclude that the longer lighting time implies more charge had flowed onto the capacitor. They should have observed that when two capacitors are connected in series, the lighting time is shorter, and when two bulbs are connected in parallel, the lighting time is longer. Thus, the parallel arrangement holds more charge and thus has a greater capacitance. If a 100,000-microfarad capacitor is charged using a three D-cell battery pack, through a #40 bulb, the bulb will be lit (indicating charging time) for roughly 4 seconds. When two capacitors are in parallel, the charging time will approximately double. When the two capacitors are in series, the charging time will decrease by a factor of two, indicating that two capacitors in series act as a smaller capacitor.

Part II:

If students grasp the concept from Part I that the bulb lighting is a sign of how much charge is on a capacitor, then they should be able to use that to gauge the amount of charge on the capacitor. If they have not grasped that yet, they should be shown demonstrations to help them come to this understanding before they continue. Again, have the students answer the following guiding questions in their sharing with the class:

- ▶ What procedure was followed to determine the effect of resistance on total capacitor charge?

- ▶ What was observed?
- ▶ What conclusions can be drawn from these observations?

They should have charged the capacitor with different resistors, and discharged the capacitor always through the same set of bulbs. They should have observed that the discharging behavior is the same for all of the resistors implying that the size of the resistor used for charging does not affect the charge on the capacitor. When a 100,000-microfarad capacitor is charged using a three D-cell battery pack, it should discharge through a #40 bulb, lighting the bulb for approximately 4 seconds. This should be independent of which resistor or combination of resistors was used to charge it.

Part III:

Ask students to summarize their observations and any patterns they observed to share with the class in a whole-class discussion. Have them consider the following questions:

- ▶ How does the potential across the capacitor change during charging? During discharging?
- ▶ How does the potential difference across the resistor change during charging? During discharging?
- ▶ Compare the potential differences across the capacitor and resistor during charging. What do you notice?
- ▶ Compare the potential differences across the capacitor and resistor during charging to the battery potential difference. What do you notice?

What students report from this part of the lab will vary from group to group. Lead them to focus on the potential difference just after the switch is closed and a long time after the switch is closed (i.e., the steady state). Once each group has shared its results, you can lead the group to focus on patterns that they see in the data. How much leading they need will depend on the group of students in the room. Some may immediately notice that the resistor has a large potential difference initially, and then at the end has a zero potential difference (in the simple circuit). You may then lead them to look at the capacitor's potential difference at these times in light of Kirchhoff's loop rule (i.e., the rule for potential differences in series).

Assessing Student Understanding

After completing this investigation, students should be able to:

- ▶ Cite evidence that the system of identical capacitors in parallel has more capacitance than a single identical capacitor;
- ▶ Cite evidence that the system of identical capacitors in series has less capacitance than a single identical capacitor;
- ▶ Cite evidence that the resistor in a simple RC circuit does not control how much charge is on a fully charged capacitor (there is a dependence when a resistor is placed in series with a resistor and capacitor in parallel);

- ▶ Demonstrate an understanding of the potential difference across a resistor in a simple RC circuit is equal to the battery potential difference initially and finally it is zero; and
- ▶ Demonstrate an understanding that the potential difference across a charging capacitor in a simple RC circuit is initially zero but equal to the battery potential difference in the steady state.

Assessing the Science Practices

Science Practice 1.4 The student can *use representations and models* to analyze situations or solve problems qualitatively and quantitatively.

Proficient	Connects a circuit according to a circuit diagram containing a capacitor and one or more resistors in series and/or parallel. Draws a circuit diagram when presented with a physical circuit consisting of batteries, capacitors, wires, and bulbs or resistors.
Nearly Proficient	Connects a simple series circuit containing a resistor and a capacitor and a battery based on circuit diagram. Draws an accurate circuit diagram for a circuit containing a resistor and a capacitor in series.
On the Path to Proficiency	Requires significant assistance in drawing an accurate circuit diagram.
An Attempt	Identifies a battery, bulb, resistor, and capacitor in a circuit diagram.

Science Practice 2.2 The student can *apply mathematical routines* to quantities that describe natural phenomena.

Proficient	Applies Kirchhoff's loop rule appropriately to multiloop circuits containing resistors and capacitors.
Nearly Proficient	Applies Kirchhoff's loop rule to a single circuit loop with a resistor and a capacitor.
On the Path to Proficiency	Requires significant assistance in applying Kirchhoff's loop rule to a simple circuit.
An Attempt	Identifies objects in a single loop, but does not accurately identify their potential differences to apply Kirchhoff's loop rule.

Science Practice 4.2 The student can *design a plan* for collecting data to answer a particular scientific question.

Proficient	Designs a valid plan for determining how capacitance is affected by adding capacitors in series and parallel. Designs an effective plan for determining how the resistance in circuit affects the charge stored on a capacitor.
Nearly Proficient	Designs a mostly complete plan but fails to account for one factor.
On the Path to Proficiency	Requires significant assistance in designing a plan, designs a plan with major flaws, or fails to account for multiple factors.
An Attempt	Designs a plan that is not valid for answering the questions posed in the inquiry.

Science Practice 4.3 The student can *collect data* to answer a particular scientific question.

Proficient	Makes accurate observations of bulb lighting and voltage measurements around a circuit containing bulbs and/or resistors, capacitors, and a battery.
Nearly Proficient	Makes mostly accurate measurements with a minor flaw or mistake in observation or measurement.
On the Path to Proficiency	Makes measurement mistakes or inaccurate observations of bulb lighting.
An Attempt	Makes major measurement mistakes or largely inaccurate observations of bulb lighting.

Science Practice 5.1 The student can *analyze data* to identify patterns or relationships.

Proficient	Correctly identifies patterns of bulb lighting to determine the effect of the resistance in a circuit on the charge stored in a capacitor.
Nearly Proficient	Uses the result but cannot articulate why bulb lighting time is related to the total charge on the capacitor.
On the Path to Proficiency	Cannot demonstrate that bulb lighting time is indicative of charge stored on the capacitor.
An Attempt	Unable to correctly discharge the capacitor through the same bulbs each time.

Science Practice 6.1 The student can *justify claims with evidence*.

Proficient	Justifies the claim that two capacitors in parallel have a greater capacitance than one alone with accurate reference to observations made in the lab. Justifies that capacitors in series have less capacitance than a single capacitor alone.
Nearly Proficient	Makes correct observations, but needs significant assistance in justifying the relationships between capacitors in series and parallel.
On the Path to Proficiency	Demonstrates that bulb lighting is related to total capacitance, but cannot accurately articulate the relationship or use it to justify a claim.
An Attempt	Unable to support a claim with evidence; instead merely restates the claim in different words as justification.

Science Practice 6.4 The student can *make claims and predictions about natural phenomena* based on scientific theories and models.

Proficient	Predicts the potential differences around the circuit based on Kirchhoff's loop rule, relating a zero sum of potential difference to conservation of energy.
Nearly Proficient	Predicts the potential differences around the circuit based on Kirchhoff's loop rule without being able to thoroughly articulate the basis for the rule.
On the Path to Proficiency	Makes minor errors in claims about the potential difference around a loop.
An Attempt	Requires extensive assistance in making claims about potential differences around a loop using Kirchhoff's loop rule.

Supplemental Resources

"Capacitor Lab." PhET. University of Colorado Boulder. Accessed September 1, 2014. <http://phet.colorado.edu/en/simulation/capacitor-lab>. [*Provides an excellent simulation with plenty of teacher resources attached. It does an excellent job of simulating visually a few properties of the capacitor (charging, geometrical changes, and energy storage). Students can measure capacitance (with meters on tutorial) and then plot capacitance vs. area. The effect of the dielectric constant on capacitance can also be explored in a similar way.*]

"CASTLE Kit." PASCO. Accessed September 1, 2014. http://www.pasco.com/prodCatalog/EM/EM-8624_castle-kit/.

Chabay, Ruth, and Bruce Sherwood. *Electric & Magnetic Interactions*. 3rd ed. Hoboken, NJ: John Wiley & Sons, Inc., 2007. [*An excellent resource for topics in Electricity and Magnetism. There is plenty in this textbook to help a physics teacher supplement his or her course.*]

“Curriculum Resources.” Arizona State University. Accessed September 1, 2014. <http://modeling.asu.edu/Curriculum.html>.

McDermott, Lillian C., Peter S. Shaffer, and the Physics Education Group at the University of Washington. *Tutorials in Introductory Physics*. Upper Saddle River, NJ: Pearson, 2012. [An outstanding supplementary resource for activities and teaching approaches for electrostatics and circuits topics. Many of the tutorials are completely in the “inquiry” mode.]

Rosenthal, Alvin S., and Charles Henderson. “Teaching about Circuits at the Introductory Level: An Emphasis on Potential Difference.” *American Journal of Physics* 74, no. 4 (2006): 324–328. [This paper reinforces the idea that using the idea of “potential difference” or the voltmeter reading is a much better approach to teach circuit ideas to introductory students. The authors believe this approach discourages the memorization of combination rules and Kirchhoff’s rules and gives the student a better footing of the fundamental concepts involving capacitors in circuits that have always challenged physics students.]

Steinberg, Melvin S., and Camille L. Wainright. “Using Models to Teach Electricity — the CASTLE Project.” *The Physics Teacher* 31, no. 6 (1993): 353–357. [This paper provides an introduction to the CASTLE curriculum.]

Young, Douglas. “Exploring Series and Parallel Combinations of Capacitors by Inquiry.” *The Physics Teacher* 44, no. 6 (2006): 366–368. [This paper gives some details of the general approach outlined in this investigation. It is a good read for teachers who have not had much exposure to capacitors in circuits. The paper also points out many of the details a teacher will need to obtain and use the proper electronic materials for their classroom.]

AP Physics 2 Investigation 4: Magnetism

How can we investigate magnetic fields?

Central Challenge

This investigation encourages students to explore the magnitude and direction of the magnetic field of magnets, current-carrying wires, and Earth, both qualitatively and quantitatively, using magnets, compasses, iron filings, and (optional) magnetic field probes.

Background

This investigation can be used to either generate or enhance students' knowledge of a vector or field-line representation of the magnetic field based on qualitative measurements. Once the vector nature of the field has been explored qualitatively, students can make quantitative measurements of the magnitude of the magnetic field. The investigation also explores the concept of superposition, as applied to the magnetic field. While there is not significant numerical analysis, vector fields is an area of quantitative difficulty for students, and this will help in developing semiquantitative representations.

Representations of these fields are important to the skills that students need to develop in the course. This activity develops the pattern of magnetic field vectors tangent to concentric circles around a current-carrying wire; the dipole pattern of field vectors around a bar magnet are needed representations. It also helps develop the needed representations of magnetic materials as containing magnetic domains that are themselves little magnets.

Real-World Application

Magnets are used in many real-life applications, such as burglar alarms, doorbells, loudspeakers, and electromagnetic motors and generators. Since the invention of the compass, the Earth's magnetic field has long been used for navigation and finding direction (even birds and magnetotactic bacteria use Earth's magnetic field to navigate or orient themselves). Archeomagnetic dating is also used to study the past history of the earth's magnetic field. Other applications include MAGLEV, or magnetically levitated trains, and MRI machines. Investigations into magnetic fields will help connect students to these real-life applications.

Inquiry Overview

This guided-inquiry based investigation allows students to explore the magnetic fields all around us, such as that of Earth, and the fields of permanent magnets and current-carrying wires. With proper guidance, this investigation can be implemented before students study magnetism in class. However, the investigation is also quite useful after the concept and vector nature of magnetic fields (along with some mathematical representations) have been introduced, in order to give a laboratory experience with qualitative observations and the design of procedures for measuring a magnetic field. The investigation also enhances the understanding of superposition of fields.

Part I is a qualitative investigation of magnetic fields. [NOTE: This can take between 50 and 70 minutes of instructional time if it is used as a basic introduction, as students explore new concepts. If this is a first lesson on magnetism, Parts I and II should be separated by a lesson developing a quantitative model for the magnetic field of a wire.]

- ▶ In Parts I (A) and (B), students explore some basic properties of magnetic fields. The instructor wanders among the students, asking questions to help them focus on relevant phenomena.
- ▶ In Part I(C), students are asked to design experiments to explore an area of common misconception: the cause of magnetic attraction. The questions guiding the inquiry are not directly student generated, but the methods to answer those questions are significantly under students' control. Some particular techniques, such as the use of a Faraday cage, must either be directly suggested or can be motivated by a recent review of properties of electric fields.
- ▶ In Part I(D), students receive more guidance to allow them to develop a representation of the magnetic field inside a magnet. In Part I(E), students are prompted to make the observations needed to allow them to create a representation of the magnetic field due to a current-carrying wire. In order to ensure sufficient teacher guidance in subpart (D) while keeping subpart (E) mostly student guided, it may be best to provide two separate stations with setups for each activity so that students can rotate between them. Alternatively, subpart (D) can be carried out as a demonstration with the class. If this is a first exploration, and the concepts are new, whole-class demonstration is recommended.

In between the implementation of Parts I and II, students should have a lesson in developing quantitative models for magnetic fields, or a reading and homework, if Part I was students' introduction to magnetic fields. If class time is an issue, planning the investigation for Part II can be given as homework. Students could then make brief whiteboard presentations to the group discussing their chosen methods.

In Part II, students carry out a quantitative exploration of magnetic fields.

[**NOTE:** This can take 50–90 minutes, depending on the extensions pursued and the equipment available to students.] Again, the major guiding questions are given to them, but students must figure out exactly how to do this activity, what measurements need to be made, and how the data should be analyzed. The activity develops scientific practices beyond those associated with the learning objectives related to magnetic fields.

Connections to the AP Physics 2 Curriculum Framework

Big Idea 2 Fields existing in space can be used to explain interactions.

Enduring Understanding	Learning Objectives
2.D: A magnetic field is caused by a magnet or a moving electrically charged object. Magnetic fields observed in nature always seem to be produced either by moving charged objects or by magnetic dipoles or combinations of dipoles and never by single poles.	2.D.2.1 The student is able to create a verbal or visual representation of a magnetic field around a long straight wire or a pair of parallel wires. (Science Practice 1.1)
	2.D.3.1 The student is able to describe the orientation of a magnetic dipole placed in a magnetic field in general and the particular cases of a compass in the magnetic field of the Earth and iron filings surrounding a bar magnet. (Science Practice 1.2)
	2.D.4.1 The student is able to use the representation of magnetic domains to qualitatively analyze the magnetic behavior of a bar magnet composed of ferromagnetic material. (Science Practice 1.4)

[**NOTE:** In addition to those listed in the learning objectives above, Science Practices 2.2, 4.2, 4.3, 5.1, and 7.1 are also addressed in this investigation.]

Skills and Practices Taught/Emphasized in This Investigation

Science Practices	Activities
1.1 The student can <i>create representations and models</i> of natural or man-made phenomena and systems in the domain.	In Part I of the investigation, students learn to create representations for a variety of magnetic fields.
1.2 The student can <i>describe representations and models</i> of natural or man-made phenomena and systems in the domain.	In Parts I and II, students identify relevant information about their representations and models and use it to formulate descriptions of each.

Science Practices	Activities
1.4 The student can <i>use representations and models</i> to analyze situations or solve problems qualitatively and quantitatively.	In Part II, students create representations for the fields and use these representations to determine what measurements are necessary.
2.2 The student can <i>apply mathematical routines</i> to quantities that describe natural phenomena.	The extension is quantitative and requires a number of calculations.
4.2 The student can <i>design a plan</i> for collecting data to answer a particular scientific question.	In Part I (B) and (C) and Part II, students design plans to collect data, although in Part I, the data are qualitative.
4.3 The student can <i>collect data</i> to answer a particular scientific question.	In each part of the activities, students make observations that allow them to answer scientific questions.
5.1 The student can <i>analyze data</i> to identify patterns or relationships.	In Part II, students carry out a semiquantitative analysis to understand addition of vector fields. They must analyze data to determine magnetic field in the extension.
7.1 The student can <i>connect phenomena and models</i> across spatial and temporal scales.	In Part I(D), students relate the field of a set of magnets to the behavior of magnetic domains in order to understand the field inside a magnet.

[NOTE: Students should be keeping artifacts (lab notebook, portfolio, etc.) that may be used as evidence when trying to get lab credit at some institutions.]

Equipment and Materials

Per lab group:

- ▶ 6–10 small compasses
- ▶ Three or more bar and horseshoe magnets of various sizes and shapes
- ▶ 6–10 1 3/8-inch unmarked bar magnets (it is very important to have small magnets available)
- ▶ Container, such as a salt shaker, filled with iron filings
- ▶ Sheet of paper, transparency, plastic zipper bag, or sheet protector
- ▶ Pith ball or paper clip hung on an insulated string
- ▶ Rubber rod or PVC pipe (for making charged rods)
- ▶ Glass or acrylic rod
- ▶ Rabbit fur or other material (for negatively charging the rods or PVC pipe)
- ▶ Silk or equivalent material (for positively charging the glass or acrylic rods)
- ▶ Styrofoam cup

- ▶ Piece of aluminum foil (large enough to cover a Styrofoam cup)
- ▶ Battery holders
- ▶ 10–15 copper wires (16–18 gauge) with alligator clips
- ▶ Switch
- ▶ 6–10 pieces of string to hang magnets
- ▶ Magnaprobe (optional: a small alnico bar magnet mounted in a gimbal that rotates in 3D so that all x , y , and z coordinates can be mapped)
- ▶ Magnetic field probe
- ▶ (Optional) 3 × 3-inch sheet of magnetically sensitive film (for increased variety of observations)

For the extension:

- ▶ Linear variable resistor
- ▶ Ammeter

For Part I(D) and 1(E) of the investigation (each setup as a single station, students may bring the compasses from one to the other):

- ▶ 20 ceramic bar magnets (1 7/8 × 7/8 × 3/8 inches) to form a large rectangular magnet
- ▶ Flat piece of wood or cardboard (approximately 6 × 6 inches) with a hole in the middle for wire to pass through to serve as a platform for compasses
- ▶ Clamp
- ▶ Rod stand to support clamps to hold the cardboard or wood
- ▶ 8–10 1.5-volt D-cell batteries or another power supply
- ▶ Two 22-gauge wires to attach power supply to wire (optional)

Timing and Length of Investigation

- ▶ **Teacher Preparation/Set-up:** 15–20 minutes

This is the time needed to set up the equipment, assuming everything is available at your school.

- ▶ **Student Investigation:** 130–160 minutes
- ▶ **Part I: Qualitative Investigations** 50–70 minutes (depending on if this part of the investigation serves as an introduction to magnetic fields)
- ▶ **Part II: Quantitative Investigations** 80–90 minutes (depending on if the design of the data collection procedures is assigned as homework)

Design of procedure: 30 minutes

Data collection: 30 minutes

Data analysis: 20–30 minutes (depending on if they have access to magnetic probes or must measure Earth’s magnetic field relative to the field of a long straight wire)

- ▶ **Postlab Discussion:** 30 minutes
- ▶ **Total Time:** approximately 3–3.5 hours

Safety

Warn students that it is possible to get pinched as they manipulate magnets; the ceramic magnets in particular are quite strong and the force of attraction increases rapidly as the separation decreases. Otherwise, there are no specific safety concerns for this lab. General lab safety guidelines should always be observed.

Preparation and Prelab

While students are generally very familiar with magnets, they will often hold some common beliefs that are not consistent with the scientific view. You could have an introductory discussion with students to address these misconceptions, but if time allows, it is probably more productive to allow students to do the qualitative Part I of this activity as an exploration in order to gain a more scientific view. This requires careful observation and questioning as students investigate.

If you wish to pretest students on their understanding, you will find several good questions to pose in “Magnetism,” “Magnetic Field of a Current-Carrying Wire,” “Surveying Students’ Conceptual Knowledge of Electricity and Magnetism,” and “Arkansas Conceptual Electricity and Magnetism Conceptual Inventory Construction and Self-Testing Site” (see Supplemental Resources). “PHYS 1404” has two examples of what homework questions might look like early in students’ study of magnetic fields, and “Magnet and Compass” and “Magnets and Electromagnets” provide simulations students can use to explore magnetic fields further (see Supplemental Resources for all).

The Investigation

Part I: Qualitative Investigations of Magnetic Fields

Start by hanging 1 3/8-inch unmarked bar magnets from the ceiling and letting them come to equilibrium. Discuss the meaning of *north-seeking* pole and *south-seeking* pole in terms of a magnet, and ask the students to label the poles. Then give them a compass and discuss which is the “north” end and which is the “south” end. This should lead to a discussion of the difference between magnetic and geographic north. Once students are clear about how the poles of a compass are labeled, they can use the compass to explore the magnetic behavior of other systems, including bar magnets and current-carrying wires.

Part I(A): Exploring the magnetic field of Earth

In this part, students explore qualitatively Earth's magnetic field. One way to do this activity is to use the small magnets hung from the ceiling at various points in the room. Magnaprobos, which allow rotation in three dimensions, can also be used. The magnets hanging from the ceiling or the Magnaprobos should all point in the same direction. One note of caution: in some buildings, the steel in the walls is an iron alloy that will attract a magnet. Magnets near the steel will not point in the direction of Earth's field, which should either be avoided or used for discussion. The concept of superposition of the field of permanent magnets and Earth's field can also be explored here. To do this, ask students to explore the following questions:

- ▶ How does the direction of a small magnet suspended in Earth's field change when a permanent magnet is brought nearby?
- ▶ How close does it have to be to see the superposition? When does one field dominate over the other?

Part I(B): Exploring the magnetic field of a magnet

In this next activity you may choose to have students explore the behavior of compasses placed at different locations and distances away from a bar (or other shaped) magnet. Ask students if they have information on the existence of a magnetic field and its strength or direction based on their observations. Be sure to ask them to observe how quickly or slowly the compasses “lock” into position and if that gives them any information on the strength of the field.

Students can also use iron filings or magnetically sensitive film to explore the magnetic field (see “Magnetic Field Viewing Cards” and the two YouTube videos in Supplemental Resources for examples). The iron filings will not help with the direction of the magnetic field, but they will help with the strength of the field and the concept of field lines (if introduced). If students use iron filings, make sure they place any magnet to be studied either under a sheet of paper or transparency or inside a sheet protector or plastic zip-lock bag, so that the filings do not come into direct contact with the magnet (the sheet of paper might create the best contrast to see the pattern created by the filings). Magnetically sensitive film can help with the direction of the field that is perpendicular or parallel to the film. Have students draw a picture using field vectors at six to ten points in space around the magnet to indicate the strength of the field at various locations around the magnet. It is useful to explore the fields of different shaped magnets and combinations of magnets (e.g., between like and unlike poles).

Part I(C): Exploring magnetic poles

In this activity, students develop experiments to determine if magnetic poles are (or behave as) positive and negative charges. [NOTE: If students need a refresher on electrostatics before beginning this section, you might choose to either review the operational definition of charge and the behavior of objects in the presence of a charge, or provide guidance to each group as they explore various options.]

Ask the students to design experiments that would either support or prove incorrect the hypothesis that the north and south ends of a magnet act as a cluster of positive or negative charges. They should write out their predictions for positive and negative charges and for north and south poles in simple situations. For example, they could predict the attraction or repulsion of a charged (or uncharged) pith ball by a charged rod, and predict the behavior of the pith ball (charged or uncharged) near a north or south magnetic pole. Once they have completed the predictions, they carry out the experiments. A charged pith ball will attract equally to both ends of a metallic magnet, so make sure students using such magnets test their predictions at both poles.

Direct students to explore the interaction of a charged pith ball or paper clip hung inside a Faraday cage with a charged rod outside the Faraday cage; then with a magnetic pole outside the Faraday cage. A simple example of a Faraday cage is a paper cup covered in foil. The students should observe the behavior of both north and south magnetic poles and positively and negatively charged rods. They can also observe the behavior with just the Styrofoam cup (not coated with foil). They should perform enough experiments so that they consistently observe (and come to understand) that north and south poles are not a cluster of positive and negative charges. It is imperative that they make sure the pith ball or paper clip is not too close to the upper edge of the Faraday cage, or the shielding will not be effective. If you did not cover the Faraday cage in your discussions on electric fields and conductors, this is a good time to ask students what they predict the electric field to be inside a conductor, and develop an explanation of the behavior of the Faraday cage.

Part I(D): Determining magnitude and direction of a magnetic field (superposition of magnetic fields)

In this activity, students are challenged to determine the magnitude and direction of the field inside a magnet. [NOTE: Students might need significant direction with this activity in order to relate the phenomena they observe with the superposition of fields due to multiple magnets. This may be most effectively done as a demonstration with strong student involvement followed by a class discussion. Another option would be to have each group cycle through this station (in parallel with students at the current-carrying wire station (see Part I(E)), which will not need as much teacher direction) and have each group create a whiteboard representation of the results of their exploration. This way you can check that they have developed the correct understanding while they are still in the activity.]

One way to approach this part of the investigation is to use the concept of superposition of magnetic fields. First, ask students to observe the superposition of fields outside of magnets by observing the change in direction of compass needles near a magnet when a second or third magnet is brought close to the first. If done as a whole group, use a compass that is clear on both sides and place it on an overhead along with the magnets, or use any compass with an Elmo-like projection system. Then, have students stack the twenty ceramic bar magnets to simulate a bar magnet that can be “broken” so as to enable them to “see” the field inside. The direction of the field inside can be determined by the following process:

1. With the stack of magnets in the shape of a bar magnet lying horizontally on a table, remove half of the stack and replace it with a small compass at the end of the remaining stack.
2. Observe the direction of the field caused by the half of the magnet on the table.
3. Remove the compass and replace the half that was removed.
4. Remove the other half and replace it with the compass at the end of the stack now on the table. (This will allow an observation of the direction of the magnetic field at approximately the same position caused by the second half of the stack.)
5. By superposition, the field inside the total stack, with both halves together, must be the sum of the fields caused by each stack independently.
6. To help students see that the field is stronger when both halves are together, be sure students observe that the field varies from straight out from the end of the bar magnet more quickly (for magnets placed perpendicular to Earth's field) as they weaken the magnet, and relate this to the net force on the needle.

Students determine that the field inside of a magnet points south to north and that it should be quite strong. This type of analysis is often presented in textbooks in a discussion of magnetism and magnetic domains at the microscopic level, but this activity provides a way to analyze magnetic fields macroscopically. More details and pictures of a setup can be found in a number of available teaching materials, such as the “Magnetism” and “PHYS 1404” (see Supplemental Resources).

Part I(E): Exploring the magnetic field of a current-carrying wire

In this final part of Part I, students observe qualitatively the field of a current-carrying wire using compasses.

[NOTE: Since this activity might require a relatively high current and use a significant amount of table space, it is beneficial to setup a separate station for it and let the student groups rotate through as they complete the previous activities.]

Setup a circuit with the D-cell batteries or a power supply, a switch, and low resistance. Pass the wire vertically through a hole in a piece of cardboard or a piece of wood, supported by clamps and a stand, which the compasses can rest on. For images of a setup, see “PHYS 1404” and “Magnetic Field of a Current-Carrying Wire” in Supplemental Resources. The switch should only be closed for brief periods as observations are being made.

Students should note the direction of the magnetic field when there is no current through the wire. When the switch is closed, the compasses will point in the direction of the magnetic field of the wire (the current must be large enough to make Earth's field irrelevant). The switch should be held down just long enough to see the effect and then opened, or the batteries will run down quite quickly. The batteries or power supply can then be turned around in order to observe the direction of the magnetic field when the direction of the current is reversed. Encourage students to draw a picture of the wire using magnetic field vectors at various points around the wire to indicate the strength of the field, which as previously observed is qualitatively determined by how quickly the compass aligns with the field. Ask students to draw both side and end views of the wire. [NOTE: With fewer batteries, or as batteries run down, the field may not be strong enough to make qualitative observations of the decrease in the magnetic field with distance from the wire.]

Part II: Quantitative Investigations of Magnetic Fields

In this part of the investigation, students measure the magnitude of the magnetic fields of various combinations of magnets, using a magnetic field sensor. This should be done at various distances from the magnets. Different sensors work in different ways, so it is important that you properly instruct students in their use.

While measuring the magnitude of a magnet's magnetic field, it is necessary to take Earth's field into account, in order to obtain just the field of the magnet. Before students design their data-collection procedures (either as homework or at the beginning of this activity), ask them to figure out different ways to do this. One option is to take measurements on both sides of the magnet: the first on the side where the direction of the Earth's field is opposite that of the magnet's field, and the second on the side where the direction of the Earth's field is in the same direction as the magnet's field. The Earth's field will cancel out when the two measurements are added together, yielding just twice the magnitude of the desired field. Other ways to obtain the field of the magnet include zeroing the sensor far from the magnet, fixing the sensor in one location and zeroing it, and then moving the magnet closer to it at different locations; or taping the sensor to the table, and then moving the bar magnet's N end to various distances along a line that is normal to the sensor surface.

[NOTE: Before proceeding, ask for volunteers to present their draft procedures to the class, and solicit feedback from the various groups.]

During the investigation, the students should take measurements in the following manner and sequence:

1. Take measurements surrounding one bar magnet.
2. Repeat the same measurements for a different bar magnet.
3. Place the first magnet on top of the second and repeat the same measurements.
4. Reverse the orientation of the top magnet and repeat the measurements.

Instruct students to create a vector field representation to semiquantitatively justify the results of their measurements. Additional magnets can be stacked to further vary the field. Ask students to make predictions about what they expect to measure before taking additional measurements.

Extension

Once students have studied the form of the equation for the magnetic field of a straight wire in class, as an extension they can measure the horizontal component of Earth's field using a current-carrying wire as a reference (finding the magnetic field from the equation for a long current-carrying wire at a given distance and current) by determining the direction of Earth's magnetic field, placing the wire such that the horizontal field produced by the wire is perpendicular to Earth's field, and varying the current (measured by an ammeter) in the wire until a compass placed next to the center of the wire (so the long wire approximation is most valid) is deflected to an angle 45 degrees from Earth's field. Students can plan the details of this measurement and for other angles. This is just an example: at 45 degrees the magnitude of the two fields are equal so the analysis is simplified greatly.

One possible source of error here is that the surface on which the experiment is carried out may contain materials that can become magnetized. Discussing the impact this would have on their measurements helps students achieve the AP Physics 2: Algebra-Based goal of being able to discuss what happens when some parameter of a physical situation is changed. It always helps to ask students to remember to make careful observations and consider their control variables.

Common Student Challenges

This lab is useful because by carrying out the qualitative and quantitative observations and measurements, students, through their observations, overcome the challenges many still face after instruction. Magnetism is a subject in which some prior beliefs exist that should be altered, and this exploration also serves as a place to help students in several areas that they often have difficulty: dealing with superposition of vectors, graphing data, and interpreting graphs.

In particular, Part I(C) provides students the opportunity to demonstrate that magnetic poles are not and do not behave as clusters of positive and negative charges. Throughout all of Part I, students who have not yet studied magnetism have the opportunity to observe magnetic behavior and begin to build mental models of the magnetic field for the first time. They will develop a better understanding of the strength and the direction of the field inside a magnet, how a measured field is the superposition of the existing fields, and the strength and direction of Earth's magnetic field. If they have studied magnetism, they will come to understand some of the challenges of the material through the laboratory observations.

Magnetic field explorations are often very interesting to students, as the macroscopic observations of the noncontact magnetic force are often exciting. You may find that students want to just play and observe magnetic effects — a little of this is encouraged before serious observations and data taking begins. After working through the lab, students should have a better understanding of magnetic fields and have improved their measurement skills. They should also be able to answer the guiding questions found in the Analyzing Results section of this investigation.

If students are still struggling with particular challenges during the lab, such as the field inside a magnet or the superposition of fields, ask probing questions at that point. In the later parts of the lab, ask students explicitly about what they are graphing and why, and what information can be gained from the graph.

Analyzing Results

The qualitative results can be analyzed by having students draw magnetic field vectors or magnetic field lines for the various magnets or current-carrying wires they observe. They can also discuss the strength and direction of the field at various points away from a magnet or current-carrying wire. It is particularly useful to ask students explicit questions about challenging topics. The guiding questions for this lab include:

- ▶ Based on qualitative laboratory explorations, what evidence do we have of the existence of magnetic fields, and how can the magnitude and direction of the fields be represented by either field lines or vectors?
- ▶ Are magnetic poles the same as positive and negative charges, and what experiments could be done to demonstrate this?
- ▶ How can we use the concept of superposition of fields to determine the strength of the magnetic field inside a magnet?
- ▶ How can we qualitatively and quantitatively measure the strength and determine the direction of Earth's magnetic field?
- ▶ Are permanent magnets the only way to create a magnetic field?
- ▶ Do stationary or moving charges give rise to a magnetic field?
- ▶ Do we have to account for Earth's magnetic field when measuring the magnetic field of magnets or current-carrying wires?
- ▶ How could we use the magnetic field of a current-carrying wire to measure the magnetic field of the earth?

Assessing Student Understanding

At the end of the investigation, students answer the questions that guide the investigation. They should understand and be able to articulate how to determine the magnitude and direction of the magnetic field at a point in space qualitatively, and how to make a quantitative measurement of the strength of the magnetic field.

They should understand and/or be able to:

- ▶ Articulate that magnetic poles are not clusters of positive or negative charge;
- ▶ Visualize the magnitude and direction of the magnetic field due to a magnet and due to a current-carrying wire at various points in space and be able to draw pictures using magnetic field vectors to represent the field at those points in space;
- ▶ Conceptualize the magnitude and direction of Earth's magnetic field at various points in space and be able to experimentally measure the strength of the field and determine its direction;
- ▶ Articulate the superposition of magnetic fields; and
- ▶ Use the superposition of magnetic fields to design an experiment to measure an unknown field, given a reference field.

[NOTE: Further questions useful for assessment can be found in various references listed in Supplemental Resources.]

Assessing the Science Practices

Science Practice 1.1 The student can *create representations and models* of natural or man-made phenomena and systems in the domain.

Proficient	<p>Creates a representation that:</p> <p>(1) is appropriate and correct for representing the magnetic field of a current-carrying wire (magnetic field vectors form concentric circles and have no component toward the wire);</p> <p>(2) includes features representing all essential aspects of the phenomenon (magnitude of the magnetic field is proportional to the magnitude of the current, strength of the field decreases as the distance from the wire increases, and the direction of the field is determined by a right-hand rule);</p> <p>(3) contains an appropriate level of detail (indicating the subtraction or addition of field's different sources); is accurate;</p> <p>(4) accurately labels the elements of the representation (the current and the magnetic field, and indicating how the magnitude of the field decreases with distance from the wire or wires);</p> <p>(5) expresses a causal explanation (i.e. that the magnetic field is caused by the current and decreases as the distance from the current increases); and</p> <p>(6) correctly superposes the magnetic fields to find the direction of net field.</p>
Nearly Proficient	<p>Creates a representation but does not show all of the main features of the phenomenon; or the representation is missing one necessary detail; or the representation accounts for the most important features of the phenomenon and is experimentally testable, but the limitations and assumptions are not mentioned.</p>
On the Path to Proficiency	<p>Creates a representation but more than one main feature of the phenomenon is not represented; or the representation is missing more than one necessary detail; or the representation does not account for the most important features of the phenomenon and is not experimentally testable.</p>
An Attempt	<p>Creates a representation but many of the main features of the phenomenon are not represented; or the representation is missing many of the necessary details; or the representation does not account for the most important features of the phenomenon and is not experimentally testable.</p>

Science Practice 1.2 The student can *describe representations and models* of natural or man-made phenomena and systems in the domain.

Proficient	Includes the following in describing the model: (1) a compass needle is a permanent magnetic dipole with north and south polarity; (2) iron filings in a magnetic field become induced magnetic dipoles; (3) dipole orientation is antiparallel with field direction; and (4) the magnetic north of a compass needle points toward the magnetic south of Earth, which is near Earth’s geographic north pole.
Nearly Proficient	Extracts relevant information from the representation but one important piece of information is missing, or while describing a model, makes one important omission.
On the Path to Proficiency	Extracts information from the representation but focuses on irrelevant features, or while describing a model, omits multiple important aspects.
An Attempt	Extracts incomplete information from the representation and focuses on irrelevant features, and while attempting to describe a model, omits multiple important aspects.

Science Practice 1.4 The student can *use representations and models* to analyze situations or solve problems qualitatively and quantitatively.

Proficient	Uses the model correctly, including: (1) accurate representation of the domain model of ferromagnetic materials; (2) accurate translation between the structure of a bar magnet and the magnetic domain representation; (3) accurate predictions based on the magnetic domain representation (if a bar magnet is broken in half, both halves are magnetic dipoles and have magnetic fields; no magnetic north pole has ever been isolated from a south pole).
Nearly Proficient	Utilizes a domain model and uses it to predict how the bar magnets together act like a single magnet, but a feature of the prediction is missing or inaccurate.
On the Path to Proficiency	Utilizes a domain model to predict how the fields of two bar magnets add or how bar magnets in the same direction together act like a single magnet, but has trouble considering multiple magnets or cases when all domains are not aligned.
An Attempt	Utilizes a domain model but cannot accurately use it to predict how the bar magnets together act like a single magnet.

Science Practice 2.2 The student can *apply mathematical routines* to quantities that describe natural phenomena (extension).

Proficient	Substitutes values into the developed equation and correctly solves by manipulating the variables in the equation.
Nearly Proficient	Creates an accurate mathematical representation of the form of the appropriate magnetic field for the method chosen and the vector relationship between the reference field and the field under study.
On the Path to Proficiency	Uses appropriate terms or symbols in developing an equation (mathematical representation), but there is an error in the form of the equation.
An Attempt	Attempts to create a mathematical representation, but significant errors in the use of symbols, equations, etc. are present.

Science Practice 4.2 The student can *design a plan* for collecting data to answer a particular scientific question.

Proficient	Part II: Designs an appropriate collection plan to answer the question with appropriate qualitative measures and adequate justification for the selection of equipment.
Nearly Proficient	Part II: Designs an appropriate collection plan to answer the question with appropriate qualitative measures.
On the Path to Proficiency	Comes up with some aspects of a plan to collect data in response to the question, but the plan is not adequate to answer the question.
An Attempt	Attempts to design a plan to collect data, but the plan is not aligned to the question or problem being investigated and it contains significant misalignments and errors.

Science Practice 4.3 The student can *collect data* to answer a particular scientific question.

Proficient	Makes observations that allow for answering scientific questions in each part of the activity.
Nearly Proficient	Implements all parts of the plan to collect data but without sufficient care, or collects data with appropriate care but not for all parts of the planned collection. The insufficiencies in data collection weaken the conclusion that can be drawn from the data.
On the Path to Proficiency	Implements some aspects of his or her plan to collect data, but the data was not taken with sufficient care or contained some mistakes or unnecessary inaccuracies.
An Attempt	Attempts the collection of data, but the data is not appropriate for the investigation and the collection strategies contain major errors.

Science Practice 5.1 The student can *analyze data* to identify patterns or relationships.

Proficient	Identifies the patterns in the data relevant to the question of the relationships between individual fields and a resultant field or between the direction of field of interest and direction of reference field in the extension. Uses appropriate terminology to describe the relationships.
Nearly Proficient	Identifies the directions from the compass and applies the vector representation to add fields of individual magnets, but makes some errors.
On the Path to Proficiency	Uses the direction of the compass to identify the direction of a field of a single magnet, but cannot use a vector representation to show addition of vectors.
An Attempt	Attempts to use data, but fails to identify any patterns and illustrates many errors when representing vectors.

Science Practice 7.1 The student can *connect phenomena and models* across spatial and temporal scales.

Proficient	Explains the relationship of the external observed field to the internal structure of the magnet as being made of multiple magnetic domains, relating this to the addition of many magnets and that the magnetic field represents the direction of the net field, so that all the individual magnets do not have to be aligned.
Nearly Proficient	Explains a relationship between the external observed field and the internal structure of the magnet as being multiple magnetic domains but in terms of all of the domains being aligned within the magnet.
On the Path to Proficiency	Describes that magnets can be made up of smaller magnets but in terms of physical magnets, not at the scale of magnetic domains.
An Attempt	Attempts to describe the relationship between the external magnetic field to the concept of internal magnetic domains, but many errors are present.

Supplemental Resources

“Arkansas Conceptual Electricity and Magnetism Conceptual Inventory Construction and Self-Testing Site.” University of Arkansas. Accessed September 1, 2014. <http://physinfo.uark.edu/inventory>.

Giordano, Nicholas J. “Applications: DNA Fingerprinting.” In *College Physics: Reasoning and Relationships*. Belmont, California: Brooks/Cole, 2010.

Kanim, Stephen, and John R. Thompson. “Magnetic Field Viewing Cards.” *The Physics Teacher* 43, no. 6 (2005): 355-359.

“Magnet and Compass.” PhET. University of Colorado Boulder. Accessed September 1, 2014. <http://phet.colorado.edu/en/simulation/magnet-and-compass>.

“Magnetic Viewing Film, Looking at Zen Magnets.” YouTube. Video, 3:53. Accessed September 1, 2014. <http://www.youtube.com/watch?v=AMggixEu0q0>.

“Magnets and Electromagnets.” PhET. University of Colorado Boulder. Accessed September 1, 2014. <http://phet.colorado.edu/en/simulation/magnets-and-electromagnets>.

Maloney, David P. “Charged poles?” *Physics Education* 20, no. 6 (1985) 310–316.

Maloney, D.P., T.L. O’Kuma, C.J. Hieggelke, and A. Van Heuvelen. “Surveying Students’ Conceptual Knowledge of Electricity and Magnetism.” *Physics Education Research Supplement to the American Journal of Physics* 69, no. 7 (2001): S12–S23.

McDermott, Lillian C., Peter S. Shaffer, and the Physics Education Group at the University of Washington. “Magnetism.” In *Tutorials in Introductory Physics*. Upper Saddle River, NJ: Pearson, 2012.

McDermott, Lillian C., and the Physics Education Group at the University of Washington. “Magnetic Field of a Current-Carrying Wire.” In *Physics by Inquiry: Volume II*. Hoboken, NJ: John Wiley and Sons, Inc., 1996.

“See Invisible Magnetic Fields with Magne-View Film.” YouTube. Video, 2:22. Accessed September 1, 2014. <http://www.youtube.com/watch?v=uLHl9mnRSbc>.

Stewart, Gay B. “Measuring Earth’s Magnetic Field Simply.” *The Physics Teacher*, 38, no. 2 (2000):113–114.

Thacker, Beth. “PHYS 1404.” Department of Physics. Texas Tech University. Accessed September 1, 2014. <http://www.phys.ttu.edu/~batcam/Courses/sem2.html>.

AP Physics 2 Investigation 5: Electromagnetic Induction

What factors relate to the production of an emf in the interaction of a magnetic field and a coil of wire?

Central Challenge

This investigation introduces the topic of electromagnetic induction and provides a solid experiential background for the discussion of magnetic flux, Faraday's law of induction, and Lenz's law. Students are asked to design experiments to determine the variables that determine the emf that can be induced in a coil by a permanent magnet.

Background

Magnetic flux is the scalar product of the magnetic field (\vec{B}) through a loop and the area vector associated with that loop. The area vector (\vec{A}) is a vector that is perpendicular to the plane of the loop and has a magnitude that is equal to the area of the loop. This can be expressed mathematically as $\Phi = \vec{B} \cdot \vec{A}$. If a uniform magnetic field is perpendicular to the plane of the loop, then the flux through the loop is simply the product of the magnitude of the magnetic field and the area of the loop ($\Phi = BA$). When the magnetic flux through a loop is changing, a current is induced in the loop. Even if the loop is not closed (i.e., has a small gap in it), an induced emf is created in the loop. This induced emf is proportional to the rate of change of the flux. If a coil consists of several loops, the induced emf in the coil is proportional not only to the rate of change of flux through each loop, but also to the number of loops. This is Faraday's law. In equation form, it is $\mathcal{E} = -N \frac{\Delta\Phi}{\Delta t}$, where \mathcal{E} is the induced emf and N is the number of loops in the coil.

Real-World Application

There are so many applications of the principles studied in this investigation that a short list should invoke many others. Electric generators and transformers in the power grid are perhaps the most relevant applications. Back emf is also a very important factor in the design and operation of all electric motors. Many of the new designs for efficient hybrid and electric automobiles include the use of the braking system to transfer the mechanical energy of the moving vehicle into electrical energy that can recharge the batteries. The principle of induction is used in some types of microphones and in the magnetic coil pickups of electric guitars.

Inquiry Overview

This is a guided-inquiry investigation in which students construct small coils and use a voltmeter to measure the induced emf when small neodymium magnets are moved in and through the coil. Students need to come up with a list of variables (e.g., coil size, magnet strength, speed) that may affect the emf induced in a small coil when a magnet is moved near the coil. Then they need to design and execute experiments to vary those factors and determine if and how they affect the emf generated.

Connections to the AP Physics 2 Curriculum

Big Idea 2 Fields existing in space can be used to explain interactions.

Enduring Understanding

2.D A magnetic field is caused by a magnet or a moving electrically charged object. Magnetic fields observed in nature always seem to be produced either by moving charged objects or by magnetic dipoles or combinations of dipoles and never by single poles.

Learning Objectives

2.D.3.1 The student is able to describe the orientation of a magnetic dipole placed in a magnetic field in general and the particular cases of a compass in the magnetic field of the Earth and iron filings surrounding a bar magnet. (Science Practice 1.2)

Big Idea 3 The interactions of an object with other objects can be described by forces.

Enduring Understanding

3.A All forces share certain common characteristics when considered by observers in inertial reference frames.

Learning Objectives

3.A.1.3 The student is able to analyze experimental data describing the motion of an object and is able to express the results of the analysis using narrative, mathematical, and graphical representations. (Science Practice 5.1)

Big Idea 4 Interactions between systems can result in changes in those systems.

Enduring Understanding

4.E The electric and magnetic properties of a system can change in response to the presence of, or changes in, other objects or systems.

Learning Objectives

4.E.2.1 The student is able to construct an explanation of the function of a simple electromagnetic device in which an induced emf is produced by a changing magnetic flux through an area defined by a current loop (i.e., a simple microphone or generator) or of the effect on behavior of a device in which an induced emf is produced by a constant magnetic field through a changing area. (Science Practice 6.4)

[NOTE: In addition to those listed in the learning objectives above, Science Practice 4.3 is also addressed in this investigation.]

Skills and Practices Taught/Emphasized in This Investigation

Skills Practices	Activities
1.2 The student can <i>describe representations and models</i> of natural or man-made phenomena and systems in the domain.	Students describe a magnetic field around a neodymium magnet.
4.3 The student can <i>collect data</i> to answer a particular scientific question.	Students collect data on the effect of moving a magnet through a coil and inducing an emf. Students use a voltmeter to measure induced emf.
5.1 The student can <i>analyze data</i> to identify patterns or relationships.	Students analyze the data to identify patterns and relationships between the motion of a magnet and the emf induced in a coil.
6.4 The student can <i>evaluate alternative scientific explanations</i> .	Students examine alternate explanations for how an emf might be induced in a coil using a small neodymium magnet.

[NOTE: Students should be keeping artifacts (lab notebook, portfolio, etc.) that may be used as evidence when trying to get lab credit at some institutions.]

Equipment and Materials

Per lab group (two students):

- ▶ 5–6 meters of enameled magnet wire (100 meters can be purchased online or at most electronics retail stores for less than \$10)
- ▶ Plastic/cardboard tube to act as a base for winding the coil of wire, such as PVC pipe or very wide drinking straw (approximately 1/2-inch inside diameter and 2 inches is long enough)
- ▶ Plastic tube of larger diameter to wind a larger coil, such as a small prescription bottle (1-inch diameter and about 2 inches is long enough)
- ▶ Four or more neodymium axially polarized nickel-plated disc magnets ($5/16 \times 1/4$ inches) The exact number of magnets and their dimensions are not important so long as there is a sufficient quantity to separate them into at least two piles, so that the strength of each magnet group can be adjusted, and the diameters are narrow enough to be moved easily back and forth through the diameter of the smaller coil (such magnets are widely available on the web for about \$0.50 each).
- ▶ Digital multimeter (DMM) with a setting that will indicate to the tenths of a millivolt [NOTE: As an alternative, analog meters or a galvanometer may be used.]
- ▶ Pair of connecting wires, preferably with alligator clip connectors
- ▶ Electrical tape to secure leads

- ▶ Sandpaper to sand off ends of coated wire
- ▶ String to suspend magnets
- ▶ Masking tape
- ▶ Compasses
- ▶ (Optional) Two eightpenny or tenpenny nails

Extension:

- ▶ Two coils, one that fits inside the other
- ▶ Demonstration transformer
- ▶ Old AC to DC wall transformer to disassemble
- ▶ Digital multimeter with AC voltmeter capability or dedicated AC voltmeter

Timing and Length of Investigation

- ▶ **Teacher Preparation/Set-up:** 5–10 minutes

After the materials are ordered/gathered, the teacher preparation time is minimal.

- ▶ **Prelab:** 10–20 minutes

The prelab should be a short discussion or review of the fact that a current passing through a coil produces a magnetic field and that its sense can be determined by the right-hand rule. Emphasize that there will be no external source of emf used in this investigation. The purpose of this initial discussion is to start students thinking in terms of current direction, magnetic poles, and interactions. You might want to have the class identify a list of possible variables as part of the prelab. That could add another 10 minutes. If there is some concern about the time available for the actual investigation, some coils could be assembled during an extended prelab.

- ▶ **Student Investigation:** 60–70 minutes

This time will vary depending on the number of variables students identify and, more importantly, their skill winding a coil of wire. As a postlab you might want to bring the research together to discuss common findings and pose additional questions (e.g., “Would a different gauge wire produce different results?”). This would require another 15–20 minutes and could lead to an extension of the study as time allows.

- ▶ **Postlab Discussion:** 15–20 minutes
- ▶ **Total Time:** 1.5–2 hours

Safety

While there are no great dangers associated with this lab, students should be cautioned that these magnets are very strong and will accelerate toward each other or other metal objects very quickly and possibly cause unexpected and significant pinches to any skin that happens to be in the way.

The nickel coating on the magnets might chip and flake off if they are struck or dropped on hard surfaces or one another. The underlying magnetic material is then exposed to breaking up, so the magnets should be handled with care. Not a lot is known about the toxicity of these materials so it is a good idea to wash hands if exposed to disintegrating magnetic material. Individual sets of magnets are easily stored in small plastic prescription bottles to keep them separated.

Preparation and Prelab

Prior to beginning the investigation, students should establish a list of possible variables that determine the emf that can be induced in a coil by a permanent magnet, and go on to design coils and procedures to test those variables with the supplied materials. You might have to show students how to separate the magnets by sliding them apart and reconnecting them by sliding them back together. (See “Separating Neo Magnets” in Supplemental Resources.)

The Investigation

To begin, tell the students to find a way to identify and label the polarity of their magnet by reference to Earth’s magnetic field in the room. **[NOTE:** If they are given compasses, have students keep them at a relatively large distance from the magnets because the strong magnets used in this lab can ruin them. The compass will still work at a greater distance and help to identify the polarity. Because of the strength of the magnets, simply placing them on a smooth surface or suspending them horizontally from a thread will allow them to quickly line up with the Earth’s field.] Some smartphone apps can help identify the polarity of the magnet, but students should be careful not to bring the strong magnets too near their phones to prevent damaging them.

Next, with the appropriate materials, students construct simple coils to carry out their experiments. Depending on the color of the enamel on the wire, it might appear to students to be bare, so you might have to tell them to scrape or sand the coating off the end sections to connect the voltmeter. Students should design experiments to discover that the motion of the magnet through the coil along its axis will generate an emf. If a particular group doesn’t discover this, you may have to guide them in this direction.

Students may need some assistance using the digital multimeter. Suggest a setting of approximately 200 millivolts on the DMM to detect the emf. Also tell students that the sampling rate of the meter limits its response. Typically this rate might be five samples per second, so therefore the average speed with which the magnet moves through the coil should not be too fast for the meter. [NOTE: Some digital meters do not have the sensitivity to provide good readings. If this is the case, analog meters or a galvanometer may need to be used, but they have their limitations. It may be more difficult to gather data as the moment of inertia of the rotating coil in the meter can interfere, thus making the motion of the needle not as responsive to changes in current as a DMM may be. The traditional use of a galvanometer makes the connection of current and the change in flux. While this can be done, there are two factors that might make this a less effective lesson: 1) Changing the length of the coil will change the resistance so the current will respond to two variables, increased number of turns and increased resistance. This would be a poor example of experimental design even though the results of this semi-quantitative investigation are not likely to be significantly changed and 2) Faraday's law relates induced emf to rate of change of flux. Current is another step removed from the fundamental idea.]

One method of controlling the speed of the magnet through the coil is to have the coil propped up at a small angle as illustrated in Figure 1:

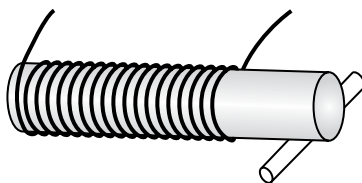

Figure 1

The angle should be such that the magnet, starting at the beginning of the coils, will just slide down the tube where it can be stopped before exiting by a finger placed over the lower end. This can be achieved by placing a small object under one end of the tube as shown. Depending on the material of the tube this could be something like a matchstick or a pencil. By doing five or six runs, a good indication of the relative size of the induced emf can be determined. Then the angle can be increased slightly and the procedure repeated.

An alternate method of moving the magnet slowly down the tube would be to hold a nail in one end of the horizontal coil and allow the force it exerts on the magnet to pull the magnet along the tube. Moving the nail closer to the magnet would produce a higher speed, and thus the speed could be varied to see the effect on the emf.

One end of the set of magnets can be placed on the head of the nail to provide a convenient axial handle, as illustrated in Figure 2:

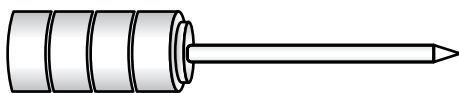

Figure 2

As students perform their experiments, remind them to keep careful records of all observations and keep track of the N-S orientation of the magnet, the direction of its motion, and the direction of the induced current as well as some rough numerical data for the range of emfs induced in each case.

Tell students that in some individual trials the sampling rate will be such that a measurement is missed and the meter will read zero. Regardless of the method used to move the magnets through the coil, students will probably notice that the magnet is actually accelerating, but it is the average speed that is important in enabling them to make qualitative conclusions. They should be told that they are not gathering exact quantitative data but merely using the average numerical readings of several trials to judge the effect of each variable they consider.

It is expected that they will be able to come up with their own list of variables, but if you have chosen not to make this part of the prelab discussion, you might need to guide them to identify and investigate some missed variables: strength of the magnetic field (number of discs in “series”), number of turns of wire in the coil, diameter of the coil, spacing of the windings — spread out or tight — more than one layer of windings, the effect of the speed of the motion of the magnet into/out of the coil, and the sign of the induced voltage for each motion. Students may inadvertently vary two quantities at the same time if they are not careful in winding the coils. For example, when comparing two different diameter tubes, students need to make sure that each tube has the same number of turns, the same spacing, etc.

Even though this is a qualitative lab, and does not lend itself to a quantitative error analysis, you should lead a discussion with students about methods of improving their observations to be certain that they are observing true effects. If they obtain an unexpected result, they should repeat the observation. If they still are not convinced they are observing accurately, they should ask you for confirmation, or to make sure their equipment is connected correctly.

Extension

Once students have an understanding of how a changing magnetic field can induce a current in a coil, the concept can be extended to a primary and secondary coil. Depending on student experience, this may work best as a teacher demonstration projected onto a larger screen for students to observe.

Alternating current is supplied to a larger coil. When a smaller coil with an AC voltmeter attached to it is inserted inside the larger coil, students should see a reading on the voltmeter. The changing magnetic field here is due to the changing direction of current from the alternating supply. From this, you can also demonstrate other related concepts, such as how inserting the secondary coil only halfway into the larger coil affects the reading.

You can also take apart a wall charger to show students how the input coil and output are not directly connected to each other, but that the output current is induced in the output line by a changing current (and changing magnetic field strength and direction) in the input coil.

Even though AC currents are not part of the curriculum, this extension has very common application in students' lives and fairly simply shows how current is induced in transformers.

Common Student Challenges

It is likely since this is an investigation to introduce the topic, students will still be having difficulties with the abstraction of the magnetic field. This provides some of the mystery and wonder of forces that do not appear to be anything like the attractions or repulsions that students have studied in other parts of the course. Their previous experiences combined with common intuitive understandings of how forces behave can make it difficult for students to understand what is happening. Spending a few minutes reviewing what they know about magnetic fields might help alleviate this. For example, have them draw the field around a bar magnet as a review or introduction to this lab. And have them review how to determine the polarity of a magnet, both by suspending it and allowing it to align with Earth's field and using a compass.

The two-fold idea that the changing magnetic field can exert a force on the charges in the conductors of the coil, and that the force is not in the direction of the field or even in the direction of its motion, can be overwhelming. Confusion about the magnitude of the flux as opposed to the rate of change of flux is also a common difficulty. Encourage students to see the cause and the effect, even though at this stage they cannot formulate it into something that seems to make sense. It can help to build intuition by starting with the example of a square loop of wire being moved into, through, and out of a uniform, constant magnetic field. Students can use the right-hand rule to see that there will be a net movement of charge (leading to current in a closed loop, or a potential difference in a loop with a gap) when one edge of the loop is outside of the field. There is no current when the loop is completely within the field because there is no net movement of charge. It is also important to show them that the same forces, and therefore currents and potential differences, are created if the loop remains constant and the magnetic field "moves."

Analyzing Results

For this type of open-ended investigation, there are many ways of recording/reporting the results. One way would be an organized individual report that might include the following:

- ▶ A preliminary list of the variables that might determine the emf generated in the coil (e.g., number of coil loops per given length, speed of the magnet through the coil, cross-sectional area of the coil, strength of the magnet).
- ▶ A description of the method to be used to investigate the effect of changing each variable. (Encourage students to use diagrams to clarify their descriptions/explanations.)
- ▶ A sentence or two describing the reasons, including estimated typical potential differences, as supporting evidence for the groups' conclusions regarding each variable.

- ▶ A final concluding essay making overall claims about the determining factors in terms of size and direction of the emf.

A postlab class discussion of the observations can serve to reinforce the conclusions. When a consensus is reached, with your guidance, each student should compile his or her individual reports of the results of the class investigation. Students might then begin to develop the relationship $\mathcal{E} = -N \frac{\Delta\Phi}{\Delta t}$.

Assessing Student Understanding

After completing this activity, students should be able to:

- ▶ Generate an emf using a magnet and a coil;
- ▶ Design an experiment to determine the factors that affect the magnitude of the emf in the coil;
- ▶ Make predictions about the direction of the induced emf in a coil based on the motion of a magnet through the coil;
- ▶ Explain that the induced emf depends on the number of turns of wire through which the magnetic field passes and the rate at which this occurs; and
- ▶ Discuss the effect of a difference in cross-sectional area on the rate at which the magnetic flux changes.

Assessing the Science Practices

Science Practice 1.2 The student can *describe representations and models* of natural or man-made phenomena and systems in the domain.

Proficient	Describes the magnetic field and the change in flux and how it relates to the induced emf in the coil.
Nearly Proficient	Describes the magnetic field of a magnet, and understands the difference between flux and field, but does not distinguish between flux and rate of change of flux.
On the Path to Proficiency	Describes the magnetic field of a magnet but has difficulty distinguishing between flux and field.
An Attempt	Creates an inaccurate description or representation of the magnetic field around a magnet.

Science Practice 4.3 The student can *collect data* to answer a particular scientific question.

Proficient	Creates an emf in a coil by moving a magnet. Makes accurate and complete observations of the induced emf for various motions of the magnet and various sizes of coils (including both relative strength of the emf and the direction).
Nearly Proficient	Makes mostly accurate measurements with a minor flaw or mistake in observation or measurement.
On the Path to Proficiency	Makes major measurement mistakes or inaccurate observations of the emf induced, such as failing to record the sign, or in the orientation of the magnet.
An Attempt	Cannot make any relevant or appropriate observations, and connects the voltmeter incorrectly.

Science Practice 5.1 The student can *analyze data* to identify patterns or relationships.

Proficient	Explains patterns of voltmeter readings to infer the relationships between the emf induced in different trials of varying complexity.
Nearly Proficient	Describes patterns of voltmeter reading, but cannot connect the voltmeter reading to the emf induced in complex trials.
On the Path to Proficiency	Identifies only the simplest patterns from the voltmeter readings due to induced emf and cannot draw conclusions from these patterns.
An Attempt	Cannot correctly organize the data to allow identification of any patterns.

Science Practice 6.4 The student can *make claims and predictions about natural phenomena* based on scientific theories and models.

Proficient	Makes claims and/or predictions regarding the magnitude and direction of the induced emf due to a moving magnet in a coil. Explains what factors affect the induced emf in the coil.
Nearly Proficient	Makes claims or predictions regarding the rate of change of flux and the emf induced with an occasional or minor error.
On the Path to Proficiency	Describes changing flux and induced emf without correct reasoning or justification and with some errors.
An Attempt	Identifies and articulates the results of induced emf with significant errors.

Supplemental Resources

“Faraday’s Electromagnetic Lab.” PhET. University of Colorado Boulder. Accessed September 1, 2014. <http://phet.colorado.edu/en/simulation/faraday>. [This interactive Java simulation provides a good postlab discussion and enables the students to “see” what is going on in this application of Faraday’s Law. It represents the magnetic field not as a series of lines but as a field of vectors/arrows, thereby reinforcing the use of such representations in AP Physics 1 and 2.]

“Faraday’s Magnetic Field Induction Experiment.” Michael W. Davidson. The Florida State University. Accessed September 1, 2014. <http://micro.magnet.fsu.edu/electromag/java/faraday2/index.html>. [Not as elaborate or interactive as the PhET simulation, this simple simulation could be used very effectively in a postlab discussion. It might best be used before the PhET simulation because it “shows it like it is” without visible fields or visible charge particles, and is a good transition from the student experiment to the model represented in the PhET simulation.]

John Belcher’s videos. YouTube. <http://www.youtube.com/user/ElectromagnetismAnim>.

“Separating Neo Magnets.” YouTube. Video, 9:27. Accessed September 1, 2014. <http://www.youtube.com/watch?v=GYiTjdKhRWg>. [This video about using neodymium magnets can help your students manipulate these strong magnets without damaging the magnets or pinching their fingers.]

“Visualizing Electricity and Magnetism at MIT.” Accessed September 1, 2014. http://web.mit.edu/8.02t/www/802TEAL3D/teal_tour.htm. [John Belcher’s field visualizations are really well done and several of them might be useful as part of the postlab discussion.]

This page is intentionally left blank.

AP Physics 2 Investigation 6: Geometric Optics

How do we find the focal length of a thin lens?

Central Challenge

In this investigation, students are given a converging lens and asked to make measurements that can be graphed to find the focal length of that lens.

Background

Lenses are formed by shaping glass or plastic into one of two general shapes. Lenses that are convex on both sides, and thus thicker in the middle than on the edges, take rays that are incident on the lens parallel to each other and converge them to a single point, called the *focal point*. These are called *converging lenses*. Lenses that are concave on both sides, and thus thinner in the middle and thicker on the edges, take rays that are incident on the lens parallel to each other and diverge them as if they came from a single focal point. These are called *diverging lenses* (in fact, in air, any lens that is thicker in the middle, for example a plano-convex lens, is a converging lens; and any lens that is thinner in the middle, for example a plano-concave lens, is a diverging lens).

Snell's law governs the way that rays are refracted through each lens. The path of light is reversible, so light rays that are incident through the focal point will be refracted parallel to the *principal axis* — a line that passes through the lens, perpendicular to the plane of the lens. We can use these facts to trace specific rays from an object through the lens to determine, qualitatively, where the image is formed.

We define the following terms:

- ▶ *image distance* — the distance from the image to the center of the lens
- ▶ *object distance* — the distance from the object to the center of the lens
- ▶ *focal length* — the distance from the focal point to the center of the lens

We can use the geometry of similar triangles to derive an equation that relates the image distance, object distance, and focal length (Equation 1). This is known as the lens equation.

$$\frac{1}{f} = \frac{1}{d_o} + \frac{1}{d_i}$$

Equation 1: Lens Equation

Real-World Application

Both diverging and converging lenses are used to correct vision, and many students are curious about how their glasses (or contact lenses) work. During the unit on optics, you can include a discussion about how the two types of lenses are used to correct vision, and how the focal length of each lens relates to how good (or poor) an individual's vision is. In particular, you could show how converging lenses are used for reading glasses. The focal length is long enough that the object distance is always less than the focal length, and the image produced is virtual, enlarged, and upright. Students could use ray boxes (which create parallel beams of light) to examine how their own glasses refract the light and determine for themselves whether they are diverging or converging.

You could also discuss how diverging lenses, which are used to correct near-sightedness, make virtual images that are always closer to the lens than the object. If you want to expand upon this activity, you could look into multi-lens systems. Multi-lens systems have many applications, including telescopes, binoculars, microscopes, and other optical instruments.

Inquiry Overview

This lab is designed to provide students a guided-inquiry experience: you give them the question to answer, and they design the experimental procedure. After students have gained experience using the lens equation, present them with a converging lens of unknown focal length. Students then design an experiment to determine the focal length of the converging lens, make a graph, and use the graph to determine the focal length.

If some students complete the above task in significantly less time than their peers, you can provide them with a diverging lens and ask them to find its focal length. As the diverging lens does not form real images, they will have to use the converging lens in a system with the diverging lens to create a real image and measure image and object distances. Alternatively, you could require all students to find the focal length of both lenses.

Connections to the AP Physics 2 Curriculum Framework

Big Idea 6 Waves can transfer energy and momentum from one location to another without the permanent transfer of mass and serve as a mathematical model for the description of other phenomena.

Enduring Understanding	Learning Objectives
<p>6.E The direction of propagation of a wave such as light may be changed when the wave encounters an interface between two media.</p>	<p>6.E.5.1 The student is able to use quantitative and qualitative representations and models to analyze situations and solve problems about image formation occurring due to the refraction of light through thin lenses. (Science Practices 1.4 and 2.2)</p> <p>6.E.5.2 The student is able to plan data collection strategies, perform data analysis and evaluation of evidence, and refine scientific questions about the formation of images due to refraction for thin lenses. (Science Practices 4.1, 5.1, and 5.2)</p>

[NOTE: In addition to those listed in the learning objectives above, Science Practice 4.3 is also addressed in this investigation.]

Skills and Practices Taught/Emphasized in This Investigation

Science Practices	Activities
<p>1.4 The student can <i>use representations and models</i> to analyze situations or solve problems qualitatively and quantitatively.</p>	<p>Students use a ray diagram to locate the image for both a converging and diverging lens, indicating the correct refraction for each ray and accurately locating the image and identifying as real or virtual.</p>
<p>2.2 The student can <i>apply mathematical routines</i> to quantities that describe natural phenomena.</p>	<p>Students draw a best-fit line to the data and extrapolate to find the intercept, the reciprocal of which is the focal length.</p> <p>Students use the lens equation and a graph of their choosing to calculate the focal length of the converging lens.</p>

Science Practices	Activities
4.1 The student can <i>justify the selection of the kind of data</i> needed to answer a particular scientific question.	<p>Students justify the selection of the kind of data needed by:</p> <ul style="list-style-type: none"> • comparing the lens equation to their collected data to determine what to plot to get a straight line that can be used to determine the focal length • explaining why the distance from the object to the lens and from the image to the lens are measured. • explaining how the data collected will be plotted to answer the question being investigated
4.3 The student can <i>collect data</i> to answer a particular scientific question.	<p>Students accurately measure the image and object distances from the lens for real images formed by the converging lens.</p> <p>(Optional) Students use a converging lens in conjunction with a diverging lens to form a real image, and accurately measure the image and object distances for both lenses.</p>
5.1 The student can <i>analyze data</i> to identify patterns or relationships.	Students relate the information from the best-fit line to the graph and use that information to calculate the focal length of the converging lens.
5.2 The student can <i>refine observations and measurements</i> based on data analysis.	Students adjust the object position (independent variable) based on observations of the corresponding image positions in order to obtain data over as wide a range of positions as possible.

[NOTE: Students should be keeping artifacts (lab notebook, portfolio, etc.) that may be used as evidence when trying to get lab credit at some institutions.]

Equipment and Materials

Per lab group (two to four students):

- ▶ Light source such as a clear lamp with a filament or a candle (either wax or battery operated)
- ▶ Converging lenses, focal length 15–25 cm
- ▶ Lens holders
- ▶ Metersticks
- ▶ Index cards for screen (5×7 inches or larger)
- ▶ (Optional) Diverging lens

Timing and Length of Investigation

▶ **Teacher Preparation/Set-up:** 15 minutes

The set-up time depends on how long it will take you to retrieve the equipment from storage and make it available to the students.

▶ **Student Investigation:** 90 minutes

This time is for an introductory presentation of the question, and for your students to design the experiment and collect the data.

▶ **Extension (Diverging Lenses):** 60 minutes

This time is for students to work through a double-lens system to create a real image. They will need this much time to design their setup, make their measurements, and calculate the focal length of the diverging lens.

▶ **Postlab Discussion:** 45 minutes

The following day, you can engage students in a discussion of the precision and accuracy of their results. In particular, you can tell them the focal length specifications for each group's lenses, have them compute a percent difference, and then engage in a discussion about the sources of uncertainty.

▶ **Total Time:** 3.5 hours

Safety

If wax candles are used as a light source, be aware of the danger of students' hair or clothing catching fire. Students with long hair should pull it back and fasten it so it doesn't get near the candle. Students should secure any loose clothing (shawl, sweater, etc.) so it doesn't hang near the flame. Other than that, there are no safety concerns with this lab. General lab safety guidelines should always be observed.

Preparation and Prelab

This investigation should follow treatment of Snell's law and refraction. You can transition to convex lenses by having students consider how a ray is refracted at each surface of a converging lens. Demonstrate for students how a ray parallel to the principal axis is converged through the focal point. Inexpensive laser levels (or other laser pointers) can be used to create a bright ray that students can see as the ray is refracted through a piece of Plexiglas shaped like a converging lens. Several of these rays will converge to a focal point on the far side of the Plexiglas. Alternatively, if available, a Black Board Optics kit may be used or ray boxes that produce parallel rays, although these produce smaller effects and need to be used in smaller groups.

Give students instruction in ray tracing. Demonstrate ray tracing for students for a converging lens forming both a real image and a virtual image and for a diverging lens; then provide them the chance to practice on their own. You can refer them to “Lenses” (see Supplemental Resources), where they can move the object and see the corresponding location of the image for both kinds of lenses.

Next, either derive the lens equation for them from geometric principles and a ray diagram, assign them to read it from the text, or just simply present them with the equation and the conditions for its application. Students should be given several practice problems for homework in the application of the lens equation.

Once students are familiar with ray tracing and the lens equation and its use in problem solving, you can then present them with the question and the converging lens.

The Investigation

Each group designs an experiment to determine the focal length of a converging lens by taking measurements and creating a graph. Lenses with focal lengths between 15 cm and 25 cm work well. You can either provide students the equipment they need, or have them decide what they will need and ask for it. If they get stuck at this initial stage, ask them which equations they know that relate to focal length, and prompt them to explain that equation and all the terms in it. This should help them zero in on what they want to measure.

Students will hopefully decide to form real images with a light source and screen, and then measure the image distance and object distance. Ask them to identify what the independent variable and dependent variable are. Once they have done this, ask them to consider how to make multiple measurements of the dependent variable for each chosen value of the independent variable. You may need to suggest to them that each member of their team should independently locate the image and record the image distance for each object position. That way they will have several independent values of the dependent variable. They can then take the average of these values, and use them to determine the uncertainty in their measurements. The average of the image distance should be used for the graph. Students should make measurements of the dependent variable (image distance) for at least five different values of the independent variable.

Once students have completed the data collection portion of this lab, they should consider how to plot the data in order to determine the focal length. As discussed in the section on common student challenges, this is usually difficult for students and they may need significant guidance.

One approach is to graph the inverse of the image distance on the vertical axis and the inverse of the object distance on the horizontal axis. This should produce a straight line with a slope equal to -1 . The focal length can then be found as the inverse of the y -intercept. However, since the lens equation is symmetric with respect to object and image distance, students can reverse which quantities are plotted on each axis, and the inverse of the focal length will still be the intercept. In fact, it will be both the x -intercept and the y -intercept.

Another approach is to algebraically rearrange the lens equation and plot the product of the image distance and the object distance on the vertical axis, and the sum of the two on the horizontal axis. When plotted this way, the focal length is the slope of the graph.

$$\frac{1}{f} = \frac{1}{d_o} + \frac{1}{d_i}$$

$$\frac{1}{f} = \frac{d_i + d_o}{d_i d_o}$$

$$d_i d_o = f(d_i + d_o)$$

A third approach would be to have students plot the image distance versus the object distance and use the asymptotes to find the focal length. When the data is plotted this way, the graph is asymptotic both to the vertical line at $d_o = f$ and to the horizontal line $d_i = f$. If data of a great enough range is taken, these asymptotes will be easier to determine. However, this is not the most precise way to find the focal length, and students, after attempting this method, should be encouraged to consider one of the two previous methods.

Extension

Often there is one group of students that finishes far ahead of the other groups. You can ask this group to find the focal length of a diverging lens, which, by itself, only produces virtual images. Alternatively, you could ask all the students to consider how they could find the focal length of a diverging lens. To produce a real image, a system of two lenses, one converging and one diverging, is needed. Each group of students could determine the exact details of the how they would arrange two lenses to create a real image; the location and size of which can be measured and used to calculate the focal length of the diverging lens.

Typically, the simplest arrangement of lenses for this task is to place the object next to the diverging lens, a converging lens on the other side of the diverging lens, and the screen (where the real image will be focused) on the far side of the converging lens, as shown in Figure 1. The focal points of the diverging lens are labeled f , and the focal points of the converging lens are labeled f' . The virtual image formed by the diverging lens acts as the object for the converging lens. The final image distance is measured from the screen to the converging lens. Given the focal length of the converging lens, students can then calculate the location of the intermediate image formed by the diverging lens. This intermediate image is serving as the object for the converging lens.

Using the object distance (for the converging lens) and the distance between the lenses, the students can calculate the location of the intermediate image. Once the students know the location of the intermediate image formed by the diverging lens, they can use that, and the original object distance from the diverging lens, to calculate the focal length of the diverging lens.

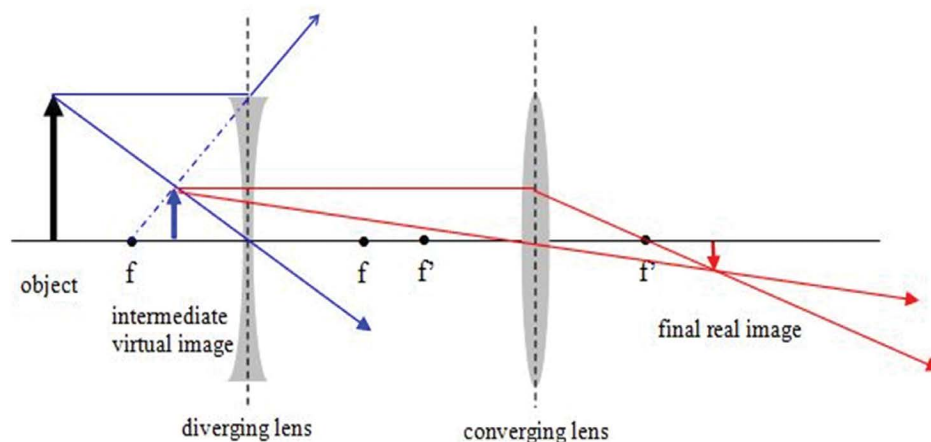

Figure 1

In drawing a ray diagram for a double-lens system, it is typical to simply address the image formation process by one lens at a time. In Figure 1, the rays shown in blue are refracted first by the diverging lens to form the intermediate virtual image. The rays that were traced to form this image are not useful for finding the final, real image. So the intermediate virtual image is used as the object for the converging lens. The rays shown in red, parallel to the principal axis and through the center of the converging lens, are drawn from the intermediate image to the converging lens, and shown as NOT refracted at the diverging lens. This is a convention used for the purpose of using the ray-tracing process with two lenses. In fact, those rays originate with the object (path not shown), strike the diverging lens at the location shown, and then follow the parallel or center paths (between the lenses) toward the converging lens.

It probably is not practical to repeat the process of drawing the graph, but students could be asked to move the lenses or the object until a different real image is formed and repeat the calculation to verify their first result.

Common Student Challenges

Students will probably easily understand that they need to use the lens to create an image, and then measure the object distance and the image distance. They may need to be reminded that when using the lens equation, these distances are measured from the lens, not from each other. They may also need to be encouraged to make sure that their image is well focused and sharp.

Students probably will also need to be reminded to measure the image distance several times and take an average. Students are not very good at taking multiple independent measurements, and thus will need to be reminded of techniques they can use to do this, such as having each group member take their own measurement of the image distance.

They might also have some difficulty determining what to plot on each axis of their graph and how to use it to determine the focal length. Each group should be allowed to struggle with this a bit, and you should refrain from having a whole-group discussion before the groups get a chance to plot their graphs. If they struggle, encourage each group to write out the equation relating image, distance, object distance, and focal length (i.e., the lens equation) and to write out the generic form of the equation for a straight line ($y = mx + b$). They should then be encouraged to consider what the dependent variable is, what the independent variable is, and make comparisons between the two equations.

Analyzing Results

If you decide to give students lenses all with the same focal length, you might want the groups to post their results on whiteboards to share in a class discussion. Or you can task each group (or individual) to prepare a formal written report of the procedure, diagrams (both of the physical set up used and ray tracing diagrams), data, and conclusions. The use of multiple representations (mathematical, graphical, and ray diagrams) helps reinforce the concepts that students are studying in this lab. Perhaps you will choose to have a class discussion and then have each group turn in a formal report with their results.

Students should be asked to compare their measured value of the focal length to the actual focal length of the lens (as specified by the manufacturer). If all students are given lenses of the same focal length, then they should be asked to compare their results to other groups' results and comment on which group's result was closest to the actual value. This comparison of the groups' various values should lead to a comparative discussion of the techniques used in measurements. Students should discuss what measurement techniques led to more precise and accurate measurements.

Next, lead them in a discussion of the uncertainty in their image distance measurement. Some guiding questions you could ask include:

- ▶ What was the measured uncertainty in the image distance?
- ▶ How much variation was there between the measurements made by each member of the group?
- ▶ What is the percent uncertainty in the image distance measurement?
- ▶ What is the percent uncertainty in the object distance measurement? (They may have to estimate this if they only measured it once.)
- ▶ Is the true value of their focal length (as specified by the manufacturer) within the range indicated by their uncertainties? In other words, if their image distance measurement has an uncertainty of 5 percent, is their measured value within 5 percent of the true value?
- ▶ What could be done to improve the precision of their measurements?
- ▶ How do the measurement uncertainties affect the value of the focal length? For example, if the image distances measured are all too small, what effect would that have on the calculation of the focal length?

If you want to further explore the behavior of lenses, you could introduce “Lens-Maker’s Formula” (see Supplemental Resources) and discuss how the manufacturer creates a lens of a specified focal length, and what the uncertainties are in this focal length.

Assessing Student Understanding

After completing this investigation, students should be able to:

- ▶ Articulate the difference between a virtual and a real image;
- ▶ Use a converging lens to form a real image;
- ▶ Articulate why they plotted the inverse of the image distance as a function of the inverse of the object distance, referring to the lens equation;
- ▶ Justify why the focal length is the inverse of the intercept; and
- ▶ Estimate the uncertainty in all measurements that were made several times.

Assessing the Science Practices

Some of the practices below need to be observed in a formative manner, as students are performing the measurements. For example, Science Practices 4.1 and 5.2 are best assessed while students are in the lab in a formative way rather than as summative assessments.

Science Practice 1.4 The student can *use representations and models* to analyze situations or solve problems qualitatively and quantitatively.

Proficient	Accurately draws a ray diagram to locate the image for both a converging and diverging lens, indicating the correct refraction for each ray and accurately locating the image; identifies when an image is real or virtual.
Nearly Proficient	Accurately draws a ray diagram for a converging lens but has difficulty with a diverging lens; accurately locates the image if it is real, but has difficulty ray tracing to find virtual images.
On the Path to Proficiency	Accurately draws the rays for a converging lens but does not accurately locate the image.
An Attempt	Draws an incomplete or incorrect ray diagram.

Science Practice 2.2 The student can *apply mathematical routines* to quantities that describe natural phenomena.

Proficient	Uses the lens equation to determine which quantities should be plotted to determine the focal length, and accurately calculates the focal length as the inverse of the intercept.
Nearly Proficient	Plots the inverses of the image and object distances, but uses the slope to calculate the focal length.
On the Path to Proficiency	Plots the image distance and the object distance, and uses a data point to calculate the focal length.
An Attempt	Plots an incomplete or incorrect graph.

Science Practice 4.1 The student can *justify the selection of the kind of data* needed to answer a particular scientific question.

Proficient	Explains why she/he is measuring the distance from the object to the lens and the image to the lens, and the justification is clear, easy to follow, and correct in terms of the lens equation; explains how the data will be plotted to answer the question and provides mathematical models that are justified; includes a discussion of assumptions inherent in each model and what to do to validate them.
Nearly Proficient	Explains why the inverse of the image and object distances are plotted, and knows to calculate the inverse of the slope, but there is no discussion of the assumptions inherent in the model.
On the Path to Proficiency	Describes that the image distance and object distance need to be measured, but does not articulate how to use them to calculate the focal length.
An Attempt	Cannot accurately measure the image or object distances.

Science Practice 4.3 The student can *collect data* to answer a particular scientific question.

Proficient	Accurately measures object distance and image distance for the converging lens; data spans an adequate range for both the independent and dependent variables; the student makes multiple measurements of each image distance and averages the values.
Nearly Proficient	Accurately measures image and object distance; the range of the data is too small or there are too few data points collected; or the student only made one measurement of each image distance.
On the Path to Proficiency	Measurements of the image distance and object distance are imprecise or inaccurate.
An Attempt	Cannot accurately measure the image distance from the screen to the lens.

Science Practice 5.1 The student can *analyze data* to identify patterns or relationships.

Proficient	Accurately plots the inverse of the image distance vs. the inverse of the object distance; draws a best-fit line to the data, and extrapolates the best-fit line until it intersects the axis; calculates the inverse of the intercept and reports this as the focal length.
Nearly Proficient	Accurately plots the inverse of the image distance vs. the inverse of the object distance, and draws a best-fit line; uses the slope to calculate the focal length.
On the Path to Proficiency	Plots the dependent variable vs. the independent variable, and draws a best-fit line to the data (which is not straight), but does not know how to calculate the focal length
An Attempt	Cannot use the image-distance and object-distance data to get a focal length.

Science Practice 5.2 The student can *refine observations and measurements* based on data analysis.

Proficient	Observes if data points seem to be inconsistent with the rest of the data set or do not lie near a best-fit line through the rest of the data; repeats any observations that seem to be inaccurate; accurately locates a clearly formed image; estimates the uncertainty in the object and image distance measurements, and explains how they impact the calculation of the focal length.
Nearly Proficient	Doesn't address wildly deviant data points in the drawing of the best-fit line; some of the images formed are slightly out of focus; estimates the uncertainties in the image and object distances, but is not clear on how they affect the focal length calculation.
On the Path to Proficiency	Cannot explain how to determine if data needs to be retaken or observations need to be refined; many of the images are slightly out of focus; cannot estimate the uncertainty in the image or object distance measurements.
An Attempt	Cannot adjust the position of the screen until a clear, crisp image is seen.

Supplemental Resources

“Geometric Optics 2.05.” PhET. University of Colorado Boulder. Accessed September 1, 2014. http://phet.colorado.edu/sims/geometric-optics/geometric-optics_en.html. [This simulation allows the students to move the object and show where the image location is. In addition, it allows them to change the refractive index of the material in the lens, and change the radius of curvature of the lens as well as the position of the object above or below the principal axis of the lens.]

“Lens-Maker’s Formula.” HyperPhysics. Georgia State University. Accessed September 1, 2014. <http://hyperphysics.phy-astr.gsu.edu/hbase/hph.html>.

“Lenses.” Northwestern University. Accessed September 1, 2014. <http://groups.physics.northwestern.edu/vpl/optics/lenses.html>. [*This Java applet allows the students to move the lens and the object and show the primary rays refracted through the lens (either converging or diverging) to form the image. Real images are shown in blue, and virtual images are shown in green.*]

Maley, Tim, Will Stoll, and Kadir Demir. “Seeing an Old Lab in a New Light: Transforming a Traditional Optics Lab into Full Guided Inquiry.” *The Physics Teacher* 51, no. 6 (2013): 368–371.

“The Physics of Optics.” Annenberg Learner. Video, 54:32. Accessed September 1, 2014. <http://www.learner.org/resources/series126.html>.

This page is intentionally left blank.

AP Physics 2 Investigation 7: The Particle Model of Light

What interactions of light and matter require a photon model of light for explanation?

Central Challenge

In this investigation, students use circuits with light-emitting diodes to gather evidence that supports the particle perspective of the interactions between light and matter. Students gain understanding of the necessity of a discrete model of the interaction between matter and radiation, the phenomena from which that necessity arose, and the experimental evidence supporting the model.

Background

Some properties of interactions between light and matter are better explained when light is described as a wave, and some properties of these interactions are better explained when light is described as a particle. Light-emitting diodes (LEDs) have become popular for experiments in which the photovoltaic effect can be used to develop evidence for the particle model of light (see “A Laboratory Investigation of Light-Emitting Diodes” in Supplemental Resources). The historical approach was to determine the maximum kinetic energy of an electron that was emitted from a conducting material upon the absorption of a photon by obtaining the measurement of the potential energy [as the product of] the fundamental charge of the electron and the electrical potential threshold at which current vanishes. Equivalent evidence supporting the particle model can be obtained by measuring the minimum potential at which photons are emitted from a semiconducting material and current appears. From both perspectives, explanation of the process requires a model of discrete events whose energies are proportional to the frequency of light absorbed or emitted ($E_{\text{photon}} = hf$).

Photons are individual energy packets of electromagnetic waves, with $E_{\text{photon}} = hf$, where h is Planck’s constant and f is the frequency of the photon. Evidence for discrete energy packets is provided by a frequency threshold for electron emission due to the photoelectric effect. The threshold frequency (f_0) provides the minimum amount of energy necessary to free electrons from a solid to a point immediately outside the solid. This minimum amount of energy is called the work function (ϕ). When a material with work function (ϕ) absorbs photons of energy (hf), the energy above this threshold ($hf - \phi$) is the maximum kinetic energy the emitted electrons can have (K_{max}). Above the threshold, emission (i.e., the number of electrons freed) increases with the intensity of the incident radiation (since intensity is proportional to the number of photons). The photoelectric effect is described with energy conservation during the process of photon absorption ($E_{\text{photon}} = hf = \phi + K_{\text{max}}$).

Since ϕ is the minimum amount of energy necessary to free an electron, $E_{\text{photon}} - \phi$ represents the most kinetic energy an electron can gain. If more energy is required to free it, it would have less kinetic energy. At the threshold frequency (f_0), the lowest frequency that can result in electron emission, the photon energy is equal to the work function ($E_{\text{photon}} = hf_0 = \phi$).

Electric potential energies in semiconductors have a gap between a ground state referred to as the valence band and a higher energy state called the conduction band. The work done by an external electric potential can excite electrons over this energy gap (E_g). In the photovoltaic effect, when an electron returns to the ground state, radiant energy is emitted ($E_{\text{photon}} = hf_0 = \phi_g$).

The common use of conservation of energy and the types of energy involved in the photoelectric and photovoltaic effects are used in this set of activities to explore interactions between light and matter and develop an understanding of the photoelectric effect. These comparisons are somewhat oversimplified but reasonable at an introductory level.

Real-World Applications

The photoelectric effect occurs in situations where radiation striking materials causes those materials to emit electrons, leaving the materials with a net positive charge. Spacecraft exposed to intense solar radiation may develop a net positive charge on their solar side by the same mechanism. The opposite side of the craft may develop a negative charge due to exposure to plasma, leading to the possibility of an electrical discharge from one side to the other — or through the craft — potentially causing damage to delicate instruments inside the spacecraft (see Shu T. Lai's book in Supplemental Resources).

Night vision goggles use the photoelectric effect to amplify images in dim light. As photons hit a semiconducting material, electrons are emitted and directed by an electric field into a photoamplifier.

Photovoltaic devices are benefiting human society and promise even greater improvements in the future. Solar panels apply the photovoltaic effect to generate power, helping to reduce atmospheric carbon pollutants. Local power generation and storage using photovoltaics may someday help relieve high energy demand in urban centers and provide a sustainable technology for personal transportation.

Inquiry Overview

In this two-part investigation, inquiry-based instruction takes place through the integration of group discussions with student-run data collection and analysis activities. In Part I, an engagement phase is used to demonstrate the particle perspective based on observations of the photoelectric effect. Then, in Part II, a student-directed investigation involving LEDs provides an opportunity for data collection using the photovoltaic effect that leads students to an understanding of the relationship between photon energy and frequency. The suggested extension provides a more advanced activity that increases the precision of the measurement of the threshold electric potential.

In Part I of the investigation, a series of interactive demonstrations enables you to engage students in a conversation that will help them develop concepts related to the photoelectric effect. Students then work in small groups to process this information and use it to develop a plan for the investigation. In Part II, groups of students build a circuit using inexpensive components to observe, gather data, and graph the data relating energy of electrons to frequency of light. Analysis of the data will lead students to develop their written and verbal discussions that support the particle model of light.

The students' role in data collection depends on the choice of instrumentation. Using simple methods and common lab equipment (as described in the Investigation section), students can setup their own circuit to measure the threshold potential difference across the LEDs. Students can then observe the threshold potential by adjusting the current supplied by a battery using a potentiometer (or by a variable DC power supply) while measuring the potential difference across the LED with a multimeter. Using an expensive commercial apparatus (such as a photovoltaic measurement kit) will likely produce better results, but will involve students less in the design of the circuit to setup the experiment. The advantage of having students setup their own circuit is that it provides an opportunity for students to review what they have learned about circuit components and circuit connections, and to take a larger role in deciding how to make those connections (e.g., remembering to connect the voltmeter in parallel across each LED).

Connection to the AP Physics 2 Curriculum Framework

Big Idea 5 Changes that occur as a result of interactions are constrained by conservation laws.

Enduring Understanding	Learning Objectives
5.B The energy of a system is conserved.	5.B.8.1 The student is able to describe emission or absorption spectra associated with electronic or nuclear transitions as transitions between allowed energy states of the atom in terms of the principle of energy conservation, including characterization of the frequency of radiation emitted or absorbed. (Science Practice 1.2)

Big Idea 6 Waves can transfer energy and momentum from one location to another without the permanent transfer of mass and serve as a mathematical model for the description of other phenomena.

Enduring Understanding	Learning Objectives
6.F Electromagnetic radiation can be modeled as waves or as fundamental particles.	6.F.3.1 The student is able to support the photon model of radiant energy with evidence provided by the photoelectric effect. (Science Practice 6.4)
	6.F.4.1 The student is able to select a model of radiant energy that is appropriate to the spatial or temporal scale of an interaction with matter. (Science Practices 6.4 and 7.1)

[NOTE: In addition to those listed in the learning objectives above, Science Practices 1.4, 3.2, 4.2, 4.3, 5.1, and 6.2 are also addressed in this investigation.]

Skills and Practices Taught/Emphasized in This Investigation

Science Practices	Activities
1.1 The student can <i>create representations and models</i> of natural or man-made phenomena and systems in the domain.	Students reason from observations to construct a model of the interaction between light and a conductor in contact with an electroscope, which they will discuss in their lab report and in the postlab presentations. They construct energy diagrams to describe the electron energies during the formative assessment.
1.2 The student can <i>describe representations and models</i> of natural or man-made phenomena and systems in the domain.	Students describe the interaction between light and the electrons in a metal in contact with the electroscope using energy diagrams. They also use a circuit schematic diagram to setup a circuit and describe how potential difference will be measured for the LEDs.
1.4 The student can <i>use representations and models</i> to analyze situations or solve problems qualitatively and quantitatively.	Students use energy diagrams to analyze the behavior of photoelectric and photovoltaic processes.
3.2 The student can <i>refine scientific questions</i> .	Students refine a broad question concerning the interaction of light with electrons by considering the difference between the behaviors of positively and negatively charged electroscopes illuminated by mercury-vapor lamps.
4.2 The student can <i>design a plan</i> for collecting data to answer a particular scientific question.	Students design a test of their claim that a positively charged electroscope will not behave in a manner that is consistent with the removal of electrons.
4.3 The student can <i>collect data</i> to answer a particular scientific question.	Students construct a circuit and use that circuit to collect data on the threshold potential difference of LEDs.

Science Practices	Activities
5.1 The student can <i>analyze data</i> to identify patterns or relationships.	Students identify a pattern of increasing threshold potentials with increasing wavelength, both by observation and by graphical analysis of data.
6.2 The student can <i>construct explanations of phenomena based on evidence</i> produced through scientific practices.	Students construct a particle-based model of light that incorporates the particle and use it to explain their observations.
6.4 The student can <i>make claims and predictions about natural phenomena</i> based on scientific theories and models.	Students develop a model based on data and the application of the principle of energy conservation. Students then apply a particle model of light to predict system behavior and support their prediction using evidence obtained from a demonstration in which an electric current is generated by the interaction between light and a conductor.
7.1 The student can <i>connect phenomena and models</i> across spatial and temporal scales.	Students differentiate the models of light used to explain diffraction and the photoelectric effect, summarizing the essential evidence supporting each model.

[NOTE: Students should be keeping artifacts (lab notebook, portfolio, etc.) that may be used as evidence when trying to get lab credit at some institutions.]

Equipment and Materials

Part I: Demonstration of Photoelectric Effect

- ▶ Electroscope (with a conducting surface on which metals can be placed)
- ▶ Plastic rod or cylinder, such as a disposable pen or a piece of PVC pipe
- ▶ Glass rod
- ▶ Metal plates (zinc, copper, and steel) and steel wool
- ▶ Mercury-vapor lamp or ultraviolet light source (The lamp must emit UV-light below 280 nm, the threshold set by the work function of copper metal. Some UV lamps may emit only UV-b and UV-a wavelengths and so cannot be used. These include fluorescent tubes used in tanning beds and black lights. Lamps that are described as *germicidal* will work.)
- ▶ Emery cloth
- ▶ Fur, felt, or wool cloth to transfer negative charge to the plastic rod or cylinder
- ▶ Silk or equivalent material to transfer negative charge from the glass rod

Part II: Student Investigation of Photovoltaic Effect*For prelab discussion:*

- ▶ Power supply with variable potential difference or battery with potentiometer
- ▶ Small incandescent bulb with base

Per lab group (three to four students):

- ▶ Light-emitting diodes (red, green, and blue), available from science supply catalogs or electronics supply stores
- ▶ 2–6 volt variable DC power supply or a battery pack with three or four C or D cells
- ▶ Alligator clips and jumper wires
- ▶ Potentiometer or trimpot (to use with batteries to vary potential difference if a variable DC power supply is not used)
- ▶ Multimeter
- ▶ (Optional) Breadboard (connections can be made directly without it, if preferred)
- ▶ (Optional) Cardboard tube from an empty paper towel roll to reduce ambient light while taking readings for LED
- ▶ (Optional) Several small resistors (330–660 ohms), as needed, to reduce current in the circuit when a power supply is used
- ▶ (Optional) Photovoltaic measurement kits, available from many online sources

Timing and Length of Investigation

- ▶ **Teacher Preparation/Set-up:** 15–20 minutes

This time is needed to prepare the demos and set out whiteboards and equipment.

- ▶ **Demonstration (Part I):** 45–60 minutes

Engagement phase: 15–20 minutes

Model building, small and large group discussions: 30–40 minutes

- ▶ **Student Investigation (Part II):** 45–60 minutes
- ▶ **Postlab Discussion:** 30 minutes
- ▶ **Total Time:** approximately 2.5–3 hours

Safety

In Part I, a mercury-vapor lamp (or other UV source) is used, if available, for the demonstration. The lamp must be uncoated so that ultraviolet light is emitted. Great caution should be taken when using the mercury-vapor lamp (or any ultraviolet source) to minimize students' exposure. Students should wear safety goggles that can protect against UV damage to the eyes, and be advised to avoid looking directly into the UV source.

If variable DC power supplies are used in Part II, students should have experience with these or be provided with instruction in safe and proper use. There is little safety concern if batteries are used instead.

There are no specific safety concerns for this lab beyond what has been articulated above. General lab safety guidelines should always be observed.

Preparation and Prelab

A formative assessment should be given to students to assess readiness, and to provide you information that you can subsequently refer to in the development of a particle model of light. The entire formative assessment and small-group discussion may require one class period to complete.

The first two questions of the formative assessment address the essential features of the potential difference in terms of familiar representations of the photoelectric effect and energy conservation. Recent research on the use of multiple representations of energy is applied in many simulations on the PhET website (see Supplementary Resources for two examples).

The third question reminds students that a wave model of light is necessary to describe diffraction, and the last three questions address the essential features from which students will be asked to construct the particle model of light and contrast it with the wave model.

Formative Assessment

Ask students to respond to the following prompts:

1. Describe in terms of an energy diagram the forms of energy of a charged particle in an electric field.
2. Use a diagram to describe the energy of an electron injected into the space between two charged plates.
3. Represent with a sketch how, due to wave interference, light from a laser striking a pair of slits leads to the formation of maxima and minima in the intensity of light on a distant screen.

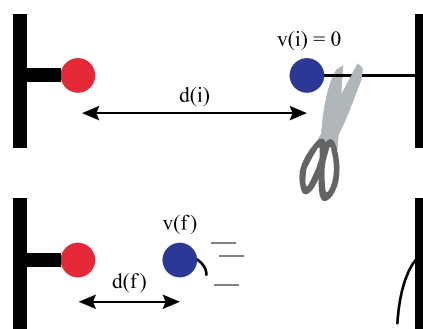

Figure 1

4. In Figure 1 a small ball with a positive charge is strongly attracted to another ball with a negative charge and a mass (m). The positively charged ball is fixed on the end of an insulating rod. The negatively charged ball is attached to an insulating thread. The thread is cut. Describe changes in electric potential energy, kinetic energy, and total energy when the thread is cut using an energy diagram with at least three states: before the thread is cut, after the thread is cut but before the balls collide, and just before the balls collide.
5. An electric potential difference ΔV is used to accelerate an electron through a small opening in a positively charged plate. The electron is shot through the opening into a space between this plate and a second, parallel plate that is oppositely charged. Draw a picture of the system. Using two energy diagrams, describe changes in potential, kinetic, and total energy of the electron when (a) $K_{\text{initial}} < e\Delta V$ and (b) when $K_{\text{initial}} > e\Delta V$. As one state in your energy diagram, consider the moment when the electron just emerges from the small opening. If there is a time when the kinetic energy of the electron vanishes, include that state in your energy diagram. If the electron arrives at the second, negatively charged plate, include that moment as a state in your energy diagram.

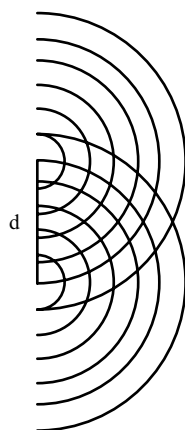

Figure 2

6. Light from a laser strikes two slits separated by a distance that is small but larger than the wavelength of the light. Using the diagram in Figure 2, identify interactions leading to at least five bright spots that appear on a screen across the room.

The Investigation

Part I: Demonstration of Photoelectric Effect

The teacher demonstration performed in this section is used to develop concepts in readiness for students to design an experiment in Part II. In a large class an overhead projector or USB camera should be used to allow all students to participate. It's best if you take a Socratic approach — asking questions at key points and allowing students to think about their responses before answering. Occasionally, give students 2 minutes or so to discuss their answers with a partner; then randomly select students to give their answers.

Stroke a plastic cylinder with fur, wool cloth, or felt and use it to charge an electroscope with negative charge, causing the leaves to spread apart. Direct light from a mercury-vapor lamp onto a plate contacting the leaves so the spread of the leaves decays slowly. Place a sheet of zinc on the plate to repeat the charging process. When the lamp shines on the zinc sheet, the repulsion between the leaves decays completely in just a few seconds. Students have likely observed repulsion in the electroscope during their study of electrostatics and with a few prompts are able to recall that this repulsion can be explained in terms of the distribution and interactions of electrons. [NOTE: If students have not observed the charging of an electroscope, this should be a prerequisite activity or should be researched in a textbook or online.]

The ability to construct an explanation is a skill this lesson is intended to support. Elicit the following initiating question from the class: “Why does the light cause the rearrangement of electrons in the electroscope?” When the question has been posed by a student, involve others in the evaluation of the quality of the question. If students do not pose this question, pause to review earlier experiences with charged objects and electroscopes. It is important that students feel ownership of the development of the model toward which this instructional sequence is directed. [NOTE: It is *not* the intention here that students actually use the ultraviolet light or mercury-vapor lamp to do the follow-up investigations. At all times, you perform the actual operations proposed by students, with appropriate caution for use of the ultraviolet light or mercury-vapor lamp.]

Students will shortly come to a consensus that the energy of the light is somehow responsible. This is an opportunity to replace *energy* with *intensity*. A rationale for identifying intensity as opposed to energy as an initial composing element of the model is that their model should be based on observable evidence. Confirm their thinking by grounding the electroscope and decreasing the intensity by raising the lamp a few centimeters. The decay is much slower.

The lamp has only a small effect when held about 20 cm above the plate. By lowering and then raising the lamp, students will be able to observe oscillations in the leaves that are induced by changes in the distance between the lamp and the plate. The intensity of light from the mercury-vapor lamp is confirmed as a factor. However, shining an intense halogen flashlight on the zinc plate can then be shown to have no effect.

Substitute other metals for zinc and repeat the process. The work function for zinc is small. When zinc is replaced with sheets of steel and copper, the decay of the repulsion between the leaves is much slower. In each case, an emery cloth should be used to remove any corrosion on the metal that might limit conduction at the surfaces of the metals. You might want to ask students to consider how the contact between the metal surfaces affects the experiment. Further investigation into the role of contact between the metal plate and the electroscope surface can be pursued by using a wad of coarse steel wool instead of a metal plate on top of the electroscope. The decay of the repulsion between the leaves is slower when the shape of a wad of steel wool is varied to change the area of contacting surfaces between the electroscope and the steel wool. When the wool is flattened on the surface, the decay of the repulsion occurs more quickly. Guide students towards the conjecture that electrons are being removed from the electroscope through a process involving the interaction of light and metal.

Now have students work in small groups to revise the vague question, “How can we know if the light is having an effect on electrons?” The goal is to have students refine this question into the testable question, “How can evidence be obtained supporting the conclusion that what you are seeing when light from the mercury-vapor lamp shines on the metal involves electrons being removed from the electroscope?”

Visit the groups and gradually, as necessary, remind them that electroscopes can also be positively charged by using a glass rod that has been rubbed with a silk cloth. Each group should make a claim for which they design a method of testing how the electroscope could be positively charged. When the groups have arrived at a testable question, their task is to develop a strategy to evaluate the question. Share with them the rubrics for this task (see the rubric for SP 3.2 and 4.2 in the Assessing the Science Practices section).

Questioning can guide students toward the idea that if the leaves of a positively charged electroscope become less repulsive or are not affected, evidence is provided that electrons are being removed from the metal. Positive charging is often more difficult to produce than negative charging. [NOTE: If this activity is done when humidity is high, a hair dryer can be used to gently dry out the apparatus prior to the demonstration.] Perform the experiment for positive charging as a demonstration for the class, using methods suggested by student groups or using what you have readily available, and verbally reinforcing other successful methods suggested by groups.

This is a good point to begin the development of a model as a whole-class discussion. Ask students to recall the sequence of questions on the formative assessment. Ask them to describe a situation in which an electron that is released into the space between two oppositely charged plates stops moving towards the repulsive plate in terms of the energy diagram. Guide them to define the initial state where the electron emerges from the hole and the final state as the point at which the electron stops. Help them to recall that as the electron is slowed by the field between the plates, work is done on the electron by the field. The sign of the work is negative because energy is being removed from the electron. Ask them to confirm the sign of the quantity $e\Delta V$ by setting the electric potential at the positively charged plate equal to zero and by identifying the direction of the electric field.

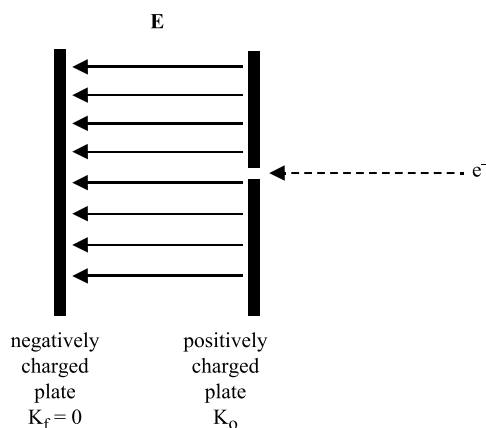

Figure 3

In this way the discussion is guided toward the role of light from the mercury-vapor lamp in doing work on electrons in the zinc plate. Guide discussion with the following questions: "If electrons are being removed from the electroscope, is the work done on the electrons positive or negative? If the electrons in the metal are initially at rest, what change in the system does work produce?"

Have students work in small groups to construct an energy diagram to answer the question, using whiteboards to construct the representation. (See the rubric for SP 6.4 in the Assessing the Science Practices section.)

Part II: Student Investigation of the Relationships between Electron Energy and Light Frequency in a Circuit

The focus now shifts towards the dependence of electron energy on frequency. The learning objective is the ability to construct explanations, so it is your responsibility to support students' construction. A good place to start this segment of the model development is to return to the demonstration apparatus and compare the effects of the bright halogen flashlight and the not very bright mercury-vapor lamp. To segue to data collection, use the idea that the energy of electrons removed from the zinc sheet can't be measured with the demonstration device and that a better detection device than the electroscope is needed. You might want to demonstrate first that increasing the potential difference in a simple circuit with an incandescent light bulb will cause the bulb to shine at a certain point; below a certain potential difference, the bulb won't shine.

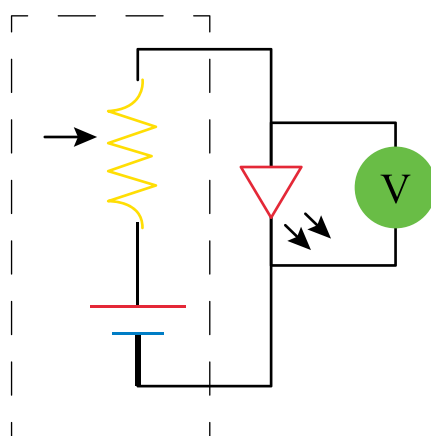

Variable DC power supply
or batteries with a potentiometer

Figure 4: Schematic LED circuit

Data Collection

Sketch the circuit on the board as shown in Figure 4, consisting of a battery, a potentiometer (variable resistor), and an LED. The circuit could also consist of a variable DC power supply, a small resistor to reduce current, and an LED.

[NOTE: If the power supply goes to zero, which some do, the resistor isn't even necessary except to keep the current low enough to prevent burning out the LEDs.] Whatever is used, the idea is to be able to provide a potential difference to each LED so that the LED can be turned off and on without burning it out.

Remind students that LEDs have polarity with the shorter lead closest to ground and the longer lead connected to the higher potential side of the battery or power supply. [NOTE: Though semiconductors are not part of the curriculum, students are often curious about how LEDs work, since they are common now in everyday usage. You might want to encourage students to pursue their own research on LEDs — either to append to their laboratory analysis or to satisfy their own curiosity. The mechanism of how LEDs work, however, is not part of this investigation.]

By adjusting the electric potential difference across the LED using either a variable voltage power supply or a potentiometer, students can use the reading on the voltmeter to record the minimum electric potential difference at which the LED emits light. A section of PVC pipe or cardboard tube placed over the LED in a darkened room during the determination of when the bulb is at its shutoff point will eliminate bias due to the ambient light. Encourage the groups to achieve precision with at least three measurements made by different group members.

Provide information about the wavelength of each LED color to students. (This can be acquired by referring to markings on the package for the LED or by doing an online search for “LED wavelengths.”) Although the method of measurement is prescribed, students can play a role in the experimental design by constructing a data table in which the entire class may record their observations. In this way, each group has access to a large data set for analysis.

To compare the reproducibility of the measured threshold potentials among the three LED colors, students should record their data and compare with the class data. The red light will probably show the greatest variability and the blue light the least. [NOTE: The package markings for LED wavelengths are probably accurate, but many LEDs have a small bandwidth around the average. This introduces a systematic error into the investigation.]

Students may choose to do a cross-check of LED wavelengths by performing a diffraction experiment with each LED to determine wavelength. This will depend upon the motivation and skill of each group. One such procedure is described in the University of Wisconsin-Madison’s LED diffraction lesson (see Supplemental Resources).

After a group has completed their measurements, ask them to contrast their observations with the process observed for the mercury-vapor lamp. Guiding questions such as the following can be provided to motivate further analysis by students:

- ▶ In which of these systems is light absorbed and in which is light emitted?
- ▶ What work is done on the electrons in the electroscope by the mercury-vapor lamp, and what are the consequences?
- ▶ What work is done on the electrons in the circuit by the power supply, and what are the consequences?

Ask each group to whiteboard their description and support it with an energy diagram. You can then confirm the accuracy and thoroughness of the representations, using the rubric provided (see the rubric for SP 1.4 in the Assessing the Science Practices section). When the group has identified the measurement of the potential difference at which the LED shines, it is referred to as the *threshold potential*.

Extensions

If students have had previous experience in recording measurements with uncertainties or graphing with error bars, the experiment in Part II lends itself well to that statistical examination. However, it is not included as part of the main experiment description as it is assumed that the experiment in Part II has enough challenges for most students; introducing uncertainties at this point may be overwhelming for many.

Students can extend the work in Part II and significantly increase the precision of their measurements of Planck's constant by constructing a spectrometer with materials that cost just a few dollars. Several open source projects for this extension are listed in the Supplementary Resources (see, for example, "Spectrometer"). With some inexpensive components, an op-amp circuit can be used to boost the sensitivity of a photodiode circuit that captures the output of the LED. This extension is also described at a link found in Supplementary Resources: "DIY Science: Measuring Light with a Photodiode II."

As an additional challenge, if time permits, ask students to review the article by Planinšič and Etkina that's listed in the Supplemental Resources. Challenge them to try one of the simple activities described there, using their LED circuit from Part II. For example, they can use the circuit to show that shining a laser directly onto an LED at the threshold potential difference produces a small current in the circuit. The challenge would be for students to make a claim about the phenomenon, try it, and then support the claim with their observations and research from the article.

Common Student Challenges

Typically, until now most students have constructed and analyzed circuits consisting only of capacitors and resistors. The following properties of an LED should be presented to students:

- ▶ They are directional and need to be connected with the long post to the positive.
- ▶ They easily burn out if used in a circuit with little or no resistance.
- ▶ They convert electrical potential energy into radiant energy.

Many students only slowly develop the ability to translate a schematic into a physical circuit. It is important that students who struggle are in groups that are small enough that they are active participants. Components and contacts can fail. Give students troubleshooting skills such as the continuity and diode tester on their multimeter, but don't solve their problem for them. It is a good idea to have a clone of the circuit they are building in the room that they can refer to as an example.

It may be difficult for students to grasp the significance of the photoelectric effect and its unexpected dependence on the intensity of light. Frequent questioning regarding the accumulation of energy below the threshold frequency can help them to understand just how surprising these discoveries were. (Several references in Supplemental Resources, including the one by Knight, can provide further information regarding energy below the threshold frequency, if needed.)

There are two common practical challenges in this inquiry. First, many students cannot manipulate exponents in scientific notation and the larger the exponent value the greater the difficulty. Second, if students perceive measurement as the determination of points rather than intervals they may conclude either that the measurements did not work or that Planck's constant is undefined. Both of these technical challenges are best addressed by a consistent expectation for the use of scientific notation and an understanding that measurements have accompanying uncertainty.

Analyzing Results

Ask the students to look for a pattern in their measured potential differences for the LED, and report that pattern with a sketch of a graph using whiteboard, large poster paper, or projection from a computer (see the rubric for SP 5.1 in the Assessing the Science Practices section.) The graphs will show that as the wavelength decreases the potential difference of the LED for LEDs of that wavelength increases. When this dependence is revealed, ask students in their lab groups to consider the question, "Why does the brightness of the LED increase as the electric potential difference increases beyond the threshold potential?"

The goal of this question is to arrive at an apparent contradiction — light intensity continuously increases with potential difference above the threshold frequency but not below. If intensity could accumulate, wouldn't enough light below the threshold lead to some current? The student groups should report out their ideas using whiteboards. A rubric for this assessment is provided (see the rubric for SP 6.2 in the Assessing the Science Practices section.).

The next point to reach for can be expressed with the question, "Why does the LED have a threshold potential?" It is useful to redirect the discussion to photoelectron emission from a metal and the demonstration of Part I.

When groups have reported on their representations using whiteboards, introduce the term *stopping potential*. The goal is to lead them to the idea that there is current only when the kinetic energy (K) of an electron emitted from the metal surface is greater than the potential energy difference ($e\Delta V$) between the plates.

If the model does not emerge among students, the PhET “Photoelectric Effect” simulation (see Supplemental Resources) would be an appropriate activity here to support development of students’ conceptual understanding. In a class with sufficient computer resources, students can be guided to explore and rediscover the wavelength dependence already observed in their earlier measurements. Ask, “What properties of the system initiate the emission of electrons from the zinc plate?” If computer resources are not available, the app can be projected for a whole-class discussion.

The representation of the photoelectric effect is again contrasted with the threshold potential observed in this experiment with LEDs (always emphasizing to students that this is not the photoelectric effect but a model that supports similar basic concepts — a “reverse photoelectric” of sorts.) In the photoelectric effect in Part I, the work function can be thought of as the charge of the electron times the potential difference between the bound state and the free state for the electron. Using $e\Delta V$ instead of ϕ to represent this amount of energy, the maximum kinetic energy of the electron freed by the energy provided by the radiant energy of a light source is:

$$K = E_{light} - e\Delta V \quad \text{photoelectric effect}$$

In the lab with LEDs in Part II, the potential difference over the light source causing the emission of radiant energy is:

$$e\Delta V = E_{light} - eV_{threshold} \quad \text{photovoltaic effect}$$

Suggest this relationship when visiting the small groups. They should now be able to plot the threshold electric potential difference against the frequencies of the light emitted by the LEDs. The slopes of these graphs will be h/e , where h is the constant of proportionality in their model of the energy of light. These slopes typically differ by about 20 percent but encompass an accepted value.

Characteristic student measurements illustrate the quality of data that can be expected from measurements of the threshold potential as described here. In the figure at the top of the next page, a commercially available device gives an acceptably accurate result. The regression line gives a value of Planck’s constant of 6.1×10^{-34} J-s.

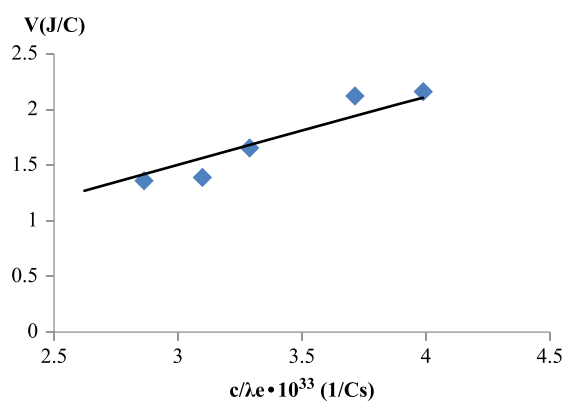

Figure 5

Students may also choose to plot energy as a function of frequency. The energy is calculated by multiplying the measured threshold potential difference across the LED by the charge of each electron, (eV , in joules). The LED frequency is calculated using an average reported value for LED wavelength (c/λ , in hertz; see Figure 6). The LEDs used for the graph below were purchased from a local electronics store, and plotted data values are from readings of threshold potential differences for four different LED colors supplied by 26 different students. In this more direct method of graphing, the experimental value for Planck's constant is simply the slope of the graph, determined here using a spreadsheet graphing program to be 6.0×10^{-34} J-s. Using more LED colors (in this case red, orange, yellow, and green, respectively) and accumulating data from the entire class gives students a better idea of the spread of data and the sense of using larger numbers of data points. [NOTE: The values for wavelengths used for this data were 535 nm for green, 580 nm for yellow, 600 nm for orange, and 685 nm for red.]

Caution students to be careful about reaching conclusions from mere observation of the sample graph here (obtained from actual student data), since many of the data points cluster on top of each other. This sample was derived from 92 data points, using the Excel graphing program to calculate the slope uses all the data points. Averaging from separate calculation of the 92 data points, using $E_{\text{photon}} = hf$ is much less desirable.

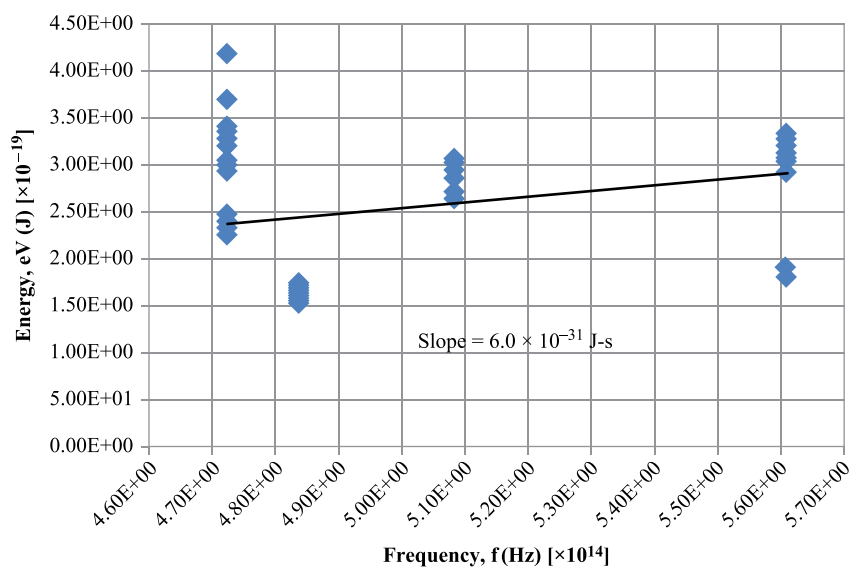

Figure 6: Sample Student Graph

[NOTE: It may be pointed out to your more advanced students that extension of the graph line by rescaling the x -axis so the line extends to the intercepts on both axes (shown below) provides interesting results. The graph line should go through a positive frequency intercept that represents the threshold frequency, assuming a common value for these LEDs. The line will also have a negative y -axis or energy intercept representing the work function, assuming a common value for these LEDs. It is often the case that the various colors of LEDs used in the experiment are made of the same metal base, hence they all can be assumed to have the same work function. The color variations come from “doping” the metal. Further research on this topic might be interesting to both you and your students.]

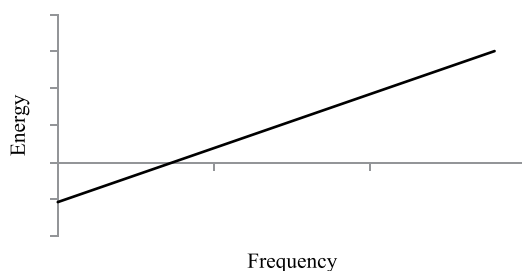

Figure 7

Post-Inquiry Discussion and Assessment

The observations made during the first demonstrations (Part I) should now be revisited and each explained by student groups using whiteboards and an explicit rubric (see the rubric for SP 6.4 in the Assessing the Science Practices section). Ask students the following questions:

- ▶ Why did the halogen flashlight, which was apparently more intense than the mercury-vapor lamp, not affect the electroscope leaves?
- ▶ Why did increasing the distance of the metal surface from the mercury-vapor lamp slow down the decay of the repulsion between the leaves?
- ▶ Why do different metals show different rates of decay?
- ▶ Why does rate of decay depend on the shape of the steel wool?

Now ask students to return to the formative assessment (see the rubric for SP 7.1 in the Assessing the Science Practices section). They should briefly describe:

- ▶ What are the features of the model of light that explain diffraction? Contrast these with features of the model of light that explain the photoelectric effect.
- ▶ What are the features of the inappropriate model that are inconsistent with the behavior of light (a) when diffracted and (b) when causing the emission of an electron from a conducting surface?

Assessing Student Understanding

After completing this investigation, students should be able to:

- ▶ Articulate the features of the photoelectric effect that necessitate a particle model of light;
- ▶ Explain the similarities of the photoelectric and photovoltaic effects in terms of the conservation of energy; and
- ▶ Express the relationship between the energy and frequency of a photon and the evidence supporting the validity of that model.

Assessing the Science Practices

Science Practice 1.1 The student can *create representations and models* of natural or man-made phenomena and systems in the domain.

Proficient	Draws energy diagrams with annotations; kinetic and potential energy are shown correctly; and connections made to arrangement of electrons and to the question.
Nearly Proficient	Draws energy diagrams that include annotations with kinetic and potential energies and a connection made to the arrangement of electrons.
On the Path to Proficiency	Draws energy diagrams that include annotations with connections made to the arrangement of electrons, but kinetic and potential energy are shown incorrectly.
An Attempt	Draws energy diagrams with no annotations; the kinetic and potential energy are shown incorrectly; and no connections are made to the arrangement of electrons.

Science Practice 1.4 The student can *use representations and models* to analyze situations or solve problems qualitatively and quantitatively.

Proficient	Draws energy diagrams with clear connections between both processes with essential features of both processes and clear, accurate representations of forms of energy. Describes differences between the behaviors of the electroscope and LED systems. Uses descriptions and qualitative representations (both calculations and graphs) correctly to show the relationship between photon energy and frequency/wavelength.
Nearly Proficient	Draws energy diagrams with clear connections between both processes with essential features of both processes and clear, accurate representations of forms of energy; the qualitative/quantitative work relating photon energy to frequency contains several errors.
On the Path to Proficiency	Draws energy diagrams with many essential features of both processes and connections between the two processes, but representations of forms of energy are not clear or contain errors; attempts qualitative/quantitative representations that are not correct.
An Attempt	Draws energy diagrams with some essential features of both processes but connections between the two processes are not made clear; representations of forms of energy are incorrectly shown; does not include qualitative representations from Part II of the investigation.

Science Practice 1.5 The student can *re-express key elements of natural phenomena across multiple representations* in the domain.

Proficient	Presents energy drawings that are complete and correctly identify the processes and energy. Constructs a graph of data from Part II of the investigation that shows the relationship between frequency and photo energy.
Nearly Proficient	Presents energy drawings and a graph from Part II of the investigation but does not correctly identify all of the processes or energy states.
On the Path to Proficiency	Presents energy drawings but does not correctly identify the processes or energy states. Attempts a graph for Part II of the investigation but does not correctly show energy and frequency relationships for the LEDs.
An Attempt	Presents energy drawings but does not identify the processes or energy states; unable to construct a graph from Part II of the investigation.

Science Practice 3.2 The student can *refine scientific questions*.

Proficient	Restates the initial question from Part I of the investigation by incorporating relevant features of charged particles and the properties of the electroscope, and states a refined question that identifies features that can be manipulated, including a method of testing the question.
Nearly Proficient	Restates the initial question from Part I of the investigation by incorporating relevant features of charged particles and the properties of the electroscope, and states a refined question that identifies features that can be manipulated.
On the Path to Proficiency	Restates the initial question from Part I of the investigation by incorporating relevant features of charged particles and the properties of the electroscope.
An Attempt	Restates the initial question from Part I of the investigation without identifying relevant features of electrons and the electroscope.

Science Practice 4.2 The student can *design a plan* for collecting data to answer a particular scientific question.

Proficient	Clearly restates the question, and proposes measurements to be taken to evaluate how frequency/wavelength and energy are related. Makes clear connections between evidence obtained from measurement and the question.
Nearly Proficient	Clearly restates the question, and proposes measurements to be taken to evaluate how frequency/wavelength and energy are related, but does not make connections between evidence obtained from measurement and the question.
On the Path to Proficiency	Clearly restates the question, but does not propose measurements to be taken to evaluate the question or make connections between evidence obtained from measurement and the question.
An Attempt	Unable to clearly restate the question, and unable to propose measurements to be taken to evaluate the question or make connections between evidence obtained from measurement and the question.

Science Practice 4.3 The student can *collect data* to answer a particular scientific question.

Proficient	Collects complete, clearly presented and identified data, with labels.
Nearly Proficient	Collects complete, clearly presented data for the LEDs, but the data is not identified and labeled.
On the Path to Proficiency	Collects partial data for the LEDs, or the data is not clearly presented, identified, or labeled.
An Attempt	Collects partial data for the LEDs; none of the data is clearly presented, identified, and labeled.

Science Practice 5.1 The student can *analyze data* to identify patterns or relationships.

Proficient	Includes a mathematical representation (including a graph) of the model describing the relationship of energy and frequency with the meaning of each variable identified and expressed in a form consistent with the observed data. There is a reasonable discussion of precision of data and possible sources of uncertainty.
Nearly Proficient	Includes a mathematical representation or graph of the model describing the relationship of energy and frequency with the meaning of each variable identified, but it is not expressed in a form consistent with the observed data. The data analysis does not include a clear discussion of precision or possible sources of uncertainty.
On the Path to Proficiency	Includes a mathematical representation of the model with the meaning of each variable identified, but it is not expressed in a form consistent with the observed data or that describes the relationship of energy and frequency. The data analysis does not include any discussion of precision or possible sources of uncertainty.
An Attempt	Includes a mathematical representation of the model, but the meaning of each variable is neither identified nor expressed in a form consistent with the observed data or that shows the relationship between energy and frequency. The data analysis does not include any discussion of precision or uncertainty.

Science Practice 6.2 The student can *construct explanations of phenomena based on evidence* produced through scientific practices.

Proficient	Clearly restates the interaction of energy and matter, and the explanations of the effect of changes in intensity and the concept of threshold frequency are clear and concise.
Nearly Proficient	Clearly restates the interaction of energy and matter, but either the explanation of the effect of changes in intensity or the concept of threshold frequency contains flaws.
On the Path to Proficiency	Does not clearly restate the interaction of energy and matter, and the explanations of the effect of changes in intensity and the concept of threshold frequency contain major flaws.
An Attempt	Does not clearly restate the interaction of energy and matter, nor does the explanation include the effect of changes in intensity or the concept of threshold frequency.

Science Practice 6.4 The student can *make claims and predictions about natural phenomena* based on scientific theories and models.

Proficient	Prelab summary: Makes clear predictions about the differences between the flashlight and the mercury-vapor lamp and about the dependence on distance to photon source, metal type, and area of contact.
Nearly Proficient	Prelab summary: Describes the difference between the flashlight and the mercury-vapor lamp but explains the dependence on only one of the variants — either distance to photon source, metal type, or area of contact.
On the Path to Proficiency	Prelab summary: Includes discussion of variation due to metal type, but does not explain the difference between the flashlight and the mercury-vapor lamp, dependence on distance to photon source, dependence on metal type, or dependence on area of contact.
An Attempt	Prelab summary: Does not articulate the difference between the flashlight and the mercury-vapor lamp, dependence on distance to photon source, dependence on metal type, or dependence on area of contact.

Science Practice 7.1 The student *can connect phenomena and models* across spatial and temporal scales.

Proficient	Correctly identifies both the features of the wave model of light that are and are not consistent with diffraction and the features of the particle model of light that are and are not consistent with the photoelectric effect.
Nearly Proficient	Correctly identifies either the features of the wave model of light that are and are not consistent with diffraction or the features of the particle model of light that are and are not consistent with the photoelectric effect.
On the Path to Proficiency	Incorrectly identifies some aspects of the wave model of light that are and are not consistent with diffraction, and incorrectly identifies the features of the particle model of light that are and are not consistent with the photoelectric effect.
An Attempt	Does not correctly identify any features of the wave model of light that are and are not consistent with diffraction, and does not identify features of the particle model of light that are and are not consistent with the photoelectric effect.

Supplemental Resources

“DIY Science: Measuring Light with a Photodiode II.” Outside Science. Accessed September 1, 2014. <http://outsidescience.wordpress.com/2012/11/03/diy-science-measuring-light-with-a-photodiode-ii/>.

“Energy Skate Park.” PhET. University of Colorado Boulder. Accessed September 1, 2014. <https://phet.colorado.edu/en/simulation/energy-skate-park>. [This simulation can be set with an “energy bar graph” similar to what students might construct for the energy of a charged particle in an electric field.]

Fisher Scientific. Accessed September 1, 2014. <http://www.fishersci.com/ecomm/servlet/home?storeId=10652>.

Garver, Wayne P. “The Photoelectric Effect Using LEDs as Light Sources.” *The Physics Teacher* 44, no. 5 (2006): 272–275.

Gende, Dolores. “Graphing Analysis in Modern Physics.” In *AP Physics: Special Focus: Graphical Analysis*. New York: The College Board, 2006.

Knight, Randall. “Using Multiple Representations to Understand Energy.” In *AP Physics: Multiple Representations of Knowledge: Mechanics and Energy: Special Focus*. New York: The College Board, 2008.

Kwasnoski, John B. “A Laboratory Investigation of Light-Emitting Diodes.” *American Journal of Physics* 40, no. 4 (1972): 588–591.

Lai, Shu T. *Fundamentals of Spacecraft Charging: Spacecraft Interactions with Space Plasmas*. Princeton, NJ: Princeton University Press, 2012.

LED diffraction lesson. University of Wisconsin-Madison. Accessed September 1, 2014. <http://www4.uwm.edu/ret/projects/physics/highschool/upload/LEDdiffraction.pdf>.

McKagan, S.B., W. Handley, K.K. Perkins, and C.E. Wieman. "A Research-Based Curriculum for Teaching the Photoelectric Effect." *American Journal of Physics* 77, no. 1 (2009): 87–95.

"Photoelectric Effect." PhET. University of Colorado Boulder. Accessed September 1, 2014. <http://phet.colorado.edu/en/simulation/photoelectric>. [*This simulation based on the work of McKagan, et al.*]

Planinšič, Gorazd, and Eugenia Etkina. "Light-Emitting Diodes: A Hidden Treasure." *The Physics Teacher* 52, no. 2 (2014): 94–99.

"Spectrometer." Public Lab. Accessed September 1, 2014. <http://publiclab.org/wiki/spectrometer>.

Singer, Susan R., Margaret L. Hilton, and Heidi A. Schweingruber. *America's Lab Report: Investigations in High School Science*. Washington, DC: The National Academies Press, 2006.

von Lenard, Philipp E. A. "On Cathode Rays." Nobelprize.org. Accessed September 1, 2014. http://www.nobelprize.org/nobel_prizes/physics/laureates/1905/lenard-lecture.pdf.

This page is intentionally left blank.