

CITY OF URBANA
DEPARTMENT OF PUBLIC WORKS



ADA TRANSITION PLAN

2012 UPDATE

PUBLIC RIGHTS OF WAY

AND

SIDEWALK

TABLE OF CONTENTS

I.	INTRODUCTION	1
II.	BACKGROUND	1
III.	SELF-EVALUATION	1
IV.	COMPLIANCE PROGRAM.....	2
V.	IMPLEMENTATION SCHEDULE.....	3
VI.	PROGRAM RESPONSIBILITY	4
VII.	PUBLIC INVOLVEMENT	4
VIII.	ACCOMMODATION PROCEDURE.....	4
IX.	APPENDICES	5

I. INTRODUCTION

The 2012 ADA Transition Plan supersedes and takes the place of Section IV. Title II: G. Curb and sidewalk ramps; and, H. Parking accessibility of the City of Urbana Americans With Disabilities Act Compliance Plan, in effect since July, 1993. This plan is in accordance with the guidelines of the Illinois Department of Transportation (IDOT), Americans with Disabilities Act (ADA). When the City of Urbana Transition Plan is in conflict with the IDOT guidelines, IDOT guidelines shall take precedence.

The purpose of this transition plan is to:

- Conduct a new self-assessment and inventory of needs.
- Solicit public input to increase awareness and effectiveness of the plan.
- Incorporate new practices and procedures into the plan.
- Develop an implementation schedule for the plans.
- Compliance attainment with ADA guidelines.

II. BACKGROUND.

The City of Urbana Department of Public Works surveyed all its sidewalk ramps in 1991 to assess ADA compliance.

In 1993 the city adopted an ADA compliance plan to reconstruct non-compliant sidewalks to meet the then current ADA standards. The 1993 American with Disabilities Act Compliance Plan is provided in Appendix A.

III. SELF-EVALUATION

Public Works Department staff will begin a new inventory survey in the summer of 2012. The Public Works Department will create a geographic information system (GIS) based map and database to inventory ramp data. The GIS database will also be utilized to prioritize and track ramp reconstruction activities.

Ramp survey forms are presented in Appendix B.

IV. COMPLIANCE PROGRAM

Priority system

Priorities can be set by addressing both the needs and physical conditions of the ramps.

From a needs perspective the following should be considered:

- A. Presence of a disabled population or specific complaints and/or requests from a disabled person or advocacy group (10 points).
- B. High volume of pedestrians, such as in the Central Business District or University District, schools (8 points), public buildings, hospitals, senior housing, libraries, public transportation facilities, or parks (6 points).
- C. Low volume pedestrian use areas such as residential subdivisions (2 points).
- D. Alternative ADA compliant sidewalk route within 1 block radius (-3 points).
(Deduction meant to lower priority based on close proximity to a compliant route).

From a ramp condition perspective the following should be considered:

- 1. There is no ramp at a pedestrian crossing in an area with sidewalks (8 points).
- 2. Existing ramp which is unsafe due to deterioration (1 to 3 points), excessive slopes (1-3 points), or abrupt changes in the surface elevations (maximum of 7 points total).
- 3. Where ramps are generally safe and in good condition but do not fully comply (no detectable warnings with domes, side tapers are out of compliance, etc.) (1 point).

Each ramp location will be rated according to these criteria. Specific projects designed to replace ramps to correct deficiencies will address those rated numerically highest until budgeted funds are exhausted.

Requirement to Act

All new development and redevelopment must have accessible walks and ramps in full compliance with accessibility standards as required in the city's Subdivision and Land Development Code (Section 21-58).

Alterations of facilities in the public right-of-way must make changes to sidewalks and ramps to meet current ADA standards. Alterations are changes which affect the usability and are broadly interpreted to include work such as road reconstruction, sidewalk repairs, asphalt overlay of the street, or utility repairs that affect the sidewalks or ramps. When work involves one corner of an intersection only that corner must have the curb ramps improved to current ADA standards and the adjacent pavement must be resurfaced as necessary to provide for a flush transition. All sidewalk work greater than 10' in length that abuts a curb ramp shall be extended to include affected ramps and those ramps must be improved to current ADA standards.

The city will also reconstruct all non-compliant sidewalk ramps during adjacent street reconstruction and resurfacing projects. The city estimates approximate (40) sidewalk ramps will be reconstructed each year as part of street construction resurfacing projects.

V. IMPLEMENTATION SCHEDULE

Winter 2012 – Spring 2012 - Completed

- Create GIS based inventory system of all Urbana sidewalk ramps.

Spring 2013 – Fall 2015

- Survey all Urbana sidewalk ramps

Fall 2015 – Winter 2016

- Rank and prioritize all non-compliant sidewalk ramps.

Spring 2015 – To be determined by results of the survey and available funding

- Implement sidewalk ramp reconstruction efforts based on inventory priority ranking system.

After completion of the sidewalk ramp survey the City will know how many non-compliant ramps exist and can then finalize a ramp reconstruction schedule to bring those ramps up to current ADA standards.

Sidewalk ramp reconstruction efforts will be tracked in the GIS based sidewalk inventory system to maintain a current list of non-compliant sidewalk ramps and track the number of sidewalk ramp reconstructions that the City has completed as part of its ADA Transition Plan efforts.

VI. PROGRAM RESPONSIBILITY

The official responsible for implementation of the City's ADA Transition Plan in Public Rights-of-Way is:

William R. Gray
Director of Public Works
706 South Glover Avenue
Urbana, Illinois 61802
Telephone: (217) 384-2342
Fax: (217) 384-2400
Web site: www.urbanaininois.us

The City of Urbana ADA Coordination is the responsibility of the Engineering Division of the Public Works Department.

VII. PUBLIC INVOLVEMENT

A meeting was held with the Bike and Pedestrian Advisory Committee (BPAC) on February 21, 2012 to solicit their input on the ADA Transition Plan. The BPAC members did not have any comments regarding the Transition Plan.

The Transition Plan was also reviewed by a member of the Champaign Urbana Urbanized Transportation Study (CUUATS) group. The CUUATS review comments are provided in Appendix C.

The ADA Transition Plan was also posted on the city website for public review and comment from May 11, 2012 to June 15, 2012.

The ADA Transition Plan was adopted by motion of the Urbana City Council on July 23, 2012.

VIII. ACCOMMODATION PROCEDURE

The accommodation process is an integral part of the ADA Transition Plan. Accommodations will be evaluated according to the policies, practices, and available funding sources. Within the Department of Public Works, the Engineering Division will receive and evaluate accommodation requests.

Accommodation Process: The Engineering Division acts as the central clearinghouse for curb ramp and sidewalk accommodation requests. Citizens with disabilities requiring

curb ramps are encouraged to contact the office directly at 217-384-2342. Accommodation requests received by other departments or agencies will be routed to the Engineering Division. This central accommodation request processing procedure ensures that the specific needs of each individual are accurately understood and recorded. The deficiency and specific location are then entered into a log and the matter referred to the Engineering Division for inspection and possible action. The Engineering Division then coordinates any work and keeps a record of all formal responses to the requester. A request for accommodation form is provided in Appendix C.

Accommodation requests may be received through a variety of communication methods:

John Lyons, P.E.
Civil Engineer
Department of Public Works
706 South Glover Avenue
Urbana, Illinois 61802
Telephone: (217) 384-2342
Fax: (217) 384-2400
email: jglyons@urbanaininois.us

Website www.urbanaininois.us

IX. APPENDICES

Appendix A	1993 American with Disabilities Act Compliance Plan
Appendix B	Inspection Forms
Appendix C.	CUUATS Comments on ADA Transition Plan
Appendix D.	Request for Accommodation / Sidewalk Repair Form
Appendix E.	City Design Standards

APPENDIX A

1993 AMERICAN WITH DISABILITIES ACT COMPLIANCE PLAN



American With Disabilities Act Compliance Plan

Program Accessibility Addendum

Prepared in Conjunction with PACE and U-CAN

July, 1993

INTRODUCTION

This document is an addendum to the City of Urbana's Americans with Disabilities Act (ADA) Compliance Plan (hereinafter called the "Plan") which the City Council adopted on January 18, 1993. The City Council directed Staff to work with persons with disabilities to enhance the Plan where needed. Staff met with representatives of Persons Assuming Control of their Environment (PACE) and the Universal Community Access Network (U-CAN) to identify issues for Plan enhancement. Program Accessibility was identified as a specific area of concern and one in which additional commitment is needed. This Addendum is intended to provide additional detail on program accessibility. The Addendum is considered an amendment to the City's ADA Compliance Plan and is formally adopted by the City Council.

Program Accessibility - Defined

Program Accessibility is the means by which the City of Urbana will provide access to a variety of programs, services and public meetings to persons with disabilities. This access can include providing assistance such as interpreters for the deaf, building accessibility, or other needs. If persons with particular disabilities encounter barriers which require assistance, the City will pledge reasonable accommodation of assistance requests per the policy described below.

Program Accessibility also includes the means by which the City will disseminate information to persons with disabilities and the general public on service provisions. These can include brochures, advertising and other means to educate people on the availability of assistance. The primary contact for requests for assistance is the ADA Coordinator, City of Urbana, 400 S. Vine Street, Urbana, Illinois 61801. The phone number is 384-2466 or TTY 384-2447. In the event the ADA Coordinator cannot be reached, persons should contact the City Clerk at 384-2362.

Public Meetings

The City of Urbana has numerous public meetings held by several departments and divisions. A list of some of those regularly scheduled meetings are noted below.

The Urbana City Council holds public meetings on the first floor of the Urbana City Building in the City Council Chambers. The Council will meet in the Mayor's office on the second floor when closed session meetings are required. These closed session meetings are not open to the public. Their location may have to be reconsidered if disabled Council or staff members cannot be accommodated in the Mayor's office.

Urbana Plan Commission conducts regular meetings and public hearings in the Urbana Council Chambers as well. In addition, the Community Development Commission, the Human Relations Commission, the Civil Service Commission, the Zoning Board of Appeals and several other boards and *ad hoc* committees meet in either the City Council Chambers or the Community Development Services Department. Occasionally these boards and commissions meet elsewhere in the community. For example, the Community Development Commission often times meets in the neighborhoods it represents. The City is committed to conducting its hearings and business in accessible locations. It shall be established policy that the City will not conduct or sponsor meetings in facilities that are not accessible. (Please note that the current City Building has some accessibility limitations as noted in the Compliance Plan. These will be addressed over the longer term).

This accessibility policy also applies to one on one meetings with officials or staff. City representatives whose offices are currently inaccessible will arrange to meet with persons with disabilities in an accessible location like the first floor of the City Building.

Accessibility to Day to Day Services

There may be access problems in each department. For example, filling out a form or leaving a message may be difficult for some persons. If assistance is needed, persons with disabilities need to be made aware that they are welcome and entitled to ask for it. Each City Office will post a sign which reads:

American with Disabilities Act Notice:
If you need assistance in any way, please
notify a staff member.
Thank you.

City staff will then assist the person with a disability with forms, messages or other items that are reasonable requests.

Accessibility to Information

Part of program accessibility is assuring persons with disabilities are provided access to information as well as programs. In this regard, the City will change its meeting notice procedures so that people with disabilities are aware of programs and public meetings. When meetings are publicized in the News-Gazette classified section as is required for formal public hearings, each notice will contain the following or comparable phrase:

Persons with disabilities needing services or accommodation for this hearing should contact the Community Development Services Department at 384-2311 or the City of Urbana's American with Disabilities Act Coordinator at 384-2466 or TTY 384-2447.

Each public hearing notice will include the respective department's phone number as well as the City's ADA Coordinator's phone number. In addition, each agenda for public meetings sponsored by the City of Urbana will include the above phrase.

As stated earlier, the City needs to advertise its ability to accommodate people with disabilities. The City will prepare a brochure (similar to the one attached) that outlines who people should contact and what the City's policy is on accommodation. The brochure will be displayed at each City office and the Urbana Free Library. This brochure information is available in large print and on audio tape to accommodate the blind and visually impaired.

The ADA Coordinator needs increased visibility. When new phone numbers are being reviewed for publication in the local phone book, a separate listing for ADA Coordinator will be included. This will allow persons easier access to the Coordinator and better enable the Coordinator to accommodate the requests.

In addition, the News-Gazette has agreed to publish ADA contact information in their Community Calendar section. This will be a regular part of the publication and will notify persons with disabilities on a regular basis of the City's ADA contact.

For the blind and visually impaired, the City will ask the local radio stations to announce regular meetings and ADA contact as part of the public service announcements (PSA's). The ADA Coordinator will monitor the media PSA's to ensure they are continued on a regular basis.

Requests for Accommodation

The ADA Coordinator will be the primary contact for any accommodation request. Requests for accommodation can include sign interpretation, audio tapes, large print or other assistance. In order for the City to have sufficient time to make arrangements, written or verbal requests must be submitted at least seven days prior to the public meeting. The City will provide interpreters for the deaf, and will consider braille transcripts for particular issues. In addition, audio tapes will be made of all open public meetings. These tapes will be kept for two years after the meeting and made available to persons wishing to listen to them. Requests for tapes should be submitted to the ADA Coordinator or responsible department. The ADA Coordinator or his/her representative will contact the persons submitting the request with a determination as to whether or not the request can be reasonably accommodated. Persons who disagree with the ADA Coordinator's determination may file a grievance with the ADA Coordinator's office per the grievance procedure outlined in the City of Urbana's ADA Compliance Plan.

Summary

The City of Urbana is committed to providing equal access to people with disabilities. This document is intended to address any outstanding barriers to program accessibility that may still exist. Any additions or suggestions should be recommended to the City of Urbana ADA Coordinator at 400 S. Vine Street, Urbana, Illinois 61801.

(C:\desktop.\ADAprog.pln)

*Approved as
amended 1/19/93*

**CITY OF URBANA
AMERICANS WITH DISABILITIES ACT
(ADA)
COMPLIANCE PLAN**

January 6, 1993

TABLE OF CONTENTS

- I. INTRODUCTION
- II. ABOUT THE AMERICANS WITH DISABILITIES ACT
- III. TITLE I: EQUAL EMPLOYMENT OPPORTUNITIES FOR INDIVIDUALS WITH DISABILITIES
 - A. About Title I
 - B. Employer conduct prohibited under the ADA
 - C. General City of Urbana time table
 - D. Review of the essential functions of each job description
 - E. Job application process
 - F. Pension policies and practices
 - G. Hiring
 - 1. Requests for reasonable accommodation
 - 2. Review of procedures for pre-employment medical evaluation
 - H. Leave policies and employee benefit packages
 - I. Training for employees on interviewing, on sensitivity to the public and applicants, and on public contact
 - J. Review of pre and post employment tests, including tests conducted by contractors for the City
 - K. Reasonable accommodations
 - L. Contracts with private sector and non-profit organizations
 - M. City-sponsored social and recreational activities
- IV. TITLE II: NONDISCRIMINATION ON THE BASIS OF DISABILITY IN STATE AND LOCAL GOVERNMENT SERVICES
 - A. About Title II
 - 1. Barrier removal
 - 2. Priorities for barrier removal
 - 3. Alternatives to barrier removal
 - B. City self-evaluation
 - C. City transition plan
 - D. Structural modifications
 - 1. City Building.
 - 2. Police Station
 - 3. Main Fire Station
 - 4. Fire Stations #2 and #3
 - 5. Public Works Center
 - 6. Engineering Annex
 - 7. Community Development Services
 - 8. Urbana Civic Center
 - 9. The Urbana Free Library
 - 10. Jaques House
 - E. Program Accessibility
 - 1. Public Meetings
 - 2. Communications

- F. Requests for reasonable accommodation for structural and program accessibility
 - G. Curb and sidewalk ramps
 - ~~H. Parking accessibility~~
- V. TITLE III: NONDISCRIMINATION ON THE BASIS OF DISABILITY BY PUBLIC ACCOMMODATIONS AND IN COMMERCIAL FACILITIES
- A. Introduction
 - B. City leasing and use of public accommodations
 - C. Building code official assistance plan
 - 1. Informational handout
 - 2. Copies of important publications
- VI. COMPLAINT PROCEDURE
- VII. LOCATIONS OF COPIES OF THE PLAN
- APPENDIX A City of Urbana policy on nondiscrimination against persons with disabilities
- APPENDIX B City of Urbana policy on reasonable accommodation for applicants and employees
- APPENDIX C List of local citizens proficient in American Sign Language
- APPENDIX D Complaint procedure

I. INTRODUCTION

This document summarizes the City of Urbana's effort to identify and satisfy the requirements mandated by the Americans with Disabilities Act (ADA). It is intended to be a flexible document--a dynamic, continuously-evolving plan to address the issues and barriers facing disabled citizens today. The many departmental staff members who prepared this document anticipate that, through the process of citizen input and participation, the City will reach a mutually-acceptable level of accessibility.

The *ADA Compliance Plan* was prepared by the City of Urbana ADA Compliance Task Force, including:

Frank Nesbitt, Human Relations Officer, Coordinator

Richard Dunn, Acting Fire Chief
Ronald Eldridge, Finance Director
William Gray, Director, Public Works
Craig Grant, Building Safety Manager, Community Development
Ronald Gremore, Personnel Manager
Willard Schleiter, Chief of Police
Frederick Schlipf, Executive Director, The Urbana Free Library
Diane Schober, Staff Assistant

Lester Pritchard, Universal Community Networkers (U-CAN), Advisor
Sue Johnson-Smith, Executive Director, People Accepting Control of their Environment (PACE), Advisor
Urbana Human Relations Commission, Advisor
April Getchius, City Planner, Advisor

The *City of Urbana ADA Compliance Plan* is the result of a number of public hearings, City and departmental staff meetings with Mr. Pritchard and Ms. Johnson-Smith, and departmental staff meetings. Public hearings on the City's *ADA Compliance Plan* were held at the Urbana Civic Center, 108 East Water Street, Urbana, on Thursday, July 23, 1992, and on Monday, September 28, 1992. Minutes of meetings are located in the City Clerk's Office.

Throughout the *Plan*, City staff have:

- * Assessed the City's current situation in light of ADA requirements.
- * Prepared short-term transition plans, for steps which can be taken during the 1993 calendar year to meet ADA requirements
- * Prepared long-term implementation plans, for steps which cannot be taken to meet ADA requirements until substantial additional funding becomes available. For the most part, these are steps which required the construction of new or greatly expanded City facilities.

Members of the public, interested or affected individuals, and organizations are encouraged to provide additional comments or suggestions regarding the *City of Urbana*

ADA Compliance Plan. Please contact Frank Nesbitt, ADA Compliance Coordinator, at the City Human Relations Office, 400 South Vine Street, Urbana, IL 61801, or call (217) 384-2466 voice or (217) 384-2447 TDD.

II. ABOUT THE AMERICANS WITH DISABILITIES ACT

The purpose of the Americans with Disabilities Act of 1990 is to bring people with physical or mental disabilities into the mainstream of American life.

The two sections of the Act that apply most directly to the City of Urbana are Titles I and II. Title I is concerned with equal employment opportunities for individuals with disabilities, while Title II is concerned with nondiscrimination on the basis of disability in the provision of state and local government services. Discussion of the application of these two titles to the City of Urbana forms the major portion of this *Plan*.

Title III of the ADA covers nondiscrimination on the basis of disability by public accommodations and in commercial facilities. This title is less centrally relevant to City activities, and it receives briefer coverage in this *Plan*.

In all discussions of ADA compliance, it is important to agree on terminology. The following definitions, which have been derived from the ADA and City of Urbana ordinances, are used as the basis for the discussions in this document.

A. Disability

Disability means a physical or mental impairment that substantially limits one or more of the major life activities of that individual; a record of this impairment; or being regarded as having such an impairment. If an individual meets any of these three tests, the person is considered to be an individual with a disability for the purposes of coverage under the ADA.

B. Discrimination

Discrimination means any practice or act which is unlawful based wholly or partially on the race, color, creed, class, national origin, religion, sex, age, marital status, physical and mental disability, personal appearance, sexual preference, family responsibilities, matriculation, political affiliation, prior arrest or conviction record or source of income of a person.

C. Major life activity

Major life activity means a basic activity that the average person in the general population can perform with little or no difficulty.

D. Physical impairment

Physical impairment means a physiological disorder or condition, cosmetic disfigurement, or anatomical loss affecting one or more of the following body systems: neurological; musculoskeletal; special sense organs; respiratory, including speech organs; cardiovascular; reproductive; digestive; etc. The ADA does not include...

exhaustive list of all of the special conditions, diseases or infections that would constitute physical impairment.

E. Mental impairment

Mental impairment means any mental or psychological disorder, such as mental retardation, organ brain syndrome, emotional or mental illness, and specific learning disabilities. The ADA does not include an exhaustive list of all of the special conditions, diseases or infections that would constitute mental impairment.

F. Reasonable accommodation

The ADA defines an accommodation as consisting of any change in the work environment or the manner in which a job is usually performed that enables an individual with a disability to enjoy equal employment opportunities. Also, any modifications or adjustment to:

- * The job application process that enables a qualified individual with a disability to be considered for an employment position.
- * The work environment or the manner in which a job is performed that enables a qualified individual with a disability to perform the essential functions of that position.
- * That would enable an employee with a disability to enjoy equal benefits and privileges of employment as similarly situated employees without disabilities.

According to the ADA, "supportive employment" is not "reasonable accommodation." The distinction between "supportive employment" and "reasonable accommodation" is complex one. For a full discussion, see:

Ogletree, Bekins, Nash, Smoak, and Stewart. *Americans with Disabilities Act: Employee Rights and Employer Obligations*. Times-Mirror Books, 1992. Section 6.02.

G. Qualified individual with a disability

Qualified individual with a disability means an individual with a disability who, with or without reasonable accommodation, can perform the essential functions of an employment position held or desired.

The ADA excludes from the category of *qualified individuals with disabilities* people with the following conditions: homosexuality, bisexuality, transvestism, pedophilia, transsexualism, exhibitionism, voyeurism, compulsive gambling, kleptomania, pyromania, gender identity disorder, current psychoactive substance use disorder, or other sexual behavior disorders.

III. TITLE I: EQUAL EMPLOYMENT OPPORTUNITIES FOR INDIVIDUALS WITH DISABILITIES

A. About Title I

Title I of the ADA provides that no employer or entity governed by the Act's terms may discriminate against a qualified individual with a disability in terms and conditions of employment. It covers an employer's failure to make reasonable accommodation to the known physical or mental limitations of an otherwise qualified employee or applicant with a disability, except in situations where the accommodation would impose an undue hardship on the operation of the employer.

Title I ensures, among other things, the right of an individual to find and hold a job without being discriminated against due to a known or perceived disability. No employer covered under the ADA may discriminate against a qualified individual with a disability because of the disability. Included here are application procedures; hiring, advancement or discharge of employees; employment compensation; job training and other terms; and privileges of employment. This Title I employment provision applies to units of government, to governmental agencies, and to political subdivisions.

B. Employer conduct prohibited under the ADA

1. Employers cannot limit, segregate, or classify employees or applicants in a way that adversely affects the job opportunities or status of disabled persons.

This means individualized decisions, not presumptions, prejudices, or generalized fears about what a disabled person can or cannot do. For example, employers cannot decline to hire a disabled person based on fears of high absenteeism, insurance rate increases, increased costs, inconvenience that might be caused by accommodations, or resentment by co-workers.

2. Employers cannot enter into contractual or other relationships which subject a disabled employee to discrimination.

This includes labor contracts, training programs, and other contractual relationships. Examples of such unacceptable contracts include discriminatory job requirements in a labor contract, or a contract with a company to provide training which will be given at an inaccessible site.

3. Employers cannot utilize standards, criteria, or methods of administration that have the effect of discrimination.

4. Employers cannot make adverse decisions about an employee or applicant because that employee or applicant has a known relationship or association with a person with a known disability.

For example, an employer cannot refuse to hire an applicant because the applicant's spouse or friend is disabled.

5. Employers must make a reasonable accommodation unless such accommodation would impose an undue hardship

Qualification standards, tests, or other selection criteria which tend to screen out disabled persons are unacceptable unless the standards, tests, or selection criteria are shown to be job-related and consistent with business necessity.

6. The ADA does not permit retaliation

Retaliation is discrimination against an individual on the basis of that individual filing a charge, testifying, assisting, or participating in any manner in an investigation, proceeding, or hearing protected under the provisions of the ADA.

C. General City of Urbana time table

It is the intent of the City of Urbana to bring all of its employment practices and documentation formally in line with the requirements of the ADA by no later than December 31, 1993.

D. Review of the essential functions of each job description

The City is reviewing all job descriptions to determine which tasks are essential to the job. It is working to update and clarify all job descriptions that are too vague, broad, or general. It is focusing special attention on positions in public safety and public works. Essential functions have already been established for non-management/supervisory positions in the Public Works Department, and they are being established for positions in the Fire and Police Departments. The target date for completing this review is June 30, 1993.

The City will review the job requirements and specifications for all entry level and promotional positions to ensure that these are valid in light of the ADA. The target date for completing this review is June 30, 1993.

E. Job application process

The Personnel Division has revised job application forms to their ensure their compliance with the ADA.

The City has also published a policy on nondiscrimination against persons with disabilities, covering both employees and job applicants. A copy of this policy is attached as Appendix A.

F. Pension policies and practices

Pension policies and practices will be reviewed to ensure their compliance with the ADA. The target date for completing this review is June 30, 1993.

G. Hiring

1. Requests for reasonable accommodation

The City has developed procedures for the review of requests for reasonable accommodation. See Appendix B.

2. Review of procedures for pre-employment medical evaluations

a. Pre-employment medical examinations for non-police and fire positions

The City currently does not conduct pre-employment medical exams for non-public safety positions. If the City decides to conduct such exams on any non-public safety candidates or personnel, the provisions of the ADA will be thoroughly reviewed in advance of implementation.

b. Medical examinations for police and fire positions

The Police and Fire Departments' medical and physical fitness program will be examined by a joint staff committee from the Personnel, Legal, Police, and Fire Departments to determine for what applicants may be tested, and for what an employee may be disqualified from duty. The target date for completing this process is June 30, 1993.

The medical standards for officer fitness for duty will be reviewed and revised. Following this revision, a meeting will be held with Carle physicians to ensure that they conduct fitness for duty examinations based on the revised standards. The target date for completing this process is January 30, 1993.

c. Drug testing procedures

Personnel and Legal are currently reviewing the City's drug-testing procedures for civil rights compliance. The target date for completing this review is May 30, 1993.

H. Leave policies and employee benefit packages

The Personnel Division is reviewing policies on leave and employee benefits as part of its on-going review of all personnel policies.

I. Training for employees on interviewing, on sensitivity to the public and applicants and on public contact

The Personnel Division and the Human Relations Officer will conduct management training for all department heads and supervisors on employment issues included in the ADA. This training will include the following topics: etiquette while interviewing applicants with disabilities, testing applicants and employees under the ADA, selecting applicants, and making reasonable accommodations for applicants and current employees. The target date for completing this training is September 30, 1993.

All employees will be trained on cultural diversity issues, and this should also touch on disability issues as well. The target date for completing this training is December 31, 1993.

J. Review of pre and post employment tests, including tests conducted by contractor for the City

The Urbana Civil Service Commission rules and regulations will be reviewed and amended as needed by September 30, 1993, with regard to pre-employment selection procedures.

K. Reasonable accommodations

It is the intent of the City of Urbana to remain flexible on accommodation issues, and to work with new situations as they arise.

A number of specific steps have already been taken to provide accommodation in the employment process:

- * An employment application instructional pamphlet in Braille is now available through the Personnel Division.
- * The City has secured a list of available people proficient in American sign language, to aid personnel in communication with hearing impaired applicants. See Appendix C.
- * A reasonable accommodation policy for applicants and employees-- dated February 21, 1992--is a part of the City's administrative policy and procedures manual. See Appendix B.
- * Because the space occupied by the Personnel Office on the second floor of the City Building is not fully accessible, arrangements have been made for members of the personnel staff to use space on the first floor to extend services to people who are unable to come to the second floor.

L. Contracts with private sector and non-profit organizations

The City will review contracts with private sector and non-profit organizations to ensure that the City requires their compliance with the ADA. Contracting requirements need to include an ADA Compliance Certification, where appropriate. The target date for completing this review is June 30, 1993.

M. City-sponsored social and recreational activities

All City employees will ensure that all social and recreational activities sponsored by the City are held at sites that are accessible to the disabled.

IV. TITLE II: NONDISCRIMINATION ON THE BASIS OF DISABILITY IN STATE AND LOCAL GOVERNMENT SERVICES**A. About Title II**

Title II of the ADA mandates that public entities, such as the City of Urbana, ensure that disabled individuals have access to services, programs, and activities. The Act states, "No individual shall be discriminated against on the basis of disability in the full and equal enjoyment of the goods, services, facilities, privileges, advantages, or accommodations of any place of public accommodation by any person who owns, leases, or operates a place of public accommodation."

When barriers bar or inhibit persons with disabilities from participating in programs, services, or activities, Title II mandates barrier removal or accessibility to facilitate participation by persons with disabilities.

As of January 26, 1992, public accommodations are required to remove architectural barriers and communications barriers which are structural in nature in existing facilities, where such removal is "readily achievable."

1. Barrier removal

The ADA defines "readily achievable" as those things that can be accomplished or be carried out without much difficulty or expense.

While there are no formulas, the following factors are to be considered.

The nature and cost of the action needed.

The overall financial resources of the site or activity; the effect on expenses and resources; or the financial impact upon the operation of the site or activities.

Each proposed barrier removal action need not be considered in complete isolation when determining what is readily achievable. The cost of other barrier removal actions may be considered as another factor when determining if a barrier is readily achievable.

2. Priorities for removal of barriers.

The ADA suggests priorities that an entity should consider when deciding what is readily achievable. These priorities are not mandatory, but are suggested ways to determine what types of barriers should be mitigated or eliminated first. They are listed as follows:

Access from public sidewalks, parking, or public transportation stops to a building entrance.

Access to any areas where goods and services are made available to the public.

Access to rest room facilities.

Access in any remaining ways to the goods and services provided.

3. Alternatives to barrier removal.

If barrier removal is not readily achievable, the goods, services, facilities, privileges, advantages, or accommodation of an entity shall be made available through alternative methods, if it is readily achievable to do so.

The obligation to engage in readily achievable barrier removal is a continuing responsibility of a local entity. Items that are not readily achievable may become so in the future.

B. City self-evaluation

While there is no requirement by the ADA for periodic assessment, the City of Urbana will continually review its progress toward meeting fully the ADA requirements for barrier removal.

The City of Urbana will continue to consult with local groups concerned with disability issues, such as PACE and U-CAN, to solicit their suggestions for making the City's goods, services, and facilities more fully accessible to the disabled.

Following the requirements of the ADA, City departmental staff have evaluated all City facilities, to determine which areas are deficient in accessibility and require either modifications or accommodations. The results of these detailed evaluations are on file at the Urbana City Clerk's Office, and are outlined in the sections below. The buildings evaluated include:

LOCATION	USE
City Building, 400 S. Vine	Business, Assembly, City Programs, Services
Police Station, 308 S. Vine	Business, City Programs, Services
Main Fire Station, 402 S. Vine	Business, City Programs, Services
Fire Station #2, S. Philo Rd.	Business, No Public Access
Fire Station #3, N. Lincoln Ave.	Business, No Public Access
Public Works Center, 706 S. Glover	Business, Assembly, City Programs, Services
Engineering Annex, 406 S. Vine	Business, City Programs, Services
Community Development Services, 115 W. Main, Second Floor	Business, Assembly, City Programs, Services
Urbana Civic Center, 108 E. Water	Business, Assembly, City Programs, Services
The Urbana Free Library, 201 S. Race St.	Business, Assembly, Library Programs, Services
Jaques House (The Urbana Free Library), 207 W. Elm St.	Business, No Public Access

C. City transition plan

The ADA requires that, after completing a self-evaluation, the City prepare a transition plan with short-term and long-term goals, to address the problem areas identified.

The City's transition plan is summarized below, in sections on structural modification and program accessibility.

D. Structural modifications

1. City Building.

a. Current assessment.

The City Building, along with the Police Station and the Main Fire Station, constitutes the City Complex. These three buildings were constructed in the 1960s, and they are the focus of a detailed architectural study to determine the program needs of the affected departments. This study, when completed, will propose a construction alternative to address all code requirements, accessibility requirements, and space deficiencies.

b. Short-term transition plan.

Modify the Finance Department/counter top
Modify the City Clerk/counter top
Replace/adjust door hardware
Install necessary signage (braille and directional)
Make minimal rest room modifications
Modify site as needed near ramps
Provide sound enhancement for City programs
Modify existing elevator controls, call buttons

Estimated costs: \$7,000

Estimated completion date: August 30, 1993

c. Long-term implementation plan.

Construct an addition to the Complex to address and correct all accessibility issues.

2. Police Station

a. Current assessment

The Police Station is part of the City Complex. See section IV-D-1-a, above, for a discussion of this complex.

b. Short-term transition plan

Modify the public service window
Replace/adjust door hardware
Install necessary signage
Make minimal rest room modifications

Estimated costs: \$3,000

Estimated completion date: August 30, 1993

c. Long-term implementation plan

Construct City Complex addition.

3. Main Fire Station

a. Current assessment

The Fire Station is part of the City Complex. See section IV-D-1-a, above, for discussion of this complex.

b. Short-term transition plan

Modify the first-floor public service counter and add a bell
Replace/adjust door hardware
Install necessary signage
Make minimal rest room modifications

Estimated costs: \$7,000

Estimated completion date: August 30, 1993

c. Long term implementation plan

The Main Fire Station will be made fully accessible when the City complex addition is constructed.

4. Fire Stations #2 and #3

a. Current Assessment

These facilities are staffed by on-duty fire department personnel only. No programs are delivered from these sites, nor do these sites provide any public access or accommodation. It is unlikely that any disabled employee would ever be assigned to these locations.

b. Short-term and long-term transition plan

Because of the points outlined above, no modifications are planned for these buildings.

5. Public Works Center

An addition to this facility is planned for March 1993. Upon completion, the building will be fully accessible, including an elevator. Given this commitment at the relatively short time span, no other transition plan is proposed.

6. Engineering Annex

Upon completion of the Public Works addition outlined above, the Engineering Division staff will vacate the Annex. Since the Annex structure will be demolished soon after this move, no modifications to the Annex are proposed in this Plan.

7. Community Development Services

a. Current assessment

This department occupies leased space at 115 West Main Street, on the second floor. The space has only minimal barriers.

The City complex addition discussed in Section III-D-1, above, will also accommodate the space needs of Community Development Services.

b. Short-term transition plan

Install second handrail on ramp
Replace/adjust door hardware
Install necessary signage
Make minimal rest room modifications
Modify existing elevator call buttons

Estimated costs: \$1,000

Estimated completion date: August 30, 1993

c. Long-term implementation plan.

Community Development Services will be made fully accessible when the City Complex addition is constructed.

8. Urbana Civic Center

a. Current assessment

This facility is provided to the community for social and business gatherings. Some City of Urbana programs are delivered from this facility as well.

b. Short-term transition plan

Modify existing drinking fountain by the addition of a paper cup dispenser
Replace/adjust door hardware
Install necessary signage
Make minimal rest room modifications
Modify exterior ramp

Estimated costs: \$3,000

Estimated completion date: August 30, 1993

9. The Urbana Free Library

a. Current assessment

The Urbana Free Library, built in 1918 and remodeled in 1975, receives approximately 500,000 user visits per year, which emphasizes the need for the fullest possible accessibility. For a number of years the Library Board of Trustees, staff, and local architects have studied the Library's severe deficiencies in both space and accessibility. The results of these studies include several citizen surveys, a 150-page *Building Program*, and a 65-page *Facilities Plan*, calling for extensive expansion and remodeling of the Library.

Upon completion of construction, the Library will be fully accessible and of sufficient size to meet all program needs.

b. Short-term transition plan

Install necessary signage
Modify the existing elevator
Modify the existing drinking fountains by the addition of paper cup dispenser
Modify the existing accessible rest room
Provide a sound enhancement system
Modify the existing front entry for better access to telephones
Install a TDD

Estimated costs: \$14,000

Estimated completion date: August 30, 1993

c. Long-term implementation plan.

Expand and remodel the Library as outlined in the *Building Program* and *Facilities Plan* to achieve complete accessibility.

10. Jaques House

a. Current assessment

The Jaques House is an historic antebellum structure located next door to The Urbana Free Library. It is used for offices for the Library and for the Urban Municipal Documents Center, but not for public access.

Remodeling the Jaques House to meet standards would be difficult and very expensive, and doing so would destroy its historic character. If the Library or Documents Center hires a staff member for whom access to Jaques House work space is not feasible, that person's office will be relocated to an accessible location.

b. Short-term transition plan

No projects are proposed.

c. Long-term implementation plan

When the Library is expanded and remodeled as outlined in the *Building Program* and *Facilities Plan*, the Jaques House will be eliminated as a location for Library functions.

E. Program Accessibility

1. Public Meetings

It is the expressed intent of the City of Urbana to conduct all public meetings and programs in accessible facilities. To accomplish this goal, the ADA Coordinator, in cooperation with the City Clerk and the Director of The Urbana Free Library, will by June 30, 1993:

Develop a procedure for notifying individuals with disabilities of the process for requesting alternate formats for public meetings.

Utilize an ADA mailing list (soon to be developed) and cable TV to inform persons with disabilities of the procedures to follow regarding notification of public meetings held by the City.

Consider alternate formats to be used in public meetings:

- Audio tapes of meetings
- Large-type (18 point or larger) transcriptions of minutes
- Sign language interpreters at public meetings

Determine prior notice requirements for each of these alternate formats, and publicize these to potential users.

Set priorities for situations where the requests for alternate formats at meetings and programs exceeds the financial ability of the City to meet all requests.

2. Communications

a. Telecommunications devices for the deaf (TDD)

i. Current assessment

At this time, TDD communication devices are in use by METCAD for emergency lines. The Department of Community Development Services also utilizes a TDD for communication when necessary.

ii. Short-term transition plan

Utilize the existing TDD located at Community Development for City-wide access. Purchase TDD units for The Urbana Free Library and Public Works by August 31, 1993.

iii. Long-term implementation plan

The need for additional TDD devices will continually be evaluated to determine future locations.

b. Sound enhancement

i. Current assessment

The current public address system in the City Council chambers can be easily accessed by disabled persons in its present configuration. However, to comply with the Act, it is necessary to provide sound enhancement for City programs.

ii. Short-term transition plan

Purchase and install sound enhancement equipment in the City Council chambers and the Library auditorium. The costs are included in Section 1 above.

iii. Long-term implementation plan

Continue to evaluate the need for sound enhancement at other locations for City programs, i.e., neighborhood meetings.

F. Requests for reasonable accommodation for structural and program accessibility

The City will develop procedures for reviewing requests for reasonable accommodation for structural and program accessibility

The target date for completing these procedures is June 30, 1993.

G. Curb and sidewalk ramps

See Urbana's ADA

1. Current assessment

In 1985, the City of Urbana began modifying curbs and sidewalks to facilitate the travel of disabled persons. In 1991, the Operations Division of Public Works surveyed the entire City while preparing a computerized inventory. The survey showed that 1160 ramps, or 62.5% of all possible ramp locations, had been built since 1985. This leaves a remainder of 699 ramps to be installed. For purposes of this Plan, a 2" mountable curb is considered to be accessible. Based upon an average cost of \$500 per ramp, the remaining obligation is \$349,500 in 1992 dollars.

Priorities for future ramp construction include:

- * Areas specifically identified as priorities by disabled persons or organizations
- * Areas which will improve the access to mass transportation.
- * Commercial areas where state and local government offices are located.
- * Areas of general high pedestrian volume.
- * School access routes.
- * Arterial streets.
- * Commercial areas without government offices.
- * Local/residential streets.

2. Short-term transition plan

An in-house program funded through the Public Works operating budget will pay for the construction of approximately forty ramps per year.

Additional funding for sidewalk ramp construction is obtained through the Capital Improvement Plan, as a spin-off benefit from street, sidewalk, and sewer construction projects. The Capital Improvement Plan will pay for an additional thirty new ramps a year.

The first phase will consist of installing ramps on the City right-of-way at the specific request of disabled citizens. Urbana Public Works receives between five to ten requests per year of this type and gives them top priority.

Another part of this phase will involve the location of accessibility ramps in areas where disabled individuals frequently travel by mass transit. It is anticipated that all ramps which meet this criteria will be completed by July 1993.

3. Long-term implementation plan

The second phase will involve constructing ramps in commercial areas where state and local government offices are located, in areas of high pedestrian volume, and in areas where there are school access routes. The approximately eighty ramps to be constructed in these areas should be completed by July 1995.

The third and final phase will take place on arterial streets, in commercial areas without government offices, and on local streets. This will be the largest of all the phases, with about 520 ramps needed. Assuming a five-year phase implementation, with the Capital Improvement Plan on schedule, the City should complete this goal by the year 2000.



* (Priority): Correction Program
Priority addressed by need and/or physical condition.

* New Construction including subdivision

* Chart for specific future projects 1/2 year

- Responsibility
- Public Involvement
- Complaint

* Service Routes

* Design Standards
(add city standards)

H. Parking accessibility

I. Current assessment

A survey of off-street parking sites shows the following breakdown:

LOT NUMBER	METER/RENTAL SPACES	DISABLED SPACES
1	45	2
2	21	1
5	30	2
8	52	2
9	98	2
11	26	2
16	19	1
17	39	2
21	42	2
22	51	2
23	75	1
24	139	0
25	40	2
26	16	1
Library	8	1
Lincoln Square	723	14
Deck	220	7

Each of these lots was designed to meet previous criteria for the number and size of spaces accessible to disabled citizens. However, the ADA standard represents a significant increase in required space size, and its implementation would result in a loss of available parking spaces. Changing parking lots to meet this new requirement would lead not only to the loss of revenue, but also to the loss of extremely valuable parking in the downtown area. Further, the number of available spaces in the Lincoln Square lots and the deck are controlled by contract.

Of all the lots listed above, only lots 22, 23, and 24 have fewer accessible spaces than specified in the ADA. Lot 22 should have one more space, lot 23 two more spaces, and lot 24 four more spaces.

The inadequate number of spaces in lots 22 and 23 will be corrected with the completion of Phase II, Courthouse Parking.

Lot 24 was an existing parking lot when it was purchased as part of the new Lincoln Square Agreement. Since this lot is considered a remote storage lot, too distant from business locations for disabled parking, no disabled parking spaces are planned for this site.

2. Short-term transition plan

No short-term modifications are planned at this time.

3. Long-term implementation plan

As each existing lot is resurfaced, or when any new lot is constructed, disabled parking spaces will be located in the correct size and number.

V. TITLE III: NONDISCRIMINATION ON THE BASIS OF DISABILITY BY PUBLIC ACCOMMODATIONS AND IN COMMERCIAL FACILITIES

A. Introduction

As a public entity, the City of Urbana is not subject to Title III of the ADA, which covers only private entities (see Section II-1.3000, page 1, *Title II Technical Assistance Manual*, January 24, 1992. United States Department of Justice, Civil Rights Division, Office on Americans with Disabilities Act).

However, the City of Urbana is required to assure that any overlap between the requirements of Title II and Title III provisions that would affect the provision of City services will be addressed by contract with the private entities so as to comply with the intent of the Act. The City of Urbana shall further facilitate private sector compliance with the Act by serving as an informational resource for the public through the Building Safety Division.

B. City leasing and use of public accommodations

The City of Urbana will ensure through contract language and visual inspection that all properties which are owned by private entities in which the City of Urbana proposes to conduct its services are in compliance with Title III of the ADA. The City of Urbana will also ensure that the City programs operated within the privately owned structure are in compliance with Title II of the ADA.

C. Building code official assistance plan

In order to further the compliance of private entities with the provisions of Title II of the ADA, the City of Urbana building official will undertake the following actions to inform the owners of private structures and commercial facilities covered by Title

III of the ADA of the existence the Act, and work to facilitate an understanding of its requirements.

1. Informational handout

The building official will provide an informational handout to be included with a building permit application forms, advising persons applying for building permit of:

- * The existence of the Act.
- * An address and phone number of the proper location from which to obtain a copy of the Act.
- * Notification that a copy of the Act is available for review at specific City office

This handout will be completed by June 30, 1993.

2. Copies of important publications

The Building Safety Division will maintain copies of the ADA and a variety of governmental and association publications designed to clarify the requirements of the Act. These will be available at the Division office for consultation by architects, builders, and the general public.

These publications will be available by June 30, 1993.

VI. COMPLAINT PROCEDURE

The City has developed an ADA violation complaint procedure, which is attached as Appendix D.

VII. LOCATIONS OF COPIES OF THE PLAN

Copies of the *City of Urbana ADA Compliance Plan* are located in all City offices. Copies set aside especially for public inspection are located at the Urbana City Clerk's Office and at The Urbana Free Library.

ADMINISTRATIVE POLICY AND PROCEDURE MANUAL

Subject: Nondiscrimination Against the Handicapped	Date: February 21, 1992
---	----------------------------

POLICY STATEMENT

It is the policy of the City of Urbana that the City will not tolerate any unlawful discrimination against handicapped person in its employment practices and will take affirmative action to foster greater opportunities for qualified individuals with known disabilities in the City's workforce.

- A. The City, through its official staff, will make reasonable accommodations of the known physical and/or mental limitation for otherwise qualified handicapped applicants and/or employees, unless such accommodation would be prohibitively expensive or would unduly disrupt the ordinary conduct of business.
- B. Definition: Handicapped means a determinable physical or mental characteristic of a person, including, but not limited to, a "physical or mental impairment that substantially limits one or more of the major life activities of such individual; a record of such an impairment; or being regarded as having such an impairment."
- C. Determinable Physical or Mental Characteristics:
 1. The definition is not confined to only those physical or mental conditions which are grave or extreme in nature. However, it is interpreted as excluding
 - a. conditions which are transitory and insubstantial and
 - b. conditions which are not significantly debilitating or disfiguring.
 2. To be covered, a condition must be "determinable" as recognized clinical or laboratory diagnostic techniques.
- D. If a dispute arises as to whether a condition constitutes a handicap, it is the burden of the person claiming the handicap to establish that the condition results from disease, injury, congenital condition of birth or functional disorder. For example, the condition of obesity and drug or alcohol abuse shall not be deemed "handicap" unless the person can demonstrate that the condition arises from or constitutes an equivalent of a disease or functional disorder.

Provided by Deaf Services of PACE Inc.
217-344-5433 Voice
217-344-5024 TT

1717 Philo Rd.
Urbana IL 61801
217-344-2414 Fax

Interpreter Referral List May 1992

*The general rule of thumb is, interpreters must be provided for:
Job Interviews, Job Training, Job Evaluations, Dr. Appointments, Direct Services That Are Normally Provided Face to Face, Classes Offered to the Public, Civil Service Exams, Drivers License Examinations, All Courtroom Activities, Emergency Room, And Much More
Please call PACE if you have any questions about the list, the law, or the services. PACE recommends checking references and using the most qualified interpreter available.

Registry of Interpreters For the Deaf-Certified

Shelia Chapman	217-243-3562 TT/Voice 217-479-4205 TT/Voice	Springfield- will travel for full day events.
* Jean P. Clarkson, M.S.	217-359-6213 TT/Voice 217-333-3876 Voice only 217-391-0333 Voice only	Home Office Beeper
Marilyn (Brass) Codier	815-933-9164 TT/Voice	Kankakee area-will travel for full day events.
* Janet Fries	217-367-6789 TT/Voice	
Therese Rear	217-352-1293 Voice only	
Jenny Singleton	217-337-1195 TT/Voice	Limited Availability Court, Evening, Weekends

Interpreter Training Program

Bunny Berg	217-399-6067 TT/Voice 217-244-3962	
Joyce McNeil	217-684-2841 Voice only	Some Coursework/10 yrs. Exper.

Five or More Years Experience

Jane Carr	217-359-8709 TT/Voice	Midway through Certification process
Eldosta Curry	217-429-3573 Voice only 217-424-3256	Training in interpreting for Deaf/Blind-13 yrs experience
Debbie Gello	217-643-2181 Voice only	
Rose Panepinto	217-328-4423	
Pat Separy	217-586-2587	
Cynthia Wachter	217-399-5820 TT/Voice	20 yrs. Interp. Parents are Deaf

Minimal Experience

Donna Adcock	217-422-1206 Voice only	From Decatur area
Therese Pastore Wilson	217-469-8865 Voice only	
April Paul	217-892-2027 Voice only 217-893-9249 Voice only	

ADA COMPLAINT PROCESSING PROCEDURES

- I. Purpose This policy provides a procedure to process complaints alleging that services, programs, and activities of the City of Urbana do not meet the requirements of the Americans With Disabilities Act of 1990 (ADA).
- II. Scope This policy applies to all services, programs, and activities provided by the City of Urbana.
- III. Responsibilities
 1. The Human Relations Officer (HRO) is responsible for complaint intake.
 2. Affected department and division heads are responsible for information gathering relative to the specific allegation of a violation of the ADA.
 3. The HRO is responsible for disposition of the complaint.
 4. The Chief Administrative Officer (CAO) is responsible for review of the disposition of complaint at the request of the complainant. The CAO, at his/her discretion, may consult with the Human Relations Commission in determining a solution in a complaint resolution.
- IV. Procedure
 1. Person making complaint (Complainant). Any person, including employees of the City of Urbana, may file a complaint alleging that the City has failed in a program, activity, or service to fulfill a requirement of the ADA.
 2. To Whom Complaint is Made.
 - A. Complaint may be made verbally or in writing to a department or division head or to the HRO. If the complaint is made verbally, the department head or the HRO shall reduce the complaint to writing. After verbal complaints are reduced to writing, the complainant shall receive a copy and shall either verify its validity or make appropriate changes. The complainant may request a face to face meeting with the HRO or department head to make a verbal complaint. Upon receiving such a request, the HRO or department head shall find an accessible site to meet with the complainant. Such site shall provide the maximum degree of privacy and be agreeable with the complainant.
 - B. If the HRO is the complainant, the complaint shall be made to the CAO who shall, at his/her discretion, be responsible for appointing someone

or personally assume all of the duties and functions of the HRO as described in this complaint process.

- C. The written complaint shall, at a minimum, contain the information contained on the form attached hereto entitled "ADA Complaint Form."

3. Complaint Resolution

- A. If the complaint is made to a department head, such department head shall gather all information relative to the complaint and forward that information to the HRO.
- B. If the complaint is made to the HRO, the HRO shall send a copy of the complaint to the affected department head within one (1) working day after receipt of complaint.
- C. The department head shall forward all information relative to the complaint within five working days after the receipt of the complaint. When the matter/issue involves a personnel policy, the Personnel Manager shall cause the information provided by the department head to be supplemented if necessary. The HRO shall be responsible for informing the Personnel Manager of such complaint.

4. Investigation

- A. The HRO shall review the relevant information and determine whether further information is required from City staff or the complainant. Should further information be required, the HRO shall request the information within ten (10) working days. The HRO has thirty (30) working days from receipt of the complaint to process and provide a recommended solution.
5. The HRO shall review the information in consultation with the CAO and arrive at a disposition of the allegation(s) contained in the complaint as follows:
- A. A written determination that supports or refutes the allegation(s) that the Americans with Disabilities Act requirements have not been met. The written narrative will outline the facts bearing on the decision that was arrived at.
 - i. Should those facts support a finding that the ADA requirements have not been met, the HRO shall consult with the CAO and appropriate City staff to determine remedial action to fulfill ADA requirements and a proposed timetable for the action(s) to be taken.

- ii. Should the facts support a finding that the ADA requirements have been met, the HRO shall cause a conciliation meeting to be convened (when requested) to explain the information developed during the investigation.
 - B. When a complainant requests a conciliation meeting, the CAO shall designate the affected department head to assist the HRO in resolving differences between the complainant's allegation(s) and the determination by the HRO.
 - C. A copy of the disposition of the complaint shall be sent to the complainant and the affected department heads. The HRO shall keep abreast of steps the City staff identifies as necessary to resolve the complaint's allegation(s) and will inform the complainant at the time the corrective measures have been fully implemented. The notification shall be reduced to writing and mailed to complainant.
6. **Communication with Complainant**
- A. The HRO shall make every attempt to communicate with the complainant by telephone or in writing in a manner agreeable to the complainant as long as the complaint is pending. This communication will be for the purpose of advising the complainant of the status of his/her complaint.
 - B. The disposition of the complaint notice shall also inform the complainant that the CAO will review the disposition if requested to do so within fourteen (14) days after the disposition has been sent or given to the complainant.
 - C. **Timely Complaint Processing**
The allotted times and deadlines mentioned above in the complaint processing procedures above shall be adhered to unless the CAO allows an extension due to unusual or unforeseen circumstances. Whenever an extension of time is granted, the HRO shall be notified. The HRO will in turn notify the complainant by U.S. mail and provide an overview of the process.

AMERICANS WITH DISABILITIES ACT

COMPLAINT FORM

CITY OF URBANA

Name (Please Print): _____

Address: _____

Phone No.: (Home) _____ (Work) _____

Complaint: _____

Relief Requested or Suggested: _____

Date of Complaint: _____

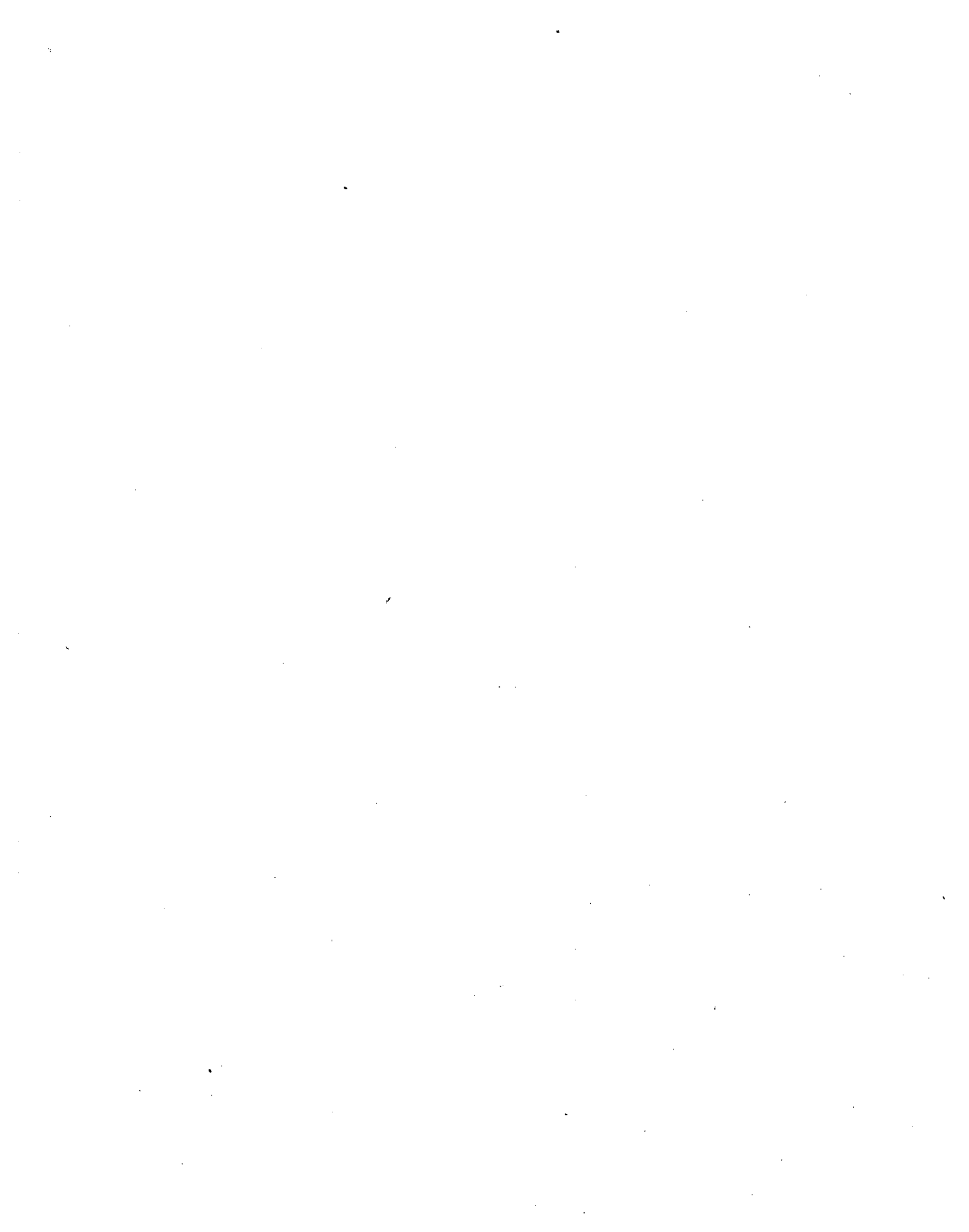

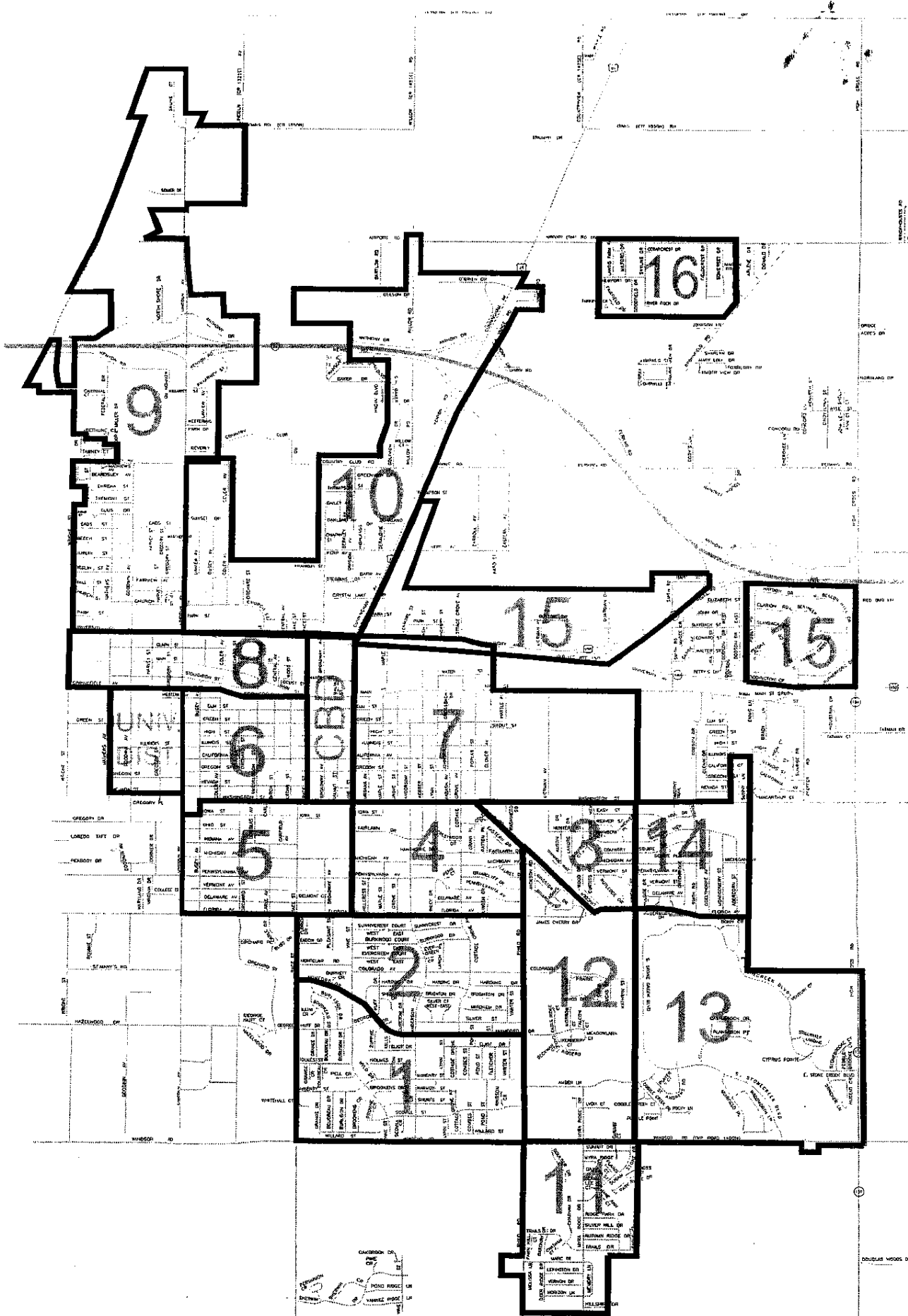

 North
 10/10/10

Residential Areas Index

APPENDIX B

INSPECTION FORMS

ADA CURB RAMP EVALUATION CHECKLIST

PERPENDICULAR RAMPS AT CORNER

Inspection Date: _____
 Inspected By: _____

Location: _____

Note location on Map, Label Streets

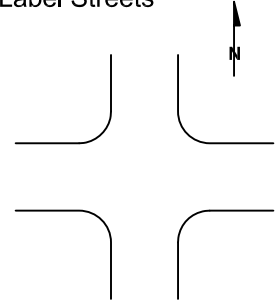
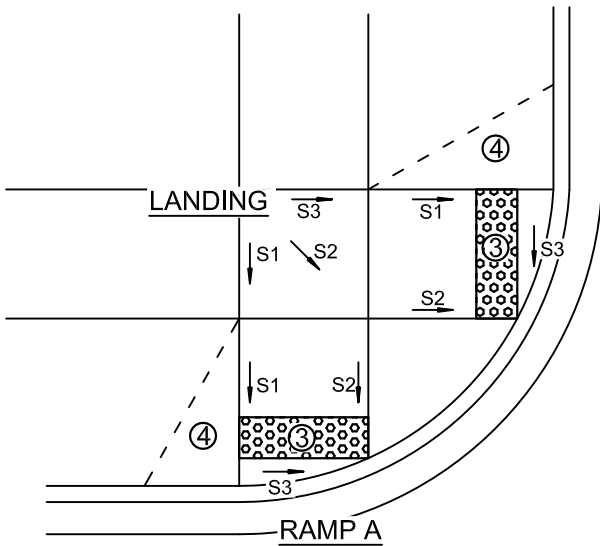

RAMP B

- 1.) Are there existing ramps? Yes / No
- 2.) Is either existing ramp deteriorated? Yes / No
 If Yes, which one? A / B / Both
 (Panels broken into three or more pieces)
- 3.) Are truncated domes present and in satisfactory condition? Yes / No If No, which one? A / B / Both

- 4.) If side tapers are present, are they less than or equal to a 10:1 slope?
 Ramp A: Yes / No / Not Present If No, what is the slope? _____
 Ramp B: Yes / No / No Present If No, what is the slope? _____

- 5.) Are manholes, handholes or valves located within the ramps or landing?
 Ramp A: Yes / No Ramp B: Yes / No Landing: Yes / No

- 6.) Do heaved panels exist within the ramps or landing?
 Ramp A: Yes 0.5"-1" / No 1"-2" >2"
 Ramp B: Yes 0.5"-1" / No 1"-2" >2"
 Landing: Yes 0.5"-1" / No 1"-2" >2"

7.)

	RAMP A	RAMP B	LANDING
SLOPE 1 (S1)			
SLOPE 2 (S2)			
SLOPE 3 (S3)			

- 8.) Use back of sheet for additional comments

ADA CURB RAMP EVALUATION CHECKLIST

COMBINATION RAMP AT MID-BLOCK

Inspection Date: _____
 Inspected By: _____

Location: _____

Note location on Map, Label Streets

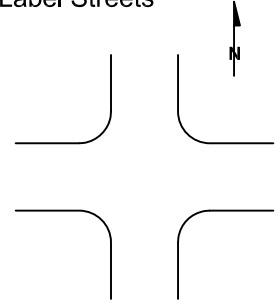
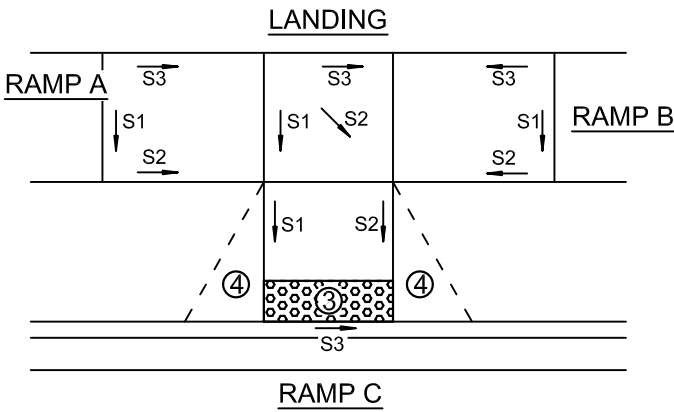

- 1.) Are there existing ramps? Yes / No
- 2.) are any existing ramps deteriorated? Yes / No
 If Yes, which one? A / B / C / All
 (Panels broken into three or more pieces)
- 3.) Are truncated domes present and in satisfactory condition? Yes / No

4.) If side tapers are present, are they less than or equal to a 10:1 slope? Yes / No / Not Present
 If No, what is the slope? _____

5.) Are manholes, handholes or valves located within the ramps or landing?
 Ramp A: Yes / No Ramp B: Yes / No Ramp C: Yes / No Landing: Yes / No

6.) Do heaved panels exist within the ramps or landing?
 A: Yes 0.5"-1" / No 1"-2" / >2"
 B: Yes 0.5"-1" / No 1"-2" / >2"
 C: Yes 0.5"-1" / No 1"-2" / >2"
 Landing: Yes 0.5"-1" / No 1"-2" / >2"

7.)

	RAMP A	RAMP B	RAMP C	LANDING
SLOPE 1 (S1)				
SLOPE 2 (S2)				
SLOPE 3 (S3)				

8.) Use back of sheet for additional comments

ADA CURB RAMP EVALUATION CHECKLIST

PARALLEL RAMP AT MID-BLOCK

Inspection Date: _____
 Inspected By: _____

Location: _____

Note location on Map, Label Streets

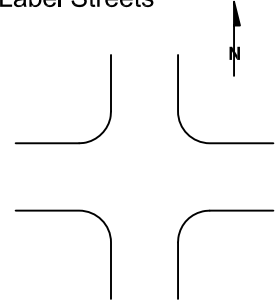
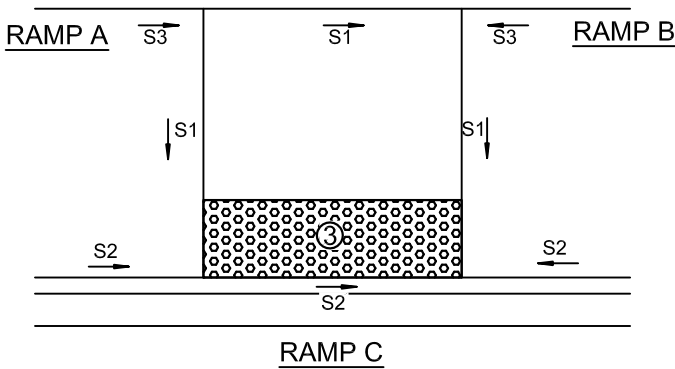

- 1.) Are there existing ramps? Yes / No
- 2.) Are any existing ramps deteriorated? Yes / No
 If Yes, which one? A / B / C / All
 (Panels broken into three or more pieces)
- 3.) Are truncated domes present and in satisfactory condition? Yes / No

4.) Are manholes, handholes or valves located within the ramps?
 Ramp A: Yes / No Ramp B: Yes / No Ramp C: Yes / No

5.) Do heaved panels exist within the ramps?
 Ramp A: Yes 0.5"-1" / No 1"-2" / No >2"
 Ramp B: Yes 0.5"-1" / No 1"-2" / No >2"
 Ramp C: Yes 0.5"-1" / No 1"-2" / No >2"

6.)

	RAMP A	RAMP B	RAMP C
SLOPE 1 (S1)			
SLOPE 2 (S2)			
SLOPE 3 (S3)			

7.) Use back of sheet for additional comments

ADA CURB RAMP EVALUATION CHECKLIST

ATYPICAL RAMP

Inspection Date: _____

Location: _____

Inspected By: _____

Note location on Map, Label Streets

Sketch sidewalk ramp and slope locations

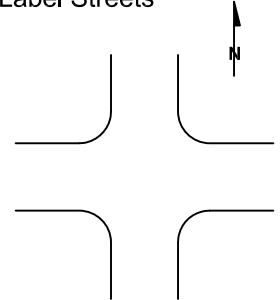

1.) Are there existing ramps? Yes / No

2.) Are any existing ramps deteriorated? Yes / No
Which ones?

(Panels broken into three or more pieces)

3.) Are truncated domes present and in satisfactory condition? Yes / No If No, where?

4.) If side tapers are present, are they less than or equal to a 10:1 slope?

Yes / No / Not Present If No, what is the slope? _____ & Where is it located?

5.) Are manholes, handholes or valves located within the ramps or landing? Yes / No

If Yes, Where?

6.) Do heaved panels exist within the ramps or landing? Yes / No

If Yes, Where?

7.)	RAMP A	RAMP B	RAMP C	LANDING
SLOPE 1 (S1)				
SLOPE 2 (S2)				
SLOPE 3 (S3)				

8.) Use back of sheet for additional comments

APPENDIX B
INSPECTION FORMS

APPENDIX C

CUUATS COMMENTS ON ADA TRANSITION PLAN

From: Rita Morocoima-Black [rmorocoi@co.champaign.il.us]
Sent: Friday, March 02, 2012 4:27 PM
To: Bennett, Brad
Subject: RE: Urbana ADA Compliance Plan

Hi Brad,

Thank you for sending me the ADA Compliance Plan for the City of Urbana. My comments are mainly related to the Priority System that is defined in the document (page 12):

First, I would like to see more consideration of “closeness to trip generators and transportation facilities” as part of the criteria on the “needs” perspective. This can be measured by giving some weight to:

1. Locations with higher concentrations of persons with disabilities
2. Higher volume streets
3. Closeness to public spaces or facilities such as social service agencies, libraries, hospitals, etc.
4. House density (higher density neighborhoods tend to have higher levels of pedestrian activity)
5. Nearness to senior housing facilities
6. Presence of public transportation and level of use of transit stops
7. Closeness to employment centers, park facilities, schools and retail establishments

I also recommend adding weight to the sidewalk conditions(fixed obstructions, changes in level, cross-slope, and running slope) leading to the ramps.

From a ramp condition perspective, I suggest evaluating differently, if the ramps are warranted but missing (priority 1) and locations where ramps exist but are not compliant (priority 2) because they are too narrow, or the ramp is missing the top landing, the ramp is too steep, the ramps are not aligned with the marked crosswalk, the ramps don't have detectable warning surface, etc.

Thanks,
Rita

From: Bennett, Brad [<mailto:bmbennett@urbanaininois.us>]
Sent: Thursday, February 23, 2012 9:01 AM
To: Rita Morocoima-Black
Subject: Urbana ADA Compliance Plan

Rita:

Hi! How are you doing?

The City of Urbana has prepared an update to its ADA compliance plan which is attached for your reference. We were hoping to have CUUATS review and comment on the plan. Would that be possible?

If you have any questions about the Urbana ADA compliance plan please do not hesitate to contact me!

Thanks!

APPENDIX D

**REQUEST for ACCOMMODATION / SIDEWALK REPAIR
FORM**



**DEPARTMENT OF PUBLIC WORKS
REQUEST FOR ACCOMMODATION/SIDEWALK REPAIR
REQUEST FORM**

Reporting Individual

Name _____
(Printed)

Address _____

City, State, Zip Code _____

Telephone Number(s) _____

E-Mail Address _____

Sidewalk Requiring Accommodation

Street _____

Cross Street _____

Street Address _____

Date of Incident or Discovery _____

Describe the reason for requiring the requested accommodation or sidewalk repair. (please feel free to use additional attachments as necessary)

Signature of Reporting Individual _____ Date _____

Please mail to: Engineering Division, City of Urbana Public Works Department
 Attn: John Lyons
 706 South Glover Street
 Urbana, Illinois 61802

Office Use Only

Date Received _____ Received by _____

Action Taken:

Date:

APPENDIX E
CITY DESIGN STANDARDS

DEPRESS CURB ACROSS RAMP (TYP.)
(SEE SHEET SID-A-2)

8" WIDER THAN SIDEWALK

LANDING APPROACH - 5% MAX LONGITUDINAL SLOPE OR NO GREATER THAN ADJACENT STREET SLOPE

A

B

MATCH EXISTING

1.2%(MAX)

MATCH EXISTING

1.2%(MAX)

1.5% MAX. CROSS SLOPE ON SIDEWALKS (TYP)

8.33% MAX. SLOPE

MATCH CURB HEIGHT AT STREET
RUN CURB TO ZERO HEIGHT
(GROUND ELEVATION) IN 6' MINIMUM

1' WIDER THAN SIDEWALK

DETECTABLE WARNING SURFACE INSTALLED PER MANUFACTURER'S DIRECTIONS & PER DETAILS SID-A-2, SID-A-3 *

5' MIN.

2" MIN.

5' MAX' BETWEEN BACK OF CURB & FRONT OF DETECTABLE WARNING PANEL (IF THIS IS NOT POSSIBLE, CONSULT WITH RIGHT-OF-WAY INSPECTOR PH. 217-384-2385

1/2" EXPANSION JOINT (TYP)

PLAN

2" MAX BETWEEN ADA SURFACE & CURB EXPANSION AT CLOSEST POINT

DETAIL SID-A-1

*** NOTES ***

- 1) DETECTABLE WARNINGS SHALL CONSIST OF A SURFACE OF TRUNCATED DOMES MEETING THE REQUIREMENTS OF THE ADAAG. DETECTABLE WARNING SURFACES MAY BE CLAY BRICK PAVERS, CONCRETE PAVERS OR POLYMER CONCRETE PANELS OR OTHER APPROVED SURFACE.
- 2) THIS DETAIL IS FOR GENERAL SIDEWALK AND RAMP LAYOUT DESIGN. PLEASE CONTACT THE ENGINEERING DIVISION AT PH. (217) 384-2385 WITH ANY TECHNICAL QUESTIONS.
- 3) ALL RAMPS AND SIDEWALKS SHALL MEET CURRENT ADA DESIGN REQUIREMENTS.

DATE	REVISIONS
11/23/11	

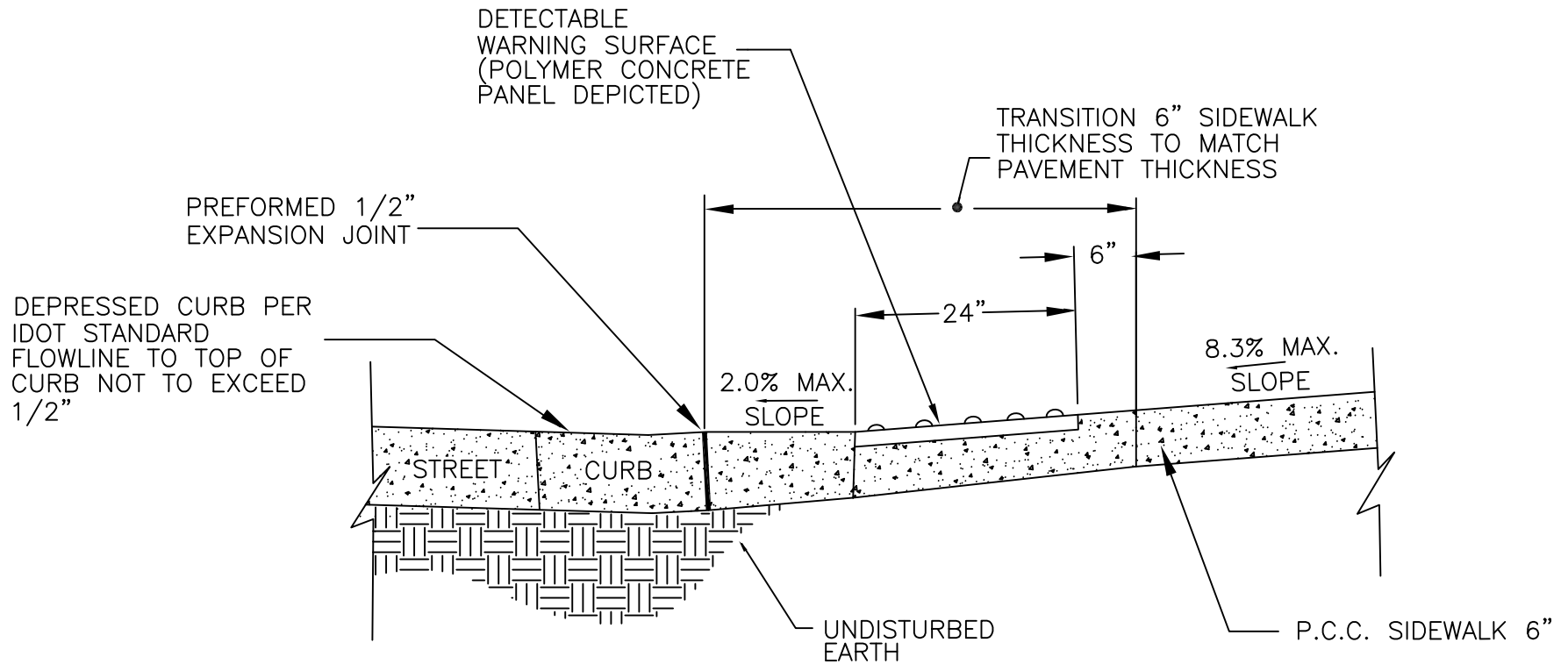

SECTION A-A

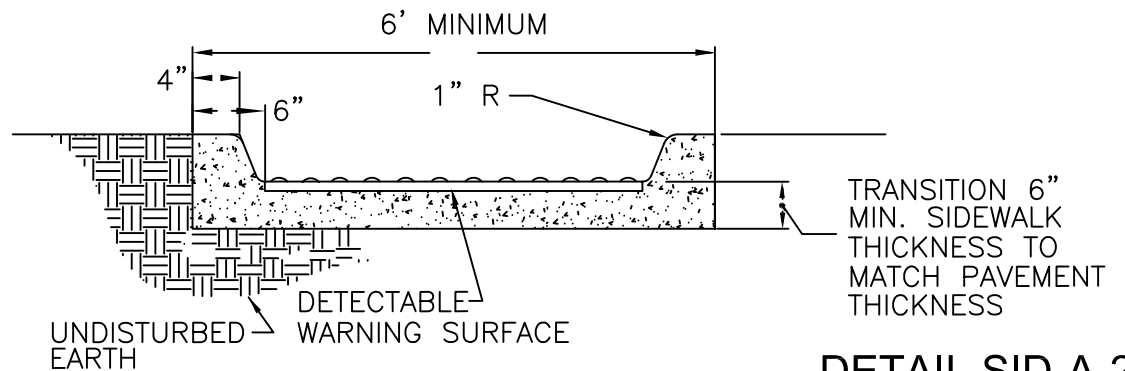

SECTION B-B

**DETAIL SID-A-2
33**

NOTES:

- 1.) DETECTABLE WARNING SURFACE PANELS SHALL BE INSTALLED PER MANUFACTURERS DIRECTIONS.
- 2.) INSTALL 3/8" THICK COMPACTED SAND LEVELING BED UNDER PCC & BRICK ADA PAVERS
- 3.) JOINTS BETWEEN PCC AND BRICK PAVERS SHALL BE 1/8" TO 1/4" WIDE
- 4.) SWEEP FINE GRAIN SILICA SAND INTO PCC & BRICK PAVER JOINTS.
- 5.) SIDEWALKS AND RAMPS SHALL MEET CURRENT ADA DESIGN GUIDELINES.



DATE	REVISIONS
11/23/11	