

TRF7960A RFID Multiplexer Example System

Josh Wyatt

Embedded RF Applications/Systems

ABSTRACT

The purpose of this manual is to describe in concise detail the sixteen channel HF (13.56MHz) RFID Reader System (based on the TRF7960A RFID IC) designed by Texas Instruments for customer use. The system hardware is comprised of one (1) RFID controller board and four (4) antenna boards, along with their associated cables (Power, RF, GPIO and host communication). The system firmware resides on Texas Instruments MSP430F2370 and supports the ISO/IEC15693 protocol in addition to communication with a host. The host software will reside on the controller and the host command details are also described in this manual for their development/integration efforts.

Contents

1	System Theory of Operation/Concept.....	3
2	System Hardware	4
	2.1 RFID Controller Board	4
	2.2 RFID Antenna Board	4
	2.3 System Cables & Connections	4
	2.3.1 Host Communication	4
	2.3.2 Power Cable	4
	2.3.3 RF Cables.....	5
	2.3.4 GPIO/+3.3VDC Cables.....	5
	2.4 ISO/IEC15693 Transponder.....	5
3	System Firmware	5
	3.1 MSP430F2370 Setup	5
	3.2 ISO/IEC15693 Support.....	5
	3.3 GPIO Control.....	6
4	System Host Commands	9
	4.1 Host Commands Structure Definition	9
	4.2 Initiate Communication with RFID Controller Board.....	9
	4.3 Set Protocol.....	10
	4.4 Inventory Command	10
	4.5 Turn off RF Transmitter	10
	4.6 Switch Antenna	11
	4.7 Turn on RF Transmitter	11
	4.8 Read Transponder Data Block(s).....	11
	4.9 Write Transponder Data Block	12
	4.10 Example Application Usage Flow Chart.....	13
5	Performance Measurements/Testing	14
	Code	15
	References.....	15
	Appendix A. Schematics	16
	Appendix B. Layout Images	17

Appendix C. Cable Details18
Figures

Figure 1.	TRF7960A Multiplexer RFID System Block Diagram	3
Figure 2.	PE42440 Functional Diagram and Truth Table	6
Figure 3.	PE4257 Functional Diagram and Truth Table	6
Figure 4.	PE42440 and PE4257 Antenna Circuit Arrangement Detail Diagram	7
Figure 5.	RFID Controller Host Protocol General Format.....	9
Figure 6.	TRF7960A Out (~+23dBm)	14
Figure 7.	TRF7960A to PE42440 Out (~0.5dBm loss).....	14
Figure 8.	TRF7960A to PE42440 to PE4257 out (~0.8dBm loss)	14
Figure 9.	RFID Controller Board	16
Figure 10.	RFID Controller Board	16
Figure 11.	Antenna Board.....	16
Figure 12.	RFID Controller Board Layout.....	17
Figure 13.	RFID Antenna Board Layout	17
Figure 14.	Signal Cascade Concept	18
Figure 15.	Cabling for Signal Cascade Concept	18
Figure 16.	GPIO Cable Diagram	20

Tables

Table 1.	TRF7960A Multiplexer Antenna Truth Table (one board)	7
Table 2.	MSP430 GPIO Switch Logic Matrix (full system).....	8
Table 3.	Host Command Codes for Antenna Selection.....	8
Table 4.	GPIO Cable Pin Out.....	19

1 System Theory of Operation/Concept

The purpose of the system is to read individual RFID transponders (or tags) in up to sixteen different locations. This system goal is accomplished by using one RFID reader controller board and four identical antenna boards (with four antennas on each board) each of which are cascaded. See Figure 1 for the main system block diagram.

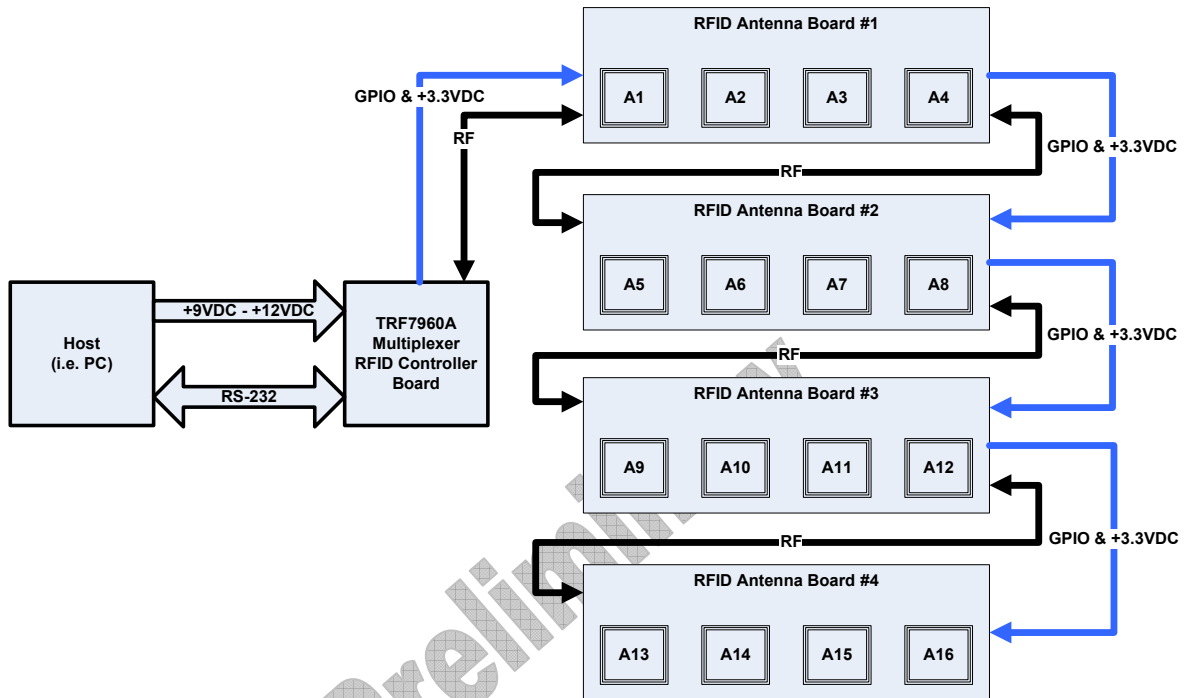

Figure 1. TRF7960A Multiplexer RFID System Block Diagram

The system design shown above in Figure 1 was done to the project requirements for one antenna board design (with four addressable antennas onboard) and a simplified wired connectivity scheme which allows for four of these identical antenna boards to be connected to each other and the RFID controller board with the absolute least amount of cabling physically possible.

The system works by first initializing the RFID IC (TRF7960A) upon power up. Antenna 1 (on Antenna Board 1) is (by default) selected. The host would then issue a series of commands to: 1. Turn on the RFID IC transmitter, 2. Issue a single slot ISO/IEC15693 Inventory Command, 3. Receive a response from the transponder in the field (if one was present), 4. Turn off the transmitter, and then 5. Switch to the next antenna and then repeat steps 1-5 until all sixteen antennas in the system are addressed and the transponders in their respective fields are read. These steps are described in much greater detail later in the document and a flow chart is also provided in this document to clearly illustrate/outline the example application usage process.

2 System Hardware

2.1 RFID Controller Board

The RFID Controller board main components consist of one TRF7960A RFID IC, one MSP430F2370 microcontroller, one SN65176D RS-485 transceiver, two MAX3232E RS-232 driver/receivers and an REG117-5 (+5VDC, 800mA) linear regulator. The MSP430 holds the firmware required to communicate with the host via its UART channel and initialize/communicate with the TRF7960A via its SPI channel. The MSP430 firmware also takes properly formatted commands from the host and controls the RF switches located on the antenna boards via its GPIO ports, then reports the results back to the host via the UART channel. The linear regulator takes the +9VDC to +12VDC from the power supply and down converts this voltage to +5VDC for the TRF7960A to operate at full power. The TRF7960A provides +3.3VDC (via VDD_X) and a 6.78MHz system clock (via SYS_CLK) to the MSP430 for high speed operation. The TRF7960A also provides +3.3VDC to the RF switches via VDD_X. One of the RS-232 driver/receivers is for direct host (i.e. PC) RS-232 communications with the MSP430 (UART side). The second RS-232 driver/receiver is connected to the first RS-232 driver transceiver (DB9 side) and the RS-485 transceiver to create a simple RS-485 to RS-232 converter and to simplify the connection to the MSP430F2370. Minor components consist of one 18 position Micro Mate-N-Lok connector, one RJ-45 connector, one SMA connector, one DB9 connector (optionally populated for TI testing), a power connector, along with the required passive and active components necessary for proper power supply filtering, impedance matching, and charge pump voltage generation of the circuits on the board. A full schematic and layout of the RFID Controller board is shown later in this document. Datasheets for the components mentioned above can be found in the references section.

2.2 RFID Antenna Board

The RFID Antenna board main components consist of 4 PCB trace loop antennas (tuned for 13.56MHz, $Q < 20$), one Peregrine Semiconductor PE42440 SP4T RF switch and one Peregrine Semiconductor PE4257 SPDT RF switch. The minor components on the board are two 18 position Micro Mate-N-Lok (for GPIO/+3.3VDC in and GPIO/+3.3VDC feed through to next antenna board), two SMA connectors (for RF in and RF out to next antenna board). There are four of these boards (total) in the system. A full schematic and layout of the RFID Antenna board is shown later in this document. Datasheets for the components mentioned above can be found in the references section.

2.3 System Cables & Connections

2.3.1 Host Communication

Host communication is achieved via either RS-232 or RS-485. RS232 cable should be pinned out according to industry standard for DCE to DTE. (RS-232 DB9 pins 2, 3 and 5.) RS-485 cable is a custom, non standard implementation using CAT5 cable. (Using TX/RX_1, TX/RX_2 and RTS)

2.3.2 Power Cable

Custom power cable is required for delivering +12VDC to RFID Controller board.

2.3.3 RF Cables

Industry standard 50Ω coaxial cables with SMA plugs on both ends are required for this system. RG-316 is recommended cable type.

2.3.4 GPIO/+3.3VDC Cables

GPIO cables to be used in this system are terminated into 18 position Micro Mate-N-Lok connectors. These wires in these cables are terminated with receptacle contacts for mating to Micro Mate-N-Lok board header.

2.4 ISO/IEC15693 Transponder

The requirement for this system was for ISO15693 compliant transponder with 2048 or 256 bits of user memory. The Texas Instruments transponder and inlay offerings fit exactly this requirement and are what is used in this application. Datasheet for this component mentioned above can be found in the references section.

3 System Firmware

MSP430F2370 firmware used for this project is based on TRF7960A EVM firmware (hyperlink found in references section of this document). This firmware project which is provided (now named `_MUX_TRF7960A`) has been modified specifically for use in this application to support extended GPIO port control of up to 16 antennas and exclude (but not remove support for) the other ISO protocols. The firmware has also been modified to return the unique identifier (UID) of the transponder as one would read it (versus the way it is returned over the air). For example, the transponder UID is returned over the air LSByte first, so then the firmware file `uart.c` was modified to manipulate the returned UID so that any host controller software is relieved of this task. (i.e. UID is now returned to the host as E00781BCC1912470 versus 702491C1BC8107E0).

3.1 MSP430F2370 Setup

The MSP430F2370 firmware initializes the TRF7960A RFID Reader IC and configures it for ISO/IEC15693 operation using the default settings for the IC. (Full power out (+23dBm), High Transponder Data Rate (26.4kbps) and 1 of 4 data coding).

3.2 ISO/IEC15693 Support

The MSP430F2370 firmware provided does support all ISO15693 commands currently known to be relevant to this project and allows for all mandatory and optional commands listed in the standard which may not apply to this project currently, but could be used later.

3.3 GPIO Control

The firmware provides support for the hardware to control up to 16 antennas via the GPIO available on the MSP430F2370 directly driving the control lines on the PE42440 and PE4257 RF switch ICs used on the antenna boards. One PE42440 switch and one PE4257 switch are mounted on each antenna board to accommodate the four PCB trace antennas and provide for output to next antenna board. The PE42440 and PE4257 switch functional diagrams and truth tables are shown below (Figures 2 and 3) for reference. Table 1 is the combined (PE42440 + PE4257, as connected on each antenna board) truth table. Figure 4 shows the block diagram of this circuit arrangement. These simple details about the switches and the circuit arrangement are important to understand before looking at entire system arrangement.

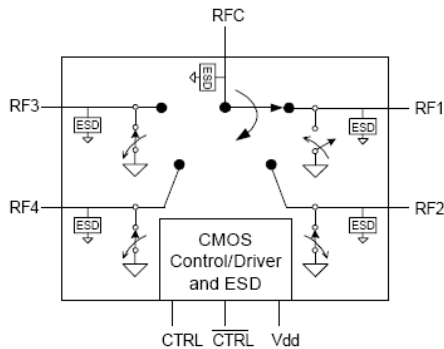

Path	V2	V1
RFC – RF1	0	0
RFC – RF2	1	0
RFC – RF3	0	1
RFC – RF4	1	1

Figure 2. PE42440 Functional Diagram and Truth Table

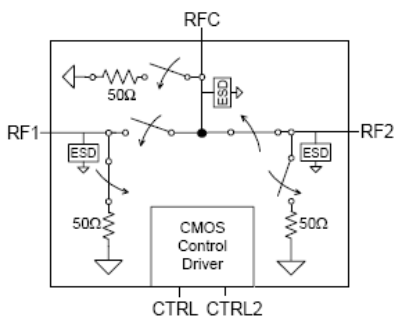

CTRL1	CTRL2	RFC – RF1	RFC – RF2
Low	Low	OFF	OFF
Low	High	OFF	ON
High	Low	ON	OFF
High	High	N/A ¹	N/A ¹

Figure 3. PE4257 Functional Diagram and Truth Table

RF Switch(es) Used	Channel(s) Used	PCB Antenna / Switch Port Selected	Notes
PE42440	RFC → RF1	1	Default on power up
PE42440	RFC → RF2	2	
PE42440	RFC → RF4	3	
PE42440	RFC → RF3	To PE4257 RFC	For antenna 4 or RF OUT
PE42440 + PE4257	RFC → RF2 (PE4257)	4	
PE42440 + PE4257	RFC → RF1 (PE4257)	RF OUT	To next antenna board

Table 1. TRF7960A Multiplexer Antenna Truth Table (one board)

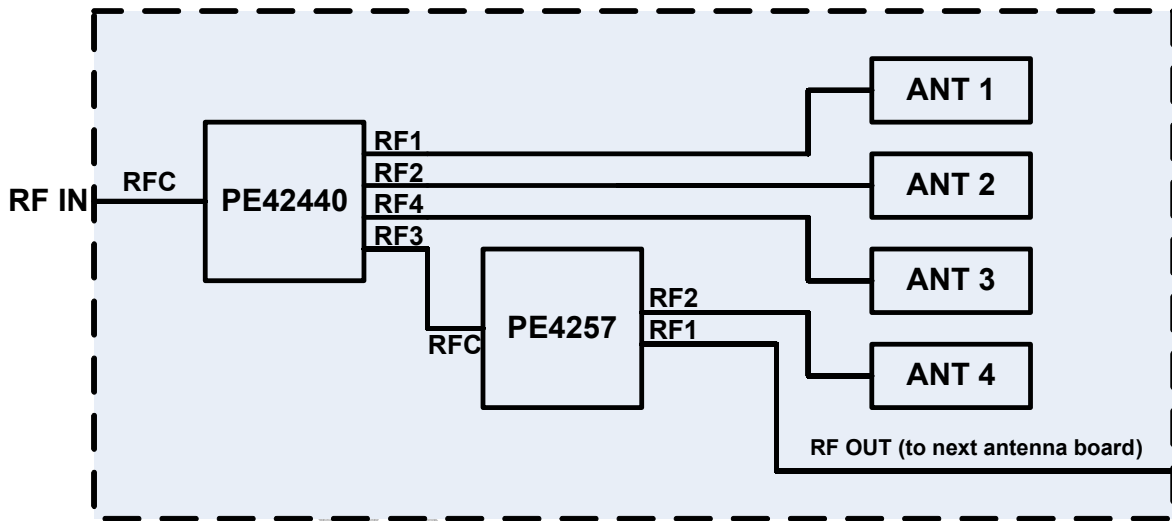

Figure 4. PE42440 and PE4257 Antenna Circuit Arrangement Detail Diagram

The full switch logic matrix is shown below in Table 2 and can be viewed in the firmware by opening the msp430f23x0.h file where they are defined and the host.c file where they are called (using 0xC0:0xCF and 0xD0:0xDF host commands).

Table 2. MSP430 GPIO Switch Logic Matrix (full system)

ANTENNA BOARD	1				2				3				4		
GPIO USED	P4.6	P4.5	P4.3	P4.4	P4.2	P4.1	P3.7	P4.0	P1.7	P1.6	P1.4	P1.5	P1.3	P1.2	P1.1
ANTENNA	V2	V1	CTRL1	CTRL2	V2	V1	CTRL1	CTRL2	V2	V1	CTRL1	CTRL2	V2	V1	CTRL1
1	0	0	0	0	0	0	0	0	0	0	0	0	0	0	0
2	1	0	0	0	0	0	0	0	0	0	0	0	0	0	0
3	1	1	0	0	0	0	0	0	0	0	0	0	0	0	0
4	0	1	1	0	0	0	0	0	0	0	0	0	0	0	0
5	0	1	0	1	0	0	0	0	0	0	0	0	0	0	0
6	0	1	0	1	1	0	0	0	0	0	0	0	0	0	0
7	0	1	0	1	1	1	0	0	0	0	0	0	0	0	0
8	0	1	0	1	0	1	1	0	0	0	0	0	0	0	0
9	0	1	0	1	0	1	0	1	0	0	0	0	0	0	0
10	0	1	0	1	0	1	0	1	1	0	0	0	0	0	0
11	0	1	0	1	0	1	0	1	1	1	0	0	0	0	0
12	0	1	0	1	0	1	0	1	0	1	1	0	0	0	0
13	0	1	0	1	0	1	0	1	0	1	0	1	0	0	0
14	0	1	0	1	0	1	0	1	0	1	0	1	1	0	0
15	0	1	0	1	0	1	0	1	0	1	0	1	1	1	0
16	0	1	0	1	0	1	0	1	0	1	0	1	0	1	1

In the table above (Table 2), the green shaded blocks follow the 13.56MHz signal path through the system and show the antenna selected as well as the GPIO used in the process. Table 3 below shows the Host Command Codes used to turn on/off the antennas. The complete Host Command format is explained in Section 4.

Table 3. Host Command Codes for Antenna Selection

Antenna Number	Command Codes (on / off)
1	N/A (DEFAULT ANT)
2	0xC0 / 0xC1
3	0xC2 / 0xC3
4	0xC4 / 0xC5
5	0xC6 / 0xC7
6	0xC8 / 0xC9
7	0xCA / 0xCB
8	0xCC / 0xCD
9	0xCE / 0xCF
10	0xD0 / 0xD1
11	0xD2 / 0xD3
12	0xD4 / 0xD5
13	0xD6 / 0xD7
14	0xD8 / 0xD9
15	0xDA / 0xDB
16	0xDC / 0xDD

4 System Host Commands

The System Host Commands provide the method by which the RFID Controller board is communicated with. As named, the Host Controller in the system (i.e. PC, etc.) will send specifically formatted commands as defined below to accomplish a task and the MSP430F2370 firmware on the RFID Controller board will echo back the command sent, along with the data relevant to that command. (i.e. Unique ID with RSSI value, Transponder Block Data, etc.)

4.1 Host Commands Structure Definition

The Host Commands have a general protocol structure as defined below in Figure 5.

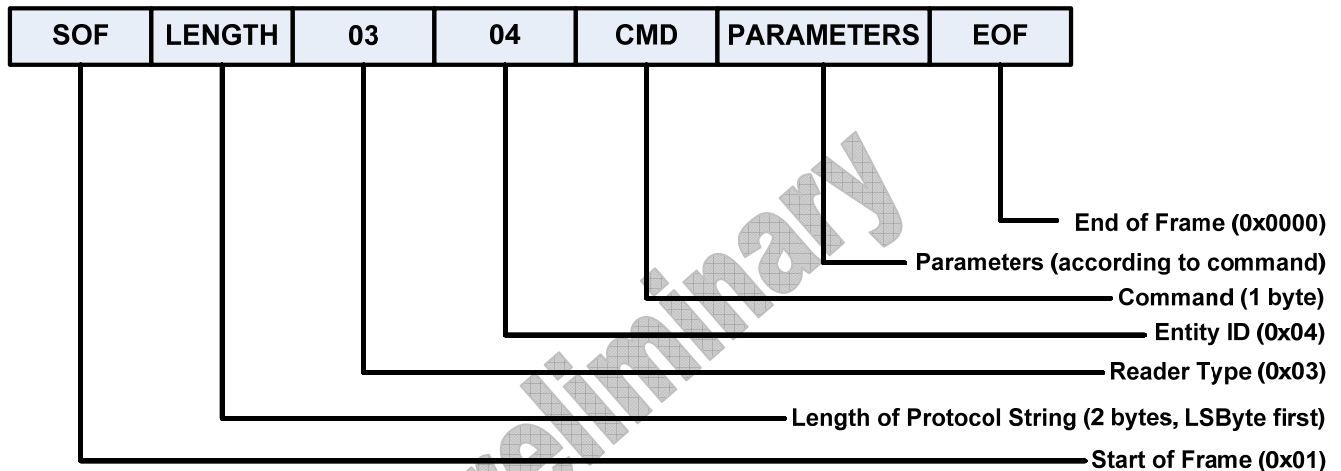

Figure 5. RFID Controller Host Protocol General Format

For the simplification purposes/brevity of this system document, the Host Commands are fixed examples and should be used as outlined/explained in the sub-sections below. For further reading on the other Host Commands possible with the ISO/IEC15693 protocol supported by this firmware, a hyperlink to the application note entitled TRF7960EVM Host Commands can be found in the References section of this document.

4.2 Initiate Communication with RFID Controller Board

To initiate communication with the RFID Controller board firmware from the Host Terminal, the following command should be sent:

0108000304FF0000, where **FF** is the command, with no parameters being sent.

The controller board will echo back this command string, followed by text string in ASCII of:

```
TRF7960A_MUX_RFID
****COM Port found! ****
```

4.3 Set Protocol

The set protocol command is issued to configure the TRF7960A reader IC for operation with the ISO/IEC15693 standard based transponders. In the ISO/IEC15693 standard, there are multiple settings for this allowed. For best performance, the command string example used here in this document will be for TRF7960A operating with +5VDC, full power out (+23dBm), 100% modulation depth on the downlink with ISO15693 high transponder data rate (26.48kbps) with single subcarrier transponder response and 1 of 4 data coding used/expected back on the uplink. This is a register write request to the TRF7960A Chip Status Control and the ISO Control Registers. (Registers 0x00 and 0x01) The command string example used here to be sent from a Host Terminal would be:

010C000304**1000210102**0000, where **10** is the command and **00210102** are the parameters.

This string will be echoed back from the RFID Controller Board, followed by the ASCII string:
Register Write Request.

4.4 Inventory Command

The Inventory Command is used by the TRF7960A to retrieve the unique ID (UID) from the transponder. The command string example used here (Single Slot Inventory) to be sent from a Host Terminal would be:

010B000304**14260100**0000, where **10** is the command and **002100** are the parameters.

This string will be echoed back from the RFID Controller Board, followed by the ASCII string:
ISO 15693 Inventory request.

And then the UID will be sent back to the host along with an RSSI (Received Signal Strength Indicator) value (which indicates relatively how close the transponder is to the energizing antenna):

[UID,RSSI]

For example, [E00781BCC1912470,77]; where E00781BCC1912470 is the UID (for this transponder in the field) and 77 is the RSSI value (as the transponder is very close to the antenna. The RSSI values can range from 0x40 to 0x7F.

4.5 Turn off RF Transmitter

Turning off the transmitter before switching channels is a recommended practice in any RF application as it reduces the amount of stress on the switch or relay in a given system, providing for a potentially longer service life. This is a register write request to the TRF7960A Chip Status Control Register (Register 0x00) and more specifically a toggle of bit 5 in that register. The command string example used here to be sent from a Host Terminal would be:

010A000304**100001**0000, where **10** is the command and **0001** are the parameters.

This string will be echoed back from the RFID Controller Board, followed by the ASCII string:
Register Write Request.

4.6 Switch Antenna

Switching antennas is the main feature highlight of this system. The MSP430 firmware has been modified (as explained in previously in this document) to allow the host to choose any of the sixteen antennas in the system by using the host commands shown in Table 3 and outlined in Table 2. The command string example used here to be sent from a Host Terminal would be:

0108000304C00000, where C0 is the command, with no parameters being sent.

This string will be echoed back from the RFID Controller Board, followed by the ASCII string:

Switch 2 On.

The other “Switch Antenna” commands are shown in Table 3 and will have similar messaging in ASCII corresponding to the operation performed. For example, sending 0108000304C10000 results in that string being echoed back, followed by the ASCII string: Switch 2 Off.

4.7 Turn on RF Transmitter

The transmitter of the TRF7960A RFID IC must be turned on prior to issuing any commands to transponders in the field. Otherwise, they will not be energized and will not respond. This is a register write request to the TRF7960A Chip Status Control Register (0x00) and more specifically a toggle of bit 5 in that register. The command string example used here to be sent from a Host Terminal would be:

010A0003041000210000, where 10 is the command and 0021 are the parameters.

This string will be echoed back from the RFID Controller Board, followed by the ASCII string:

Register Write Request.

4.8 Read Transponder Data Block(s)

The Read Single Block Command is used by the TRF7960A to retrieve the transponder memory data preprogrammed onto the transponder. The command string example used here to be sent from a Host Terminal would be:

010B000304180220000000, where 18 is the command and 022000 are the parameters. 02 are the request flags for the command, 20 is the Read Single Block command, and 00 is the block # to be read (in this example) (block range with this transponder is from 0x00 to 0x3F)

This string will be echoed back from the RFID Controller Board, and if read was successful, it will be followed by:

[0078563412], where 78563412 is the transponder memory block data (in this example), note that the data is returned MSByte first and the 00 in the return indicates ‘no error’. Data in block could be programmed to any value between 0x00000000 to 0xFFFFFFFF.

4.9 Write Transponder Data Block

The Write Single Block Command is used by the TRF7960A to write data (program) to the transponder memory. The command string example used here to be sent from a Host Terminal would be:

010F000304**1842210078563412**0000, where **18** is the command and **42210078563412** are the parameters. 42 are the request flags for the write operation, 21 is the Write Single Block command, and 00 is the block to be written (in this example). 78563412 is the data block to be written (in this example). User memory (data blocks) range on the transponder being used is from 0x00 to 0x3F. Data can be any value desired in hexadecimal format (from 0x00000000 to 0xFFFFFFFF). Note this block data is sent MSByte first.

This string will be echoed back from the RFID Controller Board, and if write was successful, it will be followed by the ASCII string:

Request mode.

And then the Error Flags will be returned in the following manner:

[00], where 0x00 equals no error (write operation was successful)

Other possible responses here are:

[0103] = Option not supported (option flag not set, should be set for TI tags (0x42)

[010F] = Unknown error

[0110] = Block not available (memory block range is 0x00 to 0x3F)

[0113] = Programming was not successful (memory block could be locked or too far away)

4.10 Example Application Usage Flow Chart

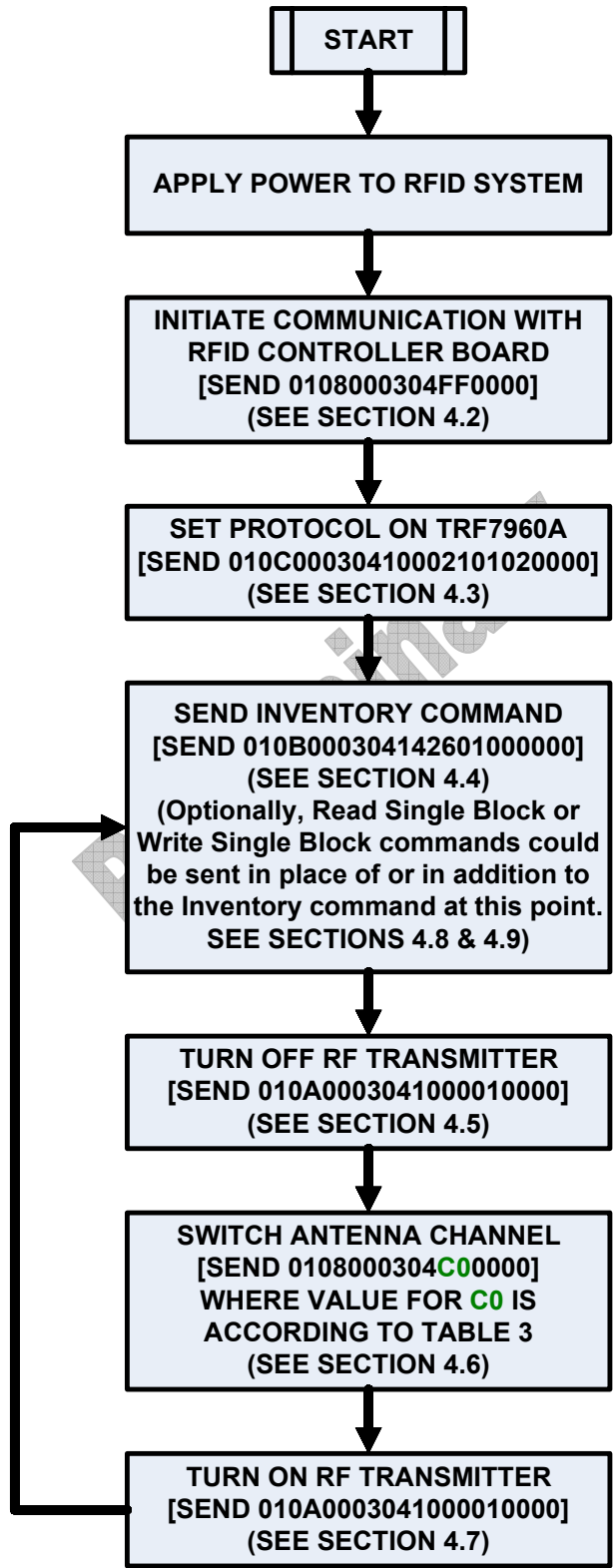

5 Performance Measurements/Testing

In antenna multiplexing/switching applications such as this example, close attention should always be paid to the potential of RF signal loss and crosstalk between channels. Switches chosen have a 50Ω characteristic impedance, are made for the frequency of operation (in this case 13.56MHz), be able to handle more than the maximum output power level possible from the transmitter (in this case +23dBm/200mW) and have good isolation between channels. In this reference design, the Peregrine Semiconductor devices PE42440 and PE4257 were used and meet these criteria. These were lab tested with TRF7960A EVM, PE42440 and PE4257 EVMs. Loss measured was within expected levels as the PE42440 and PE4257 data sheets indicate that 0.45dBm and 0.7dBm loss should be expected from these parts, respectively. RF-HDT-DVBB read range was also checked here with the different power out levels with same antenna 6.5cm diameter coils. Read range was minimally affected, where observed read range varied about 0.25cm. Figures 6, 7 and 8 show the spectrum analyzer captures for the bench top, hand wired prototype. These same tests will be repeated when actual system is built.

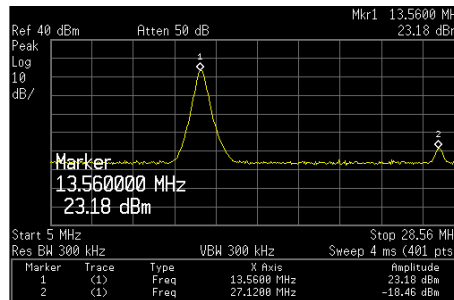

Figure 6. TRF7960A Out (~+23dBm)

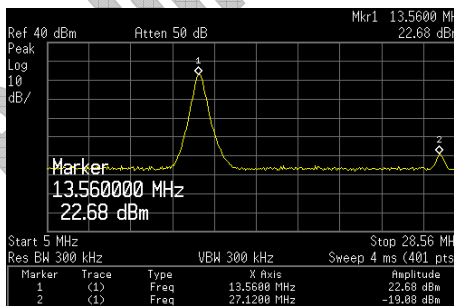

Figure 7. TRF7960A to PE42440 Out (~0.5dBm loss)

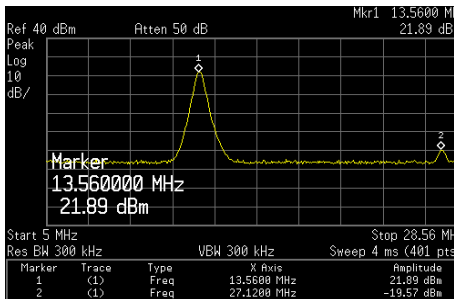

Figure 8. TRF7960A to PE42440 to PE4257 out (~0.8dBm loss)

Code

Firmware code project (in CCS) and compiled binary image file (TRF7960A_MUX.out) will be provided in separate zip file called: TRF7960A_MUX.zip

References

1. <http://www.ti.com/lit/ds/symlink/msp430f2370.pdf> (MSP430F2370 Data Sheet)
2. <http://www.ti.com/lit/ds/symlink/trf7960a.pdf> (TRF7960A Data Sheet)
3. <http://www.ti.com/litv/zip/sloc251> (TRF7960A MSP430F2370 Base Firmware Example)
4. <http://www.ti.com/lit/an/sloa141/sloa141.pdf> (TRF7960A ISO15693 Host Commands)
5. <http://www.ti.com/lit/gpn/max3232e> (MAX3232E RS-232 Line Driver/Receiver)
6. <http://www.ti.com/lit/ds/symlink/sn65176b.pdf> (RS-485 Transceiver Data Sheet)
7. <http://www.ti.com/lit/gpn/reg1117-5> (REG1117-5 +5VDC 800mA Linear Regulator)
8. <http://www.psemi.com/content/products/switches/PE42440.html> (PE42440 Data Sheet)
9. <http://www.psemi.com/pdf/datasheets/pe4257ds.pdf> (PE4257 Data Sheet)
10. <http://www.ti.com/lit/ds/symlink/rf-hdt-dvbb.pdf> (2kbit ISO15693 Encapsulated Transponder)
11. ISO/IEC15693-2, -3 Standard

Preliminary

Appendix A. Schematics

See PDF

Figure 9. RFID Controller Board

See PDF

Figure 10. RFID Controller Board

See PDF

Figure 11. Antenna Board

Preliminary

Appendix B. Layout Images

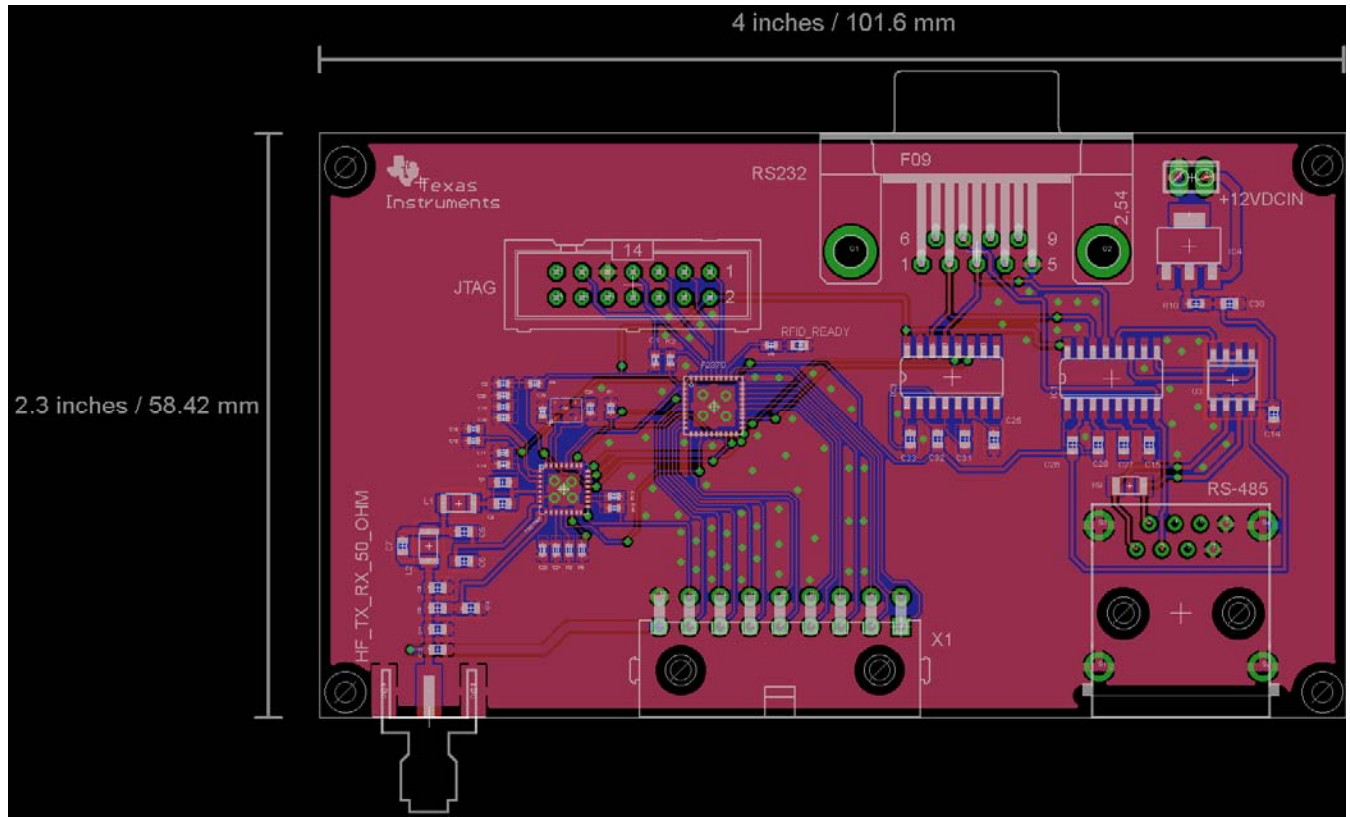

Figure 12. RFID Controller Board Layout

The dimensions of this board are 4.00 inches x 2.3inches (101.6mm x 58.42mm). Original customer requirement was that this board be no larger than 110mm x 220mm. Mounting holes are M4.

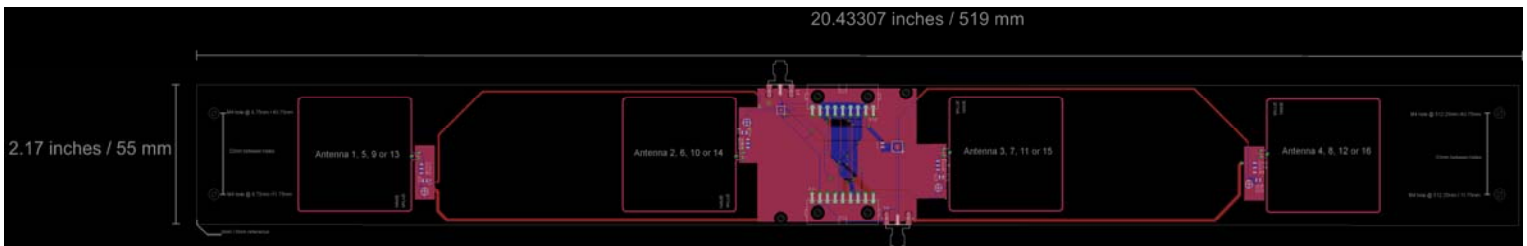

Figure 13. RFID Antenna Board Layout

The dimensions of this board are 20.433 inches x 2.17 inches (519 mm x 55mm). Per original customer specification, two M4 size mounting holes are provided on either end of this board, spaced 6.75mm from the board edge and 32mm apart from each other vertically. With respect to the mounting hole spacing from each other horizontally, they are spaced 505.5mm from each other, again, per original customer specification.

Appendix C. Cable Details

The system boards are designed with simplification of the cabling scheme in mind. Figure 14 (below) shows the cascade concept for the signal flow from the controller board out to the first antenna array board, then from the first antenna array board to the second, and so on to the last antenna array board. The GPIO signals as well as the RF signals are cascaded through the boards as shown while the +3.3VDC and Ground are provided to each board directly. Figure 15 shows this in greater detail.

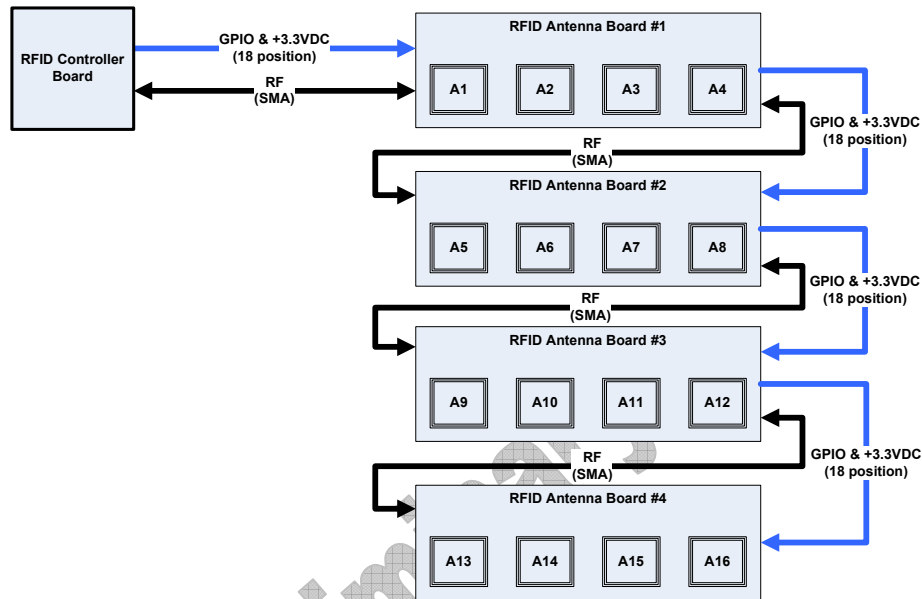

Figure 14. Signal Cascade Concept

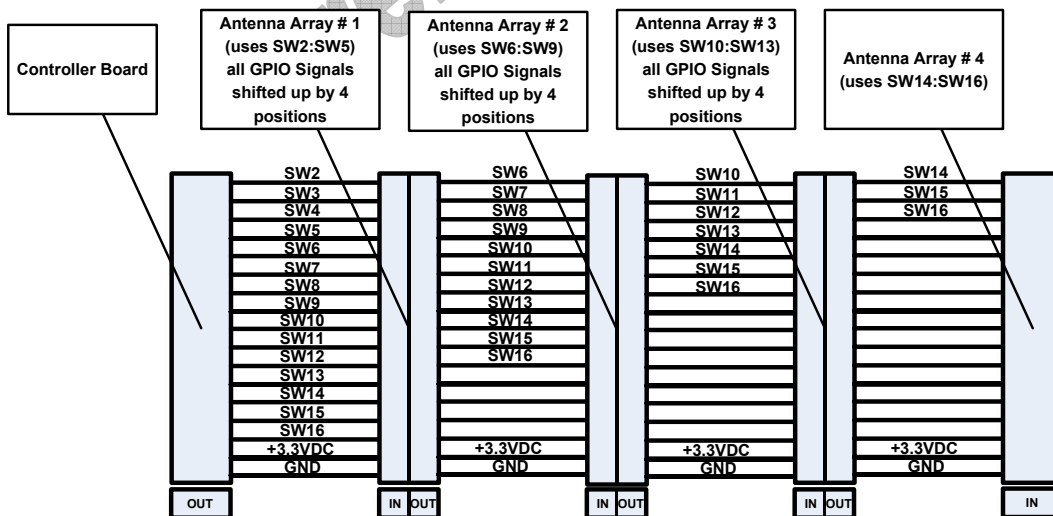

Figure 15. Cabling for Signal Cascade Concept

Table 4 (below) shows the cable pin out of the signal distribution illustrated in Figure 15 for clarity and understanding. This cabling approach allows for one cable assembly to be created and then replicated four times for the system which will accommodate and distribute all the signals required for command and control. Examination of the schematics and Figure 15 show that the cabling between the controller board and the antennas can all be the same since the signal routing and shifting occurs on the boards.

Table 4. GPIO Cable Pin Out

Pin	Name	Function
1	SW2 / SW6 / SW10 / SW14	SW2 from controller to first antenna board, SW6 for second antenna board, SW10 for third antenna board, SW14 for fourth antenna board
2	SW3 / SW7 / SW11 / SW15	SW3 from controller to first antenna board, SW7 for second antenna board, SW11 for third antenna board, SW15 for fourth antenna board
3	SW4 / SW8 / SW12 / SW16	SW4 from controller to first antenna board, SW8 for second antenna board, SW12 for third antenna board, SW16 for fourth antenna board
4	SW5 / SW9 / SW13	SW5, SW9 and SW13 from controller to first antenna board for further routing
5	SW6 / SW10 / SW14	SW6, SW10 and SW14 from controller to first antenna board for further routing
6	SW7 / SW11 / SW15	SW7, SW11 and SW15 from controller to first antenna board for further routing
7	SW8 / SW12 / SW16	SW8, SW12 and SW13 from controller to first antenna board for further routing
8	SW9 / SW13	SW9 and SW13 from controller to first antenna board for further routing
9	SW10 / SW14	SW10 and SW14 from controller to first antenna board for further routing
10	SW11 / SW15	SW11 and SW15 from controller to first antenna board for further routing
11	SW12 / SW16	SW12 and SW16 from controller to first antenna board for further routing
12	SW13	SW13 from controller to first antenna board for further routing
13	SW14	SW14 from controller to first antenna board for further routing
14	SW15	SW15 from controller to first antenna board for further routing
15	SW16	SW16 from controller to first antenna board for further routing
16	VDD_X (+3.3VDC)	Voltage Supply for Digital Switches
17	RF_OUT/RF_IN (50_OHM)	RF (Coaxial or Twisted Pair) (optional, usage based on testing)
18	GND	GND (Coaxial or Twisted Pair)

The preliminary cable assembly diagram is shown below in Figure 16.

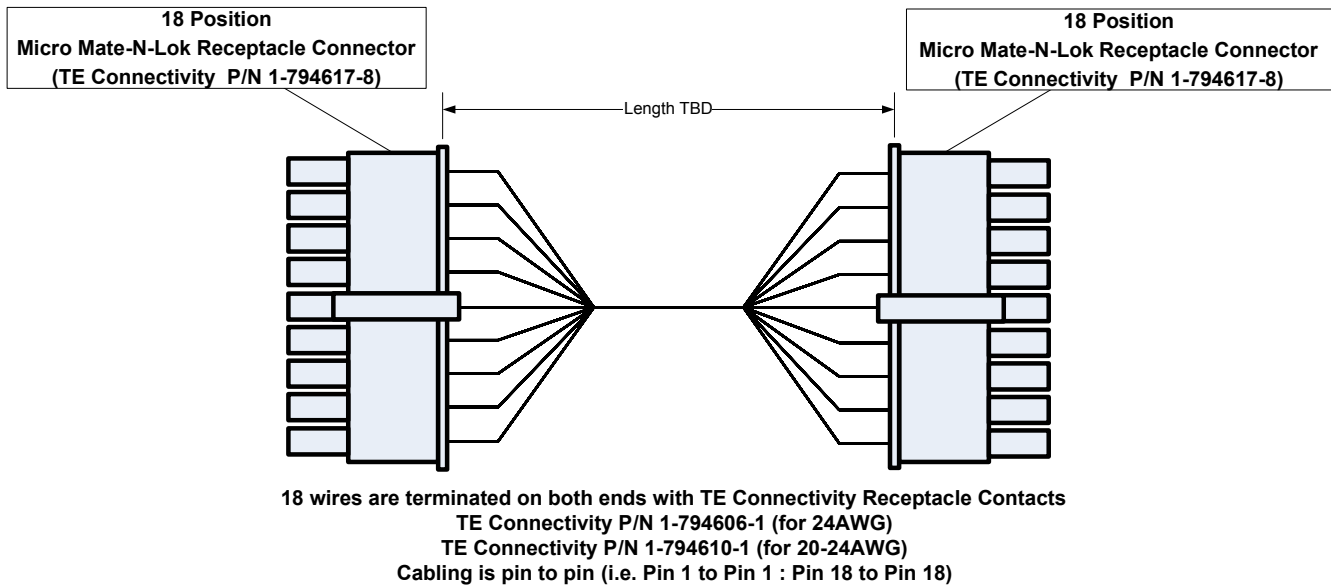

Figure 16. GPIO Cable Diagram

Preliminary