

# Design for Easy Access to Buildings by Physically Disabled Persons

by Lars Reuterswård



Lars Reuterswård was born in Sweden in 1949. He became a Master of Architecture in 1974 and earned the degree *Teknologie doktor* in 1984 with a dissertation on the evaluation of building. He was appointed Professor of Architecture and Development Studies at Lund Institute of Technology, Lund University in 1986.

He has worked in a private architectural practice, as research officer at the Swedish Council for Research Cooperation with Developing Countries (SAREC), and as construction adviser in Vietnam for the International Red Cross and UNICEF. He is active in preparations for international meetings, such as *Habitat II*, and is chairman of *Konstföreningen Aura*, an association of artists that arranges exhibitions at their own gallery in Lund.

## Contents

---

1	Introduction	4
	Problem	4
	Method	4
	Organization of the Report	4
2	General Considerations	5
	Physical Disabilities	5
	Design Guidelines	5
3	Recommendations	6
	Designing for People with Difficulties in Moving	6
	Openings and Thresholds	6
	Verandas and Corridors	7
	Kerbs	7
	Ramps	7
	Stairs	9
	Lifts	9
	Layout	9
	Lavatories	9
	Designing for People with Difficulties in Seeing	10
	Glare	10
	Use of Colour	10
	Designing for People with Difficulties in Hearing	11
	Acoustics	11
4	Check List for Barrier-Free Design	12
	Bibliography	14

# 1 Introduction

## Problem

In developing countries more than one person in ten has a physical or sensory impairment. However, only when an impairment prevents an individual from fulfilling a “normal” role in society, does he or she become “handicapped.”

There is a tendency to focus on the *disabilities* of impaired persons, such as their moving, seeing or hearing difficulties. It is however a valid argument that one should think instead of their *abilities*. The integration of the impaired into society gives both social and an economic gains, and it also promotes social equity.

The aim of this Building Issue is to make fewer individuals handicapped, by making the physical environment more accessible and supportive. It will show how *many barriers can be avoided*.

The report will identify *basic requirements for barrier-free design*, and offer some *design guidelines*.

These are intended to be valid for most kinds of low to medium cost buildings and their sites. However, it is of particular importance that they are applied to *all institutional* buildings, that is not only to buildings specifically intended for use by disabled. This is because an individual is confined to an incomplete social role, if she cannot enter a school building, a clinic, a local government administration office, or the like.

Buildings can be made more accessible to disabled persons *at little or no extra cost*, provided that the issue is considered at the planning stage. It is invariably more expensive to reduce barriers in an existing building, than to include such qualities from the beginning.

Many institutional buildings are built by central and local government agencies with their own resources, or with external support. A wise client includes non-handicapping performance specifications in the architect’s brief (or the equivalent), before approving the project. This is primarily a question of attitudes and of information. It is for the client to request a reasonably barrier-free building. Performance specifications to this effect should be taken into account by the architect and the builder.

## Method

This is a desk study. It is based primarily on UNESCO’s *Handbook on Design Guidelines for Easy Access to Educational Buildings by Physically Handicapped Persons*, by Lars Reuterswård. The handbook follows the format and reprints parts of *Designing With Care – a Guide to Adaptation of the Built Environment for Disabled Persons*. The guide was developed for the United Nations in conjunction with the International Year of Disabled Persons (1981), and has a clear developing country perspective. For this reason the *advice and dimensional recommendations presented in this Building Issue are based on those of the UN guide*, whenever applicable.

## Organization of the Report

Chapter 1 describes the problem and the method of the study. Chapter 2 contains general considerations for appropriate building design for the physically disabled, and defines what is meant by impairment, disability and handicap. Chapter 3 consists of concrete and illustrated design guidelines and recommendations for creating a non-handicapping physical environment at no or low extra cost. These recommendations are related to moving, seeing and hearing difficulties. Chapter 4 is a check list intended as a reference for the client when developing the architect’s brief, and later when approving the project. The check list amalgamates basic properties needed to mitigate the handicapping consequences of physical disabilities.

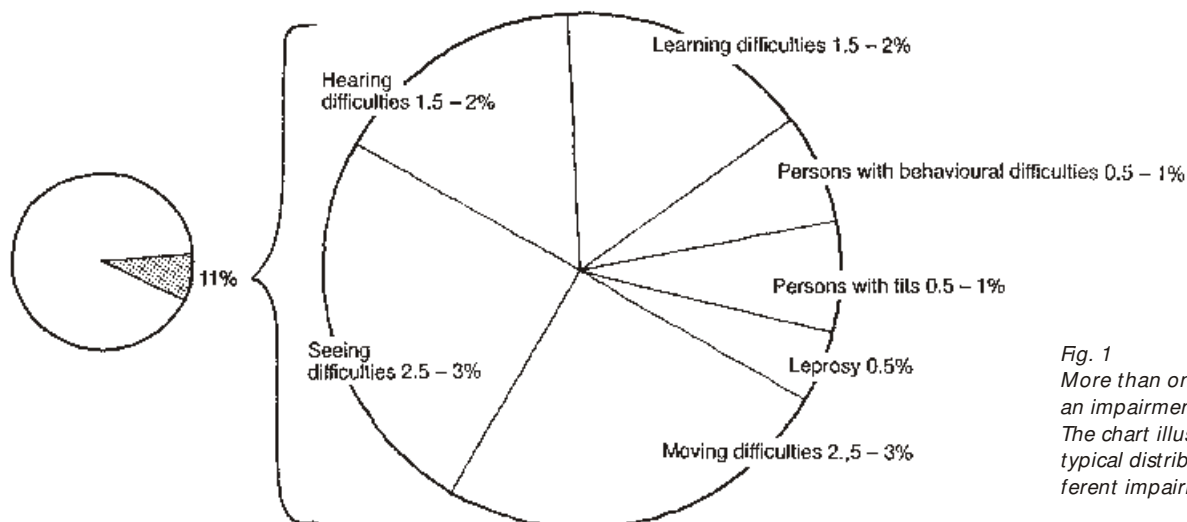

Fig. 1  
More than one in ten has an impairment.  
The chart illustrates the typical distribution of different impairments.

## 2 General Considerations

The World Health Organisation makes a distinction between the concepts of *impairment*, *disability* and *handicap*:

- an *impairment* is a damage, illness, etc.
- a *disability* is a reduction in a person's capacity, as the consequence of an impairment
- a *handicap* is the limitation, caused by the impairment and disability, to her in her daily life.

A handicap is thus not primarily related to the properties of a person. A disabled person becomes handicapped when physical or societal conditions prevent her from leading a normal life. An *accessible environment* means that persons with disabilities are not unduly excluded from using it. To design for easy access means to reduce the number of persons that are handicapped.

The focus of this Issue is almost exclusively on design solutions that could be employed at small or no cost to the client. Above and beyond these, there are many more ways of further eliminating barriers for the disabled. These are not included here, since they are covered in the general literature. They are usually more costly and sometimes require the use of sophisticated equipment, such as elevators.

The design recommendations and measures suggested here are *general guidelines*. There are however considerable differences in average body sizes and proportions of individuals between countries. The designer is well advised to adjust for local anthropometric standards.

Only *physical disabilities* are covered. These are clearly related to the built environment. A building accessible for persons with physical disabilities will generally be supportive also for those with other kinds of disabilities, and indeed for persons without impairments.

### Physical Disabilities

There are several categories of physically disabled persons. The main are those with difficulties related to moving, seeing, hearing and/or speaking.

The group with moving difficulties benefits the most from barrier-free design – both in and around buildings. In this group a distinction can be made between the persons who use a *wheelchair* or similar, and those who are *ambulant* but might use walking aids or other supports.

- The disabled, confined to *wheelchairs or similar*, need to be able to approach the building and move about inside it freely. The chair needs adequate space for manoeuvring. Steps should not obstruct it. The disabled should be able to manage cloakroom and lavatory without help. There is also a need for ramps, as an alternative to stairs, for vertical transfer.
- The situation for *ambulant* persons is different. They might be unsteady and cannot walk long distances. They are dependant on adequate space and of extra support, such as handrails, and of resting places. Many of them prefer steps, in contrast to those in wheel-

chairs, as there is a risk of overbalancing when descending a ramp.

There are many ambulant persons with seeing difficulties who have problems with orientation and mobility. They generally benefit from conscious light and colour treatment, as well as a logical building design and layout, and easily read signs. Safety is important.

Persons with hearing and/or speaking difficulties need acoustically well designed and quiet spaces, as well as good lighting for lip reading.

### Design Guidelines

Architectural design alone cannot provide for an uncompromising independence for all disabled. Architectural design is best suited to alleviate difficulties experienced by those with **moving** difficulties, followed by those with **seeing** and **hearing or speaking** difficulties. Site planning and building design should respect these disabilities and recognise the performance properties that the product shall meet.

It is crucial to remember that designs and proposals in this report are general. This is to say that they should not only be linked to buildings specifically intended for persons with disabilities, but ideally to all buildings and the built environment at large. It is indeed a challenge to make buildings both accessible and beautiful for all – at moderate or no extra cost!

There is a wealth of literature on the subject. In many cases the recommendations are quite sophisticated and applicable primarily to high-cost building projects. Literature on handicap issues and (institutional) buildings is indicated in the bibliography.

In the process of selecting what to include in this Building Issue, recommendations, designs, and equipment that are complicated, costly or of marginal importance, have been excluded. Only what can be considered as basic requirements to achieve a reasonably barrier-free built environment have been included.

### 3 Recommendations

#### Designing for People with Difficulties in Moving

The design for people with moving disabilities is related to making the environment accessible to people confined to wheelchairs (or similar) and ambulant people using other walking aids.

To people using **wheelchairs** the dimensions and characteristics of these are essential for making the environment barrier free. The **length** of conventional wheelchairs is 1100–1200 mm and the **width** 600–700 mm. The **manoeuvring** space needed for wheelchair turning is a circle of 1500 mm diameter (Figure 3).

The **reach** of persons in a wheelchair is restricted to a zone less than 400 mm from room corners and between 700 and 1200 mm above the floor. These measurements are based on a wheelchair design widely used by those who can afford it. Simpler designs are however frequently used in some countries. A common model has small wheels and is a rudimentary rolling board. Manoeuvring space requirements will be the same or less. However, the height of reach is 300–400 mm less than with conventional wheelchairs. To suit all kinds of wheelchairs, rolling boards and ambulant persons, switches and other *implements should thus be placed at a height of 900 mm and at least 400 mm from inside corners.*

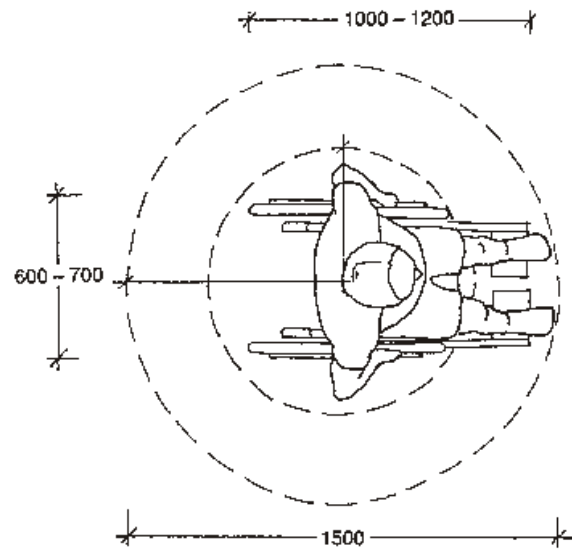

Fig. 3 Floor space needed for manoeuvring a wheelchair.

#### Openings and Thresholds

A **door** should have a clear opening of at least 800 and preferably 900 mm for a wheelchair to pass. There should be a space of at least 300 mm on the wall next to the door handle for easier approach.

Doors should not open into corridors or other areas where people may walk into them, unless fire regulations so require. If so, doors should open 180° so that they can be put against the wall and out of the way. Adequate space should be provided for in front of doors to allow for manoeuvring of wheelchairs. Attention should be paid as to how doors are hung, and on the direction of opening. Doors in toilets or other small spaces should open outwards so that a person falling in the room will not block the door.

Doors should not be difficult to open. Lever handles are preferred to knob handles because levers can be used with one or more fingers only. A vertical pull handle at approximately 900 mm from the floor level is easy to operate.

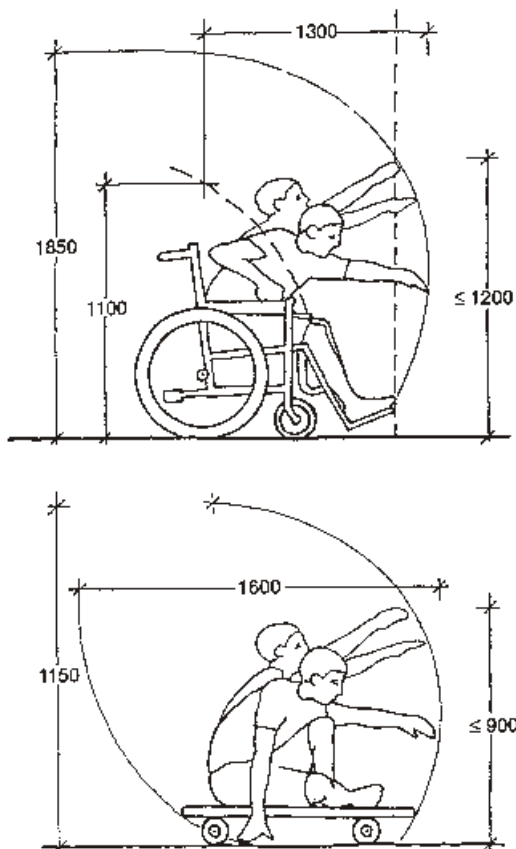

Fig. 2 Ranges of reach for adults in wheelchairs and on rolling boards. All figures are in millimeters if not otherwise stated.

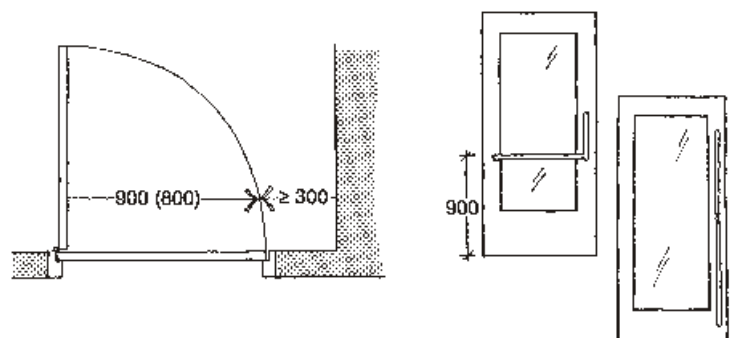

Fig. 4 Door clearance and pull handle design.

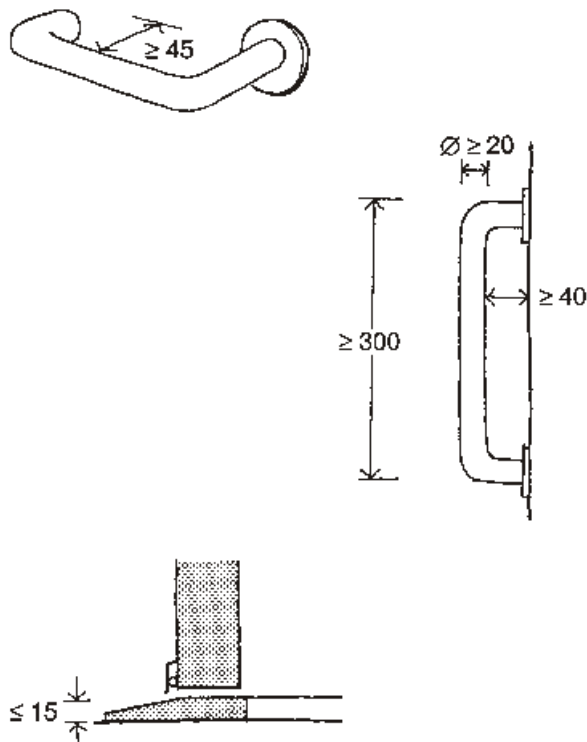

Fig. 5 Door handle and threshold design.

**Thresholds** should be avoided. If they are needed, they should be well designed not to form barriers to the disabled. The height of thresholds should not exceed 15 mm. They must be clearly defined, for example by contrasting colour, to the adjacent floor surface.

**Verandas and Corridors**

Verandas, corridors and other passageways should ideally allow for two wheelchairs to meet. This means that

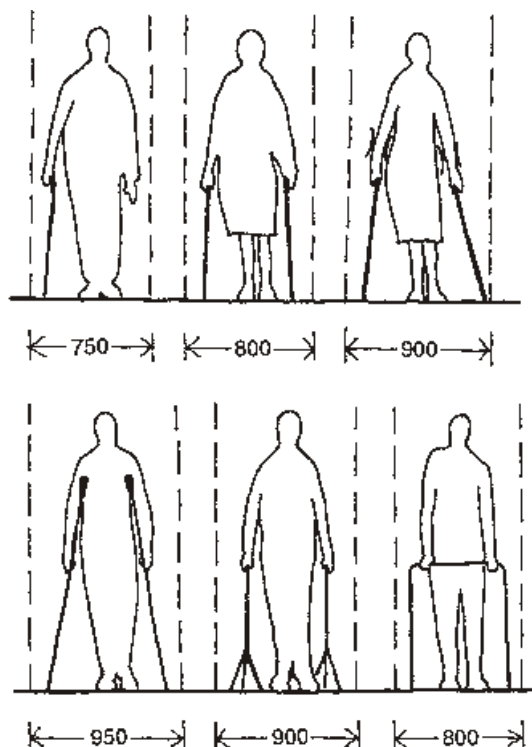

Fig. 6 Typical widths for ambulant people.

the width should be 1800 mm. However, this standard might prove quite costly to meet. To be able to move furniture, stretchers and other cumbersome items, 1500 mm is usually adequate.

A minimum width for passageways is considered to be 1100 mm. Occasional columns etc. may restrict the width down to the absolute minimum of 800 mm.

Long and narrow passageways can be compensated for by occasional, wider passing places. These can also be used for resting.

**Kerbs**

Small differences in height should be avoided. If this is impossible a graded ramp is a good alternative. Low kerbs (< 30 mm) can easily be made more manageable if they are sloped. For wheelchair users a pair of steps is more handicapping than a single step. One high single step is preferred to two low steps.

**Ramps**

A ramp is a simple mean of linking two levels. It is of great use for access by wheelchair, but cannot replace stairs. Many ambulant persons prefer stairs.

A ramp needs additional space that has to be planned for, even when there are not enough resources to build the ramp initially. A ramp with a gradient of 1:20 functions well. A ramp should not be steeper than 1:12. If steeper, the chair might either run away or tip over when descending. However, if practical constraints make it impossible to design a ramp with a flat gradient, even a steep one of 1:8 or 1:6 is better than no ramp at all, provided that steps are also available.

Ramps are good for wheelchairs but often represent a problem for ambulant persons that might have problems descending them. Therefore a ramp with a gradient of more than 1:12 must have an alternative, stepped approach.

One single ramp should not take up a vertical rise of more than 500 mm. Therefore a gradient of 1:12 gives a maximum length of 6 m and a gradient of 1:20, maximum 10 m of length. Between successive ramps there should be a **landing** of not less than 1.8 m (1.3 m is an absolute minimum) with an inclination of maximum 1:50.

A ramp that is 1300 mm **wide** functions well. For two wheel chairs to meet, the ramp should be 1500 mm wide. For short ramps, where there are also steps, the width can be 1000 mm. A width of 900 mm is an absolute minimum. A ramp should be provided with **kerbs** at the edges to hinder wheelchairs from rolling off. Kerbs should not be less than 75 mm high, or 50 mm if there are handrails.

**Handrails** should be on each side of any steep ramp. They should be continuous also at landings. They should continue 300 mm beyond the beginning and end of ramp. The handrails should have a diameter of 30–50 mm and should be placed at a height of 900 mm. Another one should be at 700–750 mm for people confined to conventional wheelchairs. The colour of the handrail should contrast with the colour of the wall. Circular cross-sections are easy to grip.

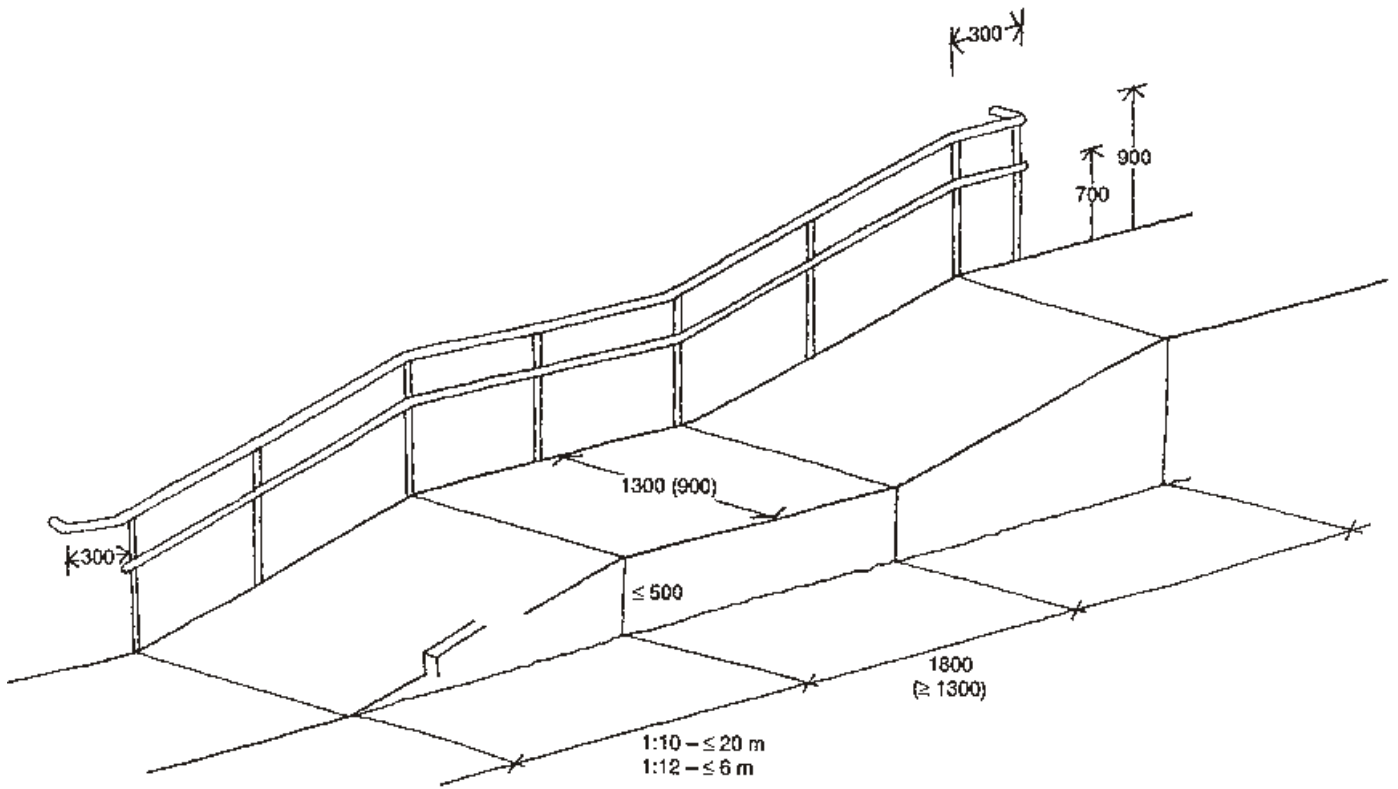

Fig. 7 Design of ramp.

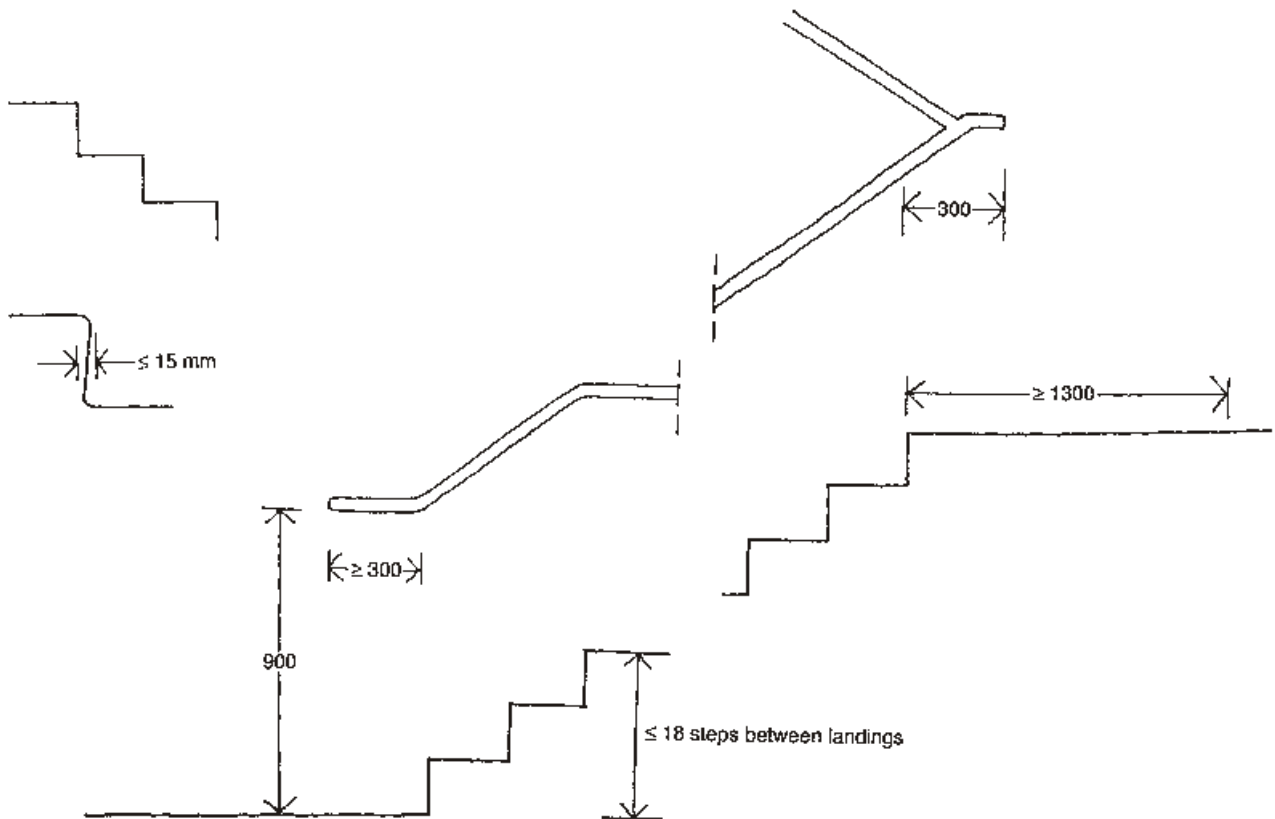

Fig. 8 Design of stairs.

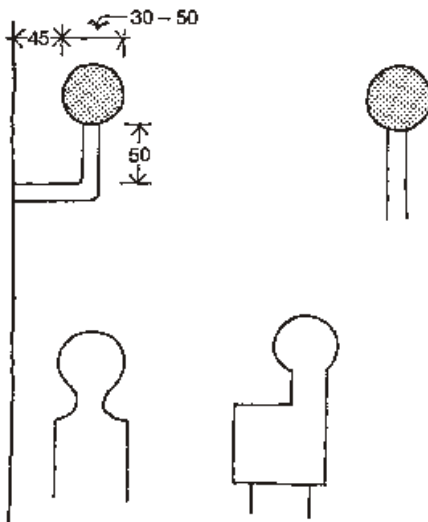

Fig. 9 Design of handrails.

Ramps must have a non-slip surface. Disabled, but ambulant persons easily slip on ramps. Concrete screed finish is dangerous. A textured finish is recommended.

**Stairs**

The design of stairs is crucial for the use by an ambulant person. Perhaps the most important features are that the stair has adequately designed steps and well-proportioned treads and risers. The steps should all have the same tread and the same rise.

It is also crucial that treads are neither sloping nor slippery. Wood treads are safer if they are provided with non slip nosing. Nosing is however hazardous and easy to trip over, if it is badly designed. Protruding nosing should be avoided. However, if this is not possible, it should not project more than 15 mm and be chamfered, not square edged.

The recommended stairway dimensions are (in mm):

Stairway type	stairway width	treads	risers
outdoors	1300	≥ 300	≤ 150
in institutional building	1200	≥ 300	≤ 150
servicing several dwellings	1000	≥ 250	≤ 180
within dwelling	800	≥ 220	≤ 220

Straight stairs are easier to use by disabled than those with other lay-outs. Stairs with more than 18 steps should be divided by landings. It is usually good to have a landing after twelve steps. This landing should be at least 1300 mm long.

Open staircases are hazardous to people who are unsteady. Stairs should have handrails on both sides. The handrails must extend beyond the first and last steps by at least 300 mm. A handrail needs to have a good shape, as for ramps, to grip.

The beginning and end of the stairs shall be well lit and accentuated with colour, different floor treatment, etc. The actual run of steps itself must also be well lit.

**Lifts**

For most people with moving difficulties, a lift is ideal for vertical communication, but the cost for both investment and maintenance is often prohibitive. However, it

does not cost much to **plan for a future lift** by allocating sufficient space.

A conventional lift requires a floor area of about 1700 × 1400 mm. It should be possible to dig 1400 mm under the ground floor level, and provide space for future machinery at the top of the intended shaft.

A hydraulic lift is somewhat less expensive than a conventional lift. The machine room can be located away from the shaft, and the pit depth below the lowest level need not to be greater than 500 mm.

For a short vertical distance, there are several not too costly alternatives. One of these is the stair lift which costs about 1/10 of a conventional lift. Another option is the so called home lift.

Space for a future lift should be located near the main entrance. There should be a clear area in front of the intended lift of at least 1500 × 1500 mm.

**Layout**

To build an (institutional) building of two or more floors without a lift, means to handicap disabled persons, at least to a certain degree. Since institutions need to be accessible to all, it is important that such a building has a well conceived and flexible design. An auditorium, for example, should not be reached by a flight of stairs. The distribution of rooms is also a factor in obtaining flexibility. If different rooms, such as meeting rooms, classrooms, toilets, labs, etc. are distributed so that one or a few are also available on the ground floor, teaching or other activities can be rescheduled according to the particular needs of the disabled.

**Lavatories**

Not all lavatories have to meet the space requirements of people using a wheelchair. However, if there is space enough for a person using a wheelchair then there is space enough for ambulant people, using crutches or other technical aids.

In a lavatory adapted to the disabled it is essential to plan extra space for a helper, since some disabled can not use lavatories by themselves. Room for lifting or moving the disabled should therefore be provided for, and it is important to have a clear space in front of the door.

The minimum space for disabled with conventional wheelchair is 1700 × 1700 mm, or 2000 × 1500 mm. This space can be somewhat reduced if the washing facilities are placed outside the lavatory.

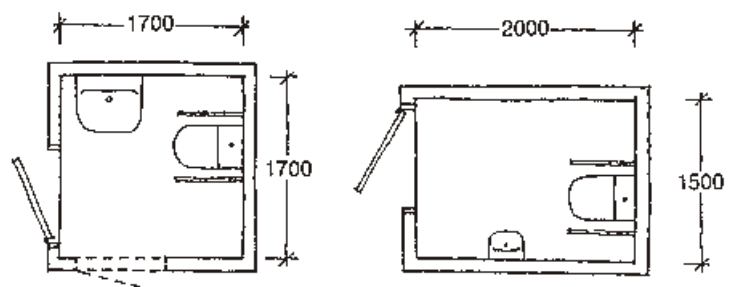

Fig. 10 Minimum dimensions for lavatories.

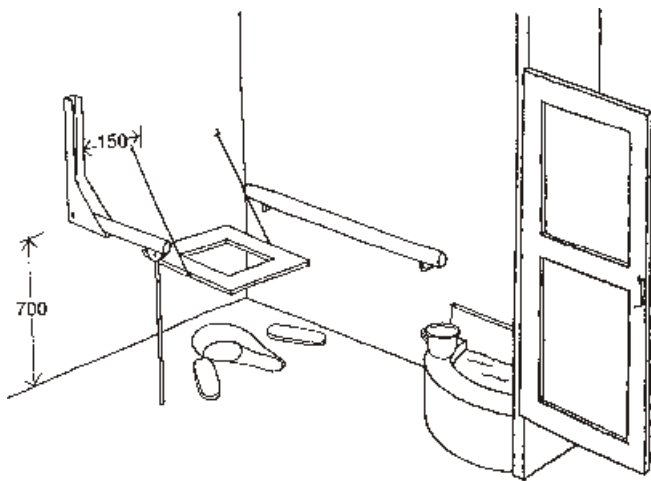

Fig. 11 A fold-down seat over a pit latrine.

A lavatory should be provided with appropriate hand-rails. The floor should be non-slippery and there should be no obstacles to prevent turning, or access to the seat. Lavatory fittings must be firmly fixed and if possible reached from a sitting position.

It should be mentioned that being able to sit is important for any disabled person. Physically disabled persons can sometimes not squat. If the lavatory is a pit latrine, arrangements can be made so that it may be used more easily by disabled. A seat construction fastened to the wall, which can be tipped down from the wall when needed, will allow the person to sit comfortably.

Further, firmly fixed grab rails, about 35 mm in diameter and placed 700 mm above floor level, at both or at least at one side of the seat or pit (150 mm from the side of the seat) will help the individual to hold herself steady and to move from seat to wheelchair or simply to get up on her feet again. The door should open outwards.

### Designing for People with Difficulties in Seeing

People with seeing difficulties are helped by an environment where it is easy to orient oneself and to move. The aim is therefore to try to create an overall logical environment with many clues or "landmarks." This is to provide information about the surroundings, and to make the environment more "readable" by accentuating different building parts. This can be achieved both at a large scale by means of good general lighting, a contrasting floor, etc. and at a small scale, by, for example, accentuating a door by contrasting colour or using a clear logotype in an adequate size at the right height on a sign.

#### Glare

Glare is a problem for people with impaired vision. To reduce glare, try to avoid glossy objects, and high contrast in lighting. The difference in light from one place to another should not differ by more than 2/3. Windows might increase glare if not properly located or shaded. Windows at the end of corridors should be avoided, unless carefully designed.

#### Use of Colour

To make things more clear, contrasting colours can be used. However, differences in lightness (dark blue versus light blue) are more effective than differences in colour (red and blue of the same lightness). Examples of colour combinations with high contrast are yellow/black and white/black. Visually strong colours are: orange, yellow, and yellowish green. The combination yellow/black is often used to warn of danger. Avoid large dark areas.

It is also important to create a **safe environment**, avoiding obstacles where people with weak sight might get hurt. Protruding signs or other objects should have minimum clearance of 2100 mm. Stairs or columns,

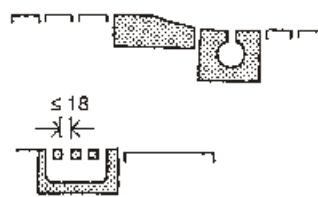
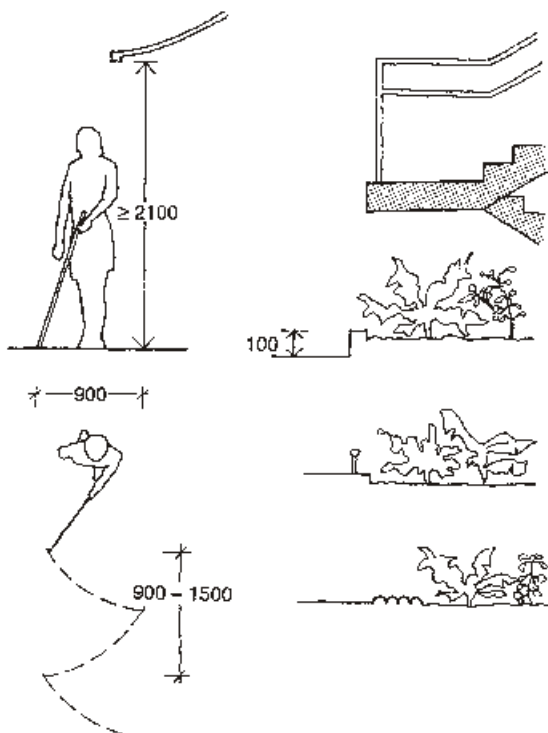
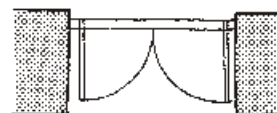
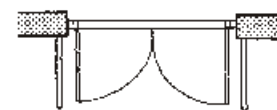

Fig. 12 Some design aspects for people with seeing difficulties.



Recess doorways to avoid opening into pathways



Or... build suitable protective screens

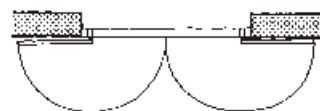

If there is no space, be sure the door opens 180° to lie flat against the wall.



which can cause accidents, should be accentuated by strong colours. Large glass areas should be marked with a line or another sign in a strong colour, 1400–1600 mm above floor level.

The texts on signboards should be dimensioned so that people with weak sight also can see them at the intended distance. Letters should be at least 15 mm high and with a thickness 1/5 the height of the letter. Braille text, meant to be read with the fingertips, should be raised at least 1 mm from the background.

**To Feel One’s Way**

Visually weak people often feel their way, with their fingertips, a stick or by other means. Providing information by different textures, studs or other cues on the underside of handrails, orientation of stones on the floor, etc. can be very useful.

Acoustic differences can also be used, indicating spatial characters. A change of the ceiling, for example, can be read as an important landmark by the blind.

**Designing for People with Difficulties in Hearing**

People with hearing problems have difficulties in understanding sounds in a noisy environment. Therefore, they need spaces that are acoustically well designed and insulated.

**Acoustics**

What is an acoustically well designed room? Hard surfaces reflect the sound, giving more reverberation, while soft surfaces absorb the sound and give less reverberation. A room can be provided with absorbents such as textiles or acoustic boards to diminish the resonance.

For good acoustics, i.e. in a classroom or meeting hall, the wall nearest the speaker should be hard, and the opposite wall soft and sound absorbing. The ceiling directly above the speaker or teacher should be of a hard, sound reflecting material. If the ceiling is covered with absorbents, a great deal of the speaker’s voice might not reach the end rows of the room. Absorbents are ideally placed in the corners where the ceiling meets the wall, diagonally opposite each other. Thus early sounds are still retained, and the reverberation is diminished. This is highly recommended.

The floor should have a surface that diminishes disturbing sounds, such as footsteps, the pulling of chairs, etc. It is also important that rooms are disturbed as little as possible by external sounds. This can be avoided by:

- Noisy rooms located far away from quieter spaces
- Buffer zones between quiet and noisy rooms
- Partition walls pass the false ceiling to reach the roof, and are made of a heavy material.
- Steel-sheet roofing creates much noise in heavy rain. A ceiling in an insulating material reduces this sound.

To minimize distances, rooms for meetings or teaching should be square or almost square. Rectangular rooms have a longer side that can increase difficulties in seeing and hearing. A useful rule is that the distance between the speaker and the listener should be no more than 7 meters.

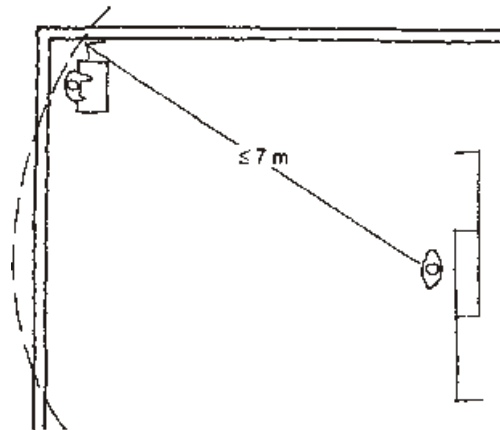

Fig. 14 The distance to the speaker should be less than seven meters for people with hearing difficulties.

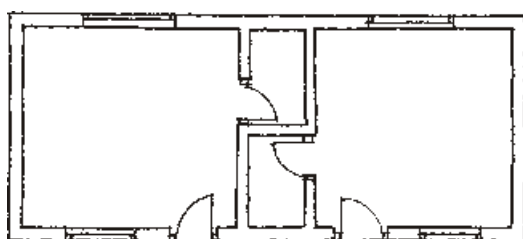

Fig. 13 Buffer zones between noisy rooms is recommended.

## 4 Check List for Barrier-Free Design

Location	Item	Basic Design Requirements	OK?	Notes	OK?	
Outdoor	Layout	Is the layout logical? Is it easy to find the entrance?		Important to persons with seeing difficulties		
		Pathways	Even, slip-resistant surface? In contrasting colours/lightness to surrounding surfaces? Can borders be "read" with a stick? 1300 mm or wider? Are kerbs, if any, low (30 mm) and sloped? If stairs, are there also ramps?			
	Stairs	Same tread and rise throughout?				
		Not sloping or slippery and even treads?				
		Nosing not protruding?			If protruding, less than 15 mm and chamfered?	
		Tread of at least 300 mm?				
		Rise 150 mm or less?				
		1300 mm or wider? Straight?			Can be less on private sites	
		If more than 18 steps, is there a landing 1300 mm long or more?				
	Ramps	Handrail(s) provided at a height of 900 mm? Continuing 300 mm at both ends of ramp?			Circular grip, $\varnothing$ 30–50 mm, contrasting colour preferred.	
		1300 mm (1000 if short) or wider?			900 mm absolute minimum	
		Not steeper than 1:12?			1:20 preferred	
		If steeper than 1:12, is there an alternative, stepped approach?			A short, steep ramp (< 1:6) is better than no ramp at all	
		Vertical rise to landing 500 mm or less?				
		Length of landings 1300 mm or more? Not sloping more than 1:50?				
		Kerbs at edges 75 mm or higher?			50 mm sufficient if handrails	
		Double handrail(s) provided at heights of 700 and 900 mm? Continuing 300 mm at both ends of ramp?			Circular grip, $\varnothing$ 30–50 mm, contrasting colour preferred.	
		Non-slip, coarse surface?				
		Signs	Are letters 30 mm high or more, and bold?			Major signs
	If protruding, clearance at least 2100 mm?				Valid for any object	
	Is Braille text provided (for fingertip reading)?					
	Indoor	Layout	Is the layout logical?		Important to persons with seeing difficulties	
			Is at least one room of each main type located on the ground floor?		Reduces need for ramps in multi-storey buildings	
Are noisy rooms located away from quieter?						
If different floor levels, are there stairs and ramps?						
Stairs		Same tread and rise throughout?				
		Not sloping or slippery, and even treads?				
		Nosing not protruding?			If protruding, less than 15 mm and chamfered?	
		Tread of at least 300 mm in institutional buildings?			250 mm OK for stairways serving several dwellings; 220 mm OK within a dwelling	
		Rise 150 mm or less in institutional buildings?			180 mm OK for stairways serving several dwellings; 220 mm OK within a dwelling	
		1200 mm or wider? Straight?			1000 mm OK for stairways serving several dwellings; 800 mm OK within a dwelling	

Location	Item	Basic Design Requirements	OK?	Notes	OK?	
Indoor		If more than 18 steps, is there a landing 1300 mm long or more?				
		Handrail(s) provided at heights of 900 mm? Continuing 300 mm at both ends of stair?		Circular grip, Ø 30–50 mm, contrasting colour preferred.		
		Well lit and in contrasting colour?				
	Ramps		1300 mm (1000 if short) or wider?		900 mm absolute minimum	
			Not steeper than 1:12?		1:20 preferred	
			If steeper than 1:12, is there an alternative, stepped approach?		A short, steep ramp (1:6) is better than no ramp at all	
			Vertical rise to landing 500 mm or less?			
			Length of landings 1300 mm or more? Not sloping more than 1:50?			
			Double handrail(s) provided at heights of 700 and 900 mm? Continuing 300 mm at both ends of ramp?		Circular grip, Ø 30–50 mm, contrasting colour preferred.	
			Kerbs at edges 75 mm or higher?		50 mm sufficient if handrails	
			Non-slip surface?			
	Verandas and corridors		Width 1800 mm or more?		1100 mm acceptable 800 absolute minimum	
		Space for lift	Floor areas 1400 × 1700 mm or more? Space available in front of future lift door 1500 × 1500 mm or more			
	Rooms		Has the acoustic environment been considered?			
			Is adequate lightning provided?			
			Are rooms for e.g. teaching more or less square?		Max. lip reading distance about 7 m	
	Lavatory (showers)		Floor area 1700 × 1700 mm, or 2000 × 1500 mm (less if washing facilities outside)?		Allows for wheelchair users. Does not apply to all lavatories	
			Located on ground floor		Does not apply to all lavatories	
			Seat available for those who cannot squat?		Does not apply to all lavatories	
			Grab rail(s) at a height of about 700 mm?		Does not apply to all lavatories	
		Door opens outwards?				
Doors (and openings)		800 mm or wider?		900 mm preferred		
		Space of at least 300 mm next to doors?				
		Does not obstruct passage in corridors when open?				
		Space to manoeuvre wheelchair while opening?				
		Doors to toilets or other small spaces open outwards?				
		Lever handles, or vertical pull handles?				
		Height of thresholds 15 mm or less?		Contrasting colour preferred		
	Windows		Not at end of corridors?			
		Properly shaded?				
Implements		Placed at a height of about 900 mm and at least 400 mm from corners?				
Signs		Are letters 15 mm high or more, and bold?				
		If protruding, clearance at least 2100 mm?		Valid for any object		
		Is Braille text provided (for fingertip reading)?				
Technical design		Do partition walls pass a false ceiling to reach the roof?				
		Are walls made of sound insulating materials?				

Note: These minimum requirements are amalgamated from codes in several countries. Measures are approximate. Please consult your country's building code, and follow that whenever it exceeds requirements in this Summary Check List for Barrier-Free Design.

## Bibliography

- 1981 *Adaption of Buildings and Human Settlements for the Disabled People in Developing Areas. Preparatory report – Inventory of relevant on-going activities.* Stockholm: White & Partners AB, Sweden.
- Altunel, Arzu  
1993 *Designing of the Built Environment for the Disabled.* Lund: Department of Town Planning, Lund University, Sweden.
- 1974 “Barrier-free Design”. *Human Settlements IV 3.* United Nations.
- 1969 *Basics of Housing Management.* New York: Department of Economic and Social Affairs, United Nations.
- Beckman, Mats  
1976 *Building for Everyone. The Disabled and the Built Environment in Sweden.* Stockholm: Ministry of Housing and Physical Planning, Sweden.
- 1983 *Designing with Care a Guide to Adaption of the Built Environment for Disabled Persons.* International Year for Disabled Persons 1982 (IYDP). New York, United Nations.
- Goldschmith, Selwyn  
1989 *Facilities for the Disabled. A PSA building design guide.* Property Service Agency. Garston: Building Research Establishment (BRE), UK.
- 1981 *Handicap Adaption of Buildings.* National Board of Housing and Planning (Boverket). Stockholm: Allmänna Förlaget, Sweden.
- Hansson, Lisa and Olle Vävare  
1982 *School for Deaf in Machkos, Kenya. Pre study and Architects Brief.* White & Partners AB. Stockholm: Kenya-Sweden Friendship Association, Sweden.
- 1983 *Pour une architecture attentive. Guide de l’adaption d’environnement construit aux besoins des personnes handicapées.* Année internationale des personnes handicapées 1981. New York, United Nations.
- Pratt, Brian and Jo Boyden  
1985 *The Field Director’s Handbook. An Oxfam manual for development workers.* Oxford: Oxfam. UK.
- Ratzka, Adolf D  
1988 *Report of the Third International Expert Seminar on Building Non-Handicapping Environments: Accessibility Issues in Developing Countries.* Tokyo, Sept 10, 1988. Stockholm: Royal Institute of Technology, Sweden.
- 1987 *Report of the International Expert Seminar Building Concept for the Handicapped.* Stockholm, April 10–12, 1984. Stockholm: Royal Institute of Technology, Sweden.
- 1994 *Report of the Fourth International Expert Seminar on Building Non-Handicapping Environments: Access Legislation and Design Solutions.* Budapest, Sept 2–4, 1991. Stockholm: Royal Institute of Technology, Sweden.
- 1992 *Report of the Fifth International Expert Seminar on Building Non-Handicapping Environments: Access Legislation and Design Solutions.* Harare, Jan 16–18, 1992. Stockholm: Royal Institute of Technology, Sweden.
- Reuterswärd, Lars  
1990 *Handbook on Design Guidelines for Easy Access to Educational Buildings by Physically Handicapped persons.* United Nations Educational, Scientific and Cultural Organization UNESCO. Reprint 1992 by UNESCO. Lund: Sweden Habitat AB, Sweden.
- Shalinsky, William  
1983 *The Physical and Psycho-social Environments of Disabled Persons.* University of Waterloo, Canada.
- Svensson, Elisabet  
1991 *Bygg ikapp handikapp.* Solna: Svensk Byggtjänst och Handikappinstitutet, Sweden.
- Thiberg, Sven  
1987 *Report of the Second International Expert Seminar on Building Non-Handicapping Environments: Renewal of Inner Cities.* Prague, Oct 15–17, 1987. Stockholm: Royal Institute of Technology, Sweden.