

Installation
Operation
and
Maintenance
Instructions

Ice Machines

15iM
25iM

GOEDERERS
Trusted since 1951



TABLE OF CONTENTS

| | |
|---|----|
| Unpacking your ice machine..... | 2 |
| Removing the packaging..... | 2 |
| Warranty Registration..... | 2 |
| Installing your ice machine..... | 3 |
| Selecting the location..... | 3 |
| Cabinet Clearances..... | 3 |
| Leveling legs..... | 3 |
| Grounding method..... | 3 |
| Electrical Requirements..... | 3 |
| Connecting the water supply..... | 4 |
| Using your ice machine..... | 5 |
| Turning on your ice machine..... | 5 |
| Ice machine operation..... | 5 |
| Dimensions For 15iM Solid Door..... | 6 |
| Recommended Rough in Opening Dimensions | |
| For 15iM Solid Door..... | 6 |
| Dimensions For 25iM Solid Door..... | 7 |
| Recommended Rough in Opening Dimensions | |
| For 25iM Solid Door..... | 7 |
| Dimensions For 25iM Solid Overlay Door..... | 8 |
| Recommended Rough in Opening Dimensions | |
| For 25iM Solid Overlay Door..... | 8 |
| Full Overlay Panel Installation Instructions..... | 9 |
| Care and Cleaning..... | 12 |
| Condenser air flow..... | 12 |
| Cabinet..... | 12 |
| Interior..... | 12 |
| Defrosting instructions..... | 12 |
| Troubleshooting Guide..... | 13 |
| Obtaining Service..... | 15 |
| Household Product Warranty..... | 16 |

Important Safety Instructions

Warnings and safety instructions appearing in this guide are not meant to cover all possible conditions and situations that may occur. Common sense, caution, and care must be exercised when installing, maintaining, or operating this appliance.

Recognize Safety Symbols, Words, and Labels.

CAUTION

CAUTION-Hazards or unsafe practices which could result in personal injury or property or product damage.

WARNING

WARNING-Hazards or unsafe practices which could result in personal injury.

NOTE

NOTE-Important information to make a problem free installation.

UNPACKING YOUR ICE MACHINE

Remove Packaging

Your ice machine has been packed for shipment with all parts that could be damaged by movement securely fastened. Cut the banding material at the bottom of the carton, unfold the carton at the bottom and remove the carton from the appliance. Remove the plastic bag, styro-foam corner posts and any tape holding the door closed and internal components in place. The owners manual is shipped inside the ice machine in a plastic bag along with the warranty registration card.

Important

Keep your carton packaging until your ice machine has been thoroughly inspected and found to be in good condition. If there is damage, the packaging will be needed as proof of damage in transit. Afterwards please dispose of all items responsibly in particular the plastic bags which can be a suffocation hazard.

Note to Customer

This merchandise was carefully packed and thoroughly inspected before leaving our plant. Responsibility for its safe delivery was assumed by the retailer upon acceptance of the shipment. Claims for loss or damage sustained in transit must be made to the retailer.

DO NOT RETURN DAMAGED MERCHANDISE TO THE MANUFACTURER - FILE THE CLAIM WITH THE RETAILER.

NOTE

If the unit was shipped or has been laying on its back for any period of time allow the ice machine to sit upright for a period of at least 24 hours before plugging in. This will assure oil returns to the compressor. Plugging the ice machine in immediately may cause damage to internal parts.

Warranty Registration

It is important you send in your warranty registration card immediately after taking delivery of your ice machine or you can register online at www.marvelrefrigeration.com.

The following information will be required when registering your unit.

Model Number

Serial Number

Date of Purchase

Dealers name and address

The model number and serial number can be found on the serial plate which is located on the bottom face inside the cabinet.

⚠ CAUTION

Help Prevent Tragedies

Child entrapment and suffocation are not problems of the past. Junked or abandoned refrigerators are still dangerous - even if they sit out for "just a few days".

If you are getting rid of your old refrigerator, please follow the instructions below to help prevent accidents.

Before you throw away your old refrigerator or freezer:

- Take off the doors or remove the drawers.
- Leave the shelves in place so children may not easily climb inside.

INSTALLING YOUR ICE MACHINE

Select Location

The proper location will ensure peak performance of your appliance. We recommend a location where the unit will be out of direct sunlight and away from heat sources. To assure your product performs to specifications the recommended installation location temperature range is from 65 to 90°F (18 to 32°C).

Cabinet Clearance

Ventilation is required from the bottom front section of the unit. Keep this area open and clear of any obstructions. Adjacent cabinets and counter top can be installed around the unit as long as the grille and door access remain unobstructed.

⚠ CAUTION

Front Grille

Do not obstruct the front grille. The openings within the front grille provides air to flow into and exit from the ice machine condenser. For this reason it is important this area to not be obstructed and be kept clean. Marvel does not recommend the use of custom made grilles as air flow may be restricted because of inadequate openings. (See Figure 1).

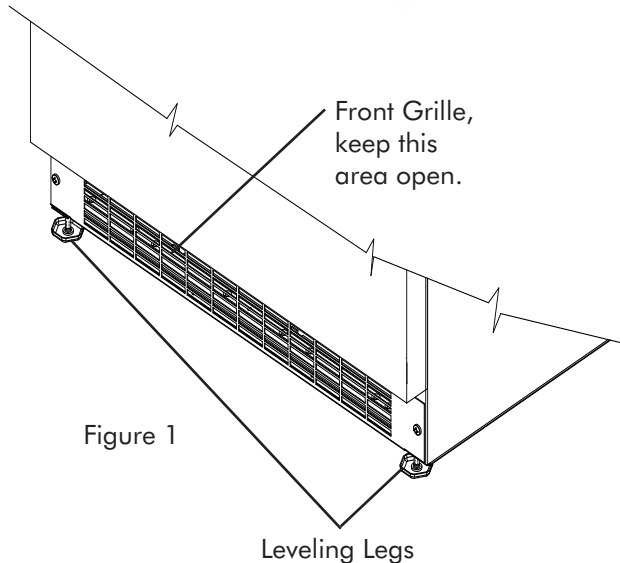

Leveling Legs

Adjustable legs at the front and rear corners of the unit should be set so the unit is firmly positioned on the floor and level from side to side and front to back. Turn leveling legs clockwise to raise unit, counterclockwise to lower it. (See Figure 1).

⚠ CAUTION

- Do not splash or spray water from a hose on the ice machine! Doing so may cause an electrical shock, which may result in severe injury or death.
- This unit should not, under any circumstances, be ungrounded.

Grounding Method

This product is factory equipped with a power supply cord that has a three-pronged, grounded plug. It must be plugged into a mating grounding type receptacle in accordance with the National Electrical Code and applicable local codes and ordinances (see Figure 2). If the circuit does not have a grounding type receptacle, it is the responsibility and obligation of the customer to exchange the existing receptacle in accordance with the National Electrical Code and applicable local codes and ordinances. The third ground prong should not, under any circumstances, be cut or removed.

Electrical Connection

115 volts, 3.3 amps running max. 15 amp dedicated circuit required. 3 prong grounded receptacle required.

⚠ CAUTION

Do not use an extension cord with this appliance.

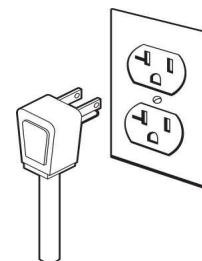

Water Supply

NOTE

Observe and follow all local building codes when installing this appliance.

Attach the supplied water line adapter (Figure 4) to the water valve inlet on the back of the ice machine (See Figure 3). Be sure the rubber washer is in place in the inlet valve nut. Bend the 1/4" copper tubing to suit your installation being sure not to kink the tubing. Use 1/4" copper tubing for your water supply which is available at any local hardware or plumbing supply store. Connect the copper tubing water supply to the copper tubing from the adapter assembly with the provided brass union.

Water pressure must be at a minimum of 20 psi for proper operation.

Make certain all water connections are watertight after installation. Form the tubing so that it will not vibrate against the cabinet body or kink when your ice machine is set in position.

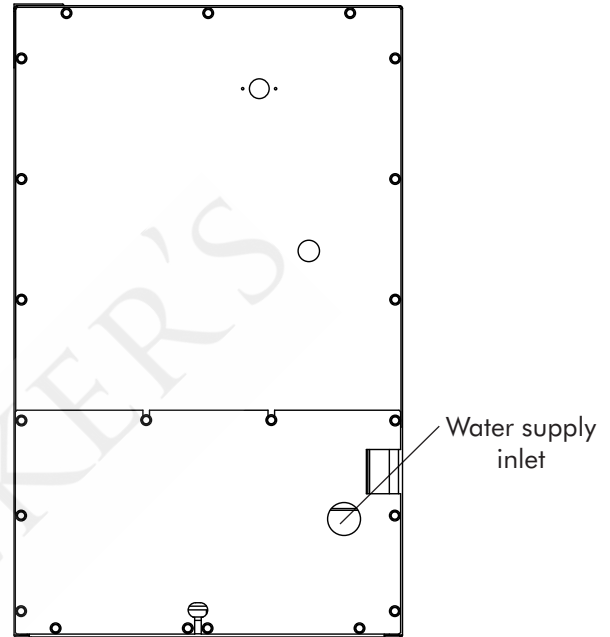

Figure 3
Back view of
ice machine

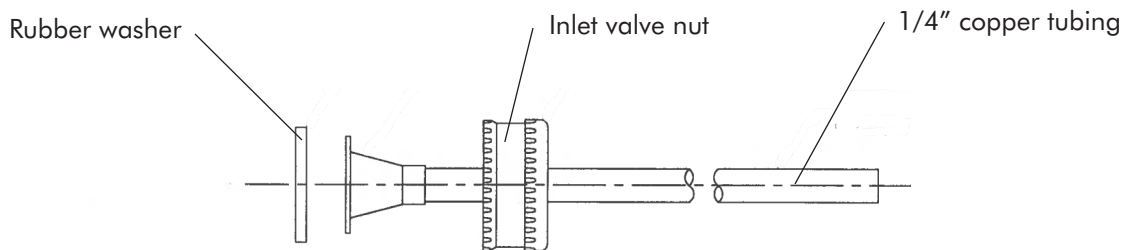

Figure 4

USING YOUR ICE MACHINE

Turning on the ice machine

After connecting the water supply, and setting your ice machine in place plug the power cord into the wall receptacle. Then place the switch located in the grille (see Figure 5) to the "ON" position. The temperature control is factory preset, allow the ice maker to run for 24 hours so the interior temperature will stabilize. If you wish to adjust the interior temperature use a small bladed screwdriver pushed through the right hand side of the grille to turn the temperature control shaft. Turning it clockwise will make the unit colder. Turning it counterclockwise will make it warmer. Turning it counterclockwise until it stops will shut off the compressor and fan motor.

CAUTION

Should you turn off your control, allow at least five (5) minutes before restarting in order to give the motor control time to automatically reset so that it can restart the motor. Electrical power to your unit is controlled by the "ON/OFF" rocker switch located in the front grille. (See Figure 5).

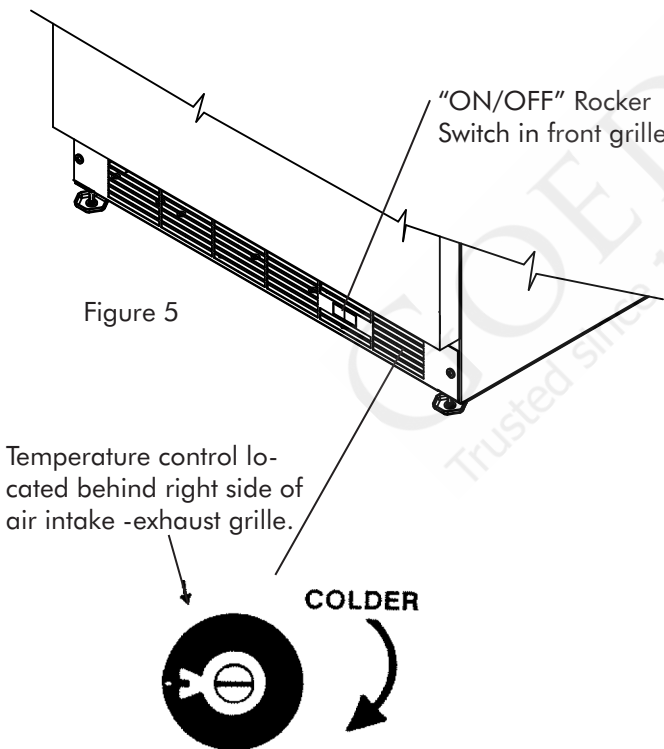

Icemaker operation

- Make certain water pressure is at least 20 psi and no more than 120 psi and the water is turned on.
- The unit must be installed level for proper ice maker operation.
- The shutoff arm wire must be down in its lowest position for the ice maker to operate.
- When the freezer section and ice maker unit has sufficiently cooled, the ice maker will harvest ice cubes automatically.
- When the ice bucket is full, the ice maker will automatically shut off.
- You may manually stop the ice maker by raising the shut off arm to the locking position at the up most position.

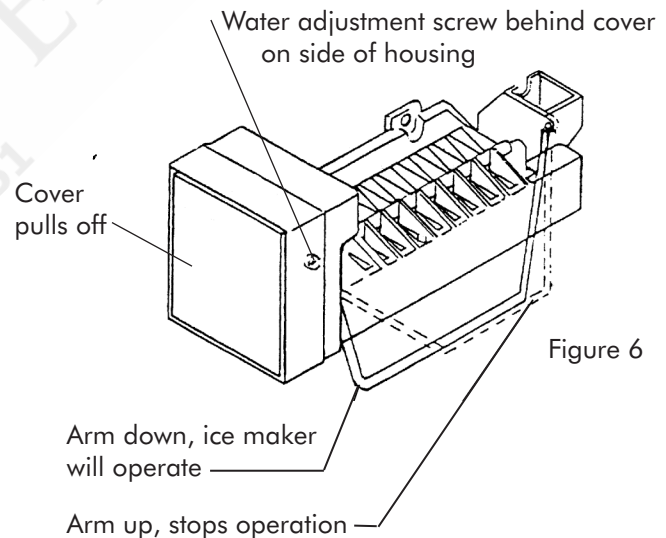

When operation of the appliance is to be discontinued for any length of time, the ice cube cavity in the ice maker should be emptied and dried. The water supply and power supply should also be shut off and the ice bucket should be emptied and cleaned.

If the ice is not used regularly, it will clump together with time. For best ice results, discard ice in the bin as required and allow the ice maker to make a new fresh batch of ice.

DIMENSIONS FOR MODEL 15iM SOLID DOOR

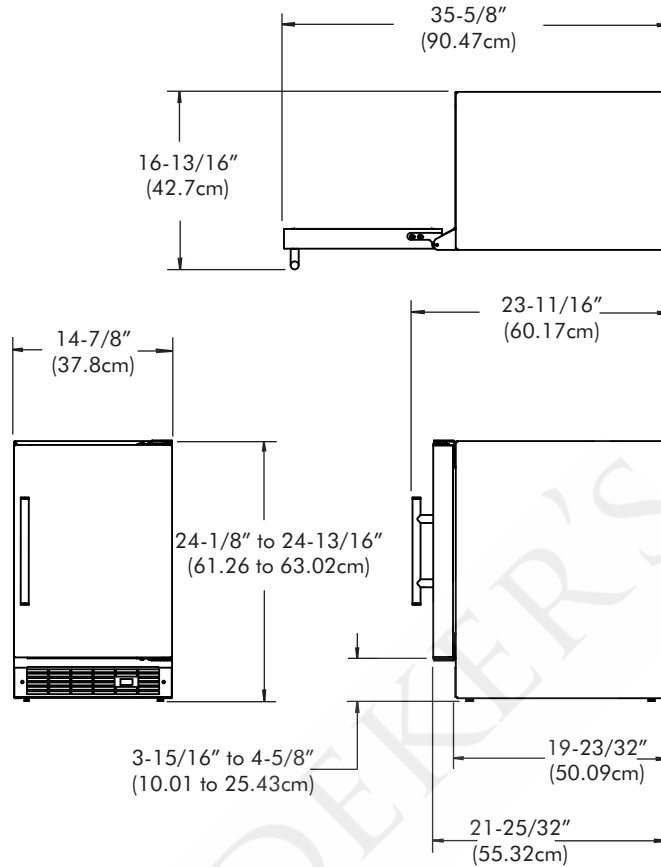

Recommended Rough in Opening Dimensions, 15iM Solid Door

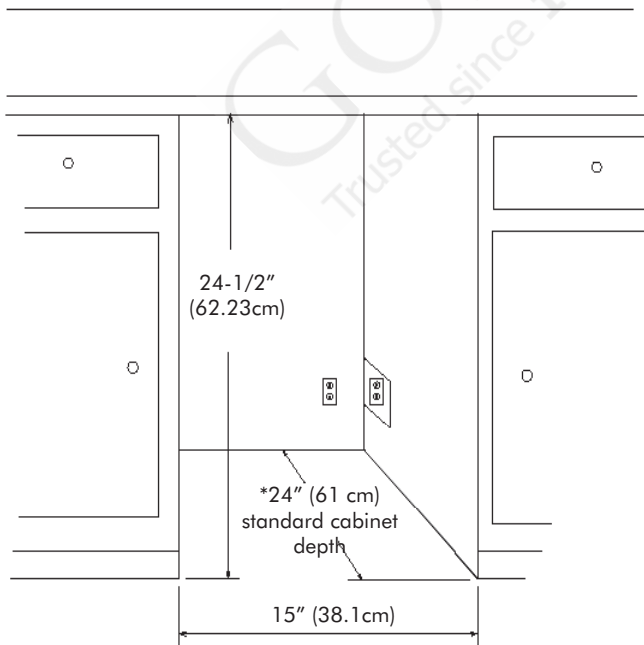

⚠ CAUTION

Electrical Requirements: 115 volts, 3.3 amps running max. 15 amp dedicated circuit required. 3 prong grounded receptacle required.

Power outlet can be located in the back wall behind unit. Add 1" to depth for thickness of plug, or recess outlet 1" into the wall. Power outlet can also be installed in adjacent cabinetry with a cutout for routing of power cord. Follow all local building codes when installing electrical and unit.

Product weight = 72 lbs. (32.7kg.)

* Depth dimension may vary depending on each individual installation.

DIMENSIONS FOR MODEL 25iM SOLID DOOR

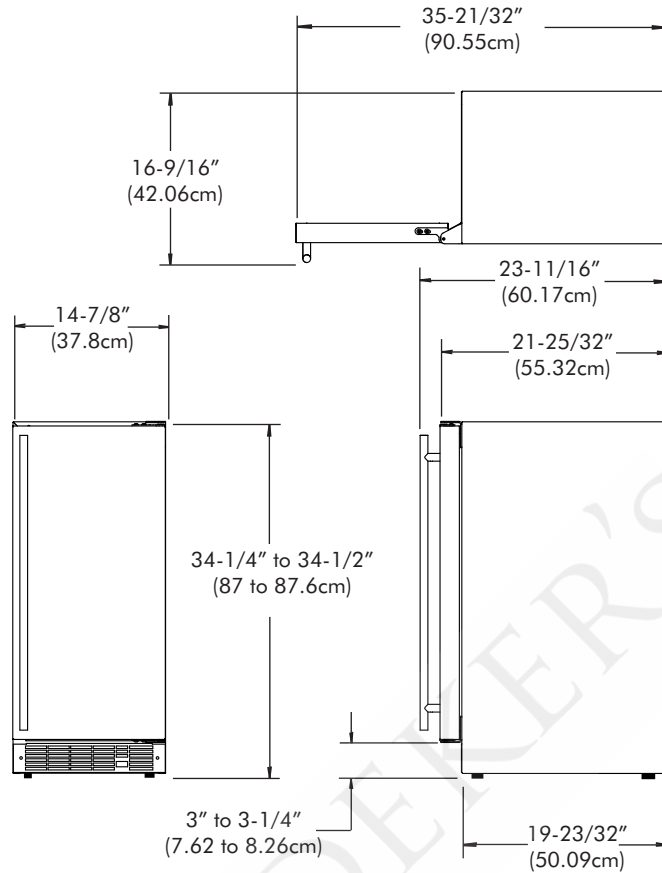

Recommended Rough in Opening Dimensions, 25iM Solid Door

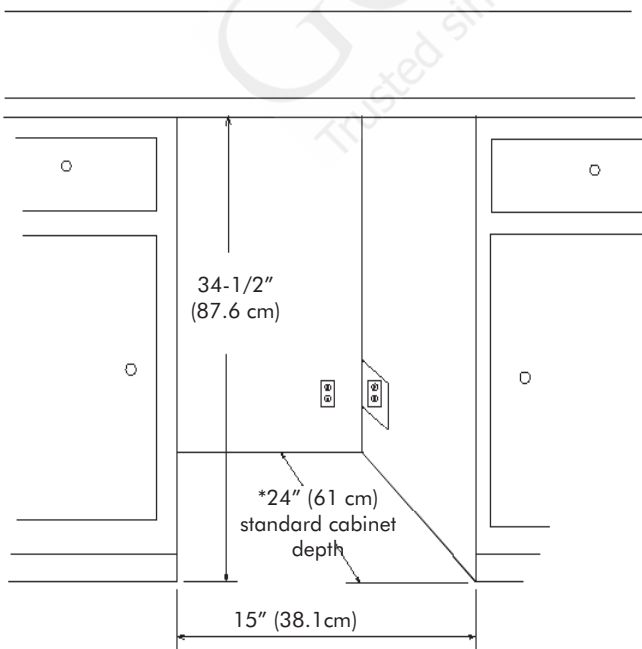

⚠ CAUTION

Electrical Requirements: 115 volts, 3.3 amps running max. 15 amp dedicated circuit required. 3 prong grounded receptacle required.

Power outlet can be located in the back wall behind unit. Add 1" to depth for thickness of plug, or recess outlet 1" into the wall. Power outlet can also be installed in adjacent cabinetry with a cutout for routing of power cord. Follow all local building codes when installing electrical and unit.

Product weight = 86 lbs. (39.1 kg.)

* Depth dimension may vary depending on each individual installation.

DIMENSIONS FOR MODEL 25iM SOLID OVERLAY DOOR

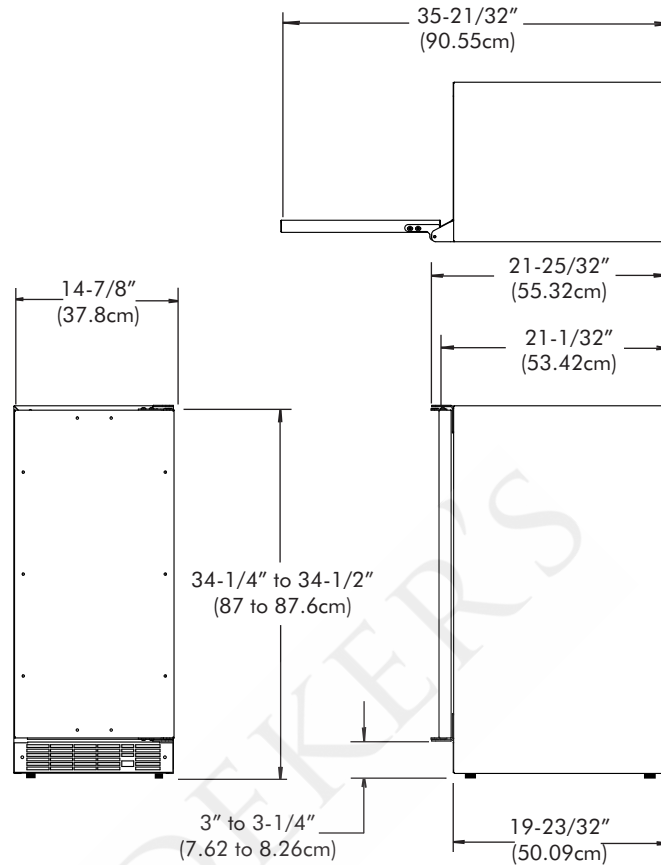

Recommended Rough in Opening Dimensions, 25iM Solid Overlay Door

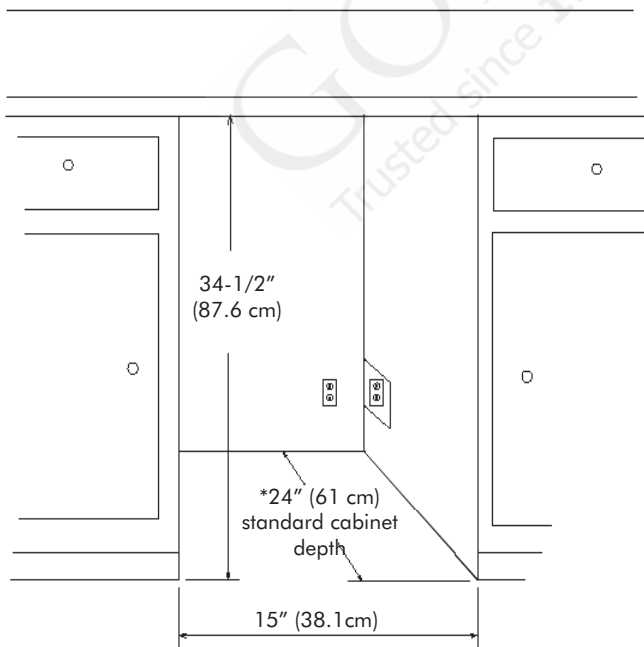

⚠ CAUTION

Electrical Requirements: 115 volts, 3.3 amps running max. 15 amp dedicated circuit required. 3 prong grounded receptacle required.

Power outlet can be located in the back wall behind unit. Add 1" to depth for thickness of plug, or recess outlet 1" into the wall. Power outlet can also be installed in adjacent cabinetry with a cutout for routing of power cord. Follow all local building codes when installing electrical and unit.

Product weight = 86 lbs. (39.1 kg.)

* Depth dimension may vary depending on each individual installation.

FULL OVERLAY PANEL INSTALLATION INSTRUCTIONS

⚠ CAUTION

Step 1: Verify door alignment

The door should be parallel to the sides and top of the ice machine. If alignment is necessary the door may be adjusted by loosening the 2 screws which secure the hinge adapter brackets to the door and adjusting the door side to side. Use a 5/32" allen wrench for this procedure. (See Figure 7 below).

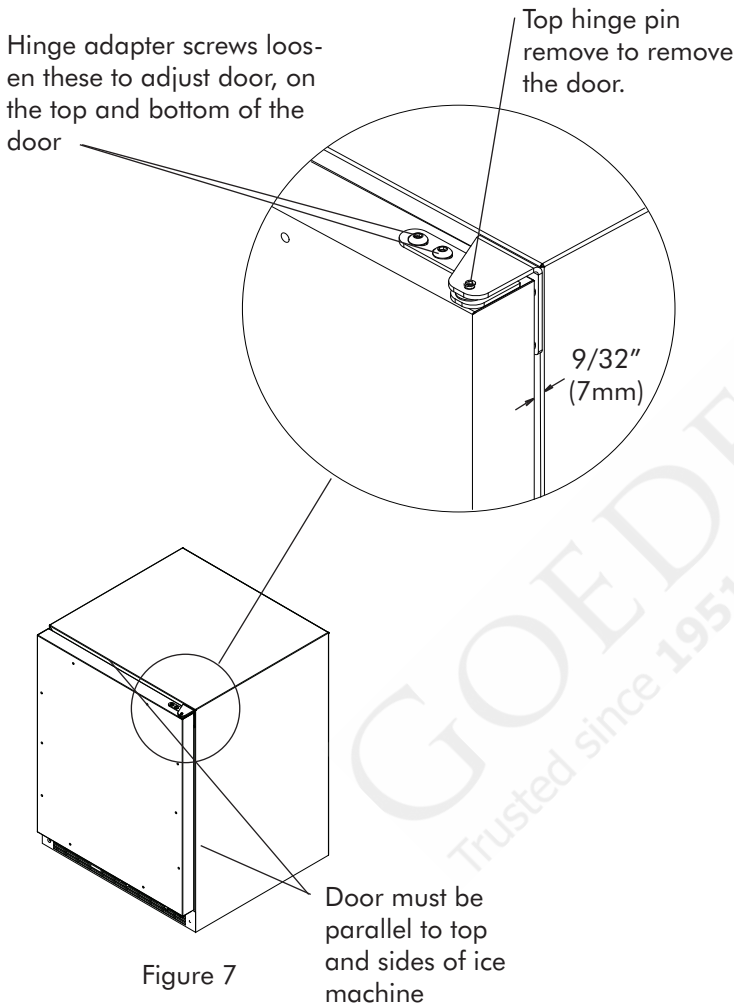

Step 2: Remove door

Remove the top hinge pin from the hinge with an 1/8" allen wrench. Remove the door by angling the top of the door outward and lifting the door off the bottom hinge. (See detail in Figure 7).

Step 3: Remove gasket

Lay the door on its front being careful not to scratch it. Remove the door gasket by peeling up and out of the channel.

Step 4: Cut overlay panel

Depending on the ice machine model cut the overlay panel to the dimensions shown in Figure 8.

NOTE

For overlay with lock option panel thickness to be 3/4" (19mm) maximum to 5/8" (16mm) minimum.

⚠ CAUTION

Weight of the overlay panel should not exceed 20 pounds (9.1 kilograms).

NOTE

For the door closer to work properly it is necessary to maintain a minimum space of 9/32" (7mm) between the door and cabinet flange as shown. This space can be adjusted by adjusting the top and bottom hinge adapters.

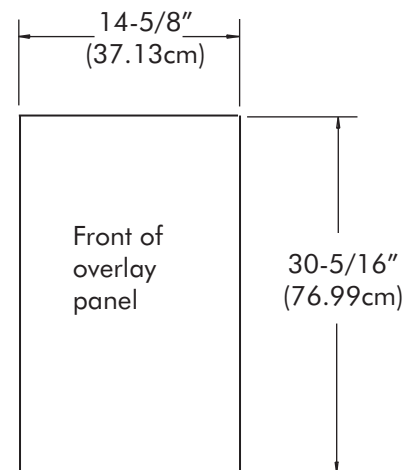

Figure 8
For model 25iM

Step 5: Clamp panel to door

Set the overlay panel on the door front, align the edges, and clamp together. Clamp the panel firmly but be careful not to crush the foam in the door or scratch the door.

FULL OVERLAY PANEL INSTALLATION INSTRUCTIONS

Step 6: Drill holes in overlay panel

Remove the hinge adapter bushings from the top and bottom door hinge adapters. (See Figure 9). Using the holes in the hinge adapters drill 5/16" (8mm) diameter clearance holes into the overlay panels 3/4" (20mm) deep. These will be clearance holes for the top and bottom hinge pins.

Also at this time drill the screw pilot holes (10 required) for attaching the overlay panel to the door. Select the size of the hole from Table A. Be careful not to drill the pilot holes through the overlay panel but only 1/2" (12.7mm) deep.

| Material Type | #8 Wood Screw |
|---------------|------------------------------------|
| Hardwood | 3/32" (2.4mm) Diameter. Pilot Hole |
| Softwood | 5/64 (2.0mm) Diameter. Pilot Hole |

Table A

NOTE

If your ice machine has a door lock proceed to Step 7. If your ice machine does not have a door lock proceed to Step 9.

Step 7: Mark and drill lock hole.

Locate and mark with a pencil the location of the lock hole on the overlay panel, this is the hole in the top corner of the handle side of the door. Remove the clamp and remove the overlay panel from the door. On the backside of the panel where you marked the lock location drill a 13/16" (20.5mm) diameter counterbore 7/16" (11.0mm) deep into the overlay panel. Drill a 15/32" (12.0mm) diameter hole through the overlay panel centered on the counterbore being careful not to splinter the wood on the face side of the panel. (See Figure 9).

Step 8: Assemble the lock parts

Two (2) lock extensions are supplied with the lock. Use the longer extension for a 3/4" thick overlay panel and the shorter one for a 5/8" thick panel. Assemble the lock extension, cam stop washer, spring washer, and set screw to the lock as shown in Figure 9 and 10.

Install this assembly into the overlay panel and secure with the retaining nut using a 15mm socket. Make sure the key slot in the lock is vertical.

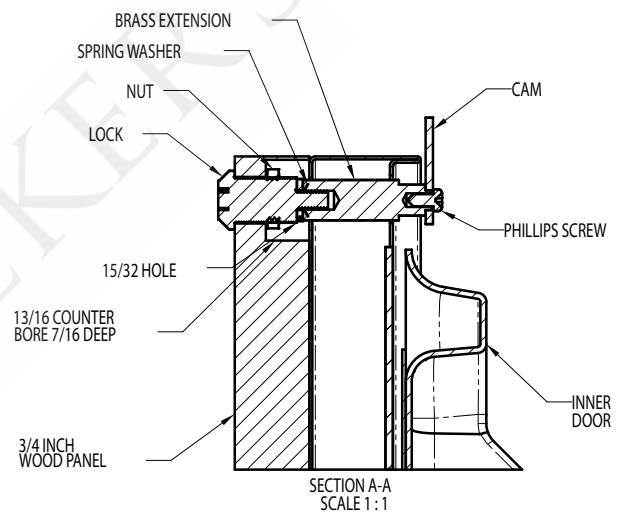

Figure 9

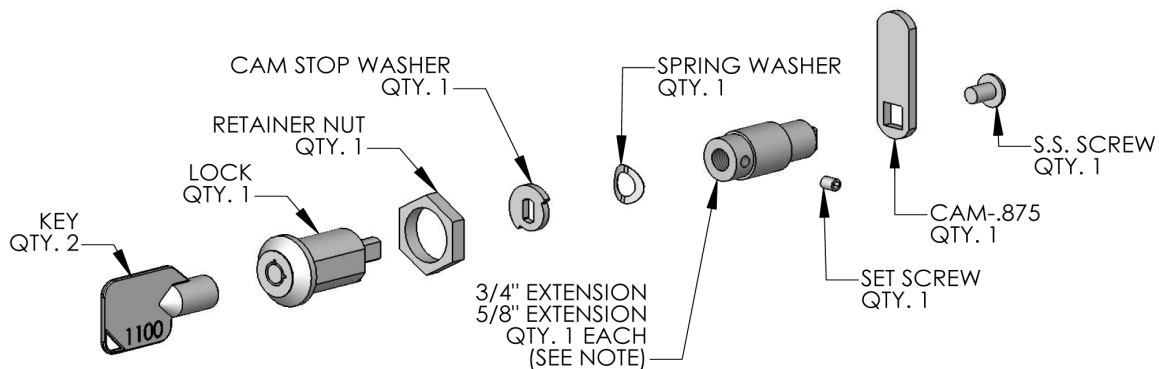

Figure 10

FULL OVERLAY PANEL INSTALLATION INSTRUCTIONS

Step 9: Secure overlay panel to the door.

With the #8 wood screws provided fasten the overlay panel to the door. (See Figure 12).

Step 10: Install lock cam (Models with locks only).

Attach the lock cam to the back of the lock assembly with the phillips head machine screw provided. Orient the lock cam vertically when installing on the lock.

Step 11: Install door gasket

Press the door gasket into the door channel. Make certain the gasket corners are fully inserted. If applicable insert the key into the lock and make certain the lock operates properly.

Step 12: Install the door

Install the top and bottom hinge adapter bushings back into the hinge adapters that were removed in step 6. Install the door by reversing the procedure from step 2. Install the top hinge pin so the screw head is flush with the top surface of the hinge. If applicable insert key into lock and verify the lock cam works properly with the catch bracket on the front of the ice machine cabinet.

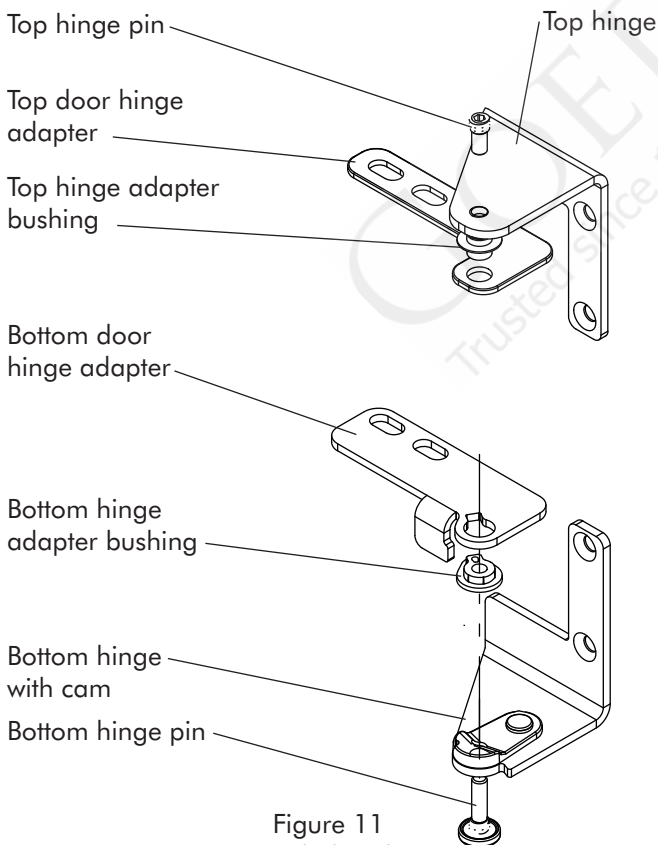

Figure 11
Right hand
hinges shown

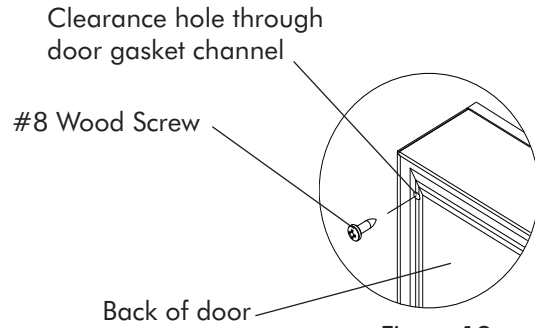

Figure 12

Condenser Air Flow

The machine compartment located beneath the cabinet does not require frequent cleaning; however, satisfactory performance depends on adequate ventilation. Be sure nothing obstructs the required air flow openings in front of the cabinet. At least once or twice a year, brush or vacuum lint and dirt from the front grille openings. See Figure 1 on page 3.

Cabinet

The painted cabinet can be washed with either a mild soap and water and thoroughly rinsed with clear water. NEVER use abrasive scouring cleaners.

Interior

Wash interior compartment with mild soap and water. Do NOT use an abrasive cleaner, solvent, polish cleaner or undiluted detergent.

Care of Unit

1. Avoid leaning on the door, you may bend the door hinges or tip the unit.
2. Exercise caution when sweeping, vacuuming or mopping near the front of the unit. Damage to the grille can occur.
3. Periodically clean the interior of the unit as needed.
4. Periodically check and/or clean the front grille as needed.

Defrosting Instructions

1. Push the rocker switch located in the front grille to the "OFF" position.
2. Remove the ice bucket and place a towel in the lower front area of the ice maker to absorb the defrost water.
3. After defrosting is completed replace the ice bucket and press the rocker switch to the "ON" position.

WARNING

Do not use an ice pick, knife, or any type of sharp object to remove the ice. Doing so may puncture the units refrigerant system and damage it beyond repair. You may speed up defrosting by filling the ice bucket with hot water and placing it back into position.

GOEDEDEKERS
Trusted since 1951

TROUBLESHOOTING YOUR ICE MACHINE

Before You Call for Service

If the unit appears to be malfunctioning, read through this manual first. If the problem persists, check the troubleshooting guide below. Locate the problem in the guide and refer to the cause and its remedy before calling for service. The problem may be something very simple that can be solved without a service call. Some remedies listed in the Troubleshooting Guide are very complex. Consulting or contracting a qualified service technician may be necessary.



Electrocution Hazard - Never attempt to repair or perform maintenance on the unit until the main electrical power has been disconnected.

| Problem | Possible Cause | Remedy |
|--|---|---|
| Unit operates but does not produce any ice | <ul style="list-style-type: none"> • The unit has just been started and it has been less than 24 hours. • Water supply is not turned on. • Inadequate water pressure to unit. • The ice maker shut off arm is in the uppermost position. • Freezer section has not reached temperature. • Thermostat control set too warm. • Condenser fan air flow is restricted. • Room and/or water temperature is too warm. | <ul style="list-style-type: none"> • Typical ice production is 2 pounds per day. Allow for the freezer section to reach temperature and the ice maker to cycle and accumulate ice. • Turn on water supply to the unit. • Water pressure to the unit must be at a minimum of 20 psi. • When the ice maker shut off arm is in the uppermost position, the ice maker is off. Flip the shut off arm down to turn on the ice maker. • Allow the freezer section to reach temperature. • Turn the temperature control to a higher number to allow the unit to run colder. Allow 24 hours before readjusting the temperature control. • Make certain the grille in front of the unit is free and open for air circulation. Clean grille as required. • Move the unit to an area where ambient temperature is below 90°F. The unit should not be placed next to a heat source such as an oven. Check for cold water connection. |
| Small ice cubes | <ul style="list-style-type: none"> • Water input may require adjustment. | <ul style="list-style-type: none"> • Due to differing water pressures, the ice maker water input may require adjustment. See Figure 6 on page 5 for water adjustment screw location. |
| Ice cubes are sticking together. | <ul style="list-style-type: none"> • Ice consumption is low. • Room temperature is too warm. | <ul style="list-style-type: none"> • Use the ice in the bin frequently. Ice will stick together if left in insulated bin over long periods of time. • Move the unit to an area that is below 90°F. |

TROUBLESHOOTING YOUR ICE MACHINE

| Problem | Possible Cause | Remedy |
|--|--|---|
| Unit too warm or too cold inside. | <ul style="list-style-type: none"> • Control set too warm or cold • Airflow to front grille blocked. • Excessive usage or prolonged door openings. • Door gasket not sealing properly. | <ul style="list-style-type: none"> • Adjust temperature colder or warmer as required. Allow 24 hours for temperature to stabilize. • Airflow must not be obstructed to front grille. See “clearances” on page 3. • Allow temperature to stabilize for at least 24 hours. • Adjust or replace door gasket. |
| Noise or Vibration | <ul style="list-style-type: none"> • Unit not level • Water line tubing vibration. | <ul style="list-style-type: none"> • Level unit, see “Leveling Legs” on page 3. • Adjust the tubing as necessary to eliminate unwanted vibrations. |
| Unit will not run. | <ul style="list-style-type: none"> • Unit turned off • Power cord not plugged in. • No power at outlet. | <ul style="list-style-type: none"> • Turn unit on. See “Set the temperature control” on page 4. • Plug in power cord. • Check house circuit. |
| Moisture collects on outside surface of cabinet. | <ul style="list-style-type: none"> • Hot and humid conditions. | <ul style="list-style-type: none"> • Extremely hot and humid conditions can cause condensation on outside of the cabinet. As humidity and/or temperature decreases, the condensation will disappear. |
| Moisture collects on inside of the unit. | <ul style="list-style-type: none"> • To many door openings. • Prolonged door openings. • Hot and humid conditions | <ul style="list-style-type: none"> • Limit the amount of door openings. • Limit the amount of time with the door open. • Extreme hot and humid conditions. Move unit to a controlled environment. |

OBTAINING SERVICE

If Service is Required:

- If the product is within the first year warranty period please call Marvel Customer Service at 800.223.3900 for directions on how to obtain warranty coverage in your area.
- If the product is outside the first year warranty period, Marvel Customer Service can provide recommendations of service centers in your area. A listing of authorized service centers is also available at www.marvelrefrigeration.com under the service and support section.
- In all correspondence regarding service, be sure to give the model number, serial number, and proof of purchase.
- Try to have information or description of nature of the problem, how long the unit has been running, the room temperature, and any additional information that may be helpful in quickly solving the problem.
- Fill in pertinent information below regarding your product for future reference.

| For You Records | |
|---|--|
| Date of Purchase | |
| Dealer's name | |
| Dealer's Address | |
| Dealer's City | |
| Dealer's State | |
| Dealer's Zip Code | |
| Appliance Serial Number | |
| Appliance Model Number | |
| Date Warranty Card Sent (Must be within 10 days of purchase). | |

HOUSEHOLD PRODUCT WARRANTY

Entire Product

Limited One Year Parts and Labor Warranty

Marvel warrants that it will supply all necessary parts and labor to repair or replace in the end user's home or office, any component which proves to be defective in material or workmanship, subject to the condition and exclusions stated below, for a period of one year from the date of purchase by the end user.

Additional Second Through Fifth Year

Limited Parts Only Warranty

During the four years following expiration of the one year limited warranty, Marvel will supply replacement parts for the hermetically sealed refrigeration system which consists of the compressor, condenser, drier, accumulator, bypass valve, connecting tubing and the evaporator that are proven to be defective due to workmanship or materials subject to the conditions and exclusions below.

The above warranties do not cover:

- Shipping costs of replacement parts or returned defective parts.
- Customer education or instructions on how to use the appliance.
- Any content loss due to product failure.
- Removal or installation of product.

Nor do the above warranties cover failure of this product or its components due to:

- Transportation or subsequent damages.
- Commercial use or use other than normal household or small office.
- Improper installation, misuse, abuse, accident or alteration, use of wiring not conforming to electrical codes, low or high voltages, failure to provide necessary maintenance, or other unreasonable use.

Parts or Service

Not Supplied or Designated by Marvel

The above warranties also do not apply if:

- The original bill of sale, deliver date, or serial number cannot be verified.
- Defective parts are not returned for inspection if so requested by Marvel.
- The refrigeration equipment is not in the possession of the original end use purchaser.

The warranties set forth herein are the only warranties extended by Northland-Marvel. Any implied warranties, including the implied warranty of merchantability, are limited to the duration of these express warranties. In no event shall Northland-Marvel be liable for any consequential or incidental damages or expenses resulting from breach of these or any other warranties, whether express or implied.

Some states do not allow the exclusion or limitation of consequential damages or a limitation on how long an implied warranty lasts, so the above exclusion or limitation may not apply to you. This warranty gives you specific legal rights and you may have other rights that may vary from state to state.

No person, firm, or corporation is authorized to make any other warranty or assume any other obligation for Northland-Marvel. These warranties apply only to products used in any of the fifty states of the United States and the District of Columbia.

To obtain performance of this warranty, report any defects to:

Northland-Marvel
P.O. Box 400
1260 E. Van Deinse St.
Greenville MI 48838

Phone: 800.223.3900

GOEDEKER'S
Trusted since 1951

GOEDEKER'S
Trusted since 1951

GOEDEKER'S
Trusted since 1951



PART OF THE AGA RANGEMASTER GROUP

Northland-Marvel
P.O. Box 400
1260 E. Van Deinse St.
Greenville MI 48838

800.223.3900

41011771-EN Rev D
11/10/09

www.marvelrefrigeration.com

All specifications and product designs subject to change without notice. Such revisions do not entitle the buyer to corresponding changes, improvements, additions, replacements or compensation for previously purchased products.