

Unofficial Comment Form

Project 2010-17 Definition of Bulk Electric System Phase 2 | First Draft

Please **DO NOT** use this form for submitting comments. Please use the [electronic form](#) to submit comments on the first draft of the Definition of the Bulk Electric System (Project 2010-17 – Phase 2). The electronic comment form must be completed by **8 p.m. ET, July 12, 2013**.

If you have questions please contact Ed Dobrowolski at ed.dobrowolski@nerc.net or by telephone at 609-947-3673.

Background Information

The SDT has been working on addressing the issues presented in the Standard Authorization Requests for Project 2010-17 Definition of the BES – Phase 2. The output of this work is shown in the first posting of the Phase 2 roadmap document.

In Phase 1, industry asked several questions regarding the technical justification of the threshold values shown in the definition. Due to the FERC mandated schedule for work on Phase 1, analysis of the various thresholds was delayed until Phase 2. At the direction of the NERC Board of Trustees, the NERC Planning Committee was tasked with analysis of threshold values as part of Phase 2 of the project. The NERC Planning Committee responded in its report entitled “Review of Bulk Electric System Definition Thresholds” dated March 2013, which has been posted on the Project 2010-17 webpage as part of the background material for this posting. The NERC Planning Committee report recommended that the following thresholds be maintained:

- 100 kV bright-line 1
- 10/75 MVA generation 2
- 100 minimum value for reactive devices N

The report did suggest possible changes to the local network exclusion regarding power flow and voltage levels. However, the SDT believes that such changes are contrary to the philosophy of local networks, would necessitate additional analysis workload, and would turn the evaluation from an operating timeframe to a planning environment. Therefore, the SDT is maintaining the status quo for the local network exclusion in Phase 2 with regard to threshold values and power flow issues.

FERC issued Order No. 773-A on April 18, 2013. In that order, FERC affirmed Order 773 and directed NERC to eliminate the 100 kV minimum in the local network exclusion, and to also make certain that generation interconnection facilities that are used to interconnect BES generation with BES transmission elements are determined to be BES elements.

The SDT has posed two questions in this posting addressing how it responded to those directives.

Question 1 below deals with the removal of the 100 kV minimum from the local network exclusion:

“**E3** - Local networks (LN): A group of contiguous transmission Elements operated at ~~or above 100 kV~~ ~~but~~ less than 300 kV that distribute power to Load rather than transfer bulk power across the interconnected system. LN’s emanate from multiple points of connection at 100 kV or higher to improve the level of service to retail customers ~~Load~~ and not to accommodate bulk power transfer across the interconnected system.”

Question 2 below deals with the proposed solution for generation interconnection facilities in the local network and radial system exclusions:

“**E3a** - Limits on connected generation: The LN and its underlying Elements do not include generation resources identified in Inclusions ~~I2 or I3~~ and do not have an aggregate capacity of non-retail generation greater than 75 MVA (gross nameplate rating);” and

“**E1b** - Only includes generation resources, not identified in Inclusions ~~I2 or I3~~, with an aggregate capacity less than or equal to 75 MVA (gross nameplate rating).” And

“**E1c** - Where the radial system serves Load and includes generation resources, not identified in Inclusions ~~I2 or I3~~, with an aggregate capacity of non-retail generation less than or equal to 75 MVA (gross nameplate rating).”

The SDT is proposing an equal and effective alternative to the issue of sub-100 kV loop analysis with respect to Exclusion E1. A threshold of 30 kV or less has been proposed for loops between radial systems when considering the application of Exclusion E1. The SDT used a three-step approach to determine the voltage level. As a first step, regional voltage levels that are monitored on major interfaces, paths, and monitored elements to ensure the reliable operation of the interconnected transmission system were examined to determine the lowest monitored voltage level. Next, power system analyses determined the maximum amount of power that can be transferred through the low voltage systems, when looped, under a worst case scenario at various voltage levels. Finally, examination of design considerations that the industry deploys to prevent loop flow through low voltage systems at the various voltage levels confirms that protection is implemented to prevent such flows through low voltage looped systems. Question 3 addresses this proposal.

Note 2 – The presence of a contiguous loop, operated at a voltage level of 30 kV or less, between configurations being considered as radial systems, does not affect this exclusion.

Question 4 deals with clarification on the topic of dispersed power resources as requested by industry in Phase 1. Based on Orders 773 and 773-A, the SDT has revised Inclusions I2 and I4 to address concerns raised by the Commission and to establish consistency in the treatment of BES generation resources:

“**I2** - Generating resource(s) and dispersed power producing resources, including the generator terminals through the high-side of the step-up transformer(s) connected at a voltage of 100 kV or above with:”

Dispersed power producing resources are small-scale power generation technologies utilizing a system designed primarily for aggregating capacity providing an alternative to, or an enhancement of, the traditional electric power system. Examples could include but are not limited to solar, geothermal, energy storage, flywheels, wind, micro-turbines, and fuel cells.

and,

~~**I4** - Dispersed power producing resources with aggregate capacity greater than 75 MVA (gross aggregate nameplate rating) utilizing a system designed primarily for aggregating capacity, connected at a common point at a voltage of 100 kV or above. Omitted.~~

Question 5 deals with all of the language clarifications made in response to industry comments which are listed here:

- **I1** – Semantic change from ‘under Exclusion E1 or E3’ to ‘by application of Exclusion E1 or E3’ to provide greater clarity as suggested by industry comments.
- **I2** – Splitting the inclusion into an ‘a’ and ‘b’ as suggested by industry to provide clarity.
- **I5** – Semantic addition to provide clarity as suggested by industry comments.
- **E3** – Semantic change replacing ‘retail customer Load’ with ‘retail customers’ to provide clarity as suggested by industry comments.
- **E3c)** - Semantic change replacing ‘a monitored Facility of’ with ‘any part of a’ to provide clarity as suggested by industry comments.
- **E4** - Semantic change to provide clarity as suggested by industry.

Question 6 is a generic question added to this list to accommodate any other industry concerns with the proposed Phase 2 definition.

Questions

You do not have to answer all questions. Enter comments in simple text format. Bullets, numbers, and special formatting will not be retained.

The SDT has asked one specific question for each specific aspect of the definition.

1. The SDT has deleted the phrase "... or above 100 kV but..." from the local network exclusion language (E3) in response to a FERC directive. Do you agree that the SDT has correctly addressed this directive? If you do not agree that this change addresses the directive, or you agree in general but feel that alternative language would be more appropriate, please provide specific suggestions in your comments.

Yes

No

Comments: The Directive was addressed by the revision, but generally Exclusion E3 does not recognize that regardless of how power gets to the load, it impacts the Bulk Electric System. The term bulk power is used in the opening sentence of E3. A definition of bulk power would lend credence and justification to E3, and the elimination of "or above 100 kV but".

The new Note 2 associated with Exclusion E1 and the changes to E3 have added ambiguity that did not exist before. The base definition does not address sub 100kV contiguous loops. The existing Inclusions do not include sub 100kV contiguous loops either. Note 2 clarifies that as long as the contiguous loop is below 30kV E1 still applies. E3 explains how any sub 300kV contiguous loop could be excluded as a local area network, but there is nothing in the definition that clearly states that contiguous loops operated below 100kV are considered part of the BES unless excluded by E3.

The 100kv threshold has been removed from the first sentence of E3, but it is inconsistent that the 100kV reference remains in the second part of the E3 exclusion. It is unclear what value the second sentence of the E3 exclusion provides, and its removal should be considered.

Under the premise that the very first paragraph of the BES Definition already establishes the bottom voltage threshold of 100kv, we agree with removing the mention of the 100kV bottom threshold in exclusion E3.

The version of exclusion E3 criterion (c) filed with FERC January 25, 2012 (RM12-6-000) requires a "Local Network" not to contain a monitored facility of a permanent Flowgate in the Eastern Interconnection, a major transfer path within the Western Interconnection, or a comparable monitored facility in the ERCOT or Quebec Interconnections, and is not a monitored facility included in an Interconnection Reliability Operating Limit (IROL). The definition became more vague by changing exclusion E3 criterion (c) from "a monitored Facility of a permanent Flowgate..."

to “any part of a permanent Flowgate...” and could allow for too broad a reading. The original language from Phase 1 of the BES definition regarding exclusion E3 criterion (c) provided more clarity and guidance on how to apply this exclusion. It is recommended that the original language from Phase 1 of the BES definition be reinstated. Facilities should be included in the BES only if the elements of the Facility are transferring power (flow) through a Flowgate, transfer path, or IROL.

The Phase 1 BES definition was approved by NERC after positive industry acceptance providing that Phase 2 would reconsider some of the thresholds proposed in Phase 1. The important 75MVA generation threshold limit was included. The FERC requested changes now limit the possibilities for exclusion: 1) limitation on the possibility of radial exclusion because of looping below 100 kV; 2) refusal of radial or local exclusions when there is at least one generator above 20 MVA. Those limitations for exclusion go in the opposite direction to what industry expected. NERC must realize that the definition will be applied to entities not under FERC jurisdiction. It is important that NERC consult Canadian jurisdictions about the BES definition.

2. As identified in the FERC directive, the SDT has revised the local network (Exclusion E3) and radial system (Exclusion E1) exclusions so that they do not allow for the utilization of these exclusions for generation interconnection facilities that are used to interconnect BES generation identified in the generation inclusion (Inclusion I2) with BES transmission elements. Do you agree that the SDT has correctly addressed this directive? If you do not agree that this change addresses the directive, or you agree in general but feel that alternative language would be more appropriate, please provide specific suggestions in your comments.

Yes

No

Comments: I2 does not include “non-retail” generation which is inconsistent with E1 and E3. E1b, c, and E3a contain redundant statements regarding the 75MVA generator threshold. These statements should be corrected for clarity and consistency.

For Simple E1 Radial System Exclusions--The Drafting Team application of this FERC directive is clear for simple E1 Radial System Exclusions. Any tie-line connected radially to the BES and operated at 100kV or above connecting I2 or I3 generation (aggregating to more than 75MVA) is part of the BES. However, beyond this simple configuration the application of the tie-line directive is less clear.

For the More Complex E1 Radial System Exclusions--More complex applications of the tie-line directive under the proposed BES Definition are less clear. Consider that Inclusion I2 states the tie-line includes "... the generator terminals through the high-side of the step-up transformer(s) connected at a voltage of 100 kV or above..." It could be argued that this was intended to apply to a short line or bus connection between the generator and the generator step-up unit. But in reality it could be a long connection. Regardless, a fault can occur on any length of line or bus. Application of the tie-line directive is less clear when there are multiple feeders and transformations between the generating resource and the BES which include sub-100kV operating voltages. For example, a GT with a 13.8kV output feeds local distribution. This local distribution is also served by a 69-to-13.8kV step-down transformer that is fed by a 69kV sub-transmission feeder supplied by a 138-to-69kV transformer connected to the BES by a 138kV feeder serving multiple step-down transformers to load. This Radial System has only one connection to the BES at 138kV. What facilities are covered by the tie-line directive, either the entire path from "... the generator terminals through the high-side of the step-up transformer(s) connected at a voltage of 100 kV or above" or only the portion of the 138kV feeder from the high-side terminals of the 138-to-69kV step-down transformer to the BES?

For the E3 Local Network Exclusion--Applying the tie-line directive within a Local Network could be problematic. The proposed wording introduces issues similar to those involving Cranking Paths from Black Start units. Local Networks by the definition "emanate from multiple points of connection at 100 kV or higher." Defining a single tie-line through the Local Network presents problems. Is the tie-line the shortest path geographically or electrically? Does the tie-line directive suggest single or multiple paths to the BES? The CIP drafting team recognized this problem and defined the path, eliminating Regional or Entity discretion and avoiding substantial ambiguity and confusion. Following the CIP Drafting Team example, suggest adding the following wording:

Note 3: The BES tie-line is defined as the portion of the single shortest contiguous path operated at 100kV or above from the I2 or I3 resource to the BES. The Radial System or Local Network excluded must be defined so that it does not include a BES tie-line. Portions of the tie-line path operated below 100kV are not part of the BES. Application of this note does not extend to tie-line facilities operated below the 100kV core definition.

3. The SDT has proposed an equally effective and efficient alternative to the Commission's sub-100 kV loop concerns for radial systems by the addition of Note 2 in Exclusion E1. Do you agree with this approach? If you do not support this approach or you agree in general but feel that

alternative language would be more appropriate, please provide specific suggestions and rationale in your comments.

Yes

No

Comments: Exclusion E1 provides a floor (30 kV threshold) for which an entity does not have to consider the loop in its determination of a radial system. Due to the international nature of the ERO, consideration must be given to what the various Provinces consider to be “distribution level”, and any proposed revision should recognize this dissimilarity. In addition, in the United States various state representatives have cited jurisdictional issues associated with lowering the threshold to 30 kV. This also impacts the 100 kV bright-line threshold definition. The 30kV threshold as currently written is too restrictive.

In a similar way as 100 kV is the delineator between the medium and high system voltage classes in the American National Standards Institute (ANSI) standard on voltage ratings (C84.1), the voltage threshold in note 2 of exclusion E1 should be based on well defined standard system voltage classes to better correlate to operational and system design considerations and practices. The Exception Procedure could be used to include lower (than 100 kV; bright line) voltage systems in the BES envelope when interactions between these systems and the BES are deemed critical to reliable operations in their local or regional area.

The demarcation point between transmission and distribution may be different in non-FERC jurisdictions, such as the Canadian Provinces. For example, in Ontario, legislation establishes 50kV as the technical boundary line between transmission and distribution. In establishing voltage thresholds, NERC needs to consider non-U.S. legislated demarcation points, and the standard development process must make allowances for such regulatory and/or jurisdictional differences. The establishment of the voltage floor for the E1 exclusion as currently written is inconsistent with the language and structure of the legislative framework in Ontario. The Exception Process is not appropriate to determine the jurisdictional issue of whether facilities are part of the Bulk Electric System.

Note 2 should be modified to read as follows:

Note 2 – The presence of a contiguous loop, operated at a voltage level below the applicable cut-off between configurations being considered as radial systems, does not affect this exclusion. The applicable cutoff is 30kV or less, unless deemed otherwise by regulatory authority.

A technical justification is not required where a Provincial jurisdictional finding is applicable.

4. The SDT has revised the generation resources and dispersed power resources inclusions (Inclusions I2 and I4) in response to industry comments and Commission concerns. Do you agree with these changes? If you do not support these changes or you agree in general but feel that alternative language would be more appropriate, please provide specific suggestions in your comments.

Yes

No

Comments: It should be considered that dispersed generators that are represented to the marketplace or modeled in study cases as 20MVA or higher should be included in the definition just as a single traditional generating unit of 20 MVA is included. By removing I4, the aggregating portion of the inclusion has been muddled. Suggest adding I2-c to include dispersed resources that are aggregated and modeled at 20MVA or higher. This would add clarity and consistency to the definition.

The impact of the proposed response to Commission directives (and the directives themselves) in effect bring wind generation collector systems and any other aggregation system for other resource technologies into the definition of Bulk Electric System. Recommend that there be an exclusion for wind generation collector systems which are radial in nature and do not serve any retail load provided adequate protection for the BES via protective systems installed at the point of interconnection. Bringing many thousands of 1-2 MW generators directly into the reliability regime of the ERO is not necessary, or justified.

In plants with an aggregate rating greater than 75 MVA, the individual generators should be treated in the same manner as if they were each a stand-alone facility. If the individual generator is at or below 20 MVA in a stand-alone facility it would not be included in the BES and the owner of such a facility would not even have to register as a generator owner. That same size generator in an aggregated facility should be treated the same and it should be excluded from the BES. The portion of the facility at which the 75MVA or greater aggregation occurs should be where the BES boundary should be occurring.

Below is a sketch to demonstrate the concept:

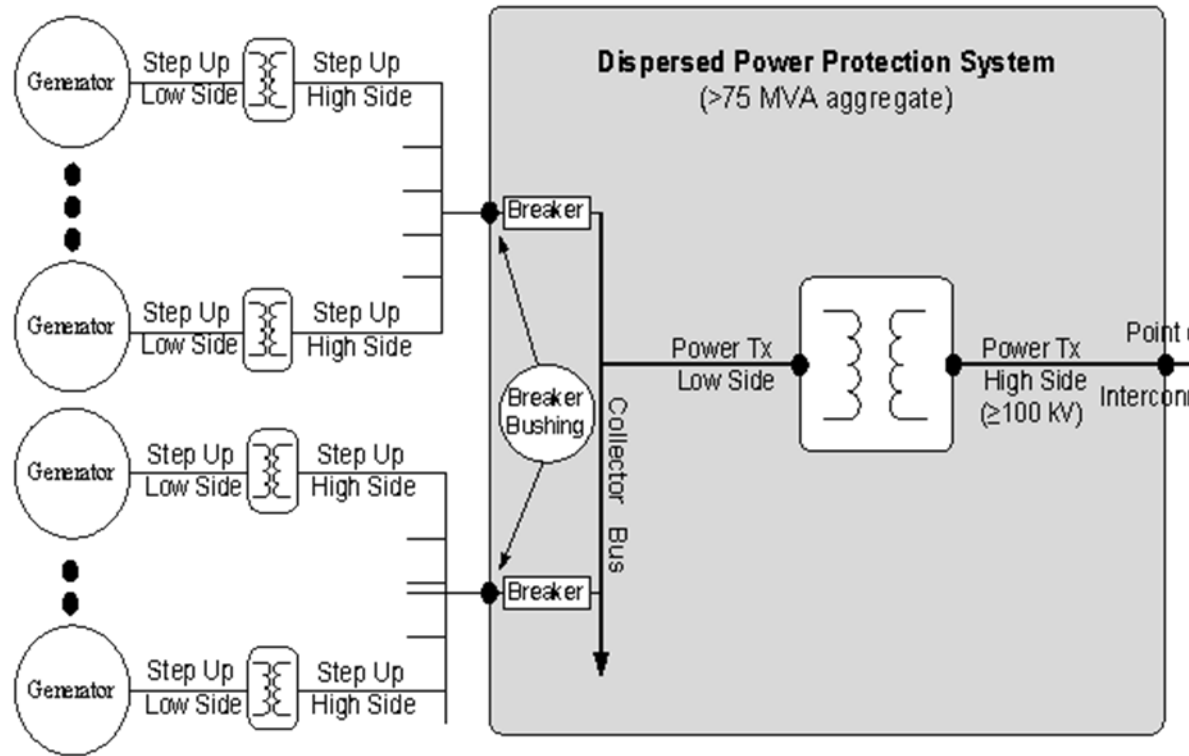

Figure 1

See Figure 1.

From FERC Order 733A beginning at paragraph 50, “we direct NERC to modify the exclusions pursuant to FPA section 215(d)(5) to ensure that generator interconnection facilities at or above 100 kV connected to bulk electric system generators identified in inclusion I2 are not excluded from the bulk electric system”. To that end, I2 should be revised to read:

I2 - Generating resource(s) and dispersed power producing resources, including ~~the generator terminals through the high side of the step-up transformer(s) connected~~ their power delivering assets operated at a voltage of 100 kV or above with:

5. The SDT has made a number of clarifying changes to language in response to industry comments as follows: (a) I1: Change 'under' to 'by application of'; (b) I2: Split out the inclusion to clearly show that it is an 'or' condition; (c) I5: Add 'unless excluded by application of Exclusion E4'; (d) E3: Change '... retail customer Load...' to 'retail customers'; (f) E3c: Change '... a monitored Facility of a ...' to '... any part of a...'; (g) E4: Add the phrase 'installed for the sole benefit of'. Do you agree with these changes? If you do not support these changes or you agree in general but feel that alternative language would be more appropriate, please provide specific suggestions (using the letter of the change) in your comments.

Yes

No

Comments: For Exclusion E4 Reactive Devices - The drafting team agreed that use, and not ownership, should dictate the disposition of reactive devices. Reactive devices used to support retail customer loads, and not used in day-to-day operations for BES voltage control for either steady state or contingency operations, may be excluded from the BES regardless of ownership. Devices need not be owned by "a retail customer" as a prerequisite for exclusion. Reactive devices owned by others, such as a Transmission Owner, and installed solely for the benefit of retail customer load should also qualify for exclusion. The proposed wording still carries remnants of the previous retail customer concept. It refers to a singular customer. Yet, reactive devices may be installed to benefit a group of retail customers collectively referred to as retail load. Suggest revising E4 to either read:

E4--Reactive Power devices installed for the sole benefit of retail customers.

or

E4--Reactive Power devices installed for the sole benefit of retail load.

6. Are there any other concerns with this definition that haven't been covered in previous questions and comments?

Yes

No

Comments: The specifics of system configurations and applications in the Inclusions and Exclusions should be reviewed to be made less complex. If they are not simplified they can be expected to generate a large number of requests for exclusion consuming resources in regional processing and at the ERO. As an alternative, an updated, conforming Guidance Document clarifying the intent and containing explicit explanations and one-line diagram examples should be provided. The version previously posted does not conform to the Phase 2 changes proposed.

Phase 2 of the BES definition process was supposed to address the 100kV threshold, the generator thresholds and the reactive resource thresholds for inclusion or exclusion. No formal studies have shown that these numbers are the correct numbers for this definition. The studies provided under Phase 2 had no more technical justification than those discussions by the Standard Drafting Team in Phase 1. Being able to have that technical justification provides the support necessary to maintain a reliable transmission system and provides a basis for analysis of reliability by industry participants.

Based on FERC orders 773 and 773-A and NERC's response to those orders, the value of Note 1 under E1 has been diminished and suggest it be removed. It must be considered that industry has typically considered the terms 'network' and 'contiguous' to exclude elements or facilities that contain a normally open device (switch, breaker, disconnect, etc.) between them.

- 1) NERC must consider that any new or changes to standards as a result of FERC directives that apply to load reliability and load supply continuity are limited to the FERC jurisdiction only. For example, in Canada, local load reliability requirements are under the authority of local regulators such as the OEB in Ontario.
- 2) The Implementation Plan does not conflict with the Ontario regulatory practice with respect to the effective date of the standard. It is suggested that this conflict be removed by appending to the effective date wording, after "applicable regulatory approval" in the Effective Dates Section of the Implementation Plan, the following:

" , or as otherwise made effective pursuant to the laws applicable to such ERO governmental authorities."

The same changes should be made to the first sentence in the Effective Date Section on page 2 of the Definition document.

The main concern about the Phase 2 definition is that it reduces more than the Phase 1 definition by the possibility of exclusions, and that no proper technical analysis had been given to justify or reduce the proposed threshold. FERC's request should not force obligations on non-United States jurisdictions. NERC must consult with and treat both United States and non-United States jurisdictions equally.