

Rinnai

Operation & Installation Manual RF1800

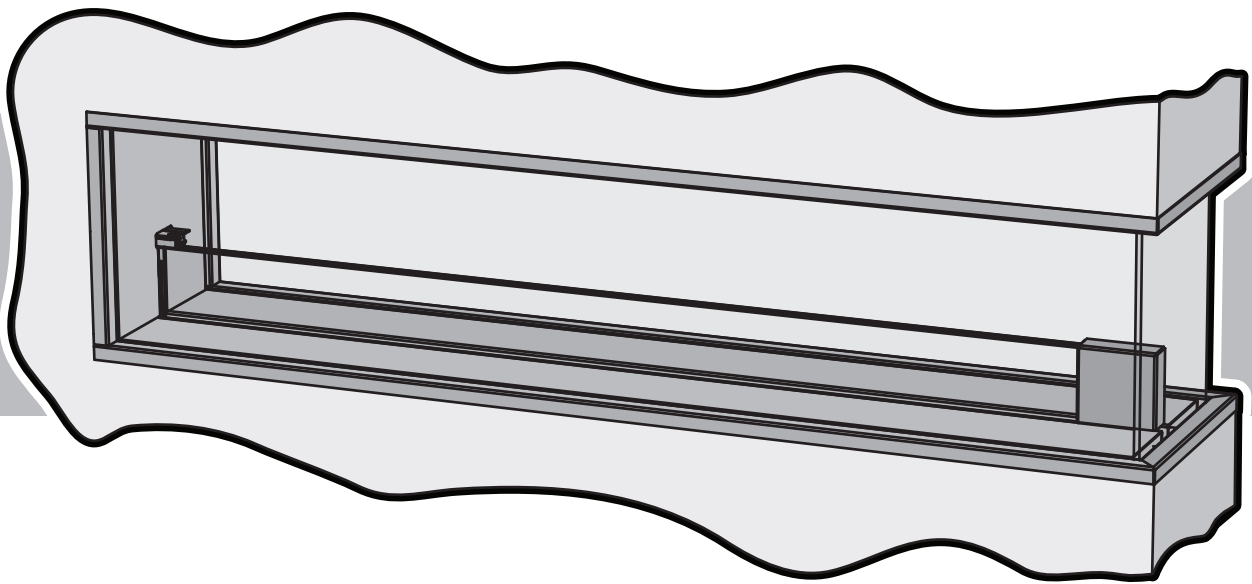

This appliance shall be installed in accordance with:

- Manufacturer's Installation Instructions
- Current AS/NZS 5601 AS/NZS 3000
- Local Regulations and Municipal Building Codes including local OH&S requirements

This appliance must be installed, maintained and removed by an Authorised Person.

For continued safety of this appliance it must be installed and maintained in accordance with the manufacturers instructions.



N10378



The Australian
Gas Association
All Rinnai gas products
are A.G.A. certified.

Congratulations on the purchase of your RF1800 Decorative Gas Flame Effect appliance
We trust you will have many years of enjoyment from your purchase.

THIS MANUAL CONTAINS IMPORTANT INFORMATION. FOR SAFETY PLEASE READ
CAREFULLY BEFORE PROCEEDING WITH ASSEMBLY, INSTALLATION AND OPERATION
OF YOUR NEW FLAME FIRE AND GAIN A FULL UNDERSTANDING OF THE APPLIANCE.

OPERATION TABLE OF CONTENTS

Before You Start	2
Safety	3
Safety Devices	4
Appliance Features	5
Operation Instructions	5
Operational Safety	5
Power Failure	5
Cleaning	6
When to call for Service	6
Service	6
Installation Table of Contents	7
Contacts	22

BEFORE YOU START

INSTALLATION REQUIREMENTS

This appliance **MUST BE** installed by an authorised person.

The installation **MUST** conform to local regulations.

The installation **MUST** also comply with the instructions supplied by Rinnai.

Service and removal **MUST BE** carried out by an authorised person.

CERTIFICATION

The Rinnai RF1800 has been certified by the Australian Gas Association.

The Certification Number is shown on the appliance dataplate.

No parts or functions are to be modified or permanently removed from the heater.

Please keep these instructions in a safe place for future reference.

CARTON CONTENTS

The main RF1800 engine components are supplied in a crate, components for additional installation methods are packed separately. The following table lists the contents for each component package, ensure that the components listed for the installation method being installed are present before proceeding with the installation.

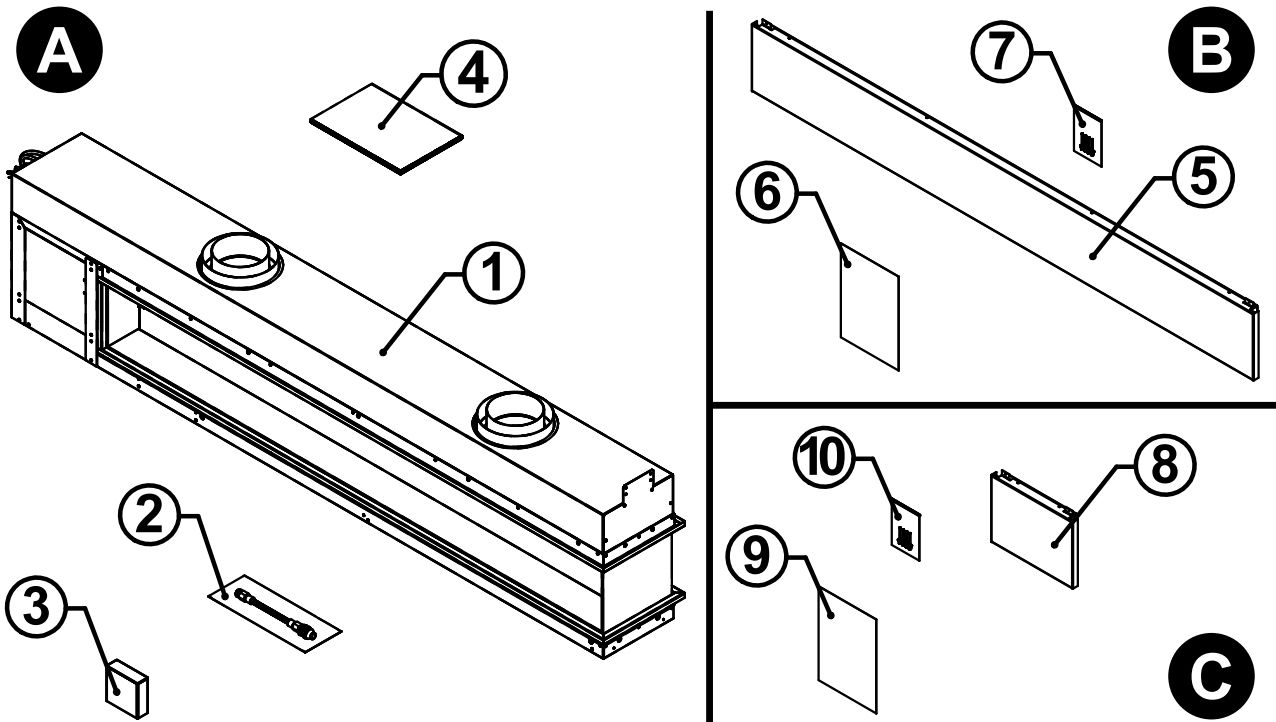

Item	Description	Contents		
		A	B	C
1	Rinnai RF1800 gas fire engine	•		
2	Gas connection kit: 200mm 3/8 Flexi tube with plug and 3/8" - 1/2" reducing flare connector	•		
3	Burner end cap	•		
4	This Operation and Installation Manual	•		
5	Rear reflector option for corner or fully recessed installation		•	
6	Instructions for reflector panel installation		•	
7	Rivet pack		•	
8	End reflector option for through wall or fully recessed installation			•
9	Instructions for reflector panel installation			•
10	Rivet pack			•



DO NOT OPERATE THIS APPLIANCE WITHOUT READING AND UNDERSTANDING THESE INSTRUCTIONS.

Taking time to familiarise yourself with the appliance's features and operation will allow you to get the most out of your appliance for years to come.

Please keep these instructions for future reference. Failure to comply with these instructions could result in a fire or explosion, which could cause serious injury, death or property damage.

Improper installation, adjustments, service or maintenance can cause serious injury, death or property damage. Such work must be performed by authorised personnel.

The appliance must be installed in accordance with the local gas and electrical authority regulations.

Flue terminal must always vent directly to outdoors.

DO NOT extend the flue vertically or horizontally in ways other than prescribed in the appliance manufacturers' installation instructions.

For information on gas consumption, see data plate on the appliance.

This appliance must not be installed where curtains or other combustible materials could come into contact with it. In some cases curtains may need restraining.

When considering installation ensure minimum clearances as in the following drawing are adhered to for both sides of the appliance:

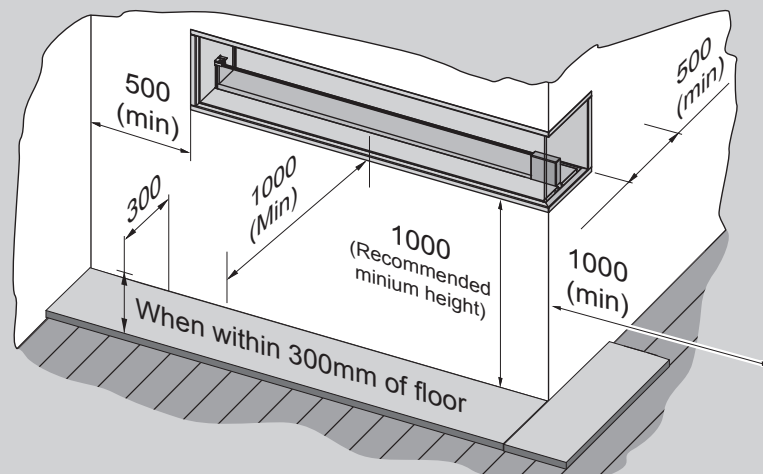

This appliance is not intended for use by persons (including children) with reduced physical, sensory or mental capabilities or lack of experience and knowledge, unless they have been given supervision or instruction concerning use of the appliance by a person responsible for their safety.

The appliance is not intended for use by young children or infirm persons without supervision.

Young children must be supervised when in the vicinity of this heater while it is in operation.

For protection of young children or the infirm a secondary guard is required.

If the supply cord is damaged or requires replacing, it must be replaced by the manufacturer or the manufacturer's agent or similarly qualified person in order to avoid a hazard.

DO NOT connect to an LPG Gas cylinder indoors.

A dedicated 240 V earthed 10 Amp power point must be used with this appliance.

DO NOT modify this appliance. Modifying from original specifications may create a dangerous situation and will void your warranty.

ONLY THE FLUE COMPONENTS SPECIFIED BY RINNAI MUST BE USED.

Unpack the heater and check for damage. **DO NOT INSTALL A DAMAGED HEATER.** If the heater is damaged, contact your supplier for advice.

Before installing the heater, check the label for the correct gas type (refer rating plate, inside the appliance). Refer to local gas authority for confirmation of the gas type if you are in doubt.

SAFETY



DO NOT sit or lean against the heater.

DO NOT post or allow children to post articles into the heater.

DO NOT cover or place articles on this heater.

DO NOT operate / install this heater in areas where painting is taking place, or in places such as hairdressing salons, where there may be fluff and dust, and where aerosols are used.

DO NOT place articles on or against this appliance.

DO NOT use or store flammable materials near this appliance. Keep flammable materials away from heater.

Combustible materials **MUST NOT** be placed where the heater could ignite them.

DO NOT spray aerosols in the vicinity of this appliance while it is in operation. Most aerosols contain flammable substances which can be a hazard if used near this appliance when it is in use.

DO NOT use power boards or double adaptors to operate this appliance. The heater **MUST NOT** be located below a power socket-outlet.

DO NOT place containers of liquid on top of the heater. Water spillage can cause extensive damage to the appliance and create an electrocution hazard.

DO NOT CONNECT TO AN LPG GAS CYLINDER INDOORS.

Turn the heater 'OFF' when not in use.

DO NOT unplug the heater while it is in operation.

When the heater is operated for the first time or after long periods of non use a slight odour may be emitted, this is normal. However if odours persist switch 'OFF' the appliance and contact Rinnai.

Appliances incorporating a live fuel effect and designed to operate with luminous flames, may exhibit slight carbon deposits.

This is primarily a decorative appliance and has not been designed as a space heater.

NOT INTENDED FOR FIREPLACE INSERT

WHAT TO DO IF YOU SMELL GAS

DO NOT try to light any appliances.

DO NOT touch any electrical switches: do not use any phone in your building

Immediately close the shut-off valve at the gas meter or bottles

Call an authorised service technician

SAFETY DEVICES

Electrical Fuse:

The electrical circuits are protected by a fuse. When the fuse blows, the heater will not operate. The fuse must be replaced by an authorised person.

Flame Failure Sensing System:

This device automatically cuts off the gas supply to the heater in the event of a flame failure.

Power Failure:

In the event of a power failure or power cut, the gas valves will automatically close. Refer to "Electrical Supply" on page 10 for further details.

APPLIANCE FEATURES

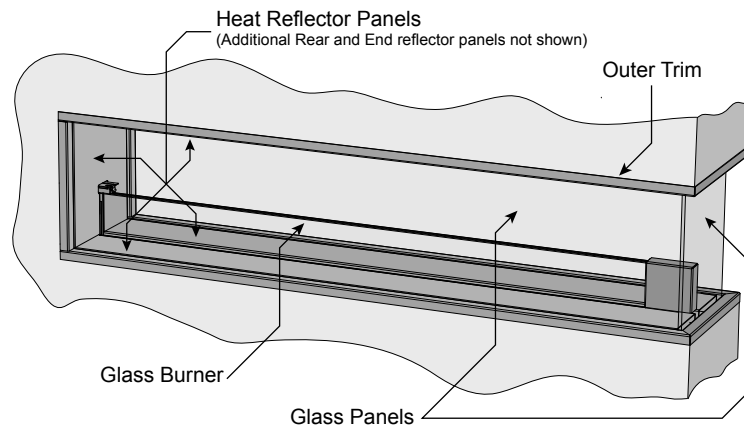

OPERATION INSTRUCTIONS

To operate your appliance for the first time, ensure that the gas supply is on and that the appliance has been tested and commissioned by the installer (refer to the “Commissioning Checklist” on page 20).

Your appliance should have been installed with a separate isolating wall switch mounted on a nearby wall and may also have a start button connected to a relay*.

Turn the wall switch to the on position and within a few seconds you will hear a sparking sound and gas will start to flow through the burner. Once a flame is established the spark ignition will stop.

If the appliance fails to ignite within about 5 seconds, the gas will stop flowing and the gas control will “lock out”. This is most likely when the appliance has just been installed or has not been used for some time. Turn the wall switch off and the on again and press the start button and the cycle will start again.

If the appliance fails to ignite after 4 attempts then consult the trouble shooting section on page 20 or contact your installer or an authorised service person to arrange a service call.

OPERATIONAL SAFETY

This appliance is factory tested and the installation **MUST BE** tested by an authorised installer. You should not experience any odour from your appliance other than initial burn off smell the first time it is used. Should any odour persist after the initial burn in, turn off the gas supply and arrange for an authorised person to make a service call.

This appliance has a flame failure safety system which ensures that in the event of an ignition failure, gas supply failure or flame being extinguished for any reason, the appliance will shut down. The appliance will attempt to re-start automatically.

Lock Out

If the appliance fails to re-ignite then the appliance will “Lock Out” and will need to be re-set manually. This is done by turning the power ‘OFF’ at the wall switch.

After manual reset wait at least 10 seconds before attempting to restart the appliance and if the appliance still fails to ignite after 4 attempts then turn off the power and refer to the trouble shooting section on page 20.



This appliance burns with a real flame and as such there are considerations to be made to ensure the safety of children and the infirm. In such circumstances a fire guard should be secured in front of the appliance.

Furniture and other objects must not be placed within 1 metre of the appliance.

POWER FAILURE

In the event of a power failure, your appliance cannot be operated until power is restored.



If a power failure occurs while the appliance is in operation and if the wall switch is left in the ‘ON’ position, when the power is restored the appliance will then automatically restart.

*** Provision of a latched relay (see page 21 for details) or other automated power supply cut off can be used to prevent the appliance from restarting.**

CLEANING

Regular cleaning of your appliance is important to keep it looking its best. Some points on cleaning:



DO NOT attempt to clean appliance while in operation or when hot.

DO NOT spray cleaners onto or around the burner as the liquid can get between the glass panels and cause water spotting.

- It is important to keep the burner free from debris such as dust, insects and anything else that could cause a blockage. Carefully use a vacuum cleaner to clean the gap between the two glass panels that make up the burner.
- The burner and the glass panels can be cleaned using household glass cleaners, when doing so it is best apply cleaners by cloth rather than by spray. **DO NOT** spray cleaners onto or around the burner.
- The stainless steel reflectors and trims can be cleaned using standard household stainless steel cleaners. Take care not to scratch the steel or spray cleaners onto the burner

WHEN TO CALL FOR SERVICE

There are a few points to look out for that could indicate that your appliance requires a service call.

- If soot starts to form on any of the panels (trim or glass).
- If you can smell gas, regardless of whether the appliance is going or not.



There can be a brief smell of gas as the appliance is going through the ignition sequence, however this should soon stop once the appliance has started.

- If there is excessive noise or explosive ignition as the burner lights, this could be due to blocked burner ports.
- If the flames change shape or colour. Under normal operation the flames will be a bright, luminous, yellow colour. If they become a dark, streaky, orange colour, or a very blue colour, this could indicate a problem.

Abnormal Flame Pattern

- If the flame looks abnormal. Signs of abnormal flame operation could be:
 - A very short flame that does not reach across to the burner.
 - A very long flame that reaches far beyond the flame burner or long yellow flames.
 - A roaring noise when the appliance in operation or the flame “lifting off” from the burner.
- If there are large soot deposits that keep building up on the burner or panels.
- If there is excessive noise or explosive ignition as the burner lights, this could be due to blocked burner ports.
- If a smell of flue gas continues after the appliance has been operating for at least 10 minutes. This could indicate a blocked flue or other problem. This smell is acceptable during the first few minutes as the flue heats up and starts to draw.
- If the flames change shape or colour. When the appliance first starts the flames will tend to be quite blue for a few minutes but will change to a more yellow/orange colour as the system heats up, this is normal, but if the flames either stay very blue, or turn a dark, streaky orange colour, this could indicate a problem. Contact Rinnai for advice.

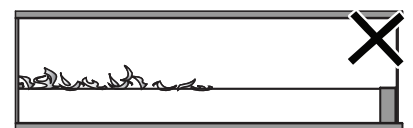

SERVICE

In order for your appliance to give years of comfort and enjoyment, it is recommended that it is serviced on an annual basis by a licensed service gas-fitter. Please refer to the back of this manual for contact details.

Disconnect the power and gas supply to the appliance before proceeding with the service.

Power Cord Replacement

If the power cord becomes damaged, replacement is to be by an authorised person only using a manufacturer supplied part.

INSTALLATION TABLE OF CONTENTS

Operation Table of Contents	1
Installation Safety	8
Specifications	9
Dimensions	9
Gas & Electrical Supplies	10
Clearances, Mantels, Surrounds, Recesses & Hearths	11
Ventilation	12
Flue Requirements	12
Engine Installation	14
Appliance Gas Connection & Commissioning	18
Final Checks	20
Trouble Shooting	20
Commissioning Checklist	20
Wiring Diagrams	21
Contacts	22

INSTALLATION SAFETY



This appliance must be installed by a suitably qualified person in accordance with local codes and AS/NZS 5601

This is primarily a decorative appliance and has not been designed as a space heater

This appliance has been tested to AS 4558

DO NOT operate this appliance without reading and understanding these instructions first

This appliance is designed for installation into a timber framed construction and new or existing masonry installations

NOT INTENDED FOR FIREPLACE INSERT

Only the approved flue components specified by Rinnai **MUST BE** used

This appliance must be installed into a well ventilated room in accordance with AS/NZS 5601

This appliance is designed for indoor installation only; **NOT TO BE INSTALLED OUTDOORS**

Rinnai is not responsible for incorrect or improper installations

All installations must be carried out by authorised personnel

Be sure to complete the installer details section of the user guide before signing off the installation

DO NOT place articles on or against this appliance

DO NOT store chemicals or flammable materials, or spray aerosols near this appliance

DO NOT operate with panels, covers or guards removed from this appliance.

DO NOT modify this appliance

SPECIFICATIONS

Models:	RF1800L(N/P) "Left handed model", RF1800R(N/P) "Right handed model"
Gas Types:	Natural Gas Propane Gas
Description:	Indoor Decorative Appliance
Flue:	2x 150 mm stainless steel inner/ 200 mm galvanized steel outer Minimum of 2.4 metres of flue, 3.6 metres if off-set bends are used
Flue Cowl:	AGA approved 150 mm or 200 mm Flue Cowl(s) (dependant of flueing method)
Gas Connection:	3/8" BSPF Gas Flare onto gas control
Power:	230/240V AC 50hz, 1 Amp
Burner:	Bunsen type atmospheric
Gas Control:	SIT 840 with SIT 579. 402 DBC
Ignition:	Electronic
Flame Monitoring:	Flame rod
Control:	Isolating switch



For all other specifications refer to the appliance data plate

DIMENSIONS

Engine

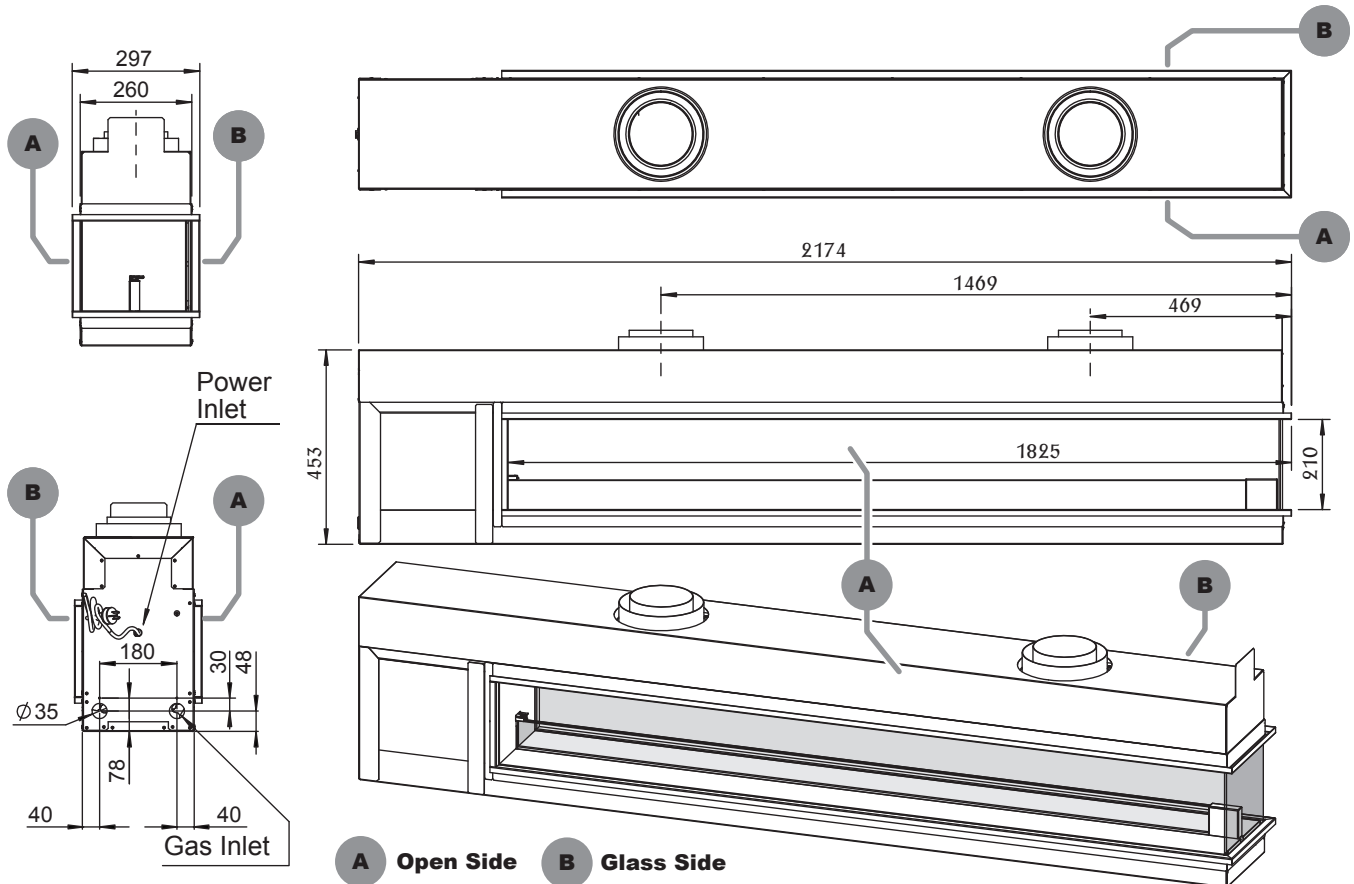

The drawings above are for the Left handed version of this appliance. A right hand version is also available, for which the dimensions are the same yet reversed.



The following installation instructions are for a left handed version of the appliance, when installing the right handed version dimensions and other references will need to be reversed.

GAS & ELECTRICAL SUPPLIES

Gas Supply

A suitable gas supply needs to be provided to the Left hand end of the appliance at the lower front corner of the installation cavity. The pipe sizing should be calculated to supply at least 40 MJ/h

Allow sufficient pipe penetration to make the connection as shown right.



The gas inlet access point for this appliance is provided with a set of flaps to allow consumer piping with fittings attached to be passed through for connection.

For vermin control ensure that these flaps are closed again once the piping has been installed.

Use the supplied gas connection kit (200mm 3/8 Flexi tube with plug and 3/8" - 1/2" reducing flare connector) to connect the appliance to the consumer piping.

Electrical Supply

The appliance is supplied with a power lead (approx. 1.8m long). This needs to be connected to an isolating wall socket within the cavity and connected to an isolating wall switch, preferably located to the left of the appliance, facing into the room, not inside the framing cavity.



If a power failure occurs while the appliance is in operation and if the wall switch is left in the 'ON' position, when the power is restored the appliance will then automatically restart.

Provision of a latched relay (or other automated power supply cut off) can be used to prevent the appliance from restarting, refer to "Wiring Diagrams" on page 21 for further details in regards to latched relays.

This supply is used to isolate all power from appliance. The power cord is designed for a 230/240V AC 10 amp supply. Electrical connections must be in accordance with AS/NZS 3000 and installed by an authorised person.

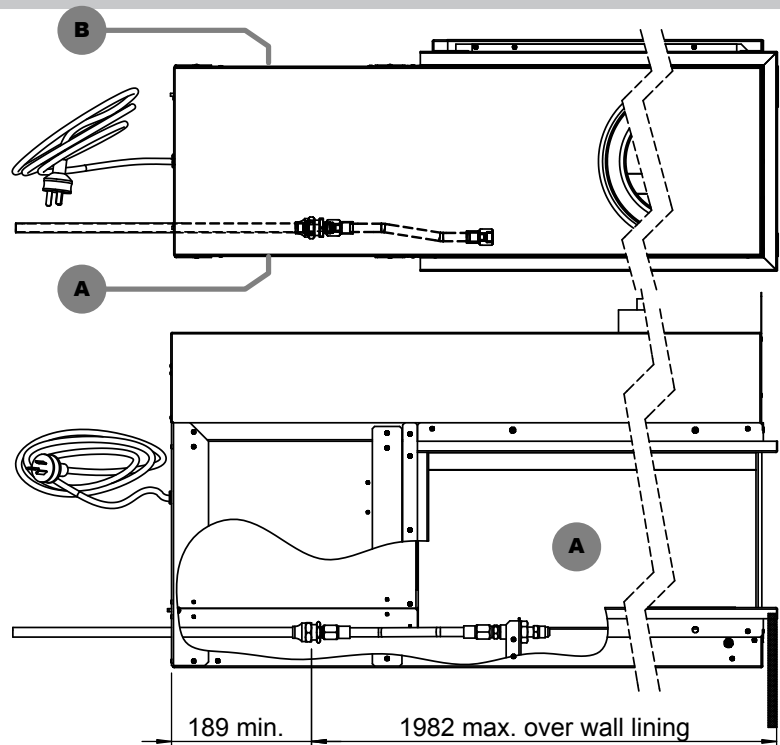

A Open Side

B Glass Side

This access hole is only used when installing a right handed appliance

Open the hole cover plates to fit consumer pipe and flexi tube

48

58 from finished lining

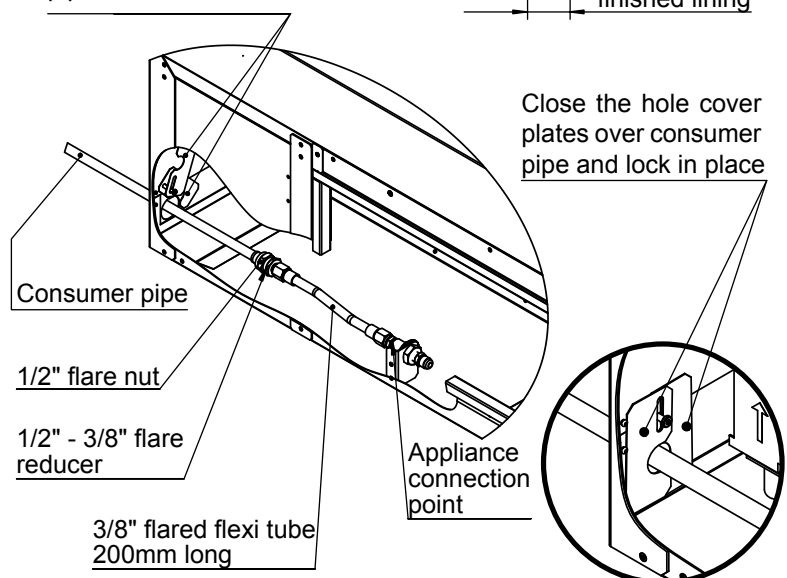

Close the hole cover plates over consumer pipe and lock in place

Consumer pipe

1/2" flare nut

1/2" - 3/8" flare reducer

3/8" flared flexi tube
200mm long

Appliance connection point

CLEARANCES, MANTELS, SURROUNDS, RECESSES & HEARTHES

Clearances

The appliance must be installed with the shown minimum clearances to combustible materials.

Mantles

A timber mantel may be installed above this appliance but must be within the grey area as shown here.

Timber Surrounds

As with mantels when a timber surround is to be fitted, ensure it complies with minimum timber clearances of 300mm above and 150mm to each side.

Recesses

If the appliance is to be installed into a recess the recess must comply with the limitations shown right.



The same limitations apply to the sides of the appliance.

TV or Ornamentation Above The Heater



The installation of electrical appliances above and in the vicinity of the heater such as, but not limited to, Plasma TV, LCD TV, Home Theatre Screens, Speakers, etc. must comply with their manufacturers' instructions.

It is the responsibility of the installer/end-user to check the installation instructions of these items and to ensure the location is suitable.

This caution also extends to, but is not limited to, ornaments such as: Paintings, Prints, Photographs, Tapestries, Mirrors, Stuffed Animals, etc.

Rinnai does not take any responsibility for any damage occurring to any items installed above and in the vicinity of the heater.



Use either a shelf or mantel below the TV or ornament or alternately you can construct a recess to mount TV or ornament on.

Check the manufacturers installation instructions for these items and ensure the recess is suitable.

Hearths

Although a solid hearth is not required, if the appliance is to be installed within 300mm of the floor, it is recommended that protection is given to any flooring surface directly in front of the unit as the appliance produces a large amount of radiant heat and this might cause damage to flooring and furnishings that are too close.

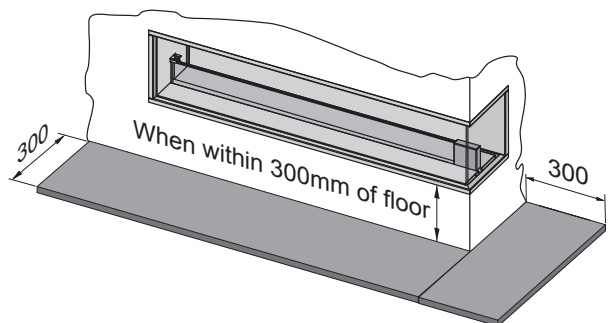
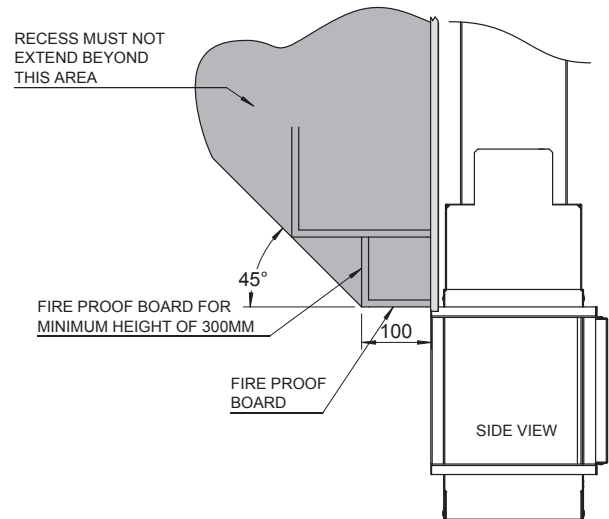
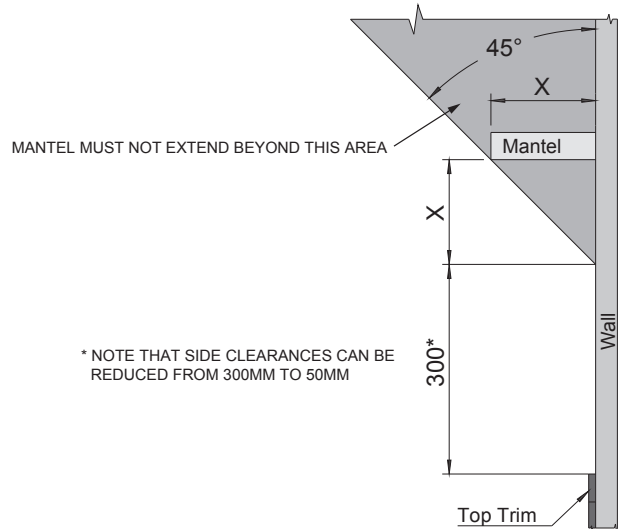
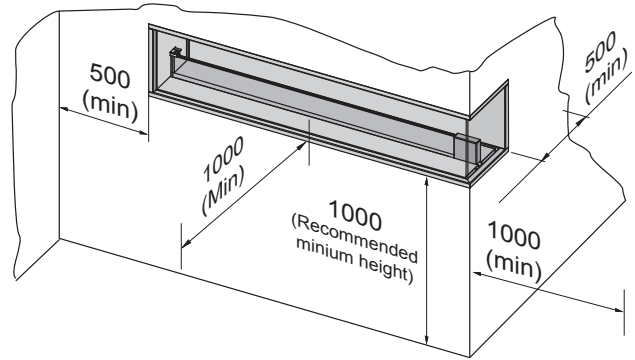

VENTILATION



This appliance is a decorative flame effect appliance, the space or room in which the unit is installed must have adequate fixed ventilation compliant with the requirements of AS/NZS 5601.

For Decorative Gas Log Fires this requires that one or more openings with a combined free ventilation area of not less than 314 cm² shall be provided for each appliance.

The opening may be provided by any of the following options, provided that there is a ventilation path to outside that is unobstructed by building material or insulation:

- Directly through an outside wall (preferred option).
- Through to an outside wall but offset.
- Into a cavity ventilated to outside.
- Into an underfloor space ventilated to outside.
- Into a roof space ventilated to outside.

FLUE REQUIREMENTS



ONLY the Rinnai flue components described in this manual are to be used with this appliance.

The installation of the flue system **MUST** comply with the requirements of AS/NZS 5601.

Examples of the available flue component configurations are shown below.

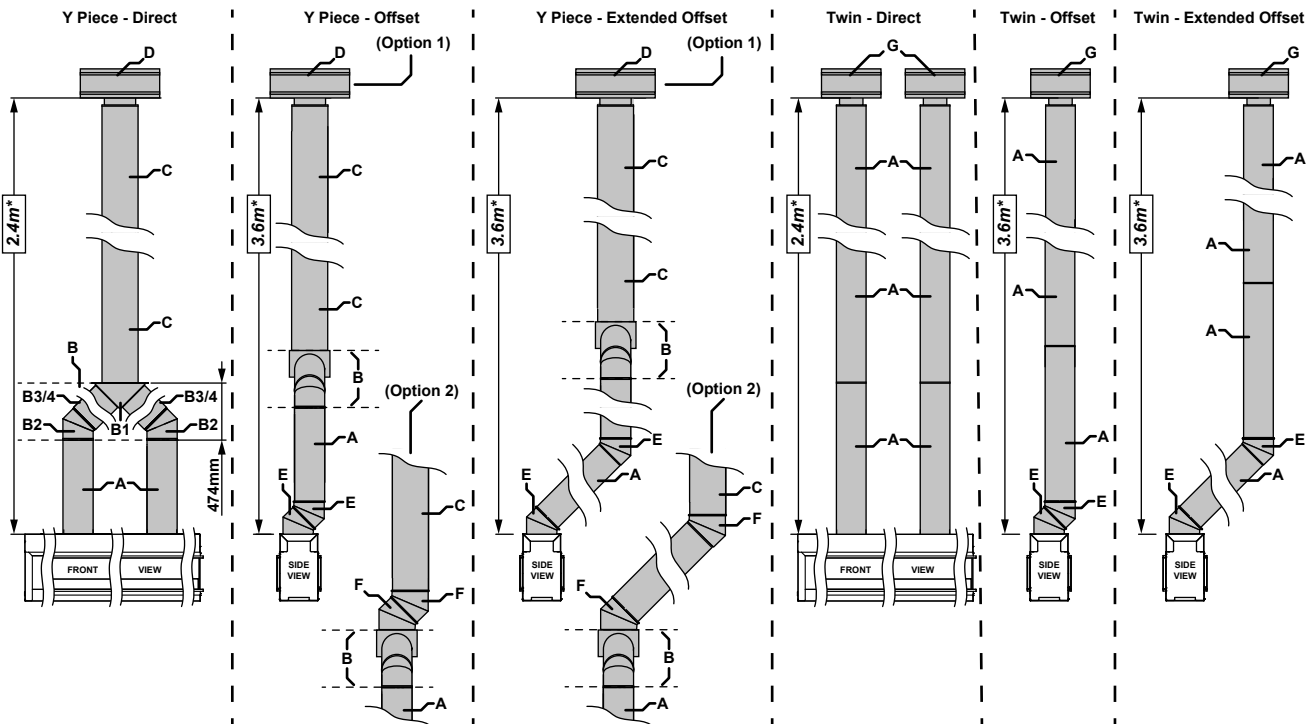

* This is the minimum flue height for the configurations as shown, for additional bends increase the flue height in accordance with AS/NZS 5601.

Y Piece - Direct: Allows the twin flues to be joined to a single flue for termination. It is recommended that the flue be taken vertically as high as is practicable before joining to the Y Box assembly.

Y Piece - Offset / Extended Offset: Same as “Y Piece - Direct” with the inclusion of one 45° offset or extended offset.

Twin - Direct: Uses two separate flue pipes to the flue termination point.

Twin - Offset / Extended Offset: Same as “Twin - Direct” with the inclusion of one 45° offset or extended offset.

Minimum Flue Heights	Y Piece Direct	Y Piece Offset	Twin - Direct	Twin - Offset	Twin - Extended Offset
	2.4m	3.6m*	2.4m	3.6m*	3.6m*

* Only 1 x 45° bend set can be used on each flue for Offset or Extended Offset flue installations.

Additional bends may be utilised, however this will then require that additional vertical lengths also be included to increase the flue height in accordance with AS/NZS 5601.

Flue Components

- A. AUFLUE150/200**
1220mm twin skin flue pipe -
ø 150mm inner / ø 200mm outer
(approx 1180mm when installed)
- B. AUFLUEYILL18**
1. Y piece collector box (1x) -
2x ø 150mm inner / ø 200mm outer to
1x ø 200mm inner / ø 250mm outer.
 2. 45° twin skin bends (2x) -
ø 150mm inner / ø 200mm outer.
 3. 150mm flue pipe (2x) -
ø 150mm.
 4. 200mm flue pipe over-wraps (2x) -
ø 200mm.
(height approx 615mm when installed)
- C. AUFLUE200/250**
1220mm twin skin flue pipe -
ø 250mm inner / ø 300mm outer
(approx 1180mm when installed)
- D. RFCOWL200/250**
Connection ø 200mm, Outer ø 350mm
- E. AUBENDSET150/200**
2x 45° twin skin bends -
ø 150mm inner / ø 200mm outer
(height approx 322mm when installed)
- F. AUBENDSET200/350**
2x 45° twin skin bends -
ø 200mm inner / ø 250mm outer
(height approx 357mm when installed)
- G. RFCOWL150/200**
Connection ø 150mm, Outer ø 300mm

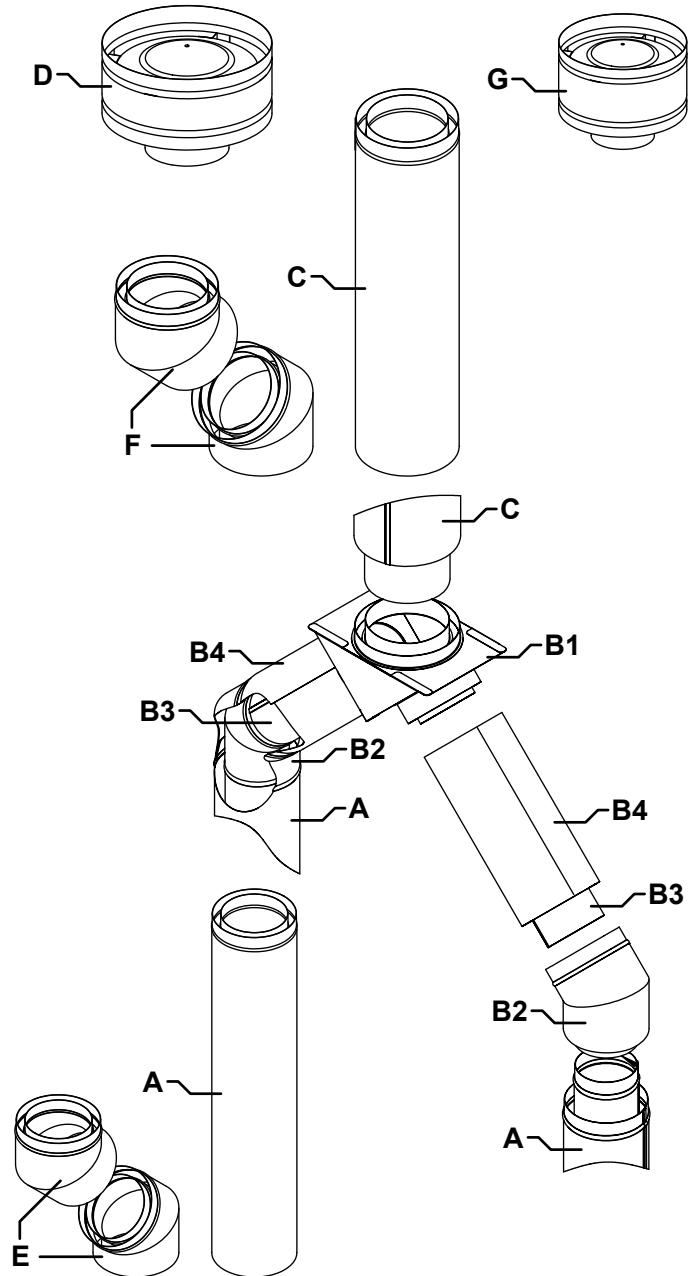

Y Piece Collector Box Assembly

1. Fit the AUFLUE150/200 flue pipes (**A**) onto the engine using rivets and sealant as required.
2. Fit the ø 150mm inner 45° bends (**B2**) but do not fix in place yet.
3. Fit the ø 200mm outer 45° bends (**B2**) and leave loose.
4. Fit the two 150mm ø 460mm lengths of flue pipe (**B3**) to the ø 150mm inner connections of the Y piece collector box (**B1**), then fit and square up with the assembly from above. Then fix all but the ø 200mm outer 45° bends (**B2**) in place.
5. Fit the two 200mm over-wraps (**B4**) over the ø 200mm outer 45° bends (**B2**) and the ø 200mm outer connections of the Y piece collector box (**B1**) and fix all in place.
6. Complete the flue to the termination point using AUFLUE200/250 (**C**) and RFCOWL200/250 (**D**) as required.



The minimum total flue height is 2.4 metres, providing the flue is direct without offsets.

Offsets can be used on flues over 3.6 metres in height.

ENGINE INSTALLATION

Installation Options

The appliance can be installed in 4 different ways. The basic appliance is supplied ready for installation as a fully open appliance where the appliance is open to the front and the glass sides are to the right and back. It is also available as a right hand appliance if required.



All appliances are shown with the open side foremost and glass panels to the back and right hand end. Even with the insulation kits installed, the glass panels remain in place.

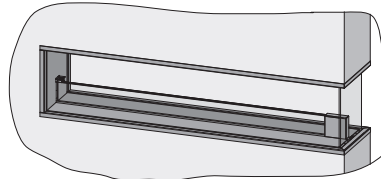

Fully Open

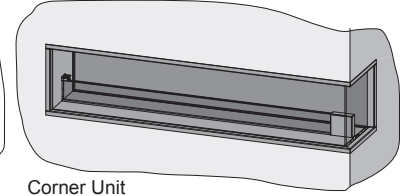

Corner Unit

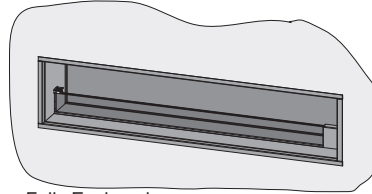

Fully Enclosed

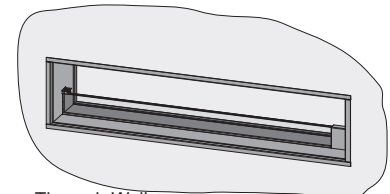

Through Wall

Rear & End Reflector Kit Fitting

Reflector kits are used to convert the appliance for the Corner, Fully Enclosed and Through Wall installation options and require fitting before the installation continues. Unseen trims may need to be cut away to make fitting of the wall-board easier and tidier, the trims to cut will depend on the installation option.



Make sure that you have clearly identified the panels that are to be cut before proceeding. It may be easier to fit the insulation panel prior to making any cuts. Be sure to remove all the protective plastic from any panels that will be covered by the insulation panels

Relieve corner of unseen trim to allow wall lining to fit behind the trim

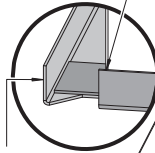

DO NOT CUT THE SEEN TRIM PANELS

Cut here for Through Wall and Fully Enclosed

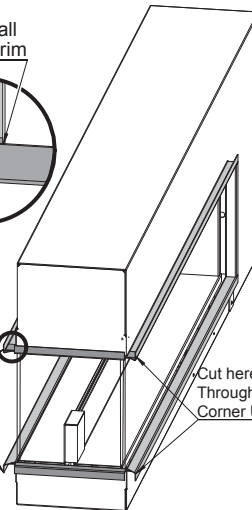

Cut here for Through Wall and Corner Unit

Align faces and edges

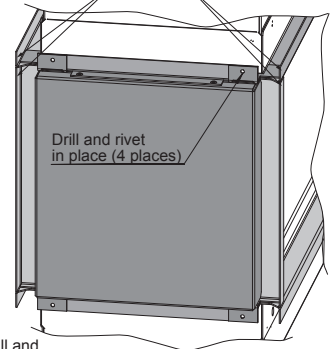

Drill and rivet in place (4 places)

Framing Drawings

The diagrams on the following pages show the framing requirements for each installation type.



The flue and engine must be installed before the wall can be lined. Remember that both gas and electricity are required within the cavity (see, "Gas & Electrical Supplies" on page 10).

The framing must be self supporting and not place any load on the engine.

The flue system must also be supported and not placing load on the engine.

The framing shown is indicative only is not intended to illustrate the construction method. The installation shows one flue option (using the optional Y-Piece) but does not represent a complete system.

The appliance should be installed on a solid platform.

Gas and power supply must enter through the left hand end of the engine when viewed from the open side (the reverse is true for a right handed appliance).

The wall lining above the appliance must be non combustible for a minimum off 300 mm above the top trim.

When engine installation is complete, the fitting of cardboard from the packaging material to the front flanges on both sides of the appliance with some low-tac masking tape will help to protect the appliance from dust, paint, etc. of subsequent construction drawing into the appliance or marking the glass.

Fully Open

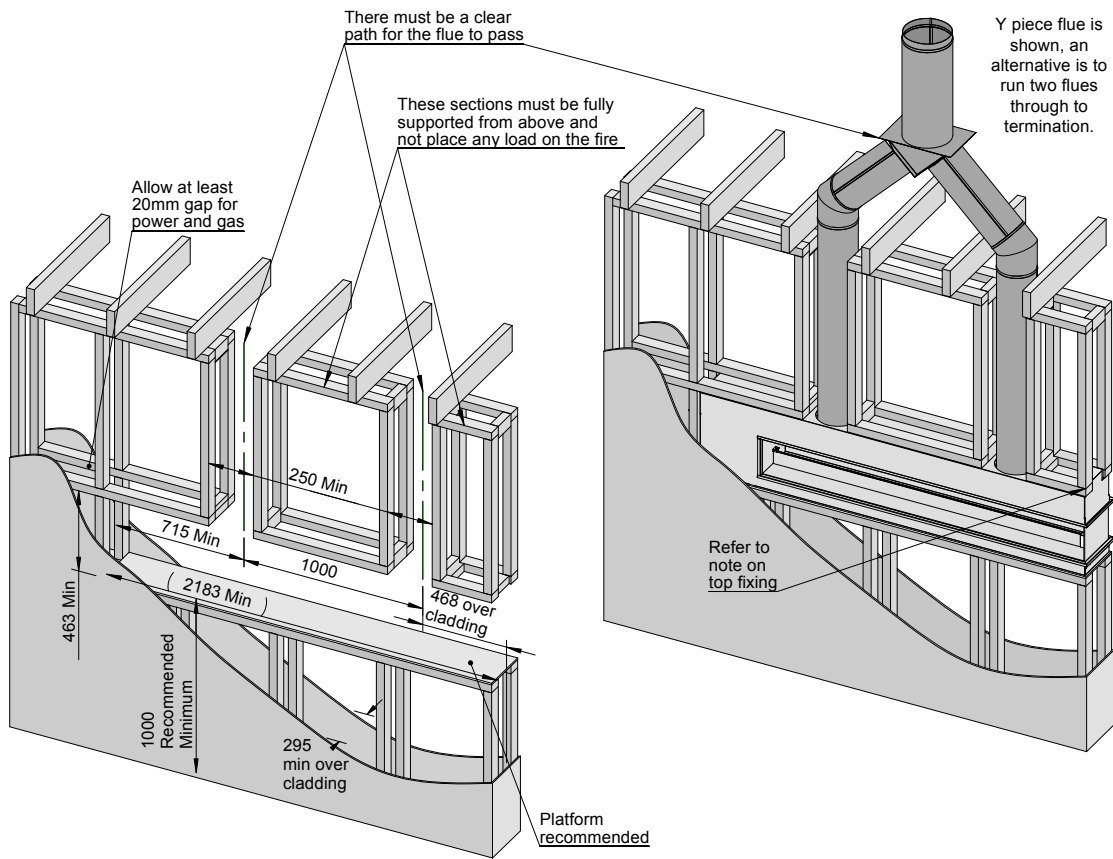

Corner

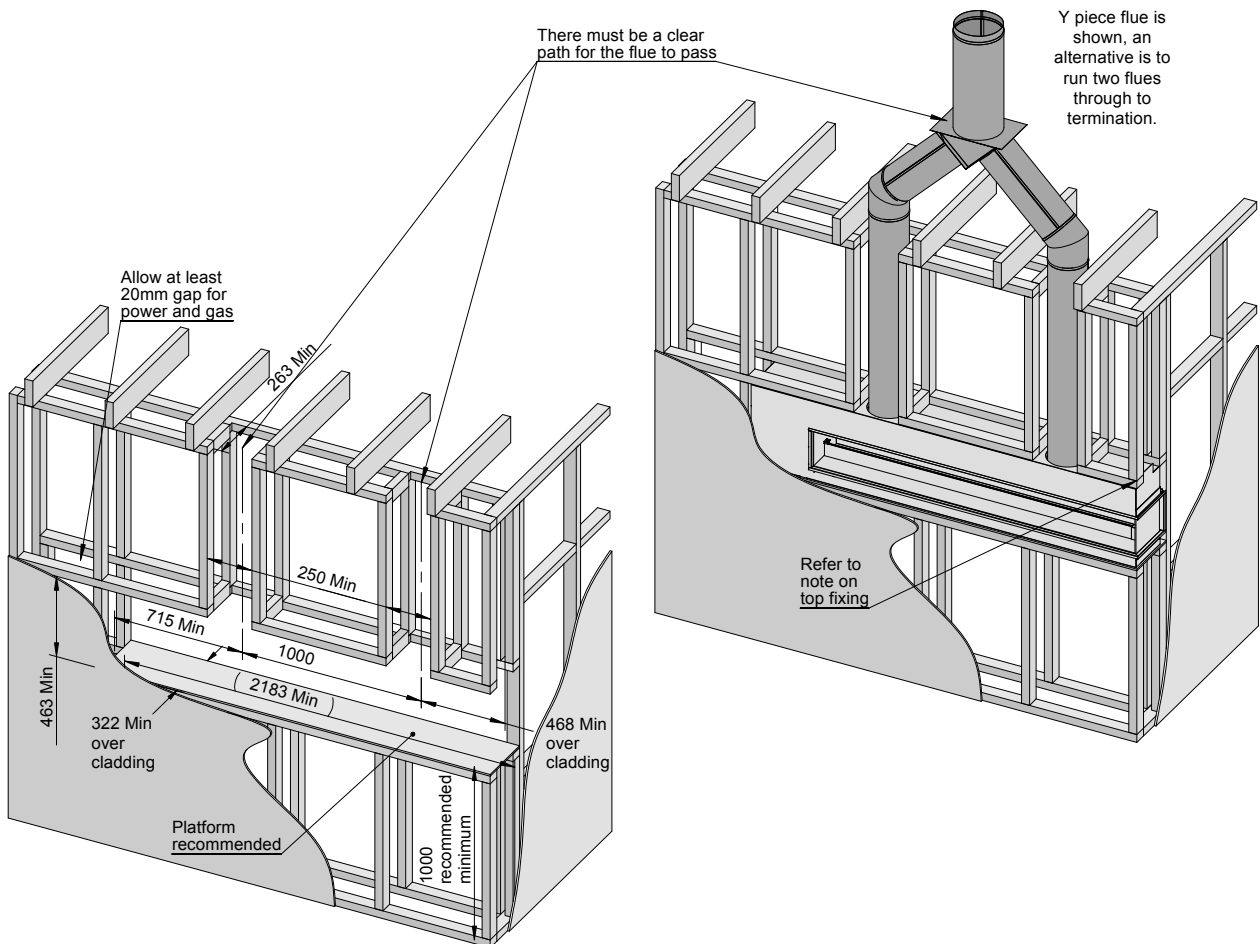

Fully Enclosed

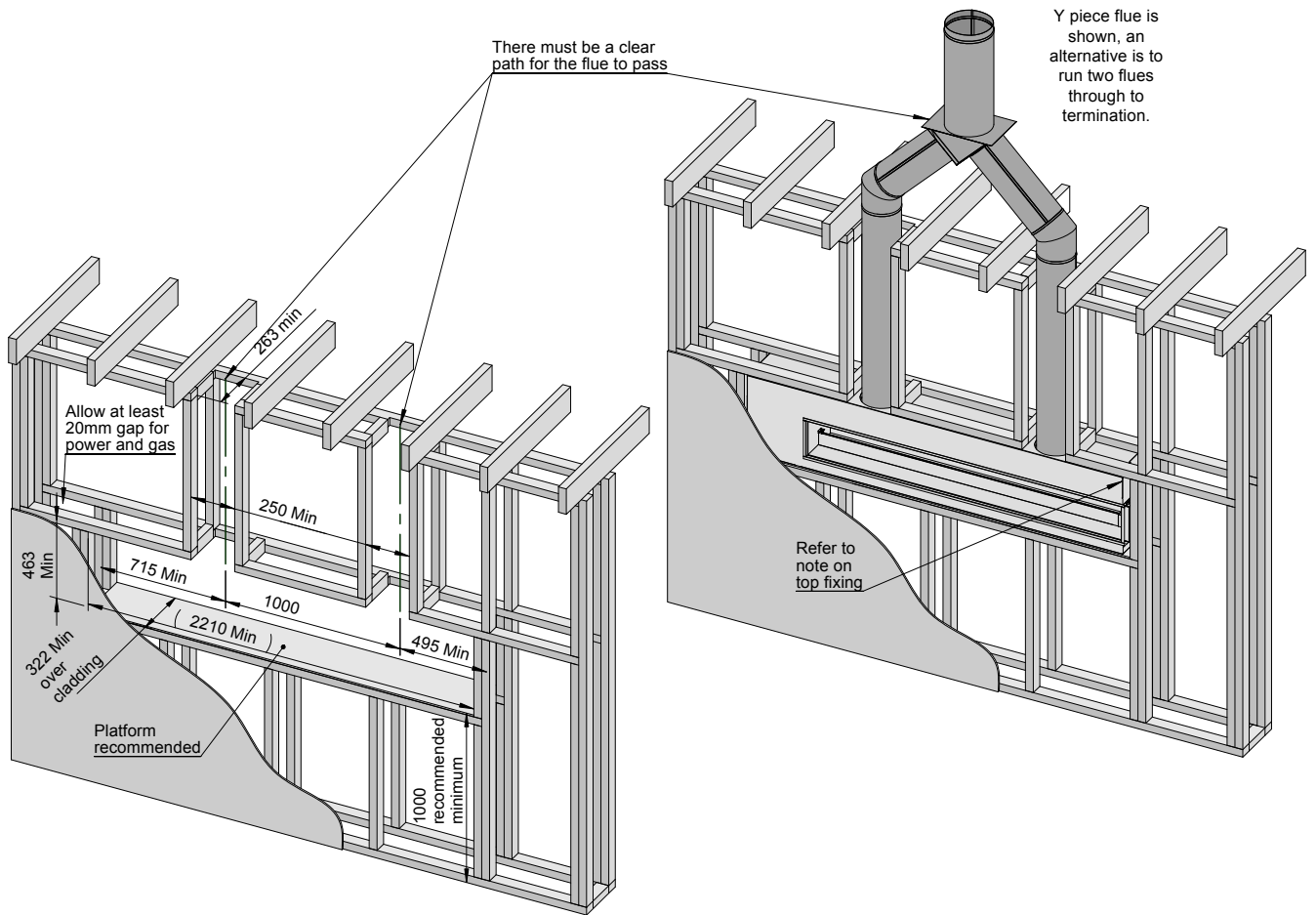

Through Wall

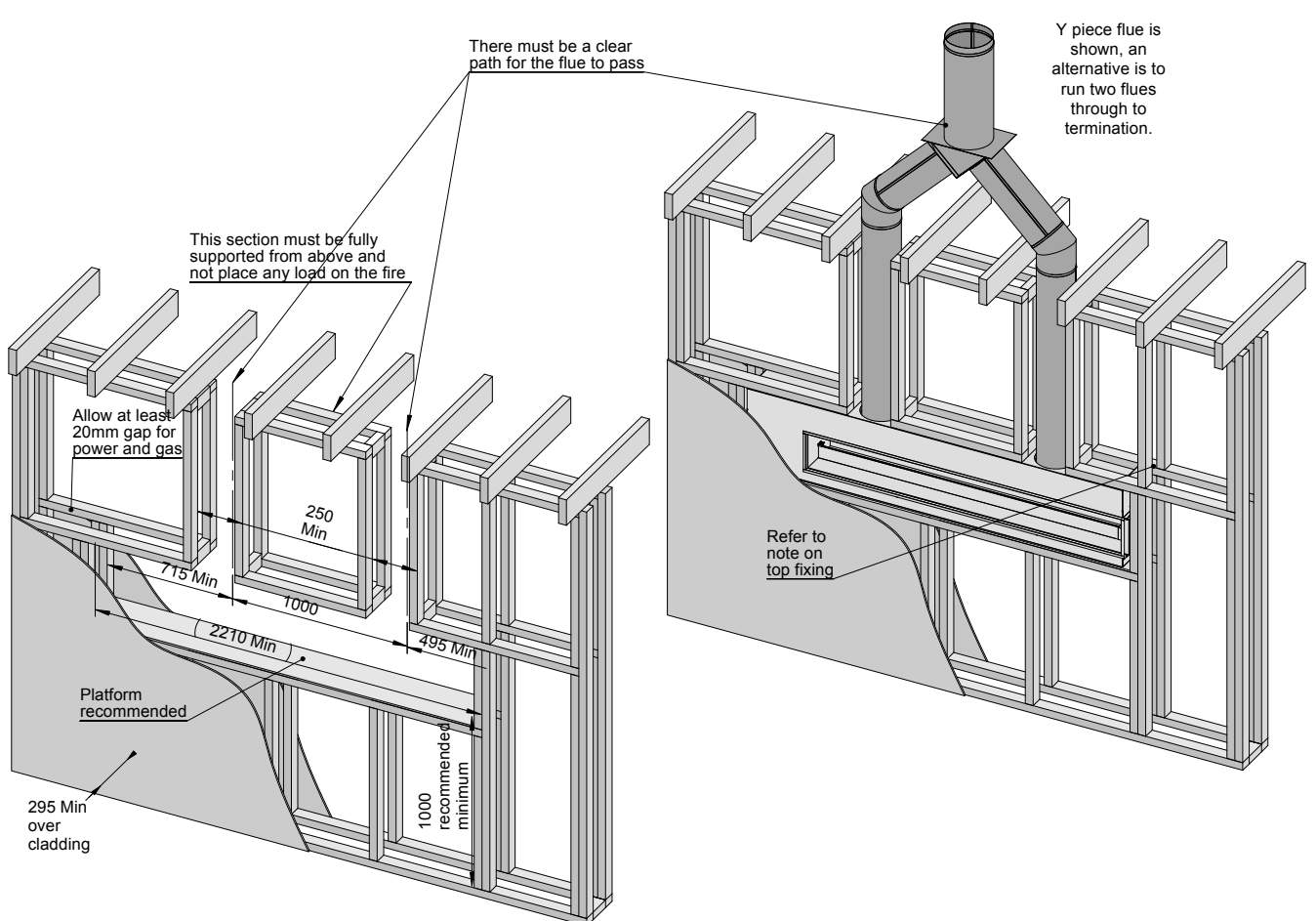

TOP FIXING

In order to keep the top, unsupported end of the engine in line with the framing above, a support plate has been provided for fixing to the completed framing.

In some installations the support plate may not be the most suitable solution. If this is the case then use another seismic type strap to hold the engine fast to the framing. Take care to make sure that the wall cladding will line up with the inside edge of the trim panel.

Shown here is the cut-out requirement for making the support plate most effective.

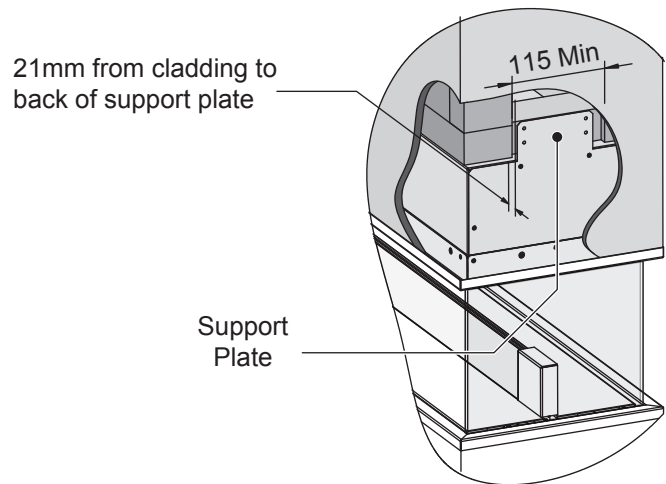

WALL LINING

The wall lining above the top trim must be non-combustible for at least 300mm.

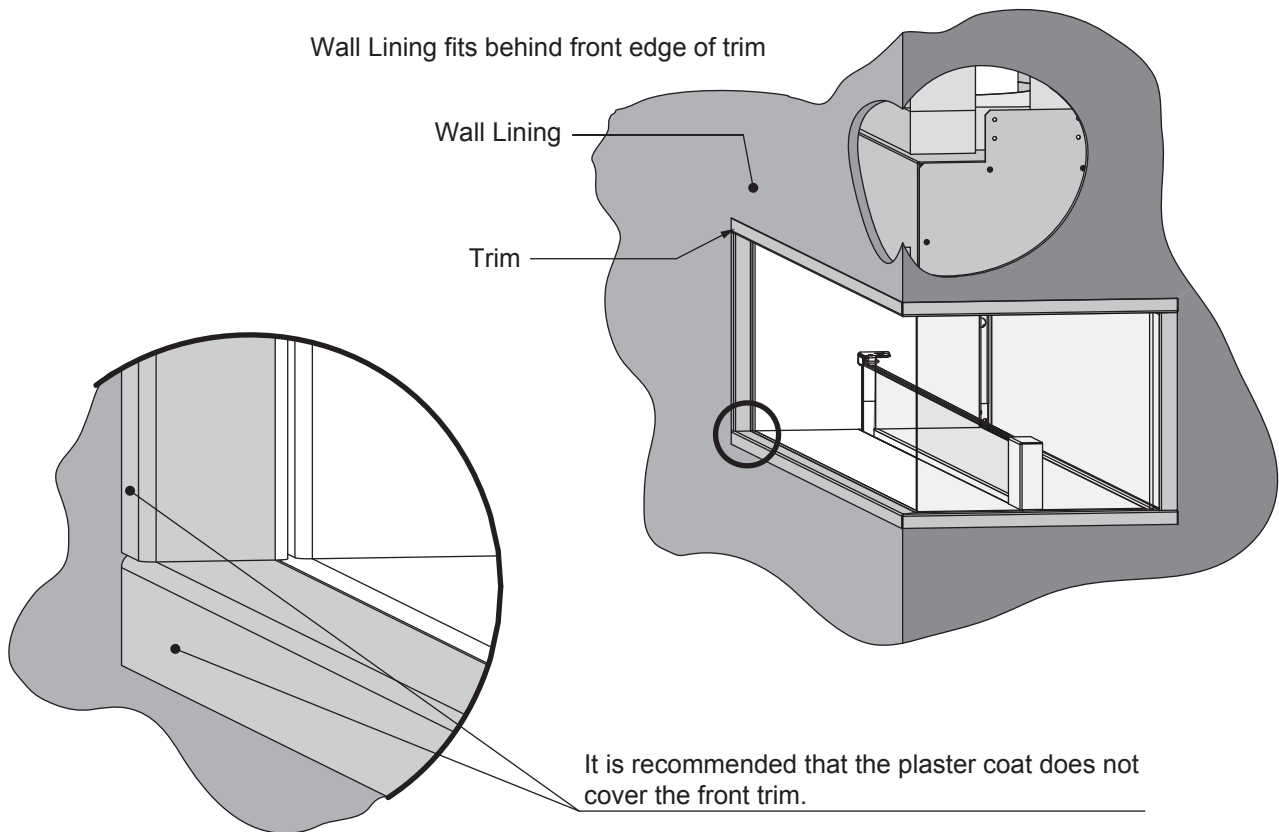

Seismic Restraint: There are 4 holes in the base of the engine to hold the appliance in place. Make sure that the engine is correctly aligned with where the wall lining will finish before fixing the engine in place.

APPLIANCE GAS CONNECTION & COMMISSIONING



ISOLATE THE POWER AND GAS SUPPLIES BEFORE COMMENCING WORK ON THE APPLIANCE.

Once the engine has been installed and fixed to the building the gas and electricity can be connected, however some installers elect to leave this until the decorating has been completed before finalising the installation.



If commissioning is to be carried out after the decorating is completed, then leave the protective plastic coverings in place and cover the front of the engine with cardboard and low-tack tape to prevent plaster dust and debris from entering and damaging the appliance.

Refer to the diagram below for part identification.

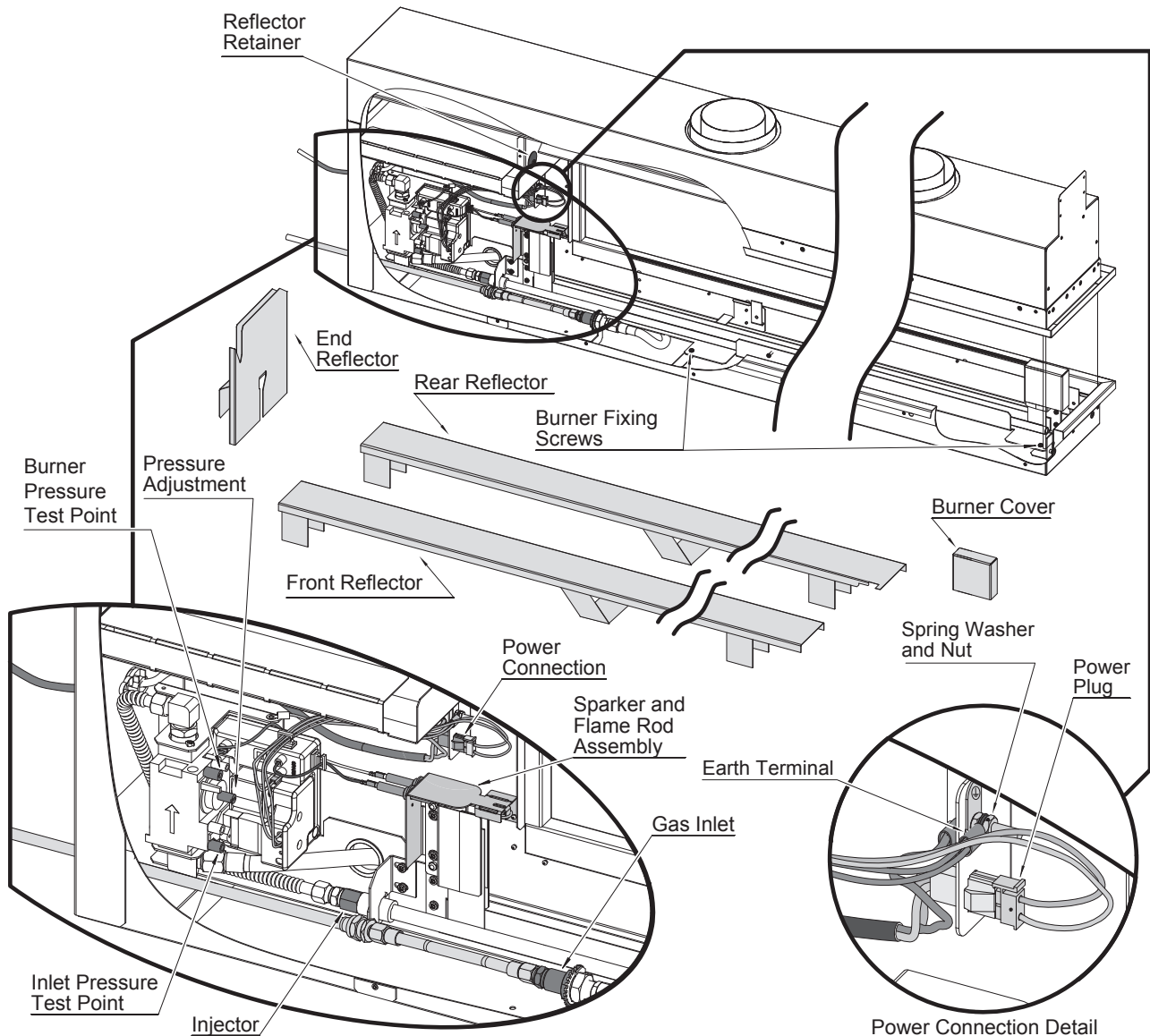

Preparation

1. To gain access to the burner, power, and gas connections, firstly rotate the Reflector Retainer upwards to release the top of the End Reflector and remove this reflector.
2. Remove the Burner Cover by carefully lifting straight up.
3. Slide the Front Reflector towards the gas control so as to be able to gain purchase on both ends of the reflector and remove it.
4. Remove the 2 screws holding the burner in place and slide the burner assembly forward to gain access to the Rear Reflector, slide the Rear Reflector towards the gas control so as to be able to gain purchase on both ends of the reflector and remove it.
5. Push the burner assembly as far back as possible without crushing the gas supply hose or wires etc.

Connecting Gas

1. Use the supplied Gas Connection Kit to connect the consumer piping to the appliance gas inlet.
2. Check for any crimps or kinks in the braided hose. Reconnect the gas supply and check for leaks.
3. Remove all the protective plastic film from both sides of the appliance.

Gas Commissioning



240 VOLTS, RISK OF ELECTRICAL SHOCK!

When performing the commissioning, the appliance electrical power will need to be connected. Wiring inside this appliance may be at 240V potential, exercise CAUTION as there is potential for electric shock from the exposed wiring and circuitry. DO NOT leave the appliance unattended when power is connected and the panels are removed.

Installation and commissioning must be carried out by an authorised person.

DO NOT test for gas escapes with an open flame.



GAS PRESSURES

Refer to the appliance data plate located inside the appliance on a swing tag for correct gas pressure settings.

To check and set burner pressures:

1. With the burner connected and pushed to the back of the engine, using a suitable screw driver loosen the captive Appliance Test Point Pressure (ATPP) screw **A** and fit manometer (an electronic manometer is recommended). Refer images for ATPP location.
2. Remove the brass plug **B** from the regulator adjusting screw.
3. Connect and turn 'ON' the mains supply to the appliance. The spark ignition will start within a few seconds and the burner will ignite. If the burner fails to ignite within about 5 seconds, the spark will stop and the gas will cease to flow. It may take several attempts to get the burner to ignite especially with a new gas installation. Restart the appliance by turning the mains power switch off, waiting a couple of seconds, then switching back on.
4. Adjust the burner pressure with the regulator adjusting screw **C**. Checking the pressures against that of the data plate. Turning clockwise increases the outlet pressure whilst turning anticlockwise decreases the outlet pressure.
5. Once adjusted turn the mains supply to the appliance 'OFF', replace the brass plug **B** and remove the manometer and re-tighten the ATPP screw **A**. Check all connections and test points for leaks using soapy water solutions.

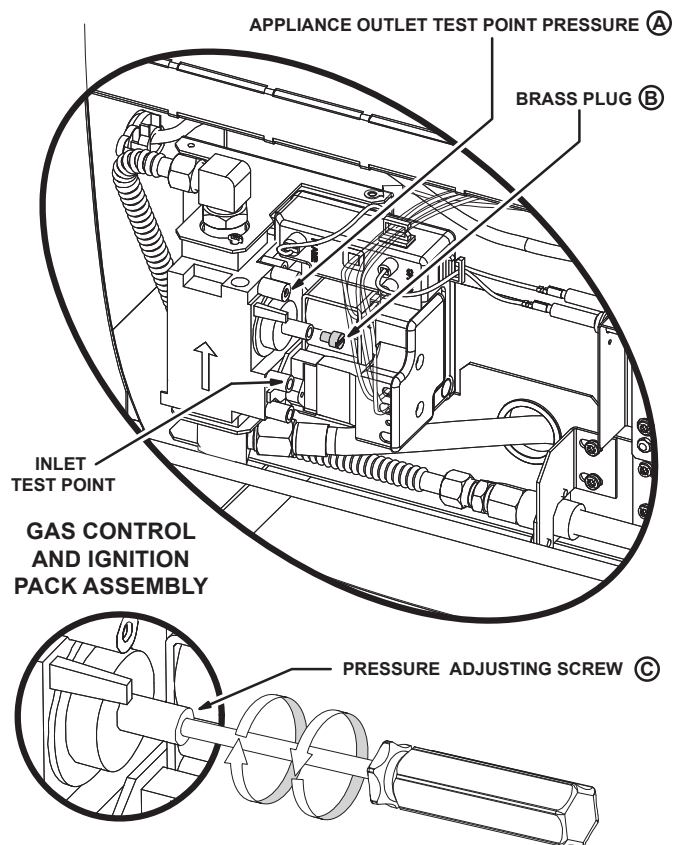

To ensure the correct operation of the valve it is necessary that the brass plug **B** is returned to its original location.

6. Turn the appliance 'ON' and 'OFF' a few times to confirm correct ignition and operation.
7. Check the flame pattern, see "When to call for Service" on page 7.
8. Replace all panels and reflectors previously removed, make sure that the burner is fastened in place and that all protective plastic has been removed. After re-assembly confirm that the appliance is still operational.

FINAL CHECKS

Check that the appliance operates properly making sure that all the supplied parts are used and properly installed.

It is important that the customer is fully aware of how to operate the appliance properly and safely. Advise the customer to fully read the operation sections of this manual to understand how to get the best out of their appliance. Advise the customer of the need for regular servicing in order to maintain the warranty.

Complete the **Commissioning Checklist**.

TROUBLE SHOOTING

Symptom	Possible Cause(s)	Owner Actions	Installer Actions
Appliance does not start (no spark noise)	Mains power disconnected	→	Check mains supply and isolating switch are 'On'
	Gas control locked out	→	Switch 'Off' and 'On' again *
	Faulty spark electrode	Service call	Check HT lead Check Electrode is not touching the bracket
	Power fuse blown	Service call	Replace fuse
Appliance is sparking then stops (no flames)	Air in gas pipe	Service call	Purge gas pipes *
	Gas supply turned off/empty	→	Turn on gas supply or change bottles *
Flame starts but spark keeps going	Faulty flame rod	Service call	Check flame rod lead Check flame rod is not touching the bracket
	Wind blowing on burner	→	Prevent excessive draft on burner
Flame starts but then goes out	Faulty flame rod	Service call	Check flame rod lead Check flame rod is not touching the bracket
	Wind blowing on burner	→	Prevent excessive draft on burner
Appliance goes out	Gas supply 'Off' or empty	→	Check gas supply or change/replace bottles
	Power supply turned off	→	Check power is on
	Wind blowing on burner	→	Prevent excessive draft 'On' burner

* If the appliance fails to ignite after four (4) attempts, turn off the power and gas if possible and arrange for a service call or contact the installer if the unit is newly installed.

→ Owner corrective action is the same as that of an installer, all other corrective actions are for authorised persons only!

COMMISSIONING CHECKLIST

TO BE COMPLETED BY THE INSTALLER

Serial Number _____

Installers Name _____

Installers License No. _____

Installers Contact No. _____

Certificate Of Compliance No. _____

Installation Date _____ / _____ / _____

	NO	YES
1. Is the appliance positioned in a suitable location with regards to clearances?	<input type="checkbox"/>	<input type="checkbox"/>
2. Is the unit fixed in location?	<input type="checkbox"/>	<input type="checkbox"/>
3. Have all gas connections been checked for leaks using a soapy water solution?	<input type="checkbox"/>	<input type="checkbox"/>
4. Have you instructed the owner of the correct operation of this appliance before leaving?	<input type="checkbox"/>	<input type="checkbox"/>
5. Have you left the operating instructions with the owner?	<input type="checkbox"/>	<input type="checkbox"/>
6. Have you removed all PVC plastic coating material?	<input type="checkbox"/>	<input type="checkbox"/>



Ensure all PVC plastic coating material is removed before operating the unit.

If you have answered NO to any of the above questions you MUST NOT allow the appliance to be operated until the item has been rectified.

WIRING DIAGRAMS

Appliance Wiring Diagram

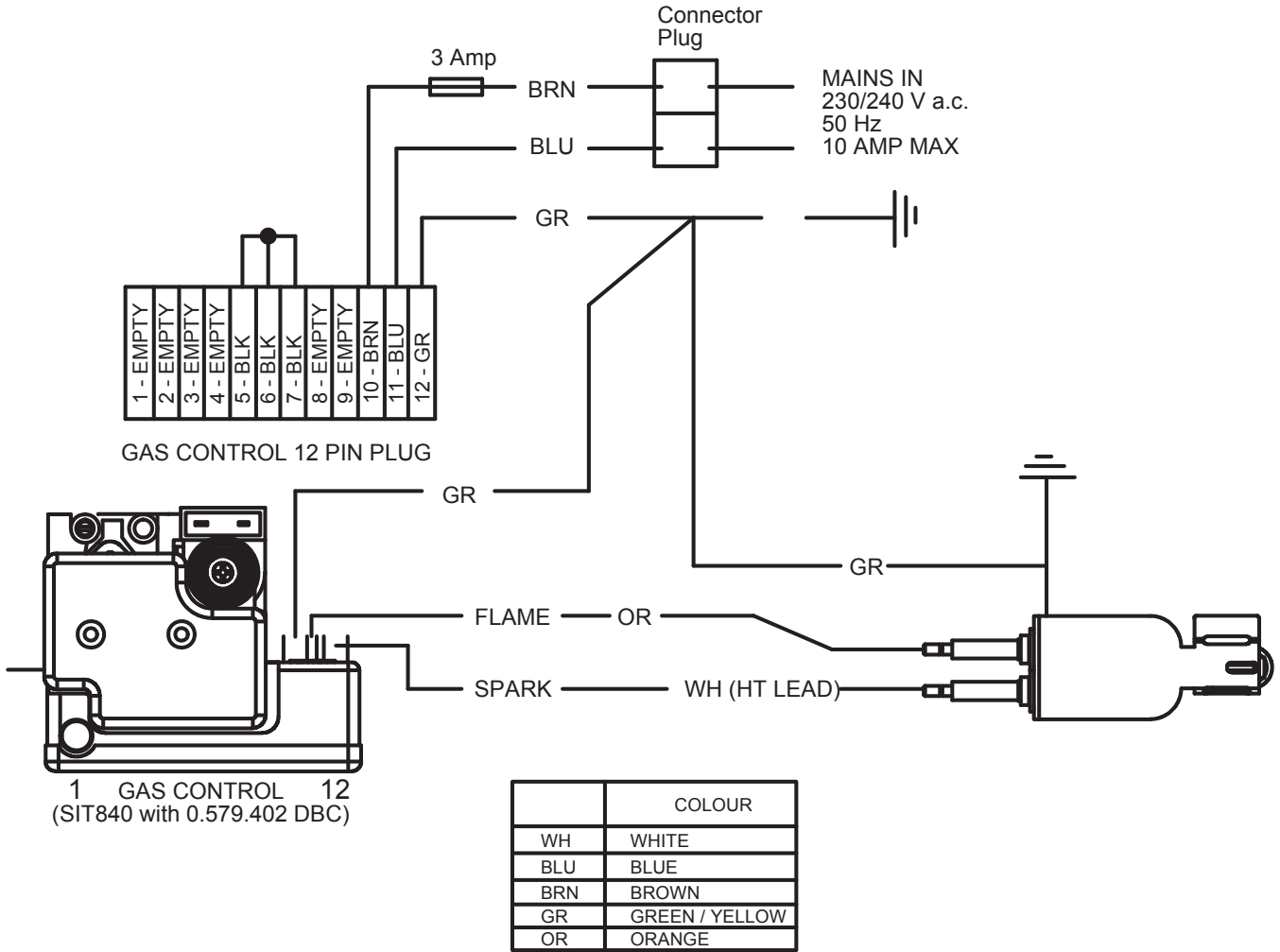

Latched Relay Wiring Diagram

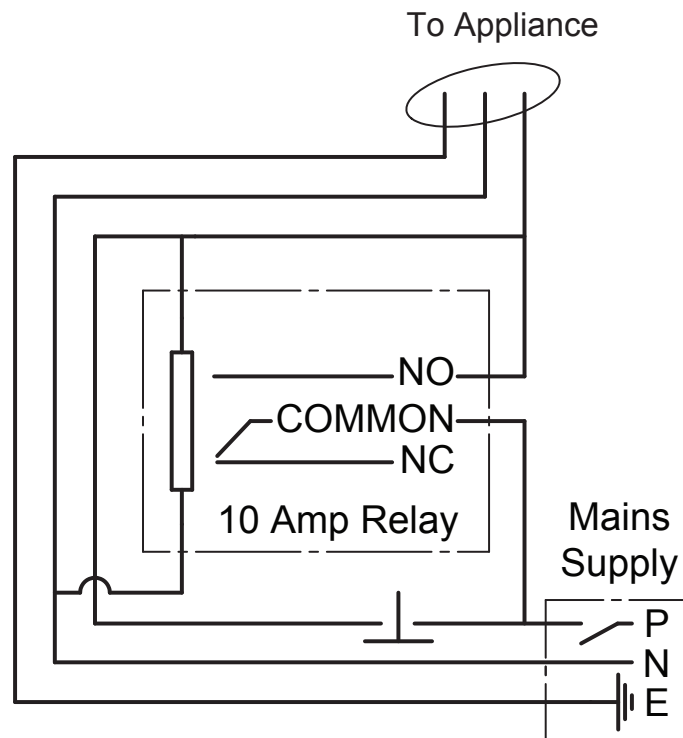

Rinnai

Rinnai Australia Pty. Ltd. ABN 74 005 138 769

Head Office

10-11 Walker Street,
Braeside, Victoria 3195
P.O. Box 460
Tel: (03) 9271 6625
Fax: (03) 9271 6622

Rinnai has a Service and Spare Parts network with personnel who are fully trained and equipped to give the best service on your Rinnai appliance. If your appliance requires service, please call our National Help Line. Rinnai recommends that this appliance be serviced every 2 years.

Internet: www.rinnai.com.au E-mail: enquiry@rinnai.com.au

National Help Line

Tel: 1300 555 545* Fax: 1300 555 655*

Spare Parts & Technical Info

Tel: 1300 366 388* Fax: 1300 300 141*

**Cost of a local call higher from mobile or public phones.*

