



ANSI/TIA-526-14-B-2010  
APPROVED: AUGUST 27, 2010

# TIA STANDARD

## Optical Power Loss Measurements of Installed Multimode Fiber Cable Plant; IEC 61280-4-1 edition 2, Fibre-Optic Communications Subsystem Test Procedure- Part 4-1: Installed cable plant- Multimode attenuation measurement

TIA-526-14-B

October 2010

TELECOMMUNICATIONS  
INDUSTRY ASSOCIATION

[tiaonline.org](http://tiaonline.org)

## NOTICE

TIA Engineering Standards and Publications are designed to serve the public interest through eliminating misunderstandings between manufacturers and purchasers, facilitating interchangeability and improvement of products, and assisting the purchaser in selecting and obtaining with minimum delay the proper product for their particular need. The existence of such Standards and Publications shall not in any respect preclude any member or non-member of TIA from manufacturing or selling products not conforming to such Standards and Publications. Neither shall the existence of such Standards and Publications preclude their voluntary use by Non-TIA members, either domestically or internationally.

Standards and Publications are adopted by TIA in accordance with the American National Standards Institute (ANSI) patent policy. By such action, TIA does not assume any liability to any patent owner, nor does it assume any obligation whatever to parties adopting the Standard or Publication.

This Standard does not purport to address all safety problems associated with its use or all applicable regulatory requirements. It is the responsibility of the user of this Standard to establish appropriate safety and health practices and to determine the applicability of regulatory limitations before its use.

(From Standards Project No.3-2981-RV2, formulated under the cognizance of the TIA TR-42 Telecommunications Cabling Systems, TR-42.11 Subcommittee on Optical Systems).

Published by

©TELECOMMUNICATIONS INDUSTRY ASSOCIATION  
Standards and Technology Department  
2500 Wilson Boulevard  
Arlington, VA 22201 U.S.A.

**PRICE: Please refer to current Catalog of  
TIA TELECOMMUNICATIONS INDUSTRY ASSOCIATION STANDARDS  
AND ENGINEERING PUBLICATIONS  
or call IHS, USA and Canada  
(1-877-413-5187) International (303-397-2896)  
or search online at <http://www.tiaonline.org/standards/catalog/>**

All rights reserved  
Printed in U.S.A.

# NOTICE OF COPYRIGHT

**This document is copyrighted by the TIA.**

**Reproduction of these documents either in hard copy or soft copy (including posting on the web) is prohibited without copyright permission.** For copyright permission to reproduce portions of this document, please contact TIA Standards Department or go to the TIA website ([www.tiaonline.org](http://www.tiaonline.org)) for details on how to request permission. Details are located at:

<http://www.tiaonline.org/standards/catalog/info.cfm#copyright>

OR

Telecommunications Industry Association  
Standards & Technology Department  
2500 Wilson Boulevard, Suite 300  
Arlington, VA 22201 USA  
+1(703)907-7700

Organizations may obtain permission to reproduce a limited number of copies by entering into a license agreement. For information, contact:

IHS  
15 Inverness Way East  
Englewood, CO 80112-5704 or call  
U.S.A. and Canada (1-800-525-7052)  
International (303-790-0600)



## **NOTICE OF DISCLAIMER AND LIMITATION OF LIABILITY**

The document to which this Notice is affixed (the “Document”) has been prepared by one or more Engineering Committees or Formulating Groups of the Telecommunications Industry Association (“TIA”). TIA is not the author of the Document contents, but publishes and claims copyright to the Document pursuant to licenses and permission granted by the authors of the contents.

TIA Engineering Committees and Formulating Groups are expected to conduct their affairs in accordance with the TIA Engineering Manual (“Manual”), the current and predecessor versions of which are available at <http://www.tiaonline.org/standards/procedures/manuals/> TIA’s function is to administer the process, but not the content, of document preparation in accordance with the Manual and, when appropriate, the policies and procedures of the American National Standards Institute (“ANSI”). TIA does not evaluate, test, verify or investigate the information, accuracy, soundness, or credibility of the contents of the Document. In publishing the Document, TIA disclaims any undertaking to perform any duty owed to or for anyone.

If the Document is identified or marked as a project number (PN) document, or as a standards proposal (SP) document, persons or parties reading or in any way interested in the Document are cautioned that: (a) the Document is a proposal; (b) there is no assurance that the Document will be approved by any Committee of TIA or any other body in its present or any other form; (c) the Document may be amended, modified or changed in the standards development or any editing process.

The use or practice of contents of this Document may involve the use of intellectual property rights (“IPR”), including pending or issued patents, or copyrights, owned by one or more parties. TIA makes no search or investigation for IPR. When IPR consisting of patents and published pending patent applications are claimed and called to TIA’s attention, a statement from the holder thereof is requested, all in accordance with the Manual. TIA takes no position with reference to, and disclaims any obligation to investigate or inquire into, the scope or validity of any claims of IPR. TIA will neither be a party to discussions of any licensing terms or conditions, which are instead left to the parties involved, nor will TIA opine or judge whether proposed licensing terms or conditions are reasonable or non-discriminatory. TIA does not warrant or represent that procedures or practices suggested or provided in the Manual have been complied with as respects the Document or its contents.

If the Document contains one or more Normative References to a document published by another organization (“other SSO”) engaged in the formulation, development or publication of standards (whether designated as a standard, specification, recommendation or otherwise), whether such reference consists of mandatory, alternate or optional elements (as defined in the TIA Engineering Manual, 4<sup>th</sup> edition) then (i) TIA disclaims any duty or obligation to search or investigate the records of any other SSO for IPR or letters of assurance relating to any such Normative Reference; (ii) TIA’s policy of encouragement of voluntary disclosure (see Engineering Manual Section 6.5.1) of Essential Patent(s) and published pending patent applications shall apply; and (iii) Information as to claims of IPR in the records or publications of the other SSO shall not constitute identification to TIA of a claim of Essential Patent(s) or published pending patent applications.

TIA does not enforce or monitor compliance with the contents of the Document. TIA does not certify, inspect, test or otherwise investigate products, designs or services or any claims of compliance with the contents of the Document.

ALL WARRANTIES, EXPRESS OR IMPLIED, ARE DISCLAIMED, INCLUDING WITHOUT LIMITATION, ANY AND ALL WARRANTIES CONCERNING THE ACCURACY OF THE CONTENTS, ITS FITNESS OR APPROPRIATENESS FOR A PARTICULAR PURPOSE OR USE, ITS MERCHANTABILITY AND ITS NONINFRINGEMENT OF ANY THIRD PARTY’S INTELLECTUAL PROPERTY RIGHTS. TIA EXPRESSLY DISCLAIMS ANY AND ALL RESPONSIBILITIES FOR THE ACCURACY OF THE CONTENTS AND MAKES NO REPRESENTATIONS OR WARRANTIES REGARDING THE CONTENT’S COMPLIANCE WITH ANY APPLICABLE STATUTE, RULE OR REGULATION, OR THE SAFETY OR HEALTH EFFECTS OF THE CONTENTS OR ANY PRODUCT OR SERVICE REFERRED TO IN THE DOCUMENT OR PRODUCED OR RENDERED TO COMPLY WITH THE CONTENTS.

TIA SHALL NOT BE LIABLE FOR ANY AND ALL DAMAGES, DIRECT OR INDIRECT, ARISING FROM OR RELATING TO ANY USE OF THE CONTENTS CONTAINED HEREIN, INCLUDING WITHOUT LIMITATION ANY AND ALL INDIRECT, SPECIAL, INCIDENTAL OR CONSEQUENTIAL DAMAGES (INCLUDING DAMAGES FOR LOSS OF BUSINESS, LOSS OF PROFITS, LITIGATION, OR THE LIKE), WHETHER BASED UPON BREACH OF CONTRACT, BREACH OF WARRANTY, TORT (INCLUDING NEGLIGENCE), PRODUCT LIABILITY OR OTHERWISE, EVEN IF ADVISED OF THE POSSIBILITY OF SUCH DAMAGES. THE FOREGOING NEGATION OF DAMAGES IS A FUNDAMENTAL ELEMENT OF THE USE OF THE CONTENTS HEREOF, AND THESE CONTENTS WOULD NOT BE PUBLISHED BY TIA WITHOUT SUCH LIMITATIONS.

## ANSI/TIA Foreword

International Standard IEC 61280-4-1 Ed. 2.0 has been prepared by subcommittee 86C: Fibre optic systems and active devices, of IEC technical committee 86: Fibre optics. This document, OFSTP-14-B is an adoption of IEC 61280-4-1 and supersedes ANSI/TIA/EIA-526-14-A, Optical Power Loss Measurements of Installed Multimode Fiber Cable Plant. This foreword includes clarification on major changes between earlier versions of the TIA document and this version including the nomenclature for the three reference methods and text to describe additional encircled flux launch conditions uncertainty not previously considered in the IEC document.

### Reference methods nomenclature

The different ways in which reference measurements can be made of the power input to the cabling under test are explicitly referred to in the IEC document by the number of test cords that are used in the reference configuration. In the TIA document these were often referenced as configuration A, B or C. A cross reference of these test methods is shown in the table below.

IEC 61280-4-1 Ed. 2.0		OFSTP-14-A
Name	Location	Name
One-cord reference method	Annex A	Method B
Three-cord reference method	Annex B	Method C
Two-cord reference method	Annex C	Method A

### OTDR testing

OTDR testing was not in the original OFSTP-14-A. The use of the OTDR for measuring attenuation is described in Annex D for total attenuation with additional guidance in Annex G including measuring individual component losses.

### Inspecting and cleaning connectors

The IEC document highlights the importance of, and gives guidance on, good measurement practices including inspection and cleaning of connector end faces.

### Test cord insertion loss verification

Annex H describes procedures for checking the insertion loss of test cords that should be performed before undertaking cable plant measurements, as poorly performing test cords invalidate measurements made with them. The procedures are delineated by the reference measurement method and by the type of connector system.

### Reference grade connectors

This document recommends the use of 'reference grade connections' on test cords to reduce measurement uncertainty. This means that there is now a difference between the test result acceptance criteria and the expected link or channel insertion loss in its final configuration. The insertion loss acceptance criteria should be tightened up accordingly.

### Encircled Flux

The requirement for the modal launch conditions for the sources used to measure multimode fibers is changed from one based on coupled power ratio (CPR) and mandrel requirements to one based on measurements of the near field at the output of the launching test cord. The launch condition must now meet the requirements of the specified 'encircled flux template'. Compliance provides significant improvement in measurement repeatability. Note that the Encircled Flux template example of Figure E.1 unintentionally shows incomplete Target and OFL lines. The red Target line should run continuously thru the center of the shaded Template region, and the blue OFL line should be continuous thru the region from 11 to 15  $\mu\text{m}$  radius.

### Encircled flux uncertainty

For field test equipment using a single optical port that launches two wavelengths, a test cord that is conditioned by a mandrel may not allow an alignment on the target for both wavelengths simultaneously. Should this be the case, the use of the same mandrel for both wavelengths will reduce the margin for compliance within the templates and add uncertainty.

Due to the effect of variations in source wavelength, fiber core size and numerical aperture, mandrel tolerances, temperature changes, other physical variations, and the measurement equipment itself, launch conditions at the time of factory calibration will not be identical in the field should any variable change. The use of attenuation artifacts described in IEC 61280-4-1 can help ensure that the equipment produces a launch condition that performs acceptably.

Although this document is not intended to grant compliance to equipment that predates its publication, it may be possible to bring such equipment into compliance with the use of an external mode conditioner designed for this purpose. Unless the equipment, its launch cords, and the external mode conditioner are verified to produce the intended launch conditions, this approach will be an additional source of uncertainty, but that uncertainty may be less than without the use of the external mode conditioner.

#### Alignment of encircled flux targets to eliminate wavelength bias

Efforts were taken to harmonize the expected component losses at 850 nm and 1 300 nm wavelengths for a given fiber core diameter. This was accomplished by adjustment of the 850 nm and 1 300 EF targets to produce comparable extrinsic component losses. An example of matching the attenuation characteristics at the two wavelengths is illustrated in Figure Foreword1. This elimination of bias provides an opportunity to ensure dual wavelength compliance of a passive component or a short cable plant link using a single source.

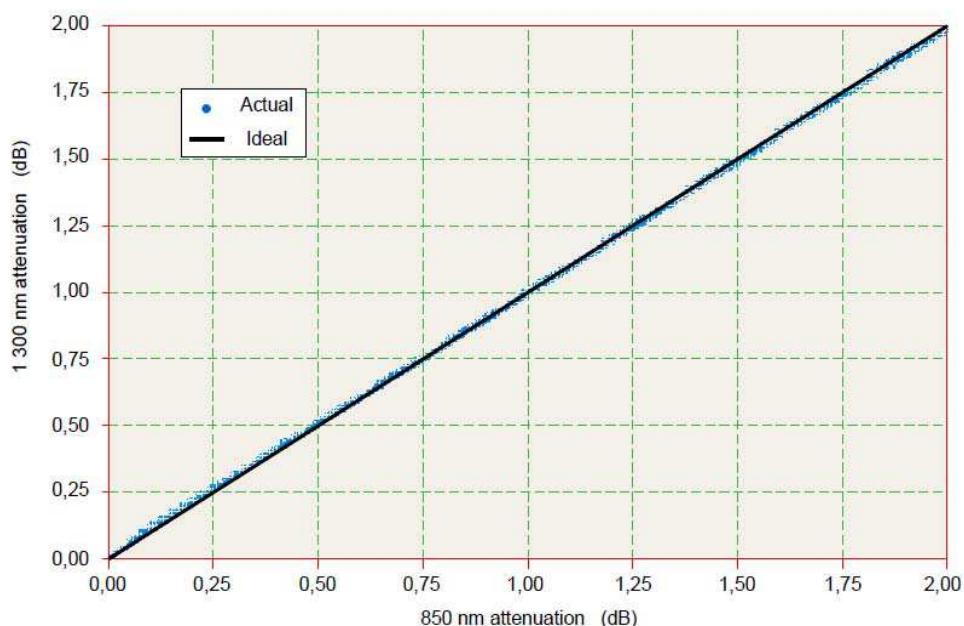

**Figure Foreword1 – Calculated Wavelength Comparison**

#### Other references

The following references document the foundational work underlying the development of the Encircled Flux launch condition specifications and can be obtained at the following internet location:

<http://ftp.tiaonline.org/TR-42/TR-42.11/Public/TSB-178ReferenceRepository>

- 1) T. Hanson, "Considerations on multimode link loss," December 13, 2005
- 2) T. Hanson, "Considerations regarding the target RPD, coupled power, and steady state," July 13, 2006
- 3) R. Conte, "Mode Scattering and Steady State Distributions," August 18, 2006
- 4) Robert Conte, "A Template Based Approach to Source Qualification" , August 18, 2006
- 5) Thomas Hanson and James Luther, "Multimode source boundary experiment," October, 2006
- 6) Robert Conte, "CPR, MPD, and EF," December 5, 2006



## CONTENTS

FOREWORD .....	5
1 Scope .....	7
2 Normative references.....	7
3 Terms, definitions, graphical symbols and acronyms .....	8
3.1 Terms and definitions.....	8
3.2 Graphical symbols .....	9
3.3 Acronyms .....	11
4 Measurement methods.....	11
4.1 General.....	11
4.2 Cabling configurations and applicable test methods.....	12
4.3 Overview of uncertainties .....	12
4.3.1 General.....	12
4.3.2 Test cords.....	13
4.3.3 Launch conditions at the connection to the cabling under test.....	13
4.3.4 Optical source.....	13
4.3.5 Output power reference .....	13
4.3.6 Received power reference .....	14
5 Apparatus .....	14
5.1 General.....	14
5.2 Light source .....	14
5.2.1 Stability .....	14
5.2.2 Spectral characteristics.....	14
5.2.3 Launch cord .....	14
5.3 Receive or tail cord .....	15
5.4 Substitution/dummy cord .....	15
5.5 Power meter – LSPM methods only .....	15
5.6 OTDR apparatus.....	15
5.7 Connector end-face cleaning and inspection equipment.....	16
5.8 Adapters .....	16
6 Procedures.....	16
6.1 General.....	16
6.2 Common procedures .....	17
6.2.1 Care of the test cords .....	17
6.2.2 Make reference measurements (LSPM methods only) .....	17
6.2.3 Inspect and clean the ends of the fibres in the cabling.....	17
6.2.4 Make the measurements.....	17
6.2.5 Make the calculations .....	17
6.3 Calibration.....	17
6.4 Safety .....	17
7 Calculations .....	17
8 Documentation .....	18
8.1 Information for each test .....	18
8.2 Information to be available .....	18
Annex A (normative) One-cord reference method .....	19
Annex B (normative) Three-cord reference method.....	21

Annex C (normative) Two-cord reference method .....	23
Annex D (normative) Optical time domain reflectometer .....	26
Annex E (normative) Requirements for the source characteristics for multimode measurement .....	32
Annex F (informative) Measurement uncertainty examples .....	35
Annex G (informative) OTDR configuration information .....	44
Annex H (informative) Test cord insertion loss verification .....	53
Bibliography .....	61
Figure 1a – Socket and plug assembly .....	10
Figure 1b – Connector set (plug, adapter, plug) .....	10
Figure 1c – Light source .....	10
Figure 1d – Power meter .....	10
Figure 1 – Connector symbols .....	10
Figure 2 – Symbol for cabling under test .....	10
Figure 3 – OTDR schematic .....	16
Figure A.1 – Reference measurement .....	20
Figure A.2 – Test measurement .....	20
Figure B.1 – Reference measurement .....	22
Figure B.2 – Test measurement .....	22
Figure C.1 – Reference measurement .....	24
Figure C.2 – Test measurement .....	24
Figure C.3 – Test measurement for plug-socket style connectors .....	24
Figure D.1 – Test measurement for Method D .....	27
Figure D.2 – Location of the cabling under test ports .....	28
Figure D.3 – Graphic construction of $F_1$ and $F_2$ .....	29
Figure D.4 – Graphic construction of $F_1$ , $F_{11}$ , $F_{12}$ and $F_2$ .....	30
Figure E.1 – Encircled flux template example .....	33
Figure F.1 – Initial power measurement .....	37
Figure F.2 – Verification of reference grade connection .....	38
Figure F.3 – Two offset splices .....	38
Figure F.4 – Five offset splices .....	38
Figure F.5 – EF centred .....	40
Figure F.6 – EF underfilling .....	40
Figure F.7 – EF overfilling .....	41
Figure F.8 – L1 loss with mandrel .....	41
Figure F.9 – L1 loss with mandrel and mode conditioner .....	42
Figure F.10 – L2 loss (adjusted) with mandrel .....	42
Figure F.11 – L2 loss (adjusted) with mandrel and mode conditioning .....	42
Figure F.12 – L3 loss (adjusted) with mandrel .....	43
Figure F.13 – L3 loss (adjusted) with mandrel and mode conditioning .....	43
Figure G.1 – Splice and macro bend attenuation measurement .....	47
Figure G.2 – Attenuation measurement with high reflection connectors .....	48

Figure G.3 – Attenuation measurement of a short length cabling .....49

Figure G.4 – OTDR trace with ghost ..... 50

Figure G.5 – Cursors positioning ..... 51

Figure H.1 – Obtaining reference power level  $P_0$  ..... 54

Figure H.2 – Obtaining power level  $P_1$  ..... 55

Figure H.3 – Obtaining reference power level  $P_0$  ..... 56

Figure H.4 – Obtaining power level  $P_1$  ..... 56

Figure H.5 – Obtaining reference power level  $P_0$  ..... 57

Figure H.6 – Obtaining power level ..... 57

Figure H.7 – Obtaining reference power level  $P_0$  ..... 58

Figure H.8 – Obtaining power level  $P_1$  ..... 58

Figure H.9 – Obtaining power level  $P_5$  ..... 58

Figure H.10 – Obtaining reference power level  $P_0$  ..... 59

Figure H.11 – Obtaining power level  $P_1$ ..... 59

Table 1 – Cabling configurations ..... 12

Table 2 – Test methods and configurations ..... 12

Table 3 – Spectral requirements ..... 14

Table E.1 – Threshold tolerance ..... 33

Table E.2 – EF requirements for 50  $\mu\text{m}$  core fibre cabling at 850 nm ..... 34

Table E.3 – EF requirements for 50  $\mu\text{m}$  core fibre cabling at 1 300 nm ..... 34

Table E.4 – EF requirements for 62,5  $\mu\text{m}$  core fibre cabling at 850 nm ..... 34

Table E.5 – EF requirements for 62,5  $\mu\text{m}$  core fibre cabling at 1 300 nm ..... 34

Table F.1 – Expected loss for examples (note 1) ..... 35

Table G.1 – Default effective group index of refraction values ..... 46

## INTERNATIONAL ELECTROTECHNICAL COMMISSION

**FIBRE-OPTIC COMMUNICATION SUBSYSTEM  
TEST PROCEDURES –****Part 4-1: Installed cable plant –  
Multimode attenuation measurement**

## FOREWORD

- 1) The International Electrotechnical Commission (IEC) is a worldwide organization for standardization comprising all national electrotechnical committees (IEC National Committees). The object of IEC is to promote international co-operation on all questions concerning standardization in the electrical and electronic fields. To this end and in addition to other activities, IEC publishes International Standards, Technical Specifications, Technical Reports, Publicly Available Specifications (PAS) and Guides (hereafter referred to as "IEC Publication(s)"). Their preparation is entrusted to technical committees; any IEC National Committee interested in the subject dealt with may participate in this preparatory work. International, governmental and non-governmental organizations liaising with the IEC also participate in this preparation. IEC collaborates closely with the International Organization for Standardization (ISO) in accordance with conditions determined by agreement between the two organizations.
- 2) The formal decisions or agreements of IEC on technical matters express, as nearly as possible, an international consensus of opinion on the relevant subjects since each technical committee has representation from all interested IEC National Committees.
- 3) IEC Publications have the form of recommendations for international use and are accepted by IEC National Committees in that sense. While all reasonable efforts are made to ensure that the technical content of IEC Publications is accurate, IEC cannot be held responsible for the way in which they are used or for any misinterpretation by any end user.
- 4) In order to promote international uniformity, IEC National Committees undertake to apply IEC Publications transparently to the maximum extent possible in their national and regional publications. Any divergence between any IEC Publication and the corresponding national or regional publication shall be clearly indicated in the latter.
- 5) IEC provides no marking procedure to indicate its approval and cannot be rendered responsible for any equipment declared to be in conformity with an IEC Publication.
- 6) All users should ensure that they have the latest edition of this publication.
- 7) No liability shall attach to IEC or its directors, employees, servants or agents including individual experts and members of its technical committees and IEC National Committees for any personal injury, property damage or other damage of any nature whatsoever, whether direct or indirect, or for costs (including legal fees) and expenses arising out of the publication, use of, or reliance upon, this IEC Publication or any other IEC Publications.
- 8) Attention is drawn to the Normative references cited in this publication. Use of the referenced publications is indispensable for the correct application of this publication.
- 9) Attention is drawn to the possibility that some of the elements of this IEC Publication may be the subject of patent rights. IEC shall not be held responsible for identifying any or all such patent rights.

International Standard IEC 61280-4-1 has been prepared by subcommittee 86C: Fibre optic systems and active devices, of IEC technical committee 86: Fibre optics.

This second edition cancels and replaces the first edition, published in 2003, and constitutes a technical revision.

The main changes with respect to the previous edition are listed below:

- An additional measurement method based on optical time domain reflectometry (OTDR) is documented, with guidance on best practice in using the OTDR and interpreting OTDR traces.
- The requirement for the sources used to measure multimode fibres is changed from one based on coupled power ratio (CPR) and mandrel requirement to one based on measurements of the near field at the output of the launching test cord.

- Highlighting the importance of, and giving guidance on, good measurement practices including cleaning and inspection of connector end faces.

The text of this standard is based on the following documents:

FDIS	Report on voting
86C/879/FDIS	86C/892/RVD

Full information on the voting for the approval of this standard can be found in the report on voting indicated in the above table.

This publication has been drafted in accordance with the ISO/IEC Directives, Part 2.

A list of all the parts in the IEC 61280 series, under the general title *Fibre-optic communication subsystem test procedure*, can be found on the IEC website.

For the Part 4, the new subtitle will be *Installed cable plant*. Subtitles of existing standards in this series will be updated at the time of the next edition.

The committee has decided that the contents of this publication will remain unchanged until the maintenance result date indicated on the IEC web site under "<http://webstore.iec.ch>" in the data related to the specific publication. At this date, the publication will be

- reconfirmed,
- withdrawn,
- replaced by a revised edition, or
- amended.

A bilingual version of this publication may be issued at a later date.

## FIBRE-OPTIC COMMUNICATION SUBSYSTEM TEST PROCEDURES –

### Part 4-1: Installed cable plant – Multimode attenuation measurement

#### 1 Scope

This part of IEC 61280-4 is applicable to the measurement of attenuation of installed fibre-optic cabling using multimode fibre, typically in lengths of up to 2 000 m. This cabling can include multimode fibres, connectors, adapters and splices.

Cabling design standards such as ISO/IEC 11801, ISO/IEC 24702 and ISO/IEC 24764 contain specifications for this type of cabling. ISO/IEC 14763-3, which supports these design standards, makes reference to the test methods of this standard.

In this standard, the fibre types that are addressed include category A1a (50/125  $\mu\text{m}$ ) and A1b (62,5/125  $\mu\text{m}$ ) multimode fibres, as specified in IEC 60793-2-10. The attenuation measurements of the other multimode categories can be made, using the approaches of this standard, but the source conditions for the other categories have not been defined.

#### 2 Normative references

The following referenced documents are indispensable for the application of this document. For dated references, only the edition cited applies. For undated references, the latest edition of the referenced document (including any amendments) applies.

IEC 60825-2, *Safety of laser products – Part 2: Safety of optical fibre communication systems (OFCS)*

IEC 61280-1-3, *Fibre optic communication subsystem basic test procedures – Part 1-3: Test procedures for general communication subsystems – Central wavelength and spectral width measurement*

IEC 61280-1-4, *Fibre optic communication subsystem test procedures – Part 1-4: General communication subsystems – Light source encircled flux measurement method<sup>1</sup>*

IEC 61300-3-35, *Fibre optic interconnecting devices and passive components – Basic test and measurement procedures – Part 3-35: Examinations and measurements – Fibre optic cylindrical connector endface visual inspection*

IEC 61315, *Calibration of fibre-optic power meters*

IEC 61745, *End-face image analysis procedure for the calibration of optical fibre geometry test sets*

IEC 61746, *Calibration of optical time-domain reflectometers (OTDRs)*

---

<sup>1</sup> A new edition is in preparation.

### 3 Terms, definitions, graphical symbols and acronyms

For the purposes of this document, the following terms, definitions, graphical symbols and acronyms apply.

#### 3.1 Terms and definitions

##### 3.1.1

##### **attenuation**

reduction of optical power induced by transmission through a medium such as cabling, given as  $L$  (dB)

$$L = 10 \log_{10}(P_{in}/P_{out})$$

where  $P_{in}$  and  $P_{out}$  are the power, typically measured in mW, into and out of the cabling

##### 3.1.2

##### **light source power meter**

##### **LSPM**

test system consisting of a light source (LS), power meter (PM) and associated test cords used to measure the attenuation of installed cable plant

##### 3.1.3

##### **optical time domain reflectometer**

##### **OTDR**

test system consisting of an optical time-domain reflectometer and associated test cords used to characterize and measure the attenuation of installed cable plant and specific elements within that cable plant

##### 3.1.4

##### **test cord**

terminated optical fibre cord used to connect the optical source or detector to the cabling, or to provide suitable interfaces to the cabling under test

NOTE There are five types of test cords:

- launch cord: used to connect the light source to the cabling;
- receive cord: used to connect the cabling to the power meter (LSPM only);
- tail cord: attached to the far end of the cabling when an OTDR is used at the near end. This provides a means of evaluating attenuation of the whole of the cabling including the far end connection;
- adapter cord: used to transition between sockets or other incompatible connectors in a required test configuration;
- substitution cord: a test cord used within a reference measurement which is replaced during the measurement of the loss of the cabling under test.

##### 3.1.5

##### **bidirectional measurement**

two measurements of the same optical fibre, made by launching light into opposite ends of that fibre

##### 3.1.6

##### **configuration**

form or arrangements of parts or elements such as terminations, connections and splices

##### 3.1.7

##### **encircled flux**

##### **EF**

fraction of cumulative near field power to total output power as a function of radial distance from the optical centre of the core

[from IEC 61280-1-4]

### 3.1.8

#### **reference grade termination**

**connector** (3.1.9) **plug** (3.1.10) with tightened tolerances terminated onto an optical fibre with tightened tolerances such that the expected loss of a connection formed by mating two such assemblies is less than or equal to 0,1 dB

EXAMPLE: as an example, the core diameter tolerance may need to be  $\pm 0,7$  micron (ffs). Other fibre tolerances are ffs.

NOTE 1 An adapter (3.1.11), required to assure this performance, may be considered to be part of the reference grade termination where required by the test configuration (3.1.6)

NOTE 2 This definition remains as a point under study. When a more complete definition is available in another document, this definition will be replaced by a reference.

### 3.1.9

#### **connector**

component normally attached to an optical cable or piece of apparatus, for the purpose of providing frequent optical interconnection/disconnection of optical fibres or cables

{Definition 2.6.1 of IEC/TR 61931}

### 3.1.10

#### **plug**

male-type part of a connector

[Definition 2.6.2 of IEC/TR 61931]

### 3.1.11

#### **adapter**

female-part of a connector in which one or two plugs are inserted and aligned

[Definition 2.6.4 of IEC/TR 61931:1998]

### 3.1.12

#### **socket-style connector**

connector for which the adapter, including any alignment device, is integrated with, and permanently attached to the connector plug on one side of the connection

NOTE Examples include the SG and many harsh environment connectors.

### 3.1.13

#### **reference test method**

#### **RTM**

test method used in the resolution of a dispute

## 3.2 Graphical symbols

The following graphic symbols for different connection options have been adapted from IEC 61930.



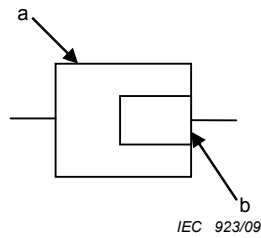

Figure 1a – Socket and plug assembly

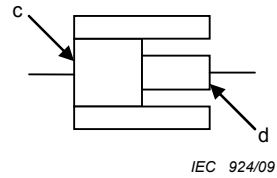

Figure 1b – Connector set (plug, adapter, plug)

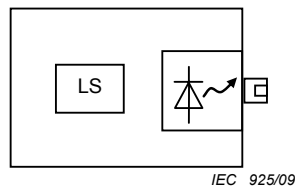

Figure 1c – Light source

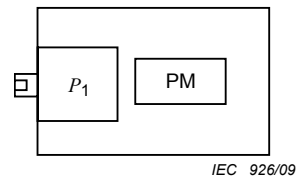

Figure 1d – Power meter

**Key**

a	socket	d	plug inserted into plug-adapter assembly
b	plug	LS	light source
c	plug-adapter assembly	PM	power meter

**Figure 1 – Connector symbols**

NOTE 1 In Figure 1b, and elsewhere in this standard, the plugs are shown with different sizes to indicate directionality where the cabling has adapters pre-attached and the test cord does not, or vice versa. In Figure 1b, the plug on the left has the adapter pre-attached.

NOTE 2 Reference grade terminations are shown shaded with grey.

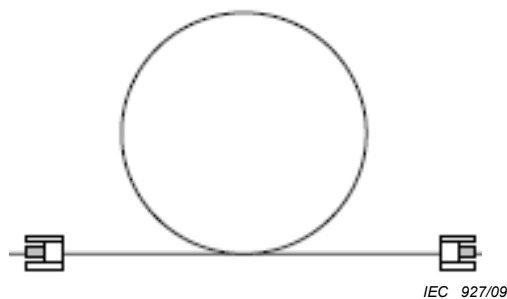

Figure 2 – Symbol for cabling under test

In the figures that illustrate the measurement configurations in Annexes A through D, the cabling under test is illustrated by a loop as shown in Figure 2. Although illustrated as just a loop of fibre, it may contain additional splices and connectors in addition to the terminal connectors. Note that for purposes of measuring the attenuation of this cabling, the losses associated with the terminal connectors are considered separately from the cabling itself.

NOTE 3 In Figure 2, the cabling is shown with adapters pre-attached and the plugs going into them are associated with reference grade test cord plugs.

### 3.3 Acronyms

The following acronyms are used:

EF	encircled flux
LSA	least squares approximation
LSPM	light source power meter
OTDR	optical time domain reflectometer
RTM	reference test method

## 4 Measurement methods

### 4.1 General

Four measurement methods are designated. The four measurement methods use test cords to interface to the cable plant and are designated as follows:

- one-cord reference method;
- three-cord reference method;
- two-cord reference method;
- optical time domain reflectometer (OTDR) method.

The first three methods use an optical light source and power meter (LSPM) to measure input and output power levels of the cabling under test to determine the attenuation. The main functional difference between these methods is the way the input power level, known as the reference power level, is measured and hence the inclusion or exclusion of the losses associated with the connections to the cabling under test, and the associated uncertainties of these connections. The process of measuring the input power level is commonly referred to as 'taking the reference power level,' or 'normalization'.

The use of the term 'reference' in the description of the test methods refers to the process of measuring the input power, not the status of the test.

The one-cord reference method includes the attenuation associated with connections at both ends of the cabling under test. The three-cord reference method attempts to exclude the attenuation of the connections of both ends of the cabling under test. The two-cord reference method normally includes the attenuation associated with one of the connections of the cabling under test.

NOTE The maximum allowed cabling attenuation specified (e.g. optical power budget or channel insertion loss) for a transmission system normally excludes the connections made to the transmission equipment. It is therefore appropriate to use the three cord reference method where the cabling under test is intended to be connected directly to transmission equipment.

The OTDR method emits short light impulses into the cabling and measures the backscattered power as a function of propagation time delay or length along the fibre. This also allows the determination of individual cabling component attenuation values. It does not require a separate reference measurement to be completed. Requirements for the launch cord and tail cord are defined in Annex D.

Uncertainties in the specific methods are documented in respective annexes. An overview of these uncertainties is given in 4.2.

General requirements for apparatus, procedures and calculations common to all methods are given in the main text of this standard. Requirements that are specific to each particular

method are documented in Annexes A through D. The main text also includes related procedures such as connector end face cleaning and inspection.

## 4.2 Cabling configurations and applicable test methods

This standard assumes that the installed cabling takes one of three forms shown in Table 1. If the cabling is terminated with an adapter, the test cord shall be terminated with a plug and vice versa.

**Table 1 – Cabling configurations**

Configuration	Description
A	Adapters attached to plugs or sockets attached to both ends of the cabling
B	Plugs on both ends
C	Mixed, where one end of the cabling is terminated with an adapter and the other end is terminated with a plug

The variations in test method used to measure the cabling are dependent on the cabling configuration. For example, a common cabling configuration is that of having adapters or sockets on both ends of the cabling (e.g. within patch panels) awaiting connection to electronic equipment with an equipment cord. This corresponds to configuration A. In this case, the one-cord reference method is used to include the losses associated with both end connectors of the cabling. Another example is a cabling configuration for which equipment cords are installed on both ends of the cabling and are awaiting connection to electronic equipment. This corresponds to configuration B. In this case, a three-cord reference method is used to exclude the loss of the end plug connections.

The configuration A, B or C defines the test methods that should be applied as described in Table 2. The reference test method offers the best measurement accuracy. Alternative test methods may be called up in specific circumstances or by other standards but are subject to reduced measurement accuracy compared with the reference test method. Reference grade terminations on the test cords as described in 5.2.3, 5.3 and 5.4 shall be used for the resolution of disputes, unless otherwise agreed.

**Table 2 – Test methods and configurations**

Configuration	RTM	Alternative method
A	Annex A	Annex B <sup>a</sup>
B	Annex B	–
C	Annex C	Annex B
<sup>a</sup> For situations where pinned/unpinned or plug/socket style connectors are used such as MTRJ, SG or other harsh environment connector but the power meter does not accept the unpinned or plug connector of the launch cord, Figure C.3 may be used.		
NOTE These configurations, RTMs and annexes are ordered according to the frequency in which different configurations are typically encountered.		

## 4.3 Overview of uncertainties

### 4.3.1 General

The uncertainties are affected by the type of fibre, the terminations of the cabling and the measurement method used. See Annex F for some more detailed considerations.

### 4.3.2 Test cords

A main source of uncertainty involves the connection of the terminated cabling to the test equipment. The attenuation associated with the test cord connections may be different from the attenuation present when the cabling is connected to other cords or transmission equipment. The use of reference grade terminations on the test cords reduces this uncertainty and improves reproducibility of the measurement, but the allocation of acceptable loss is changed as listed in Table F.1.

### 4.3.3 Launch conditions at the connection to the cabling under test

For all methods, an additional source of uncertainty is related to the characteristic of the optical source at the face of the launch cord. Different regions of the intensity vs. radial position are attenuated differently, depending on how many connections are found in the cabling and the radial offsets between fibre cores at these connection points. Usually, the outer region is attenuated more than the inner region. This is known as differential mode attenuation.

To obtain measurements that are relevant to the types of sources found in transmission equipment, a restricted launch, not an overfilled launch, shall be used. The limits on this restricted launch (see Annex E) are defined to yield attenuation variations of less than  $\pm 10\%$  of the target attenuation for a number of defined conditions when the core diameter of the launch cord fibre is equal to the specification mid-range (the nominal value for the fibre types).

For the OTDR method, the differential mode attenuation occurs not only from the mode coupling resulting from forward transmission through each connection, but also due to the mode coupling resulting from the backscattered power through each connection in the reverse direction. The limits on the near field of the launching cord provide some control on this, but it is not as well quantified as it is for the LSPM methods. There can also be some additional differential mode attenuation at the splitter within the OTDR on the path to the detector that is not subject to an external test. bidirectional testing (see Clause G.6) may reduce this uncertainty.

### 4.3.4 Optical source

The following sources of uncertainties are relevant to the attenuation measurements:

- Wavelength of the source – causes fibre attenuation variations between source wavelength and cabling system transmitter wavelength.
- Spectral width – wider spectral widths cause fibre attenuation variations between the source wavelength and the cabling system transmitter wavelength, narrower spectral widths can introduce modal noise.
- Power meter nonlinearity – the linearity error of the power meter.

### 4.3.5 Output power reference

For methods using LSPM, one of the main sources of uncertainty is the variable coupling efficiency of the light source to the launch cord due to mechanical tolerances. To minimize this uncertainty, a reference power reading should be made whenever the connection is disturbed by stress on the connector or disconnection.

For LSPM methods, a reference measurement shall be made to determine the output power of the launch cord which will be coupled to the cable or cable plant under test. This measurement should be made each time the launch cord is attached to the source, as this coupling may be slightly different each time it is done.

### 4.3.6 Received power reference

If the power meter has a detector large enough to capture all the incident light then the coupling of the receive cord to the power meter is minimal and shall be discounted. In other circumstances (which may include the use of pigtailed detectors), the uncertainty introduced shall be included in the overall measurement uncertainty.

## 5 Apparatus

### 5.1 General

Apparatus requirements that are specific to particular methods are found in Annexes A to D. Some of the requirements common to the apparatus of LSPM methods are included in this clause.

### 5.2 Light source

#### 5.2.1 Stability

The light source is defined at the output of the launch cord. This is achieved by transmitting the output of a suitable radiation source, such as laser or light emitting diode into the launching cord. The source shall be stable in position, wavelength and power over the duration of the entire measurement procedure.

#### 5.2.2 Spectral characteristics

The spectral width of the light source shall meet the requirements of Table 3 when measured in accordance with IEC 61280-1-3.

**Table 3 – Spectral requirements**

Centroidal wavelength nm	Spectral width range, full width at half maximum nm
850 ± 30	30 <sup>a</sup> to 60
1 280 – 1 350	100 <sup>a</sup> to 140
<sup>a</sup> The minimum of the spectral width range applies to LSPM methods only.	

#### 5.2.3 Launch cord

The optical fibre within the launch cord at the connection to the cabling under test shall be of the same type, in terms of core diameter and numerical aperture, but not necessarily bandwidth, as the optical fibre within the cabling under test. Except for the OTDR method, the launch cord shall be 1 m to 5 m in length. See Annex D for the length of the OTDR launch cord.

The requirements on the near field profile coming from the launch cord that are found in Annex E shall be met. The required launch conditions can be achieved by including appropriate equipment inside the light source, or by applying mode controlling or conditioning devices on or in series with the launch cord.

The connector or adapter terminating the launch cord shall be compatible with the cabling and should be of reference grade to minimize the uncertainty of measurement results.

### **5.3 Receive or tail cord**

The optical fibre within the receive or tail cord shall be of the same type, nominal core diameter and nominal numerical aperture as the optical fibre within the cabling under test.

The connector or adapter terminating the launch cord shall be compatible with the cabling and should be of reference grade to minimize the uncertainty of measurement results.

The termination of a receive cord at the connection to the power meter shall be compatible with that of the power meter.

Where unidirectional testing is carried out, the remote end of the tail cord used for OTDR testing has no requirement for a reference grade termination. Where bi-directional testing is carried out, the tail cord becomes the launch cord (See Annex I) and shall comply with 5.2.3.

### **5.4 Substitution/dummy cord**

The optical fibre within the substitution/dummy cord shall be of the same category, nominal core diameter and nominal numerical aperture as the optical fibre within the cabling under test.

The connector or adapter terminating the launch cord shall be compatible with the cabling and should be of reference grade to minimize the uncertainty of measurement results.

### **5.5 Power meter – LSPM methods only**

The power meter shall be capable of measuring the range of power normally associated with the cabling, including considerations on the power launched into the cabling. The power meter shall meet the calibration requirements of IEC 61315. The meter shall have a detecting surface of sufficient size to capture all the power coming from the fibre that is put into it. If a pigtail is used, the pigtail fibre shall be sufficiently large to capture all the power coming from the test cord.

### **5.6 OTDR apparatus**

Figure 3 is a schematic of the OTDR apparatus shown with a simple attachment point. Annex D has some more detailed requirements for the length of the launch cord and other aspects related to the OTDR measurement. The other requirements of 5.1 apply.

For high precision and repeatable measurements, it is recommended, but not mandatory, to use, either before or after the splitter, a speckle scrambler functionally equivalent to the fibre shaker described in 61280-1-4 in order to minimize the effects of coherence modal noise.

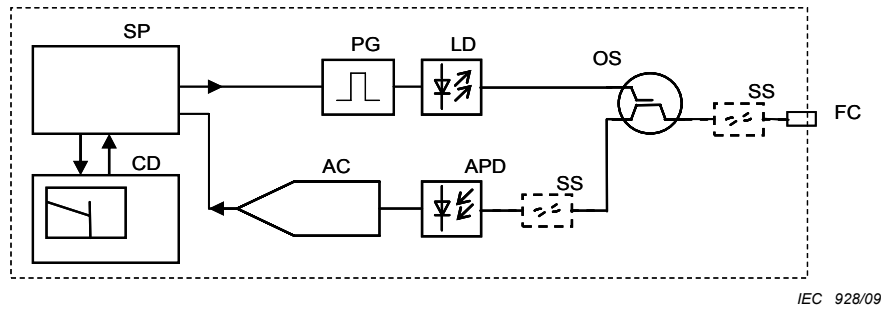

**Key**

- PG pulse generator
- LD laser diode
- OS optical splitter
- SS speckle scrambler (optional)
- FC front panel connector
- APD avalanche photo diode
- AC amplifier and converter
- SP signal processor
- CD control and display

**Figure 3 – OTDR schematic**

**5.7 Connector end-face cleaning and inspection equipment**

Cleaning equipment (including apparatus, materials, and substances) and the methods to be used shall be suitable for the connectors to be cleaned. Connector suppliers' instructions shall be consulted where doubt exists as to the suitability of particular equipment and cleaning methods.

A microscope compatible with IEC 61300-3-35, low resolution method, is required to verify that the fibre and connector end faces of the test cords are clean and free of damage. Microscopes with adaptors that are compatible with the connectors used are required.

**5.8 Adapters**

Where appropriate, adapters shall be compatible with the connector style being used and shall allow the required performance of reference grade terminations to be achieved.

**6 Procedures**

**6.1 General**

Procedure requirements that are specific to particular methods are found in Annexes A through D.

LSPM methods require a reference measurement to be taken prior to measuring the cabling. Equipment should be assessed before commencing testing to ascertain how frequently reference measurements should be taken. Generally this should be before the equipment has drifted more than 0,1 dB. The test environment (particularly the temperature) may affect the frequency of re-referencing.

## **6.2 Common procedures**

### **6.2.1 Care of the test cords**

The ends of the test cords shall be free of dirt or dust and shall be scratch free in accordance with IEC 61300-3-35. If contamination is seen, clean using the equipment and methods of 5.7.

When the test cords are not in use, the ends should be capped and they should be stored in kink-free coils of a diameter greater than the minimum bending diameter.

### **6.2.2 Make reference measurements (LSPM methods only)**

The output power from the launch cord for each test wavelength shall be measured and shall be recorded in an appropriate format.

### **6.2.3 Inspect and clean the ends of the fibres in the cabling**

The ends of the cabling shall be free of contamination (e.g. dirt and dust) in accordance with IEC 61300-3-35. If contamination is seen, the connector end face shall be cleaned using the equipment and methods of 5.6.

### **6.2.4 Make the measurements**

This is an iterative process for each fibre in the cabling including:

- attachment of individual fibres to the launch and receive or tail cords;
- completing the measurement at each wavelength;
- storing or recording the results.

NOTE For LSPM methods, the power meter and receive test cord may have to be moved to the far end of the cabling or a second power meter and receive test cord may be used.

### **6.2.5 Make the calculations**

Make the calculations to determine the difference between the reference measurement and the test measurements and record the final result together with other information in accordance with Clause 8.

## **6.3 Calibration**

Power meters and OTDR equipment shall be calibrated in accordance with IEC 61315 and IEC 61746, respectively.

The equipment used shall have a valid calibration certificate in accordance with the applicable quality system for the period over which the testing is done.

## **6.4 Safety**

All tests performed on optical fibre communication systems, or that use a laser or LED in a test set, shall be carried out with the safety precautions in accordance with IEC 60825-2.

NOTE Light sources used for testing multimode fibre optic cabling will usually be Class 1 products and therefore considered safe.

## **7 Calculations**

The calculations for each method are given in the respective annexes.



## **8 Documentation**

### **8.1 Information for each test**

- Test procedure and method
- Measurement results including:
  - Attenuation (dB)
    - Reference power level (dBm) (LSPM methods only)
    - OTDR trace(s) (OTDR method only, from both directions when bidirectional measurements have been done)
  - Wavelength (nm)
  - Fibre type
  - Termination location
  - Fibre identifier
  - Cable identifier
- Date of test.

### **8.2 Information to be available**

- Details of the spectral characteristics of the light source
- Calibration records
- Information indicating compliance with the required launch condition in accordance with 5.2.3.
- Details of the test cords used for the measurements

## **Annex A** (normative)

### **One-cord reference method**

#### **A.1 Applicability of test method**

The one-cord reference method measurement includes the losses of both connections to the cabling under test. It is the RTM for measurement of installed cabling plant of Configuration A (see 4.1).

This method is written for the case when one single fibre is being measured at a time. If multiple fibres are measured simultaneously with multi-fibre connectors, the requirements of each interface shall be met as though it were a single connector as referenced in the following text. If bidirectional measurements are required, the procedures are repeated by launching into the other end.

#### **A.2 Apparatus**

The light source, power meter and test cords defined in the main text are required.

This is called the “one-cord reference method” because only one (the launch) test cord is used for the reference measurement. However a second test (receive) cord is needed. The performance of the test cords should be verified before testing commences. This is done by connecting the receive cord to the launch cord and measuring the loss of the connection. See Annex H for more information.

This method calls for the launch cord to be attached directly to the power meter for the reference measurement. This assumes that the connectors used in the cabling are compatible with the connector used in the power meter.

This method also assumes that:

- The connector on the power meter is compatible with that of the cabling under test into which the launch cord is connected. Where appropriate an adapter that introduces no additional measurement uncertainty may be attached to the power meter. The alternative method (Annex B) may be used provided that the increased measurement inaccuracy of that method is recognized and appropriately modified test limits are applied.
- The launch cord is not disconnected from the light source between a reference measurement and a test measurement. If either the design of the test equipment or the design of the cabling under test makes such a disconnection unavoidable then the alternative method (Annex B) may be used, provided that the increased measurement inaccuracy of that method is recognized and appropriately modified test limits are applied.

#### **A.3 Procedure**

- Connect the light source and power meter using the launch cord (TC1) as shown in Figure A.1.
- Record the measured optical power,  $P_1$ , which is the reference power measurement.
- Disconnect the power meter from TC1.

NOTE Do not disconnect TC1 from the light source without repeating a reference measurement.

- Connect the power meter to the receive cord (TC2).
- Connect TC1 and TC2 to the cabling under test as shown in Figure A.2.

- Record the measured optical power,  $P_2$ , which is the test power measurement.

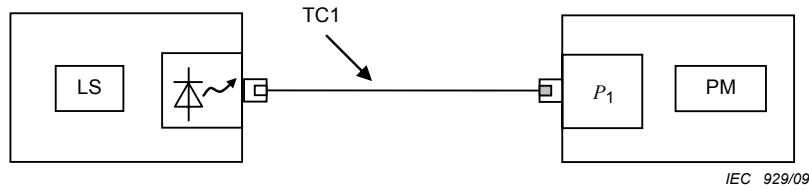

**Key**

- LS light source
- TC1 launch cord
- PM power meter

**Figure A.1 – Reference measurement**

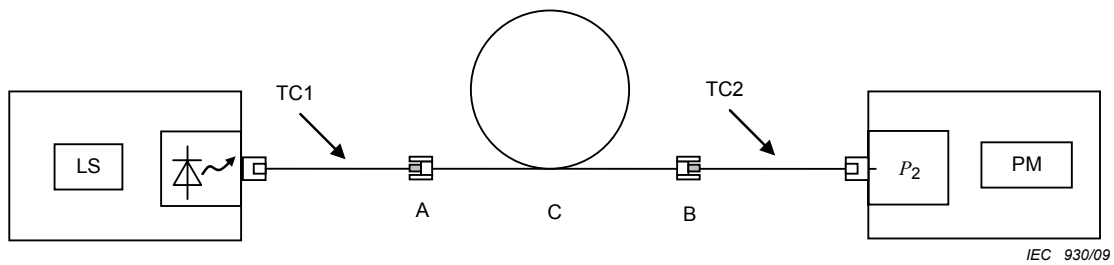

**Key**

- LS light source
- TC1 launch cord
- C cabling under test
- TC2 receive cord
- PM power meter

**Figure A.2 – Test measurement**

NOTE Reference grade terminations are shaded.

**A.4 Calculation**

The attenuation,  $L$ , is given by:

$$L = 10 \log_{10} (P_1 / P_2) \text{ (dB)} \tag{A.1}$$

**A.5 Components of reported attenuation**

The attenuating elements are identified in Figures A.1 and A.2. These are the attenuation of the cabling,  $C$ , and various connection attenuation values, in dB. The reported attenuation,  $L$ , is:

$$L = A + B + C \tag{A.2}$$

Differences between the result reported by this method and the other LSPM methods are illustrated in F.1.

## **Annex B** (normative)

### **Three-cord reference method**

#### **B.1 Applicability of test method**

The three-cord reference method attempts to exclude the losses of both connections to the cabling under test. It is the RTM for measurement of installed cabling plant of Configuration B (see 4.1) and in certain circumstance, or as directed by external standards, may be used in place of the test methods specified in Annex A and Annex C.

This method is written for the case when a single fibre is being measured at a time. If multiple fibres are measured simultaneously with multi-fibre connectors, the requirements of each interface shall be met as though it were a single connector as referenced in the following text. If bidirectional measurements are required, the procedures are repeated by launching into the other end. See Annex H for more information.

#### **B.2 Apparatus**

The light source, power meter and test cords defined in the main text are required.

Three test cords are used. The attenuation values of the connections between these cords are critical to the uncertainty of the measurement.

#### **B.3 Procedure**

- Connect the launch cord (TC1) and receive cord (TC2) to the light source and power meter as shown in Figure B.1.
- Connect the substitution cord (TC3) between TC1 and TC2.
- Record the measured optical power,  $P_1$ , which is the reference power measurement.

NOTE Do not disconnect TC1 from the light source without repeating a reference measurement.

- Replace the substitution cord with the cabling under test (leaving the adapters attached to TC1 and TC2) as shown in Figure B.2.
- Record the measured optical power,  $P_2$ , which is the test power measurement.

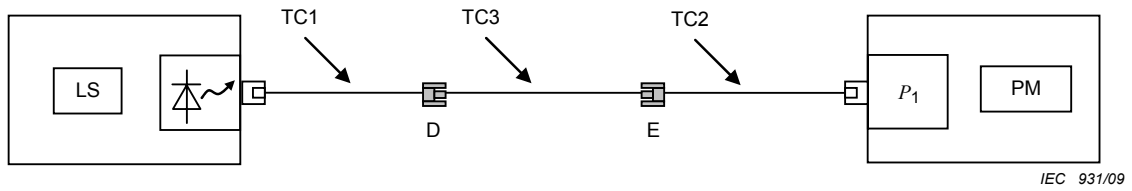

**Key**

- |     |                   |     |              |
|-----|-------------------|-----|--------------|
| LS  | light source      | TC2 | receive cord |
| TC1 | launch cord       | PM  | power meter  |
| TC3 | substitution cord |     |              |

**Figure B.1 – Reference measurement**

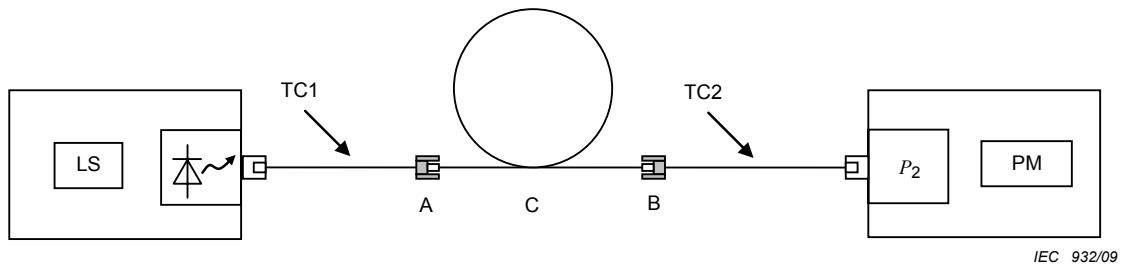

**Key**

- |     |                    |     |              |
|-----|--------------------|-----|--------------|
| LS  | light source       | TC2 | receive cord |
| TC1 | launch cord        | PM  | power meter  |
| C   | cabling under test |     |              |

**Figure B.2 – Test measurement**

NOTE Reference grade terminations are shaded.

**B.4 Calculations**

The attenuation,  $L$ , is given by:

$$L = 10 \log_{10} (P_1 / P_2) \text{ (dB)} \tag{B.1}$$

**B.5 Components of reported attenuation**

The attenuating elements are identified in Figures B.1 and B.2. These are attenuation values of the cabling,  $C$ , and various connection attenuation values, in dB. The reported attenuation,  $L$ , is:

$$L = A + B + C - D - E \tag{B.2}$$

$D$  and  $E$  are the attenuation values of the connections in the reference test set-up and together include the attenuation over the length of TC3, which is negligible.

Differences between the result reported by this method and the other LSPM methods are illustrated in Clause F.1.

## **Annex C** (normative)

### **Two-cord reference method**

#### **C.1 Applicability of test method**

Two variants are given for the two-cord reference method. Figure C.2 shows the set-up for the case where one end is terminated with a plug-adaptor assembly and the other is terminated with a plug. It includes the loss of one of the connections to the cabling under test. It is the RTM for measurement of installed cabling plant of configuration C (see 4.1).

Figure C.3 shows the set-up for the case where both ends are socketed or pinned and the launch cord connector is incompatible with the power meter. It includes the losses of both connections to the cabling under test. It is an alternative method for measurement of installed cabling plant of configuration A (see 4.1).

This method is written for the case when a single fibre is being measured at a time. If multiple fibres are measured simultaneously with multi-fibre connectors, the requirements of each interface shall be met as though it were a single connector as referenced in the following text. If bidirectional measurements are required, the procedures are repeated by launching into the other end. See Annex H for more information.

#### **C.2 Apparatus**

The light source, power meter and test cords defined in the main text are required.

#### **C.3 Procedure**

- Connect the launch cord (TC1) and receive cord (TC2) to the light source and power meter and to each other as shown in Figure C.1.
- Record the measured optical power,  $P_1$ , which is the reference power measurement.
- Disconnect TC1 and TC2.

NOTE Do not disconnect TC1 from the light source without repeating a reference measurement.

- Insert either
  - the cabling under test as shown in Figure C.2,
  - the adapter cord AC and the cabling under test as shown in Figure C.3.
- Record the measured optical power,  $P_2$ , which is the test power measurement.

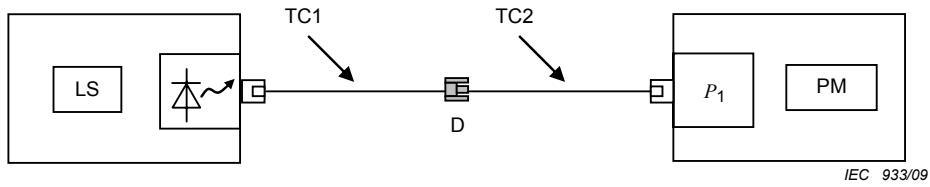

**Key**

- |     |              |     |              |
|-----|--------------|-----|--------------|
| LS  | light source | TC2 | receive cord |
| TC1 | launch cord  | PM  | power meter  |

**Figure C.1 – Reference measurement**

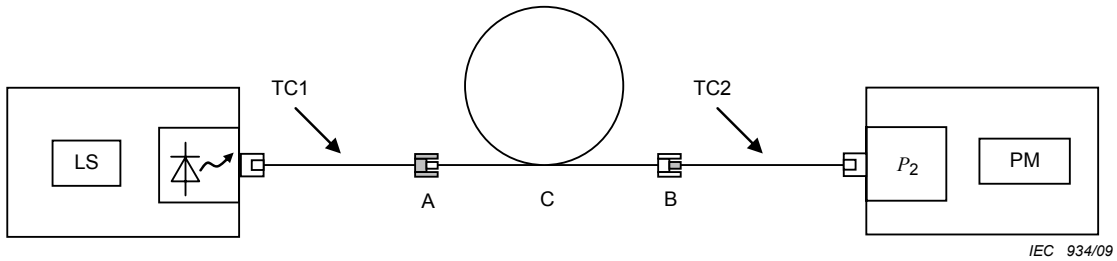

**Key**

- |     |                    |     |              |
|-----|--------------------|-----|--------------|
| LS  | light source       | TC2 | receive cord |
| TC1 | launch cord        | PM  | power meter  |
| C   | cabling under test |     |              |

**Figure C.2 – Test measurement**

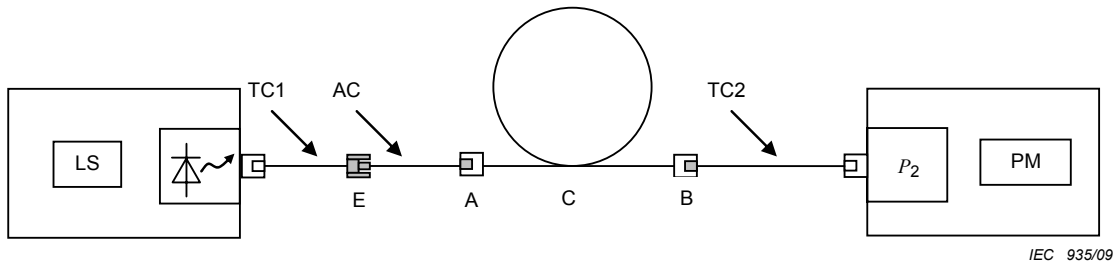

**Key**

- |     |                    |     |              |
|-----|--------------------|-----|--------------|
| LS  | light source       | AC  | adapter cord |
| TC1 | launch cord        | TC2 | receive cord |
| C   | cabling under test | PM  | power meter  |

**Figure C.3 – Test measurement for plug-socket style connectors**

NOTE Reference grade terminations are shaded.

#### C.4 Calculations

The attenuation,  $L$ , is given by:

$$L = 10 \log_{10} (P_1 / P_2) \text{ (dB)} \quad (\text{C.1})$$

#### C.5 Components of reported attenuation

The attenuating elements are identified in Figures C.1, C.2, and C.3. These are of the cabling, C, and various connection losses, in dB.

For the case of Figure C.2, the reported attenuation,  $L$ , is:

$$L = A + B + C - D \quad (\text{C.2})$$

For the case of Figure C.3, the reported attenuation,  $L$ , is:

$$L = A + B + C + E - D \quad (\text{C.3})$$

Differences between the result reported by this method and the other LSPM methods are illustrated in Clause F.1.



## **Annex D** (normative)

### **Optical time domain reflectometer**

#### **D.1 Applicability of test method**

This method is written for the case when a single fibre is being measured by means of an optical time domain reflectometer (OTDR) from one end of a fibre link or channel. When bidirectional measurements (see Clause G.6) are specified, the procedures within this annex are repeated, but from the opposite end of the cabling under test.

#### **D.2 Apparatus**

##### **D.2.1 General**

The OTDR, test cords, and adapters are required for making attenuation and length measurements on the installed cabling. See 5.4 for a schematic of the OTDR equipment.

The test set-up requires a launch test cord and tail test cord. Reflectance, associated with the connectors of the test cords (launch and tail) as well as the cabling, should be minimized.

Index matching fluids or gels between the polished end faces of connectors shall not be used.

The use of the tail cord allows the attenuation of the remote end connection to be measured and therefore the loss of the entire cabling section can be measured. If no tail lead is used then there is no information regarding the remote end connector. In fact not even continuity of the fibre is assured since there may be a break close to the far end, or the fibres may be incorrectly connected somewhere along their length.

##### **D.2.2 OTDR**

The OTDR shall be capable of using a short pulse width ( $\leq 20$  ns) and have sufficient dynamic range ( $> 20$  dB) to achieve a measurement typically in lengths of up to 2 000 m.

The OTDR should have an attenuation dead zone (see G.2.4) less than 10 m following standard connectors (i.e. reflectance of  $-35$  dB).

The near field profile of the light emitted from the end of the launch cord of the OTDR shall meet the requirement of Annex E.

##### **D.2.3 Test cords**

The fibre type and geometrical characteristics of the launching and tail test cord shall be the same as the fibre in the cabling under test and coated so the cladding light is removed. The length of both launching and tail test cord shall be longer than the dead zone created by the pulse width selected for a particular length of fibre to be measured. Suppliers of OTDR equipment should recommend lengths. In addition, these lengths shall be long enough for a reliable straight line fit of the backscatter trace that follows the dead zone.

In the absence of other information the minimum length of launch and tail cords may be determined such that their return delay is equal to the OTDR pulse width multiplied by a suitable factor. For example a factor of 50 multiplied by a typical pulse width of 20 ns would give a return delay of 1 000 ns, equivalent to lengths of 100 m for launch and tail cords

NOTE Bi-directional testing is required if test cord fibre characteristics differ from those of the cabling under test (see Annex I).

The following apply to the preparation of the test cords:

- The attenuation due to induced winding loss should be minimized. To do this, use a minimum radius of 45 mm.
- The cords are terminated at one end with a connector suitable for attachment to the OTDR.
- They are terminated at the other end according to 5.2.3.
- Use ruggedized fibre test leads with, for example a 3 mm outer jacket with strain relief.
- The fibre used in the cord should be protected. This may be done by enclosing most of the length of the cord in a container or by using test cords that are entirely ruggedized. Up to 2 m of fibre length of the cord can extend outside the container to connect the OTDR and the cabling under test.

### D.3 Procedure (test method)

- Connect the test cords and the OTDR source as shown in Figure D.1.
- Configure the OTDR using the following rules:
  - The shortest pulse width possible should be selected that is consistent with acquiring a trace in a reasonable timescale that is sufficiently smooth (i.e. with sufficient signal to noise ratio) to allow effective analysis.
  - The averaging time should not need to be any greater than 3 min per trace. However short averaging times (e.g. < 10 s) generally provides poor results.
  - Refer to Annex I for a better understanding of the OTDR settings.
- Select the appropriate wavelength.
- Record the backscattered trace.

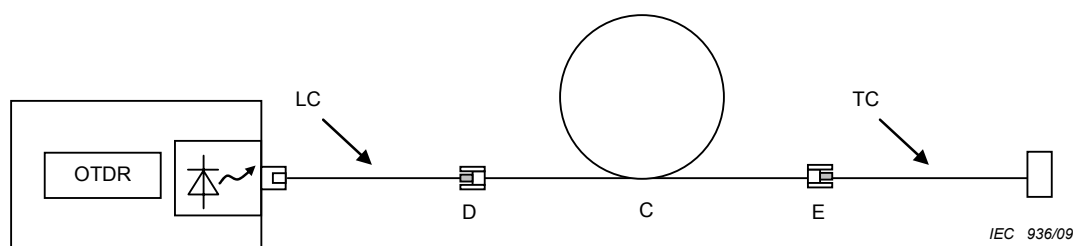

#### Key

OTDR	optical time domain reflectometer
LC	launch cord
C	cabling under test
TC	tail test cord

**Figure D.1 – Test measurement for Method D**

NOTE 1 Reference grade terminations are shaded.

NOTE 2 Figure D.1 shows the set-up for cabling terminated with plug-adaptor assemblies. Other arrangements are equivalent, provided the corresponding reference grade connectors are used at the same points.

### D.4 Calculation

#### D.4.1 General

The attenuation is given by:

$$A = F_1 - F_2 \text{ (dB)} \tag{D.1}$$

Where  $F_1$  and  $F_2$  are the displayed power level of the input and output port of the cabling under test (see Clause D.3).

NOTE The OTDR vertical scale displays five times the logarithm of the received power, plus a constant offset. The OTDR horizontal scale displays distance along the fibre. This is calculated by dividing the measured time delay for the round trip by two, and by the speed of light in the fibre defined by the effective group refractive index of the fibre core.

It is important to properly locate the position of the two connections and to properly define the displayed power levels.

#### D.4.2 Connection location

The two connections of the cabling under test are located at the change of curvature before the two peaks that represent the two connectors.

Figure D.2 illustrates the location of the connectors on a typical trace.

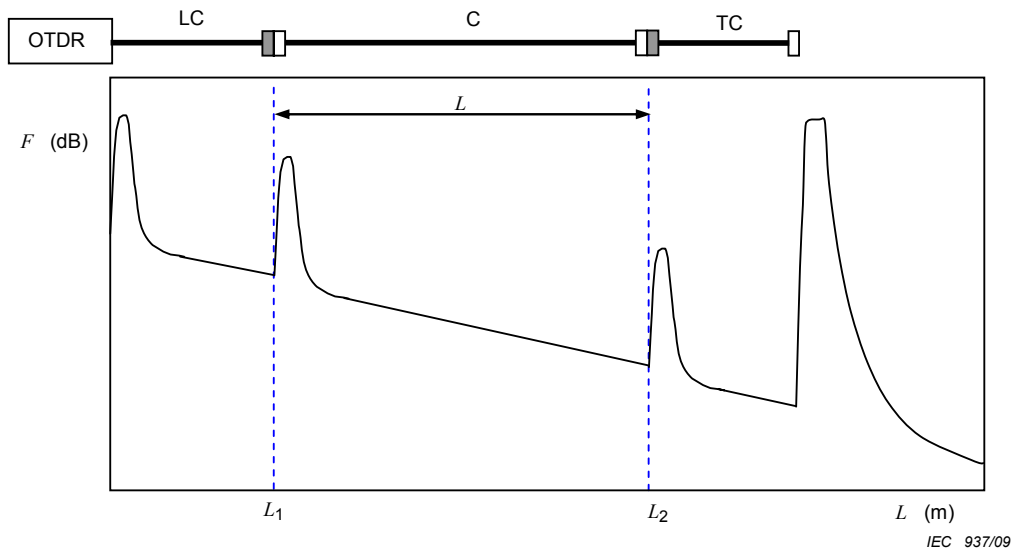

IEC 937/09

#### Key

OTDR	optical time domain reflectometer	$F$	reflected power level
LC	launch cord	$L_1, L_2$	cabling port locations
C	cabling under test	$L$	distance from OTDR output port
TC	tail test cord		

Figure D.2 – Location of the cabling under test ports

### D.4.3 Definition of the power levels $F_1$ and $F_2$

The displayed power level  $F_1$  at location  $L_1$  is defined at the intercept of the linear regression (LSA) obtained from the linear part of the back scattering power provided by the launching test cord and the vertical axis at location  $L_1$ .

The displayed power level  $F_2$  at location  $L_2$  is defined at the intercept of the linear regression (LSA) obtained from the linear part of the back scattering power provided by the tail test cord and the vertical axis at location  $L_2$ .

Figure D.3 illustrates the position of level  $F_1$  and  $F_2$  on a typical trace.

This measurement process is also called five points analysis with LSA. See also Annex G for more details.

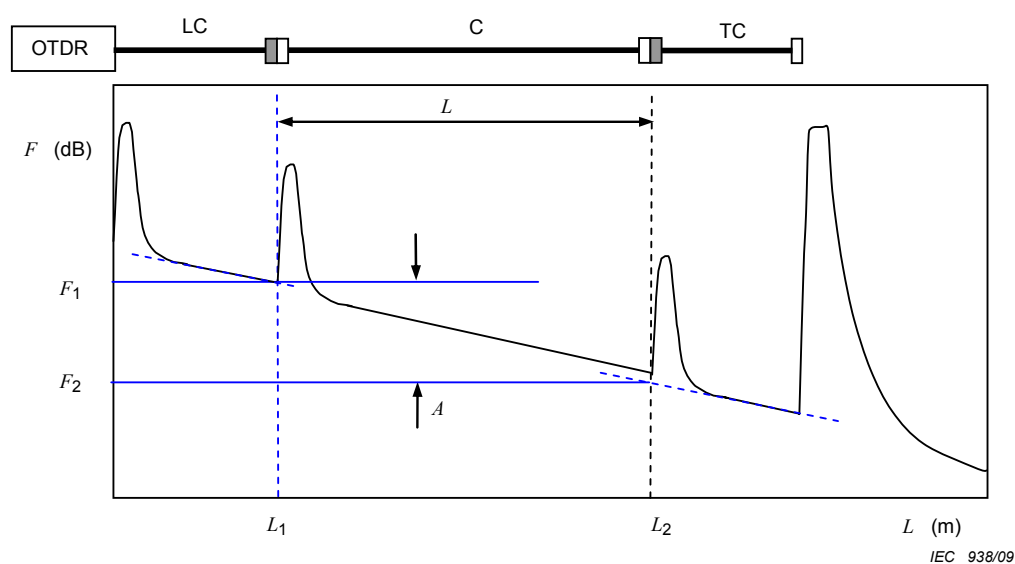

#### Key

OTDR	optical time domain reflectometer	$F$	reflected power level
LC	launching test cord	$L_1, L_2$	cabling port locations
C	cabling under test	$L$	distance from OTDR output port
TC	tail test cord	$F_1, F_2$	displayed power level at $L_1$ and $L_2$
		$A$	attenuation

**Figure D.3 – Graphic construction of  $F_1$  and  $F_2$**

### D.4.4 Alternative calculation

Alternatively the OTDR may provide two other displayed levels  $F_{11}$  and  $F_{12}$  in order to provide a detailed analysis of the trace. See Figure D.4.

The displayed power level  $F_{11}$  at location  $L_1$  is defined at the intercept of the linear regression (LSA) obtained from the linear part of the back scattering power provided by the cabling under test and the vertical axis at location  $L_1$ .

The displayed power level  $F_{21}$  at location  $L_2$  is defined at the intercept of the linear regression (LSA) obtained from the linear part of the back scattering power provided by the cabling under test and the vertical axis at location  $L_2$ .

Three other attenuations are given by:

$$A_1 = F_1 - F_{11} \text{ (dB)} \tag{D.2}$$

$$A_2 = F_{21} - F_2 \text{ (dB)} \tag{D.3}$$

$$A_c = F_{11} - F_{12} \text{ (dB)} \tag{D.4}$$

where  $A_1$  is the attenuation of the near-end connector,  $A_2$  the attenuation of the far-end connector and  $A_c$  the attenuation of the cabling without connectors.

Leading to:

$$A = A_1 + A_c + A_2 \text{ (dB)} \tag{D.5}$$

Assuming calculation errors are negligible, Equation (D.5) has the same validity as Equation (D.1).

In some cases the attenuation  $A_1$ ,  $A_c$  and  $A_2$  may be available in an event table.

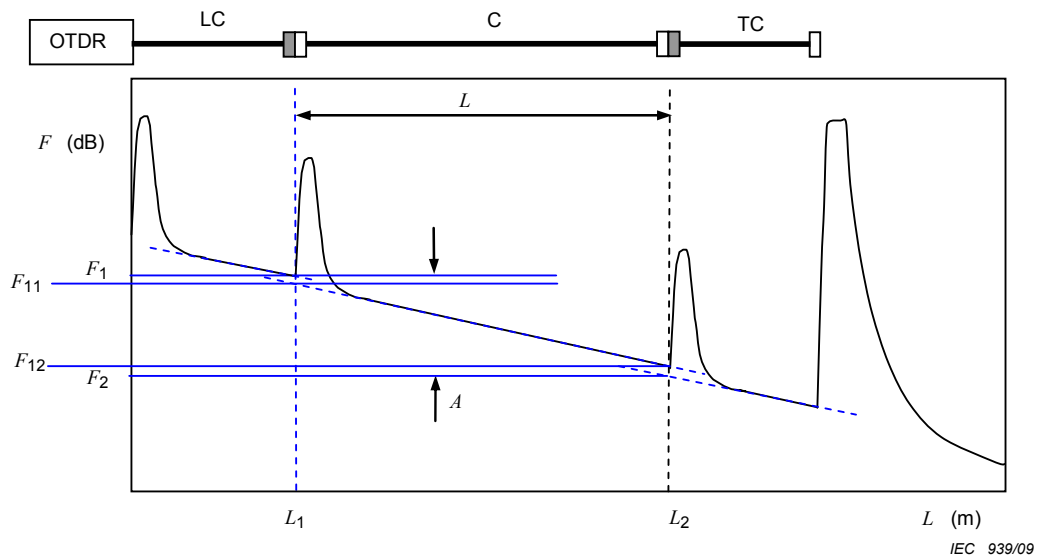

**Key**

OTDR	optical time domain reflectometer	$L_1, L_2$	cabling port locations
LC	launch cord	$L$	distance from OTDR output port
C	cabling under test	$F_1, F_2$	displayed power level at $L_1$ and $L_2$
TC	tail test cord	$F_{11}, F_{12}$	displayed power level at $L_1$ and $L_2$ internal side
$F$	reflected power level	$A$	attenuation

**Figure D.4 – Graphic construction of  $F_1, F_{11}, F_{12}$  and  $F_2$**

## D.5 OTDR uncertainties

The following sources of uncertainties should be considered when reporting the measurement:

- Noise level contribution – errors due to a large amount of Gaussian noise or due to system noise; noise is always higher as backscatter level approaches the noise floor on a logarithmic trace. A large amount of noise on the trace disturbs the linear regressions leading to a wrong evaluation of the different displayed power levels. The noise may be reduced by increasing the averaging time or by increasing the pulse width. When the slope of the linear regression is available (e.g. in dB/km) low slope or high slope are generally associated with an excessive level of noise.
- Backscatter coefficient - Intrinsic property differences between test cords and cabling under test may cause variations in the apparent loss of individual connections. For example, when a fibre with a low backscatter coefficient is connected to one with a higher backscatter coefficient, the OTDR detector will receive more energy from the fibre with the higher backscatter coefficient. This can be interpreted as a reduction in the apparent loss and may even appear as a gain (negative loss). The effect is known as a gainer.
- Strong reflection – non-linear effects of strong reflections cause attenuation errors, attenuation coefficient errors, and dead zone widening.
- Launch conditions – errors resulting from under or over filled launch or cladding light.
- Centre wavelength of OTDR laser – causes fibre attenuation variations between OTDR laser wavelength and cabling system transmitter wavelength.
- Spectral width – related to centre wavelength, wider spectral widths cause fibre attenuation variations between the OTDR laser wavelength and the cabling system transmitter wavelength.
- Cursor location error – error in either software analyzer placement of cursors or manual operation of cursors. This may lead to some error when the slopes of the different fibres are very different.

## Annex E (normative)

### Requirements for the source characteristics for multimode measurement

#### E.1 Encircled flux

The EF definition is in 3.1.5. It is determined from the near field measurement of the light coming from the end of the launching cord.

The near field measurement is conducted in accordance with IEC 61280-1-4. The measured near field result is a function,  $I(r)$ , of radius,  $r$ , away from the optical centre of the core, which is used to generate the encircled flux (EF) function as:

$$EF(r) = \frac{\int_0^r xI(x)dx}{\int_0^R xI(x)dx} \quad (\text{E.1})$$

Where  $R$  is an integration limit defined in IEC 61280-1-4.

#### E.2 Limits on encircled flux

These requirements are suitable for cabling using category A1a and A1b multimode fibres that are defined in IEC 60793-2-10 as 50  $\mu\text{m}$  and 62,5  $\mu\text{m}$  core fibres, both with 125  $\mu\text{m}$  cladding diameter. The requirement for other categories of multimode fibres is under study.

The limits for the encircled flux are derived from a target near field and a set of boundary conditions designed to constrain the variation in attenuation from variations in the source to within  $\pm 10\%$  or  $\pm X$  dB, whichever is largest, of the value that would be obtained if the target launch were used. Only coupling losses are taken into account for these attenuation values.

The theory leading to the EF limits is based on assumptions that include:

- Fibre core refractive index dimension and shape.
- Spectral width.
- Hermite-Gauss model for mode fields.

Deviation from the assumptions can lead to additional attenuation variance. One assumption is that the attenuation is measured with an LSPM method, in which the light is coupled forward through the connections and the backscattered light is not considered. The OTDR method is based on backscattered light which is coupled differently. As a consequence, the understanding of the relationship of the attenuation variance obtained from an OTDR to the encircled flux limits is incomplete.

NOTE The source launch conditions are described at the output of the launch cord. It is understood that the source, as supplied, has been verified by the test equipment manufacturer to produce the specified launch using a test cord with certain specifications. In the event that the launch cord needs to be replaced, obtain one that is compatible with the recommendation of the test equipment supplier or verify it by one of the procedures in Clause F.2.

The variable,  $X$ , is a tolerance threshold that varies with fibre core size and wavelength according to the values in Table E.1.

**Table E.1 – Threshold tolerance**

Threshold dB	Wavelength nm	
Fibre nominal core diameter ( $\mu\text{m}$ )	850	1 300
50	0,08	0,12
62,5	0,10	0,15

Table E.1 is referenced to nominal core diameter. The core diameter of the fibre in the actual launch cord is critical to good performance. A tolerance of better than  $\pm 1,0 \mu\text{m}$ , i.e.,  $\pm 0,7 \mu\text{m}$  is recommended.

An example of the encircled flux template for 50  $\mu\text{m}$  fibre at 850 nm is shown in Figure E.1. The target EF along with the EF that would be obtained by an overfilled launch are also shown.

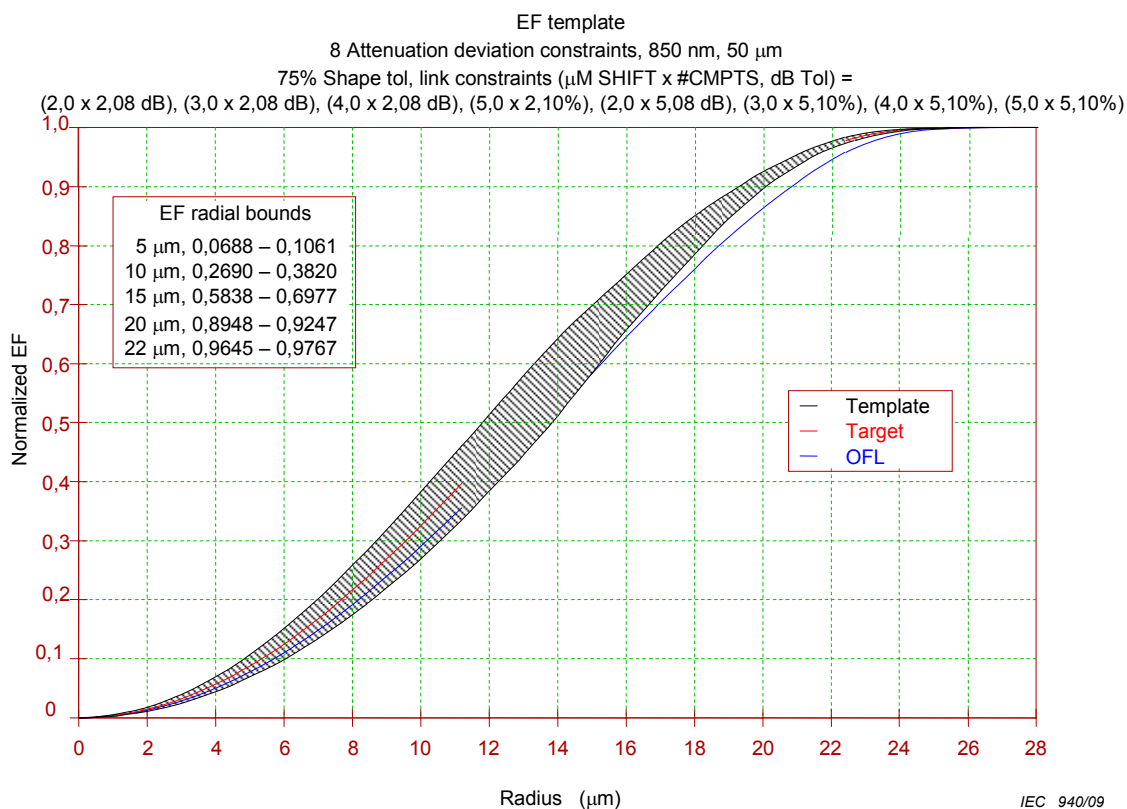
**Figure E.1 – Encircled flux template example**

The EF requirements are defined as a table of limiting values for each of a set of particular radial values for each combination of fibre size and wavelength. These limiting values are given in Tables E.2 through E.5.



**Table E.2 – EF requirements for 50 µm core fibre cabling at 850 nm**

Radius µm	EF lower bound	Target	EF upper bound
10	0,278 5	0,335 0	0,391 5
15	0,598 0	0,655 0	0,711 9
20	0,910 5	0,919 3	0,929 5
22	0,969 0	0,975 1	0,981 2

**Table E.3 – EF requirements for 50 µm core fibre cabling at 1 300 nm**

Radius µm	EF lower bound	Target	EF upper bound
10	0,279 2	0,336 6	0,394 0
15	0,599 6	0,656 7	0,713 8
20	0,907 2	0,918 6	0,930 0
22	0,966 3	0,972 8	0,979 3

**Table E.4 – EF requirements for 62,5 µm core fibre cabling at 850 nm**

Radius µm	EF lower bound	Target	EF upper bound
10	0,168 3	0,210 9	0,253 5
15	0,369 5	0,439 0	0,508 5
20	0,633 7	0,692 3	0,750 9
26	0,924 5	0,935 0	0,945 5
28	0,971 0	0,978 3	0,985 6

**Table E.5 – EF requirements for 62,5 µm core fibre cabling at 1 300 nm**

Radius µm	EF lower bound	Target	EF upper bound
10	0,168 0	0,211 9	0,255 8
15	0,369 9	0,440 9	0,511 9
20	0,636 9	0,694 5	0,752 1
26	0,925 4	0,935 7	0,946 0
28	0,970 8	0,978 2	0,985 6

## Annex F (informative)

### Measurement uncertainty examples

#### F.1 Uncertainties associated with using a reference grade termination

Reference grade connectors are used, where possible, to reduce measurement uncertainty. If a connector with an off-centre optical fibre were to be used, the results would vary depending on the particular orientation of the launch cord connector to the orientation of the offset of the connector in the cabling.

The interpretation of the measured loss of the cabling is likely to be based upon comparison with a specified acceptance figure to provide a pass/fail result. This acceptance figure may be based on a total loss figure for the cabling or it may be based on addition of the attenuation contributions of the individual components.

The use of reference grade terminations on the test leads means that the measured loss of the cabling will typically be less than if standard grade terminations are used. This may mean that if the acceptance figure is based upon the assumption of standard grade terminations for the finally configured system, for example, then some adjustment of the acceptance figure is necessary.

The following table shows examples of losses between the different possible combinations of reference and standard grade terminations.

**Table F.1 – Expected loss for examples (Note 1)**

Termination 1	Termination 2	Attenuation requirement
MM Reference grade	MM reference grade	≤ 0,1 dB
MM Reference grade	MM standard grade	≤ 0,3 dB
MM standard grade	MM standard grade	≤ 0,5 dB (note 2)
<p>NOTE 1 Table F.1 shows the required performance of standard and reference grade terminations in accordance with IEC 60874-19-1. These values are found in other, but not all, performance standards for connecting hardware.</p> <p>NOTE 2 97 % of individual connections are required meet this attenuation limit. As a minimum of two connections are present within installed cabling, a value of 0,5dB is quoted on a statistical basis.</p>		

#### *Example 1 (for one-cord reference)*

A multimode cabling system 100 m long is terminated in a patch panel at each end. The expected loss, assuming standard grade connectors, would be a total of up to 1,35 dB, assuming 3,5 dB/km cabled optical fibre loss and 0,5 dB per connection.

If this system is measured using the one test cord reference method as described, and using reference grade terminations on the test leads, then the loss will be up to 0,95 dB (0,35 dB for the 100 m of optical fibre plus 0,3 dB for each connection between reference grade and standard grade terminations).

For each reference grade to standard grade connection, i.e. in the measurement configuration, an adjustment of 0,2 dB should be subtracted from the acceptance figure.

#### *Example 2 (for three cord reference)*

Consider the above cabling system but with equipment connection cords with standard grade terminations connected into the patch panels. The loss excluding the terminal connectors will be the same as in example 1, i.e. 1,35 dB.

If this is tested as a cabling system terminated with connector plugs using the three-test-cord reference method, then the measured loss will 1,75 dB. This assumes 1,35 dB for the cabling as before, plus  $2 \times 0,2$  dB, since two reference-grade-to-reference-grade connections were included in the reference measurement, which are replaced by two reference-grade-to-standard grade connections in the measured power level through the cabling.

For each reference-grade-to-reference-grade connection in the reference measurement that is replaced by a reference-grade-to-standard grade connection in the measurement configuration, an adjustment of 0,2 dB should be added to the acceptance figure.

*Example 3 (Two cord reference, Figure C.3)*

The above cabling system is considered, but with connection cords with standard grade plug/socket style connectors, such as MTRJs, connected into patch panels. To test these systems, it is necessary to use the two-cord reference method with the addition of a reference grade adapter cord to complete the test configuration. This adapter cord allows connectivity but also adds the loss of the mated pair of connectors factored out in the referencing procedure because all the connectors involved are reference grade. However, the reference grade connector interface with the standard grade patch panel connectors will typically have a lower loss than those of the equipment patch cords. The acceptance criteria, therefore, needs to be reduced by  $2 \times 0,2$  dB = 0,4 dB.

## **F.2 Launch cord output near field verification**

### **F.2.1 Direct verification**

In this approach, the output of the launching cord is measured directly. A main uncertainty with respect to attenuation measurements associated with a conforming launch is with respect to the core diameter of the optical fibre in the launch cord.

When an optical fibre with core diameter that is larger than nominal is used, and the target launch is achieved, the attenuation results will be less than if an optical fibre on nominal were used.

When an optical fibre with core diameter that is smaller than the nominal is used, and the target launch is achieved, the attenuation results will be larger than if an optical fibre on nominal were used.

### **F.2.2 Test equipment manufacturer verification**

For the LSPM methods, the test equipment will generally include a light source with a socket into which the plug of a launching cord is inserted. The launching cord could be essentially straight with no auxiliary mode conditioners or it could include a fixed mode conditioner such as a mandrel or other device. The encircled flux emitted by the launching cord depends on the characteristic of the light source emerging from the face of the socket, the connection of the launching cord to the socket, the optical fibre within the launch cord, and any applied mode conditioning.

The test equipment manufacturer should provide specifications for the test cord that are compatible with the particular source implementation used. When the specification on the cord is met and used with the test equipment, the EF requirements should be assured.

## F.2.3 Field check with physical artefact

### F.2.3.1 General

The technicians making field measurements may not have access to the near field measurement equipment needed to confirm the requirements of Annex E. Even if the test equipment has been qualified by the manufacturer, there could be variations in the launching cord used or some other changed variables. This clause outlines a procedure that can provide a reasonable field check measurement. In the field, the procedure is based on attenuation measurements of physical artefacts. An artefact supplier has characterized the attenuation of these artefacts using launch conditions qualified by encircled flux measurements.

The intent of field attenuation measurements of the artefacts is to provide a check which could provide a reasonable confirmation that the measurements of the cabling should be satisfactory. The suitability of this approach, taking all variables into account, remains a point of study.

The rest of this clause provides guidance on the construction of an artefact that has been verified experimentally. Other solutions could exist.

The encircled flux limits are based on simulations of either two or five concatenations of different magnitude fixed offset connections. These provide boundaries that emphasize a need to control the outer radius encircled flux variations most tightly. This is due to the fact that the offset connections found in the cabling produce differential modal attenuation with the largest attenuation in the higher mode groups, which contribute most significantly to the higher radius part of the encircled flux. Variations in the launch power of these higher mode groups yield the largest variations in the measured attenuation of the cabling. Therefore a physical artefact must probe the higher mode groups that are emitted from the launching cord.

One way to do this is to construct some test cords with reference grade terminations at the ends and with a series of offset splices between the ends. This is illustrated in Figures F.1 to F.4.

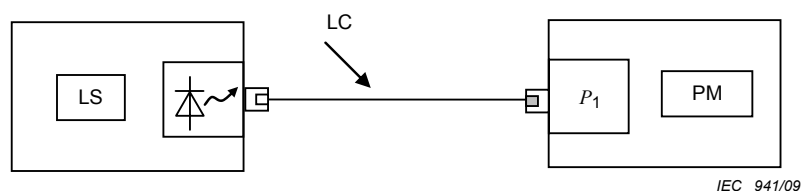

#### Key

LS	light source
LC	launch cord
PM	power meter

**Figure F.1 – Initial power measurement**

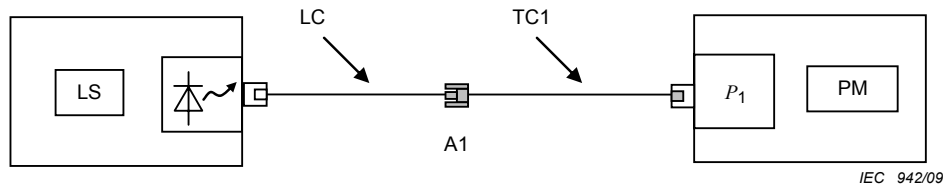

**Key**

LS	light source	TC1	test cord
LC	launch cord	PM	power meter
A1	connector set		

**Figure F.2 – Verification of reference grade connection**

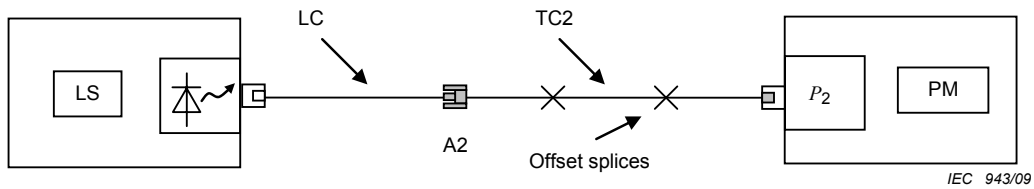

**Key**

LS	light source	TC2	test cord
LC	launch cord	X	offset splices
A2	connector set	PM	power meter

**Figure F.3 – Two offset splices**

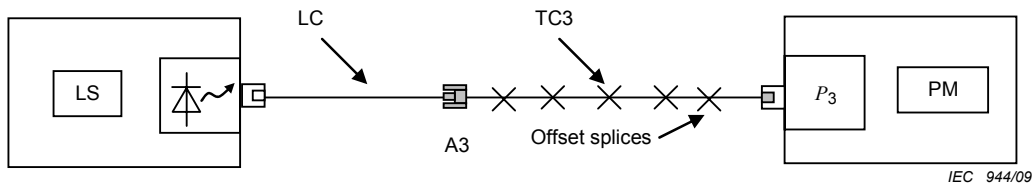

**Key**

LS	light source	TC3	test cord
LC	launch cord	X	offset splices
A3	connector set	PM	power meter

**Figure F.4 – Five offset splices**

**F.2.3.2 Procedure for attenuation characterization of artefacts**

The following procedure applies:

- Using a mode conditioner on the LC and EF measurements, bring the EF onto the target.
- Attach the LC to the PM as in Figure F.1 and measure  $P_0$  (all power measurements are dBm).
- Attach TC1 to the LC and PM as in Figure F.2 and measure  $P_1$ .

- Calculate  $L_1 = P_0 - P_1$ .
- Verify that  $L_1 \leq 0,1$  dB.
- Remove TC1 and attach TC2 as in Figure F.3 and measure  $P_2$ .
- Calculate  $L_2 = P_0 - P_2$  and  $L_{2ADJ} = L_2 - L_1$ .
- Remove TC2 and attach TC3 as in Figure F.4 and measure  $P_3$ .
- Calculate  $L_3 = P_0 - P_3$  and  $L_{3ADJ} = L_3 - L_1$ .

$L_{2ADJ}$  and  $L_{3ADJ}$  are the target attenuations for TC2 and TC3.

Repeat the procedure after adjusting the EF to the maximum and minimum template values, to produce the attenuation extremes for the two test cords.

### F.2.3.3 Construction details

The EF is specified at a number of control radius values with a target, upper limit, and lower limit, which can be viewed as target and tolerances. The measured value can be converted into a normalized metric which gives the percent of total tolerance used (PTU). The sign of this metric is normally made to be positive for overfilling compared to target and negative for underfilling. Overfilling compared to target occurs when the measured EF is less than the target.

In the procedure, there is a prescription to adjust the mode conditioner so the output EF is on target. For best results, this can be satisfied when PTU for the maximum control radius is within  $\pm 5\%$  and the others are within  $\pm 35\%$ . When the EF is adjusted to the maximum or minimum of the EF template, the maximum control radius EF value should be the primary concern. Hardly any launch can be made to touch the EF template boundaries at all control radii.

The optical fibre in the test cords should be on nominal for core diameter or just a little higher ( $<1\ \mu\text{m}$ ) than nominal. The length of optical fibre between splices or connectors should be between 2 m and 4 m. In the experimental results 3 m was used. The splices should have offsets between  $3\ \mu\text{m}$  and  $4\ \mu\text{m}$ , corresponding to individual connection losses between approximately 0,2 dB and 0,3 dB. In the experimental results, a splicer with a dial-in offset feature was used. The target offset was  $3,5\ \mu\text{m}$ .

All terminations must be reference grade.

### F.2.3.4 Example results

The following experimental results were obtained from  $50\ \mu\text{m}$  optical fibre at 850 nm.

Two LED based sources with spectral width approximately 35 nm full width at half maximum were used. Two different mode conditioning approaches were used to adjust the EF:

- mandrel – typically 25 mm and partial turns;
- mandrel plus mode conditioning device.

With the mandrel plus mode conditioning device, the maximum degree of allowed fill could not be achieved.

Figures F.5 to F.7 show the EF results in terms of percent tolerance used for the different control radii and the two devices at the EF middle, lower, and upper limits.

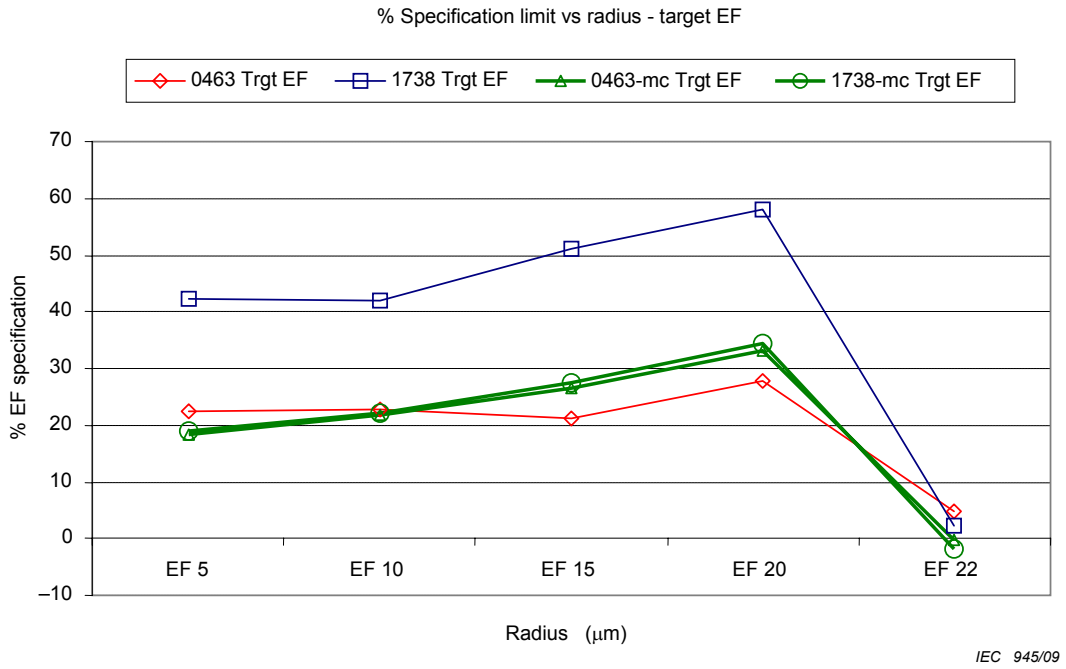

Figure F.5 – EF centred

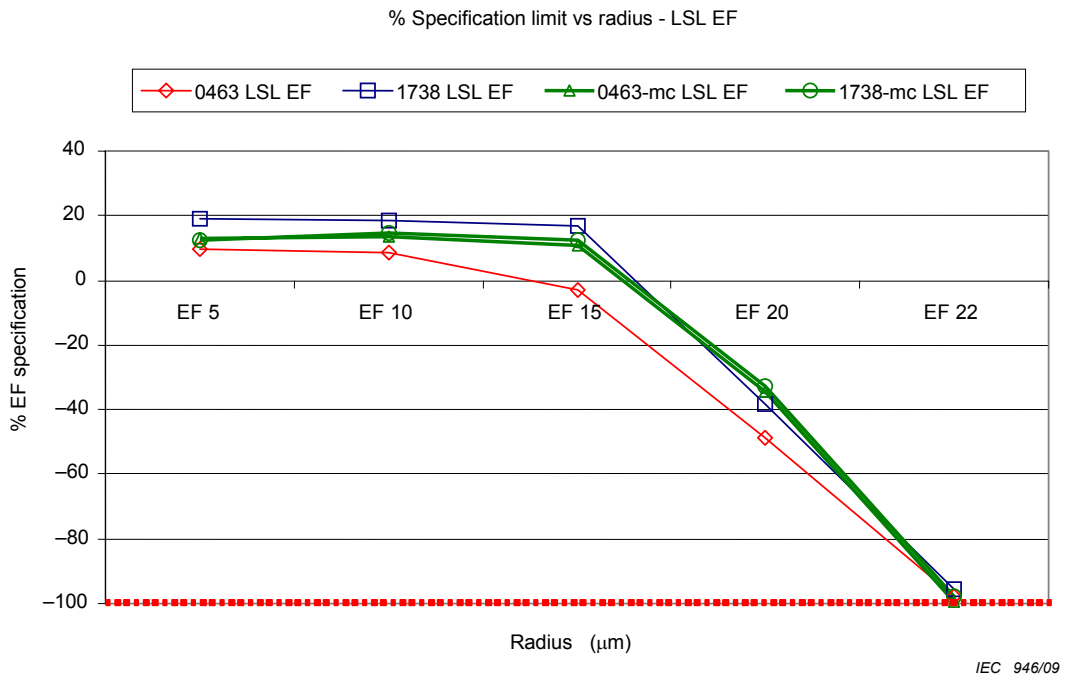
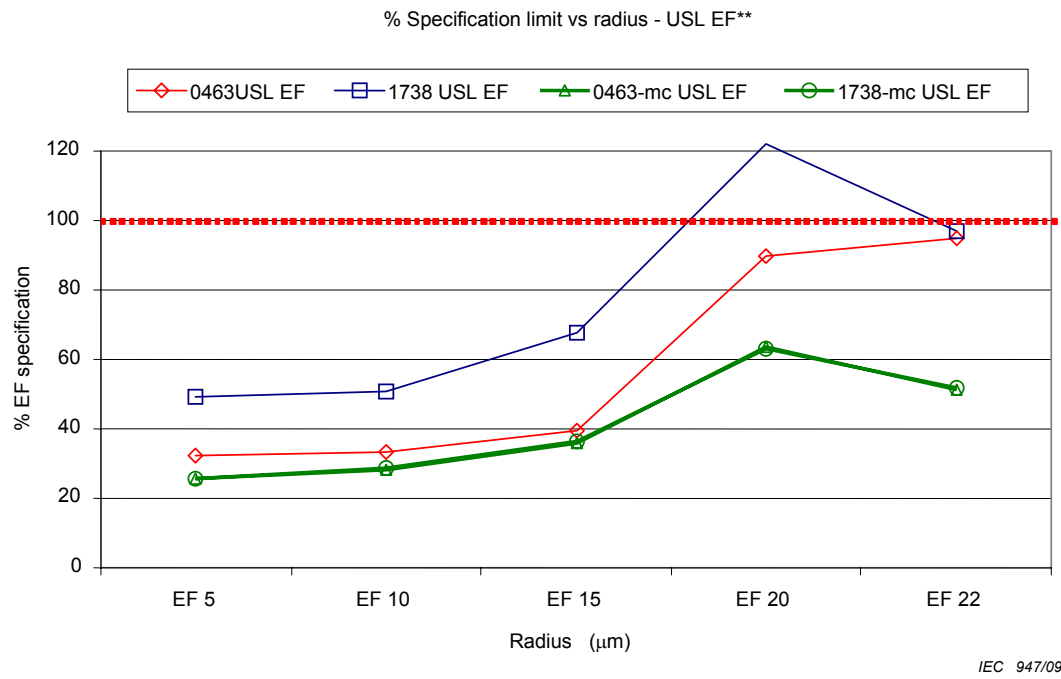
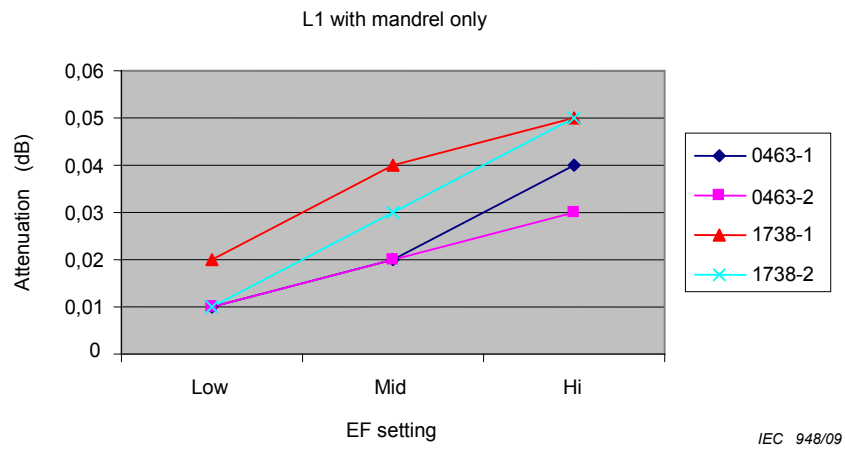

Figure F.6 – EF underfilling



**Figure F.7 – EF overfilling**

The next series of figures shows the attenuation measurement results with two replicates for each source for these conditions.



**Figure F.8 – L1 loss with mandrel**



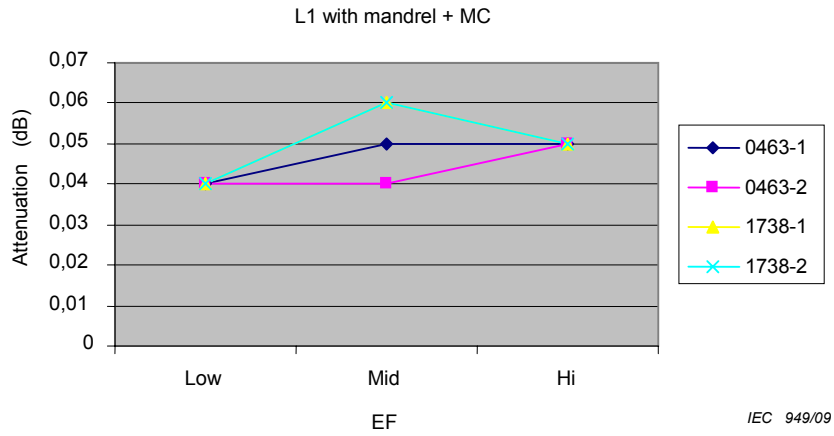

Figure F.9 – L1 loss with mandrel and mode conditioner

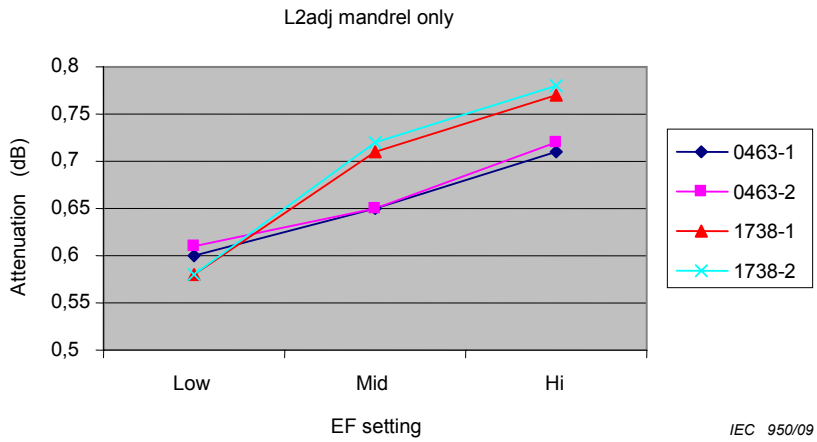

Figure F.10 – L2 loss (adjusted) with mandrel

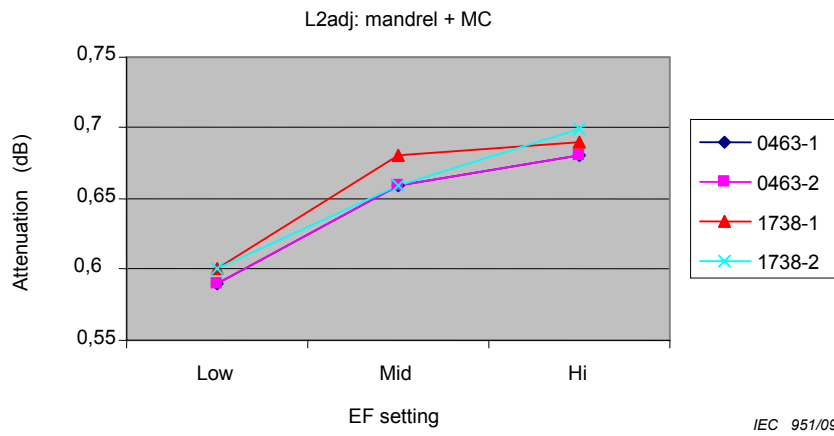
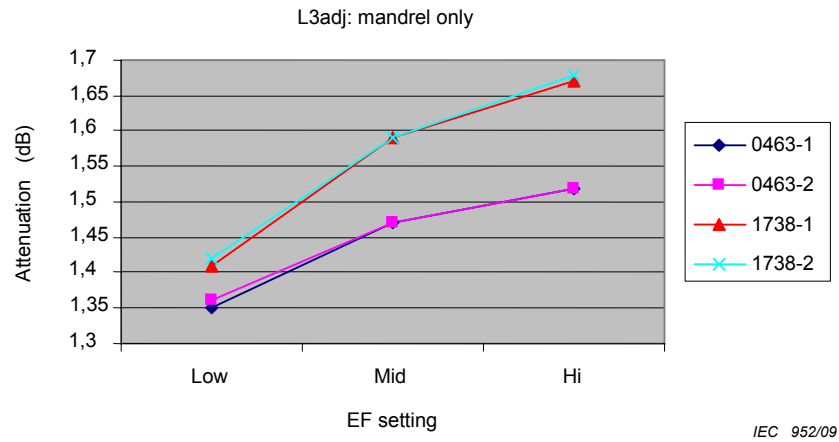
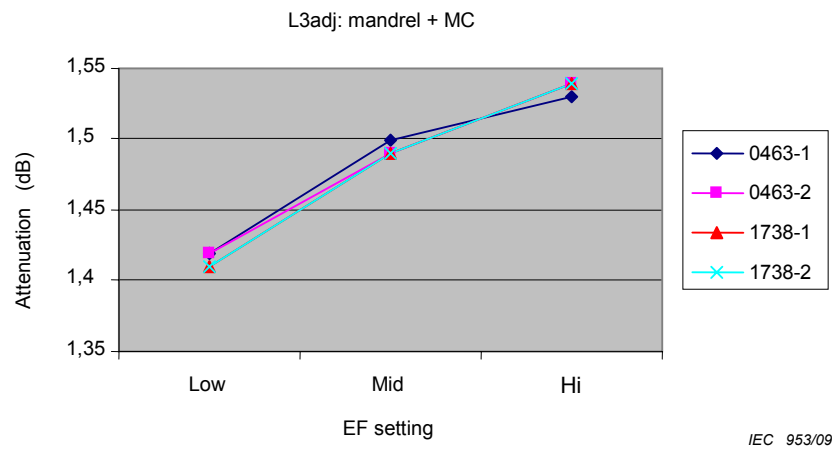

Figure F.11 – L2 loss (adjusted) with mandrel and mode conditioning



**Figure F.12 – L3 loss (adjusted) with mandrel**



**Figure F.13 – L3 loss (adjusted) with mandrel and mode conditioning**

Device 1738, which was slightly overfilling without the mode conditioning device at the 20  $\mu\text{m}$  control radius values and lower, had relatively higher attenuation measurement results. This illustrates the need to minimize the deviation from the EF target across all the control radii when artefact targets and limits are produced.

The variance in attenuation values remains within approximately  $\pm 10\%$  as the degree of fill is varied across the template.

## **Annex G** (informative)

### **OTDR configuration information**

#### **G.1 Introduction**

Annex G provides information regarding OTDRs and their configuration. It also provides additional diagrams to help in the application of Annex D. Refer to IEC 61746.

The OTDR operates by injecting a short pulse of light into one end of the fibre optic system under test and monitoring as a function of time delay the returning signal coming back out of the same end of the optical fibre.

This returning signal comes from two sources:

- 1) scattered light from within the optical fibre itself. This is due to Rayleigh scattering caused by minute variations in the molecular structure of the silica causing some of the light pulse's energy to be scattered in all directions – a very small proportion of this is scattered back in the direction it came from – this is known as 'backscatter'.
- 2) reflections from interfaces and changes in refractive index at discrete points along the length of the system. These are known as Fresnel reflections.

The graph of returning signal power as a function of time delay is the raw data that the OTDR has to work with. Usually this raw data is processed by the OTDR such that the returning signal power is plotted on a logarithmic scale to give loss in decibels on the vertical scale. On the horizontal scale, the time delay for the round trip is converted into a one-way distance along the system, by providing the OTDR with a figure for the group index (effective refractive index) of the optical fibre under test.

This resultant graph of loss on the vertical scale against distance on the horizontal scale is known as a backscatter trace. Analysis of this backscatter trace can yield much information about the cabling under test including:

- total attenuation of the link or channel under test;
- total optical return loss of the link or channel under test, see IEC 61300-3-6;
- length (and propagation delay) of the link or channel under test;
- attenuation coefficient of the optical fibre in the cabling under test;
- attenuation of connections (splices and connector pairs);
- return loss (reflectance) of reflective features such as connector pairs and mechanical splices;
- distance information between features on the trace.

However, successful and comprehensive characterization of the cabling under test is dependent upon a number of factors including:

- the optical performance of the OTDR being used;
- the correct set up of the OTDR's measurement parameters;
- the correct measurement configuration including appropriate length launch leads and tail leads;
- measurement good practices – cleanliness of connectors etc.;
- the use of bidirectional measurement (see Clause G.6).

## **G.2 Fundamental parameters that define the operational capability of an OTDR**

### **G.2.1 Dynamic range**

The capability of an OTDR to measure a large amount of attenuation. The dynamic range is the difference between the maximum backscatter level near 0 m and the noise floor. The dynamic range increases when the laser pulse width increases, and when the noise level decreases by averaging.

See IEC 61746 for a formal definition of dynamic range.

### **G.2.2 Pulse width**

The pulse width and laser peak power define the energy level launched into the optical fibre. This determines the amount of scattering signal returning. As pulse width increases, dynamic range increases, however, dead zones increase.

### **G.2.3 Averaging time**

The averaging time defines the duration to sum and average a large number of data samples. Best signal characterization is preferable yet takes the longest averaging time. The greatest benefit to averaging time occurs during the first 30 s of averaging. Generally, a dynamic range increase of 0,75 dB occurs when doubling the number of averages.

### **G.2.4 Dead zone**

There are several orders of magnitude difference between the very small signal level received from the backscattered light within the optical fibre and the relatively large signal level received from Fresnel reflections at reflective interfaces at connectors. It takes a finite time for the detector in the OTDR to recover from the Fresnel reflection such that it can measure the backscattered light levels again. During this time it is not possible for the OTDR to measure any variation in the backscattered signal level (such as splice losses for example) and so the section of optical fibre following a reflection is referred to as the 'dead zone'.

The length of this dead zone will depend upon the response time of the detector, the magnitude of the Fresnel reflection and its duration, which is determined by the pulse width.

For multimode applications the most significant dead zone is the attenuation dead zone. This is the distance after a reflective event at which the backscatter level has become linear and loss measurements can be made. Refer to IEC 61746 for a full definition of the attenuation dead zone.

## **G.3 Other parameters**

### **G.3.1 Index of refraction**

The index of refraction is used to set up the scale factor of the horizontal scale. This allows fault location and attenuation coefficient calculation.

On a general basis the index of refraction is not known, while the length of the optical fibre is known. In this case the real index of refraction can be determined.

When the index of refraction is known it shall be used; otherwise use the values of Table G.1.

**Table G.1 – Default effective group index of refraction values**

Centre wavelength	850 nm	1 300 nm
MMF (50/125 $\mu$ m)	1,483 5	1,478 5
MMF (62.5/125 $\mu$ m)	1,496 0	1,491 0

**G.3.2 Measurement range**

The measurement range or measurement span is the distance that is covered by the OTDR time base. The measurement range shall be set to be greater than the length of the optical fibre to be tested. Note that on some OTDRs, when testing systems with strongly reflective connectors, it may be desirable to set the measurement range to be greater than twice the length of the system under test in order to reduce ghosting effects.

**G.3.3 Distance sampling**

The distance sampling (or sampling resolution) is the distance between two points of the horizontal scale. This distance may be coupled to the measurement range (e.g. the number of data points is a constant).

When adjustable, the sampling resolution should be set to a small enough interval to ensure that all features of the link are well resolved. In any case, ten times lower than the pulse width. Note that the size of the data file generated will be proportional to the measurement range divided by the sampling resolution.

**G.4 Other measurement configurations****G.4.1 General**

This clause reports some particular measurement configurations that are not part of Annex D.

**G.4.2 Macro bend attenuation measurement**

Figure G.1 illustrates the proper measurement trace of a macro bend within a cabling. The attenuation of a macro bend is measured using linear regressions on both sides of the macro bend. The attenuation is given by the difference of displayed power level at the intercept of the two linear regressions with the vertical axis of the bending location. Note that the bending location is before the change of curvature of the trace.

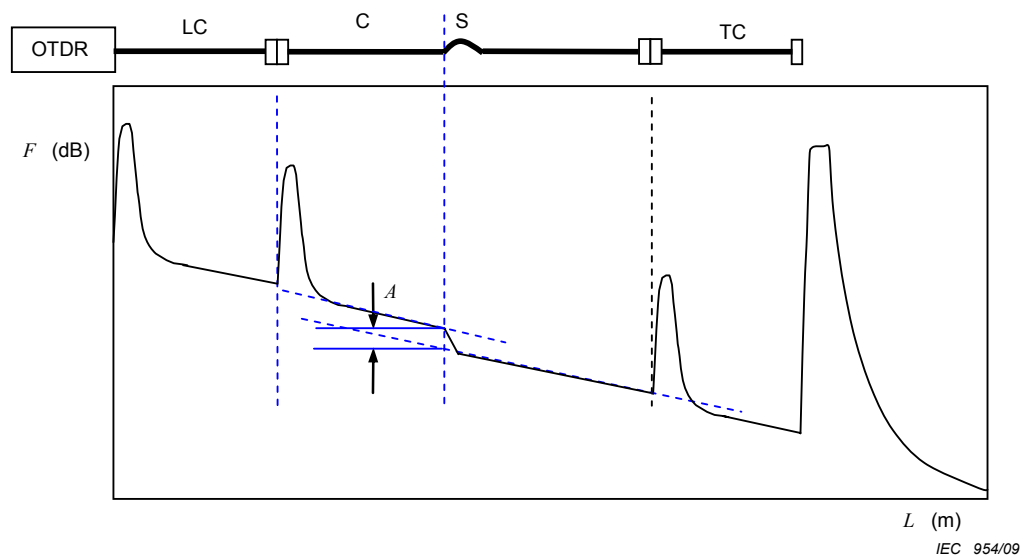
**Key**

OTDR	optical time domain reflectometer	$F$	reflected power level
LC	launch cord	$L$	distance from OTDR output port
C	cabling under test	$A$	splice attenuation
TC	test cord		

**Figure G.1 – Splice and macro bend attenuation measurement****G.4.3 Splice attenuation measurement**

Use the same process as previously defined for a macro bend within a cabling.

**G.4.4 Measurement with high reflection connectors or short length cabling**

Figure G.2 illustrates a measurement of installed cabling with highly reflective connectors. The strong reflection at the launch cable causes pulse clipping and tailing. Tailing makes attenuation coefficients difficult to measure.

This demonstrates how it is important to follow the measurement procedure that does not use any part of the tailing signal.

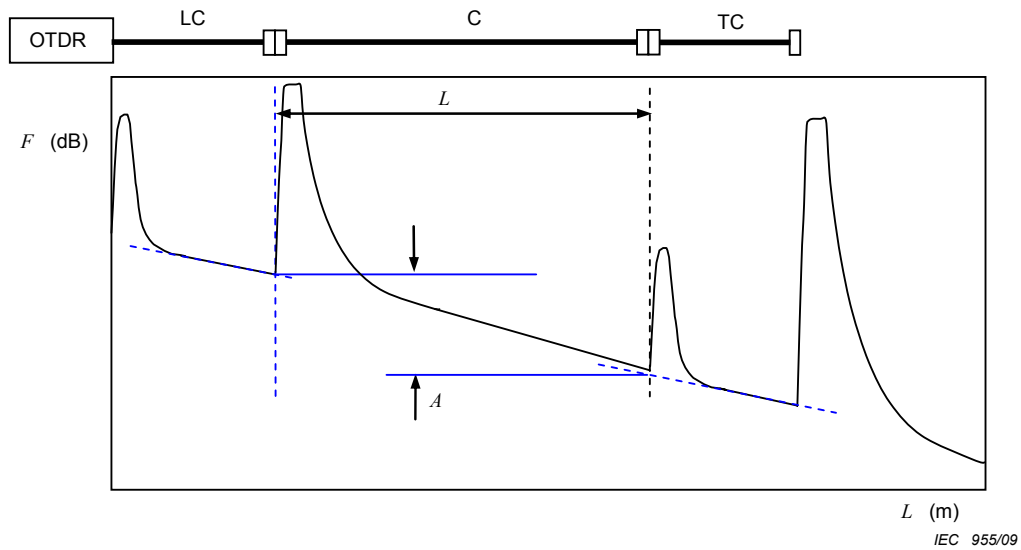

**Key**

OTDR	optical time domain reflectometer	$F$	reflected power level
LC	launch cord	$L$	length of cabling under test
C	cabling under test	$A$	attenuation
TC	test cord		

**Figure G.2 – Attenuation measurement with high reflection connectors**

Figure G.3 illustrates a measurement of a short length cabling. The length of the link is shorter than the attenuation dead zone. Separate measurements of the cabling and connections are not available (see D.3.4), while the overall measurement is still available.

This demonstrates again how it is important to follow the measurement procedure that does not use any part of the tailing signal.

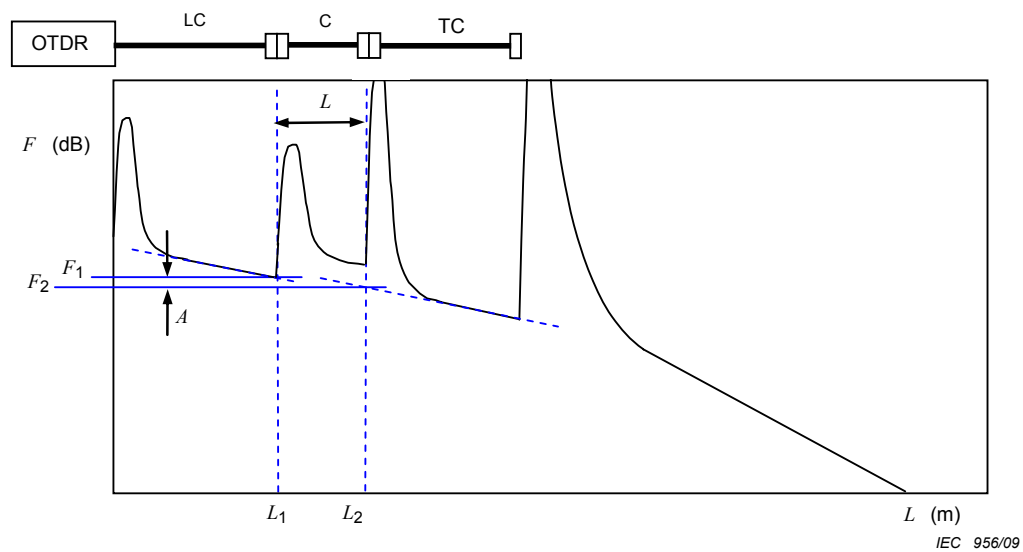
**Key**

OTDR	optical time domain reflectometer	$F$	reflected power level
LC	launch cord	$L$	length of cabling under test
C	cabling under test	$A$	attenuation
TC	test cord		

**Figure G.3 – Attenuation measurement of a short length cabling**

#### G.4.5 Ghost

Figure G.4 illustrates a measurement of installed cabling with a highly reflective connector and resulting ghost. The OTDR software may identify ghosts properly; if not, ghost can be identified when the distance between two events on the optical fibre is duplicated.



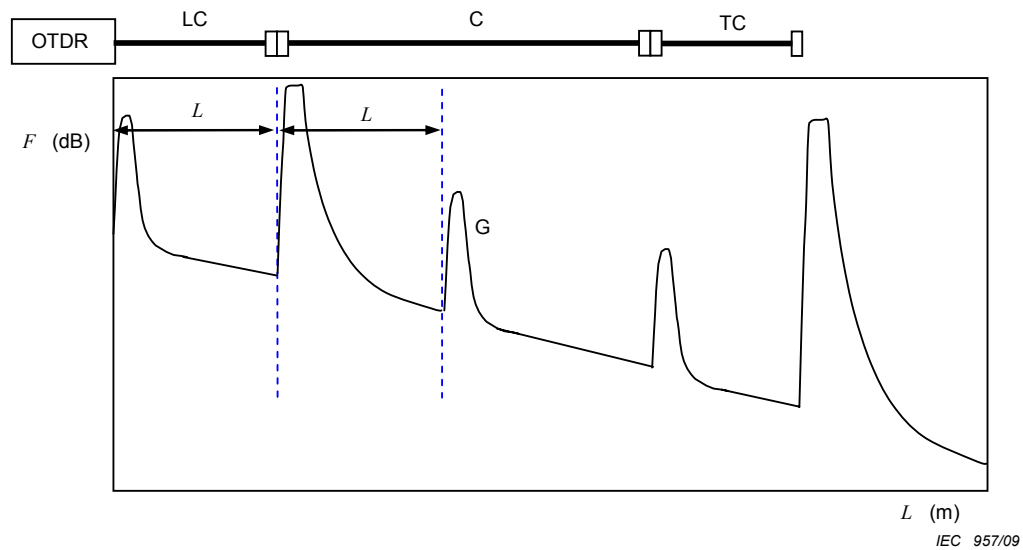

**Key**

OTDR	optical time domain reflectometer	<i>F</i>	reflected power level
LC	launch cord	<i>L</i>	length of the launching cord (duplicated)
C	cabling under test	G	ghost reflection
TC	test cord		

**Figure G.4 – OTDR trace with ghost**

**G.5 More on the measurement method**

The measurement method defined in Annex D is also called the five cursors method. This is due to the fact that readings at five cursors positions are used to complete the measurement.

Figure G.5 shows cursors positioning on the backscattering trace. C1 and C2 define the area of linear regression the launching test cable. C3 and C4 define the area of linear regression the tail test cable. C5 needs to be placed at *L*1.

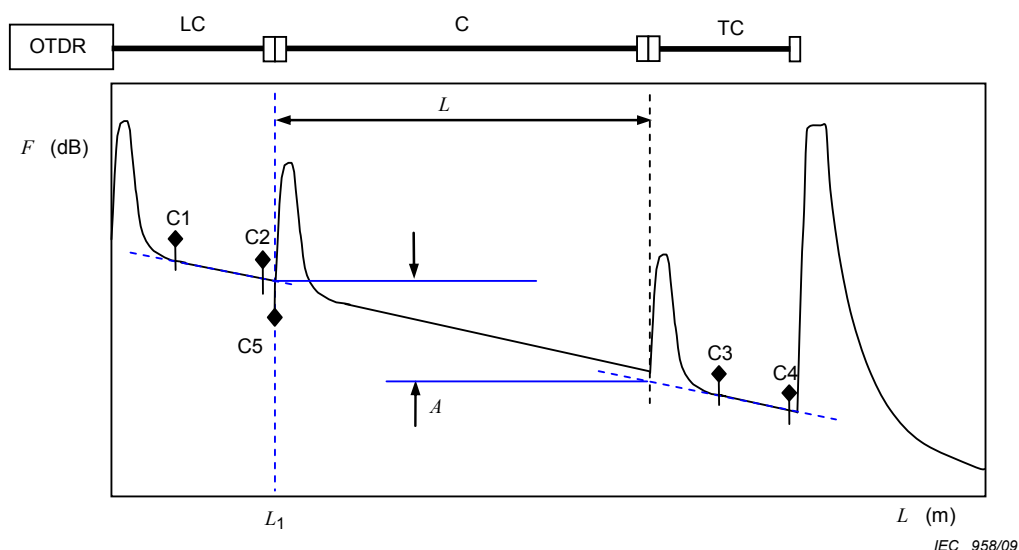
**Key**

OTDR	optical time domain reflectometer	C1, C2, C3, C4	cursors for linear regression definition
LC	launch cord	$L$	length of cabling under test
C	cabling under test	$A$	attenuation
TC	test cord	$L_1$	distance to cabling under test

**Figure G.5 – Cursors positioning**

Make sure that the OTDR is configured for the application of a linear regression between the cursors. This configuration may also be called least square approximation (LSA).

NOTE The alternative of the linear regression setting (LSA) is generally called two points. This configuration generally leads to significant errors as the calculation of the slope is made using only two points of the backscattering trace while the LSA reduce the consequence of the noise and nonlinear response due to dead zone effects.

**G.6 Bidirectional measurement**

For cabling containing splices or additional connectors, OTDR testing can be carried out from both ends of the cabling under test. This allows any inaccuracy in the measurement of component attenuation due to variations in the optical fibre backscattering characteristics to be cancelled out by averaging the component attenuation measurements taken from both ends of the system.

Bi-directional testing is required if the fibre characteristics of the test cords differ from those of the cable under test. If the launch cord and tail cord have identical scattering characteristics and it is only the total insertion loss of the link that is required to be measured, then it is sufficient to carry out OTDR testing in one direction only. However, if the launch cord and tail cord have different characteristics from each other or if it is required to measure accurately the insertion loss of individual connector interfaces or other events in the cabling then bi-directional OTDR testing is required.

In order to properly measure the first and last connection for bi-directional averaging, one must keep the launch and tail cords in their initial measurement positions. Thus, the launch cord of the first direction becomes the tail cord of the opposite direction. This will ensure that identical optical fibres are mated so that the effects of mode field mismatch between the test cords and cabling can be averaged out.

An individual attenuation is defined as the half sum of the attenuation recorded from each end.

$$A = \frac{A_{oe} + A_{eo}}{2} \text{ (dB)} \quad (\text{G.1})$$

where  $A_{oe}$  is the attenuation measured in the direction from the origin to the extremity and  $A_{eo}$  is the attenuation measured in the direction from the extremity to the origin.

See also IEC/TR 62316 for more details.

NOTE Some OTDR may include specific firmware to manage bidirectional measurement.

## **G.7 Non recommended practices**

### **G.7.1 Measurement without tail test cord**

If the tail test cord is missing, the attenuation of the connector at the end of the cabling is not taken into account. Also the measurement is not possible when the length of the cabling is short regarding the attenuation dead zone (see G.4.4).

This type of measurement is only acceptable for the qualification of a repair of cabling that had been tested before the damage (assuming configurations of the OTDR and the cabling allow the visualization of the repair).

### **G.7.2 Cursor measurement**

OTDR generally provides an easy access to two cursors showing location and power level position as well as the attenuation between the two cursors.

The use of such function is not recommended for qualification because the LSA function is not used and because the measurement location may not be correct.

However such functionality can be useful in an optimization process.

## **Annex H** (informative)

### **Test cord insertion loss verification**

#### **H.1 Introduction**

The validity of installed cabling loss measurements critically depends on the insertion loss performance of the test cords used in all LSPM methods. Test cord insertion loss verification should be performed before formal testing of installed cabling begins. Cords should be re-verified at the beginning of each testing session, for example on a daily basis, or after the number of plug insertions approach the stated mating durability specification, typically defined in hundreds of cycles.

Test cord insertion loss performance verification involves measuring the loss of the test cords, and possibly performing steps to obtain acceptably low insertion loss performance, prior to measuring the installed cabling. The maximum acceptable loss may be established in a number of ways, for example, by customer testing requirements, the specifications claimed by the manufacturer of the test cords or by cabling standards. It is not advisable to set acceptance criteria for test cords to levels as high as the minimum performance level (i.e. maximum allowable connection loss) permitted by cabling standards, as the magnitude of this allowance, typically up to 0,75 dB, contributes directly to uncertainty of the measured cabling loss.

The launch cord affects the launch condition. The recommended verification sequence is to first choose a launch cord that is expected to be in good condition and previously confirmed to produce the required launch condition, including any necessary mode conditioning devices, when used with the specific light source intended for installed cabling tests. Should poor launch cord loss performance necessitate its replacement, first establish the launch conditioning required, if any, for the replacement launch cord using the procedures of Annex F, then return to this annex to verify insertion loss performance.

#### **H.2 Apparatus**

The light source, power meter and test cords defined in the main text are required. The launch cords should contain any mode conditioning elements required to bring the launch condition into compliance.

It is necessary to use a power meter that will mate to the plugs of the test cords, that is, offer a socket or adapter of the same type as that of the installed cabling to be tested. This may be accomplished two ways:

- 1) by using a compatible socket on the power meter, or
- 2) by attaching to the power meter a short (<2 m) “bucket cord”, free of bends of radius less than 30 mm, having a cable-plant-compatible adapter on one end and a plug compatible with the power meter socket on the other. The optical fibre within the bucket cord is of a larger core diameter and higher numerical aperture than that of the cords under test so that substantially all light may be collected from the cords under test. When verifying test cords containing type A1a 50/125µm optical fibre, a bucket cord containing type A1b 62,5/125µm optical fibre or type A1d 100/140µm optical fibre can be used; when verifying test cords containing type A1b 62,5/125µm optical fibre, a bucket cord containing type A1d 100/140µm optical fibre can be used.

### H.3 Procedure

#### H.3.1 General

The verification procedure depends on the number and type of cords used in the test method. A power meter with a compatible socket is illustrated. The bucket cord adaptation is not shown.

The procedures are presented in the following organization and order:

- One-cord and two-cord methods
  - use H.3.1 for test cord interfaces that are non-pinned/unpinned and non-plug/socket connector styles such as LC, SC or other plug/adaptor/plug types;
  - use H.3.2 for test cord interfaces that are of the pinned/unpinned style such as the MT-RJ, or are of the plug/socket style such as the SG.
- Three-cord method
  - use H.3.3 for test cord interfaces that are non-pinned/unpinned and non-plug/socket connector styles such as LC, SC or other plug/adaptor/plug types;
  - use H.3.4 for test cord interfaces that are of the pinned/unpinned style such as the MT-RJ, or are of the plug/socket style such as the SG.

Most of the procedures contain optional sequences that are designed to test the cords bi-directionally. Regardless of whether these optional steps are performed, labelling of the cords is advised so that their orientation and order in the test cord sequence can be identified.

The loss formulas assume that power readings are made in absolute linear units such as microwatts ( $\mu\text{W}$ ) or milliwatts (mW) that must be converted to decibels using logarithms. If the power readings are made in relative logarithmic units such as decibels relative to a milliwatt (dBm), then the loss is determined by subtraction of the reading from the reference. For example, if the reference is  $-12$  dBm and the reading is  $-12,5$  dBm, the loss is  $(-12 \text{ dBm}) - (-12,5 \text{ dBm}) = 0,5 \text{ dB}$ .

In any of the procedures, should the connection between the launch cord TC1 and the light source be disturbed, for example by disconnection or mechanical stress, a new reference power level must be obtained because the amount of power coupled from the light source is typically sensitive to these disturbances.

#### H.3.2 Test cord verification for the one-cord and two-cord reference test methods when using non-pinned/unpinned and non-plug/socket style connectors

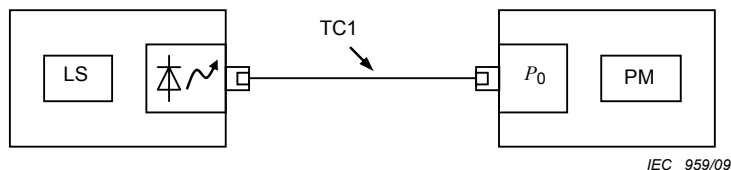

IEC 959/09

**Key**

- LS light source
- TC1 launch cord
- PM power meter

**Figure H.1 – Obtaining reference power level  $P_0$**

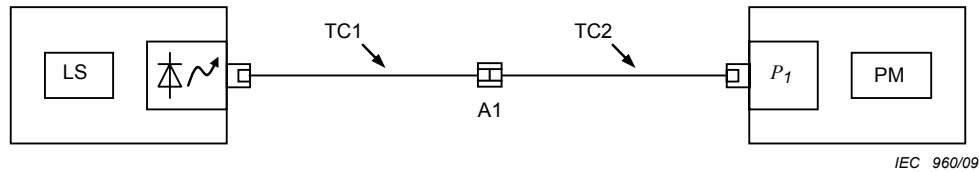
**Key**

LS	light source	TC2	test cord
TC1	launch cord	PM	power meter
A1	connector set		

**Figure H.2 – Obtaining power level  $P_1$** 

- 1) Obtain reference power measurement  $P_0$  with launch cord TC1 as shown in Figure H.1.
- 2) Insert adapter A1 and receive cord TC2 between TC1 and power meter as shown in Figure H.2 and record  $P_1$ .
- 3) Determine the loss as  $10 \log(P_0/P_1)$  [dB]. Verify loss is within acceptable limits. If not, clean the plugs and adapter A1, or replace TC1, TC2 and A1 as necessary before continuing. After cleaning or replacement, repeat from step 1).

Steps 4), 5), and 6) are recommended but optional. If steps 4), 5), and 6) are not performed, then the cords must be used only in their tested orientation. More precisely, performing steps 4) and 5) allows TC2 to be used in either orientation; performing step 6) allows TC1 to be used in either orientation.

- 4) Disconnect TC2 from the power meter and adapter, interchange the ends, reinsert between adapter and power meter and record a second power level,  $P_2$ .
- 5) Determine the loss as  $10 \log(P_0/P_2)$  [dB]. Verify loss is within acceptable limits. If not, clean the plugs and adapter A1, or replace TC1, TC2 and A1 as necessary before continuing. After cleaning or replacement, repeat from step 1).
- 6) If the plugs of TC1 are of the same type on both ends, disconnect TC1 from the light source and adapter, interchange the ends, and repeat steps 1) through 5), obtaining a new reference reading  $P_3$  and power readings  $P_4$  and  $P_5$  as above.

### H.3.3 Test cord verification for the one-cord and two-cord reference test methods when using pinned/unpinned or plug/socket style connectors

This procedure is subdivided into two parts, one for compatible and another for incompatible interfaces. The procedure of H.3.2.1 applies to cases where TC1 and TC2 provide mutually compatible interfaces between them, where, for example, one plug is pinned and the other unpinned, or where one is a plug and the other a socket. The procedure of H.3.2.2 applies to cases where TC1 and TC2 do not provide mutually compatible interfaces between them, where, for example both plugs are pinned or unpinned, or both are plugs or sockets.

#### H.3.3.1 Compatible interfaces

This procedure differs from that of H.3.1 because the cords are assumed to be directional due to their pinning or plug/socket arrangements. In cases where this assumption does not apply, the procedures of H.3.1 are recommended so that bi-directional test cord verification can be established. Cases where bi-directional verification may be possible include power meters that can accept both pinned and unpinned plugs.

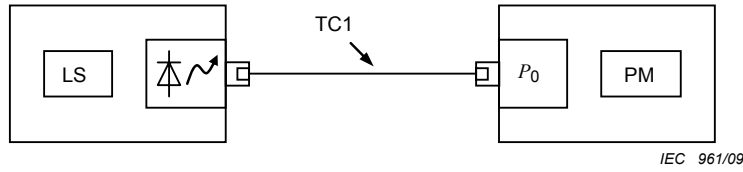

**Key**

- LS light source
- TC1 launch cord
- PM power meter

**Figure H.3 – Obtaining reference power level  $P_0$**

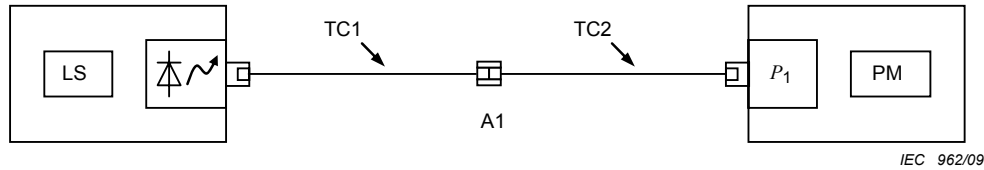

**Key**

- LS light source
- TC1 launch cord
- A1 connector set
- TC2 test cord
- PM power meter

**Figure H.4 – Obtaining power level  $P_1$**

- 1) Obtain reference power measurement  $P_0$  with launch cord TC1 as shown in Figure H.3.
- 2) Insert adapter A1 and receive cord TC2 between TC1 and power meter as shown in Figure H.4 and record  $P_1$ . A socket for plug/socket style connections replaces adapter A1.
- 3) Determine the loss as  $10 \log(P_0/P_1)$  [dB]. Verify loss is within acceptable limits. If not, clean the plugs and adapter A1 (or socket), or replace TC1, TC2 and A1 as necessary before continuing. After cleaning or replacement, repeat from step 1).

**H.3.3.2 Incompatible interfaces**

Particular configurations of pinned/unpinned and plug/socket style connections necessitate the introduction of a third cord that provides a compatible interface between the cords under test. The insertion loss of this three-cord combination must be sufficiently low so that the combined losses still pass the acceptance criteria for the loss of a single interface. Configurations that necessitate a third cord include those where TC1 and TC2 are both pinned or unpinned, or are both plugs or sockets in a plug/socket style arrangement.

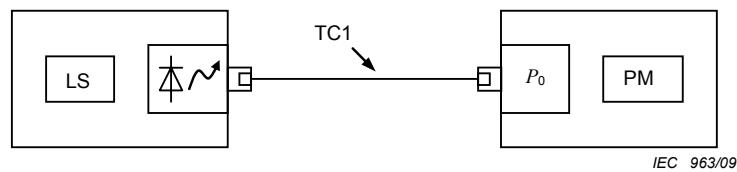
**Key**

LS	light source
TC1	launch cord
PM	power meter

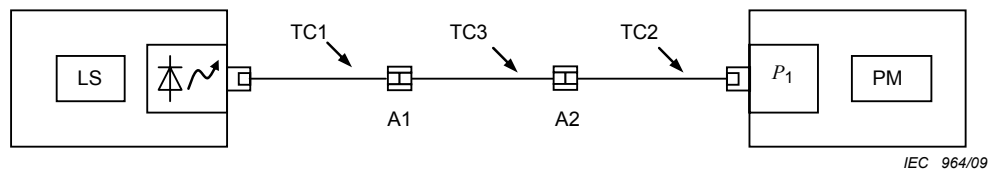
**Figure H.5 – Obtaining reference power level  $P_0$** **Key**

LS	light source	TC3	test cord
TC1	launch cord	TC2	receive cord
A1	connector set	PM	power meter
A2	connector set		

**Figure H.6 – Obtaining power level**

- 1) Obtain reference power measurement  $P_0$  with launch cord TC1 as shown in Figure H.5.
- 2) Insert adapters A1, A2, cord TC3, and receive cord TC2 between TC1 and power meter as shown in Figure H.6 and record  $P_1$ . For plug/socket styles, the adapters are replaced by sockets on the ends of TC3.
- 3) Determine the loss as  $10 \log(P_0/P_1)$  [dB]. Verify loss is within acceptable limits. If not, clean the plugs and adapters, or replace TC1, TC2, TC3 and adapters A1 and A2 as necessary before continuing. After cleaning or replacement, repeat from step 1).

Steps 4), 5), and 6) are recommended but optional. If steps 4), 5), and 6) are not performed, then the cords must be used only in their tested orientation. More precisely, performing steps 4) and 5) allows TC2 to be used in either orientation; performing step 6) allows TC1 to be used in either orientation.

- 4) In configurations that permit, disconnect TC2 from the power meter and adapter, interchange the ends, reinsert between adapter and power meter, and record a second power level,  $P_2$ .
- 5) Determine the loss as  $10 \log(P_0/P_2)$  [dB]. Verify loss is within acceptable limits. If not, clean the plugs and adapters, or replace TC2, TC3 and adapter A2 as necessary before continuing. After cleaning or replacement, repeat from step 1).
- 6) If the plugs of TC1 are of the same type on both ends, disconnect TC1 from the light source and adapter, interchange the ends, and repeat steps 1) through 3).



**H.3.4 Test cord verification for the three-cord reference test method when using non-pinned/unpinned and non-plug/socket style connectors**

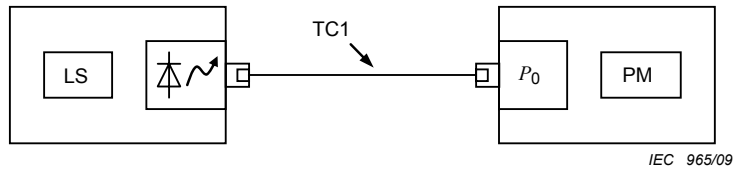

**Key**

- LS light source
- TC1 launch cord
- PM power meter

**Figure H.7 – Obtaining reference power level  $P_0$**

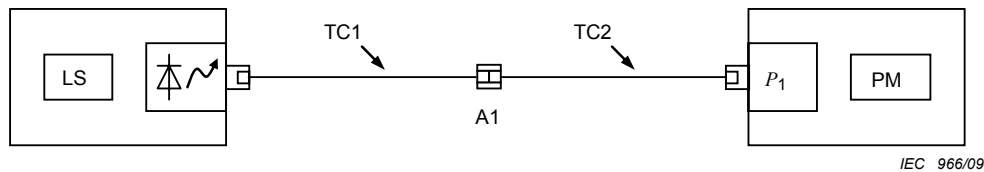

**Key**

- LS light source
- TC1 launch cord
- A1 connector set
- TC2 test cord
- PM power meter

**Figure H.8 – Obtaining power level  $P_1$**

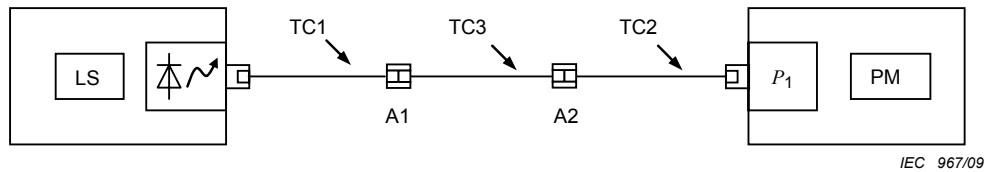

**Key**

- LS light source
- TC1 launch cord
- A1 connector set
- TC3 test cord
- A2 connector set
- TC2 receive cord
- PM power meter

**Figure H.9 – Obtaining power level  $P_5$**

- 1) Obtain reference power measurement  $P_0$  with launch cord TC1 as shown in Figure H.7.
- 2) Insert adapter A1 and receive cord TC2 between TC1 and power meter as shown in Figure H.8 and record  $P_1$ .
- 3) Determine the loss as  $10\log(P_0/P_1)$  [dB]. Verify loss is within acceptable limits. If not, clean the plugs and adapter A1, or replace TC1, TC2 and A1 as necessary before continuing. After cleaning or replacement, repeat from step 1).

Steps 4), 5), and 6) are recommended but optional. If steps 4), 5), and 6) are not performed, then the cords must be used only in their tested orientation. More precisely, performing steps 4) and 5) allows TC2 to be used in either orientation; performing step 6)

allows TC1 to be used in either orientation. If steps 4), 5), and 6) are skipped,  $P_1$  becomes the reference power level  $P_{ref}$  in step 8).

- 4) Disconnect TC2 from the power meter and adapter, interchange the ends, reinsert between adapter and power meter, and record a second power level,  $P_2$ .
- 5) Determine the loss as  $10\log(P_0/P_2)$  [dB]. Verify loss is within acceptable limits. If not, clean the plugs and adapter A1, or replace TC1, TC2 and A1 as necessary before continuing. After cleaning or replacement, repeat from step 1). If step 6) is not performed,  $P_2$  becomes the new reference power level  $P_{ref}$  in step 8).
- 6) If the plugs of TC1 are of the same type on both ends, disconnect TC1 from the light source and adapter, interchange the ends, and repeat steps 1) through 5), obtaining a new reference reading  $P_3$  and power readings  $P_4$  and  $P_5$  as above, then proceed to step 7).  $P_5$  becomes the new reference power level  $P_{ref}$  in step 8).
- 7) Insert substitution cord TC3 and adapter A2 between A1 and TC2 as shown in Figure H.9 and record power level  $P_6$ .
- 8) Determine the loss as  $10\log(P_{ref}/P_6)$  [dB]. Verify loss is within acceptable limits. If not, clean the plugs and adapters, or replace TC3 and A2 as necessary before continuing. After cleaning or replacement, repeat from step 1).
- 9) Disconnect TC3 from the adapters, interchange the ends, reinsert and record power level  $P_7$ .
- 10) Determine the loss as  $10\log(P_{ref}/P_7)$  [dB]. Verify loss is within acceptable limits. If not, clean the plugs and adapters, or replace TC3 and adapters as necessary before continuing. After cleaning or replacement, repeat from step 1).

**H.3.5 Test cord verification for the three-cord reference test method when using pinned/unpinned or plug/socket style connectors**

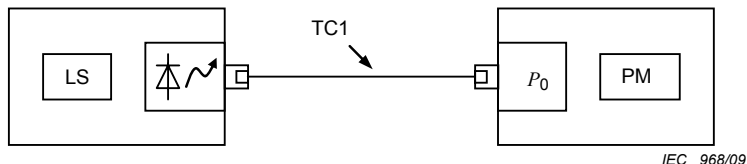

**Key**

- LS light source
- TC1 launch cord
- PM power meter

**Figure H.10 – Obtaining reference power level  $P_0$**

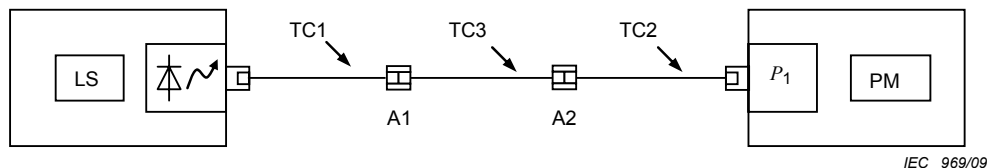

**Key**

- LS light source
- TC1 launch cord
- A1 connector set
- TC3 test cord
- A2 connector set
- TC2 receive cord
- PM power meter

**Figure H.11 – Obtaining power level  $P_1$**

- 1) Obtain reference power measurement  $P_0$  with launch cord TC1 as shown in Figure H.10.
- 2) Insert adapters A1, A2, substitution cord TC3, and receive cord TC2 between TC1 and power meter as shown in Figure J.11 and record  $P_1$ . For plug/socket styles, the adapters are replaced by sockets.
- 3) Determine the loss as  $10\log(P_0/P_1)$  [dB]. Verify loss is within acceptable limits. If not, clean the plugs and adapters, or replace TC1, TC2, TC3 and adapters as necessary before continuing. After cleaning or replacement, repeat from step 1).
- 4) If the plugs of TC3 are of the same type on both ends, disconnect TC3, interchange the ends, reinsert and record power level  $P_2$ . If the plugs are not the same type, skip step 5).
- 5) Determine the loss as  $10\log(P_0/P_2)$  [dB]. Verify loss is within acceptable limits. If not, clean the plugs and adapters, or replace TC1, TC2, TC3 and adapters as necessary before continuing. After cleaning or replacement, repeat from step 1).

NOTE The limits in steps 3) and 5) for this case are normally set to two times the acceptable limit of a single interface.

Steps 6), 7), and 8) are recommended but optional. If steps 6), 7), and 8) are not performed, then TC1 and TC2 must be used only in their tested orientation. More precisely, performing steps 6) and 7) allows TC2 to be used in either orientation; performing step 8) allows TC1 to be used in either orientation.

- 6) In configurations that permit, disconnect TC2 from the power meter and adapter, interchange the ends, reinsert between adapter and power meter, and record a power level,  $P_3$ .
- 7) Determine the loss as  $10\log(P_0/P_3)$  [dB]. Verify loss is within acceptable limits. If not, clean the plugs and adapters, or replace TC2, TC3 and adapter A2 as necessary before continuing. After cleaning or replacement, repeat from step 1).
- 8) If the plugs of TC1 are of the same type on both ends, disconnect TC1 from the light source and adapter, interchange the ends, and repeat steps 1) through 5).

## Bibliography

IEC 60793-1-40, *Optical fibres – Part 1-40: Measurement methods and test procedures – Attenuation*

IEC 60793-2, *Optical fibres – Part 2: Product specifications – General*

IEC 60793-2-10, *Optical fibres – Part 2-10: Product specifications – Sectional specification for category A1 multimode fibres*

IEC 60793-2-50, *Optical fibres – Part 2-50: Product specifications – Sectional specification for class B single-mode fibres*

IEC 61300-3-6, *Fibre optic interconnecting devices and passive components – Basic test and measurement procedures – Part 3-6: Examinations and measurements – Return loss*

IEC 61930, *Fibre optic graphical symbology*

IEC/TR 61931, *Fibre optics – Terminology*

IEC/TR 62316, *Guidance for the interpretation of OTDR backscattering traces*

ISO/IEC 11801, *Information technology – Generic cabling for customer premises*

ISO/IEC 14763-3, *Information technology – Implementation and operation of customer premises cabling – Part 3: Testing of optical fibre cabling*

ISO/IEC 24702, *Information technology – Generic cabling – Industrial premises*

ISO/IEC 24764, *Information technology – Generic cabling for data centre premises*

---



## **THE TELECOMMUNICATIONS INDUSTRY ASSOCIATION**

TIA represents the global information and communications technology (ICT) industry through standards development, advocacy, tradeshows, business opportunities, market intelligence and world-wide environmental regulatory analysis. With roots dating back to 1924, TIA enhances the business environment for broadband, mobile wireless, information technology, networks, cable, satellite and unified communications.

TIA members' products and services empower communications in every industry and market, including healthcare, education, security, public safety, transportation, government, the military, the environment and entertainment. TIA co-owns the SUPERCOMM® tradeshow and is accredited by the American National Standards Institute (ANSI).



**HEADQUARTERS**  
2500 Wilson Boulevard  
Suite 300  
Arlington, VA 22201-3834  
+1.703.907.7700  
+1.703.907.7727 (fax)

**[tiaonline.org](http://tiaonline.org)**