



Couplings

# JAUFLEX<sup>®</sup> Elastic Coupling



## INTRODUCTION

JAURE's competence in power transmission system is based on more than 40 years of experience in the development and manufacture of couplings and power transmission elements.

This is particularly testified by the most extensive supply of the different types of flexible couplings all over the world, being one of the world's leaders in the fields of power transmission.

Computer-aided designs and the latest manufacturing CNC machines and testing equipment, ensure that our products always reflect the state of the art of drive components.

JAURE's Engineering Department closely cooperates with customer's engineers and particularly designs the best tailor-made solutions for their needs. To assure the quality of our new products we test new prototypes in our own test bed under hardest conditions. Continuous research and development, assure to our customers that their equipment will be optimized according to their application.

JAURE commonly cooperates with inspection and classification centres like DNV, GL, ABS, BV, LLOYDS, etc. and usually collaborates with Researches Centres in order to test new materials and innovative solutions.

The design, manufacturing and sales of all of our couplings and drive components are integrated into our Quality System, according to UNE-EN-ISO 9001:1994 certified by DET NORSKE VERITAS (DNV). We also achieved "Type Approvals", which are "product certificates", for different types of our products.

Our final target is always to achieve the complete satisfaction of our customers offering them the best technical solutions at optimum economy.

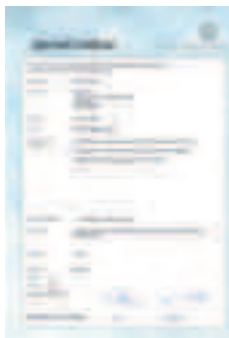

APPROVAL CERTIFICATE  
FROM GL



## Description

The JAUFLEX coupling uses an elastomeric element, and provides the required torsional flexibility for a smooth torque transmission. Through the judicious selection of the element type and coupling size, all shocks or torsional vibration at the driven shaft can be avoided.

The construction of the JAUFLEX coupling allows it to accommodate the inherent offset and angular misalignment between the connected shafts, as well as most axial displacement caused by thermal growth or small machine movements caused by foundation settling or pipe stresses.

Although the JAUFLEX coupling can tolerate many errors in machine alignment, it is best to perform a good alignment, so that the coupling can accommodate later movements between shafts.

The hubs of the JAUFLEX coupling are of the jaw type, made of steel. The cavities for the flexible element are precision machined, not cast. The elastomeric elements are barrel shaped, and interconnected by a ring, thus forming a single piece, easy to instal and remove. Three elastomers are available, of different hardnesses. A high hardness element can be selected for large torque capacity, or a soft element can be used for a smooth torque transmission. The elements eliminate the transmission of torsional vibration both through their elasticity and through their high damping factor.

Air circulation is provided on both sides of the element for easy heat removal.

The main features of the JAUFLEX couplings are:

- It accommodates offset, angular and axial misalignments.
- It is comparatively small in size, and in weight.
- it has a small residual unbalance, both because it is machined, and because the elastic element is very light, and precision molded. Further balancing can be performed if necessary (VDI-2060 Q=6.3 or 2.5)
- The long life of the elastomeric element is ensured by the smooth surfaces of the hub jaws.
- Requires no lubrication, and minimal maintenance.
- Inherently electrically insulated, as there is no metal to-metal contact between the two hubs.

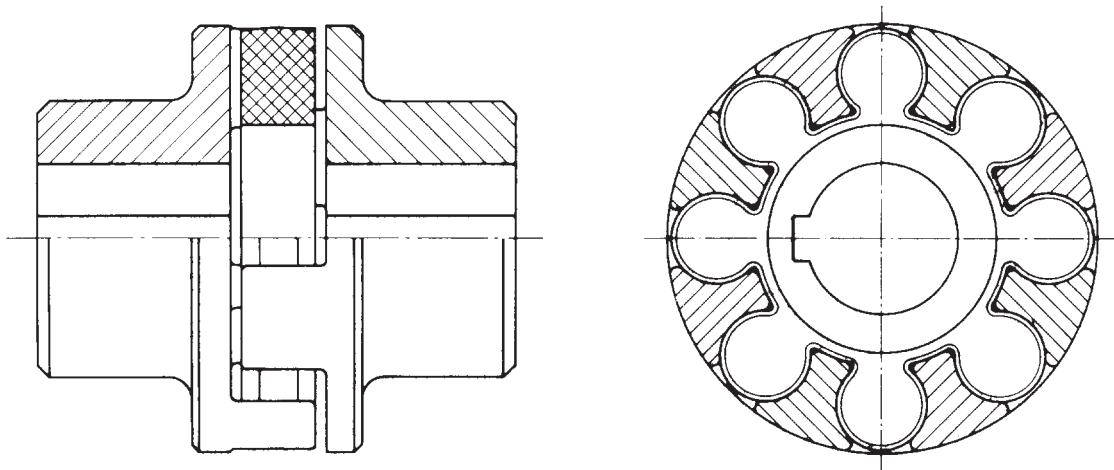

## Configurations

A large number of configurations are available as standard designs, however, the Jaure Engineering Department will be glad to design custom configurations to fit your requirements. Among the many standard configurations are:

- Single engagement configuration with either standard "S-A" or long "S-AL" hubs (used for low key stresses).
- Drop out configuration, which allow the removal of the coupling without moving either machine; type "SDD" or long hubs "SDDL"
- Integral brake drum configuration, with cast iron drum "S-APF" or steel drum "S-APA"
- Floating shaft configuration "SXFS" (double engagement), with incorporated piloting bushings.
- Flywheel configuration "SX" and "SZ", which connects flywheels to solid shafts, and "SXC", which connects flywheels to the universal joints.
- Disk brake configuration "SDD", "SDF" and "STW".
- Torque limiting coupling type "SPL" and "SBR".
- Disengaging configuration type "SES".

## Machinery Misalignment

JAUFLEX couplings can accommodate all machinery misalignments, such as offset, angular and axial displacements. The values given below are maximum values, that must be reduced as the operating speed increases.

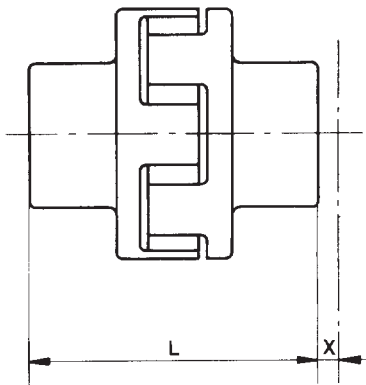

Axial misalignment

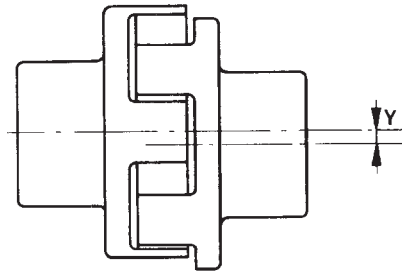

Offset misalignment

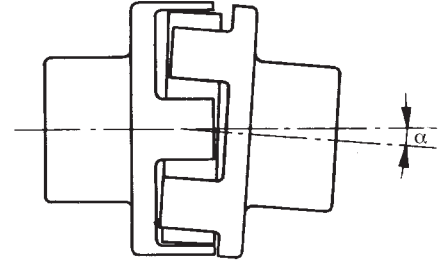

Angular misalignment

The values from the table are misalignments that the coupling can accommodate and still give a satisfactory service life. However, a good machinery alignment will ensure low reaction forces on the bearings, and will increase coupling life.

Coupling size	50	70	85	100	125	145	170	200	230	260	300	360	400
Axial displacement x (mm)	1,5	1,5	2	2,5	3	3	3,5	4,0	4,5	5	5	5	5
Radial displacement y (mm)	0.42	0.61	0.75	0.88	1.1	1.3	1.5	1.8	2	2.3	2.6	3	3.5
Angular displacement (Degrees)	2	2	2	2	1°.30'	1°.30'	1°.30'	1°.30'	1	1	1	1	1

For unusual cases, the Jaure Technical Department will be glad to provide assistance.

## Elastomeric element

Designation	PB 82	VkR	Vk60D
Material	Acrylonitrile Butadiene Rubber (NBR)	Poluyethane elastomer (PUR)	Poluyretham elastomer (PUR)
Colour	Black	Red	White
Hardness (Shore A)	80°	93°	96°
Operating temperature range continuous duty: short duration:	-25°C to 85°C -50°C to 120°C	-35°C to 80°C -40°C to 100°C	-35°C to 80°C -40°C to 100°C
Service life	Very good	Very good	Very good
Wear resistance	Very good	Very good	Very good
Torsional stiffness	Low	Medium	High
Resistance to:			
-Gasoline (petrol)	Good	Good	Very good
-Benzol	Low	Good	Good
-Lubricating oils	Very good	Very good	Very good
-Alkali and acids	Good	Low	Low

# Selection Method

The torques listed in the table No. 1 are valid for ideal operating conditions. Such conditions occur quite seldom, and this is why Jaure provides correction factors to account for various conditions.

Table N.º 1

COUPLING RATINGS							
Size	Torque in Nm						Maximum Speed in r.p.m.
	Pb82 (Black)		Vk R (Red)		Vk 60 D (White)		
	Nom Tkn	Max Tk max.	Nom Tkn	Max Tk max.	Nom Tkn	Max Tk max.	Steel
50	7,3	22	15	40			15000
70	29	87	55	160			11000
85	40	120	75	225			9000
100	70	210	130	390	195	585	7250
125	128	385	250	750	370	1100	6000
145	220	660	400	1200	600	1800	5250
170	340	1020	630	1900	950	2850	4500
200	590	1770	1100	3300	1650	4950	3750
230	900	2700	1700	5150	2580	7740	3250
260	1400	4200	2850	7950	3980	11940	3000
300	2090	6270	3900	11700	5850	17550	2500
360	3450	10350	6500	19500	9700	29100	2150
400	4750	14250	8900	26700	13350	40050	1900

Maximum speed is given according to peripheral speed.  
A hub balancing may be needed.

The main service factors to be applied are accounting for nonuniform (fluctuating) torque transmission, and higher than normal environmental temperatures.

**Torque transmission service factor:** Torque fluctuations can be caused by either the power user machine, or by the driver. Refer to table No. 2 that will give the service factor  $S_L$ . Note that this factor accounts for both the driver and the driven machines.

Table N.º 2

### PRIME MOTOR

Electric motor and turbines

Diesel and petrol engines

6 cil. 4 cil. 3 cil. 2 cil. 1 cil.

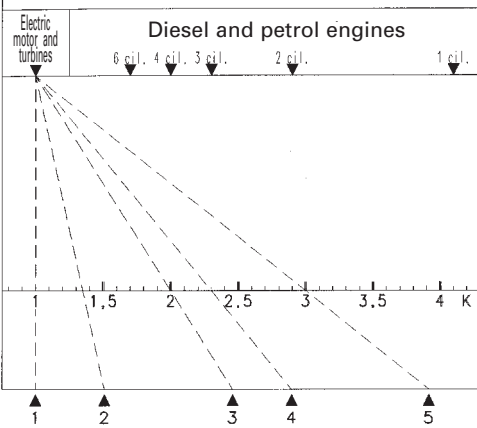

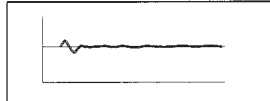
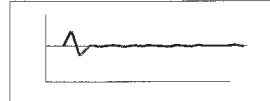
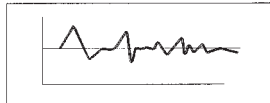
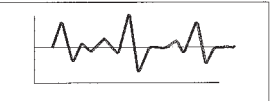
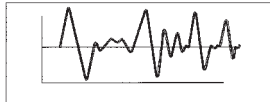
<p>1) Uniform operation, with small masses to be accelerated.</p>  <p>Examples: -Dynamos and light generators -Small fans -Centrifugal pumps -Belt conveyors -Chain conveyors -Screw conveyors</p>	<p>2) Uniform operation, with medium masses to be accelerated.</p>  <p>Examples: -Printing equipment -Washing equipment -Light mixers -Gear pumps -Vane pumps -Saws</p>
<p>3) Medium masses to be accelerated</p>  <p>Examples: -Lifting equipment -Calanders -Centrifugal equipment -Generators -Extrusion machines -Elevators -Machine tools -Piston pumps -Mixers -Bucket conveyors -Rotary compressors -Fans</p>	<p>4) Large masses to be accelerated, irregular operation and shocks</p>  <p>Examples: -Excavators -Presses -Shears -Forging and stamping presses</p>
<p>5) Very large masses to be accelerated, irregular operation and very heavy shocks</p>  <p>Examples: -Ball mills -Hammer mills -Capstans -Onle cylinder compressors -Stone crushers -Riddles -Drilling machines -Mills -Marine engines -High pressure pumps -Feed rolls -Roll straighteners</p>	<p>Technical modifications reserved</p>

**Temperature factor:**

Urethanes in general will become softer as the operating temperature increases, and can transmit less torque. To compensate for unusual temperatures, use Table 3, that will give you the temperature factor  $S_T$ .

Table N.º 3

Temperature Range °C	Temperature Factor	
	Poluyrethane Elastomer (PUR) VKR, VK60d	Acrylonitrile Butadiene Rubber (NBR) Pb82
-20 < t < + 30	1,0	1,0
-30 < t < + 40	1,2	1,0
+40 < t < + 60	1,4	1,0
+60 < t < + 80	1,8	1,2

These temperature factor must be used to correct the driven machine nominal torque.

## 1. Loading through Nominal Torque

The permissible rated coupling torque  $T_{KN}$  must be as high as the rated torque at every operating temperature. The way to proceed is as follows:

If not know, the nominal torque can be obtained through the formula:

$$T_c = 9550 \cdot P/n$$

Where

P = Nominal power installed (Kw)

n = Nominal driving speed (r.p.m.)

$T_c$  = Nominal torque installed (Nm)

The required coupling torque is then determined through:

$$T_{KN} > T_c \cdot S_T$$

Select a coupling that has a rated torque larger than  $T_c \cdot S_T$ . The larger the rating of the selected coupling, the longer the service life of the elastomeric element.

## 2. Loading through Maximum Torque

JAUFLUX couplings can sustain torques much larger than the "nominal", but only occasionally, and for short durations. Such "peak" or maximum torques are known to occur at the start up or during work.

The maximum torques are listed in Table N.º 2. After a coupling size is selected for the "nominal" torque, after corrections, the expected maximum torque generated by the driving machine should be compared with the allowable maximum torque of the selected coupling.

$$T_{Kmax} > T_c \cdot S_T \cdot S_L$$

## 3. Example

The above selection method is going to be shown with an example:

Lifting equipment driven by an electric motor:

Motor power P = 90 Kw.

Operating speed n = 750 r.p.m.

Shaft diameters

d1 = 90 mm

d2 = 80 mm

Operating temperature 20° C.

According to this data the different factors are obtained:

$S_L = 2$  from table N.º 2

$S_T = 1$  from table N.º 3

a) Calculation of the modified nominal torque.

$$T_c \cdot S_T = \frac{9550 \cdot 90}{750} \cdot 1 = 1146 \text{ Nm} < 1700 \text{ Nm}$$

For the S-230-A Vkr the rated coupling torque is  $T_{KN} = 1700 \text{ Nm}$

b) The maximum or peak torques are then compared

$$T_c \cdot S_T \cdot S_L = 1146 \text{ Nm} \cdot 2 \cdot 1 = 2292 \text{ Nm} < 5150$$

For the S-230-A Vkr the peak coupling torque is  $T_{Kmax} = 5150 \text{ Nm}$

c) The shaft diameters d1, d2 must be smaller than the S-230-A maximum shaft diameter, 80/90 < 110.



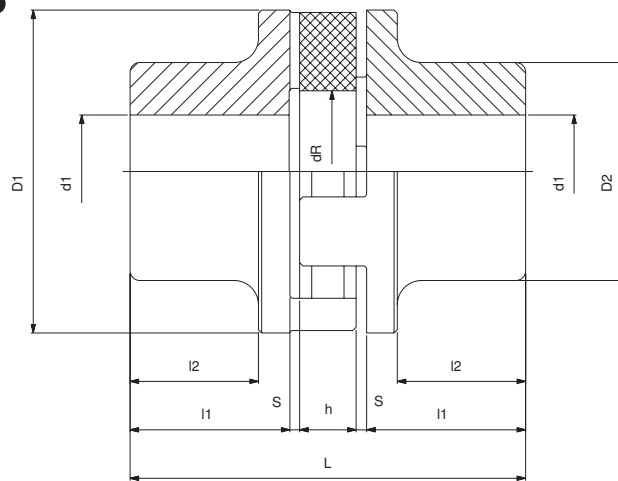

### SHORT HUBS - Type S-A

(1)  $GD^2 = 4J$

Size	Nominal Torque VkR Nm	Max. Torque VkR Nm	d <sub>1</sub>		D <sub>1</sub> mm.	D <sub>2</sub> mm.	L mm.	L <sub>1</sub> mm.	L <sub>2</sub> mm.	S mm.	h mm.	dR mm.	J <sup>(1)</sup> Kgm. <sup>2</sup>	Weight Kgs.
			min. mm.	max. mm.										
S 50 A	15	40	9	25	50	42	75	29.5	23.5	2	12	19	0.00014	0.66
S 70 A	55	160	10	35	70	55	100	38.5	31.5	2.5	18	26	0.00075	1.75
S 85 A	75	225	10	42	85	65	110	43	35	3	18	36	0.0017	2.8
S 100 A	130	390	10	50	105	75	125	49	37.5	3.5	20	46	0.004	5
S 125 A	250	750	13	60	126	90	145	56	44	4	25	55	0.0109	9
S 145 A	400	1200	13	70	145	105	160	60.5	47.5	4.5	30	65	0.0225	10.8
S 170 A	630	1900	18	85	170	120	190	74.5	60.5	5.5	30	90	0.046	17
S 200 A	1100	3300	20	95	200	135	245	98.5	82.5	6.5	35	100	0.108	29.6
S 230 A	1700	5150	28	110	230	150	270	110	91	7.5	35	115	0.1895	41
S 260 A	2650	7950	32	130	260	180	285	112.5	88.5	7.5	45	140	0.3967	59
S 300 A	3900	11700	40	145	300	200	330	131.5	107.5	8.5	50	162	0.73425	87
S 360 A	6500	19500	45	150	360	210	417	172	140	9	55	215	1.534	139.5
S 400 A	8900	26700	80	160	400	225	440	183.5	157	9	55	250	2.0875	160

### LONG HUBS - Type S-AL

(2)  $GD^2 = 4J$

Size	Nominal Torque VkR Nm	Max. Torque VkR Nm	d <sub>1</sub>		D <sub>1</sub> mm.	D <sub>2</sub> mm.	L mm.	L <sub>1</sub> mm.	L <sub>2</sub> mm.	S mm.	h mm.	dR mm.	J <sup>(1)</sup> Kgm. <sup>2</sup>	Weight Kgs.
			min. mm.	max. mm.										
S 50 AL	15	40	9	25	50	42	96	40	34	2	12	19	0.00024	0.97
S 70 AL	55	160	10	35	70	55	143	60	53	2,5	18	26	0.00095	2.20
S 85 AL	75	225	10	42	85	65	184	80	72	3	18	36	0.0025	4.1
S 100 AL	130	390	10	50	105	75	187	80	68.5	3,5	20	46	0.005	5.3
S 125 AL	250	750	13	60	126	90	253	110	98	4	25	55	0.0131	11.7
S 145 AL	400	1200	13	70	145	105	259	110	97	4,5	30	65	0.02	15
S 170 AL	630	1900	18	85	170	120	321	140	126	5,5	30	90	0.07	26
S 200 AL	1100	3300	20	95	200	135	328	140	124	6,5	35	100	0.105	33
S 230 AL	1700	5150	28	110	230	150	390	170	151	7,5	35	115	0.2375	57
S 260 AL	2650	7950	32	130	260	180	400	170	146	7,5	45	140	0.4875	81

- Coupling designation example S 145 A - VkR.
- Technical features and torque capacity see Page 5.
- Coupling torques are given for VkR elastic element.
- Elastic element in three different hardness (PB82, VkR y Vk 60D)

(1) Distance "L" is the minimum distance, this distance has to be increased if thermal expansion is to be expected in the same amount. In this way the axial force between hubs and elastic element due to this expansion is avoided.

(2)  $GD^2 = 4J$

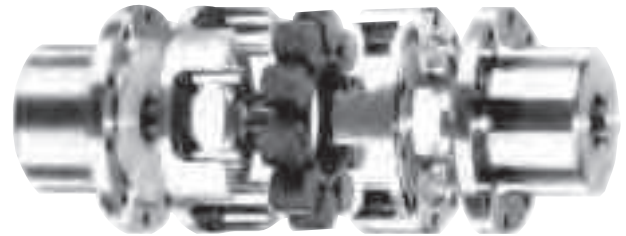
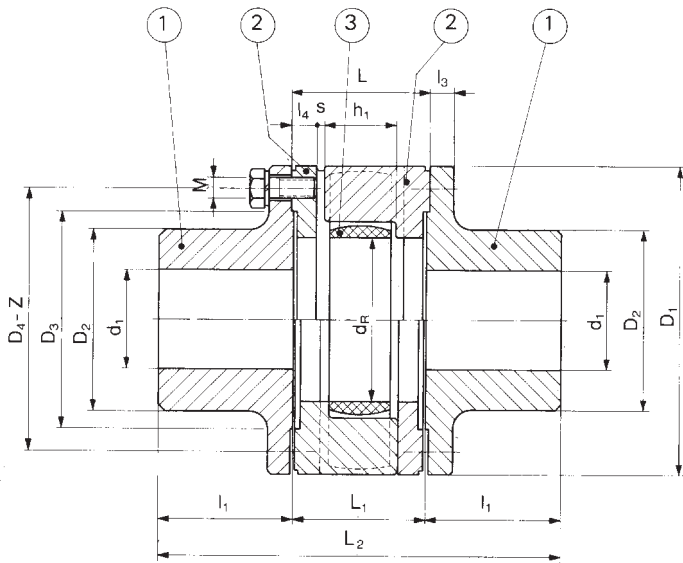

Type SDD	d <sub>1</sub>		D <sub>1</sub>	D <sub>2</sub>	D <sub>3</sub> H7/h7	D <sub>4</sub>	Z (1)	M	l <sub>1</sub>	l <sub>3</sub>	l <sub>4</sub>	S	h <sub>1</sub>	d <sub>R</sub>	L	L <sub>1</sub>	L <sub>2</sub>	M <sub>A</sub> (2)	J (3)	Weight
	mín. mm	máx. mm																		
S 85 DD	10	38	85	60	60	72,5	6	M6	43	8	8	4	21	34	46	43	129	1	0,0021	3
S 100 DD	10	42	105	65	69	87	6	M8	49	10	10,5	5	24	42	56	53	151	2,5	0,0057	5,3
S 125 DD	13	55	126	80	86	106	6	M10	56	11	11	5	29	52	61	58	170	4,9	0,0105	7,9
S 145 DD	13	60	145	90	95	120	6	M12	60,5	12	13,5	5	34	64	71	68	189	8,6	0,0266	11,8
S 170 DD	18	80	170	115	120	145	8	M12	74,5	12,5	13,5	5	34	90	71	68	217	8,6	0,0503	16,7
S 200 DD	20	95	200	135	140	170	8	M14	98,5	14,5	14,5	6	40	100	81	77	274	13,5	0,1189	30,5
S 230 DD	28	110	230	150	170	200	10	M14	110	17,5	15,5	7	41	115	86	81	301	13,5	0,2361	48,7
S 260 DD	32	130	260	180	200	230	10	M16	112,5	22,5	16,5	8	52	140	101	96	321	21	0,4557	69,5
S 300 DD	40	145	300	200	220	260	10	M20	131,5	22	19	8	57	162	111	106	369	41	0,9060	103
S 360 DD	45	160	360	225	230	280	12	M20	172	25	26	8	62	215	130	125	469	41	1,825	163
S 400 DD	80	170	400	240	230	280	14	M22	172	25	26	8	62	250	130	125	469	55	2,2920	173,5

- Coupling designation S - 200 DD Vkr
- In the SDD coupling, the set that includes parts n° 2 and 3 can be mounted and dismantled without the need to move the machine if "L" dimension is respected.
- Technical features and torque capacity see Page 5.
- Hubs in steel, elastic element in three different hardness (PB82,VKR y VK60D).

- (1) Number of bolts.
- (2) Bolt tightening torque
- (3) GD<sup>2</sup> = 4 J



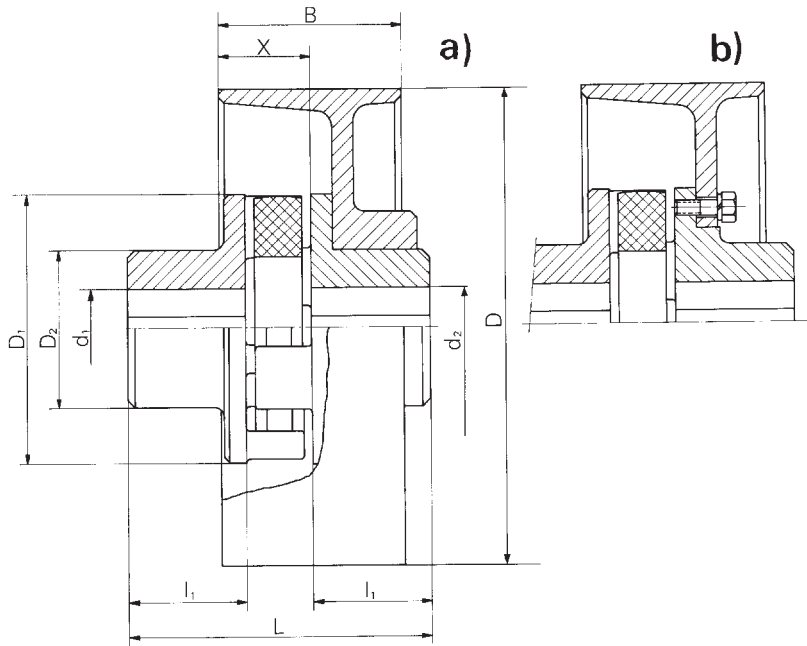

Type S - APF o S - APA	D mm	B mm	d <sub>1</sub> max. mm	d <sub>2</sub> max. mm	R.p.m.		D <sub>1</sub> mm	D <sub>2</sub> mm	X mm	l <sub>1</sub> mm	L mm	J (3) Kgm <sup>2</sup>	Weight Kgs	MA (2) Kgm
					Grey cast iron Drum max.	Steel Drum max.								
* S 100 APF o APA	200	75	50	42	2.700	4.500	105	75	40	49	125	0,0435	8,4	2,5
* S 125 APF o APA	200	75	60	55	2.700	4.500	126	90	40	56	145	0,0503	10,2	4,9
* S 145 APF o APA	200	75	70	65	2.700	4.500	145	105	35	60,5	160	0,0597	12,5	8,6
* S 145 APF o APA	250	95	70	65	2.300	3.800	145	105	50	60,5	160	0,1396	17,5	8,6
* S 170 APF o APA	250	95	85	80	2.300	3.800	170	120	45	74,5	190	0,1658	22,8	8,6
* S 170 APF o APA	315	118	85	80	1.800	3.000	170	120	50	74,5	190	0,4181	29,2	8,6
* S 200 APF o APA	315	118	95	80	1.800	3.000	200	135	50	98,5	245	0,4593	40	13,5
S 200 APF o APA	350	130	95	80	1.600	2.600	200	135	60	98,5	245	0,5822	45	13,5
* S 200 APF o APA	400	150	95	80	1.400	2.300	200	135	75	98,5	245	1,2026	54	13,5
* S 230 APF o APA	400	150	110	100	1.400	2.300	230	150	75	110	270	1,2974	68	13,5
S 230 APF o APA	450	150	110	100	1.300	2.000	230	150	75	110	270	1,525	75	13,5
* S 230 APF o APA	500	190	110	100	1.150	1.900	230	150	100	110	270	3,3899	92	13,5
* S 260 APF o APA	500	190	130	120	1.150	1.900	260	180	100	112,5	285	3,5883	110	21
* S 260 APF o APA	530	190	130	120	1.050	1.700	260	180	100	112,5	285	3,813	125	21
* S 300 APF o APA	630	236	145	130	900	1.500	300	200	120	131,5	330	10,7302	197	41
* S 360 APF o APA	630	236	160	140	900	1.500	360	210	114	172	417	11,564	268	41
* S 360 APF o APA	710	265	160	140	780	1.200	360	210	123	172	417	20,391	326	41
* S 400 APF o APA	710	265	160	150	780	1.200	400	225	132	183,5	440	21,0398	343	41

Example of coupling designation S-200-APA/VKR-400

\* Drum DIN 15431

- Technical features and torque capacity see Page 5.
- Elastic element in three different hardness (PB82, VKR, VKR60D).

(1) Distance "L" is the minimum distance, this distance has to be increased if thermal expansion is to be expected in the same amount. In this way the axial force between hubs and elastic element due to this expansion is avoided.

(2) Bolt tightening torque.

(3)  $GD^2 = 4 J$

## Type SXFS Steel made

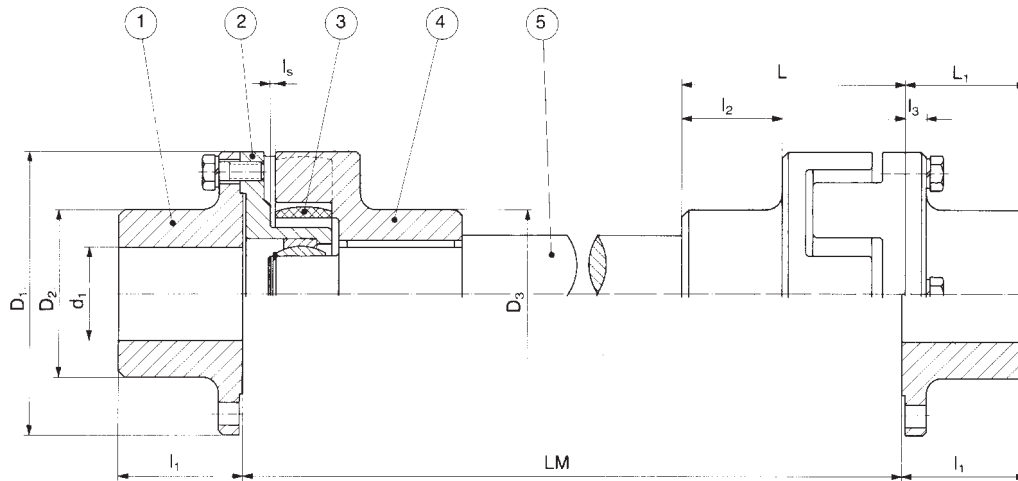

Type SXFS	d <sub>1</sub>		D <sub>1</sub> mm	D <sub>2</sub> mm	D <sub>3</sub> mm	L mm	L <sub>1</sub> mm	LM mm	l <sub>1</sub> mm	l <sub>2</sub> mm	l <sub>3</sub> mm	l <sub>s</sub> mm	J (1) kgm <sup>2</sup>	Weight (1) kg
	min mm	max mm												
SXFS - 100	10	42	105	65	75	82,5	48	To be determined by the customer	49	37,5	10	1,5	0,0046	4,2
SXFS - 125	13	55	126	80	90	95	54,5		56	44	11	1,5	0,0092	6,4
SXFS - 145	13	60	145	90	105	105	59		60,5	47,5	12	1,5	0,0211	9,5
SXFS - 170	18	80	170	115	120	122,5	73		74,5	60,5	12,5	2	0,0454	15
SXFS - 200	20	95	200	135	135	152,5	96,5		98,5	82,5	14,5	2	0,1015	25,8
SXFS - 230	28	110	230	150	150	168	107,5		110	91	17	2,5	0,2054	40
SXFS - 260	32	130	260	180	180	181,5	110		112,5	88,5	22	2,5	0,4467	58
SXFS - 300	40	145	300	200	200	210,5	129		131,5	107,5	22	2,5	0,809	87,5
SXFS - 360	45	160	360	225	210	268,5	169,5		172	140	25	3	1,886	168
SXFS - 400	80	170	400	240	225	259	169,5		172	137	25	3	2,255	174

- Coupling designation example SXFS-230/VkR: LM=500
- To avoid coupling sag and the resulting unbalance, each end of the floating shaft is piloted radially.
- In the SXFS coupling the two end parts of the floating shaft are mounted on hinge joints. The set composed by parts 2, 3, 4 and 5 can be mounted and dismantled without the need to move the machines if l<sub>s</sub> and L are maintained.
- Technical features and torque capacity see Page 5.
- Coupling are made of steel, and the elastomeric elements can be supplied in three different hardness (Pb82, Vkr, Vk60d).

(1) Without part n°5.  
GD<sup>2</sup> = 4J

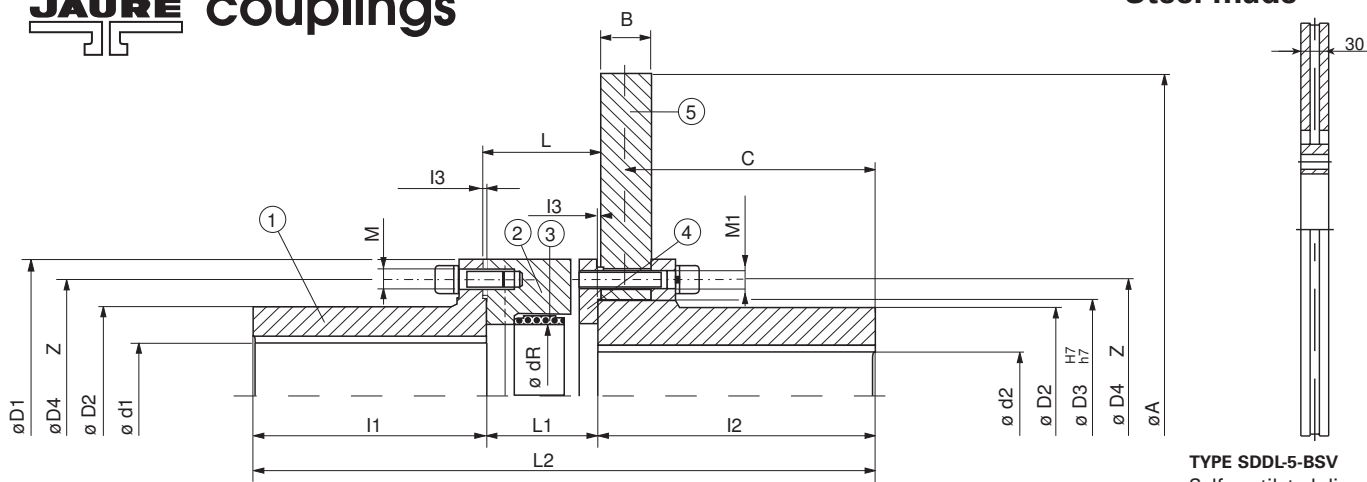
**TYPE SDDL-5-BS**
**TYPE SDDL-5-BSV**  
Self ventilated disc, consult technical department.

SDDL-5-BS	Tnom. Vk 60 D Nm	Máx Torque Nm	N máx.(1) r.p.m	A mm	B mm	C mm	d <sub>1</sub> ,d <sub>2</sub> max mm	D <sub>1</sub> mm	D <sub>2</sub> mm	D <sub>3</sub> H7/h7 mm	D <sub>4</sub> mm	dR mm
SDDL 145-5-BS-355 - 30	600	1800	3000	355	30	150	60	145	85	95	120	64
SDDL 145-5-BS-400 - 30			2600	400								
SDDL 145-5-BS-450 - 30			2300	450								
SDDL 170-5-BS-400 - 30	950	2850	2600	400	30	150	75	170	110	120	145	90
SDDL 170-5-BS-450 - 30			2300	450								
SDDL 170-5-BS-500 - 30			2100	500								
SDDL 200-5-BS-400 - 30	1650	4950	2600	400	30	190	95	200	135	140	170	100
SDDL 200-5-BS-450 - 30			2300	450								
SDDL 200-5-BS-500 - 30			2100	500								
SDDL 200-5-BS-560 - 30			1900	560								
SDDL 230-5-BS-500 - 30	2580	7740	2100	500	30	190	110	230	160	170	200	115
SDDL 230-5-BS-560 - 30			1900	560								
SDDL 230-5-BS-630 - 30			1700	630								
SDDL 230-5-BS-710 - 30			1500	710								
SDDL 260-5-BS-560 - 30	3980	11940	1900	560	30	195	125	260	180	200	230	140
SDDL 260-5-BS-630 - 30			1700	630								
SDDL 260-5-BS-710 - 30			1500	710								
SDDL 300-5-BS-630 - 30	5850	17550	1700	630	30	195	140	300	200	220	260	162
SDDL 300-5-BS-710 - 30			1500	710								
SDDL 300-5-BS-800 - 30			1300	800								
SDDL 300-5-BS-800 - 40			1300	800								
SDDL 360-5-BS-800 - 30	9700	29100	1300	800	30	235	160	360	225	260	310	215
SDDL 360-5-BS-800 - 40			1300	800								
SDDL 360-5-BS-1000 - 40			1100	1000								
SDDL 400-5-BS-800 - 30	13350	40050	1300	800	30	235	160	400	225	300	350	250
SDDL 400-5-BS-800 - 40			1300	800								
SDDL 400-5-BS-1000 - 40			1100	1000								

SDDL-5-BS	L mm	L <sub>1</sub> mm	L <sub>2</sub> mm	l <sub>1</sub> mm	l <sub>2</sub> mm	l <sub>3</sub> mm	z	M (DIN 912-8.8) mm	M1 (DIN 912-8.8) mm	M <sub>A</sub> (2) Nm	J kg m <sup>2</sup>	Weight kg
SDDL 145-5-BS-355 - 30	71	68	344,5	110	166,5	1,5	9	M12 x 30	M12 x 60	84	0,3973	41
SDDL 145-5-BS-400 - 30											0,6219	47
SDDL 145-5-BS-450 - 30											0,9781	55
SDDL 170-5-BS-400 - 30	71	68	374,5	140	166,5	1,5	12	M12 x 30	M12 x 60	84	0,656	54
SDDL 170-5-BS-450 - 30											1,016	62
SDDL 170-5-BS-500 - 30											1,513	71
SDDL 200-5-BS-400 - 30	81	77	454	170	207	2	12	M14 x 30	M14 x 60	132	0,801	76
SDDL 200-5-BS-450 - 30											1,158	84
SDDL 200-5-BS-500 - 30											1,655	93
SDDL 200-5-BS-560 - 30											2,484	105
SDDL 230-5-BS-500 - 30	86	81	458,5	170	207,5	2,5	15	M14 x 35	M14 x 65	132	1,782	116
SDDL 230-5-BS-560 - 30											2,611	128
SDDL 230-5-BS-630 - 30											3,98	143
SDDL 230-5-BS-710 - 30											4,989	163
SDDL 260-5-BS-560 - 30	101	96	518,5	210	212,5	2,5	15	M16 x 40	M16 x 70	206	2,96	150
SDDL 260-5-BS-630 - 30											4,33	168
SDDL 260-5-BS-710 - 30											6,563	185
SDDL 300-5-BS-630 - 30	118	113	535,5	210	212,5	2,5	15	M20 x 50	M20 x 80	410	4,704	189
SDDL 300-5-BS-710 - 30											6,92	225
SDDL 300-5-BS-800 - 30											10,52	250
SDDL 300-5-BS-800 - 40											13,197	285
SDDL 360-5-BS-800 - 30											11,49	311
SDDL 360-5-BS-800 - 40	130	125	627,5	250	252,5	2,5	12	M24 x 55	M24 x 85	710	14,63	346
SDDL 360-5-BS-800 - 40											32,83	433
SDDL 400-5-BS-800 - 30											12,46	323
SDDL 400-5-BS-800 - 40	130	125	627,5	250	252,5	2,5	14	M24 x 55	M24 x 95	710	16,06	358
SDDL 400-5-BS-1000 - 40											33,29	445

(1) Given values for disc in material ST-52,3 balanced to G6, 3 ISO 1940. Consult at Jaure for couplings operating at higher speeds.  
 -The set composed by parts 2, 3, 4 and 5 can be mounted and dismantled without the need to move the machines if L1 is maintained.  
 (2) Tightening torque refers to dry tightening torque.  
 -Above dimensions are only valid for TYPE SDDL-5-BS

# JAUFLEX Couplings for various applications

Herewith are shown various examples for the JAUFLEX coupling.  
Our technical department is ready to study the most suitable configuration to fit your requirements.

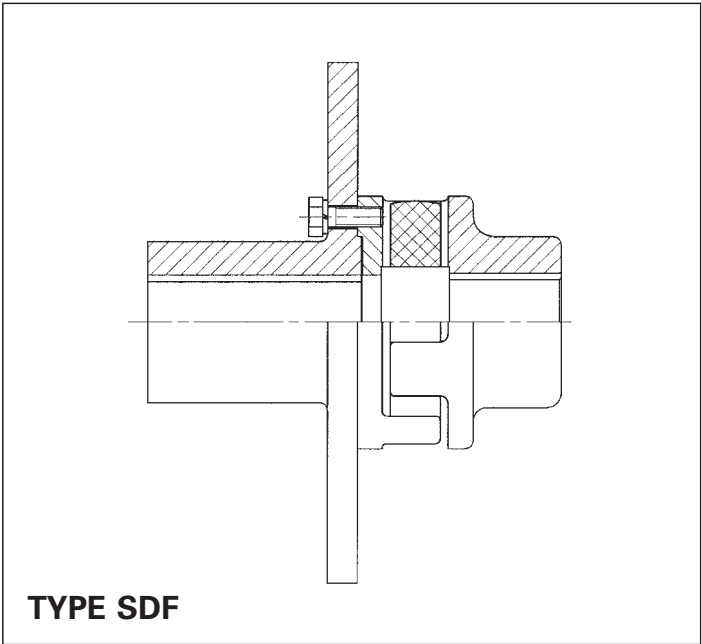
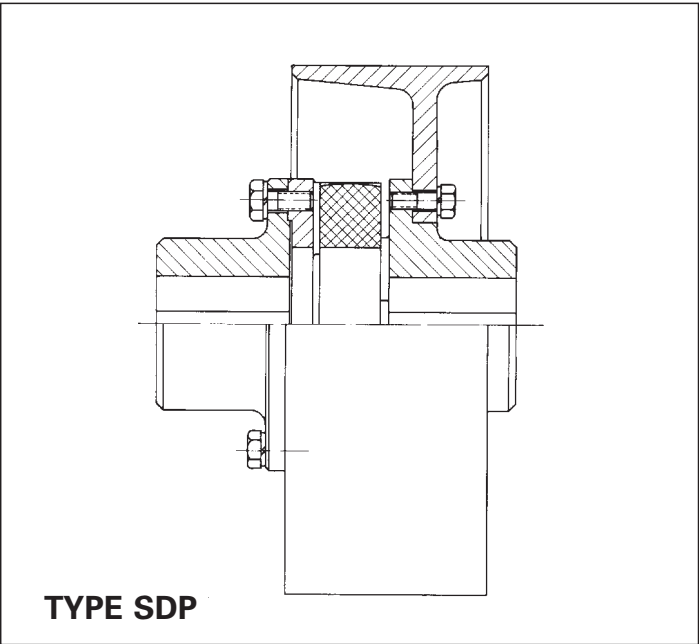
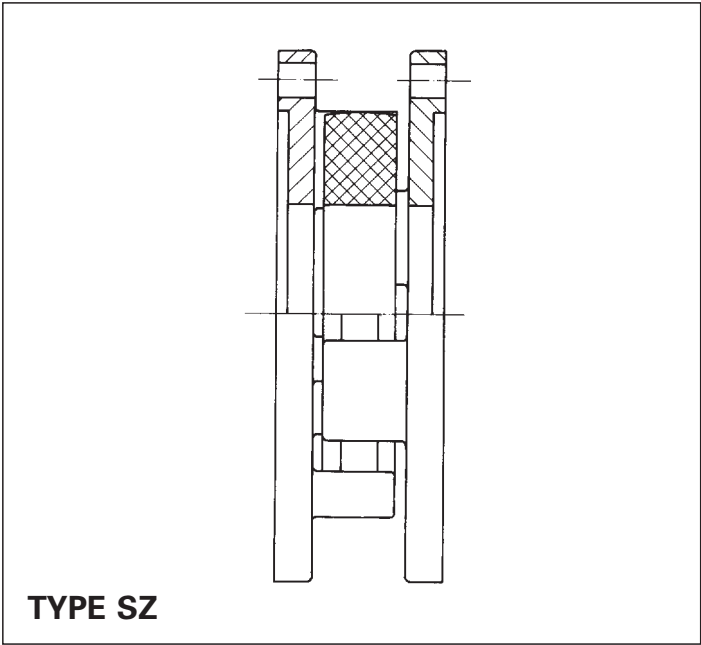
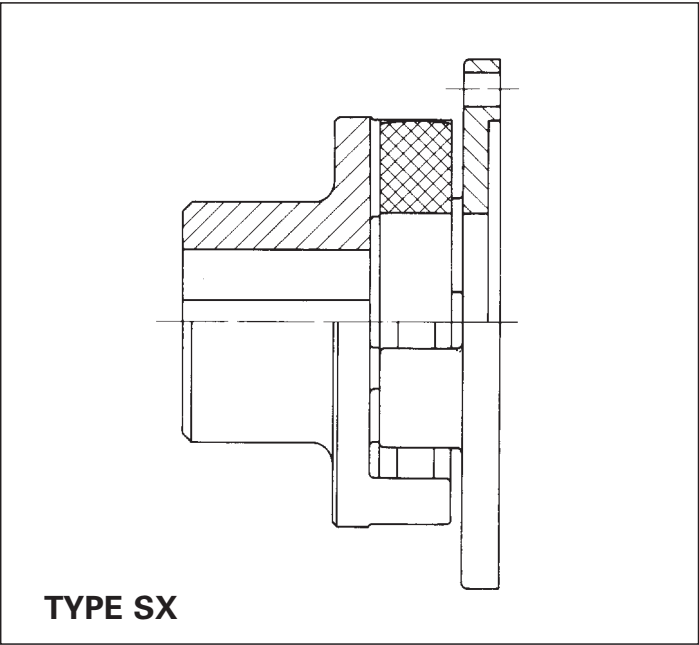
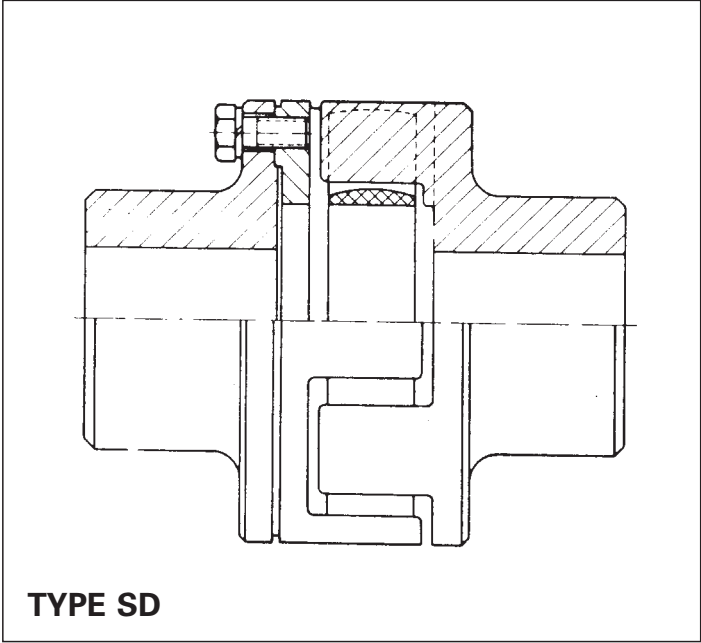

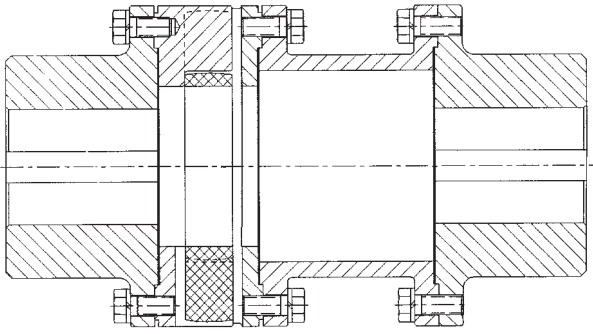

**TYPE SDDX**

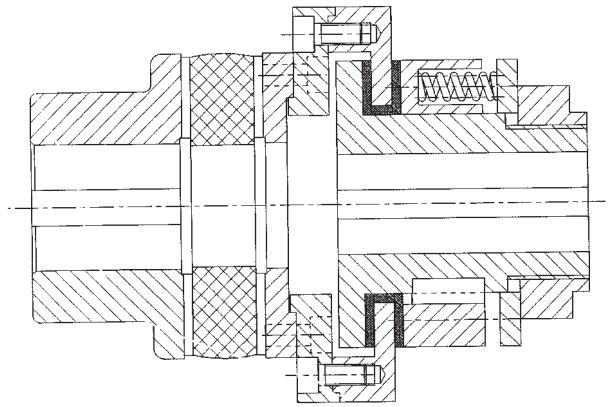

**TYPE SLP**

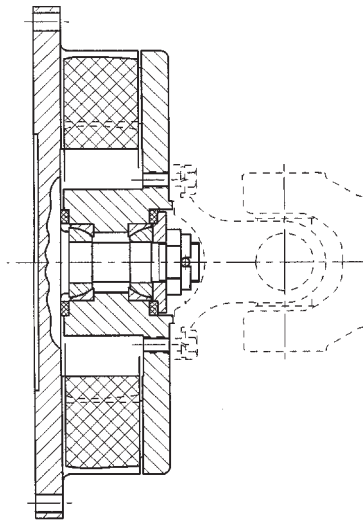

**TYPE SXC**

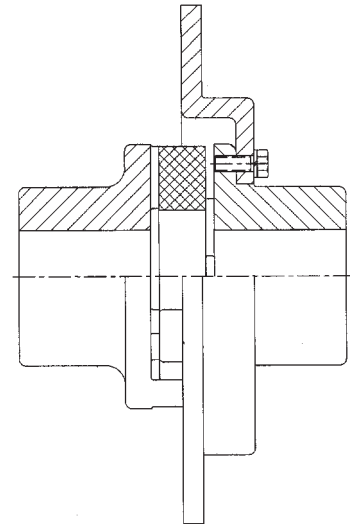

**TYPE STW**

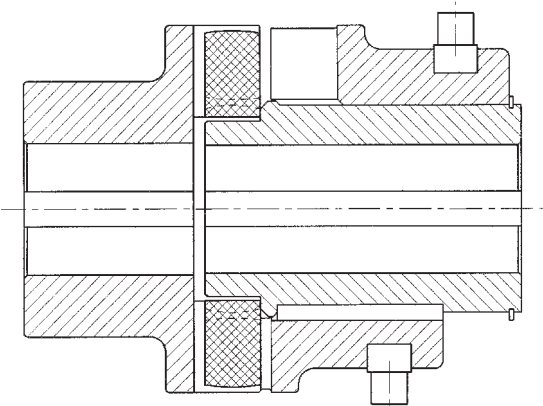

**TYPE SES**

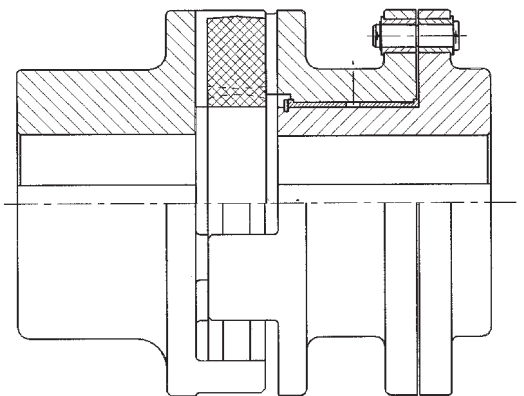

**TYPE SBR**

# Coupling fitting

The following recommendations, according to ISO, are given for shaft/bore fits.

Type of fit	Shaft tolerances	Bore tolerances
Interference fits with parallel key	h 6	S 7
	k6	M 7
	m 6	K 7
	n 6	J 7
	p 6	H 7
Shrink fits* without parallel key	u 6	H 7
	v6	
	x 6	

\* Hub material has to have minimum 350 N/mm<sup>2</sup> yield point.

Other types of fitting can be performed as the examples bellow.

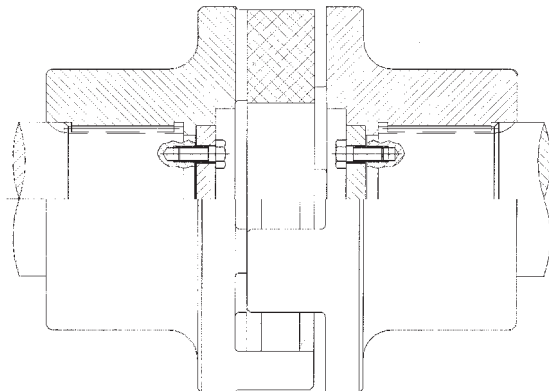

Assembly with spline shaft

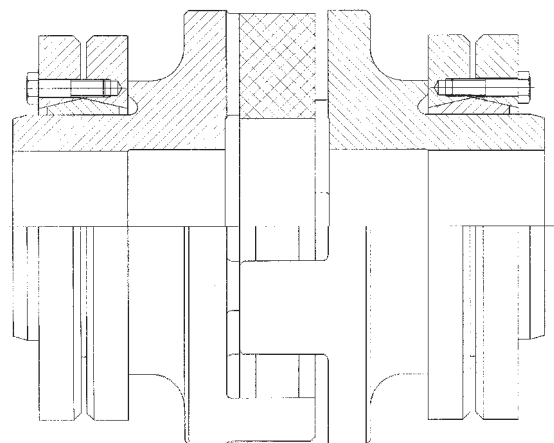

Assembly with locking devices

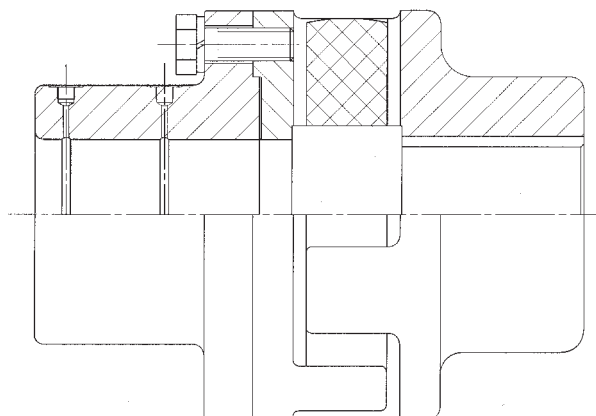

Assembly with shrink fit



## APPLICATIONS



Jauflex® SXFS - 260 for Windmill application.



Jauflex® S - AP with nodular cast iron drum for main hoisting application.



Different types of elastomeric elements

---

# JAURE, S.A - Couplings and transmission elements



■ MT crowned tooth gear coupling.



■ LAMIDISC® all steel disc coupling.

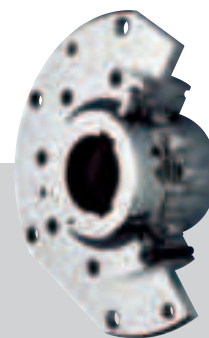

■ Barrel coupling TCB-s®

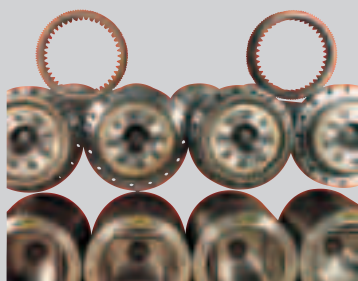

■ Gear spindles for rolling mills.



■ High speed disc couplings LAMIDISC®HP



■ Composite link coupling COMPOLINK®



■ RECORD Flexible Spring Coupling.



■ JAUFLEX® Flexible elastic coupling.



■ IXILFLEX® link type elastic coupling.



**JAURE, S.A.**  
 Ernio bidea, s/n - 20150 ZIZURKIL (Guipúzcoa) SPAIN  
 Phone: +34 943 69.00.54 - Fax: +34 943 69.02.95  
 e-mail: sales.dep@jaure.com  
 www.jaure.com  
 Post address :  
 P.O. Box, 47 -  
 20150 VILLABONA (Guipúzcoa)  
 SPAIN

