

Radial Ball Bearings





PEER Vision

PEER is a dynamic and customer focused bearing manufacturer delivering valued solutions to a global market...

- Valued bearing solutions for agricultural, electrical, fluid, HVAC, lawn & garden, material handling and transmission industries
- Global application engineering support
- TS-16949 certified manufacturing facilities
- Dedicated research and development center
- Testing capabilities include: fatigue life, noise/vibration, mud slurry and salt spray testing
- Flexible manufacturing to allow for low to high volume production
- Customer service excellence



Table of Contents



	Page
R Series	1
600 Series	2
6800 Series	3, 4
6900 Series	5, 6
6000 Series	7, 8
6200 Series	9-11
6300 Series	12, 13
6400 Series	14
1600 Series	15, 16
W6200 Series	17
W6300 Series	18
8000, 87000 & 88000 Series	19, 20
WC8000, WC87000 & WC88000 Series	21, 22
7200 Series	23, 24
7300 Series	25, 26
5200 Series	27
W5200, W5300 Series	28
5300 Series	29
Mast Guide Series	30, 31
Spherical Plain Bearings	32, 33
Thrust Bearings	34
Collar Bearings/Flangette Series	35
1200, 1200K, 1300 & 1300K Series	36
2200, 2200K, 2300 & 2300K Series	37
16000 Series Deep Groove Ball	38, 39
Spherical OD 22 Series	40, 41

continued on next page

Mission Statement

In order to be the most reliable supplier to our customers, PEER intends to meet all of their quality and delivery requirements. We realize that a quality product provides the critical foundation for our relationship with our valued customers. PEER will expect the same level of cooperation from our suppliers.



Table of Contents

(continued)

	Page
Engineering Data	42-78
Precision Radial Ball Bearings	42
Retainer	42
Closures	42
Lubrication	42
Radial Internal Clearance	43
Tolerance Class	43
Material	43
Life and Load Ratings	43
Closure Section	44,45
Tolerances	46-51
Internal Radial Clearance	52,53
Shaft Fit	54-57
Housing Fit	58-60
Load Capacity and Life	61-64
Lubricant Types	65
Grease	65
Oil and Base Fluids	65
Lubrication Methods	66
Operation Speed	66
Lubricant Selection	67
Speed Factor	67-69
Grease Comparison	70,71
Conversion Table	72
Metric Conversion Table	73
Temperature Conversion Table	74
Metric Conversions Table	75
PEER's Sales & Distribution Offices	76
Notes	77,78

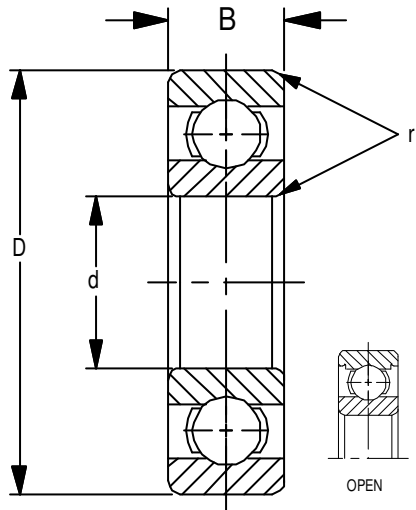

The PEER R series, starting with the 1/4 inch bore, is available up to 1 1/2 inches. The Conrad construction of the R series enables these bearings to take a thrust load as well as a radial load. The well designed ball compliment and selection of retainers permit use of this series in high speed motor applications. This series is produced open, shielded or sealed. Shield and sealed bearings are made slightly wider as shown in the dimension table. Stainless steel 440C material is available upon request. Radial clearance is selected in accordance with applications ranging from C2 -C0-C3-C4 fits.

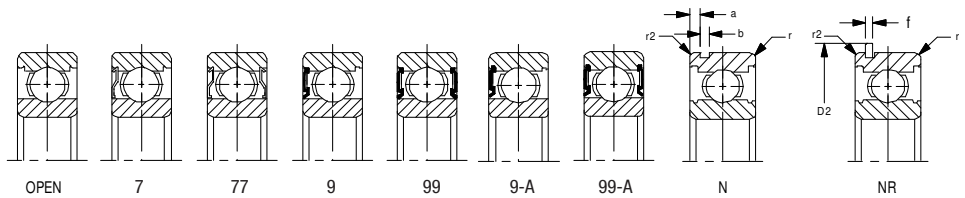

Units: Inches
Metric

Part Number	Bore d	Tolerance +.0000 to minus	OD D	Tolerance +.0000 to minus	Width - B		* fillet radius r	Basic Load Ratings lbf N		Weight lb Kg	Limiting speed (rpm)		
					Open inch	Sealed/ Shielded inch		Dynamic Cr	Static Cor		oil	grease	
													Tolerance +.0000 to minus
R2	1/8	.0003	3/8	.00030	.1562	.1562	.005	144	50	0.003	58,000	49,000	
R2A	.1250	.0003	.3750	.00030	.1719	.1719	.005	.12	641	222	0.001	51,000	42,000
R3	1/8	.0003	1/2	.00030	.1875	.1875	.005	.12	1,148	396	0.003	48,000	41,000
R3A	3/16	.0003	1/2	.00030	.1875	.1875	.005	.12	1,312	492	0.003	48,000	41,000
R4	3/16	.0003	1/2	.00030	.1960	.1960	.005	.12	1,312	489	0.002	43,000	36,000
R4A	.1875	.0003	.5000	.00030	.1960	.1960	.005	.12	1,601	667	0.002	40,000	34,000
R6	1/4	.0003	5/8	.00030	.2500	.2500	.005	.16	2,340	885	0.009	37,000	31,000
R8	1/4	.0003	3/4	.00035	.3750	.3750	.005	.16	3,350	1,410	0.011	30,000	26,000
R10	3/8	.0003	7/8	.00035	.5000	.5000	.005	.16	5,116	2,402	0.018	24,000	20,000
R12	1/2	.0003	1 1/8	.00035	.6250	.6250	.005	.12	5,961	3,238	0.037	21,000	18,000
R14	5/8	.0004	1 3/8	.00045	.7500	.7500	.005	.12	2,110	1,120	0.104	18,000	15,000
R16	3/4	.0004	1 7/8	.00045	.8750	.8750	.005	.12	9,386	4,982	0.047	16,000	14,000
R18	7/8	.0004	2	.00045	1.0000	1.0000	.005	.12	2,270	1,310	0.187	15,000	13,000
R20	1	.0004	2 1/8	.00050	1.1250	1.1250	.005	.12	10,098	5,827	0.085	14,000	12,000
R22	1 1/8	.0004	2 1/4	.00050	1.2500	1.2500	.005	.12	2,980	1,860	0.209	12,500	11,000
R24	1 1/4	.0005	2 1/2	.00050	1.3750	1.3750	.005	.12	13,256	8,274	0.090	11,500	10,000
	1 3/8	.0005	2 3/4	.00050	1.5000	1.5000	.005	.12	2,980	1,860	0.209		
	1 1/2	.0005	3	.00050	1.6250	1.6250	.005	.12	13,256	8,274	0.095		
	1 5/8	.0005	3 1/4	.00050	1.7500	1.7500	.005	.12	3,590	2,320	0.232		
	1 3/4	.0005	3 1/2	.00050	1.8750	1.8750	.005	.12	15,970	10,320	0.105		
	1 7/8	.0005	3 3/4	.00050	2.0000	2.0000	.005	.12	3,770	2,590	0.309		
	2	.0005	4	.00050	2.1250	2.1250	.005	.12	16,770	11,521	0.140		

*Maximum fillet which corner radius of bearing will clear.



600 SERIES

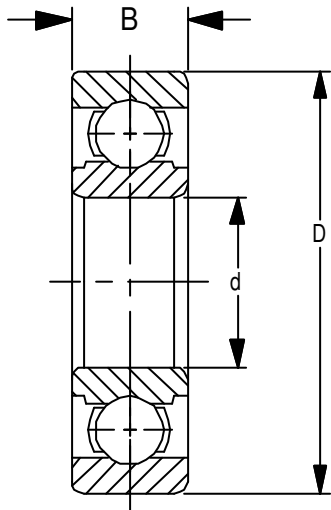

The 600 extra small metric series is produced in bore sizes ranging from 4mm to 9mm. These bearings are designed to take adequate radial and thrust loads in proportion to small shaft sizes. This series may be ordered open, shielded, with contact seals, or non-contact seals. Stainless steel 440C, 600 Series bearings are available upon request.

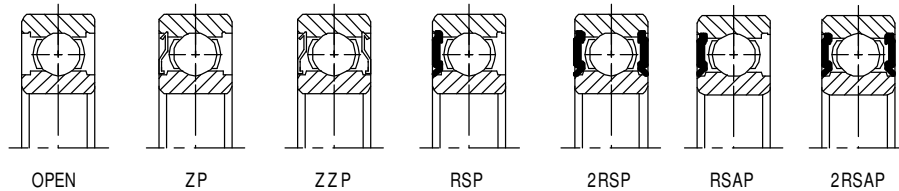

Units: Inches
Metric

Part Number	Bore d	Tolerance +.0000 to minus	OD D	Tolerance +.0000 to minus	Width B	Tolerance +.0000 to minus	* fillet radii r	Basic Load Ratings lbf N		Weight lb Kg	Limiting speed of Open Bearing (rpm)	
								Dynamic Cr	Static Cor		oil	grease
624	.1575	.0003	.5118	.0003	.1969	.0047	.012	295	110	.007	49,000	42,000
	4	.008	13	.008	5	.120	.3	1,312	489	.003		
634	.1575	.0003	.6299	.0003	.1969	.0047	.012	395	153	.011	44,000	37,000
	4	.008	16	.008	5	.120	.3	1,757	681	.005		
625	.1969	.0003	.6299	.0003	.1969	.0047	.012	395	153	.010	44,000	37,000
	5	.008	16	.008	5	.120	.3	1,757	681	.005		
635	.1969	.0003	.7480	.0003	.2362	.0047	.012	527	199	.018	40,000	34,000
	5	.008	19	.009	6	.120	.3	2,390	885	.008		
606	.2362	.0003	.6693	.0003	.2362	.0047	.012	509	195	.013	42,000	35,000
	6	.008	17	.009	6	.120	.3	2,260	867	.006		
626	.2362	.0003	.7480	.0003	.2362	.0047	.012	527	200	.018	40,000	34,000
	6	.008	19	.009	6	.120	.3	2,310	890	.008		
626-4	.2500	.0003	.7480	.0003	.2362	.0047	.012	525	200	.022	40,000	34,000
	6.35	.008	19	.009	6	.120	.3	2,335	890	.010		
607	.2756	.0003	.7480	.0003	.2362	.0047	.012	505	205	.018	40,000	34,000
	7	.008	19	.009	6	.120	.3	2,246	912	.008		
627	.2756	.0003	.8661	.0003	.2756	.0047	.012	750	315	.029	37,000	32,000
	7	.008	22	.009	7	.120	.3	3,336	1,401	.013		
627-4	.2500	.0003	.8661	.0003	.2756	.0047	.012	750	315	.031	36,000	30,000
	6.35	.008	22	.009	7	.120	.3	3,336	1,401	.014		
608	.3150	.0003	.8661	.0003	.2756	.0047	.012	750	315	.026	40,000	34,000
	8	.008	22	.009	7	.120	.3	3,336	1,401	.012		
608-3123	.3123	.0003	.8661	.0003	.2756	.0047	.012	750	315	.031	40,000	34,000
	7.932	.008	22	.009	7	.120	.3	3,336	1,401	.014		
608-3125	.3125	.0003	.8661	.0003	.2756	.0047	.012	750	315	.031	40,000	34,000
	7.9375	.008	22	.009	7	.120	.3	3,336	1,401	.014		
608-3126	.3126	.0003	.8661	.0003	.2756	.0047	.012	750	315	.031	40,000	34,000
	7.940	.008	22	.009	7	.120	.3	3,336	1,401	.014		
609	.3543	.0003	.9449	.0003	.2756	.0047	.012	765	325	.033	36,000	31,000
	9	.008	24	.009	7	.120	.3	3,402	1,445	.015		
629	.3543	.0003	1.0236	.0003	.3150	.0047	.012	1,030	440	.044	35,000	30,000
	9	.008	26	.009	8	.120	.3	4,582	1,970	.020		

*Maximum fillet which corner radius of bearing will clear.

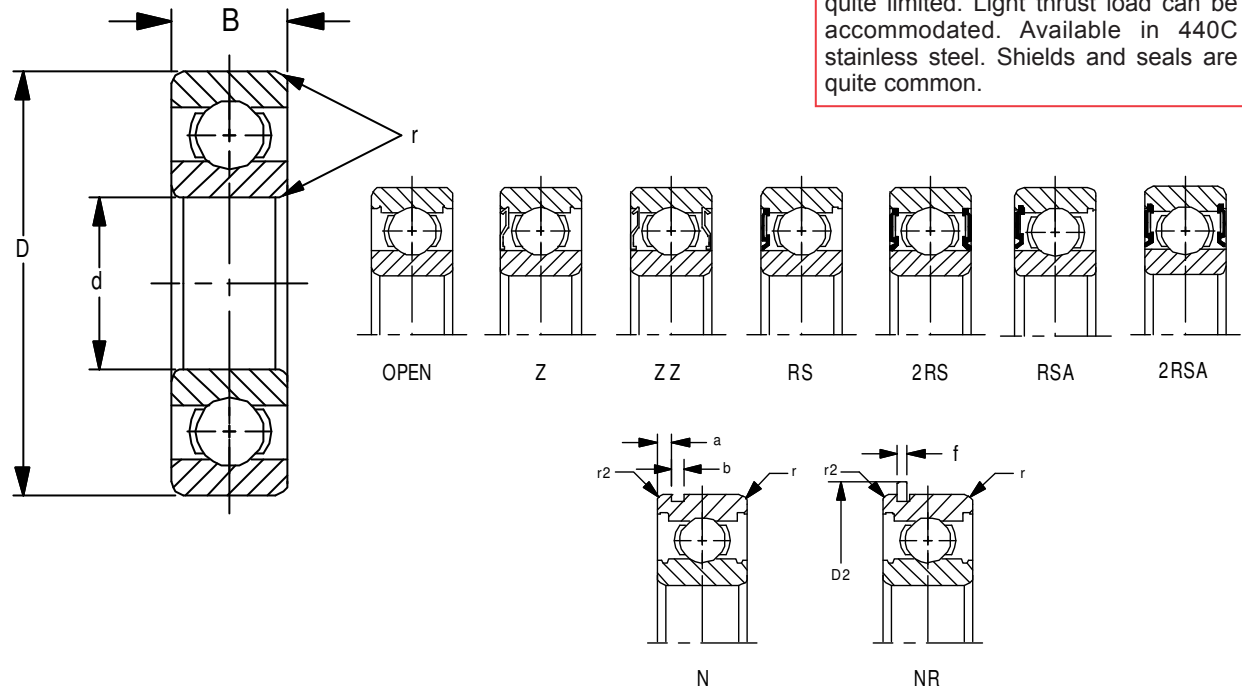

The 6800 series is made with very thin cross sections. Where space limitations are severe this series is very useful. Due to the thin races, loads are quite limited. Light thrust load can be accommodated. Available in 440C stainless steel. Shields and seals are quite common.

Units: Inches
Metric

Part Number	Bore d	Tolerance +.0000 to minus	OD D	Tolerance +.0000 to minus	Width B	Tolerance +.0000 to minus	* fillet radii		snap ring dimensions		snap ring groove dimensions		Basic Load Ratings lbf N		Weight lb Kg	Limiting speed of Open Bearing (rpm)	
							r	r2	D2 Max	f Max	a Max	b Min	Dynamic Cr	Static Cor		oil	grease
6800	.3937	.0003	.7480	.0004	.1969	.0047	.012						410	208	.011	38,000	32,000
	10	.008	19	.009	5	.120	.3						1,830	925	.005		
6801	.4724	.0003	.8268	.0004	.1969	.0047	.012						432	233	.011	35,000	29,000
	12	.008	21	.009	5	.120	.3						1,920	1,040	.005		
6802	.5906	.0003	.9449	.0004	.1969	.0047	.012						466	282	.020	31,000	26,000
	15	.008	24	.009	5	.120	.3						2,080	1,254	.009		
6803	.6693	.0003	1.0236	.0004	.1969	.0047	.012						591	353	.020	28,000	24,000
	17	.008	26	.009	5	.120	.3						2,630	1,570	.009		
6804	.7874	.0004	1.2598	.0005	.2756	.0047	.012	.012	1.370	.033	.051	.037	900	554	.040	25,000	21,000
	20	.010	32	.011	7	.120	.3	.3	34.8	.85	1.3	.95	4,000	2,464	.018		
6805	.9843	.0004	1.4567	.0005	.2756	.0047	.012	.012	1.567	.033	.051	.037	1012	708	.051	21,000	18,000
	25	.010	37	.011	7	.120	.3	.3	39.8	.85	1.3	.95	4,500	3,150	.023		
6806	1.1811	.0004	1.6535	.0005	.2756	.0047	.012	.012	1.764	.033	.051	.037	1,060	821	.051	18,000	15,000
	30	.010	42	.011	7	.120	.3	.3	44.8	.85	1.3	.95	4,700	3,650	.023		
6807	1.3780	.0005	1.8504	.0005	.2756	.0047	.012	.012	1.961	.033	.051	.037	1,100	922	.060	16,000	13,000
	35	.012	47	.011	7	.120	.3	.3	49.8	.85	1.3	.95	4,900	4,100	.027		
6808	1.5748	.0005	2.0472	.0005	.2756	.0047	.012	.012	2.157	.033	.051	.037	1,140	990	.071	14,000	12,000
	40	.012	52	.013	7	.120	.3	.3	54.8	.85	1.3	.95	5,100	4,400	.032		
6809	1.7717	.0005	2.2835	.0005	.2756	.0047	.012	.012	2.394	.033	.051	.037	1,203	1,181	.079	12,000	11,000
	45	.012	58	.013	7	.120	.3	.3	60.8	.85	1.3	.95	5,400	5,300	.036		
6810	1.9685	.0005	2.5591	.0005	.2756	.0047	.012	.012	2.669	.033	.051	.037	1,480	1,400	.110	11,000	9,600
	50	.012	65	.013	7	.120	.3	.3	67.8	.85	1.3	.95	6,600	6,200	.050		

*Maximum fillet which corner radius of bearing will clear.



6800 SERIES (continued)

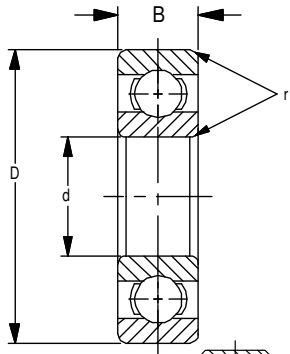

The 6800 series is made with very thin cross sections. Where space limitations are severe this series is very useful. Due to the thin races, loads are quite limited. Light thrust load can be accommodated. Available in 440C stainless steel. Shields and seals are quite common.

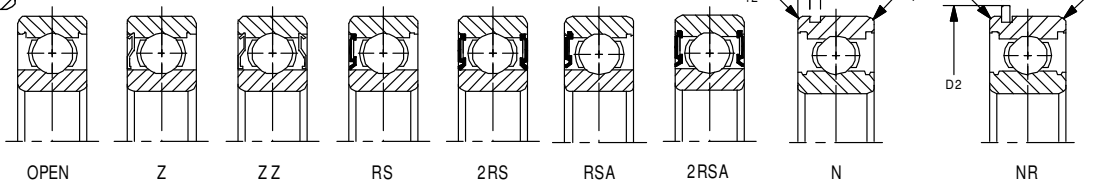

Units: Inches
Metric

Part Number	Bore d	Tolerance +.0000 to minus	OD D	Tolerance +.0000 to minus	Width B	Tolerance +.0000 to minus	* fillet radii		snap ring dimensions		snap ring groove dimensions		Basic Load Ratings lbf N		Weight lb Kg	Limiting speed of Open Bearing (rpm)	
							r	r2	D2 Max	f Max	a Max	b Min	Dynamic Cr	Static Cor		oil	grease
6811	2.1654	.0006	2.8346	.0005	.3543	.0059	.012	.012	2.945	.033	.067	.037	1,980	1,902	.181	10,000	8,700
	55	.015	72	.013	9	.150	.3	.3	74.8	.85	1.7	.95	8,800	8,500	.082		
6812	2.3622	.0006	3.0709	.0005	.3937	.0059	.012	.012	3.256	.044	.067	.051	2,587	2,460	.220	9,400	8,000
	60	.015	78	.013	10	.150	.3	.3	82.7	1.12	1.7	1.3	11,500	10,900	.100		
6813	2.5591	.0006	3.3465	.0006	.3937	.0059	.024	.020	3.520	.044	.067	.051	2,680	2,722	.280	8,700	7,400
	65	.015	85	.015	10	.150	.6	.5	89.4	1.12	1.7	1.3	12,000	12,100	.127		
6814	2.7559	.0006	3.5433	.0006	.3937	.0059	.024	.020	3.717	.044	.067	.051	2,710	2,860	.291	8,100	6,900
	70	.015	90	.015	10	.150	.6	.5	94.4	1.12	1.7	1.3	12,100	12,700	.132		
6815	2.9528	.0006	3.7402	.0006	.3937	.0059	.024	.020	3.913	.044	.067	.051	2,820	3,127	.320	7,600	6,400
	75	.015	95	.015	10	.150	.6	.5	99.4	1.12	1.7	1.3	12,500	13,900	.145		
6816	3.1496	.0006	3.9370	.0006	.3937	.0059	.024	.020	4.110	.044	.067	.051	2,857	3,262	.340	7,100	6,000
	80	.015	100	.015	10	.150	.6	.5	104.4	1.12	1.7	1.3	12,700	14,500	.154		
6817	3.3465	.0008	4.3307	.0006	.5118	.0079	.039	.020	4.555	.044	.083	.051	4,200	4,500	.560	6,700	5,700
	85	.020	110	.015	13	.200	1.0	.5	115.7	1.12	2.1	1.3	18,700	20,000	.254		
6818	3.5433	.0008	4.5276	.0006	.5118	.0079	.039	.020	4.752	.044	.083	.051	4,270	4,725	.591	6,300	5,400
	90	.020	115	.015	13	.200	1.0	.5	120.7	1.12	2.1	1.3	19,000	21,000	.268		
6819	3.7402	.0008	4.7244	.0006	.5118	.0079	.039	.020	4.949	.044	.083	.051	4,330	4,950	.631	5,900	5,000
	95	.020	120	.015	13	.200	1.0	.5	125.7	1.12	2.1	1.3	19,200	22,000	.286		
6820	3.9370	.0008	4.9213	.0007	.5118	.0079	.039	.020	5.146	.044	.083	.051	4,400	5,175	.659	5,600	4,800
	100	.020	125	.018	13	.200	1.0	.5	130.7	1.12	2.1	1.3	19,500	23,000	.299		
6822	4.3307	.0008	5.5118	.0007	.6299	.0079	.039	.020	5.736	.067	.098	.075	6,322	7,312	1.096	5,100	4,300
	110	.020	140	.018	16	.200	1.0	.5	145.7	1.7	2.5	1.9	28,100	32,500	.497		
6824	4.7244	.0008	5.9055	.0007	.6299	.0079	.039	.020	6.130	.067	.098	.075	6,502	7,987	1.184	4,700	4,000
	120	.020	150	.018	16	.200	1.0	.5	155.7	1.7	2.5	1.9	28,900	35,500	.537		
6826	5.1181	.0010	6.4961	.0010	.7087	.0098	.043	.020	6.752	.067	.130	.075	8,325	9,900	1.671	4,300	3,700
	130	.025	165	.025	18	.250	1.1	.5	171.5	1.7	3.3	1.9	37,000	44,000	.758		
6828	5.5118	.0010	6.8898	.0010	.7087	.0098	.043	.020	7.146	.067	.130	.075	8,662	10,800	1.834	4,000	3,400
	140	.025	175	.025	18	.250	1.1	.5	181.5	1.7	3.3	1.9	38,500	48,000	.832		
6830	5.9055	.0010	7.4803	.0012	.7874	.0098	.043	.020	7.736	.067	.130	.075	10,700	13,162	2.535	3,700	3,100
	150	.025	190	.030	20	.250	1.1	.5	196.5	1.7	3.3	1.9	47,500	58,500	1.150		
6832	6.2992	.0010	7.8740	.0012	.7874	.0098	.043	.020	8.130	.067	.130	.075	10,900	13,725	2.712	3,400	2,900
	160	.025	200	.030	20	.250	1.1	.5	206.5	1.7	3.3	1.9	48,500	61,000	1.230		
6834	6.6929	.0010	8.4646	.0012	.8661	.0098	.043						13,500	16,875	4.109	3,200	2,700
	170	.025	215	.030	22	.250	1.1						60,500	75,000	1.864		
6836	7.0866	.0010	8.8583	.0012	.8661	.0098	.043						13,600	17,662	4.381	3,000	2,600
	180	.025	225	.030	22	.250	1.1						60,498	78,500	1.987		

*Maximum fillet which corner radius of bearing will clear.

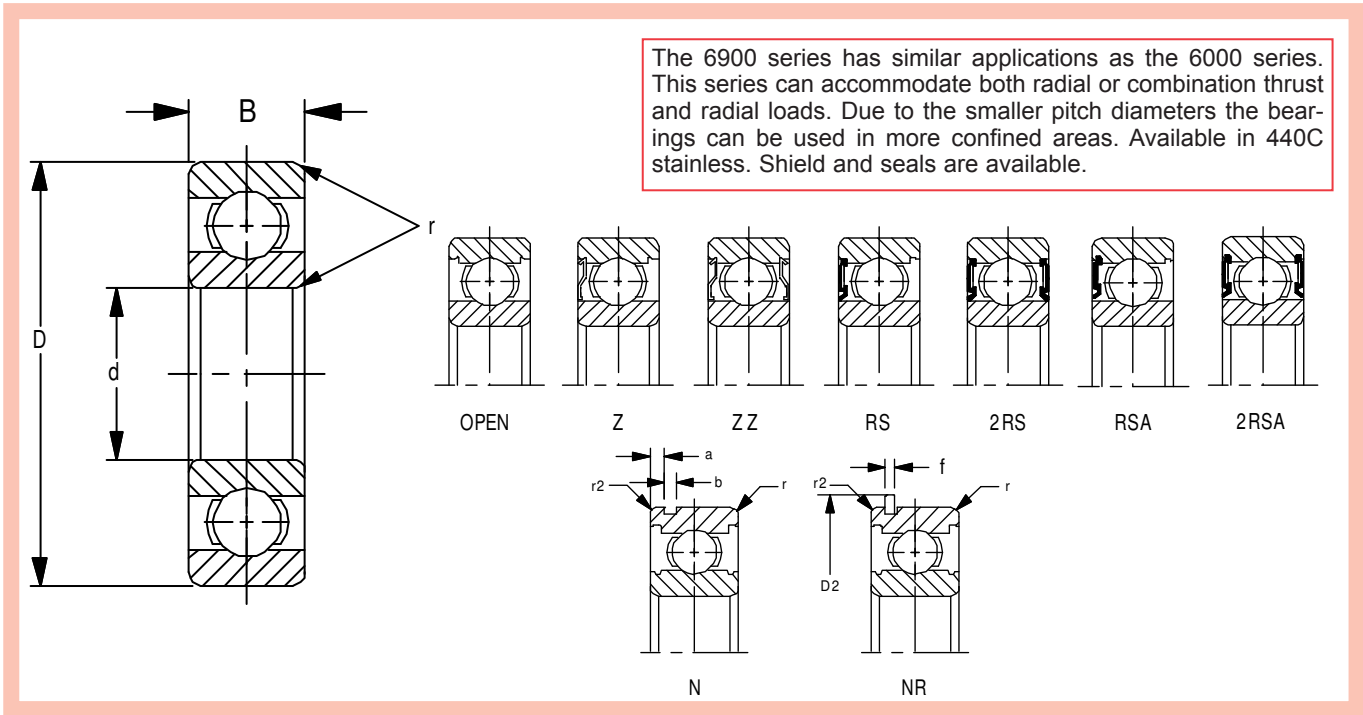

Units: Inches
Metric

Part Number	Bore d	Tolerance +.0000 to minus	OD D	Tolerance +.0000 to minus	Width B	Tolerance +.0000 to minus	* fillet radii		snap ring dimensions		snap ring groove dimensions		Basic Load Ratings lbf N		Weight lb Kg	Limiting speed of Open Bearing (rpm)	
							r	r2	D2 Max	f Max	a Max	b Min	Dynamic Cr	Static Cor		oil	grease
6900	.3937	.0003	.8661	.0004	.2362	.0047	.012	.012	.976	.028	.041	.031	607	285	.020	36,000	30,000
	10	.008	22	.009	6	.120	.3	.3	24.8	.7	1.05	.8	2,700	1,270	.009		
6901	.4724	.0003	.9449	.0004	.2362	.0047	.012	.012	1.055	.028	.041	.031	650	330	.022	32,000	27,000
	12	.008	24	.009	6	.120	.3	.3	26.8	.7	1.05	.8	2,891	1,468	.010		
6902	.5906	.0003	1.1024	.0004	.2756	.0047	.012	.012	1.213	.033	.051	.037	970	979	.031	28,000	24,000
	15	.008	28	.009	7	.120	.3	.3	30.8	.85	1.3	.95	4,315	4,350	.014		
6903	.6693	.0003	1.1811	.0004	.2756	.0047	.012	.012	1.291	.033	.051	.037	1,050	580	.040	26,000	22,000
	17	.008	30	.009	7	.120	.3	.3	32.8	.85	1.3	.95	4,671	2,579	.018		
6904	.7874	.0004	1.4567	.0005	.3543	.0047	.012	.012	1.567	.033	.067	.037	1,440	832	.079	23,000	19,000
6905	20	.010	37	.011	9	.120	.3	.3	39.8	.85	1.7	.95	6,400	3,700	.036		
	.9843	.0004	1.6535	.0005	.3543	.0047	.012	.012	1.764	.033	.067	.037	1,586	1,023	.090	19,000	16,000
6906	25	.010	42	.011	9	.120	.3	.3	44.8	.85	1.7	.95	7,050	4,550	.041		
	1.1811	.0004	1.8504	.0005	.3543	.0047	.012	.012	1.961	.033	.067	.037	1,631	1,130	.115	17,000	14,000
6907	30	.010	47	.011	9	.120	.3	.3	49.8	.85	1.7	.95	7,250	5,026	.052		
	1.3780	.0005	2.1654	.0005	.3937	.0047	.024	.020	2.276	.033	.067	.037	2,511	1,670	.165	15,000	12,000
6908	35	.012	55	.013	10	.120	.6	.5	57.8	.85	1.7	.95	11,165	7,429	.075		
	1.5748	.0005	2.4409	.0005	.4724	.0047	.024	.020	2.551	.033	.067	.037	3,252	2,300	.247	13,000	11,000
6909	40	.012	62	.013	12	.120	.6	.5	64.8	.85	1.7	.95	14,457	10,231	.112		
	1.7717	.0005	2.6772	.0005	.4724	.0047	.024	.020	2.787	.033	.067	.037	3,403	2,532	.278	12,000	9,800
6910	45	.012	68	.013	12	.120	.6	.5	70.8	.85	1.7	.95	15,125	11,254	.126		
	1.9685	.0005	2.8346	.0005	.4724	.0047	.024	.020	2.945	.033	.067	.037	3,500	2,750	.290	11,000	8,900
6911	50	.012	72	.013	12	.120	.6	.5	74.8	.85	1.7	.95	15,569	12,233	.132		
	2.1654	.0006	3.1496	.0005	.5118	.0059	.039	.020	3.323	.044	.083	.051	3,602	2,992	.417	9,600	8,200
6912	55	.015	80	.013	13	.150	1.0	.5	84.4	1.12	2.1	1.3	16,012	13,300	.189		
	2.3622	.0006	3.3465	.0006	.5118	.0059	.039	.020	3.520	.044	.083	.051	4,360	3,650	.423	8,900	7,600
6913	60	.015	85	.015	13	.150	1.0	.5	89.4	1.12	2.1	1.3	19,395	16,300	.192		
	2.5591	.0006	3.5433	.0006	.5118	.0059	.039	.020	3.717	.044	.083	.051	3,915	3,622	.481	8,200	7,000
	65	.015	90	.015	13	.150	1.0	.5	94.4	1.12	2.1	1.3	17,400	16,100	.218		

*Maximum fillet which corner radius of bearing will clear.



6900 SERIES (continued)

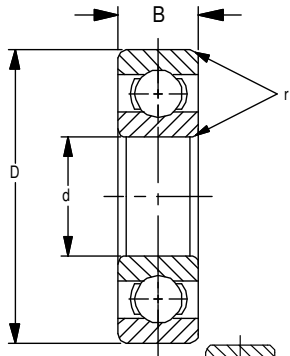

The 6900 series has similar applications as the 6000 series. This series can accommodate both radial or combination thrust and radial loads. Due to the smaller pitch diameters the bearings can be used in more confined areas. Available in 440C stainless. Shield and seals are available.

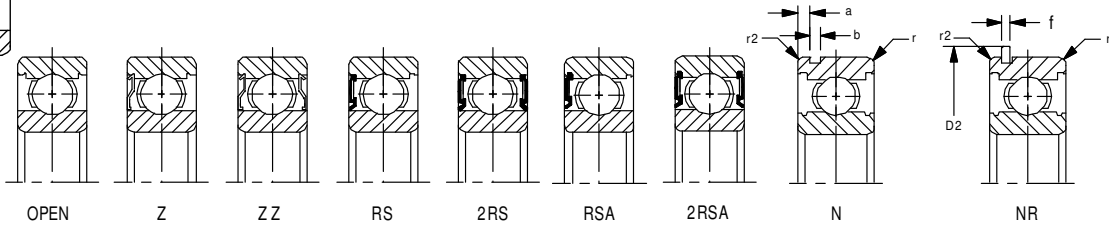

Units: Inches
Metric

Part Number	Bore d	Tolerance +.0000 to minus	OD D	Tolerance +.0000 to minus	Width B	Tolerance +.0000 to minus	* fillet radii		snap ring dimensions		snap ring groove dimensions		Basic Load Ratings lbf N		Weight lb Kg	Limiting speed of Open Bearing (rpm)	
							r	r ₂	D ₂ Max	f Max	a Max	b Min	Dynamic Cr	Static Cor		oil	grease
6914	2.7559	.0006	3.9370	.0006	.6299	.0059	.039	.020	4.110	.044	.098	.051	5,354	4,770	.769	7,700	6,500
	70	.015	100	.015	16	.150	1.0	.5	104.4	1.12	2.5	1.3	23,796	21,200	.349		
6915	2.9528	.0006	4.1339	.0006	.6299	.0059	.039	.020	4.358	.044	.098	.051	5,504	5,060	.789	7,400	6,100
	75	.015	105	.015	16	.150	1.0	.5	110.7	1.12	2.5	1.3	24,464	22,509	.358		
6916	3.1496	.0006	4.3307	.0006	.6299	.0059	.039	.020	4.555	.044	.098	.051	5,625	5,390	.862	6,700	5,700
	80	.015	110	.015	16	.150	1.0	.5	115.7	1.12	2.5	1.3	25,000	23,977	.391		
6917	3.3465	.0008	4.7244	.0006	.7087	.0079	.043	.020	4.949	.044	.130	.051	7,200	6,660	1.213	6,300	5,400
	85	.020	120	.015	18	.200	1.1	.5	125.7	1.12	3.3	1.3	32,000	29,600	.550		
6918	3.5433	.0008	4.9213	.0007	.7087	.0079	.043	.020	5.146	.044	.130	.051	7,425	7,105	1.290	6,000	5,100
	90	.020	125	.018	18	.200	1.1	.5	130.71	1.12	3.3	1.3	33,000	31,580	.585		
6919	3.7402	.0008	5.1181	.0007	.7087	.0079	.043	.020	5.343	.044	.130	.051	7,555	7,555	1.325	5,700	4,800
	95	.020	130	.018	18	.200	1.1	.5	135.7	1.12	3.3	1.3	33,582	33,582	.601		
6920	3.9370	.0008	5.5118	.0007	.7874	.0079	.043	.020	5.736	.067	.130	.075	9,675	9,450	1.825	5,300	4,500
	100	.020	140	.018	20	.200	1.1	.5	145.7	1.7	3.3	1.9	43,000	42,000	.828		
6921	4.1339	.0008	5.7087	.0007	.7874	.0079	.043	.020	5.933	.067	.130	.075	9,562	9,460	1.887	5,300	4,300
	105	.020	145	.018	20	.200	1.1	.5	150.7	1.7	3.3	1.9	42,500	42,082	.856		
6922	4.3307	.0008	5.9055	.0007	.7874	.0079	.043	.020	6.130	.067	.130	.075	9,807	10,000	1.969	5,000	4,300
	110	.020	150	.018	20	.200	1.1	.5	155.7	1.7	3.3	1.9	43,590	44,500	.893		
6924	4.7244	.0008	6.4961	.0010	.8661	.0079	.043	.020	6.752	.067	.146	.075	11,925	12,209	2.619	4,400	3,800
	120	.020	165	.025	22	.200	1.1	.5	171.5	1.7	3.7	1.9	53,000	54,265	1.188		
6926	5.1181	.0010	7.0866	.0010	.9449	.0098	.059	.020	7.342	.067	.146	.075	14,625	15,187	3.461	4,100	3,500
	130	.025	180	.025	24	.250	1.5	.5	186.5	1.7	3.7	1.9	65,000	67,500	1.570		
6928	5.5118	.0010	7.4803	.0012	.9449	.0098	.059	.020	7.736	.067	.146	.075	14,962	16,100	3.682	3,800	3,200
	140	.025	190	.030	24	.250	1.5	.5	196.5	1.7	3.7	1.9	66,500	72,000	1.670		
6930	5.9055	.0010	8.2677	.0012	1.1024	.0098	.079						19,000	20,362	6.636	3,500	3,000
	150	.025	210	.030	28	.250	2.0						85,000	90,500	3.010		
6932	6.2992	.0010	8.6614	.0012	1.1024	.0098	.079						19,575	21,600	5.975	3,300	2,800
	160	.025	220	.030	28	.250	2.0						87,000	96,000	2.710		
6934	6.6929	.0010	9.0551	.0012	1.1024	.0098	.079						19,350	21,825	7.275	3,100	2,600
	170	.025	230	.030	28	.250	2.0						86,000	97,000	3.300		
6936	7.0866	.0010	9.8425	.0012	1.2992	.0098	.079						26,752	28,800	9.171	2,900	2,400
	180	.025	250	.030	33	.250	2.0						119,000	128,114	4.160		
6938	7.4803	.0012	1.2362	.0014	1.2992	.0118	.079						25,425	28,575	11.420	2,700	2,300
	190	.030	260	.035	33	.300	2.0						113,000	127,000	5.180		
6940	7.8740	.0012	11.0236	.0014	1.4961	.0118	.083						32,100	37,800	16.050	2,600	2,200
	200	.030	280	.035	38	.300	2.10						157,000	168,000	7.280		

*Maximum fillet which corner radius of bearing will clear.

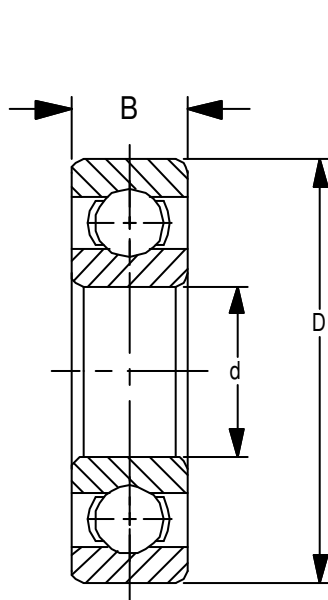

This deep groove, Conrad construction bearing is specifically designed to provide maximum performance by means of precise ball complement selection. The honed raceways offer a perfectly balanced bearing capable of operating under straight radial, thrust or combination loads. This series is available with shields, Buna N seals, or locating rings. Sealed bearings may be obtained with either low or high starting torques. Consult Peer's engineering staff for proper selection. Stainless steel 440C material is available upon request. Radial clearance is selected in accordance with applications ranging from C2 - C0 - C3 - C4 fits.

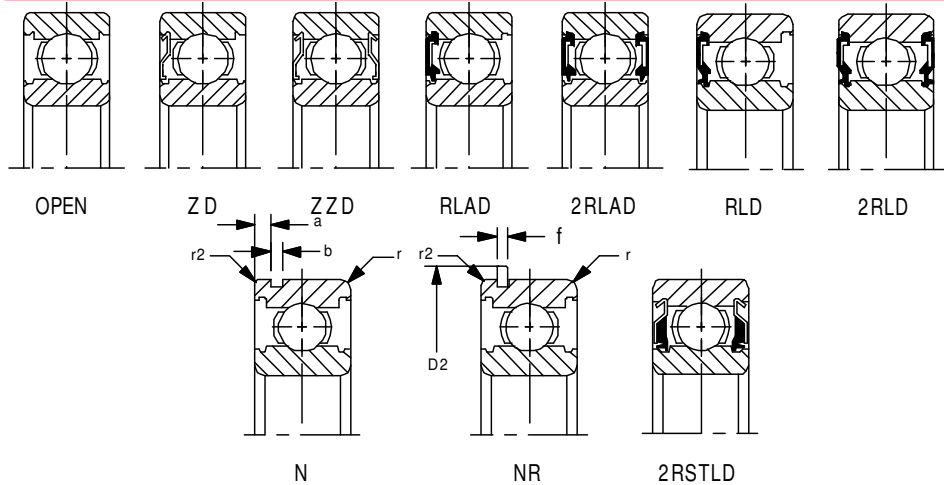

Units: Inches
Metric

Part Number	Bore d	Tolerance +.0000 to minus	OD D	Tolerance +.0000 to minus	Width B	Tolerance +.0000 to minus	* fillet radii		snap ring dimensions		snap ring groove dimensions		Basic Load Ratings lbf N		Weight lb Kg	Limiting speed of Open Bearing (rpm)	
							r	r2	D2 Max	f Max	a Max	b Min	Dynamic Cr	Static Cor		oil	grease
6000	.3937	.0003	1.0236	.0004	.3150	.0047	.012	.012	1.130	.028	.068	.031	1,030	440	.042	34,000	29,000
	10	.008	26	.009	8	.120	.3	.3	28.7	.7	1.73	.8	4,550	1,970	.019		
6001	.4724	.0003	1.1024	.0004	.3150	.0047	.012	.012	1.209	.033	.068	.037	1,150	540	.046	30,000	26,000
	12	.008	28	.009	8	.120	.3	.3	30.7	.85	1.73	.95	5,116	2,390	.021		
6002	.5906	.0003	1.2598	.0004	.3543	.0047	.012	.012	1.445	.044	.081	.053	1,260	635	.066	26,000	22,000
	15	.008	32	.011	9	.120	.3	.3	36.7	1.12	2.06	1.35	5,605	2,825	.030		
6003	.6693	.0003	1.3780	.0004	.3937	.0047	.012	.012	1.563	.044	.081	.053	1,530	755	.086	24,000	20,000
	17	.008	35	.011	10	.120	.3	.3	39.7	1.12	2.06	1.35	6,806	3,359	.039		
6004	.7874	.0004	1.6535	.0004	.4724	.0047	.024	.020	1.823	.044	.081	.053	2,110	1,136	.152	21,000	18,000
	20	.010	42	.011	12	.120	.6	.5	46.3	1.12	2.06	1.35	9,400	5,050	.069		
60/22	.8661	.0004	1.7323	.0004	.4724	.0047	.024	.020	1.902	.044	.081	.053	2,110	1,136	.163	20,000	17,000
	22	.010	44	.011	12	.120	.6	.5	48.3	1.12	2.06	1.35	9,400	5,050	.074		
6005	.9843	.0004	1.8504	.0004	.4724	.0047	.024	.020	2.075	.044	.081	.053	2,272	1,320	.176	18,000	15,000
	25	.010	47	.011	12	.120	.6	.5	52.7	1.12	2.06	1.35	10,100	5,850	.080		
60/28	1.1024	.0004	2.2835	.0005	.6299	.0047	.024	.020	2.280	.044	.081	.053	2,800	1,660	.216	16,000	14,000
	28	.010	52	.013	12	.120	.6	.5	57.9	1.12	2.06	1.35	12,500	7,400	.098		
6006	1.1811	.0004	2.1654	.0005	.5118	.0047	.039	.020	2.390	.044	.082	.053	2,970	1,860	.256	15,000	13,000
	30	.010	55	.013	13	.120	1.0	.5	60.7	1.12	2.08	1.35	13,212	8,300	.116		
60/32	1.2598	.0005	2.2835	.0005	.5118	.0047	.039	.020	2.508	.044	.082	.053	3,400	2,050	.284	15,000	12,000
	32	.012	58	.013	13	.120	1.0	.5	63.7	1.12	2.08	1.35	15,100	9,150	.129		
6007	1.3780	.0005	2.4409	.0005	.5512	.0047	.039	.020	2.665	.067	.082	.075	3,600	2,315	.342	14,000	12,000
	35	.012	62	.013	14	.120	1.0	.5	67.7	1.7	2.08	1.9	16,014	10,298	.155		
6008	1.5748	.0005	2.6772	.0005	.5906	.0047	.039	.020	2.937	.067	.098	.075	3,750	2,600	.419	12,000	10,000
	40	.012	68	.013	15	.120	1.0	.5	74.6	1.7	2.49	1.9	16,800	11,500	.190		
6009	1.7717	.0005	2.9528	.0005	.6299	.0047	.039	.020	3.213	.067	.098	.075	4,725	3,420	.522	11,000	9,200
	45	.012	75	.013	16	.120	1.0	.5	81.6	1.7	2.49	1.9	21,000	15,200	.237		
6010	1.9685	.0005	3.1496	.0005	.6299	.0047	.039	.020	3.409	.067	.098	.075	4,900	3,735	.575	9,800	8,400
	50	.012	80	.013	16	.120	1.0	.5	86.6	1.7	2.49	1.9	21,797	16,600	.261		

*Maximum fillet which corner radius of bearing will clear.



6000 SERIES (continued)

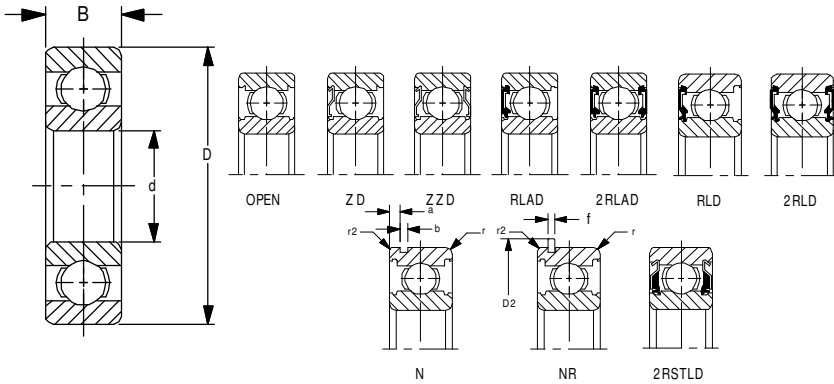

This deep groove, Conrad construction bearing is specifically designed to provide maximum performance by means of precise ball complement selection. The honed raceways offer a perfectly balanced bearing capable of operating under straight radial, thrust or combination loads. This series is available with shields, Buna N seals, or locating rings. Sealed bearings may be obtained with either low or high starting torques. Consult Peer's engineering staff for proper selection. Stainless steel 440C material is available upon request. Radial clearance is selected in accordance with applications ranging from C2 - C0 - C3 - C4 fits.

Units: Inches
Metric

Part Number	Bore d	Tolerance +.0000 to minus	OD D	Tolerance +.0000 to minus	Width B	Tolerance +.0000 to minus	* fillet radii		snap ring dimensions		snap ring groove dimensions		Basic Load Ratings N		Weight lb Kg	Limiting speed of Open Bearing (rpm)	
							r	r ₂	D ₂ Max	f Max	a Max	b Min	Dynamic Cr	Static Cor		oil	grease
6011	2.1654	.0006	3.5433	.0006	.7087	.0059	.043	.020	3.799	.097	.113	.106	6,350	4,770	.855	9,000	7,700
	.55	.015	.90	.015	.18	.150	1.1	.5	96.5	2.46	2.87	2.7	28,300	21,200	.388		
6012	2.3622	.0006	3.7402	.0006	.7087	.0059	.043	.020	4.000	.097	.113	.106	6,637	5,220	.913	8,300	7,000
	.60	.015	.95	.015	.18	.150	1.1	.5	101.6	2.46	2.87	2.7	29,500	23,200	.414		
6013	2.5591	.0006	3.9370	.0006	.7087	.0059	.043	.020	4.193	.097	.113	.106	6,850	5,670	.968	7,700	6,500
	.65	.015	1.00	.015	.18	.150	1.1	.5	106.5	2.46	2.87	2.7	30,500	25,200	.439		
6014	2.7559	.0006	4.3307	.0006	.7874	.0059	.043	.020	4.591	.097	.113	.106	8,550	6,975	1.340	7,100	6,100
	.70	.015	1.10	.015	.20	.150	1.1	.5	116.6	2.46	2.87	2.7	38,000	31,000	.608		
6015	2.9528	.0006	4.5276	.0006	.7874	.0059	.043	.020	4.787	.097	.113	.106	8,890	7,537	1.431	6,700	5,700
	.75	.015	1.15	.015	.20	.150	1.1	.5	121.6	2.46	2.87	2.7	39,500	33,500	.649		
6016	3.1496	.0005	4.9213	.0007	.8661	.0059	.043	.020	5.303	.111	.113	.122	10,700	9,000	1.922	6,200	5,300
	.80	.015	1.25	.018	.22	.150	1.1	.5	134.7	2.82	2.87	3.1	47,500	40,000	.872		
6017	3.3465	.0008	5.1181	.0007	.8661	.0079	.043	.020	5.500	.111	.113	.122	11,137	9,675	2.024	5,900	5,000
	.85	.020	1.30	.018	.22	.200	1.1	.5	139.7	2.82	2.87	3.1	49,500	43,000	.918		
6018	3.5433	.0008	5.5118	.0007	.9449	.0079	.059	.020	5.894	.111	.146	.122	13,050	11,250	2.624	5,600	4,700
	.90	.020	1.40	.018	.24	.200	1.5	.5	149.7	2.82	3.71	3.1	58,000	50,000	1.190		
6019	3.7402	.0008	5.7087	.0007	.9449	.0079	.059	.020	6.091	.111	.146	.122	13,600	12,150	2.712	5,300	4,500
	.95	.020	1.45	.018	.24	.200	1.5	.5	154.7	2.82	3.71	3.1	60,500	54,000	1.230		
6020	3.9370	.0008	5.9055	.0007	.9449	.0079	.059	.020	6.287	.111	.146	.122	13,500	12,150	2.844	5,000	4,200
	1.00	.020	1.50	.018	.24	.200	1.5	.5	159.7	2.82	3.71	3.1	60,000	54,000	1.290		
6021	4.1339	.0008	6.2992	.0010	1.0236	.0079	.079	.020	6.681	.111	.146	.122	16,300	14,8050	3.510	4,700	4,000
	1.05	.020	1.60	.025	.26	.200	2.0	.5	169.7	2.82	3.71	3.1	72,500	66,000	1.592		
6022	4.3307	.0008	6.6929	.0010	1.1024	.0079	.079	.020	7.201	.122	.146	.138	19,125	16,400	4.321	4,500	3,800
	1.10	.020	1.70	.025	.28	.200	2.0	.5	182.9	3.1	3.71	3.5	85,000	73,000	1.960		
6024	4.7244	.0008	7.0866	.0010	1.1024	.0079	.079	.020	7.594	.122	.146	.138	19,800	18,000	4.586	4,100	3,500
	1.20	.020	1.80	.025	.28	.200	2.0	.5	192.9	3.1	3.71	3.5	88,000	80,000	2.080		
6026	5.1181	.0010	7.8740	.0012	1.2992	.0098	.079	.020	8.382	.122	.224	.138	23,850	22,700	7.187	3,800	3,200
	1.30	.025	2.00	.030	.33	.250	2.0	.5	212.9	3.1	5.69	3.5	106,000	101,000	3.260		
6028	5.5118	.0010	8.2677	.0012	1.2992	.0098	.079	.020	8.776	.122	.224	.138	24,750	24,525	7.672	3,500	3,000
	1.40	.025	2.10	.030	.33	.250	2.0	.5	222.9	3.1	5.69	3.5	110,000	109,000	3.480		
6030	5.9055	.0010	8.8583	.0012	1.3780	.0098	.083	.020	9.362	.122	.224	.138	28,350	28,350	9.348	3,200	2,800
	1.50	.025	2.25	.030	.35	.250	2.1	.5	237.8	3.1	5.69	3.5	126,000	126,000	4.240		
6032	6.2992	.0010	9.4488	.0012	1.4961	.0098	.083	.020	9.957	.122	.224	.138	32,175	32,400	11.354	3,000	2,600
	1.60	.025	2.40	.030	.38	.250	2.1	.5	252.9	3.1	5.69	3.5	143,000	144,000	5.150		
6034	6.6929	.0010	10.2362	.0014	1.6535	.0098	.083						37,800	38,700	15.190	2,800	2,400
	1.70	.025	2.60	.035	.42	.250	2.1						168,000	172,000	6.890		
6036	7.0866	.0010	11.0236	.0014	1.8110	.0098	.083						42,500	44,775	19.400	2,700	2,300
	1.80	.025	2.80	.035	.46	.250	2.1						189,000	199,000	8.800		
6038	7.4803	.0012	11.4173	.0014	1.8110	.0118	.083						44,325	48,375	20.701	2,500	2,100
	1.90	.030	2.90	.035	.46	.300	2.1						197,000	215,000	9.390		
6040	7.8740	.0012	12.2047	.0014	2.0079	.0118	.083						49,050	54,675	26.455	2,400	2,000
	2.00	.030	3.10	.035	.51	.300	2.1						218,000	243,000	12.000		

*Maximum fillet which corner radius of bearing will clear.

This deep groove, Conrad construction bearing is specifically designed to provide maximum performance by means of precise ball complement selection. The honed raceways offer a perfectly balanced bearing capable of operating under straight radial, thrust or combination loads. This series is available with shields, Buna N seals, or locating rings. Sealed bearings may be obtained with either low or high starting torques. Consult Peer's engineering staff for proper selection. Stainless steel 440C material is available upon request. Radial clearance is selected in accordance with applications ranging from C2 - C0 - C3 - C4 fits.

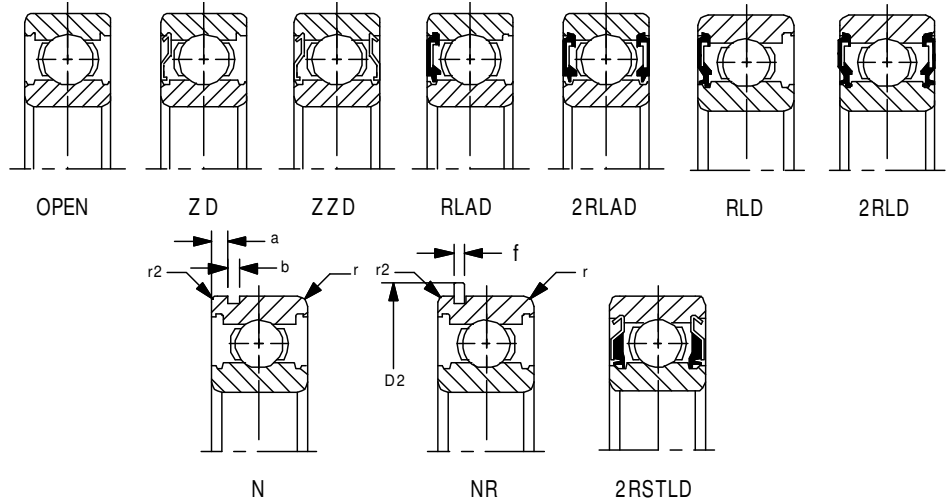
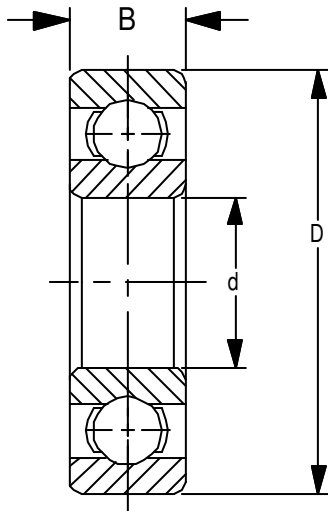

Units: Inches
Metric

Part Number	Bore d	Tolerance +.0000 to minus	OD D	Tolerance +.0000 to minus	Width B	Tolerance +.0000 to minus	* fillet radii		snap ring dimensions		snap ring groove dimensions		Basic Load Ratings lbf N		Weight lb Kg	Limiting speed of Open Bearing (rpm)	
							r	r2	D2 Max	f Max	a Max	b Min	Dynamic Cr	Static Cor		oil	grease
6200	.3937	.0003	1.1811	.0004	.3543	.0047	.024	.020	1.366	.044	.081	.053	1,150	540	.071	30,000	25,000
	10	.008	30	.009	9	.120	.6	.5	34.7	1.12	2.06	1.35	5,100	2,390	.032		
6201	.4724	.0003	1.2598	.0005	.3937	.0047	.024	.020	1.445	.044	.081	.053	1,530	680	.082	26,000	22,000
	12	.008	32	.011	10	.120	.6	.5	36.7	1.12	2.06	1.35	6,800	3,050	.037		
6201-8	.5000	.0003	1.2598	.0005	.3937	.0047	.024	.020	1.445	.044	.081	.053	1,530	680	.082	26,000	22,000
	12.7	.008	32	.011	10	.120	.6	.5	36.7	1.12	2.06	1.35	6,800	3,050	.037		
6201-13mm	.5118	.0003	1.2598	.0005	.3937	.0047	.024	.020	1.445	.044	.081	.053	1,530	680	.090	26,000	22,000
	13	.008	32	.011	10	.120	.6	.5	36.7	1.12	2.06	1.35	6,800	3,050	.041		
6202	.5906	.0003	1.3780	.0005	.4331	.0047	.024	.020	1.563	.044	.081	.053	1,740	839	.110	26,000	20,000
	15	.008	35	.011	11	.120	.6	.5	39.7	1.12	2.06	1.35	7,740	3,732	.050		
6202-10	.6250	.0003	1.3780	.0005	.4331	.0047	.024	.020	1.563	.044	.081	.053	1,740	839	.110	26,000	20,000
	15.875	.008	35	.011	11	.120	.6	.5	39.7	1.12	2.06	1.35	7,740	3,732	.050		
99502H	.6250	.0003	1.375	.0005	.4331	.0047	.024	.020	1.563	.044	.081	.053	1,740	839	.110	26,000	20,000
	15.875	.008	34.93	.011	11	.120	.6	.5	39.7	1.12	2.06	1.35	7,740	3,732	.050		
499502H	.6250	.0003	1.375	.0005	.4331	.0047	.024	.020	1.563	.044	.081	.053	1,740	839	.110	26,000	20,000
	15.875	.008	34.93	.011	11	.120	.6	.5	39.7	1.12	2.06	1.35	7,740	3,732	.050		
6202-16mm	.6299	.0003	1.3780	.0005	.4331	.0047	.024	.020	1.563	.044	.081	.053	1,740	839	.110	26,000	20,000
	16	.008	35	.011	11	.120	.6	.5	39.7	1.12	2.06	1.35	7,740	3,732	.050		
6203	.6693	.0003	1.5748	.0005	.4724	.0047	.024	.020	1.756	.044	.081	.053	2,160	1,080	.150	21,000	18,000
	17	.008	40	.011	12	.120	.6	.5	44.6	1.12	2.06	1.35	9,600	4,800	.068		
6203-6	.3750	.0003	1.5748	.0005	.4724	.0047	.024	.020	1.756	.044	.081	.053	2,160	1,080	.150	21,000	18,000
	9.525	.008	40	.011	12	.120	.6	.5	44.6	1.12	2.06	1.35	9,600	4,800	.068		
6203-8	.5000	.0003	1.5748	.0005	.4724	.0047	.024	.020	1.756	.044	.081	.053	2,150	1,080	.150	21,000	18,000
	12.7	.008	40	.011	12	.120	.6	.5	44.6	1.12	2.06	1.35	9,600	4,800	.068		
6203-10	.6250	.0003	1.5748	.0005	.4724	.0047	.024	.020	1.756	.044	.081	.053	2,150	1,080	.150	21,000	18,000
	15.875	.008	40	.011	12	.120	.6	.5	44.6	1.12	2.06	1.35	9,600	4,800	.068		
6203-16mm	.6299	.0003	1.5748	.0005	.4724	.0047	.024	.020	1.756	.044	.081	.053	2,150	1,080	.150	21,000	18,000
	16	.008	40	.011	12	.120	.6	.5	44.6	1.12	2.06	1.35	9,600	4,800	.068		

*Maximum fillet which corner radius of bearing will clear.



6200 SERIES (continued)

This deep groove, Conrad construction bearing is specifically designed to provide maximum performance by means of precise ball complement selection. The honed raceways offer a perfectly balanced bearing capable of operating under straight radial, thrust or combination loads. This series is available with shields, Buna N seals, or locating rings. Sealed bearings may be obtained with either low or high starting torques. Consult Peer's engineering staff for proper selection. Stainless steel 440C material is available upon request. Radial clearance is selected in accordance with applications ranging from C2 - C0 - C3 - C4 fits.

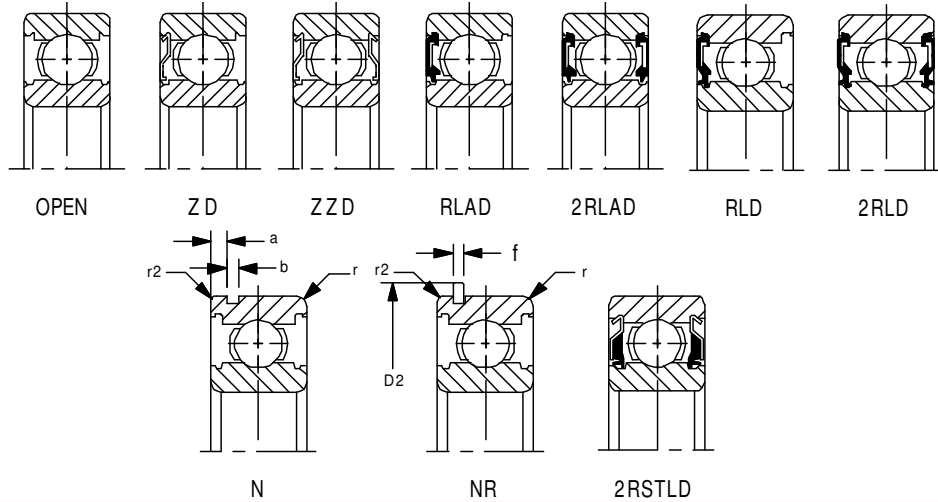
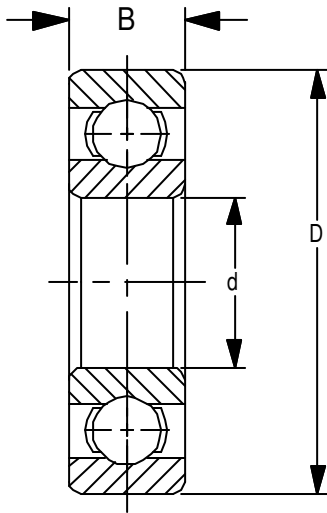

Units: Inches Metric

Part Number	Bore d	Tolerance +.0000 to minus	OD D	Tolerance +.0000 to minus	Width B	Tolerance +.0000 to minus	* fillet radii		snap ring dimensions		snap ring groove dimensions		Basic Load Ratings		Weight lb Kg	Limiting speed of Open Bearing (rpm)	
							r	r ₂	D ₂ Max	f Max	a Max	b Min	Dynamic Cr	Static Cor		oil	grease
6203-12	.7500	.0003	1.5748	.0005	.4724	.0047	.024	.020	1.756	.044	.081	.053	2,150	1,080	.150	21,000	18,000
	19.05	.008	40	.011	12	.120	.6	.5	44.6	1.12	2.06	1.35	9,600	4,800	.068		
6204	.7874	.0004	1.8504	.0005	.5512	.0047	.039	.020	2.075	.044	.097	.053	2,880	1,480	.236	18,000	16,000
	20	.010	47	.011	14	.120	1.0	.5	52.7	1.12	2.46	1.35	12,811	6,580	.107		
6204-12	.7500	.0004	1.8504	.0005	.5512	.0047	.039	.020	2.075	.044	.097	.053	2,880	1,480	.236	18,000	16,000
	19.05	.010	47	.011	14	.120	1.0	.5	52.7	1.12	2.46	1.35	12,811	6,580	.107		
6204-14	.8750	.0004	1.8504	.0005	.5512	.0047	.039	.020	2.075	.044	.097	.053	2,880	1,480	.236	18,000	16,000
	22.225	.010	47	.011	14	.120	1.0	.5	52.7	1.12	2.46	1.35	12,811	6,580	.107		
Z9504-2RST	.7504	.0004	1.7805	.0005	.6100	.0047	.039	.020					2,880	1,480	.249	18,000	16,000
	19.016	.010	45.22	.011	15.49	.120	1.0	.5					12,811	6,580	.113		
62/22	.8661	.0004	1.9685	.0005	.5512	.0047	.059	.020	2.193	.044	.097	.053	2,900	1,530	.262	17,000	14,000
	22	.010	50	.011	14	.120	1.0	.5	55.7	1.12	2.46	1.35	12,900	6,806	.119		
6205	.9843	.0004	2.0472	.0005	.5906	.0047	.039	.020	2.280	.044	.097	.053	3,150	1,770	.284	15,000	13,000
	25	.010	52	.013	15	.120	1.0	.5	57.9	1.12	2.46	1.35	14,000	7,850	.129		
6205-14	.8750	.0004	2.0472	.0005	.5906	.0047	.039	.020	2.280	.044	.097	.053	3,150	1,770	.284	15,000	13,000
	22.225	.010	52	.013	15	.120	1.0	.5	57.9	1.12	2.46	1.35	14,000	7,850	.129		
6205-16	1.0000	.0004	2.0472	.0005	.5906	.0047	.039	.020	2.280	.044	.097	.053	3,150	1,770	.291	15,000	13,000
	25.4	.010	52	.013	15	.120	1.0	.5	57.9	1.12	2.46	1.35	14,000	7,850	.132		
62/28	1.1024	.0004	2.2835	.0005	.6299	.0047	.059	.020	2.508	.044	.097	.053	4,027	2,190	.386	14,000	12,000
	28	.010	58	.013	16	.120	1.5	.5	63.7	1.12	2.46	1.35	17,900	9,750	.175		
6206	1.1811	.0004	2.4409	.0005	.6299	.0047	.039	.020	2.665	.067	.129	.075	4,400	2,540	.262	13,000	11,000
	30	.010	62	.013	16	.120	1.0	.5	67.7	1.7	3.28	1.9	19,500	11,300	.119		
62/32	1.2598	.0005	2.5591	.0005	.6693	.0047	.059	.020	2.783	.067	.129	.075	4,657	2,600	.498	12,000	11,000
	32	.012	65	.013	17	.120	1.5	.5	70.7	1.7	3.28	1.9	20,700	11,600	.226		
6207	1.3780	.0005	2.8346	.0005	.6693	.0047	.043	.020	3.094	.067	.129	.075	5,782	3,442	.626	11,000	9,300
	35	.012	72	.013	17	.120	1.1	.5	78.6	1.7	3.28	1.9	25,700	15,300	.284		
6208	1.5748	.0005	3.1496	.0005	.7087	.0047	.043	.020	3.409	.067	.129	.075	6,550	4,000	.807	10,000	8,700
	40	.012	80	.013	18	.120	1.1	.5	86.6	1.7	3.28	1.9	29,100	17,900	.366		
6209	1.7717	.0005	3.3465	.0006	.7480	.0047	.043	.020	3.606	.067	.129	.075	7,350	4,580	.939	9,200	7,800
	45	.012	85	.015	19	.120	1.1	.5	91.6	1.7	3.28	1.9	32,700	20,400	.426		

*Maximum fillet which corner radius of bearing will clear.

6200 SERIES (continued)

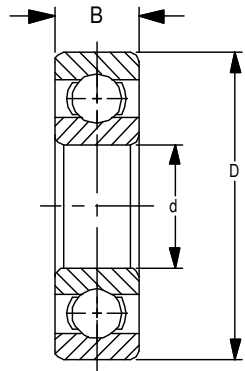

This deep groove, Conrad construction bearing is specifically designed to provide maximum performance by means of precise ball complement selection. The honed raceways offer a perfectly balanced bearing capable of operating under straight radial, thrust or combination loads. This series is available with shields, Buna N seals, or locating rings. Sealed bearings may be obtained with either low or high starting torques. Consult Peer's engineering staff for proper selection. Stainless steel 440C material is available upon request. Radial clearance is selected in accordance with applications ranging from C2 - C0 - C3 - C4 fits.

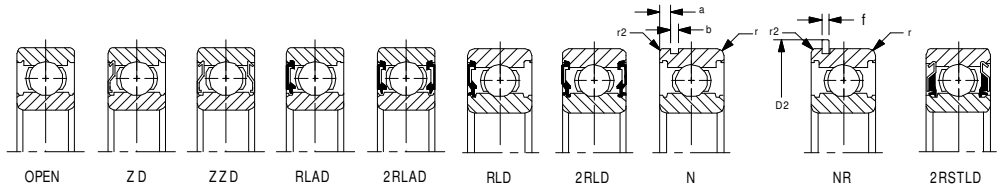

Units: Inches Metric

Part Number	Bore d	Tolerance +.0000 to minus	OD D	Tolerance +.0000 to minus	Width B	Tolerance +.0000 to minus	* fillet radii		snap ring dimensions		snap ring groove dimensions		Basic Load Ratings lbf N		Weight lb Kg	Limiting speed of Open Bearing (rpm)	
							r	r2	D2 Max	f Max	a Max	b Min	Dynamic Cr	Static Cor		oil	grease
6210	1.9685	.0005	3.5433	.0006	.7874	.0047	.043	.020	3.799	.097	.129	.106	7,875	5,220	1.012	8,300	7,100
	50	.012	90	.015	20	.120	1.1	.5	96.5	2.46	3.28	2.7	35,000	23,200	.459		
6211	2.1654	.0006	3.9370	.0006	.8268	.0059	.059	.020	4.193	.097	.129	.106	9,800	6,580	1.365	7,600	6,400
	55	.015	100	.015	21	.150	1.5	.5	106.5	2.46	3.28	2.7	43,500	29,300	.619		
6212	2.3622	.0006	4.3307	.0006	.8661	.0059	.059	.020	4.591	.097	.129	.106	11,800	8,100	1.720	7,000	6,000
	60	.015	110	.015	22	.150	1.5	.5	116.6	2.46	3.28	2.7	52,500	36,000	.780		
6213	2.5591	.0006	4.7244	.0006	.9055	.0059	.059	.020	5.106	.111	.160	.122	12,937	9,037	2.220	6,500	5,500
	65	.015	120	.015	23	.150	1.5	.5	129.7	2.82	4.06	3.1	57,500	40,000	1.007		
6214	2.7559	.0006	4.9213	.0007	.9449	.0059	.059	.020	5.303	.111	.160	.122	13,950	9,900	2.410	6,000	5,100
	70	.015	125	.018	24	.150	1.5	.5	134.7	2.82	4.06	3.1	62,000	44,000	1.093		
6215	2.9528	.0006	4.1181	.0007	.9843	.0059	.059	.020	5.500	.111	.160	.122	14,900	11,100	2.620	5,600	4,800
	75	.015	130	.018	25	.150	1.5	.5	139.7	2.82	4.06	3.1	66,000	49,500	1.190		
6216	3.1496	.0006	5.5118	.0007	1.0236	.0059	.079	.020	5.894	.111	.193	.122	16,300	11,925	3.130	5,300	4,500
	80	.015	140	.018	26	.150	2.0	.5	149.7	2.82	4.9	3.1	72,500	53,000	1.420		
6217	3.3465	.0008	5.9055	.0007	1.1024	.0079	.079	.020	6.287	.111	.193	.122	18,787	14,400	3.880	5,000	4,200
	85	.020	150	.018	28	.200	2.0	.5	159.7	2.82	4.9	3.1	83,500	64,000	1.760		
6218	3.5433	.0008	6.2992	.0010	1.1811	.0079	.079	.020	6.681	.111	.193	.122	21,000	16,100	4.800	4,700	4,000
	90	.020	160	.025	30	.200	2.0	.5	167.7	2.82	4.9	3.1	96,000	71,500	2.180		
6219	3.7402	.0008	6.6929	.0010	1.2598	.0079	.083	.020	7.201	.122	.224	.138	24,525	18,450	5.820	4,400	3,700
	95	.020	170	.025	32	.200	2.1	.5	182.9	3.1	5.69	3.5	109,000	82,000	2.640		
6220	3.9370	.0008	7.0866	.0010	1.3386	.0079	.083	.020	7.594	.122	.224	.138	27,500	20,900	7.200	4,200	3,500
	100	.020	180	.025	.4	.200	2.1	.5	192.9	3.1	5.69	3.5	122,000	93,000	3.266		
6221	4.1339	.0008	7.4803	.0012	1.4173	.0079	.083	.020	7.988	.122	.224	.138	29,900	23,500	8.350	4,000	3,400
	105	.020	190	.030	36	.200	2.1	.5	202.9	3.1	5.69	3.5	133,000	105,000	3.790		
6222	4.3307	.0008	7.8740	.0012	1.4961	.0079	.083	.020	8.382	.122	.224	.138	32,400	26,325	9.810	3,800	3,200
	110	.020	200	.030	38	.200	2.1	.5	212.9	3.1	5.69	3.5	144,500	117,000	4.450		
6224	4.7244	.0008	7.4646	.0012	1.5748	.0079	.083						34,875	29,475	11.660	3,400	2,900
	120	.020	215	.030	40	.200	2.1						155,000	131,000	5.290		
6226	5.1181	.0010	9.0551	.0012	1.5748	.0098	.118						37,575	32,850	13.140	3,100	2,700
	130	.025	230	.030	40	.250	3.0						167,000	146,000	5.960		
6228	5.5118	.0010	9.8425	.0012	1.6535	.0098	.118						37,350	33,500	16.900	2,900	2,500
	140	.025	250	.030	42	.250	3.0						166,000	149,750	7.566		
6230	5.9055	.0010	1.6299	.0014	1.7717	.0098	.118						39,600	37,500	22.050	2,700	2,300
	150	.025	270	.035	45	.250	3.0						175,600	150,000	10.002		
6232	6.2992	.0010	11.4173	.0014	1.8898	.0098	.118						41,625	42,800	28.200	2,500	2,100
	160	.025	290	.035	48	.250	3.0						185,000	186,000	12.800		
6234	6.6929	.0010	12.2047	.0014	2.0472	.0098	.157						47,700	50,400	34.800	2,400	2,000
	170	.025	310	.035	52	.250	4.0						212,000	224,000	15.785		
6236	7.0866	.0010	12.5984	.0016	2.0472	.0098	.157						51,075	54,225	34.800	2,200	1,900
	180	.025	320	.040	52	.250	4.0						227,000	241,000	15.785		
6238	7.4803	.0012	13.3858	.0016	2.1654	.0118	.157						57,335	63,450	49.170	2,100	1,800
	190	.030	340	.040	55	.300	4.0						255,000	282,000	22.303		

*Maximum fillet which corner radius of bearing will clear.



6300 SERIES

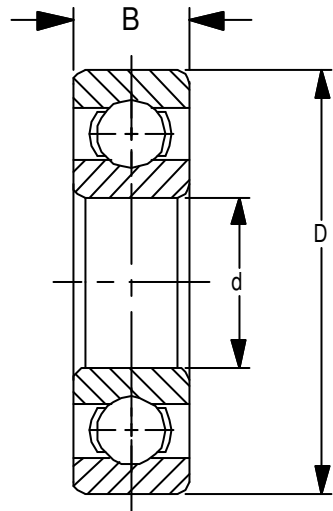

Similar in function to the 6200 series. Produced with larger ball complement enabling the bearing to withstand greater radial and thrust for a given bore size. This series is available with shields, Buna N seals, or locating rings. Sealed bearings may be obtained with either low or high starting torques. Consult Peer's engineering staff for proper selection. Stainless steel 440C material is available upon request. Radial clearance is selected in accordance with applications ranging from C2 - C0 - C3 - C4 fits.

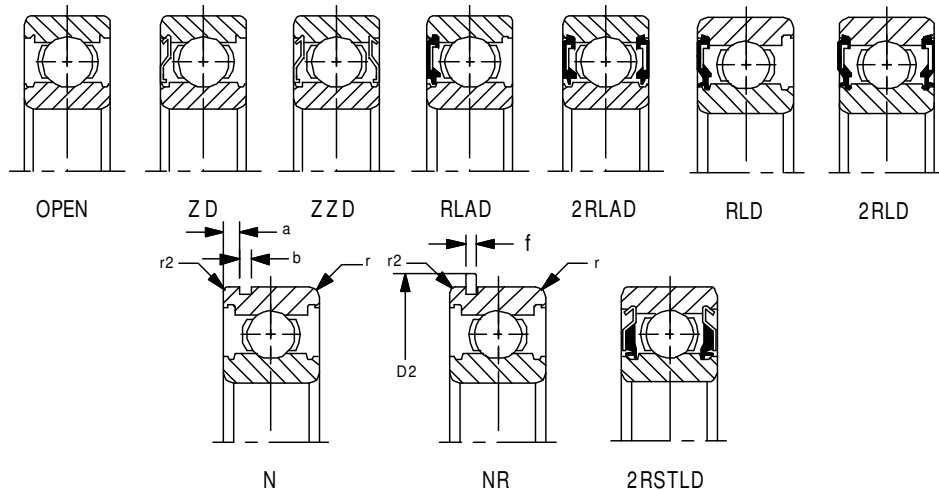

Units: Inches
Metric

Part Number	Bore d	Tolerance +.0000 to minus	OD D	Tolerance +.0000 to minus	Width B	Tolerance +.0000 to minus	* fillet radii		snap ring dimensions		snap ring groove dimensions		Basic Load Ratings lbf N		Weight lb Kg	Limiting speed of Open Bearing (rpm)	
							r	r ₂	D ₂ Max	f Max	a Max	b Min	Dynamic Cr	Static Cor		oil	grease
6300	.3937	.0003	1.3780	.0005	.4331	.0047	.024	.020	1.563	.044	.081	.053	1,845	785	.110	27,000	23,000
	10	.008	35	.011	11	.120	.6	.5	39.7	1.12	2.06	1.35	8,200	3,500	.050		
6301	.4724	.0003	1.4567	.0005	.4724	.0047	.039	.020	1.626	.044	.081	.053	2,180	940	.132	24,000	20,000
	12	.008	37	.011	12	.120	1.0	.5	41.3	1.12	2.06	1.35	9,700	4,200	.056		
6302	.5906	.0003	1.6535	.0005	.5118	.0047	.039	.020	1.823	.044	.081	.053	2,570	1,220	.150	21,000	17,000
	15	.008	42	.011	13	.120	1.0	.5	46.3	1.12	2.06	1.35	11,400	5,450	.068		
6303	.6693	.0003	1.8504	.0005	.5512	.0047	.039	.020	2.075	.044	.097	.053	3,060	1,470	.249	19,000	16,000
	17	.008	47	.011	14	.120	1.0	.5	52.7	1.12	2.46	1.35	13,600	6,650	.113		
6304	.7874	.0004	1.0472	.0005	.5906	.0047	.043	.020	2.280	.044	.097	.053	3,600	1,770	.319	17,000	14,000
	20	.010	52	.013	15	.120	1.1	.5	57.9	1.12	2.46	1.35	15,900	7,900	.145		
63/22	.8661	.0004	2.2047	.0005	.6299	.0047	.043	.020	2.429	.044	.097	.053	4,140	2,080	.394	15,000	13,000
	22	.010	56	.013	16	.120	1.1	.5	61.7	1.12	2.46	1.35	18,400	9,250	.179		
6305	.9843	.0004	2.4409	.0005	.6693	.0047	.043	.020	2.665	.067	.129	.075	4,750	2,460	.518	14,000	12,000
	25	.010	62	.013	17	.120	1.1	.5	67.7	1.7	3.28	1.9	21,200	11,200	.235		
63/28	1.1024	.0004	2.6772	.0005	.7087	.0047	.043	.020	2.937	.067	.129	.075	6,000	3,150	.633	13,000	11,000
	28	.010	68	.013	18	.120	1.1	.5	74.6	1.7	3.28	1.9	26,700	14,000	.287		
6306	1.1811	.0004	2.8346	.0005	.7480	.0047	.043	.020	3.094	.067	.129	.075	6,000	3,375	.760	12,000	10,000
	30	.010	72	.013	19	.120	1.1	.5	78.6	1.7	3.28	1.9	26,700	15,000	.345		
63/32	1.2598	.0005	2.9528	.0005	.7874	.0047	.043	.020	3.213	.067	.129	.075	6,727	3,825	.857	11,000	9,500
	32	.012	75	.013	20	.120	1.1	.5	81.6	1.7	3.28	1.9	29,900	17,000	.389		
6307	1.3780	.0005	3.1496	.0005	.8268	.0047	.059	.020	3.409	.067	.129	.075	7,537	4,320	1.030	10,000	8,800
	35	.012	80	.013	21	.120	1.5	.5	86.6	1.7	3.28	1.9	33,500	19,200	.464		
6308	1.5748	.0005	3.5433	.0006	.9055	.0047	.059	.020	3.799	.097	.129	.106	9,112	5,400	1.410	9,200	7,800
	40	.012	90	.015	23	.120	1.5	.5	96.5	2.46	3.28	2.7	40,500	24,000	.640		
6309	1.7717	.0005	3.9370	.0006	.9843	.0047	.059	.020	4.193	.097	.129	.106	11,925	7,200	1.82	8,200	7,000
	45	.012	100	.015	25	.120	1.5	.5	106.5	2.46	3.28	2.7	53,000	32,000	.829		

*Maximum fillet which corner radius of bearing will clear.

6300 SERIES (continued)

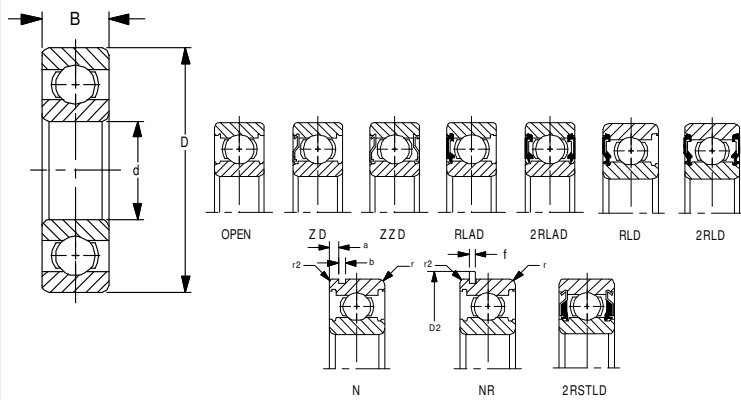

Similar in function to the 6200 series. Produced with larger ball complement enabling the bearing to withstand greater radial and thrust for a given bore size. This series is available with shields, Buna N seals, or locating rings. Sealed bearings may be obtained with either low or high starting torques. Consult Peer's engineering staff for proper selection. Stainless steel 440C material is available upon request. Radial clearance is selected in accordance with applications ranging from C2 - C0 - C3 - C4 fits.

Units: Inches
Metric

Part Number	Bore d	Tolerance +.0000 to minus	OD D	Tolerance +.0000 to minus	Width B	Tolerance +.0000 to minus	* fillet radii		snap ring dimensions		snap ring groove dimensions		Basic Load Ratings lbf N		Weight lb Kg	Limiting speed of Open Bearing (rpm)	
							r	r2	D2 Max	f Max	a Max	b Min	Dynamic Cr	Static Cor		oil	grease
6310	1.9685	.0005	4.3307	.0006	1.0630	.0047	.079	.020	4.591	.097	.129	.106	13,950	8,600	2.470	7,500	6,400
	50	.012	110	.015	27	.120	2.0	.5	116.6	2.46	3.28	2.7	62,000	38,500	1.120		
6311	2.1654	.0006	4.7244	.0006	1.1417	.0059	.079	.020	5.106	.111	.160	.122	16,100	10,125	3.070	6,800	5,800
	55	.015	120	.015	29	.150	2.0	.5	129.7	2.82	4.06	3.1	71,500	45,000	1.393		
6312	2.3622	.0006	5.1181	.0007	1.2205	.0059	.079	.020	5.500	.111	.160	.122	18,450	11,700	3.810	6,300	5,400
	60	.015	130	.018	31	.150	2.1	.5	139.7	2.82	4.06	3.1	82,000	52,000	1.728		
6313	2.5591	.0006	5.5118	.0007	1.2992	.0059	.079	.020	5.894	.111	.193	.122	20,800	13,500	4.700	5,800	4,900
	65	.015	140	.018	33	.150	2.1	.5	149.7	2.82	4.9	3.1	92,500	60,000	2.110		
6314	2.7559	.0006	5.9055	.0007	1.3780	.0059	.079	.020	6.287	.111	.193	.122	23,400	15,300	5.720	5,400	4,600
	70	.015	150	.018	35	.150	2.1	.5	159.7	2.82	4.9	3.1	104,000	68,000	2.595		
6315	2.9528	.0006	6.2992	.0010	1.4567	.0059	.079	.020	6.681	.111	.193	.122	25,425	17,325	8.37	5,000	4,300
	75	.015	160	.025	37	.150	2.1	.5	169.7	2.82	4.9	3.1	113,000	77,000	3.80		
6316	3.1496	.0006	6.6929	.0010	1.5354	.0059	.079	.020	7.201	.122	.224	.138	27,675	19,460	8.130	4,700	4,000
	80	.015	170	.025	39	.150	2.1	.5	182.9	3.1	5.69	3.5	123,000	86,500	3.688		
6317	3.3465	.0008	7.0866	.0012	1.6142	.0079	.118	.020	7.594	.122	.224	.138	29,925	21,825	9.73	4,500	3,800
	85	.020	180	.025	41	.200	3.0	.5	192.9	3.1	5.69	3.5	133,000	97,000	4.28		
6318	3.5433	.0008	7.4803	.0012	1.6929	.0079	.118	.020	7.988	.122	.224	.138	32,175	24,075	11.000	4,200	3,600
	90	.020	190	.030	43	.200	3.0	.5	202.9	3.1	5.69	3.5	143,000	107,000	4.990		
6319	3.7402	.0008	7.8740	.0012	1.7717	.0079	.118	.020	8.382	.122	.224	.138	34,425	26,775	12.800	3,900	3,300
	95	.020	200	.030	45	.200	3.0	.5	212.9	3.1	5.69	3.5	153,000	119,000	5.806		
6320	3.9370	.0008	8.4646	.0012	1.8504	.0079	.118	.020					38,925	31,725	15.52	3,700	3,200
	100	.020	215	.030	47	.200	3.0	.5					173,000	141,000	7.04		
6321	4.1339	.0008	8.8583	.0012	1.9291	.0079	.118	.020					41,400	34,650	18.300	3,600	3,000
	105	.020	225	.030	49	.200	3.0	.5					184,000	154,000	8.09		
6322	4.3307	.0008	9.4488	.0012	1.9685	.0079	.118	.020					46,125	40,275	20.9	3,400	2,900
	110	.020	240	.030	50	.200	3.0	.5					205,000	180,160	9.51		
6324	4.7244	.0008	10.2362	.0014	2.1654	.0079	.118	.020					46,575	41,625	27.56	3,100	2,600
	120	.020	260	.035	55	.200	3.0	.5					207,000	185,000	12.53		
6326	5.1181	.0010	11.0236	.0014	2.2835	.0098	.157	.020					51,525	48,150	33.700	2,800	2,400
	130	.025	280	.035	58	.250	4.0	.5					229,000	214,000	15.286		
6328	5.5118	.0010	11.8110	.0014	2.4409	.0098	.157	.020					56,925	55,350	40.800	2,600	2,200
	140	.025	300	.035	62	.250	4.0	.5					253,000	246,000	18.507		
6330	5.9055	.0010	12.5984	.0016	2.5591	.0098	.157	.020					61,500	63,900	50.05	2,400	2,100
	150	.025	320	.040	65	.120	4.0	.5					274,000	284,000	22.70		
6332	6.2992	.0010	13.3858	.0016	2.6772	.0098	.157	.020					62,550	64,575	57.77	2,300	1,900
	160	.025	340	.040	68	.120	4.0	.5					278,000	287,000	26.2		
6334	6.6929	.0010	14.1732	.0016	2.8346	.0098	.157	.020					73,125	79,875	80.7	2,100	1,800
	170	.025	360	.040	72	.120	4.0	.5					325,000	355,000	36.6		
6336	7.0866	.0012	14.9606	.0016	2.9528	.0098	.157	.020					79,875	91,150	95.63	2,000	1,700
	180	.025	380	.040	75	.120	4.0	.5					355,000	4075,000	8.10		
6338	7.4803	.0012	15.7480	.0016	3.0709	.0118	.197	.020					79,875	93,375	109.6	1,900	1,600
	190	.030	400	.040	78	.300	5.0	.5					355,000	415,000	49.7		
6340	7.8740	.0012	16.5354	.0018	3.1496	.0118	.197	.020					92,250	112,500	122.000	1,800	1,500
	200	.030	420	.045	80	.300	5.0	.5					410,000	500,000	55.339		

*Maximum fillet which corner radius of bearing will clear.



6400 SERIES

Similar to the 6200 and 6300 series offering various options such as shields, seals and locating rings. Manufactured with a larger ball size enabling the user to significantly increase the load using basically the same shaft parameters.

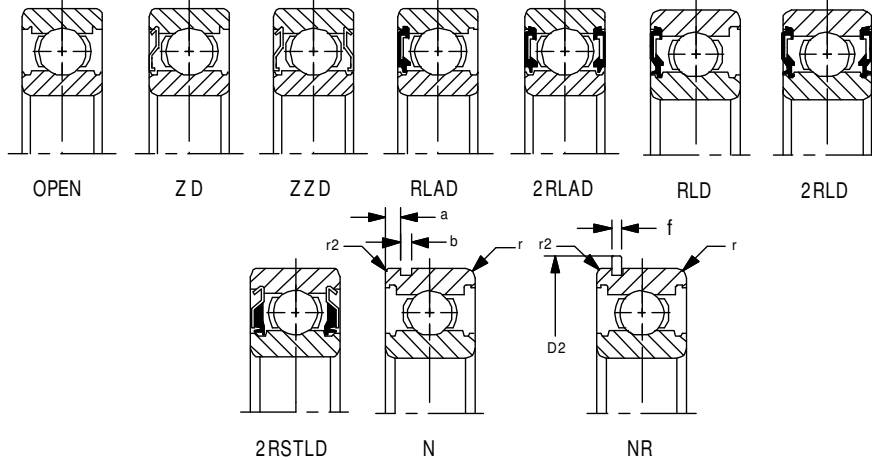
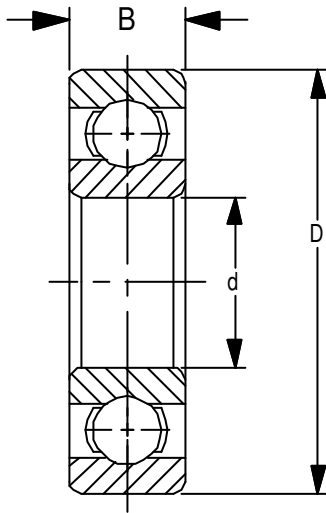

Units: Inches
Metric

Part Number	Bore d	Tolerance +.0000 to minus	OD D	Tolerance +.0000 to minus	Width B	Tolerance +.0000 to minus	* fillet radii		snap ring dimensions		snap ring groove dimensions		Basic Load Ratings lbf N		Weight lb Kg	Limiting speed of Open Bearing (rpm)	
							r	r2	D2 Max	f Max	a Max	b Min	Dynamic Cr	Static Cor		oil	grease
6403	.6693	.0003	2.4409	.0005	.6693	.0047	.043	.020	2.665	.067	.129	.075	5,300	2,500	.600	16,000	14,000
	17	.008	62	.013	17	.120	1.1	.5	67.7	1.7	3.28	1.9	23,574	11,120	.272		
6404	.7874	.0004	2.8346	.0005	.7480	.0047	.043	.020	3.091	.067	.129	.075	6,950	3,350	.900	14,000	12,000
	20	.010	72	.013	19	.120	1.1	.5	78.5	1.7	3.28	1.9	30,913	14,902	.408		
6405	.9843	.0004	3.1496	.0005	.8268	.0047	.059	.020	3.406	.067	.129	.075	8,150	4,300	1.220	12,000	10,000
	25	.010	80	.013	21	.120	1.5	.5	86.5	1.7	3.28	1.9	36,251	19,128	.553		
6406	1.1811	.0004	3.5433	.0006	.9055	.0047	.059	.020	3.800	.097	.129	.106	9,750	5,350	1.640	10,000	8,800
	30	.010	90	.015	23	.120	1.5	.5	96.5	2.46	3.28	2.7	43,368	23,796	.744		
6407	1.3780	.0005	3.9370	.0006	.9842	.0047	.059	.020	4.1933	.097	.129	.106	12,200	6,950	2.160	9,100	7,800
	35	.012	100	.015	25	.120	1.5	.5	106.5	2.46	3.28	2.7	54,270	30,913	.980		
6408	1.5748	.0005	4.3307	.0006	1.0630	.0047	.079	.020	4.57	.097	.129	.106	14,300	8,200	2.800	8,200	7,000
	40	.012	110	.015	27	.120	2.0	.5	116.5	2.46	3.28	2.7	63,612	36,477	1.270		
6409	1.7717	.0005	4.7244	.0006	1.1417	.0047	.079	.020	5.102	.111	.160	.122	17,300	10,200	3.480	7,400	6,300
	45	.012	120	.015	29	.120	2.0	.5	129.6	2.82	4.06	3.1	79,950	45,369	1.579		
6410	1.9685	.0005	5.1181	.0007	1.2205	.0047	.083	.020	5.496	.111	.160	.122	19,600	11,600	4.340	6,700	5,700
	50	.012	130	.018	31	.120	2.1	.5	139.6	2.82	4.06	3.1	87,180	51,596	1.970		
6411	2.1654	.0006	5.5118	.0007	1.2992	.0059	.083	.020	5.894	.111	.193	.122	22,400	14,000	5.250	6,100	5,200
	55	.015	140	.018	33	.150	2.1	.5	149.7	2.82	4.9	3.1	99,635	62,272	2.381		
6412	2.3622	.0006	5.9055	.0007	1.3780	.0059	.083	.020	6.287	.111	.193	.122	24,500	15,600	6.370	5,700	4,800
	60	.015	150	.018	35	.150	2.1	.5	159.7	2.82	4.9	3.1	108,976	69,388	2.890		
6413	2.5591	.0006	6.2992	.0010	1.4567	.0059	.083	.020	6.677	.122	.193	.122	26,500	17,600	7.580	5,200	4,400
	65	.015	160	.020	37	.150	2.1	.5	169.6	2.82	4.9	3.1	117,872	78,284	3.440		
6414	2.7559	.0006	7.0866	.0010	1.6535	.0059	.118	.020	7.594	.122	.224	.138	32,000	23,200	10.300	4,800	4,100
	70	.015	180	.020	42	.150	3.0	.5	192.9	3.1	5.69	3.5	142,349	103,193	4.672		
6415	2.9528	.0006	7.4803	.0012	1.7717	.0059	.118	.020	7.984	.122	.224	.138	34,500	25,500	15.000	4,500	3,800
	75	.015	190	.030	45	.150	3.0	.5	202.8	3.1	5.69	3.5	153,456	113,434	6.804		
6416	3.1496	.0006	7.8740	.0012	1.8898	.0059	.118	.020	8.382	.122	.224	.138	36,500	28,000	17.800	4,200	3,500
	80	.015	200	.030	48	.150	3.0	.5	212.9	3.1	5.69	3.5	162,367	124,544	8.074		
6417	3.3465	.0008	8.2677	.0012	2.0472	.0079	.157	.020	8.776	.122	.224	.138	39,000	30,500	21.000	4,000	3,400
	85	.020	210	.030	52	.200	4.0	.5	222.9	3.1	5.69	3.5	173,472	135,664	9.526		
6418	3.5433	.0008	8.8583	.0012	2.1260	.0079	.157	.020	9.362	.122	.224	.138	44,000	36,500	25.000	3,800	3,200
	90	.020	225	.030	54	.200	4.0	.5	237.8	3.1	5.69	3.5	195,712	162,352	11.340		

*Maximum fillet which corner radius of bearing will clear.

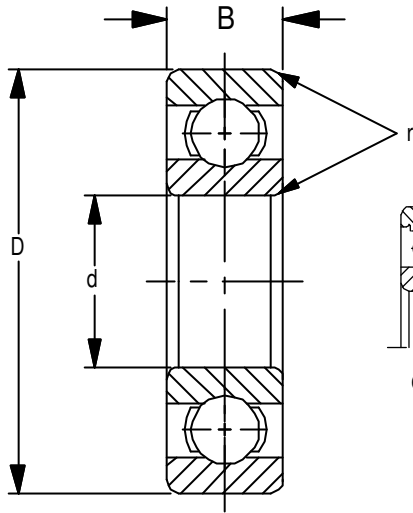

Designed to be dimensionally interchangeable with standard domestic inch series bearings. By using 52100 steel and holding dimensions to ABEC 1 tolerances, this series offers economy with electric motor quality. Close tolerance and improved ball complement allow an increased load capacity. This series is available with shields and seals. Consult the Peer sales engineer for availability.

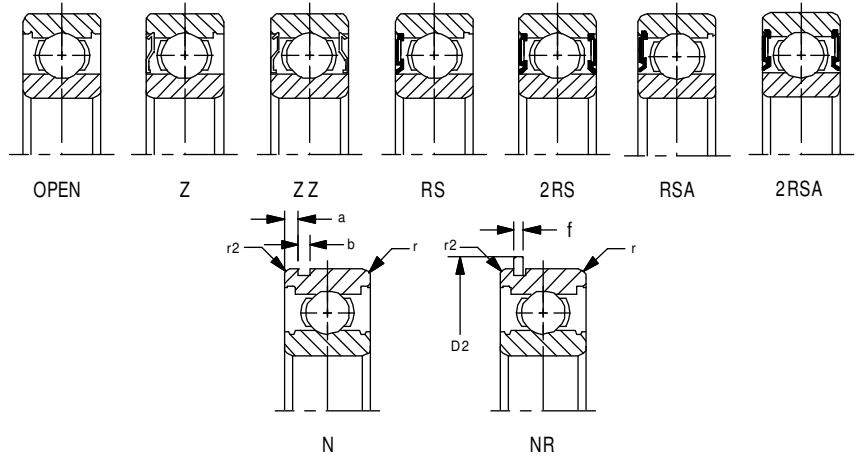

Units: Inches
Metric

Part Number	Bore d	Tolerance +.0000 to minus	OD D	Tolerance +.0000 to minus	Width (inch) (B)	Tolerance +.0000 to minus	* fillet radii r	Basic Load Ratings lbf N	
								Dynamic Cr	Static Cor
1601	3/16	.0010	1 1/16	.0005	1/4	.0050	.012	490	168
1602	.1875	.0005	.6875	.0005	†.2500	.0050	.012	2,180	748
	1/4		1 1/16		1/4			545	196
1603	.2500	.0005	.6875	.0005	†.2500	.0050	.012	2,424	872
	5/16		7/8		9/32			825	317
1604	.3125	.0005	.8750	.0005	††.2812	.0050	.015	3,670	1,411
	3/8		7/8		9/32			825	317
1605	.3750	.0005	.8750	.0005	††.2812	.0050	.012	3,670	1,411
	5/16		29/32		3/16			835	326
1606	.3125	.0005	.9062	.0005	.3125	.0050	.015	3,714	1,449
	3/8		29/32		5/16			835	326
1607	.3750	.0008	.9062	.0005	.3125	.0050	.015	3,714	1,449
	7/16		29/32		5/16			835	326
1614	.4375	.0005	.9062	.0005	.3125	.0050	.025	3,714	1,449
	3/8		1 1/8		3/8			1265	538
1615	.3750	.0005	1.1250	.0005	.3750	.0050	.025	5,627	2,392
	7/16		1 1/8		3/8			1265	538
1616	.4375	.0005	1.1250	.0005	.3750	.0050	.025	5,627	2,392
	1/2		1 1/8		3/8			1265	538
1620	.5000	.0005	1.1250	.0005	.3750	.0050	.025	5,627	2,392
	7/16		1 3/8		7/16			1890	836
1621	.4375	.0005	1.3750	.0005	.4375	.0050	.025	8,407	3,716
	1/2		1 3/8		7/16			1890	836
	.5000		1.3750		.4375			8,407	3,716

*Maximum fillet which corner radius of bearing will clear. †Width 5/16 for RS and 2RS types. ††Width 11/32 for RS and 2RS types.



1600 SERIES (continued)

Designed to be dimensionally interchangeable with standard domestic inch series bearings. By using 52100 steel and holding dimensions to ABEC 1 tolerances, this series offers economy with electric motor quality. Close tolerance and improved ball complement allow an increased load capacity. This series is available with shields and seals. Consult the Peer sales engineer for availability.

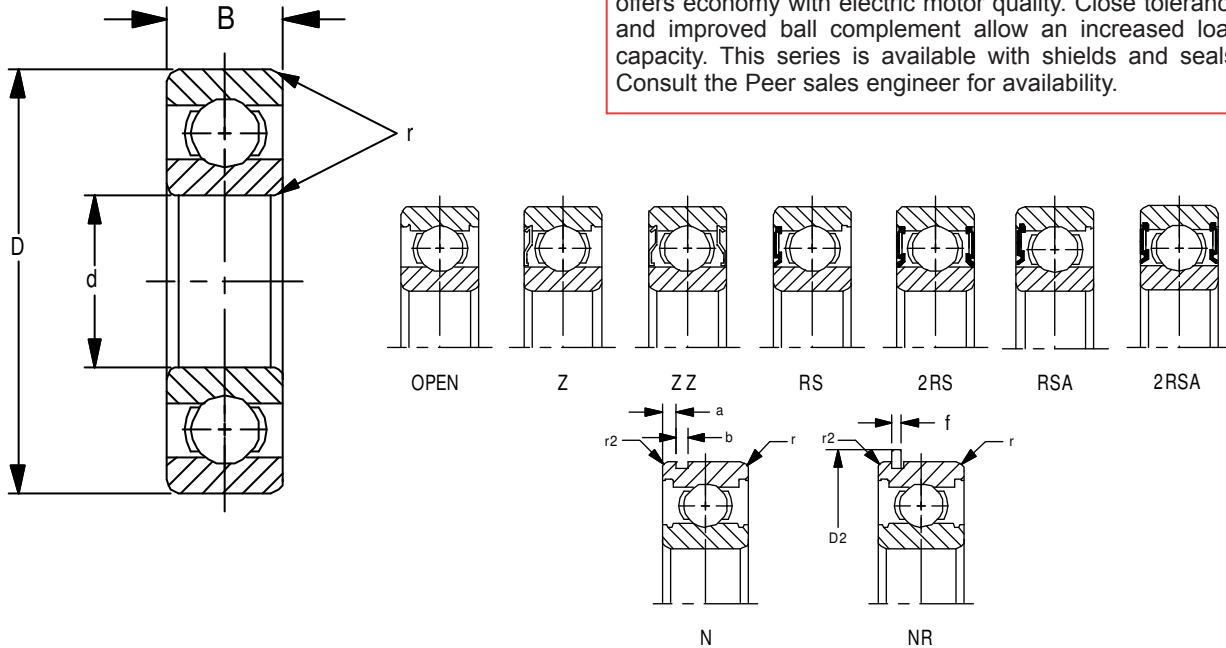

Units: Inches
Metric

Part Number	Bore d	Tolerance +.0000 to minus	OD D	Tolerance +.0000 to minus	Width (inch)	Tolerance +.0000 to minus	* fillet radii r	Basic Load Ratings	
								Dynamic Cr	Static Cor
1622	9/16	.0005	1 3/8	.0005	7/16	.0050	.025	1890	836
	.5625		1.3750		.4375			8,407	3,716
1623	5/8	.0005	1 3/8	.0005	7/16	.0050	.025	1890	836
	.6250		1.3750		.4375			8,407	3,716
1628	3/8	.0005	1 3/8	.0005	1/2	.0050	.025	2600	1010
	.6250		1.6250		.5000			11,564	4,492
1630	3/4	.0005	1 3/8	.0005	1/2	.0050	.025	2320	1117
	.7500		1.6250		.5000			10,320	4,966
1633	5/8	.0005	1 3/4	.0005	1/2	.0050	.025	2325	1142
	.6250		1.7500		.5000			10,343	5,079
1635	3/4	.0005	1 3/4	.0005	1/2	.0050	.025	2325	1142
	.7500		1.7500		.5000			10,343	5,079
1638	3/4	.0005	2	.0006	9/16	.0047	.035	2485	1338
	.7500		2.0000		.5625			11,054	5,952
1640	7/8	.0005	2	.0006	9/16	.0047	.035	2485	1338
	.8750		2.0000		.5625			11,054	5,952
1641	1	.0005	2	.0006	9/16	.0047	.035	3465	1752
	1.0000		2.0000		.5625			15,414	7,794
1652	1 1/8	.0005	2 1/2	.0006	5/8	.0047	.035	3955	2300
	1.1250		2.5000		.6250			17,593	10,231
1654	1 1/4	.0005	2 1/2	.0006	5/8	.0047	.035	3955	2300
	1.2500		2.5000		.6250			17,593	10,231
1657	1 1/4	.0005	2 9/16	.0006	11/16	.0047	.035	390	2317
	1.2500		2.5625		.6875			17,571	10,305
1658	1 5/16	.0005	2 9/16	.0006	11/16	.0047	.035	3950	2317
	1.3125		2.5625		.6875			17,571	10,305

*Maximum fillet which corner radius of bearing will clear.

W6200 CARTRIDGE SERIES

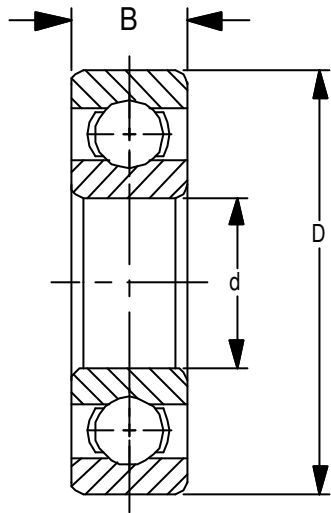

A basic 6200 bearing ball complement with wider widths. Used primarily in electric motors when extra grease storage is necessary. Will offer more shaft stability due to the extra width.

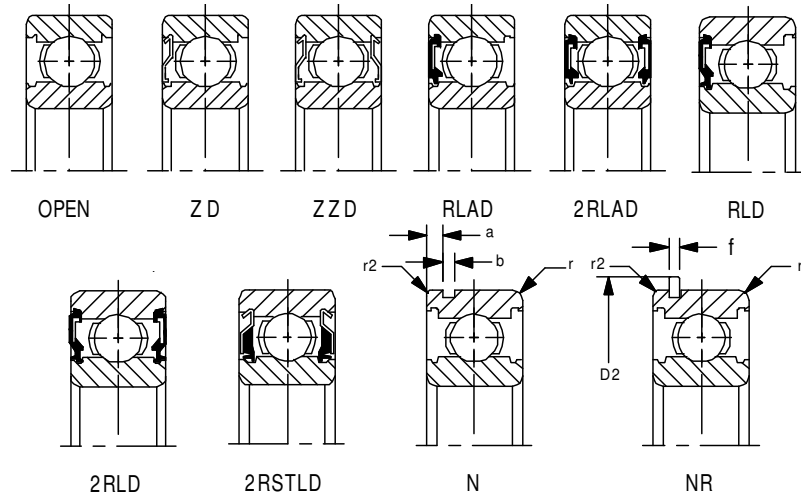

Units: Inches
Metric

Part Number	Bore d	Tolerance +.0000 to minus	OD D	Tolerance +.0000 to minus	Width B	Tolerance +.0000 to minus	* fillet radii		snap ring dimensions		snap ring groove dimensions		Basic Load Ratings lbf N		Weight lb Kg	Limiting speed of Open Bearing (rpm)	
							r	r2	D2 Max	f Max	a Max	b Min	Dynamic Cr	Static Cor		oil	grease
W6200	.3937	.0003	1.1811	.0004	.562	.0047	.024	.020	1.366	.044	.081	.053	1,150	540	.100	30,000	25,000
	10	.008	30	.009	14.27	.120	.6	.5	34.7	1.12	2.06	1.35	5,100	2,390	.045		
W6201	.4724	.0003	1.2598	.0005	.625	.0047	.024	.020	1.445	.044	.081	.053	1,530	680	.120	26,000	22,000
	12	.008	32	.011	15.58	.120	.6	.5	36.7	1.12	2.06	1.35	6,800	3,050	.054		
W6202	.5906	.0003	1.3780	.0005	.625	.0047	.024	.020	1.563	.044	.081	.053	1,740	839	.150	26,000	20,000
	15	.008	35	.011	15.58	.120	.6	.5	39.7	1.12	2.06	1.35	7,740	3,732	.068		
W6203	.6693	.0003	1.5748	.0005	.688	.0047	.024	.020	1.756	.044	.081	.053	2,160	1,080	.220	21,000	18,000
	17	.008	40	.011	17.48	.120	.6	.5	44.6	1.12	2.06	1.35	9,600	4,800	.100		
W6204	.7874	.0004	1.8504	.0005	.812	.0047	.039	.020	2.075	.044	.097	.053	2,880	1,480	.340	18,000	16,000
	20	.010	47	.011	20.62	.120	1.0	.5	52.7	1.12	2.46	1.35	12,811	6,580	.154		
W6205	.9743	.0004	2.0472	.0005	.812	.0047	.039	.020	2.280	.044	.097	.053	3,150	1,770	.390	15,000	13,000
	25	.010	52	.013	20.62	.120	1.0	.5	57.9	1.12	2.46	1.35	14,000	7,850	.177		
W6206	1.1811	.0004	2.4409	.0005	.938	.0047	.039	.020	2.665	.067	.129	.075	4,400	2,540	.630	13,000	11,000
	30	.010	62	.013	23.83	.120	1.0	.5	67.7	1.7	3.28	1.9	19,500	11,300	.286		
W6207	1.3780	.0005	2.8346	.0005	1.062	.0047	.043	.020	3.094	.067	.129	.075	5,782	3,442	.960	11,000	9,300
	35	.012	72	.013	26.97	.120	1.1	.5	78.6	1.7	3.28	1.9	25,700	15,300	.435		
W6208	1.5748	.0005	3.1496	.0005	1.188	.0047	.043	.020	3.409	.067	.129	.075	6,550	4,000	1.280	10,000	8,700
	40	.012	80	.013	30.18	.120	1.1	.5	86.6	1.7	3.28	1.9	29,100	17,900	.581		
W6209	1.7717	.0005	3.3465	.0006	1.188	.0047	.043	.020	3.606	.067	.129	.075	7,350	4,580	1.370	9,200	7,800
	45	.012	85	.015	30.1	.120	1.1	.5	91.6	1.7	3.28	1.9	32,700	20,400	.621		
W6210	1.9685	.0005	3.5433	.0006	1.188	.0047	.043	.020	3.799	.097	.129	.106	7,875	5,220	1.450	8,300	7,100
	50	.012	90	.015	30.18	.120	1.1	.5	96.5	2.46	3.28	2.7	35,000	23,200	.658		
W6211	2.1654	.0006	3.9370	.0006	1.311	.0059	.059	.020	4.193	.097	.129	.106	9,800	6,580	2.040	7,600	6,400
	55	.015	100	.015	33.30	.150	1.5	.5	106.5	2.46	3.28	2.7	43,500	29,300	.925		
W6212	2.3622	.0006	4.3307	.0006	1.437	.0059	.098	.020	4.591	.097	.129	.106	11,800	8,100	2.800	7,000	6,000
	60	.015	110	.015	36.50	.150	2.5	.5	116.6	2.46	3.28	2.7	52,500	36,000	1.270		

*Maximum fillet which corner radius of bearing will clear.



W6300 CARTRIDGE SERIES

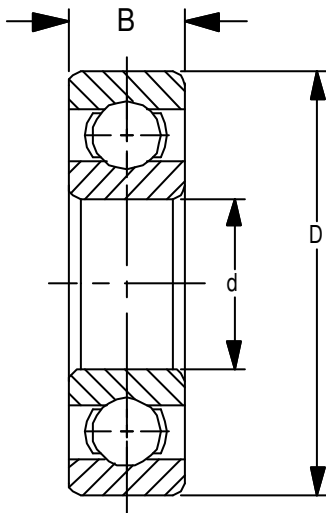

A basic 6300 bearing ball complement with wider widths. Having the same application as the W6200 series bearing.

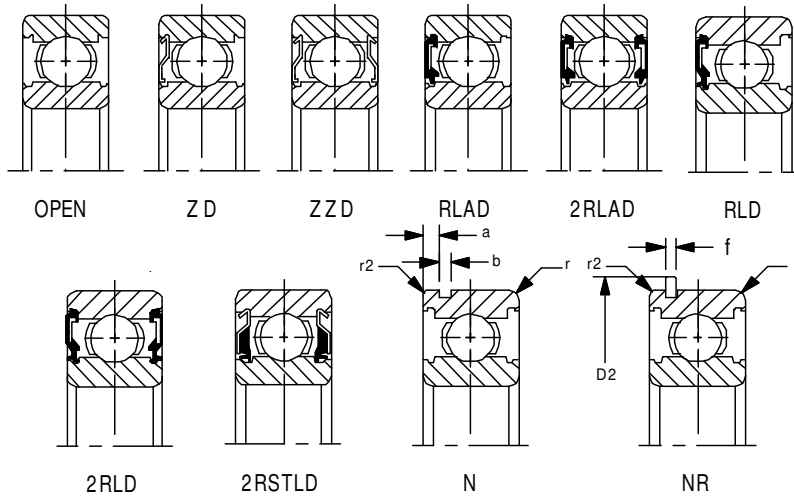

Units: Inches
Metric

Part Number	Bore d	Tolerance +.0000 to minus	OD D	Tolerance +.0000 to minus	Width B	Tolerance +.0000 to minus	* fillet radii		snap ring dimensions		snap ring groove dimensions		Basic Load Ratings lbf N		Weight lb Kg	Limiting speed of Open Bearing (rpm)	
							r	r ₂	D ₂	f	a	b	Dynamic Cr	Static Cor		oil	grease
W6302	.5906	.0003	1.6535	.0005	.748	.0047	.039	.020	1.823	.044	.081	.053	2,570	1,220	.280	21,000	17,000
	15	.008	42	.011	19.00	.120	1.0	.5	46.3	1.12	2.06	1.35	11,400	5,450	.127		
W6303	.6693	.0003	1.8504	.0005	.875	.0047	.039	.020	2.075	.044	.097	.053	3,060	1,470	.320	19,000	16,000
	17	.008	47	.011	22.22	.120	1.0	.5	52.7	1.12	2.46	1.35	13,600	6,650	.145		
W6304	.7874	.0004	1.0472	.0005	.8750	.0047	.043	.020	2.280	.044	.097	.053	3,600	1,770	.480	17,000	14,000
	20	.010	52	.013	22.22	.120	1.1	.5	57.9	1.12	2.46	1.35	15,900	7,900	.218		
W6305	.9843	.0004	2.4409	.0005	1.000	.0047	.043	.020	2.665	.067	.129	.075	4,750	2,460	.780	14,000	12,000
	25	.010	62	.013	25.40	.120	1.1	.5	67.7	1.7	3.28	1.9	21,200	11,200	.354		
W6306	1.1811	.0004	2.8346	.0005	1.188	.0047	.043	.020	3.094	.067	.129	.075	6,000	3,375	1.130	12,000	10,000
	30	.010	72	.013	30.18	.120	1.1	.5	78.6	1.7	3.28	1.9	26,700	15,000	.513		
W6307	1.3780	.0005	3.1496	.0005	1.375	.0047	.059	.020	3.409	.067	.129	.075	7,537	4,320	1.640	10,000	8,800
	35	.012	80	.013	34.92	.120	1.5	.5	86.6	1.7	3.28	1.9	33,500	19,200	.744		
W6308	1.5748	.0005	3.5433	.0006	1.438	.0047	.059	.020	3.799	.097	.129	.106	9,112	5,400	2.060	9,200	7,800
	40	.012	90	.015	36.53	.120	1.5	.5	96.5	2.46	3.28	2.7	40,500	24,000	.937		
W6309	1.7717	.0005	3.9370	.0006	1.562	.0047	.059	.020	4.193	.097	.129	.106	11,925	7,200	3.000	8,200	7,000
	45	.012	100	.015	39.67	.120	1.5	.5	106.5	2.46	3.28	2.7	53,000	32,000	1.361		
W6310	1.9685	.0005	4.3307	.0006	1.750	.0047	.079	.020	4.591	.097	.129	.106	13,950	8,600	3.750	7,500	6,400
	50	.012	110	.015	44.45	.120	2.0	.5	116.6	2.46	3.28	2.7	62,000	38,500	1.701		
W6311	2.1654	.0006	4.7244	.0006	1.938	.0059	.079	.020	5.106	.111	.160	.122	16,100	10,125	5.120	6,800	5,800
	55	.015	120	.015	49.23	.150	2.0	.5	129.7	2.82	4.06	3.1	71,500	45,000	2.322		
W6312	2.3622	.0006	5.1181	.0007	2.125	.0059	.079	.020	5.500	.111	.160	.122	18,450	11,700	6.500	6,300	5,400
	60	.015	130	.018	53.98	.150	2.1	.5	139.7	2.82	4.06	3.1	82,000	52,000	2.948		
W6313	2.5591	.0006	5.5118	.0007	2.312	.0059	.079	.020	5.894	.111	.193	.122	20,800	13,500	8.170	5,800	4,900
	65	.015	140	.018	58.72	.150	2.1	.5	149.7	2.82	4.9	3.1	92,500	60,000	3.706		
W6314	2.7559	.0006	5.9055	.0007	2.500	.0059	.079	.020	6.287	.111	.193	.122	23,400	15,300	10.500	5,400	4,600
	70	.015	150	.018	63.50	.150	2.1	.5	159.7	2.82	4.9	3.1	104,000	68,000	4.763		
W6315	2.9528	.0006	6.2992	.0010	2.688	.0059	.079	.020	6.681	.111	.193	.122	25,425	17,325	12.800	5,000	4,300
	75	.015	160	.025	68.28	.150	2.1	.5	169.7	2.82	4.9	3.1	113,000	77,000	5.806		

*Maximum fillet which corner radius of bearing will clear.

8000, 87000 & 88000 SERIES

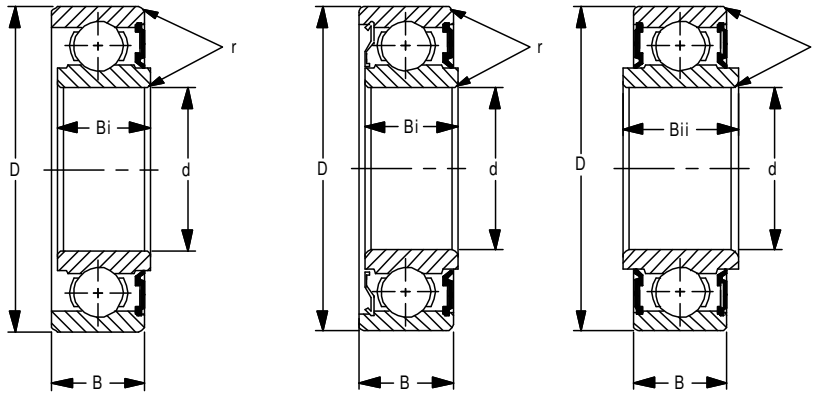

For applications where dirt exclusion and lubrication retention are primary considerations. This series is designed with an extended inner race to meet the exact dimensions of the felt series. Varying the contact pressure of the lip seal allows these bearings to be used for extremely high speed as well as for normal applications. The 88000 series, identical to the 8000 and 87000 series, has the added advantage of a Buna N Seal on both sides of the bearing. Identical in dimension to the felt series, this sealed bearing prevents contamination from entering the raceway.

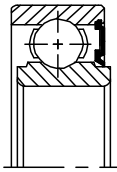

8000
SEAL

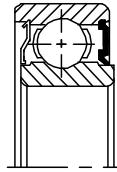

87000
SEAL AND SHIELD

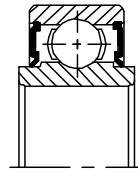

88000
DOUBLE SEALED

Units: Inches
Metric

Part Number	Bore d	OD D	Outer Ring Width B	Inner Ring Width		Overall Width	Fillet Radius		snap ring dimensions		snap ring groove dimensions		Basic Load Ratings lbs N		Weight lbs Kg		
				B _i	B _{ii}		r	r ₂	D ₂ Max	f Max	a Max	b Min	Dynamic C	Static Cor	8000	87000	88000
8035 87035 88035	.1969 5	.7480 19	.3150 8	.3860 9.804	.4970 12.624	.4063 10.319	.012 .3						525 2,335	199 885	.022 .010	.023 .010	.026 .012
8036 87036 88036	.2362 6	.7480 19	.3150 8	.3860 9.804	.4970 12.624	.4063 10.319	.012 .3	.008 .2	.878 22.3	.028 .7	.068 1.73	.031 .8	525 2,335	199 885	.024 .011	.025 .011	.027 .012
8006 87006 88006	.2362 6	.9449 24	.3150 8	.3860 9.804	.4970 12.624	.4063 10.319	.012 .3	.012 .3	1.102 28	.028 .7	.068 1.73	.031 .8	750 3,336	315 1,401	.046 .021	.048 .022	.055 .025
8037 87037 88037	.2756 7	.8661 22	.3150 8	.3860 9.804	.4970 12.624	.4063 10.319	.012 .3	.012 .3	1.024 26	.028 .7	.068 1.73	.031 .8	750 3,336	315 1,401	.037 .017	.039 .018	.043 .020
8007 87007 88007	.2756 7	.9449 24	.3150 8	.3860 9.804	.4970 12.624	.4063 10.319	.012 .3	.012 .3	1.102 28	.028 .7	.068 1.73	.031 .8	900 4,003	355 1,579	.045 .020	.047 .021	.051 .023
8038 87038 88038	.3150 8	.8661 22	.3150 8	.3860 9.804	.4970 12.624	.4063 10.319	.012 .3	.012 .3	1.024 26	.028 .7	.068 1.73	.031 .8	750 3,336	315 1,401	.036 .016	.038 .017	.040 .018
8008 87008 88008	.3150 8	.9449 24	.3150 8	.3860 9.804	.4970 12.624	.4063 10.319	.012 .3	.012 .3	1.102 28	.028 .7	.068 1.73	.031 .8	900 4,003	355 1,579	.043 .022	.044 .020	.048 .022
8039 87039 88039	.3543 9	1.0236 26	.3150 8	.3860 9.804	.4970 12.624	.4063 10.319	.025 .6	.012 .3	1.181 30	.028 .7	.068 1.73	.031 .8	1,030 4,581	440 1,957	.051 .023	.053 .024	.057 .026
8009 87009 88009	.3543 9	1.1811 30	.3543 9	.4800 12.192	.6457 16.401	.5000 12.700	.025 .6	.020 .5	1.437 36.5	.044 1.12	.081 2.06	.053 1.35	1,150 5,115	540 2,402	.078 .035	.095 .043	.105 .048
8500 87500 88500	.3937 10	1.1811 30	.3543 9	.4800 12.192	.6457 16.401	.5000 12.700	.025 .6	.020 .5	1.366 34.7	.044 1.12	.081 2.06	.053 1.35	1,150 5,115	540 2,402	.075 .034	.077 .035	.091 .041
8011 87011 88011	.4331 11	1.2598 32	.3937 10	.4800 12.192	.6063 15.400	.5000 12.700	.025 .6	.020 .5	1.445 36.7	.044 1.12	.081 2.06	.053 1.35	1,370 6,094	615 2,736	.099 .045	.101 .046	.104 .047
8501 87501 88501	.4724 12	1.2598 32	.3937 10	.4800 12.192	.6063 15.400	.5000 12.700	.025 .6	.020 .5	1.445 36.7	.044 1.12	.081 2.06	.053 1.35	1,370 6,094	615 2,736	.095 .043	.097 .044	.099 .045

*Maximum fillet which corner radius of bearing will clear.



8000, 87000 & 88000 SERIES (continued)

The basic 6300 series ball complement with two Buna N seals. Extended inner rings make this series perfectly interchangeable with the standard 8600, 87600 and 88600 felt series. By increasing contact pressure, the 6300 series can be used for rugged farm applications as well as for electric motors. Consult the Peer sales engineer for your specific requirements.

Units: Inches
Metric

Part Number	Bore d	OD D	Outer Ring Width B	Inner Ring Width		Overall Width	Fillet Radius		snap ring dimensions		snap ring groove dimensions		Basic Load Ratings lbs N		Weight lbs Kg 88000		
				B _I	B _{II}		r	r ₂	D ₂ Max	f Max	a Max	b Min	Dynamic C	Static Cor	8000	87000	88000
8013 87013 88013	.5118	1.2598	.3937	.4800	.6063	.5000	.025	.020	1.445	.044	.081	.053	1,370	615	.091	.093	.095
	13	32	10	12.624	15.400	12.700	.6	.50	36.7	1.12	2.06	1.35	6,094	2,736	.041	.042	.043
8014 87014 88014	.5512	1.3780	.4331	.4800	.5669	.5000	.025	.020	1.563	.044	.081	.053	1,740	805	.111	.115	.125
	14	35	11	12.624	14.399	12.700	.6	.50	39.7	1.12	2.06	1.35	7,740	3,581	.050	.052	.057
8502 87502 88502	.5906	1.3780	.4331	.4800	.5669	.5000	.025	.020	1.563	.044	.081	.053	1,740	805	.106	.108	.119
	15	35	11	12.624	14.399	12.700	.6	.50	39.7	1.12	2.06	1.35	7,740	3,581	.048	.049	.054
8016 87016 88016	.6299	1.3780	.4331	.4800	.5669	.5000	.025	.020	1.563	.044	.081	.053	1,740	805	.101	.105	.114
	16	35	11	12.624	14.399	12.700	.6	.50	39.7	1.12	2.06	1.35	7,740	3,581	.046	.048	.052
8602 87602 88602	.5906	1.6535	.5118	.5512	.6693	.5906	.040	.020	1.823	.044	.081	.053	2,570	1,220	.188	.193	.210
	15	42	13	14.000	17.000	15.000	1.0	.50	46.3	.112	2.06	1.35	11,451	5,427	.085	.088	.095
8503 87503 88503	.6693	1.5748	.4724	.5380	.6536	.5625	.025	.020	1.756	.044	.081	.053	2,160	1,030	.150	.154	.166
	17	40	12	13.665	16.601	14.288	.6	.50	44.6	1.12	2.06	1.35	9,608	4,581	.068	.070	.075
8603 87603 88603	.6693	1.8504	.5512	.5906	.7087	.6299	.040	.020	2.075	.044	.097	.053	3,050	1,470	.254	.257	.279
	17	47	14	15.000	18.000	16.000	1.0	.50	52.7	1.12	2.46	1.35	13,566	6,539	.115	.117	.127
8504 87504 88504	.7874	1.8504	.5512	.6000	.6988	.6250	.040	.020	2.075	.044	.097	.053	2,890	1,500	.232	.237	.259
	20	47	14	15.240	17.750	15.875	1.0	.50	52.7	1.12	2.46	1.35	12,855	6,672	.105	.108	.118
8604 87604 88604	.7874	2.0472	.5906	.7087	.9055	.7480	.040	.020	2.280	.044	.097	.053	3,600	1,770	.345	.352	.398
	20	52	15	18.000	23.000	19.000	1.0	.50	52.7	1.12	2.46	1.35	16,013	7,873	.157	.160	.181
8505 87505 88505	.9843	2.0472	.5906	.6000	.6594	.6250	.040	.020	2.280	.044	.097	.053	3,150	1,770	.287	.292	.304
	25	52	15	15.240	16.749	15.875	1.0	.50	57.9	1.12	2.46	1.35	14,011	7,873	.130	.133	.138
8605 87605 88605	.9843	2.4409	.6693	.8268	.9843	.8268	.040	.020	2.665	.067	.129	.075	4,750	2,460	.590	.600	.650
	25	62	17	21.000	25.000	21.000	1.0	.50	67.7	1.7	3.28	1.39	21,128	10,942	.268	.272	.295
8026 87026 88026	1.0236	2.0472	.5906	.6000	.6594	.6250	.040	.020	2.280	.044	.097	.053	3,150	1,770	.277	.282	.294
	26	52	15	15.240	16.749	15.875	1.0	.50	57.9	1.12	2.46	1.35	14,011	7,873	.126	.128	.133
8506 87506 88506	1.1811	2.4409	.6299	.7480	.9449	.7874	.040	.020	2.665	.067	.129	.075	4,400	2,540	.495	.506	.571
	30	62	16	19.000	24.000	20.000	1.0	.50	67.7	1.7	3.28	1.9	19,571	11,298	.225	.230	.259
8606 87606 88606	1.1811	2.8346	.7480	.9055	1.0630	.9055	.040	.020	3.094	.067	.129	.075	6,000	3,400	.860	.890	.970
	30	72	19	23.000	27.000	23.000	1.0	.50	78.5	1.7	3.28	1.9	26,688	15,123	.390	.404	.440
8507 87507 88070	1.3780	2.8346	.6993	.7874	.9843	.8268	.040	.020	3.094	.067	.129	.075	5,750	3,450	.695	.708	.765
	35	72	17	20.000	25.000	21.000	1.0	.50	78.6	1.7	3.28	1.9	25,576	15,346	.316	.321	.347
8607 87607 88607	1.3780	3.1496	.8268	.9843	1.1417	.9843	.060	.020	3.409	.067	.129	.075	7,500	4,300	1.10	1.12	1.20
	35	80	21	25.000	29.000	25.000	1.5	.50	86.6	1.7	3.28	1.9	33,360	19,126	.499	.508	.545
8508 87508 88508	1.5748	3.1496	.8268	.9449	1.0630	.9449	.040	.020	3.409	.067	.129	.075	6,550	4,000	1.03	1.07	1.18
	40	80	21	24.000	27.000	24.000	1.0	.50	86.6	1.7	3.28	1.9	29,134	17,792	.468	.486	.536
8608 87608 88608	1.5748	3.5433	.9055	1.0630	1.2205	1.0630	.060	.020	3.799	.097	.129	.106	9,150	5,400	1.53	1.56	1.65
	40	90	23	27.000	31.000	27.000	1.5	.50	96.5	2.46	3.28	2.7	40,699	24,019	.695	.708	.749
8509 87509 88509	1.7717	3.3465	.8268	.9449	1.0630	.9449	.040	.020	3.606	.067	.129	.075	7,350	4,600	1.19	1.20	1.22
	45	85	21	24.000	27.000	24.000	1.0	.50	91.6	1.70	3.28	1.90	32,693	20,461	.540	.545	.554
8609 87609 88609	1.7717	3.9370	.9843	1.1811	1.3780	1.1811	.060	.020	4.193	.097	.129	.106	11,900	7,200	1.96	2.01	2.19
	45	100	25	30.000	35.000	30.000	1.5	.50	106.5	2.46	3.28	2.7	52,931	32,026	.890	.913	.994
8510 87510 88510	1.9685	3.5433	.8661	1.0236	1.1811	1.0236	.040	.020	3.799	.097	.129	.106	7,900	5,200	1.27	1.30	1.40
	50	90	22	26.000	30.000	26.000	1.0	.50	96.5	2.46	3.28	2.7	35,139	23,130	.577	.590	.636
8511 87511 88511	2.1654	3.9370	.9055	1.0630	1.2205	1.0630	.060	.020	4.193	.097	.129	.106	9,750	6,550	1.60	1.64	1.78
	55	100	23	27.000	31.000	27.000	1.5	.50	106.5	2.46	3.28	2.7	43,368	29,134	.726	.745	.808
8512 87512 88512	2.3622	4.3307	.9843	1.1417	1.2992	1.1417	.060	.020	4.591	.097	.129	.106	11,800	8,150	2.11	2.10	2.34
	60	110	25	29.000	33.000	29.000	1.5	.50	116.6	2.46	3.28	2.7	52,486	36,251	.958	.953	1.062
8513 87513 88513	2.5591	4.7244	1.0236	1.2205	1.4173	1.2205	.060	.020	5.106	.111	.160	.122	12,900	9,000	2.79	2.80	3.05
	65	120	26	31.000	36.000	31.000	1.5	.50	129.7	2.82	4.06	3.1	57,379	40,032	1.267	.013	1.385
8514 87514	2.7559	4.9213	1.1024	1.2992	1.4961	1.2992	.060	.020	5.303	.111	.160	.122	14,000	9,400	3.00	3.08	
	70	125	28	33.000	38.000	33.000	1.5	.50	134.7	2.82	4.06	3.1	62,272	44,035	1.362	1.398	

*Maximum fillet which corner radius of bearing will clear.

WC8000, WC87000 & WC88000 SERIES

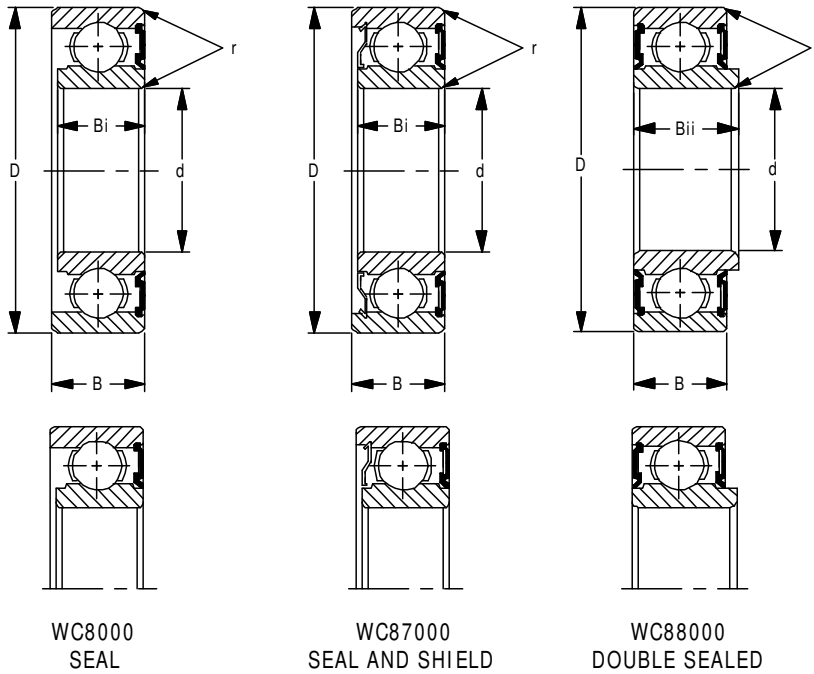

This series is made with contact Buna N Seals to meet the exact dimensions of the side cup WC felt series. The wider outer race offers greater contact with the housing, helping to reduce creeping and distortion of the housing bore. The Buna N Seal makes possible the advantage of variable lip pressure, used in higher speed applications. Specially designed for use in soft metal housings such as aluminum and magnesium. The wide outer ring series, with Buna N Seals on both sides, excludes dirt effectively under even the dirtiest conditions. In addition, the wide outer ring makes this series operable in a softer metal housing. Dirt exclusion is well controlled by the contact by the contact pressure of the Buna N Seal.

Units: Inches Metric

Part Number	Bore d	OD D	Outer Ring Width B	Inner Ring Width		Fillet radius r (min)	Basic Load Ratings lbf N		Weight lbs WC8000	Weight lbs Kg WC87000	Weight lbs WC88000
				Bi	Bii		Dynamic Cr	Static Cor			
WC8006 WC87006 WC88006	.2362 6	.9499 24	.4063 10.319	.3860 9.804	.4970 12.624	.012 .3	750 3,336	315 1,401	.060 .027	.060 .027	.060 .027
WC8007 WC87007 WC88007	.2756 7	.9449 24	.4063 10.319	.3860 9.804	.4970 12.624	.012 .3	900 4,003	355 1,579	.051 .023	.051 .023	.051 .023
WC8008 WC87008 WC88008	.3150 8	.9449 24	.4063 10.319	.3860 9.804	.4970 12.624	.012 .3	900 4,003	355 1,579	.050 .023	.050 .023	.050 .023
WC8009 WC87009 WC88009	.3543 9	1.1811 30	.5000 12.700	.4800 12.192	.6457 16.401	.025 .6	1150 5,115	540 2,402	.105 .048	.105 .048	.110 .050
WC8011 WC87011 WC88011	.4331 11	1.2598 32	.5000 12.700	.4800 12.192	.6063 15.400	.025 .6	1370 6,094	615 1,401	.110 .050	.110 .050	.100 .045
WC8013 WC87013 WC88013	.5118 13	1.2598 32	.5000 12.700	.4800 12.192	.6063 15.400	.025 .6	1370 6,094	615 1,401	.100 .045	.100 .045	.100 .045
WC8014 WC87014 WC88014	.5512 14	1.3780 35	.5000 12.700	.4800 12.192	.5669 14.399	.025 .6	1740 7,740	805 3,581	.110 .050	.110 .050	.125 .057
WC8016 WC87016 WC88016	.6299 16	1.3780 35	.5000 12.700	.4800 12.192	.5669 14.399	.025 .6	1740 7,740	805 3,581	.114 .052	.114 .052	.120 .054
WC8026 WC87026 WC88026	1.0236 26	2.0472 52	.6250 15.875	.6000 15.240	.6594 16.749	.040 1.0	3150 14,011	1770 7,873	.289 .131	.289 .131	.289 .131
WC8035 WC87035 WC88035	.1969 5	.7480 19	.4063 10.319	.3860 9.804	.4970 12.624	.012 .3	525 2,335	199 885	.026 .012	.026 .012	.030 .014
WC8036 WC87036 WC88036	.2362 6	.7480 19	.4063 10.319	.3860 9.804	.4970 12.624	.012 .3	525 2,335	199 885	.027 .013	.027 .013	.030 .014
WC8037 WC87037 WC88037	.2756 7	.8661 22	.4063 10.319	.3860 9.804	.4970 12.624	.012 .3	750 3,336	315 1,401	.043 .020	.043 .020	.043 .028
WC8038 WC87038 WC88038	.3150 8	.8661 22	.4063 10.319	.3860 9.804	.4970 12.624	.012 .3	750 3,336	315 1,401	.040 .018	.040 .018	.040 .018
WC8039 WC87039 WC88039	.3543 9	1.0236 26	.4063 10.319	.3860 9.804	.4970 12.624	.025 .6	1030 4,581	440 1,959	.06 .027	.06 .027	.06 .027
WC8500 WC87500 WC88500	.3937 10	1.1811 30	.5000 12.700	.4800 12.192	.6457 16.401	.025 .6	1150 5,150	540 2,402	.09 .041	.09 .041	.09 .041

*Maximum fillet which corner radius of bearing will clear.



WC8000, WC87000 & WC88000 SERIES (continued)

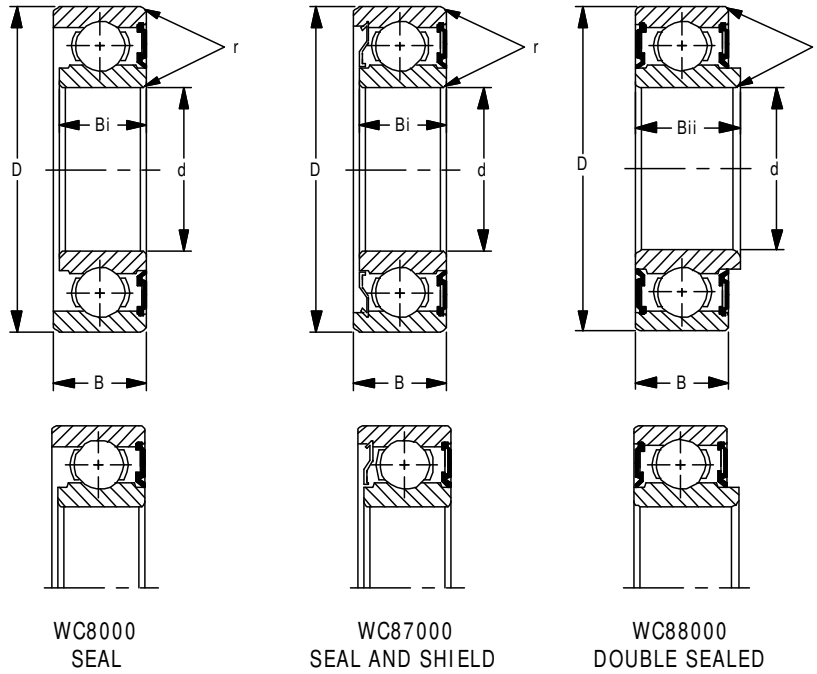

Units: Inches Metric

Part Number	Bore d	OD D	Outer Ring Width B	Inner Ring Width		Fillet radius r (min)	Basic Load Ratings lbf N		Weight lbs WC8000	Weight lbs kg WC87000	Weight lbs kg WC88000
				Bi	Bii		Dynamic Cr	Static Cor			
WC8501 WC87501 WC88501	.4724 12	1.2598 32	.5000 12.700	.4800 12.192	.6063 15.400	.025 .6	1370 6,094	615 2,736	.100 .045	.100 .045	.100 .045
WC8502 WC87502 WC88502	.5906 15	1.3780 35	.5000 12.700	.4800 12.192	.5669 14.399	.025 .6	1740 7,740	805 3,581	.120 .054	.120 .054	.119 .054
WC8503 WC87503 WC88503	.6693 17	1.5748 40	.5625 14.288	.5380 13.665	.6536 16.601	.025 .6	2160 9,608	1030 4,851	.170 .077	.170 .077	.170 .077
WC8504 WC87504 WC88504	.7874 20	1.8504 47	.6250 15.875	.6000 15.240	.6988 17.750	.040 1.0	2890 12,855	1500 6,672	.260 .118	.260 .118	.259 .117
WC8505 WC87505 WC88505	.9843 25	2.0472 52	.6250 15.875	.6000 15.240	.6594 16.749	.040 1.0	3150 14,011	1770 7,873	.304 .138	.304 .138	.304 .138
WC8506 WC87506 WC88506	1.1811 30	2.4409 62	.7874 20.000	.7480 19.000	.9449 24.000	.040 1.0	4400 19,571	2540 11,298	.543 .246	.543 .246	.523 .237
WC8507 WC87507 WC88507	1.3780 35	2.8346 72	.8268 21.000	.7874 20.000	.9843 25.000	.040 1.0	5750 25,576	3450 15,346	.765 .347	.765 .347	.749 .340
WC8508 WC87508 WC88508	1.5748 40	3.1496 80	.9449 24.000	.9449 24.000	1.0630 27.000	.040 1.0	6550 29,134	4000 17,792	1.18 .535	1.18 .535	1.180 .535
WC8509 WC87509 WC88509	1.7717 45	3.3465 85	.9449 24.000	.9449 24.000	1.0630 27.000	.040 1.0	7350 32,693	4600 20,461			1.220 .553
WC8510 WC87510 WC88510	1.9685 50	3.5433 90	1.0236 26.000	1.0236 26.000	1.1811 30.000	.040 1.0	7900 35,139	5200 23,130	1.260 .572	1.260 .572	1.300 .590
WC8511 WC87511 WC88511	2.1654 55	3.9370 100	1.0630 27.000	1.0630 27.000	1.2205 31.000	.060 1.5	9750 43,358	6550 29,134	1.630 .739	1.630 .739	1.660 .753

*Maximum fillet which corner radius of bearing will clear.

7200 ANGULAR CONTACT SERIES

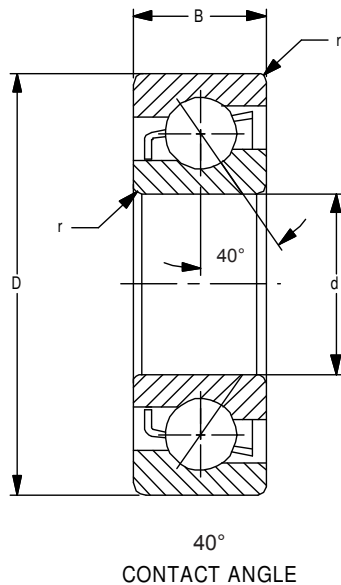

The 7200 series is a light duty series used in applications that call for thrust or combination thrust and radial loads. Standard production is made with 40° contact angle. This series is available with various contact angles. Consult your Peer sales engineer to discuss your exact requirements. Retainers can be made of various materials: bronze, brass or non-metallic. Duplex pairing is available upon request.

A=30° Contact Angle
 B=40° Contact Angle
 C=15° Contact Angle

Units: Inches
 Metric

Part Number	Bore d	Tolerance +.0000 to minus	OD D	Tolerance +.0000 to minus	Width B	Tolerance +.0000 to minus	* fillet radii r	Basic Load Ratings lbf N		Weight lb Kg
								Dynamic Cr	Static Cor	
7200	.3937	.0003	1.1811	.0005	.3543	.0047	.024	1,220	615	.064
	10	.008	30	.011	9	.120	.6	5,426	2,735	.029
7201	.4724	.0003	1.2598	.0005	.3937	.0047	.024	1,676	843	.077
	12	.008	32	.011	10	.120	.6	7,450	3,750	.034
7202	.5906	.0003	1.3780	.0005	.4331	.0047	.024	2,040	1,060	.110
	15	.008	35	.011	11	.120	.6	9,073	4,714	.050
7203	.6693	.0003	1.5748	.0005	.4724	.0047	.024	2,690	1,690	.140
	17	.008	40	.011	12	.120	.6	11,965	6,627	.064
7204	.7874	.0004	1.8504	.0005	.5512	.0047	.039	3,250	1,890	.250
	20	.010	47	.011	14	.120	1.0	14,456	8,406	.113
7205	.9843	.0004	2.0472	.0005	.5906	.0047	.039	3,650	2,320	.290
	25	.010	52	.011	15	.120	1.0	16,235	10,319	.132
7206	1.1811	.0004	2.4409	.0005	.6299	.0047	.039	5,050	3,350	.425
	30	.010	62	.011	16	.120	1.0	22,462	14,900	.193
7207	1.3780	.0005	2.8346	.0005	.6693	.0047	.039	6,700	4,500	.660
	35	.012	72	.011	17	.120	1.0	29,800	20,016	.299
7208	1.5748	.0005	3.1496	.0005	.7087	.0047	.039	7,950	5,650	.783
	40	.012	80	.011	18	.120	1.0	35,361	25,130	.355
7209	1.7717	.0005	3.3465	.0006	.7480	.0047	.039	8,900	6,450	.940
	45	.012	85	.015	19	.120	1.0	39,587	28,689	.426
7210	1.9685	.0005	3.5433	.0006	.7874	.0047	.039	9,300	7,050	1.000
	50	.012	90	.015	20	.120	1.0	41,366	31,358	.454
7211	2.1654	.0006	3.9370	.0006	.8268	.0059	.059	11,500	8,900	1.340
	55	.015	100	.015	21	.150	1.5	51,152	39,587	.608
7212	2.3622	.0006	4.3307	.0006	.8661	.0059	.059	13,900	11,000	1.79
	60	.015	110	.015	22	.150	1.5	61,827	48,928	.815
7213	2.5591	.0006	4.7244	.0006	.9055	.00659	.059	15,800	13,000	2.220
	65	.015	120	.015	23	.150	1.5	70,278	57,824	1.007
7214	2.7559	.0006	4.9213	.0007	.9449	.0059	.059	17,200	14,300	2.410
	70	.015	125	.018	24	.150	1.5	76,505	63,606	1.093

*Maximum fillet which corner radius of bearing will clear.



7200 ANGULAR CONTACT SERIES (continued)

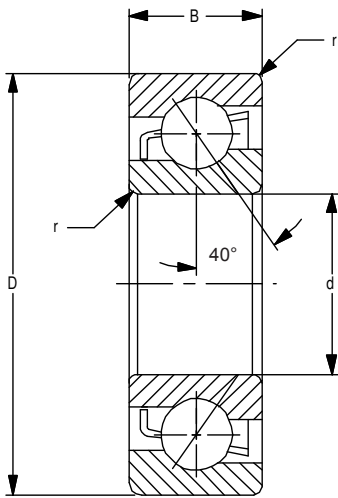

The 7200 series is a light duty series used in applications that call for thrust or combination thrust and radial loads. Standard production is made with 40° contact angle. This series is available with various contact angles. Consult your Peer sales engineer to discuss your exact requirements. Retainers can be made of various materials: bronze, brass or non-metallic. Duplex pairing is available upon request.

A=30° Contact Angle
B=40° Contact Angle
C=15° Contact Angle

40°
CONTACT ANGLE

Units: Inches
Metric

Part Number	Bore d	Tolerance +.0000 to minus	OD D	Tolerance +.0000 to minus	Width B	Tolerance +.0000 to minus	* fillet radii r	Basic Load Ratings lb N		Weight lb Kg
								Dynamic Cr	Static Cor	
7215	2.9528	.0006	4.1181	.0007	.9843	.0059	.059	17,800	15,400	2.590
	.75	.015	130	.018	25	.150	1.5	79,174	68,499	1.175
7216	3.1496	.0006	5.5118	.0007	1.0236	.0059	.079	20,000	17,100	3.130
	.80	.015	140	.018	26	.150	2.0	88,960	76,060	1.420
7217	3.3465	.0008	5.9055	.0007	1.1024	.0079	.079	22,400	19,900	3.940
	.85	.020	150	.018	28	.200	2.0	99,635	88,515	1.787
7218	3.5433	.0008	6.2992	.0010	1.1811	.0079	.079	26,500	23,200	5.000
	.90	.020	160	.025	30	.200	2.0	117,872	103,193	2.268
7219	3.7402	.0008	6.6929	.0010	1.2598	.0079	.079	30,000	26,500	5.900
	.95	.020	170	.025	32	.200	2.0	133,440	117,872	2.676
7220	3.9370	.0008	7.0866	.0010	1.3386	.0079	.079	32,500	28,200	7.200
	1.00	.020	180	.025	34	.200	2.0	144,560	125,433	3.266
7221	4.1339	.0008	7.4803	.0012	1.4173	.0079	.079	35,000	32,000	8.470
	1.05	.020	190	.030	36	.200	2.0	155,680	142,336	3.842
7222	4.3307	.0008	7.8740	.0012	1.4961	.0079	.079	38,000	35,500	1.200
	1.10	.020	200	.030	38	.200	2.0	169,024	157,904	4.627
7224	4.7244	.0008	7.4646	.0012	1.5748	.0079	.079	41,000	40,000	13.8
	1.20	.020	215	.030	40	.200	2.0	182,368	177,920	6.26
7226	5.1181	.0010	9.0551	.0012	1.5748	.0098	.098	44,000	44,500	15.65
	1.30	.025	230	.030	40	.250	2.5	195,712	197,936	7.10
7228	5.5118	.0010	9.8425	.0012	1.6535	.0098	.098	45,500	48,500	19.71
	1.40	.025	250	.030	42	.250	2.5	202,384	215,728	8.94
7230	5.9055	.0010	1.6299	.0014	1.7717	.0098	.098	52,000	58,000	24.69
	1.50	.025	270	.035	45	.250	2.5	231,296	257,984	11.2
7232	6.2992	.0010	11.4173	.0014	1.8898	.0098	.098	59,175	69,000	31.500
	1.60	.025	290	.035	48	.250	2.5	263,000	306,912	14.288
7234	6.6929	.0010	12.2047	.0014	2.0472	.0098	.118	66,375	81,000	38.600
	1.70	.025	310	.035	52	.250	3.0	295,000	360,000	17.509
7236	7.0866	.0012	12.5984	.0016	2.0472	.0098	.118	68,625	86,625	4.300
	1.80	.030	320	.040	52	.250	3.0	305,000	385,000	18.280
7238	7.4803	.0012	13.3858	.0016	2.1654	.0118	.118	70,875	92,250	5.700
	1.90	.030	340	.040	55	.300	3.0	315,000	410,000	22.998

*Maximum fillet which corner radius of bearing will clear.

7300 ANGULAR CONTACT SERIES

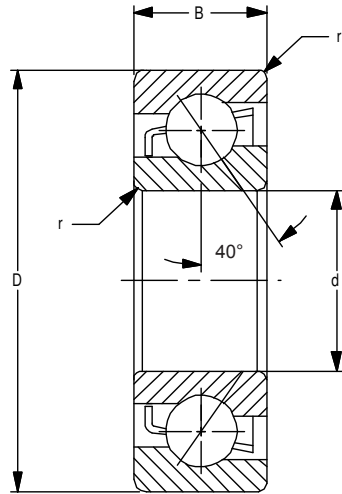

40°
CONTACT ANGLE

The 7300 series is a light duty series used in applications that call for thrust or combination thrust and radial loads. Standard production is made with 40° contact angle. This series is available with various contact angles. Consult your Peer sales engineer to discuss your exact requirements. Retainers can be made of various materials: bronze, brass or non-metallic. Duplex pairing is available upon request.

A=30° Contact Angle
B=40° Contact Angle
C=15° Contact Angle

Units: Inches
Metric

Part Number	Bore d	Tolerance +.0000 to minus	OD D	Tolerance +.0000 to minus	Width B	Tolerance +.0000 to minus	* fillet radius r	Basic Load Ratings lbf N		Weight lb Kg	Limiting speed of Open Bearing (rpm)	
								Dynamic Cr	Static Cor		oil	grease
7300	.3937	.0003	1.3780	.0005	.4331	.0047	.039	2,280	1,100	.120	24,000	18,000
	10	.008	35	.011	11	.120	1.0	10,141	4,892	.054		
7301	.4724	.0003	1.4567	.0005	.4724	.0047	.039	2,510	1,180	.136	21,000	15,000
	12	.008	37	.011	12	.120	1.0	11,164	5,248	.062		
7302	.5906	.0003	1.6535	.0005	.5118	.0047	.039	3,000	1,620	.189	18,000	14,000
	15	.008	42	.011	13	.120	1.0	13,344	7,205	.086		
7303	.6693	.0003	1.8504	.0005	.5512	.0047	.039	3,600	1,940	.260	16,000	12,000
	17	.008	47	.011	14	.120	1.0	16,000	8,629	.118		
7304	.7874	.0004	2.0472	.0005	.5906	.0047	.039	4,200	2,340	.340	15,000	10,500
	20	.010	52	.011	15	.120	1.0	18,683	10,4008	.154		
7305	.9843	.0004	2.4409	.0005	.6693	.0047	.039	5,950	3,550	.550	12,000	9,000
	25	.010	62	.011	17	.120	1.0	26,465	15,790	.249		
7306	1.1811	.0004	2.8346	.0005	.7480	.0047	.039	7,550	5,000	.800	10,500	8,000
	30	.010	72	.011	19	.120	1.0	33,582	22,240	.363		
7307	1.3780	.0005	3.1496	.0005	.8268	.0047	.059	9,000	5,900	1.030	9,000	6,900
	35	.012	80	.011	21	.120	1.5	40,036	26,243	.467		
7308	1.5748	.0005	3.5433	.0005	.9055	.0047	.059	11,000	7,400	1.410	8,000	6,000
	40	.012	90	.011	23	.120	1.5	48,928	32,915	.640		
7309	1.7717	.0005	3.9370	.0005	.9843	.0047	.059	14,300	9,800	1.880	7,300	5,500
	45	.012	100	.011	25	.120	1.5	63,606	43,590	.853		
7310	1.9685	.0005	4.3307	.0006	1.0630	.0047	.079	16,700	11,700	2.470	6,500	5,000
	50	.012	110	.015	27	.120	2.0	74,281	52,046	1.120		
7311	2.1654	.0006	4.7244	.0006	1.1417	.0059	.079	19,300	13,900	3.100	5,900	4,500
	55	.015	120	.015	29	.150	2.0	85,846	61,827	1.45		
7312	2.3622	.0006	5.1181	.0007	1.2205	.0059	.079	22,000	16,100	3.810	5,500	4,000
	60	.015	130	.018	31	.150	2.0	97,856	71,612	1.728		
7313	2.5591	.0006	5.5118	.0007	1.2992	.0059	.079	25,000	18,400	4.700	5,000	3,800
	65	.015	140	.018	33	.150	2.0	111,000	81,843	2.132		
7314	2.7559	.0006	5.9055	.0007	1.3780	.0059	.079	28,000	21,000	5.720	4,700	3,500
	70	.015	150	.018	35	.150	2.0	124,544	93,416	2.595		

*Maximum fillet which corner radius of bearing will clear.



7300 ANGULAR CONTACT SERIES (continued)

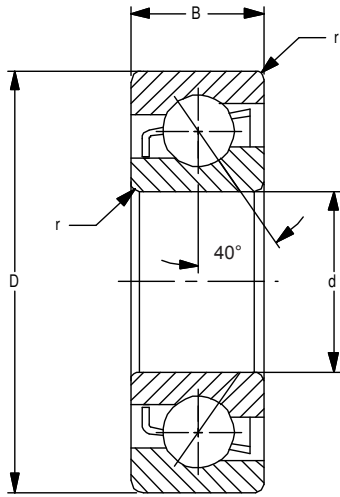

The 7300 series is a light duty series used in applications that call for thrust or combination thrust and radial loads. Standard production is made with 40° contact angle. This series is available with various contact angles. Consult your Peer sales engineer to discuss your exact requirements. Retainers can be made of various materials: bronze, brass or non-metallic. Duplex pairing is available upon request.

A=30° Contact Angle
B=40° Contact Angle
C=15° Contact Angle

40°
CONTACT ANGLE

Units: Inches
Metric

Part Number	Bore d	Tolerance +.0000 to minus	OD D	Tolerance +.0000 to minus	Width B	Tolerance +.0000 to minus	* fillet radius r	Basic Load Ratings		Weight lb Kg	Limiting speed of Open Bearing (rpm)	
								Dynamic Cr	Static Cor		oil	grease
7315	2.9528	.0006	6.2992	.0010	1.4567	.0059	.079	30,500	23,800	6.840	4,300	3,300
	75	.015	160	.025	37	.150	2.0	134,664	105,862	3.103		
7316	3.1496	.0006	6.6929	.0010	1.5354	.0059	.079	33,000	26,700	8.130	4,100	3,000
	80	.015	170	.025	39	.150	2.0	146,784	118,761	3.688		
7317	3.3465	.0008	7.0866	.0012	1.6142	.0079	.098	35,500	29,800	9.530	3,800	2,900
	85	.020	180	.030	41	.200	2.5	157,904	132,550	4.323		
7318	3.5433	.0008	7.4803	.0012	1.6929	.0079	.098	38,500	33,000	11.39	3,600	2,700
	90	.020	190	.030	43	.200	2.5	171,248	146,784	5.17		
7319	3.7402	.0008	7.8740	.0012	1.7717	.0079	.098	41,000	36,500	13.18	3,350	2,600
7320	95	.020	200	.030	45	.200	2.5	182,368	162,352	5.98		
	3.9370	.0008	8.4646	.0012	1.8504	.0079	.098	46,400	43,500	15.900	3,200	2,400
7321	100	.020	215	.030	47	.200	2.5	206,832	193,488	7.212		
	4.1339	.0008	8.8583	.0012	1.9291	.0079	.098	49,500	47,500	20.79	3,000	2,300
7322	105	.020	225	.030	49	.200	2.5	220,176	211,280	9.43		
	4.3307	.0008	9.4488	.0012	1.9685	.0079	.098	52,000	50,500	24.69	2,900	2,200
7324	110	.020	240	.030	50	.200	2.5	231,296	224,624	11.2		
	4.7244	.0008	1.2362	.0014	2.1654	.0079	.098	55,500	56,500	31.75	2,650	2,000
7326	120	.020	260	.035	55	.200	2.5	246,864	251,312	14.4		
	5.1181	.0010	11.0236	.0014	2.2835	.0098	.118	61,500	66,000	33.8	2,500	1,850
7328	130	.025	280	.035	58	.250	3.0	273,552	293,568	17.6		
	5.5118	.0010	11.8110	.0016	2.4409	.0098	.118	67,500	75,500	47.6	2,250	1,700
7330	140	.025	300	.040	62	.250	3.0	300,240	355,824	21.6		
	5.9055	.0010	1.5984	.0016	2.5591	.0098	.119	74,000	86,000	57.10	2,100	1,600
7332	150	.025	320	.040	65	.250	3.0	329,152	382,528	25.9		
	6.2992	.0010	13.3858	.0016	2.6772	.0098	.119	78,000	95,000	67.9	1,920	1,450
7334	160	.025	340	.040	68	.250	3.0	346,975	422,560	30.8		
	6.6929	.0010	14.1732	.0016	2.8/346	.0098	.120	87,500	109,000	77.00	1,850	1,350
7336	170	.025	360	.040	72	.250	3.0	389,200	484,832	35.000		
	7.0866	.0012	14.9606	.0016	2.9528	.0098	.120	92,000	120,000	93.9	1,700	1,300
7338	180	.030	380	.040	75	.250	3.0	409,216	533,8760	42.6		
	7.4803	.0012	15.7480	.0016	3.0709	.0098	.157	96,500	131,000	104.07	1,600	1,200
7340	190	.030	400	.040	78	.250	4.0	429,232	582,688	47.2		
	7.8740	.0012	16.5354	.0016	3.1496	.0098	.157	101,000	137,000	121.9	1,500	1,100
	200	.030	420	.040	80	.250	4.0	449,248	609,376	55.3		

*Maximum fillet which corner radius of bearing will clear.

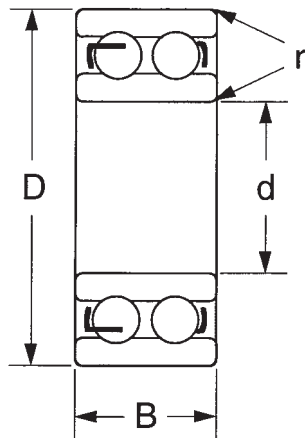

This series is used in instances of heavy radial loads, combined radial and thrust loads, and two directional loads. The non-filling slot allows high RPM. In addition, the angle of contact converges outside the bearing, offering increased resistance to overturning moments. Loading groove construction types are available upon request. Consult Peer sales engineer for availability.

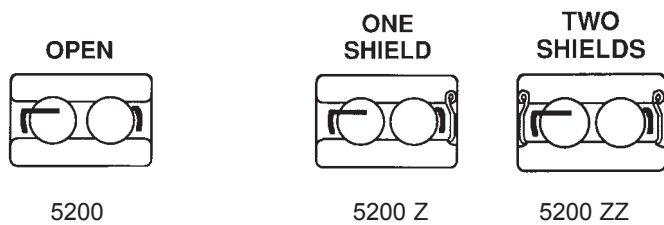

Units: Inches
Metric

Part Number	Bore d	Tolerance +.0000 to minus	OD D	Tolerance +.0000 to minus	Width B	Tolerance +.0000 to minus	* fillet radii r	Basic Load Ratings		Weight lb Kg	Limiting speed of Open Bearing (rpm)	
								Dynamic Cr	Static Cor		oil	grease
5200	.3937	.0003	1.1811	.0004	.5625	.0047	.024	1,608	877	.12	19,000	14,000
	10	.008	30	.009	14.287	.120	.6	7,150	3,900	.054		
5201	.4724	.0003	1.2598	.0005	.6250	.0047	.024	2,430	1,305	.125	17,000	13,000
	12	.008	32	.011	15.875	.120	.6	10,500	5,800	.057		
5202	.5906	.0003	1.3780	.0005	.6250	.0047	.024	2,632	1,586	.141	15,000	11,000
	15	.008	35	.011	15.875	.120	.6	11,700	7,050	.064		
5203	.6693	.0003	1.5748	.0005	.6875	.0047	.024	3,285	2,036	.211	13,000	9,900
	17	.008	40	.011	17.463	.120	.6	14,600	9,050	.096		
5204	.7874	.0004	1.8504	.0005	.8125	.0047	.039	4,410	2,790	.337	12,000	8,800
	20	.010	47	.011	20.638	.120	1.0	19,600	12,400	.153		
5205	.9843	.0004	2.0472	.0005	.8125	.0047	.039	4,792	3,307	.385	9,800	7,300
	25	.010	52	.011	20.638	.120	1.0	21,300	14,700	.175		
5206	1.1811	.0004	2.4409	.0005	.9375	.0047	.039	6,660	4,747	.629	8,400	6,300
	30	.010	62	.011	23.813	.120	1.0	29,600	21,100	.285		
5207	1.3780	.0005	2.8346	.0005	1.0625	.0047	.039	8,775	6,457	.959	7,400	5,500
	35	.012	72	.011	26.988	.120	1.0	39,000	28,700	.435		
5208	1.5748	.0005	3.1496	.0005	1.1875	.0047	.039	9,900	7,537	1.298	6,600	4,900
	40	.012	80	.011	30.163	.120	1.0	44,000	33,500	.589		
5209	1.7717	.0005	3.3465	.0006	1.1875	.0047	.039	11,137	8,550	1.408	5,900	4,400
	45	.012	85	.015	30.163	.120	1.0	49,500	38,000	.639		
5210	1.9685	.0005	3.5433	.0006	1.1875	.0047	.039	11,925	9,787	1.515	5,300	4,000
	50	.012	90	.015	30.163	.120	1.0	53,000	43,500	.687		
5211	2.1654	.0006	3.9370	.0006	1.3125	.0047	.059	12,600	11,025	2.169	4,900	3,600
	55	.015	100	.015	33.338	.120	1.5	56,000	49,000	.984		
5212	2.3622	.0006	4.3307	.0006	1.4375	.0047	.059	15,505	13,950	2.794	4,500	3,400
	60	.015	110	.015	36.513	.120	1.5	69,000	62,000	1.267		
5213	2.5591	.0006	4.7244	.0006	1.5000	.0047	.059	17,202	15,525	3.454	4,200	3,100
	65	.015	120	.015	38.100	.120	1.5	76,500	69,000	1.567		
5214	2.7559	.0006	4.9213	.0007	1.5625	.0047	.059	21,150	18,450	3.960	3,900	2,900
	70	.015	125	.018	39.688	.120	1.5	94,000	82,000	1.796		
5215	2.9528	.0006	5.1181	.0007	1.6250	.0047	.059	21,037	18,675	1.180	3,600	2,700
	75	.015	130	.018	41.275	.120	1.5	93,500	83,000	1.896		
5216	3.1496	.0006	5.5118	.0007	1.7500	.0047	.079	22,275	20,925	5.258	3,400	2,500
	80	.015	140	.018	44.45	.120	2.0	99,000	93,000	2.385		
5217	3.3465	.0006	5.9055	.0007	1.9375	.0059	.079	26,100	24,750	6.732	3,200	2,400
	85	.015	150	.018	49.213	.015	2.0	116,000	110,000	3.054		

*Maximum fillet which corner radius of bearing will clear.



W5200/W5300 SERIES

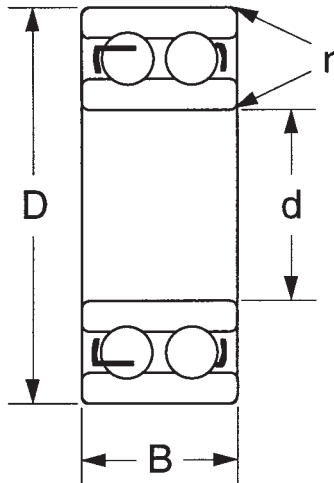

The same construction and ball compliment as the 5200 series. Made with a slightly larger width as a replacement for other manufacturers.

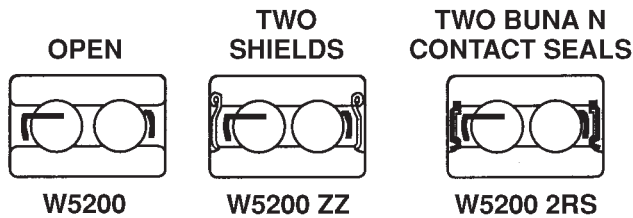

Units: Inches
Metric

Part Number	Bore d	Tolerance +.0000 to minus	OD D	Tolerance +.0000 to minus	Width B	Tolerance +.0000 to minus	* fillet radii r	Basic Load Ratings lbf N		Weight lb Kg	Limiting speed of Open Bearing (rpm)	
								Dynamic Cr	Static Cor		oil	grease
W5201	.4724	.0003	1.2598	.0005	.6875	.0050	.024	2,430	1,305	.162	16,150	12,350
	12	.008	32	.011	17.463		.6	10,500	5,800	.073		
W5202	.5906	.0003	1.378	.0005	.7500	.0050	.024	2,632	1,586	.171	14,250	10,450
	15	.008	35	.011	19.050		.6	11,700	7,050	.077		
W5203	.6693	.0003	1.5748	.0005	.8125	.0050	.024	3,285	2,036	.242	12,350	9,405
	17	.008	40	.011	20.638		.6	14,600	9,050	.110		
W5204	.7874	.0004	1.8504	.0005	.9375	.0050	.039	4,410	2,790	.401	11,400	8,400
	20	.010	47	.011	23.813		1.0	19,600	12,400	.182		
W5205	.9843	.0004	2.0472	.0005	.9375	.0050	.039	4,792	3,307	.441	9,310	7,000
	25	.010	52	.011	23.813		1.0	21,300	14,700	.200		
W5206	1.1811	.0004	2.4409	.0005	1.0625	.0050	.039	6,660	4,747	.711	8,400	6,000
	30	.010	62	.011	26.988		1.0	29,600	21,100	.323		
W5207	1.13780	.0005	2.8346	.0005	1.1890	.0050	.079	8,500	6,250	1.21	7,400	5,500
	35	.011	72	.011	30.2		2.0	37,812	27,803	.549		
W5304	.7874	.0004	2.0472	.0005	1.000	.0050	.079	4,650	2,850	.54	12,000	9,000
	20	.010	52	.011	25.4		2.0	20,685	12,678	.245		
W5305	.9843	.0004	2.4409	.0005	1.1250	.0050	.079	6,850	4,600	.89	10,000	8,000
	25	.010	62	.011	29.6		2.0	30,472	20,463	.404		
W5306	1.1811	.0004	2.8346	.0005	1.3125	.0050	.079	8,900	6,200	1.41	8,000	6,000
	30	.010	72	.011	33.3		2.0	39,591	27,580	.640		
W5307	1.3780	.0005	3.14796	.0005	1.500	.0050	.098	11,100	7,850	1.89	6,000	5,000
	35	.011	80	.011	38.1		2.5	49,378	34,920	.858		

*Maximum fillet which corner radius of bearing will clear.

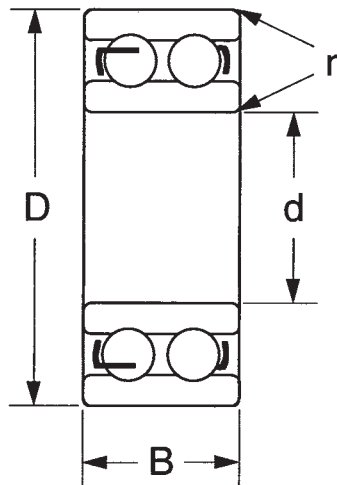

This series is manufactured with the same ID and OD as the 6300 bearings. By utilizing double row construction, the 5300 series is used with heavy radial, combined radial and thrust, or where there are two directional loads. The non-filling slot allows these bearings to be used at high RPM. They are available with shields and seals. Loading groove maximum construction types are manufactured upon request. Consult Peer sales engineer for availability.

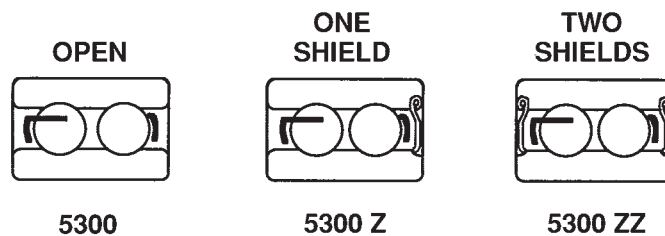

Units: Inches
Metric

Part Number	Bore d	Tolerance +.0000 to minus	OD D	Tolerance +.0000 to minus	Width B	Tolerance +.0000 to minus	* fillet radii r	Basic Load Ratings		Weight lb Kg	Limiting speed of Open Bearing (rpm)	
								Dynamic Cr	Static Cor		oil	grease
5302	.5906	.0003	1.6535	.0005	.7500	.0047	.039	3,960	2,295	.250	15,000	10,000
	15	.008	42	.011	19.050	.120	1.0	17,600	10,200	.113		
5303	.6693	.0003	1.8504	.0005	.8750	.0047	.039	4,725	2,835	.330	14,000	10,000
	17	.008	47	.011	22.225	.120	1.0	21,000	12,600	.150		
5304	.7874	.0004	2.0472	.0005	.8750	.0047	.039	5,530	3,370	.500	12,000	9,000
	20	.010	52	.011	22.225	.120	1.0	24,600	15,000	.227		
5305	.9843	.0004	2.4409	.0005	1.0000	.0047	.039	7,320	4,650	.750	10,000	8,000
	25	.010	62	.011	25.400	.120	1.0	32,500	20,700	.340		
5306	1.1811	.0004	2.8346	.0005	1.1875	.0047	.039	9,112	6,322	1.100	8,000	6,000
	30	.010	72	.011	30.163	.120	1.0	40,500	28,100	.499		
5307	1.3780	.0005	3.1496	.0005	1.3750	.0047	.059	11,475	8,100	1.700	6,000	5,000
	35	.012	80	.011	34.925	.120	1.5	51,000	36,000	.771		
5308	1.5748	.0005	3.5433	.0006	1.4375	.0047	.059	12,712	9,225	2.200	6,000	5,000
	40	.012	90	.015	36.513	.120	1.5	56,500	41,000	.998		
5309	1.7717	.0005	3.937	.0006	1.5625	.0047	.059	15,412	11,475	3.120	6,000	5,000
	45	.012	100	.015	39.688	.120	1.5	68,500	51,000	1.415		
5310	1.9685	.0005	4.3309	.0006	1.7500	.0047	.079	18,337	13,837	4.250	5,000	4,000
	50	.012	110	.015	44.450	.120	2.0	81,500	61,500	1.928		
5311	2.1654	.0006	4.7244	.0006	1.9375	.0059	.079	21,375	16,425	5.110	5,000	4,000
	55	.015	120	.015	49.213	.150	2.0	95,000	73,000	2.318		
5312	2.3622	.0006	4.1181	.0007	2.1250	.0059	.079	28,100	22,162	7.000	4,000	3,000
	60	.015	130	.018	53.975	.150	2.0	125,000	98,500	3.175		
5313	2.5591	.0006	5.5118	.0007	2.3125	.0059	.079	31,950	25,425	8.500	4,000	3,000
	65	.015	140	.018	58.738	.150	2.0	142,000	113,000	3.856		
5314	2.7559	.0006	5.9066	.0007	2.5000	.0059	.079	35,775	28,800	1.500	3,800	2,800
	70	.015	150	.018	63.500	.150	2.0	159,000	128,000	4.763		
5315	2.9528	.0006	6.2992	.0010	2.6875	.0059	.079	37,800	31,500	11.000	3,600	2,600
	75	.015	160	.025	68.263	.150	2.0	168,149	140,125	4.990		
5316	3.1496	.0006	6.6929	.0010	2.6875	.0059	.079	45,200	53,100	14.500	3,500	2,400
	80	.015	170	.025	68.263	.150	2.0	201,068	236,210	6.577		

*Maximum fillet which corner radius of bearing will clear.



MAST GUIDE SERIES

Specially designed bearings to handle mast movements of industrial trucks. This series will handle heavy radial and shock loads. Thick outer rings permit heavy OD loading. Specially designed seals allow the bearings to operate in adverse environments.

PEER Bearing No.	MRC Interchange	BCA Interchange	Hoover/NSK Interchange	
MG206FFA	206-SZZ-16	MG206FFA		
MG206SZZ-16				
MG207FFJ			MG207FFJ	
MG207FFJA			MG207FFJA	
MG207FFWA			MG207FFWA	
MG208FFA	208-SZZ-15	MG208FFA		
MG208SZZ-15			MG207FFH	
MG209MZZ-1		209-MZZ1	MG209-MZZ1	
MG305SZZ-3	305-SZZ-3	MG305DD	X421RS	
MG305SZZ-6	305-SZZ-6	MG305DDA		
MG305SZZ-7	305-SZZ-7			
MG306SZZ-5	306-SZZ-5	MG306DD	X555	
MG307SZZ-4	307-SZZ-4	MG307FFA		
MG307SZZ-9	307-SZZ-9	MG307FFK	X549RS	
MG307SZZ-10	307-SZZ-10	MG307FF(FFH)	X376RS	
MG307SZZ-14	307-SZZ-14			
MG307SZZ-18	307-SZZ-18	MG307FFP		
MG308SZZ-5	308-SZZ-5	MG308FFA		
MG309SZZ-1	309-SZZ-1		X469	
MG309SZZ-4	309-SZZ-4	MG309DDA	X501RS	
MG309SZZ-5	309-SZZ-5			
MG311SZZ-1	311-SZZ-1			

*Special sizes available upon request

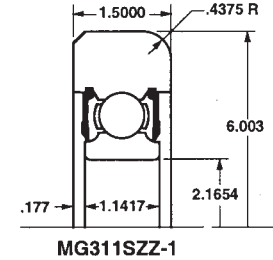
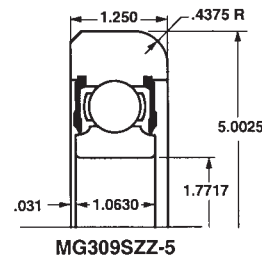
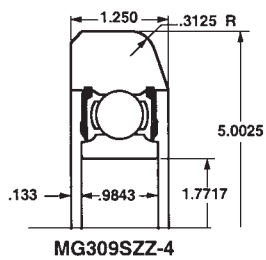
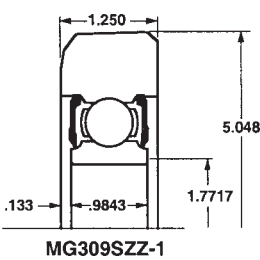
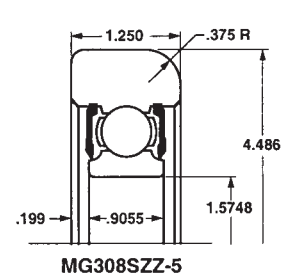
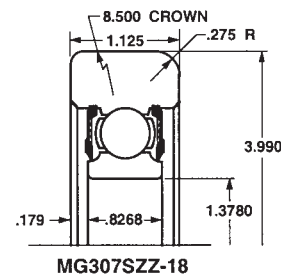
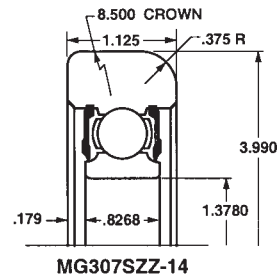
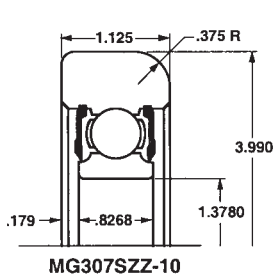
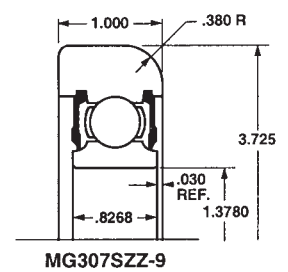
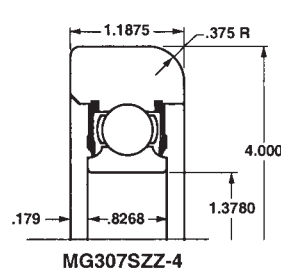
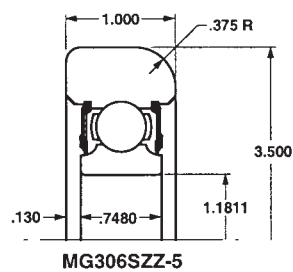
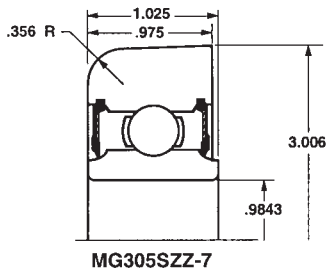
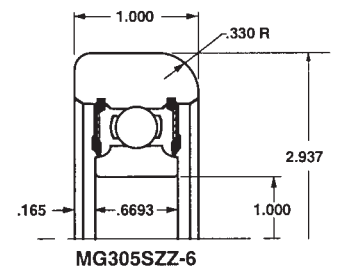
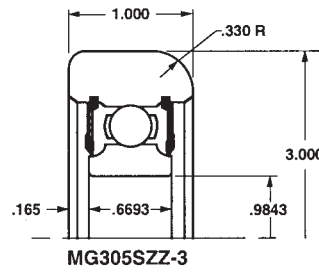
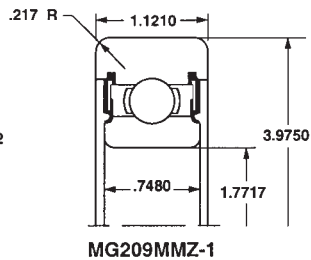
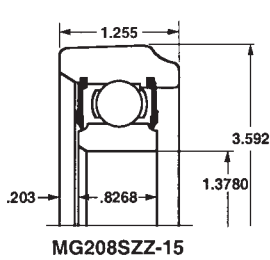
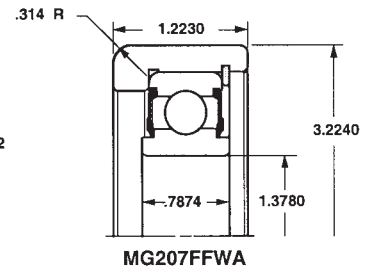
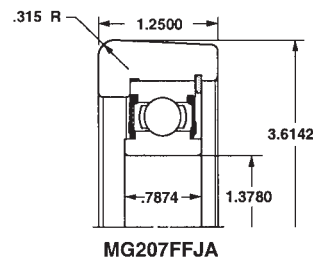
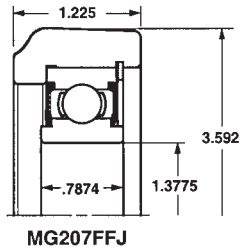
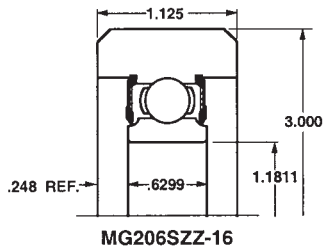



SPHERICAL PLAIN BEARINGS

GE SERIES

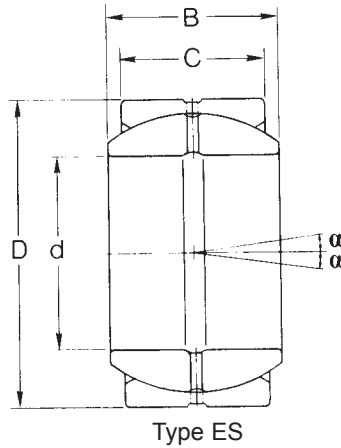
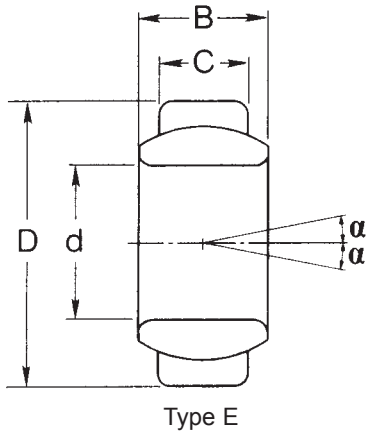

Spherical plain bearings are designed as open bearings or with seals to aid in dirt exclusion. Spherical plain bearings are used in severe misalignment conditions. Additional applications include oscillation, tilting and similar conditions where high rotation speeds are not required. Made in inch and metric dimensions.

INCH SERIES

Units: Inches
Metric

Designation Without Seals	Designation With Seals	d in. mm	D in. mm	B in. mm	B ₁ in. mm	Tilt Angle Degrees	Designation Without Seals	Designation With Seals	d in. mm	D in. mm	B in. mm	B ₁ in. mm	Tilt Angle Degrees
GEZ 008 ES	—	.5 12.700	.875 22.225	.437 11.10	.375 9.525	6	GEZ 208 ES	GEZ 208 ES-2RS	2.5 63.500	3.9375 100.013	2.187 55.55	1.875 47.625	6
GEZ 010 ES	—	.625 15.875	1.0625 26.988	.547 13.894	.469 11.913	6	GEZ 212 ES	GEZ 212 ES-2RS	2.75 69.850	4.375 111.125	2.406 61.112	2.062 52.375	6
GEZ 012 ES	—	.75 19.050	1.25 31.750	.656 16.662	.562 14.275	6	GEZ 300 ES	GEZ 300 ES-2RS	3 76.200	4.75 120.650	2.625 66.675	2.25 57.15	6
GEZ 014 ES	—	.875 22.225	1.4375 36.513	.756 19.431	.656 16.662	6	GEZ 304 ES	GEZ 304 ES-2RS	3.25 82.550	5.125 130.175	2.844 72.238	2.437 61.900	6
GEZ 100 ES	GEZ 100 ES02RS	1 25.400	1.625 41.275	.875 22.225	.75 19.05	6	GEZ 308 ES	GEZ 308 ES-2RS	3.5 88.900	.5 139.700	3.062 77.775	2.625 66.675	6
GEZ 104 ES	—	1.25 31.750	2 50.800	1.093 27.762	.937 23.80	6	GEZ 312 ES	GEZ 312 ES-2RS	3.75 95.250	5.875 149.225	3.281 83.337	2.812 71.425	6
GEZ 106 ES	—	1.375 34.925	2.1875 55.563	1.187 30.15	1.031 26.187	6	GEZ 400 ES	GEZ 400 ES-2RS	4 101.600	6.25 158.750	3.5 88.900	3 76.200	6
GEZ 108 ES	GEZ 108 ES-2RS	1.5 38.100	2.4375 61.913	1.312 33.325	1.125 28.575	6	GEZ 408 ES	GEZ 408 ES-2RS	4.5 114.300	7 177.800	3.937 100.000	3.375 85.725	6
GEZ 112 ES	GEZ 112 ES-2RS	1.75 44.450	2.8125 71.438	1.531 38.887	1.312 33.325	6	GEZ 500 ES	GEZ 500 ES-2RS	5 127.000	7.75 196.850	4.375 111.125	3.75 95.250	6
GEZ 200 ES	GEZ 200 ES-2RS	2 50.800	3.1875 80.963	1.751 44.45	1.5 38.10	6	GEZ 600 ES	GEZ 600 ES-2RS	6 152.400	8.75 222.250	4.75 120.650	4.125 104.775	5
GEZ 204 ES	GEZ 204 ES-2RS	2.25 57.150	3.5625 90.488	1.969 50.013	1.687 42.85	6							

METRIC SERIES

Designation Without Seals	Designation With Seals	d mm in.	D mm in.	B mm in.	B ₁ mm in.	Tilt Angle Degrees	Designation Without Seals	Designation With Seals	d mm in.	D mm in.	B mm in.	B ₁ mm in.	Tilt Angle Degrees
GE 4 E	—	4 .1575	12 .4724	5 .1969	3 .1181	16	GE 12 E	—	12 .4724	22 .8661	10 .3937	7 .4331	11
GE 5 E	—	5 .1969	14 9.3556	6 .2362	4 .1575	13	GE 15 ES	GE 15 ES-2RS	15 .5906	26 1.0236	12 .3048	9 .3543	8/5
GE 6 E	—	6 .2362	14 .03556	6 .2362	4 .1575	13	GE 17 ES	GE 17 ES-2RS	17 .6693	30 1.1811	14 .5512	10 .3937	10/7
GE 8 E	—	8 .3150	16 .6299	8 .3150	5 .1969	15	GE 20 ES	GE 20 ES-2RS	20 .7874	35 1.3780	16 .6299	12 .4724	9/6
GE 10 E	—	10 .3937	19 .7480	9 .3543	6 .2362	12	—	GEH 20 ES-2RS	20 1.6535	42 .9843	25 .9843	16 .6299	15

*Maximum fillet which corner radius of bearing will clear.

SPHERICAL PLAIN BEARINGS

GE SERIES (continued)

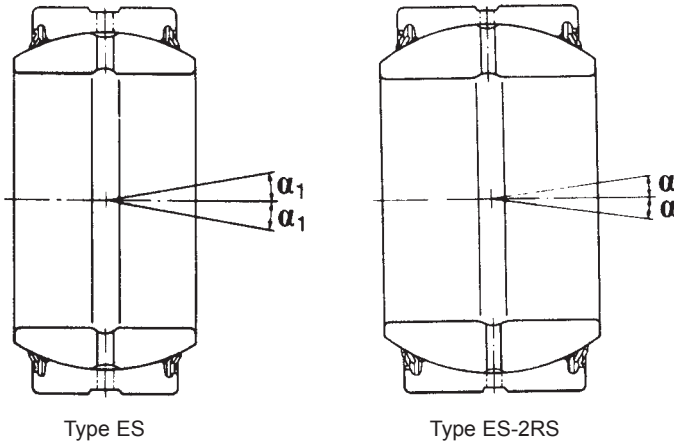

Spherical plain bearings are designed as open bearings or with seals to aid in dirt exclusion. Spherical plain bearings are used in severe misalignment conditions. Additional applications include oscillation, tilting and similar conditions where high rotation speeds are not required. Made in inch and metric dimensions.

Designation		d mm in.	D mm in.	B mm in.	B ₁ mm in.	Tilt Angle Degrees	Units:		d mm in.	D mm in.	B mm in.	B ₁ mm in.	Tilt Angle Degrees	
Without Seals	With Seals						Inches	Millimeters						
GE 25 ES	GE 25 ES-2RS	25 .9843	42 1.6535	20 .7874	16 .6299	7/4	GE 90 ES	GE 90 ES-2RS	90 3.5436	130 5.1182	60 2.3625	50 1.9688	5/3	
—	GEH 25 ES-2RS		47 1.8504	28 1.1024	18 .7087	14	GEH 90 ES	GEH 90 ES-2RS		150 5.9056	85 3.3464	55 2.1654	15/14	
GE 30 ES	GE 30 ES-2RS	30 1.1812	47 1.8504	22 8.6614	18 .7087	6/4	GE 100 ES	GE 100 ES-2RS	100 3.9373	150 5.9056	70 2.7562	55 2.1654	7/5	
—	GEH 30 ES-2RS		55 2.1653	32 1.2598	20 .7874	16	—	GEH 100 ES-2RS		160 6.2993	85 3.3464	55 2.1654	12	
GE 35 ES	GE 35 ES-2RS	35 1.3781	55 2.1653	25 .9843	20 .7874	6/4	GE 110 ES	GE 100 ES-2RS	110 4.3310	160 6.2993	70 2.7562	55 2.1654	6/4	
—	GEH 35 ES-2RS		62 2.4409	35 1.3781	22 .8661	15	—	GEH 100 ES-2RS		180 7.0867	100 3.9373	70 2.7562	11	
GE 40 ES	GE 40 ES-2RS	40 1.5750	62 2.4409	28 1.1024	22 .8661	7/4	GE 120 ES	GE 120 ES-2RS	120 4.7247	180 7.0867	85 3.3464	70 2.7562	6/4	
—	GEH 40 ES-2RS		68 2.6772	40 1.5750	25 .9843	14	GEH 120 ES	—		210 8.7678	115 4.5276	70 2.7562	16	
GE 45 ES	GE 45 ES-2RS	45 1.7719	68 2.6772	32 1.2398	25 .9843	7/4	GE 140 ES	GE 140 ES-2RS	140 5.5121	210 8.7678	90 3.5436	70 2.7562	7/5	
—	GEH 45 ES-2RS		75 2.9528	43 1.6929	28 1.1024	13	GE 160 ES	GE 160 ES-2RS	160 6.2935	230 9.0552	105 4.1339	80 3.1499	8/6	
GE 50 ES	GE 50 ES-2RS	50 1.9688	75 2.9528	35 1.3781	28 1.1024	6/4	GE 180 ES	GE 180 ES-2RS	180 7.0869	260 10.2363	105 4.1339	80 3.1499	6/4	
—	GEH 50 ES-2RS		90 3.5433	56 2.2047	36 1.4173	16	GE 200 ES	—		290 7.8743	130 11.4174	100 5.1182	7	
GE 60 ES	GE 60 ES-2RS	60 2.3625	90 3.5433	44 1.7323	36 1.4173	6/3	GE 220 ES	—		220 8.6617	320 12.5985	135 5.3151	100 3.9373	8
—	GEH 60 ES-2RS		105 4.1339	63 2.4803	40 1.5750	15	GE 240 ES	—		240 9.4491	340 13.3859	140 5.5121	100 3.9373	8
GE 70 ES	GE 70 ES-2RS	70 2.7562	105 4.1339	49 1.9291	40 1.5750	6/4	GE 260 ES	—		260 10.2365	370 14.5670	150 6.1025	110 4.3310	7
GEH 70 ES	GEH 70 ES-2RS		120 4.7245	70 2.7562	45 1.7719	16/14	GE 280 ES	—		280 11.0239	400 15.7481	155 6.2994	120 4.7247	6
GE 80 ES	GE 80 ES-2RS	80 3.1499	120 4.7245	55 2.1654	45 1.7719	6/4	GE 300 ES	—		300 11.8113	430 16.9292	165 6.6931	120 4.7247	7
—	GEH 80 ES-2RS		130 5.1182	75 2.9528	50 1.9688	13								

*Maximum fillet which corner radius of bearing will clear.

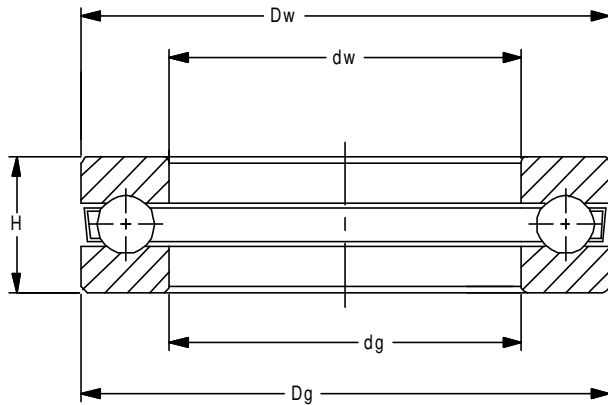

Thrust ball bearings single direction. Thrust ball bearings are available in both the single and double direction designs. Either one can take high axial load but no radial load. Besides the conventional design with flat supporting surfaces, the standard includes thrust ball bearings made with spherical housing washers and seating rings.

Part Number	Dimensions (Metric)					Approx. Wgt. (lbs.)	Interchange			
	dw	dg	Dw	Dg	H		FAG SKF (Eur.)	RHP SNR	RIV	
51100	10	11	24	24	9	0.05	51100	51100	ELP	10
51101	12	13	26	26	9	0.05	51101	51101	ELP	12
51102	15	16	28	28	9	0.06	51102	51102	ELP	15
51103	17	18	30	30	9	0.07	51103	51103	ELP	17
51104	20	21	35	35	10	0.09	51104	51104	ELP	20
51105	25	26	42	42	11	0.13	51105	51105	ELP	25
51106	30	32	47	47	11	0.14	51106	51106	ELP	30
51107 X	35	37	52	52	12	0.20	51107 X	51107 X	ELPn	35
51107	35	37	53	53	12	0.22	51107	51107	ELP	35
51108	40	42	60	60	13	0.26	51108	51108	ELP	40
51109	45	47	65	65	14	0.31	51109	51109	ELP	45
51110	50	52	70	70	14	0.34	51110	51110	ELP	50
51111	55	57	78	78	16	0.48	51111	51111	ELP	55
51112	60	62	85	85	17	0.62	51112	51112	ELP	60
51113	65	67	90	90	18	0.71	51113	51113	ELP	65
51114	70	72	95	95	18	0.77	51114	51114	ELP	70
51115	75	77	100	100	19	0.86	51115	51115	ELP	75
51116	80	82	105	105	19	0.90	51116	-	ELP	80
51117	85	87	110	110	19	0.93	51117	-	ELP	85
51118	90	92	120	120	22	1.41	51118	-	ELP	90
51120	100	102	135	135	25	2.06	51120	-	ELP	100
51122	110	112	145	145	25	2.25	51122	-	ELP	110
51124	120	122	155	155	25	2.43	51124	-	ELP	120
51126	130	132	170	170	30	3.62	51126	-	ELP	130
51128	140	142	178	180	31	4.56	51128	-	ELP	140
51130	150	152	188	190	31	4.81	51130	-	ELP	150
51132	160	162	198	200	31	4.92	51132	-	ELP	160
51134	170	172	213	215	34	6.53	51134	-	ELP	170
51136	180	183	222	225	34	7.67	51136	-	ELP	180
51138	190	193	237	240	37	8.95	51138	-	ELP	190
51140	200	203	247	250	37	9.35	51140	-	ELP	200
51144	220	223	267	270	37	10.20	51144	-	ELP	220
51148	240	243	297	300	45	16.60	51148	-	ELP	240
51152	260	263	317	320	45	17.90	51152	-	ELP	260
51156	280	283	347	350	53	26.90	51156	-	ELP	280
51160	300	304	376	380	62	38.60	51160	-	ELP	300
51164	320	324	396	400	63	41.70	51164	-	ELP	320
51168	340	344	416	420	64	44.80	51168	-	ELP	340
51172	360	364	436	440	65	48.10	51172	-	ELP	360
51176	380	384	456	460	65	50.71	51176	-	-	-
51180	400	404	476	480	65	52.91	51180	-	-	-
51184	420	424	495	500	65	55.70	51184	-	-	-
51188	440	444	535	540	80	90.60	51188	-	-	-
51192	460	464	555	560	80	94.00	51192	-	-	-
51196	480	484	575	580	80	97.90	51196	-	-	-
511/500	500	505	595	600	80	101.70	511/500	-	-	-

COLLAR BEARINGS/FLANGETTE SERIES

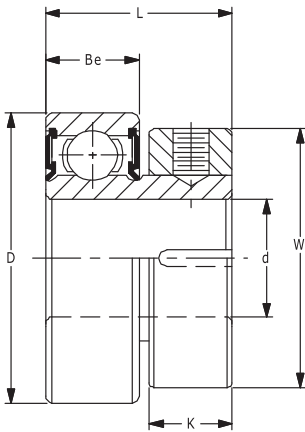

Collar Bearings Clamp Type Standard Type

Part Number	d +.0005 - .0000	D +.0000 - .0004	Be +.000 - .005	L +.000 - .005	K	W
S1PP7-4	.1875	.6250	.1960	.4219	3/16"	9/16"
S1PP7-3	.2500	.6250	.1960	.4219	3/16"	9/16"
S3PP16	.3125	.8750	.2812	.5625	1/4"	25/32"
S3PP4	.3750	.8750	.2812	.5625	1/4"	25/32"
S5PP2	.5000	1.1250	.3125	.6250	9/32"	29/32"

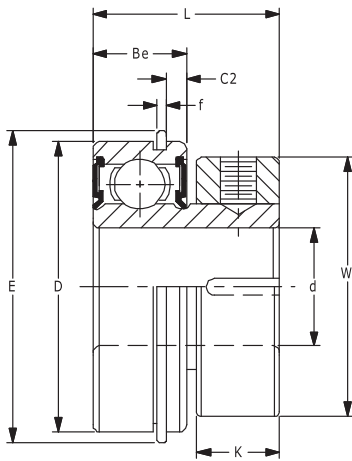

"G" Type: Snap Ring Mounted on Outer Diameter

Part Number	d +.0005 - .0000	D +.0000 - .0004	Be +.000 - .005	L +.000 - .005	K	W	C ₂	f
S1PPG7-4	.1875	.6250	.1960	.4219	3/16"	9/16"	.070	.026
S1PPG7-3	.2500	.6250	.1960	.4219	3/16"	9/16"	.070	.026
S3PPG16	.3125	.8750	.2812	.5625	1/4"	25/32"	.090	.026
S3PPG4	.3750	.8750	.2812	.5625	1/4"	25/32"	.090	.026
S5PPG2	.5000	1.1250	.3125	.6250	9/32"	29/32"	.090	.031

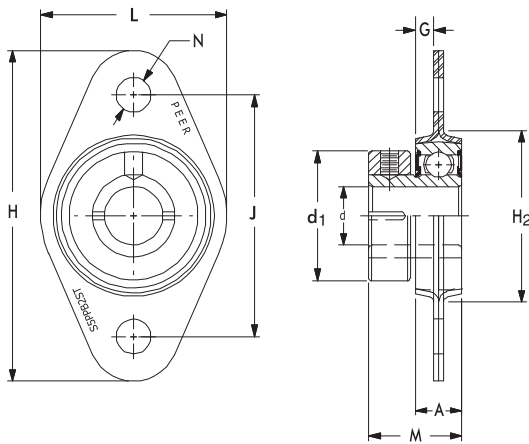

Flangette Series

1. Bearing material 52100 Chrome steel
2. House material pressed steel
3. Bearings meet ABEC 1 tolerances except bore
4. Bearing double sealed

Part Number	d +.0005 - .0000	L	J	N	M	G	d ₁	A	H ₂	H
S1PPB73ST	.2500	7/8"	1 7/32"	7/32"	.43	.079	9/16"	7/23"	25/32"	1.78125
S3PPB15ST	.3125	1 3/16	1 17/32	7/32	.562	.107	25/32	9/32	1 3/32	2 3/32
S3PPB5ST	.3750	1 3/16	1 17/32	7/32	.562	.107	25/32	9/32	1 3/32	2 3/32
S5PPB2ST	.5000	1 7/16	1 25/32	7/32	.625	.120	29/32	5/16	1 9/32	2 11/32



1200, 1200K, 1300 & 1300K SERIES

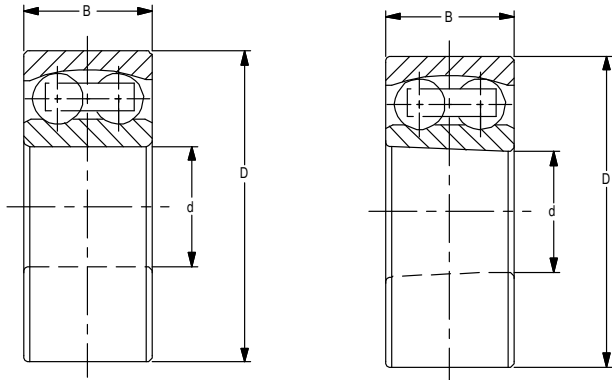

The self-aligning ball bearing is one of the double row type with a spherical raceway in the outer ring. This gives the bearing self-aligning properties and allows it to compensate for misalignment, shaft deflections and housing deformation. Self-aligning ball bearings are available with cylindrical or tapered bore 1:12.

Part Number		Bore		Outer Diameter		Width		Radius		Basic Load Rating lbs.		Weight lbs.
		d		D		B		r		Dynamic C	Static Cor	
		mm	in.	mm	in.	mm	in.	mm	in.			
1200	1200K	10	.3937	30	1.1811	9	.3543	1	.039	1230	268	0.075
1201	1201K	12	.4724	32	1.2598	10	.3937	1	.039	1260	286	0.088
1202	1202K	15	.5906	35	1.3780	11	.4331	1	.039	1680	395	0.108
1203	1203K	17	.6693	40	1.5748	12	.4724	1	.039	1770	450	0.161
1204	1204K	20	.7874	47	1.8504	14	.5512	1.5	.059	2230	585	0.265
1205	1205K	25	.9843	52	2.0472	15	.5906	1.5	.059	2720	740	0.311
1206	1206K	30	1.1811	62	2.4409	16	.6299	1.5	.059	3500	1050	0.485
1207	1207K	35	1.3780	72	2.8346	17	.6693	2	.079	3550	1150	0.712
1208	1208K	40	1.5748	80	3.1496	18	.7087	2	.079	4350	1470	0.919
1209	1209K	45	1.7717	85	3.3565	19	.7480	2	.079	4900	1650	1.03
1210	1210K	50	1.9685	90	3.5433	20	.7874	2	.079	5100	1820	1.16
1211	1211K	55	2.1654	100	3.9370	21	.8268	2.5	.098	6000	2250	1.55
1212	1212K	60	2.3622	110	4.3307	22	.8661	2.5	.098	6800	2590	1.98
1213	1213K	65	2.5591	120	4.7244	23	.9055	2.5	.098	6950	2820	2.54
1214	1214K	70	2.7559	125	4.9213	24	.9449	2.5	.098	7800	3100	2.78
1215	1215K	75	2.9528	130	4.1181	25	.9843	2.5	.098	8750	3550	3.00
1216	1216K	80	3.1496	140	5.5118	26	1.0236	3	.118	8950	3800	3.68
1217	1217K	85	3.3465	150	5.9055	28	1.1024	3	.118	11000	4650	4.56
1218	1218K	90	3.5433	160	6.2992	30	1.1811	3	.118	12800	5300	5.56
1219	1219K	95	3.7402	170	6.6929	32	1.2598	3.5	.138	14300	6100	6.83
1220	1220K	100	3.9370	180	7.0866	34	1.3386	3.5	.138	15500	6700	8.16
1300	1300K	10	.3937	35	1.3780	11	.4331	0.6	.024	1630	365	0.128
1301	1301K	12	.4724	37	1.4567	12	.4724	1	.039	2130	485	0.148
1302	1302K	15	.5906	42	1.6535	13	.5118	1.5	.059	2150	515	0.207
1303	1303K	17	.6693	47	1.8504	14	.5512	1.5	.059	2820	715	0.287
1304	1304K	20	.7874	52	2.0472	15	.5906	2	.079	2790	750	0.359
1305	1305K	25	.9843	62	2.4409	17	.6693	2	.079	4050	1130	0.567
1306	1306K	30	1.1811	72	2.8346	19	.7480	2	.079	4800	1420	0.853
1307	1307K	35	1.3780	80	3.1496	21	.8268	2.5	.098	5650	1770	1.12
1308	1308K	40	1.5748	90	3.5433	23	.9055	2.5	.098	6650	2180	1.58
1309	1309K	45	1.7717	100	3.9370	25	.9843	2.5	.098	8550	2860	2.11
1310	1310K	50	1.9685	110	4.3307	27	1.0630	3	.118	9750	3150	2.67
1311	1311K	55	2.1654	120	4.7244	29	1.1417	3	.118	11600	4000	3.48
1312	1312K	60	2.3622	130	5.1181	31	1.2205	3.5	.138	12900	4700	4.32
1313	1313K	65	2.5591	140	5.5118	33	1.2992	3.5	.138	13900	5150	5.40
1314	1314K	70	2.7559	150	5.9055	35	1.3780	3.5	.138	16700	6250	6.60
1315	1315K	75	2.9528	160	6.2992	37	1.4567	3.5	.138	17800	6750	7.85
1316	1316K	80	3.1496	170	6.6929	39	1.5354	3.5	.138	19900	7450	9.22
1317	1317K	85	3.3465	180	7.0866	41	1.6142	4	.157	22000	8500	11.00
1318	1318K	90	3.5433	190	7.4803	43	1.6929	4	.157	26100	10000	12.80
1319	1319K	95	3.7402	200	7.8740	45	1.7717	4	.157	29600	11400	14.70
1320	1320K	100	3.9370	215	8.4646	47	1.8504	4	.157	32000	12900	18.30

2200, 2200K, 2300 & 2300K SERIES

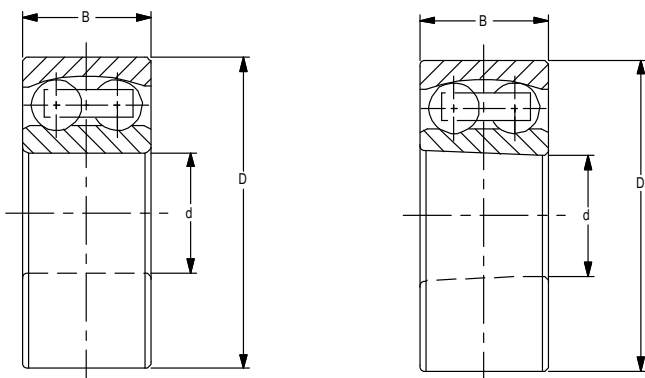

The self-aligning ball bearing is one of the double row type with a spherical raceway in the outer ring. This gives the bearing self-aligning properties and allows it to compensate for misalignment, shaft deflections and housing deformation. Self-aligning ball bearings are available with cylindrical or tapered bore 1:12.

Part Number		Bore d		Outer Diameter D		Width B		Radius r		Basic Load Rating lbs.		Weight lbs.	
		mm	in.	mm	in.	mm	in.	mm	in.	Dynamic C	Static Cor	2200	2200K
												2300	2300K
2200	2200K	10	.3937	30	1.1811	14	.5512	1	.039	1640	360	0.104	0.098
2201	2201K	12	.4724	32	1.2598	14	.5512	1	.039	1710	390	0.117	0.113
2202	2202K	15	.5906	35	1.3780	14	.5512	1	.039	1780	415	0.132	0.127
2203	2203K	17	.6693	40	1.5748	16	.6299	1	.039	2200	545	0.194	0.118
2204	2204K	20	.7874	47	1.8504	18	.7087	1.5	.059	2830	745	0.309	0.300
2205	2205K	25	.9843	52	2.0472	18	.7087	1.5	.059	2760	775	0.359	0.348
2206	2206K	30	1.1811	62	2.4409	20	.7874	1.5	.059	3400	1020	0.573	0.560
2207	2207K	35	1.3780	72	2.8346	23	.9055	2	.079	4850	1480	0.888	0.873
2208	2208K	40	1.5748	80	3.1496	23	.9055	2	.079	5000	1650	1.11	1.09
2209	2209K	45	1.7717	85	3.3565	23	.9055	2	.079	5200	1830	1.20	1.18
2210	2210K	50	1.9685	90	3.5433	23	.9055	2	.079	5200	1900	1.30	1.27
2211	2211K	55	2.1654	100	3.9370	25	.9843	2.5	.098	5920	2220	1.79	1.75
2212	2212K	60	2.3622	110	4.3307	28	1.1024	2.5	.098	7650	2840	2.40	2.36
2213	2213K	65	2.5591	120	4.7244	31	1.2205	2.5	.098	9750	3700	3.22	3.15
2214	2214K	70	2.7559	125	4.9213	31	1.2205	2.5	.098	9850	3850	3.35	-
2215	2215K	75	2.9528	130	4.1181	31	1.2205	2.5	.098	9950	4000	3.57	3.48
2216	2216K	80	3.1496	140	5.5118	33	1.2992	3	.118	10900	4450	4.43	4.34
2217	2217K	85	3.3465	150	5.9055	36	1.4173	3	.118	13100	4300	5.56	5.42
2218	2218K	90	3.5433	160	6.2992	40	1.5748	3	.118	15800	6450	7.50	7.34
2219	2219K	95	3.7402	170	6.6929	43	1.6929	3.5	.138	18700	7750	9.04	8.82
2220	2220K	100	3.9370	180	7.0866	46	1.8110	3.5	.138	21100	8650	11.0	10.70
2300	2300K	10	.3937	35	1.3780	17	.6693	1	.039	2270	485	0.183	0.180
2301	2301K	12	.4724	37	1.4567	17	.6693	1.5	.059	2640	610	0.201	0.195
2302	2302K	15	.5906	42	1.6535	17	.6693	1.5	.059	2700	650	0.251	0.245
2303	2303K	17	.6693	47	1.8504	19	.7480	1.5	.059	3250	800	0.348	0.340
2304	2304K	20	.7874	52	2.0472	21	.8268	2	.079	4050	1060	0.461	0.452
2305	2305K	25	.9843	62	2.4409	24	.9449	2	.079	5500	1480	0.739	0.721
2306	2306K	30	1.1811	72	2.8346	27	1.0630	2	.079	7050	1970	1.10	1.08
2307	2307K	35	1.3780	80	3.1496	31	1.2205	2.5	.098	8850	2530	1.49	1.45
2308	2308K	40	1.5748	90	3.5433	33	1.2992	2.5	.098	10100	3050	2.04	1.99
2309	2309K	45	1.7717	100	3.9370	36	1.4173	2.5	.098	12200	3750	2.71	2.65
2310	2310K	50	1.9685	110	4.3307	40	1.5748	3	.118	14500	4550	3.62	3.53
2311	2311K	55	2.1654	120	4.7244	43	1.6929	3	.118	16900	5400	4.63	4.52
2312	2312K	60	2.3622	130	5.1181	46	1.8110	3.5	.138	19600	6350	5.73	5.58
2313	2313K	65	2.5591	140	5.5118	48	1.8898	3.5	.138	21600	7300	7.12	6.94
2314	2314K	70	2.7559	150	5.9055	51	2.0079	3.5	.138	24600	8450	8.60	-
2315	2315K	75	2.9528	160	6.2992	55	2.1654	3.5	.138	27700	9650	10.4	10.20
2316	2316K	80	3.1496	170	6.6929	58	2.2835	3.5	.138	28800	10200	13.4	13.10
2317	2317K	85	3.3465	180	7.0866	60	2.3622	4	.157	31500	11500	15.4	15.20
2318	2318K	90	3.5433	190	7.4803	64	2.5197	4	.157	34000	12900	18.6	18.20
2319	2319K	95	3.7402	200	7.8740	67	2.6378	4	.157	37000	14500	21.6	21.10
2320	2320K	100	3.9370	215	8.4646	73	2.8740	4	.157	43000	17800	27.3	26.70



16000 SERIES DEEP GROOVE BALL

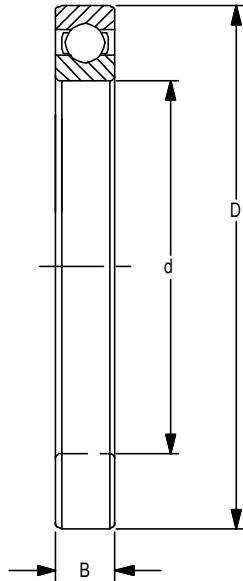

This deep groove, Conrad construction bearing is specifically designed to provide maximum performance by means of precise ball complement selection. The honed raceways offer a perfectly balanced bearing capable of operating under straight radial, thrust or combination loads. Consult PEER's engineering staff for proper selection. Stainless steel 440C material is available upon request. Radial clearance is selected in accordance to applications ranging from C2-C0-C3-C4 fits.

Part Number	Bore d	Tolerance +.0000 to minus	OD D	Tolerance +.0000 to minus	Width B	Tolerance +.0000 to minus	Basic Load Ratings lb f N		Weight lbs	Limiting Speed of Open Bearing (rpm)	
							Dynamic Cr	Static Cor		Oil	Grease
* **16100	.3937	0.0003	1.1024	0.0005	.3150	0.0050	1,030	440	0.03	34,000	29,000
16001	10 .4724	0.0003	28 1.1024	0.0005	8 .3150	0.0050	4582 1168	1957 548	0.0136	30000	26000
* **16101	12 .4724	0.0003	28 1.1811	0.0005	7 .3150	0.0050	5099 1150	2392 540	0.019	30000	26000
+16002	12 .5906	0.0003	30 1.1811	0.0005	8 .3150	0.0050	5116 1260	2402 635	0.0136	26000	22000
+16003	15 .6693	0.0003	32 1.1811	0.0005	8 .3150	0.0050	5605 1530	2825 755	0.0272	26000	22000
+16004	17 .7874	0.0004	35 1.1811	0.0005	8 .3150	0.0050	6806 2110	3359 1140	0.0317	24000	20000
16005	20 .9843	0.0004	42 1.1811	0.0005	8 .3150	0.0050	9386 2660	5071 1320	0.0498	21000	18000
16006	25 1.1811	0.0004	47 1.1811	0.0005	8 .3543	0.0050	10053 2970	5872 1860	0.0635	18000	15000
16007	30 1.3780	0.0005	55 1.3780	0.0005	9 .3543	0.0050	13212 3600	8274 2315	0.0861	15000	13000
16008	35 1.5748	0.0005	62 1.5748	0.0005	9 .3543	0.0050	16014 3750	10298 2600	0.1134	14000	12000
16009	40 1.7717	0.0005	68 1.7717	0.0005	9 .3937	0.0050	16681 4700	11566 3400	0.1270	12000	10000
16010	45 1.9685	0.0005	75 1.9685	0.0005	10 .3937	0.0050	20907 4900	15125 3750	0.1723	11000	9200
16011	50 2.1654	0.0006	80 2.1654	0.0006	10 .4331	0.0060	21797 6350	16681 4800	0.1814	9800	8400
16012	55 2.3622	0.0006	90 2.3622	0.0006	11 .4331	0.0060	28247 6610	21352 5200	0.2630	9000	7700
16013	60 2.7559	0.0006	95 2.7559	0.0006	11 .4331	0.0060	29404 6850	23132 5650	0.2812	8300	7000
16014	65 2.7559	0.0006	100 2.7559	0.0006	11 .5118	0.0060	30472 8550	25133 6950	0.2993	7700	6500
	70		110		13		38034	30916	0.4354	7100	6100

* Sizes also available with two shields (ZZ). Width Dimensions - No Change
 ** Sizes also available with two seals (2RS). Width Dimensions - No Change

16000 SERIES DEEP GROOVE BALL (continued)

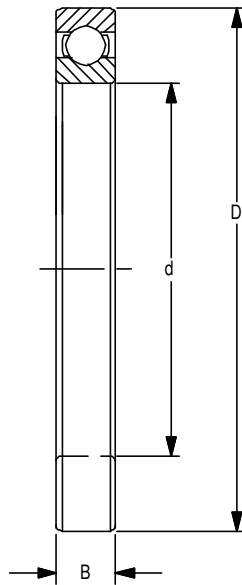

This deep groove, Conrad construction bearing is specifically designed to provide maximum performance by means of precise ball complement selection. The honed raceways offer a perfectly balanced bearing capable of operating under straight radial, thrust or combination loads. Consult PEER's engineering staff for proper selection. Stainless steel 440C material is available upon request. Radial clearance is selected in accordance to applications ranging from C2-C0-C3-C4 fits.

Part Number	Bore d	Tolerance +.0000 to minus	OD D	Tolerance +.0000 to minus	Width B	Tolerance +.0000 to minus	Basic Load Ratings lbf N		Weight lbs	Limiting Speed of Open Bearing (rpm)	
							Dynamic Cr	Static Cor		Oil	Grease
16015	2.9528	0.0006		0.0006	.5118	0.0060	8890	7550	1.01	6700	5700
	75		115		13		39456	33585	0.4581		
16016	3.1496	0.0006		0.0007	.5512	0.0060	10700	8950	1.31	6200	5300
	80		125		14		47598	39813	0.5942		
16017	3.3465	0.0006		0.0007	.5512	0.0080	11100	9700	1.38	5900	5000
	85		130		14		49377	43149	0.6259		
16018	3.5433	0.0006		0.0007	.6299	0.0080	13100	11200	1.87	5600	4700
	90		140		16		58274	49822	0.8482		
16019	3.7402	0.0006		0.0007	.6299	0.0080	13600	12100	1.95	5300	4500
	95		145		16		60498	53826	0.8845		
16020	3.9370	0.0006		0.0007	.6299	0.0080	13500	12200	2	5000	4200
	100		150		16		60053	54270	0.9072		
16021	4.1339	0.0006		0.0010	.7087	0.0080	16300	14800	2.64	4700	4000
	105		160		18		72509	65836	1.1975		
16022	4.3307	0.0006		0.0010	.7480	0.0080	18400	16400	3.21	4500	3800
	110		170		19		81851	72954	1.4560		
16024	4.7244	0.0006		0.0010	.7480	0.0080	19100	17800	3.96	4100	3500
	120		180		19		84964	79181	1.7962		
16026	5.1181	0.0009		0.0012	.8661	0.0100	23800	22700	5.92	3800	3200
	130		200		22		105872	100979	2.6853		
16028	5.5118	0.0009		0.0012	.8661	0.0100	24700	24400	6.29	3500	3000
	140		210		22		109875	108541	2.8531		
16030	5.9055	0.0009		0.0012	.9449	0.0100	28200	28200	7.88	3200	2800
	150		225		24		125445	125445	3.5743		
16032	6.2992	0.0009		0.0012	.9843	0.0100	3200	32500	9.5	3000	2600
	160		240		25		142349	144573	4.3092		
16034	6.6929	0.0009		0.0014	1.1024	0.0100	3800	38500	12.7	2800	2400
	170		260		28		169039	171263	5.7607		
16036	7.0866	0.0009		0.0014	1.2205	0.0100	42500	44500	16.7	2700	2300
	180		280		31		189057	197954	7.5751		
16038	7.4803	0.0010		0.0014	1.2205	0.0120	44000	48500	17.4	2500	2100
	190		290		31		195730	215747	7.8926		
16040	7.8740	0.0010		0.0014	1.3386	0.0120	49000	54500	22.2	2400	2000
	200		310		34		217972	242438	10.0699		



SPHERICAL O.D. "22" SERIES

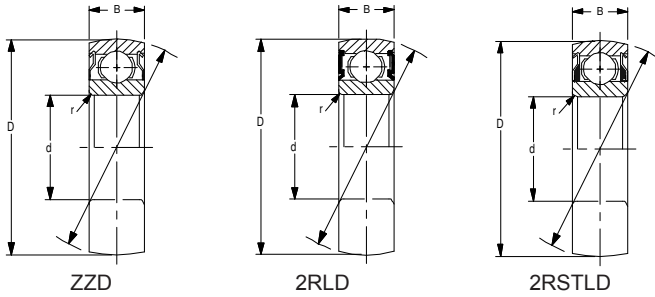

Standard Conrad series with spherical (rounded) O.D. to allow for self-aligning.

Units: Inches
Metric

Part Number	Bore d		Outer Diameter D		Width B		Radius r			Basic Load Rating		Weight lbs.
	TOL. +0/to		TOL. +0/to		TOL. +0/to		rs min	max radial	max axial	lbf	N.	
	Nominal	Minus Shown	Nominal	Minus Shown	Nominal	Minus Shown				Dynamic C	Static Cor	
6202-ZZ-22	0.5906	.0003	1.3780	.0050	.4331	.0050	.0236	.0394	.0787	1730	850	.10
6202-2RS-22	15.000	.0008	35.000	.013	11.000	.127	.600	1.000	2.000	7695	3780	.10
6202-2RST-22	0.5906	.0003	1.3780	.0050	.4331	.0050	.0236	.0394	.0787	1730	850	.10
6202-2RST-22	15.000	.0008	35.000	.013	11.000	.127	.600	1.000	2.000	7695	3780	.10
6203-ZZ-22	.6693	.0003	1.5748	.0050	.4724	.0050	.0236	.0394	.0787	2160	1000	.14
6203-2RS-22	17.000	.0008	40.000	.013	12.000	.127	.600	1.000	2.000	9608	4448	.14
6203-2RST-22	.6693	.0003	1.5748	.0050	.4724	.0050	.0236	.0394	.0787	2160	1000	.14
6203-2RST-22	17.000	.0008	40.000	.013	12.000	.127	.600	1.000	2.000	9608	4448	.14
6204-ZZ-22	.7874	.0004	1.8504	.0050	.5512	.0050	.0394	.0591	.1181	2900	1410	.23
6204-2RS-22	20.000	.010	47.000	.013	14.000	.127	1.000	1.500	3.000	12899	6271	.23
6204-2RST-22	.7874	.0004	1.8504	.0050	.5512	.0050	.0394	.0591	.1181	2900	1410	.23
6204-2RST-22	20.000	.010	47.000	.013	14.000	.127	1.000	1.500	3.000	12899	6271	.23
6205-ZZ-22	.9843	.0004	2.0472	.0050	.5906	.0050	.0394	.0591	.1181	3150	1610	.28
6205-2RS-22	25.000	.010	52.000	.013	15.000	.127	1.000	1.500	3.000	14011	7161	.28
6205-2RST-22	.9843	.0004	2.0472	.0050	.5906	.0050	.0394	.0591	.1181	3150	1610	.28
6205-2RST-22	25.000	.010	52.000	.013	15.000	.127	1.000	1.500	3.000	14011	7161	.28
6206-ZZ-22	1.1811	.0004	2.4409	.0050	.6299	.0050	.0394	.0591	.1181	4370	2320	.43
6206-2RS-22	30.000	.010	62.000	.013	16.000	.127	1.000	1.500	3.000	19438	10319	.43
6206-2RST-22	1.1811	.0004	2.4409	.0050	.6299	.0050	.0394	.0591	.1181	4370	2320	.43
6206-2RST-22	30.000	.010	62.000	.013	16.000	.127	1.000	1.500	3.000	19438	10319	.43
6207-ZZ-22	1.378	.0050	2.8346	.0050	.6693	.0050	.0433	.0787	.1378	5770	3150	.64
6207-2RS-22	35.000	.013	72.000	.013	17.000	.127	1.100	2.000	3.500	25666	14011	.64
6207-2RST-22	1.378	.0050	2.8346	.0050	.6693	.0050	.0433	.0787	.1378	5770	3150	.64
6207-2RST-22	35.000	.013	72.000	.013	17.000	.127	1.100	2.000	3.500	25666	14011	.64
6208-ZZ-22	1.5748	.0050	3.1496	.0050	.7087	.0050	.0433	.0787	.1378	7340	3650	.82
6208-2RS-22	40.000	.013	80.000	.013	18.000	.127	1.100	2.000	3.500	32649	16236	.82
6208-2RST-22	1.5748	.0050	3.1496	.0050	.7087	.0050	.0433	.0787	.1378	7340	3650	.82
6208-2RST-22	40.000	.013	80.000	.013	18.000	.127	1.100	2.000	3.500	32649	16236	.82
6209-ZZ-22	1.7717	.0050	3.3465	.0060	.7480	.0050	.0433	.0787	.1378	7350	4150	.90
6209-2RS-22	45.000	.013	85.000	.015	19.000	.127	1.100	2.000	3.500	32694	18460	.90
6209-2RST-22	1.7717	.0050	3.3465	.0060	.7480	.0050	.0433	.0787	.1378	7350	4150	.90
6209-2RST-22	45.000	.013	85.000	.015	19.000	.127	1.100	2.000	3.500	32694	18460	.90

SPHERICAL O.D. "22" SERIES (continued)

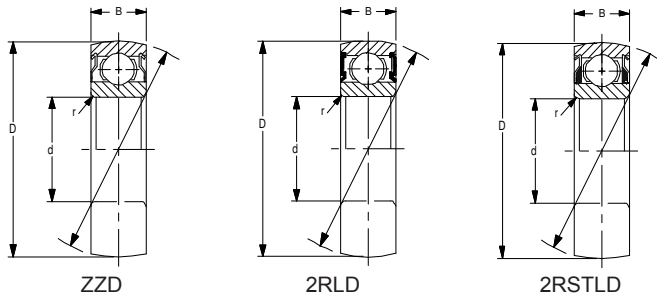

Standard Conrad series with spherical (rounded) O.D. to allow for self-aligning.

Units: Inches
Metric

Part Number	Bore d		Outer Diameter D		Width B		Radius r			Basic Load Rating		Weight lbs.
	TOL. +0/to	Minus Shown	TOL. +0/to	Minus Shown	TOL. +0/to	Minus Shown	rs min	max radial	max axial	lb f Dynamic C	N. Static Cor	
6210-ZZ-22	1.9685	.0050	3.5433	.0060	.7874	.0050	.0433	.0787	.1378	7880	4650	1.01
	50.000	.013	90.000	.015	20.000	.127	1.100	2.00	3.500	35051	20684	
6210-2RS-22	1.9685	.0050	3.5433	.0060	.7874	.0050	.0433	.0787	.1378	7880	4650	1.01
	50.000	.013	90.000	.015	20.000	.127	1.100	2.00	3.500	35051	20684	
6210-2RST-22	1.9685	.0050	3.5433	.0060	.7874	.0050	.0433	.0787	.1378	7880	4650	1.01
	50.000	.013	90.000	.015	20.000	.127	1.100	2.00	3.500	35051	20684	
6305-ZZ-22	.9843	.0004	2.4409	.0050	.6693	.0050	.0433	.0787	.1378	5000	2600	.52
	25.000	.010	62.000	.013	17.000	.127	1.100	2.00	3.500	22241	11565	
6305-2RS-22	.9843	.0004	2.4409	.0050	.6693	.0050	.0433	.0787	.1378	5000	2600	.52
	25.000	.010	62.000	.013	17.000	.127	1.100	2.00	3.500	22241	11565	
6305-2RST-22	.9843	.0004	2.4409	.0050	.6693	.0050	.0433	.0787	.1378	5000	2600	.52
	25.000	.010	62.000	.013	17.000	.127	1.100	2.00	3.500	22241	11565	
6306-ZZ-22	1.1811	.0004	2.8346	.0050	.7480	.0050	.0433	.0787	.1378	6550	3650	.78
	30.000	.010	72.000	.013	19.000	.127	1.100	2.00	3.500	29135	16236	
6306-2RS-22	1.1811	.0004	2.8346	.0050	.7480	.0050	.0433	.0787	.1378	6550	3650	.78
	30.000	.010	72.000	.013	19.000	.127	1.100	2.00	3.500	29135	16236	
6306-2RST-22	1.1811	.0004	2.8346	.0050	.7480	.0050	.0433	.0787	.1378	6550	3650	.78
	30.000	.010	72.000	.013	19.000	.127	1.100	2.00	3.500	29135	16236	
6307-ZZ-22	1.3780	.0005	3.1496	.0050	.8268	.0050	.0591	.0906	.1575	7500	4300	1.02
	35.000	.013	80.000	.013	21.000	.127	1.500	2.30	4.000	33361	19127	
6307-2RS-22	1.3780	.0005	3.1496	.0050	.8268	.0050	.0591	.0906	.1575	7500	4300	1.02
	35.000	.013	80.000	.013	21.000	.127	1.500	2.30	4.000	33361	19127	
6307-2RST-22	1.3780	.0005	3.1496	.0050	.8268	.0050	.0591	.0906	.1575	7500	4300	1.02
	35.000	.013	80.000	.013	21.000	.127	1.500	2.30	4.000	33361	19127	
6308-ZZ-22	1.5748	.0005	3.5433	.0060	.9055	.0050	.0591	.0906	.1575	9650	5600	1.41
	40.000	.013	90.000	.015	23.000	.127	1.500	2.30	4.000	42925	24910	
6308-2RS-22	1.5748	.0005	3.5433	.0060	.9055	.0050	.0591	.0906	.1575	9650	5600	1.41
	40.000	.013	90.000	.015	23.000	.127	1.500	2.30	4.000	42925	24910	
6308-2RST-22	1.5748	.0005	3.5433	.0060	.9055	.0050	.0591	.0906	.1575	9650	5600	1.41
	40.000	.013	90.000	.015	23.000	.127	1.500	2.30	4.000	42925	24910	
6309-ZZ-22	1.7717	.0005	3.9370	.0060	.9843	.0050	.0591	40.0906	.1575	12000	7100	1.89
	45.000	.013	100.000	.015	25.000	.127	1.500	2.30	4.000	53378	31582	
6309-2RS-22	1.7717	.0005	3.9370	.0060	.9843	.0050	.0591	.0906	.1575	12000	7100	1.89
	45.000	.013	100.000	.015	25.000	.127	1.500	2.30	4.000	53378	31582	
6309-2RST-22	1.7717	.0005	3.9370	.0060	.9843	.0050	.0591	.0906	.1575	12000	7100	1.89
	45.000	.013	100.000	.015	25.000	.127	1.500	2.30	4.000	53378	31582	
6310-ZZ-22	1.9685	.0005	4.3307	.0060	1.0630	.0050	.0787	.1181	.1772	14000	8500	2.45
	50.000	.013	110.000	.015	27.000	.127	2.00	3.000	4.500	62275	37809	
6310-2RS-22	1.9685	.0005	4.3307	.0060	1.0630	.0050	.0787	.1181	.1772	14000	8500	2.45
	50.000	.013	110.000	.015	27.000	.127	2.00	3.000	4.500	62275	37809	
6310-2RST-22	1.9685	.0005	4.3307	.0060	1.0630	.0050	.0787	.1181	.1772	14000	8500	2.45
	50.000	.013	110.000	.015	27.000	.127	2.00	3.000	4.500	62275	37809	

PRECISION RADIAL BALL BEARINGS

The most popular type of bearing in use today is the single row deep groove radial ball bearing. The basic function of a radial ball bearing is to transmit rotational motion without the loss of energy. To accomplish this, anti-friction bearings are generally composed of two SAE 52100 hardened steel rings separated by the balls and spaced by a retainer. The deep superfinished raceways make these bearings suitable for radial loads or a combination of radial and moderate thrust loads in either direction. This type of design combines high operating speeds and super precision tolerances.

RETAINER

The retainer used in this type of bearing evenly spaces the balls around the bearing circumference and allows them to rotate properly within the assembly. It is typically manufactured with pressed crimped steel, pressed riveted steel, molded nylon, or phenolic materials. Based on the application requirements, the appropriate retainer material can be chosen.

CLOSURES

In an effort to eliminate contaminants from entering the rotating parts, the basic bearing can be enclosed with either metal shields or steel reinforced rubber type seals. A combination of either is available and various seal materials can be used depending upon the application. Table 1 describes the seal and shield nomenclature for the most commonly used closures.

LUBRICATION

Lubrication is used in bearings to eliminate metal to metal contact and prevent premature wear of bearing components. Bearings are filled with either a lubricating grease or oil and assembled with closures. Table 22 lists commonly used greases.

RADIAL INTERNAL CLEARANCE

Radial internal clearance is defined as the internal space between the balls and rings of radial deep groove ball bearings. It is determined by design applications depending upon the temperature situations present, the amount of press fit, the bearing misalignment, noise level and speeds required.

TOLERANCE CLASS

The various tolerances and formulae used by the bearing industry today (through the efforts of the American Bearing Manufacturers Association, ABMA, and the International Standards Organization, ISO) have become nearly standard practice in bearing production. Therefore, except in isolated instances, bearing boundary dimensions and tolerances are interchangeable throughout the world.

MATERIAL

Precision anti-friction bearings are most commonly made of SAE 52100 chromium steel. This reference is to a carbon alloy steel containing approximately 1% carbon, 1.5% chromium and lesser amounts of manganese, silicon and in some instances, molybdenum. Modern methods of steel manufacturing combined with up to date heat treatment technology have greatly reduced the non-metallic inclusions. Materials are constantly being checked against Standard ASTM A295 in accordance to the Jernkontoret chart. Quenching temperatures are closely monitored to maintain a martensitic structure with the minimum amount of retained austenite. Stainless steel materials are available for many sizes. Contact your PEER Sales Engineer for availability.

LIFE AND LOAD RATINGS

The life of a bearing is determined by the number of bearing revolutions (or hours at some given constant speed) counted until there is evidence of fatigue in one of the rings or in any of the rolling elements. However, individual bearings which seem identical and operate in a group under identical conditions may not last the same length of time. In this case, rating life is determined by the number of revolutions (or hours at a given constant speed) that 90% of the group of bearings complete or exceed before the first evidence of fatigue.



TABLE 1 – SYMBOL IDENTIFICATION FOR CLOSURE DESIGN

Consult PEER sales engineering to determine the exact torque and design requirements for your specific application.

Material	PEER Symbol	Type of Lip	PEER Symbol	Torque	PEER Symbol	Type of Landing Groove	PEER Symbol
BUNA (nitrile)	R	Single	S	None	A	Notch	D
HYCAR (polyacrylic)	HR	Double	L	Low	B	UG	None
VITON (fluorelastomer)	VR	Triple	T	Standard	None	W/L	W
METAL PROTECTED SEAL	RST			High	C	Step UG	P
METAL SHIELD	Z						

BEARING TOLERANCES AND PRECISION

To ensure dimensional accuracy in measurable forms, all PEER bearings are manufactured according to the ABMA established classes. These are currently listed as ABEC-1, 3, 5 and 7 for ball bearings. All standard production PEER bearings are manufactured to a minimum of ABEC-1 tolerances. The higher the ABEC number, the higher the precision class.

ABEC-1 and 3 specify inner ring tolerances for Δd_{mp} , V_{dp} , V_{dmp} , K_{ia} , ΔE_{Bs} , V_{Bs} . And outer ring tolerances of ΔD_{mp} , V_{Dp} , V_{Dmp} , K_{ea} , ΔE_{Cs} , V_{Cs} . See Tables 2 through 5.

ABEC-5 specifies tolerances for the same characteristics as classes 1 and 3 with the addition of S_d and S_{ia} for the inner ring and S_D and S_{ea} for the outer ring.

See "Tolerance Definitions" for an explanation of these symbols.

TOLERANCE DEFINITIONS

ABMA Std. 20-1996

Bore Diameter

d	Nominal bore diameter
d_s	Single bore diameter
Δd_s	$=d_s - d$ Deviation of a single bore diameter from nominal dimension
d_{spmax}	Single plane maximum
d_{spmin}	Single plane minimum bore diameter
d_{mp}	$= \frac{d_{spmax} + d_{spmin}}{2}$ Single plane mean bore diameter
Δd_{mp}	$=d_{mp} - d$ Single plane mean bore diameter deviation
V_{dp}	$=d_{spmax} - d_{spmin}$ Bore diameter variation in a single radial plane
V_{dmp}	$=d_{mpmax} - d_{mpmin}$ Means bore diameter variation; difference between maximum and minimum mean diameter

Outside Diameter

D	Nominal outside diameter
-----	--------------------------

D_s	Single outside diameter
ΔD_s	$=D_s - D$ Deviation of a single outside diameter from nominal dimensions
D_{spmax}	Single plane maximum outside diameter
D_{spmin}	Single plane minimum diameter
D_{mp}	$= \frac{D_{spmax} + D_{spmin}}{2}$ Single plane means outside diameter
ΔD_{mp}	$=D_{mp} - D$ Single plane means outside diameter deviation
V_{Dp}	$=D_{spmax} - D_{spmin}$ Outside diameter variation in a single radial plane
V_{Dmp}	$=D_{mpmax} - D_{mpmin}$ Means outside diameter variation; difference between maximum and minimum mean outside diameter

Width

B	Nominal inner ring width
C	Nominal outer ring width
$B_s C_s$	Single ring width (inner, outer ring)
$\Delta B_s, \Delta C_s$	$=B_s - B, C_s - C$ Deviation of a single ring width (inner, outer ring) from nominal
V_{B_s}, V_{C_s}	$=B_{smax} - B_{smin}, C_{smax} - C_{smin}$ Variation of inner and outer ring width

Running Accuracy

K_{ia}	Inner ring radial runout of assembled bearing
K_{ea}	Outer ring radial runout of assembled bearing
S_d	Inner ring face runout to bore
S_D	Outer ring outside diameter surface runout to face
S_{ia}	Inner ring face runout to raceway of assembled bearing
S_{ea}	Outer ring face runout to raceway of assembled bearing

TOLERANCES OF RADIAL BALL BEARINGS

TABLE 2
PRECISION CLASS ABEC-1 — Metric

Inner Ring Unit um (.001mm)

d mm		Δ_{dmp}		V_{dp}			V_{dmp}	K_{ia}	Δ_{Bs}		V_{Bs}
				diameterseries							
over	incl.	high	low	7,8,9 max	0,1 max	2,3,4 max	max	max	high	low	max
0.6	2.5	0	-8	10	8	6	6	10	0	-40	12
2.5	10	0	-8	10	8	6	6	10	0	-120	15
10	18	0	-8	10	8	6	6	10	0	-120	20
18	30	0	-10	13	10	8	8	13	0	-120	20
30	50	0	-12	15	12	9	9	15	0	-120	20
50	80	0	-15	19	19	11	11	20	0	-150	25
80	120	0	-20	25	25	15	15	25	0	-200	25
120	180	0	-25	31	31	19	19	30	0	-250	30
180	250	0	-30	38	38	23	23	40	0	-300	30
250	315	0	-35	44	44	26	26	50	0	-350	35
315	400	0	-40	50	50	30	30	60	0	-400	40
400	500	0	-45	56	56	34	34	65	0	-450	50

Outer Ring Unit um (.001mm)

D mm		Δ_{Dmp}		V_{Dp}				V_{Dmp}	K_{ea}	Δ_{Cs}		V_{Cs}
				Open Bearings			Capped Bearings					
				diameter series								
over	incl.	high	low	7,8,9 max	0,1 max	2,3,4 max	max	max	high	low	max	
2.5	6	0	-8	10	8	6	10	6	15	Identical to Δ_{Bs} and V_{Bs} of inner ring of the same bearing		
6	18	0	-8	10	8	6	10	6	15			
18	30	0	-9	12	9	7	12	7	15			
30	50	0	-11	14	11	8	16	8	20			
50	80	0	-13	16	13	10	20	10	25			
80	120	0	-15	19	19	11	26	11	35			
120	150	0	-18	23	23	14	30	14	40			
150	180	0	-25	31	31	19	38	19	45			
180	250	0	-30	38	38	23	23	23	50			
250	315	0	-35	44	44	26		26	60			
315	400	0	-40	50	50	30		30	70			
400	500	0	-45	56	56	34		34	80			

TOLERANCES OF RADIAL BALL BEARINGS

TABLE 3
PRECISION CLASS ABEC-1 — Inch

Inner Ring

Unit .0001"

d mm		Δ_{dmp}		V_{dp}			V_{dmp}	K_{ia}	Δ_{Bs}		V_{Bs}
				diameter series							
over	incl.	high	low	7,8,9 max	0,1 max	2,3,4 max	max	max	high	low	max
0.6	2.5	0	-3	4	3	2.5	2.5	4	0	-16	4.5
2.5	10	0	-3	4	3	2.5	2.5	4	0	-47	6
10	18	0	-3	4	3	2.5	2.5	4	0	-47	8
18	30	0	-4	5	4	3	3	5	0	-47	8
30	50	0	-4.5	6	4.5	3.5	3.5	6	0	-47	8
50	80	0	-6	7.5	7.5	4.5	4.5	8	0	-59	10
80	120	0	-8	10	10	6	6	10	0	-79	10
120	180	0	-10	12	12	7.5	7.5	12	0	-98	12
180	250	0	-12	15	15	9	9	16	0	-118	12
250	315	0	-14	17	17	10	10	20	0	-138	14
315	400	0	-16	20	20	12	12	24	0	-157	16
400	500	0	-18	22	22	13	13	26	0	-177	20

Outer Ring

Unit .0001"

D mm		Δ_{Dmp}		V_{Dp}				V_{Dmp}	K_{ea}	Δ_{Cs}		V_{Cs}
				Open Bearings			Capped Bearings					
				diameter series								
over	incl.	high	low	7,8,9 max	0,1 max	2,3,4 max	max	max	high	low	max	
2.5	6	0	-3	4	3	2.5	4	2.5	6	Identical to Δ_{Bs} and V_{Bs} of inner ring of the same bearing		
6	18	0	-3	4	3	2.5	4	2.5	6			
18	30	0	-3.5	4.5	3.5	3	4.5	3	6			
30	50	0	-4.5	5.5	4.5	3	6.5	3	8			
50	80	0	-5	6.5	5	4	8	4	10			
80	120	0	-6	7.5	7.5	4.5	10	4.5	14			
120	150	0	-7	9	9	5.5	12	5.5	16			
150	180	0	-10	12	12	7.5	15	7.5	18			
180	250	0	-12	15	15	9	—	9	20			
250	315	0	-14	17	17	10	—	10	24			
315	400	0	-16	20	20	12	—	12	28			
400	500	0	-18	22	22	13	—	13	31			

TOLERANCES OF RADIAL BALL BEARINGS

TABLE 4
PRECISION CLASS ABEC-3 — Metric

Inner Ring unit μm (.001 mm)

d mm		Δ_{dmp}		V_{dp}			V_{dmp}	K_{ia}	Δ_{Bs}		V_{Bs}
				diameter series							
over	incl.	high	low	7,8,9 max	0,1 max	2,3,4 max	max	max	high	low	max
0.6	2.5	0	-7	9	7	5	5	5	0	-40	12
2.5	10	0	-7	9	7	5	5	6	0	-120	15
10	18	0	-7	9	7	5	5	7	0	-120	20
18	30	0	-8	10	8	6	6	8	0	-120	20
30	50	0	-10	13	10	8	8	10	0	-120	20
50	80	0	-12	15	15	9	9	10	0	-150	25
80	120	0	-15	19	19	11	11	13	0	-200	25
120	180	0	-18	23	23	14	14	18	0	-250	30
180	250	0	-22	28	28	17	17	20	0	-300	30
250	315	0	-25	31	31	19	19	25	0	-350	35
315	400	0	-30	38	38	23	23	30	0	-400	40
400	500	0	-35	44	44	26	26	35	0	-450	45

Outer Ring unit μm (.001 mm)

D mm		Δ_{Dmp}		V_{Dp}				V_{Dmp}	K_{ea}	Δ_{Cs}		V_{Cs}
				Open Bearings			Capped Bearings					
				diameter series								
over	incl.	high	low	7,8,9 max	0,1 max	2,3,4 max	0,1,2,3,4 max	max	max	high	low	max
2.5	6	0	-7	9	7	5	9	5	8	Identical to Δ_{Bs} and V_{Bs} of inner ring of the same bearing		
6	18	0	-7	9	7	5	9	5	8			
18	30	0	-8	10	8	6	10	6	9			
30	50	0	-9	11	9	7	13	7	10			
50	80	0	-11	14	11	8	16	8	13			
80	120	0	-13	16	16	10	20	10	18			
120	150	0	-15	19	19	11	25	11	20			
150	180	0	-18	23	23	14	30	14	23			
180	250	0	-20	25	25	15	—	15	25			
250	315	0	-25	31	31	19	—	19	30			
315	400	0	-28	35	35	21	—	21	35			
400	500	0	-33	41	41	25	—	25	40			

TOLERANCES OF RADIAL BALL BEARINGS

TABLE 5
PRECISION CLASS ABEC-3 — Inch

Inner Ring

Unit .0001"

d mm		Δ_{dmp}		V_{dp}			V_{dmp}	K_{ia}	Δ_{Bs}		V_{Bs}
				diameter series							
over	incl.	high	low	7,8,9 max	0,1 max	2,3,4 max	max	max	high	low	max
0.6	2.5	0	-3	3.5	3	2	2	2	0	-16	4.5
2.5	10	0	-3	3.5	3	2	2	2.5	0	-47	6
10	18	0	-3	3.5	3	2	2	3	0	-47	8
18	30	0	-3	4	3	2.5	2.5	3	0	-47	8
30	50	0	-4	5	4	3	3	4	0	-47	8
50	80	0	-4.5	6	6	3.5	3.5	4	0	-59	10
80	120	0	-6	7.5	7.5	4.5	4.5	5	0	-79	10
120	180	0	-7	9	9	5.5	5.5	7	0	-98	12
180	250	0	-8.5	11	11	6.5	6.5	8	0	-118	12
250	315	0	-10	12	12	7.5	7.5	10	0	-138	14
315	400	0	-12	15	15	9	9	12	0	-157	16
400	500	0	-14	17	17	10	10	14	0	-177	18

Outer Ring

Unit .0001"

D mm		Δ_{Dmp}		V_{Dp}				V_{Dmp}	K_{ea}	Δ_{Cs}		V_{Cs}
				Open Bearings			Capped Bearings					
				diameter series								
over	incl.	high	low	7,8,9 max	0,1 max	2,3,4 max	max	max	high	low	max	
2.5	6	0	-3	3.5	3	2	3.5	2	3	Identical to Δ_{Bs} and V_{Bs} of inner ring of the same bearing		
6	18	0	-3	3.5	3	2	3.5	2	3			
18	30	0	-3	4	3	2.5	4	2.5	3.5			
30	50	0	-3.5	4.5	3.5	3	5	3	4			
50	80	0	-4.5	5.5	4.5	3	6.5	3	5			
80	120	0	-5	6.5	6.5	4	8	4	7			
120	150	0	-6	7.5	7.5	4.5	10	4.5	8			
150	180	0	-7	9	9	5.5	12	5.5	9			
180	250	0	-8	10	10	6		6	10			
250	315	0	-10	12	12	7.5		7.5	12			
315	400	0	-11	14	14	8.5		8.5	14			
400	500	0	-13	16	16	10		10	16			

TOLERANCES OF RADIAL BALL BEARINGS

TABLE 6
PRECISION CLASS ABEC-5 — Metric

Inner Ring

Unit μm (.001 mm)

d mm		Δ_{dmp}		V_{dp}		V_{dmp}	K_{ia}	S_d	S_{ia}	Δ_{Bs}		V_{Bs}
				diameter series								
over	incl.	high	low	7,8,9 max	0,1,2,3,4 max	max	max	max	max	high	low	max
0.6	2.5	0	-5	5	4	3	4	7	7	0	-40	5
2.5	10	0	-5	5	4	3	4	7	7	0	-40	5
10	18	0	-5	5	4	3	4	7	7	0	-80	5
18	30	0	-6	6	5	3	4	8	8	0	-120	5
30	50	0	-8	8	6	4	5	8	8	0	-120	5
50	80	0	-9	9	7	5	5	8	8	0	-150	6
80	120	0	-10	10	8	5	6	9	9	0	-200	7
120	180	0	-13	13	10	7	8	10	10	0	-250	8
180	250	0	-15	15	12	8	10	11	13	0	-300	10
250	315	0	-18	18	14	9	13	13	15	0	-350	13
315	400	0	-23	23	18	12	15	15	20	0	-400	15

Outer Ring

Unitum (.001 mm)

D mm		Δ_{Dmp}		V_{Dp}		V_{Dmp}	K_{ea}	S_D	S_{ea}	Δ_{Cs}		V_{Cs}	
				diameter series									
over	incl.	high	low	7,8,9 max	0,1,2,3,4 max	max	max	max	max	high	low	max	
2.5	6	0	-5	5	4	3	5	8	8	Identical to Δ_{Bs} of inner ring of the same bearing		5	
6	18	0	-5	5	4	3	5	8	8				5
18	30	0	-6	6	5	3	6	8	8				5
30	50	0	-7	7	5	4	7	8	8				5
50	80	0	-9	9	7	5	8	8	10				6
80	120	0	-10	10	8	5	10	9	11				8
120	150	0	-11	11	8	6	11	10	13				8
150	180	0	-13	13	10	7	13	10	14				8
180	250	0	-15	15	11	8	15	11	15				10
250	315	0	-18	18	14	9	18	13	18				11
315	400	0	-20	20	15	10	20	13	20			13	
400	500	0	-23	23	17	12	23	15	23			15	

TOLERANCES OF RADIAL BALL BEARINGS

TABLE 7
PRECISION CLASS ABEC-5 — Inch

Inner Ring

Unit .0001"

d mm		Δ_{dmp}		V _{dp}		V _{dmp}	K _{ia}	S _d	S _{ia}	Δ_{Bs}		V _{Bs}
				diameter series								
over	incl.	high	low	7,8,9 max	0,1,2,3,4 max	max	max	max	max	high	low	max
0.6	2.5	0	-2	2	1.5	1	1.5	3	3	0	-16	2
2.5	10	0	-2	2	1.5	1	1.5	3	3	0	-16	2
10	18	0	-2	2	1.5	1	1.5	3	3	0	-31	2
18	30	0	-2.5	2.5	2	1	1.5	3	3	0	-47	2
30	50	0	-3	3	2.5	1.5	2	3	3	0	-47	2
50	80	0	-3.5	3.5	3	2	2	3	3	0	-59	2.5
80	120	0	-4	4	3	2	2.5	3.5	3.5	0	-79	3
120	180	0	-5	5	4	3	3	4	4	0	-98	3
180	250	0	-6	6	4.5	3	4	4.5	5	0	-118	4
250	315	0	-7	7	5.5	3.5	5	5	6	0	-138	5
315	400	0	-9	9	7	4.5	6	6	8	0	-157	6

Outer Ring

Unit .0001"

D mm		Δ_{Dmp}		V _{Dp}		V _{Dmp}	K _{ea}	S _D	S _{ea}	Δ_{Cs}		V _{Cs}
				diameter series								
over	incl.	high	low	7,8,9 max	0,1,2,3,4 max	max	max	max	max	high	low	max
2.5	6	0	-2	2	1.5	1	2	3	3	Identical to Δ_{Bs} of inner ring of the same bearing		2
6	18	0	-2	2	1.5	1	2	3	3			2
18	30	0	-2.5	2.5	2	1	2.5	3	3			2
30	50	0	-3	3	2	1.5	3	3	3			2.5
50	80	0	-3.5	3.5	3	2	3	3	4			3
80	120	0	-4	4	3	2	4	3.5	4.5			3
120	150	0	-4.5	4.5	3	2.5	4.5	4	5			3
150	180	0	-5	5	4	3	5	4	5.5			3
180	250	0	-6	6	4.5	3	6	4.5	6			4
250	315	0	-7	7	5.5	3.5	7	5	7			4.5
315	400	0	-8	8	6	4	8	5	8			5
400	500	0	-9	9	6.5	4.5	9	6	9			6

INTERNAL RADIAL CLEARANCE

Internal clearance between balls and raceways in ball bearings permits interference fits on the bearing rings without causing radial preload, allows unequal thermal expansion of inner and outer rings to occur without unduly affecting bearing operation, and accommodates slight misalignment of the bearing mounting. Proper internal clearance is particularly important for bearings operating at high speeds.

Radial clearance may be defined as the average diameter of the outer ring raceway, minus the average diameter of the inner ring raceway, minus twice the ball diameter. Generally, radial clearance is measured on assembled bearings by displacing the outer ring radially with respect to the inner ring under a reversing light gauge load.

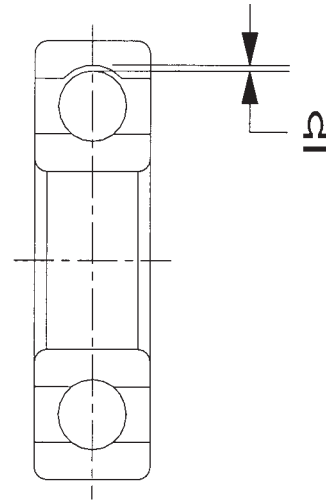

Radial Internal Clearance = Ω

TABLE 8
RADIAL INTERNAL CLEARANCE VALUES FOR SINGLE ROW RADIAL DEEP GROOVE BALL BEARINGS
 Clearance values in μm (.001 mm)

d mm		C2		C0 (Normal)		C3		C4	
over	incl.	min.	max.	min.	max.	min.	max.	min.	max.
2.5	6	0	7	2	13	8	23	—	—
6	10	0	7	2	13	8	23	14	29
10	18	0	9	3	18	11	25	18	33
18	24	0	10	5	20	13	28	20	36
24	30	1	11	5	20	13	28	23	41
30	40	1	11	6	20	15	33	28	46
40	50	1	11	6	23	18	36	30	51
50	65	1	15	8	28	23	43	38	61
65	80	1	15	10	30	25	51	46	71
80	100	1	18	12	36	30	58	53	84
100	120	2	20	15	41	36	66	61	97
120	140	2	23	18	48	41	81	71	114
140	160	2	23	18	53	46	91	81	130
160	180	2	25	20	61	53	102	91	147
180	200	2	30	25	71	63	117	107	163

Clearance values in .0001 inch

d mm		C2		C0 (Normal)		C3		C4	
over	incl.	min.	max.	min.	max.	min.	max.	min.	max.
2.5	6	0	3	1	5	3	9	—	—
6	10	0	3	1	5	3	9	6	11
10	18	0	3.5	1	7	5	10	7	13
18	24	0	4	2	8	5	11	8	14
24	30	0.5	4.5	2	8	5	11	9	16
30	40	0.5	4.5	2.5	8	6	13	11	18
40	50	0.5	4.5	2.5	9	7	14	12	20
50	65	0.5	6	3	11	9	17	15	24
65	80	0.5	6	4	12	10	20	18	28
80	100	0.5	7	4.5	14	12	23	21	33
100	120	1	8	6	16	14	26	24	38
120	140	1	9	7	19	16	32	28	45
140	160	1	9	7	21	18	36	32	51
160	180	1	10	8	24	21	40	36	58
180	200	1	12	10	28	25	46	42	64

AXIAL INTERNAL CLEARANCE VALUES FOR DOUBLE ROW ANGULAR CONTACT BALL BEARINGS

TABLE 9

Clearance values in μm (.001 mm)

d mm		C2		C0 (Normal)		C3		C4	
over	incl.	min.	max.	min.	max.	min.	max.	min.	max.
6	10	1	11	5	21	12	28	25	45
10	18	1	12	6	23	13	31	27	47
18	24	2	14	7	25	16	34	28	48
24	30	2	15	8	27	18	37	30	50
30	40	2	16	9	29	21	40	33	54
40	50	2	18	11	33	23	44	36	58
50	65	3	22	13	36	26	48	40	63
65	80	3	24	15	40	30	54	46	71
80	100	3	26	18	46	35	63	55	83
100	120	4	30	22	53	42	73	65	96
120	140	4	34	25	59	48	82	74	108

Clearance values in .0001 inch

d mm		C2		C0 (Normal)		C3		C4	
over	incl.	min.	max.	min.	max.	min.	max.	min.	max.
6	10	0	4	2	8	5	11	10	18
10	18	0	5	2	9	5	12	11	19
18	24	1	6	3	10	6	13	11	19
24	30	1	6	3	11	7	15	12	20
30	40	1	6	4	11	8	16	13	21
40	50	1	7	4	13	9	17	14	23
50	65	1	9	5	14	10	19	16	25
65	80	1	9	6	16	12	21	18	28
80	100	1	10	7	18	14	25	22	33
100	120	2	12	9	21	17	29	26	38
120	140	2	13	10	23	19	32	29	43

**TABLE 10
SELECTION OF SHAFT FIT**

Metric

Part I – DESIGN & OPERATING CONDITIONS			BALL BEARINGS		
Rotational Conditions	Inner Ring Axial Displaceability	Radial Loading	Bore d mm		Shaft Fit
			Over	Inc.	
Inner Ring Rotating (relative to load direction) or Indeterminate Load Direction		Light	0 18	18 All	h5 j6
		Normal	0 18	18 All	j5 k5
		Heavy	18 100	100 All	k5 m5
Inner Ring Stationary (relative to load direction)	Inner Ring must be easily axially displaceable	Light	All Sizes		g6
		Normal			
		Heavy			
	Inner Ring need not be easily axially displaceable	Light	All Sizes		h6
		Normal			
		Heavy			
Pure Thrust (Axial) Load			All Sizes		j6

TABLE 11

Inch

Part II – DESIGN & OPERATING CONDITIONS			BALL BEARINGS		
Rotational Conditions	Inner Ring Axial Displaceability	Radial Loading	Bore d inches		Shaft Fit
			Over	Inc.	
Inner Ring Rotating (relative to load direction) or Indeterminate Load Direction		Light	0 0.71	0.71 All	h5 j6
		Normal	0 0.71	0.71 All	j5 k5
		Heavy	0.71 3.94	3.94 All	k5 m5
Inner Ring Stationary (relative to load direction)	Inner Ring must be easily axially displaceable	Light	All Sizes		g6
		Normal			
		Heavy			
	Inner Ring need not be easily axially displaceable	Light	All Sizes		h6
		Normal			
		Heavy			
Pure Thrust (Axial) Load			All Sizes		j6

TABLE 12 — SHAFT FITS (Metric)

 Dimensions in Millimeters
 Deviations and Fits in μm (.001 mm)

d			TOLERANCE CLASSIFICATIONS													
			g6		h6		h5		j5		j6		k5		k6	
over	incl.	Deviation	Shaft Deviation	Resultant Fit	Shaft Deviation	Resultant Fit	Shaft Deviation	Resultant Fit	Shaft Deviation	Resultant Fit	Shaft Deviation	Resultant Fit	Shaft Deviation	Resultant Fit	Shaft Deviation	Resultant Fit
3	6	0 -8	-4 -12	12L 4T	0 -8	8L 8T	0 -5	5L 8T	+3 -2	2L 11T	+6 -2	2L 14T	+6 +1	1T 14T		
6	10	0 -8	-5 -14	14L 3T	0 -9	9L 8T	0 -6	6L 8T	+4 -2	2L 12T	+7 -2	2L 15T	+7 +1	1T 15T		
10	18	0 -8	-6 -17	17L 2T	0 -11	11L 8T	0 -8	8L 8T	+5 -3	3L 13T	+8 -3	3L 16T	+9 +1	1T 17T		
18	30	0 -10	-7 -20	20L 3T	0 -13	13L 10T			+5 -4	4L 15T	+9 -4	4L 19T	+11 +2	2T 21T		
30	50	0 -12	-9 -25	25L 3T	0 -16	16L 12T			+6 -5	5L 18T	+11 -5	5L 23T	+13 +2	2T 25T	+18 +2	2T 30T
50	80	0 -15	-10 -29	29L 5T	0 -19	19L 15T			+6 -7	7L 21T	+12 -7	7L 27T	+15 +2	2T 30T	+21 +2	2T 36T
80	120	0 -20	-12 -34	34L 8T	0 -22	22L 20T			+6 -9	9L 26T	+13 -9	9L 33T	+18 +3	3T 38T	+25 +3	3T 45T
120	180	0 -25	-14 -39	39L 11T	0 -25	25L 25T			+7 -11	11L 32T	+14 -11	11L 39T	+21 +3	3T 46T	+28 +3	3T 53T
180	200	0 -30	-15 -44	44L 15T	0 -29	29L 30T			+7 -13	13L 37T	+16 -13	13L 46T	+24 +4	4T 54T		
200	225	0 -30	-15 -44	44L 15T	0 -29	29L 30T			+7 -13	13L 37T	+16 -13	13L 46T	+24 +4	4T 54T		
225	250	0 -30	-15 -44	44L 15T	0 -29	29L 30T			+7 -13	13L 37T	+16 -13	13L 46T	+24 +4	4T 54T		
250	280	0 -35	-17 -49	49L 18T	0 -32	32L 35T			+7 -16	16L 42T	+16 -16	16L 51T	+27 +4	4T 62T		
280	315	0 -35	-17 -49	49L 18T	0 -32	32L 35T			+7 -16	16L 42T	+16 -16	16L 51T	+27 +4	4T 62T		
315	355	0 -40	-18 -54	54L 22T	0 -36	36L 40T			+7 -18	18L 47T	+18 -18	18L 58T	+29 +4	4T 69T		
355	400	0 -40	-18 -54	54L 22T	0 -36	36L 40T			+7 -18	18L 47T	+18 -18	18L 58T	+29 +4	4T 69T		
400	450	0 -45	-20 -60	60L 25T	0 -40	40L 45T			+7 -20	20L 52T	+20 -20	20L 65T	+32 +5	5T 77T		
450	500	0 -45	-20 -60	60L 25T	0 -40	40L 45T			+7 -20	20L 52T	+20 -20	20L 65T	+32 +5	5T 77T		

L=loose, T=tight

 Dimensions in Millimeters
 Deviations and Fits in μm (.001 mm)

d			TOLERANCE CLASSIFICATIONS											
			m5		m6		n6		p6		r6		r7	
over	incl.	Deviation	Shaft Deviation	Resultant Fit	Shaft Deviation	Resultant Fit	Shaft Deviation	Resultant Fit	Shaft Deviation	Resultant Fit	Shaft Deviation	Resultant Fit	Shaft Deviation	Resultant Fit
3	6	0 -8	+9 +4	4T 17T										
6	10	0 -8	+12 +6	6T 20T										
10	18	0 -8	+15 +7	7T 23T										
18	30	0 -10	+17 +8	8T 27T										
30	50	0 -12	+20 +9	9T 32T	+25 +9	9T 37T								
50	80	0 -15	+24 +11	11T 39T	+30 +11	11T 45T	+39 +20	20T 54T						
80	120	0 -20	+28 +13	13T 48T	+35 +13	13T 55T	+45 +23	23T 65T	+59 +37	37T 79T				
120	180	0 -25	+33 +15	15T 58T	+40 +15	15T 65T	+52 +27	27T 77T	+68 +43	43T 93T	+90 +65	65T 115T		
180	200	0 -30	+37 +17	17T 67T	+46 +17	17T 76T	+60 +31	31T 90T	+79 +50	50T 109T	+106 +77	77T 136T		
200	225	0 -30	+37 +17	17T 67T	+46 +17	17T 76T	+60 +31	31T 90T	+79 +50	50T 109T	+109 +80	80T 139T	+126 +80	80T 156T
225	250	0 -30	+37 +17	17T 67T	+46 +17	17T 76T	+60 +31	31T 90T	+79 +50	50T 109T	+113 +84	84T 143T	+130 +84	84T 160T
250	280	0 -35	+43 +20	20T 78T	+52 +20	20T 87T	+66 +34	34T 101T	+88 +56	56T 123T	+126 +94	94T 161T	+146 +94	94T 181T
280	315	0 -35	+43 +20	20T 78T	+52 +20	20T 87T	+66 +34	34T 101T	+88 +56	56T 123T	+130 +98	98T 165T	+150 +98	98T 185T
315	355	0 -40	+46 +21	21T 86T	+57 +21	21T 97T	+73 +37	37T 113T	+98 +62	62T 138T	+144 +108	108T 184T	+165 +108	108T 205T
355	400	0 -40	+46 +21	21T 86T			+73 +37	37T 113T	+98 +62	62T 138T	+150 +114	114T 190T	+171 +114	114T 211T
400	450	0 -45	+50 +23	23T 95T			+80 +40	40T 125T	+108 +68	68T 153T	+166 +126	126T 211T	+189 +126	126T 234T
450	500	0 -45	+50 +23	23T 95T			+80 +40	40T 125T	+108 +68	68T 153T	+172 +132	132T 217T	+195 +132	132T 240T

L=loose, T=tight



TABLE 13 — SHAFT FITS (INCH)

Dimensions in inches
Deviations and Fits in .0001 inches

d			TOLERANCE CLASSIFICATIONS													
			g6		h6		h5		j5		j6		k5		k6	
over	incl.	Deviation	Shaft Deviation	Resultant Fit	Shaft Deviation	Resultant Fit	Shaft Deviation	Resultant Fit	Shaft Deviation	Resultant Fit	Shaft Deviation	Resultant Fit	Shaft Deviation	Resultant Fit	Shaft Deviation	Resultant Fit
0.1181		0	-2	5L	0	3L	0	2L	+1	1L	+2	1L	+2	0T		
	0.2362	-3	-5	1T	-3	3T	-2	3T	-1	4T	-1	5T	0	5T		
0.2362		0	-2	6L	0	4L	0	2L	+2	1L	+3	1L	+3	0T		
	0.3937	-3	-6	1T	-4	3T	-2	3T	-1	5T	-1	6T	0	6T		
0.3937		0	-2	7L	0	4L	0	3L	+2	1L	+3	1L	+4	0T		
	0.7087	-3	-7	1T	-4	3T	-3	3T	-1	5T	-1	6T	0	7T		
0.7087		0	-3	8L	0	5L			+2	2L	+4	2L	+4	1T		
	1.1811	-4	-8	1T	-5	4T			-2	6T	-2	8T	+1	8T		
1.1811		0	-4	10L	0	67L			+2	2L	+4	2L	+5	1T	+7	1T
	1.9685	-4.5	-10	0.5T	-6	4.5T			-2	6.5T	-2	8.5T	+1	9.5T	+1	11.5T
1.9685		0	-4	11L	0	7L			+2	3L	+5	3L	+6	1T	+8	1T
	3.1496	-6	-11	2T	-7	6T			-3	8T	-3	11T	+1	12T	+1	14T
3.1496		0	-5	13L	0	9L			+2	4L	+5	4L	+7	1T	+10	1T
	4.7244	-8	-13	3T	-9	8T			-4	10T	-4	13T	+1	15T	+1	18T
4.7244		0	-6	15L	0	10L			+3	4L	+6	4L	+8	1T	+11	1T
	7.0866	-10	-15	4T	-10	10T			-4	13T	-4	16T	+1	18T	+1	21T
7.0866		0	-6	17L	0	11L			+3	5L	+6	5L	+9	2T		
	7.8740	-12	-17	6T	-11	12T			-5	15T	-5	18T	+2	21T		
7.8740		0	-6	17L	0	11L			+3	5L	+6	5L	+9	2T		
	8.8583	-12	-17	6T	-11	12T			-5	15T	-5	18T	+2	21T		
8.8583		0	-6	17L	0	11L			+3	5L	+6	5L	+9	2T		
	9.8425	-12	-17	6T	-11	12T			-5	15T	-5	18T	+2	21T		
9.8425		0	-7	19L	0	13L			+3	6L	+6	6L	+11	2T		
	11.0236	-14	-19	7T	-13	14T			-6	17T	-6	20T	+2	25T		
11.0236		0	-7	19L	0	13L			+3	6L	+6	6L	+11	2T		
	12.4015	-14	-19	7T	-13	14T			-6	17T	-6	20T	+2	25T		
12.4015		0	-7	21L	0	14L			+3	7L	+7	7L	+11	2T		
	13.9763	-16	-21	9T	-14	16T			-7	19T	-6	23T	+2	27T		
13.9763		0	-7	21L	0	14L			+3	7L	+7	7L	+11	2T		
	15.7480	-16	-21	9T	-14	16T			-7	19T	-7	23T	+2	27T		
15.7480		0	-8	24L	0	16L			+3	8L	+8	8L	+13	2T		
	17.7165	-18	-24	10T	-16	18T			-8	21T	-8	26T	+2	31T		
17.7165		0	-8	24L	0	16L			+3	8L	+8	8L	+13	2T		
	19.6850	-18	-24	10T	-16	18T			-8	21T	-8	26T	+2	31T		

L=loose, T=tight

TABLE 13 (Inch continued)

Dimensions in Inches
Deviations and Fits in .0001 Inches

d			TOLERANCE CLASSIFICATIONS											
			m5		m6		n6		p6		r6		r7	
over	incl.	Deviation	Shaft Deviation	Resultant Fit	Shaft Deviation	Resultant Fit	Shaft Deviation	Resultant Fit	Shaft Deviation	Resultant Fit	Shaft Deviation	Resultant Fit	Shaft Deviation	Resultant Fit
0.1181		0	+4	2T										
	0.2362	-3	+2	7T										
0.2362		0	+5	2T										
	0.3937	-3	+2	8T										
0.3937		0	+6	3T										
	0.7087	-3	+3	9T										
0.7087		0	+7	3T										
	1.1811	-4	+3	11T										
1.1811		0	+8	4T	+10	4T								
	1.9685	-4.5	+4	12.5T	+4	14.5T								
1.9685		0	+9	4T	+12	4T	+15	8T						
	3.1496	-6	+4	15T	+4	18T	+8	21T						
3.1496		0	+11	5T	+14	5T	+18	9T	+23	15T				
	4.7244	-8	+5	19T	+5	22T	+9	26T	+15	31T				
4.7244		0	+13	6T	+16	6T	+20	11T	+27	17T	+35	26T		
	7.0866	-10	+6	23t	+6	26T	+11	20T	+17	37T	+26	45T		
7.0866		0	+15	7T	+18	7T	+24	12T	+31	20T	+42	30T		
	7.8740	-12	+7	27T	+7	30T	+12	36T	+20	43T	+30	54T		
7.8740		0	+15	7T	+18	7T	+24	12T	+31	20T	+43	31T	+50	31T
	8.8583	-12	+7	27T	+7	30T	+12	36T	+20	43T	+31	55T	+31	62T
8.8583		0	+15	7T	+18	7T	+24	12T	+31	20T	+44	33T	+51	33T
	9.8425	-12	+7	27T	+7	30T	+12	36T	+20	43T	+33	56T	+33	63T
9.8425		0	+17	8T	+20	8T	+26	13T	+35	22T	+50	37T	+57	37T
	11.0236	-14	+8	31T	+8	34T	+13	40T	+22	49T	+37	64T	+37	71T
11.0236		0	+17	8T	+20	8T	+26	13T	+35	22T	+51	39T	+59	39T
	12.4015	-14	+8	31T	+8	34T	+13	40T	+22	49T	+39	65T	+39	73T
12.4015		0	+18	8T	+22	8T	+29	15T	+39	24T	+57	43T	+65	43T
	13.9763	-16	+8	34T	+8	38T	+15	45T	+24	55T	+43	73T	+43	81T
13.9763		0	+18	8T			+29	15T	+39	24T	+59	45T	+67	45T
	15.7480	-16	+8	34T			+15	45T	+24	55T	+45	75T	+45	83T
15.7480		0	+20	9T			+31	16T	+43	27T	+65	50T	+74	50T
	17.7165	-18	+9	38T			+16	49T	+27	61T	+50	83T	+50	92T
17.7165		0	+20	9T			+31	16T	+43	27T	+68	52T	+77	52T
	19.6850	-18	+9	38T			+16	49T	+27	61T	+52	86T	+52	95T

L=loose, T=tight

TABLE 14 — SELECTION OF HOUSING FIT

DESIGN & OPERATING CONDITIONS				
Rotational Conditions	Loading	Other Conditions	Outer Ring Axial Displaceability	HOUSING FIT
Outer Ring Stationary (relative to load direction)	Light	Heat input through shaft	Outer ring easily axially displaceable	G7
	Normal or Heavy	Housing split axially		H7
		Housing not split axially		H6
	Shock with temporary complete unloading		Transitional Range	J6
Light		K6		
Indeterminate Load Direction	Normal or Heavy	Split Housing not recommended		M6
	Heavy shock			N6
Outer Ring Rotating (relative to load direction)	Light Normal or Heavy		Outer ring not easily axially displaceable	
	Heavy	Thin wall housing not split		P6

TABLE 15 — HOUSING FITS (Metric)

Dimensions in Millimeters
Deviations and Fits in um (.001 mm)

D			PART 1 – TOLERANCE CLASSIFICATIONS															
			F7		G7		H8		H7		H6		J6		J7		K6	
over	incl.	Deviation	Housing Deviation	Resultant Fit	Housing Deviation	Resultant Fit	Housing Deviation	Resultant Fit	Housing Deviation	Resultant Fit	Housing Deviation	Resultant Fit	Housing Deviation	Resultant Fit	Housing Deviation	Resultant Fit	Housing Deviation	Resultant Fit
10	18	0 -8	+16 +34	42L 16L	+6 +24	32L 6L	0 +27	35L 0	0 +18	26L 0	0 +11	19L 0	-5 +6	14L 5T	-8 +10	18L 8T	-9 +2	10L 9T
18	30	0 -9	+20 +41	50L 20L	+7 +28	37L 7L	0 +33	42L 0	0 +21	30L 0	0 +13	22L 0	-5 +8	17L 5T	-9 +12	21L 9T	-11 +2	11L 11T
30	50	0 -11	+25 +50	61L 25L	+9 +34	45L 9L	0 +39	50L 0	0 +25	36L 0	0 +16	27L 0	-6 +10	21L 6T	-11 +14	25L 11T	-13 +3	14L 13T
50	80	0 -13	+30 +60	73L 30L	+10 +40	53L 10L	0 +46	59L 0	0 +30	43L 0	0 +19	32L 0	-6 +13	26L 6T	-12 +18	31L 12T	-15 +4	17L 15T
80	120	0 -15	+36 +71	86L 36L	+12 +47	62L 12L	0 +54	69L 0	0 +35	50L 0	0 +22	37L 0	-6 +16	31L 6T	-13 +22	37L 13T	-18 +4	19L 18T
120	150	0 -18	+43 +83	101L 43L	+14 +54	72L 14L	0 +63	81L 0	0 +40	58L 0	0 +25	43L 0	-7 +18	36L 7T	-14 +26	44L 14T	-21 +4	22L 21T
150	180	0 -25	+43 +83	108L 43L	+14 +54	79L 14L	0 +63	88L 0	0 +40	65L 0	0 +25	50L 0	-7 +18	43L 7T	-14 +26	51L 14T	-24 +4	29L 21T
180	250	0 -30	+50 +96	126L 50L	+15 +61	91L 15L	0 +72	102L 0	0 +46	76L 0	0 +29	59L 0	-7 +22	52L 7T	-16 +30	60L 16T	-24 +5	35L 24T
250	315	0 -35	+56 +108	143L 56L	+17 +69	104L 17L	0 +81	116L 0	0 +52	87L 0	0 +32	67L 0	-7 +25	60L 7T	-16 +36	71L 16T	-27 +5	40L 27T
315	400	0 -40	+62 +119	159L 62L	+18 +75	115L 18L	0 +89	129L 0	0 +57	97L 0	0 +36	76L 0	-7 +29	69L 7T	-18 +39	79L 18T	-29 +7	47L 29T
400	500	0 -45	+68 +131	176L 68L	+20 +83	128L 20L	0 +97	142L 0	0 +63	108L 0	0 +40	85L 0	-7 +33	78L 7T	-20 +43	88L 20T	-30 +8	53L 32T

L=loose, T=tight

Dimensions in Millimeters
Deviations and Fits in um (.001 mm)

D			TOLERANCE CLASSIFICATIONS													
			K7		M6		M7		N6		N7		P6		P7	
over	incl.	Deviation	Housing Deviation	Resultant Fit	Housing Deviation	Resultant Fit	Housing Deviation	Resultant Fit	Housing Deviation	Resultant Fit	Housing Deviation	Resultant Fit	Housing Deviation	Resultant Fit	Housing Deviation	Resultant Fit
10	18	0 -8	-12 +6	14L 12T	-15 -4	4L 15T	-18 0	8L 18T	-20 -9	1T 20T	-23 -5	3L 23T	-26 -15	7T 26T	-29 -11	3T 29T
18	30	0 -9	-15 +6	15L 15T	-17 -4	5L 17T	-21 0	9L 21T	-24 -11	2T 24T	-28 -7	2L 28T	-31 -18	9T 31T	-35 -14	5T 35T
30	50	0 -11	-18 +7	18L 18T	-20 -4	7L 20T	-25 0	11L 25T	-28 -12	1T 28T	-33 -8	3L 33T	-37 -21	10T 37T	-42 -17	6T 42T
50	80	0 -13	-21 +9	22L 21T	-24 -5	8L 24T	-30 0	13L 30T	-33 -14	1T 33T	-39 -9	4L 39T	-45 -26	13T 45T	-51 -21	8T 51T
80	120	0 -15	-25 +10	25L 25T	-28 -6	9L 28T	-35 0	15L 35T	-38 -16	1T 38T	-45 -10	5L 45T	-52 -30	15T 52T	-59 -24	9T 59T
120	150	0 -18	-28 +12	30L 28T	-33 -8	10L 33T	-40 0	18L 40T	-45 -20	2T 45T	-52 -12	6L 52T	-61 -36	18T 61T	-68 -28	10T 68T
150	180	0 -25	-28 +12	37L 28T	-33 -8	17L 33T	-40 0	25L 40T	-45 -20	5L 45T	-52 -12	13L 52T	-61 -36	11T 61T	-68 -28	3T 68T
180	250	0 -30	-33 +13	43L 33T	-37 -8	22L 37T	-46 0	30L 46T	-51 -22	8L 51T	-60 -14	16L 60T	-70 -41	11T 70T	-79 -33	3T 79T
250	315	0 -35	-36 +16	51L 36T	-41 -9	26L 41T	-52 0	35L 52T	-57 -25	10L 57T	-66 -14	21L 66T	-79 -47	12T 79T	-88 -36	1T 88T
315	400	0 -40	-40 +17	57L 40T	-46 -10	30L 46T	-57 0	40L 57T	-62 -26	14L 62T	-73 -16	24L 73T	-87 -51	11T 87T	-98 -41	1T 98T
400	500	0 -45	-45 +18	63L 45T	-50 -10	35L 50T	-63 0	45L 63T	-67 -27	18L 67T	-80 -17	27L 80T	-95 -55	10T 95T	-108 -45	0 108T

L=loose, T=tight



TABLE 16 — HOUSING FITS (Inch)

Dimensions in Inches
Deviations and Fits in .0001 Inches

D			PART 2 – TOLERANCE CLASSIFICATIONS															
			F7		G7		H8		H7		H6		J6		J7		K6	
over	incl.	Deviation	Housing Deviation	Resultant Fit	Housing Deviation	Resultant Fit	Housing Deviation	Resultant Fit	Housing Deviation	Resultant Fit	Housing Deviation	Resultant Fit	Housing Deviation	Resultant Fit	Housing Deviation	Resultant Fit	Housing Deviation	Resultant Fit
0.3937	0.7087	0	+6	16L	+2	12L	0	14L	0	10L	0	7L	-2	5L	-3	7L	-4	4L
			-3	+13	6L	+9	2L	+11	0	+7	0	0	+2	2T	+4	3T	+1	4T
0.7087	1.1811	0	+8	19.5L	+3	14.5L	0	16.5L	0	11.5L	0	8.5L	-2	6.5L	-4	8.5L	-4	4.5L
			-3.5	+16	8L	+11	3L	+13	0	+8	0	+5	0	+3	2T	+5	4T	+1
1.1811	1.9685	0	+10	24.5L	+4	17.5L	0	19.5L	0	14.5L	0	10.5L	-2	8.5L	-4	10.5L	-5	5.5L
			-4.5	+20	10L	+13	4L	+15	0	+10	0	+6	0	+4	2T	+6	4T	+1
1.9685	3.1496	0	+12	29L	+4	21L	0	23L	0	17L	0	12L	-2	10L	-5	12L	-6	7L
			-5	+24	12L	+16	4L	+18	0	+12	0	+7	0	+5	2T	+7	5T	+2
3.1496	4.7244	0	+14	34L	+5	25L	0	27L	0	20L	0	15L	-2	12L	-5	15L	-7	8L
			-6	+28	14L	+19	5L	+21	0	+14	0	+9	0	+6	2T	+9	5T	+2
4.7244	5.9055	0	+17	40L	+6	28L	0	32L	0	23L	0	17L	-3	14L	-6	17L	-8	9L
			-7	+33	17L	+21	6L	+25	0	+16	0	+10	0	+7	3T	+10	6T	+2
5.9055	7.0866	0	+17	43L	+6	31L	0	35L	0	26L	0	20L	-3	17L	-6	20L	-8	12L
			-10	+33	17L	+21	6L	+25	0	+16	0	+10	0	+7	3T	+10	6T	+2
7.0866	9.8425	0	+20	50L	+6	36L	0	40L	0	30L	0	23L	-3	21L	-6	24L	-9	14L
			-12	+38	20L	+24	6L	+28	0	+18	0	+11	0	+9	3T	+12	6T	+2
9.8425	12.4016	0	+22	57L	+7	41L	0	46L	0	34L	0	27L	-3	24L	-6	28L	-11	16L
			-14	+43	22L	+27	7L	+32	0	+20	0	+13	0	+10	3T	+14	6T	+2
12.4016	15.7480	0	+24	63L	+7	46L	0	51L	0	38L	0	30L	-3	27L	-7	31L	-11	19L
			-16	+47	24L	+30	7L	+35	0	+22	0	+14	0	+11	3T	+15	7T	+2
15.7480	19.6850	0	+27	70L	+8	51L	0	56L	0	43L	0	34L	-3	31L	-8	35L	-13	21L
			-18	+52	27L	+33	8L	+38	0	+25	0	+16	0	+13	3T	+17	8T	+3

L=loose, T=tight

Dimensions in Inches
Deviations and Fits in .0001 Inches

D			TOLERANCE CLASSIFICATIONS													
			K7		M6		M7		N6		N7		P6		P7	
over	incl.	Deviation	Housing Deviation	Resultant Fit	Housing Deviation	Resultant Fit	Housing Deviation	Resultant Fit	Housing Deviation	Resultant Fit	Housing Deviation	Resultant Fit	Housing Deviation	Resultant Fit	Housing Deviation	Resultant Fit
0.3937	0.7087	0	-5	5L	-6	1L	-7	3L	-8	1T	-9	1L	-10	3T	-11	1T
			-3	+2	5T	-2	6T	0	7T	-4	9T	-2	9T	-6	10T	-4
0.7087	1.1811	0	-6	5L	-7	1.5L	-8	3.5L	-9	.05T	-11	0.5L	-12	3.5T	-14	2.5T
			-3.5	+2	6T	-2	7T	0	8T	-4	9T	-3	11T	-7	12T	-6
1.1811	1.9685	0	-7	7.5L	-8	2.5L	-10	4.5L	-11	0.5T	-13	1.5L	-15	3.5T	-17	2.5T
			-4.5	+3	7T	-2	8T	0	10T	-5	11T	-3	13T	-8	15T	-7
1.9685	3.1496	0	-8	9L	-9	3L	-12	5L	-13	1T	-15	1L	-18	5T	-20	3T
			-5	+4	8T	-2	9T	0	12T	-6	13T	-4	15T	-10	18T	-28
3.1496	4.7244	0	-10	10L	-11	4L	-14	6L	-15	0	-18	2L	-20	6T	-23	3T
			-6	+4	10T	-2	11T	0	14T	-6	15T	-4	18T	-12	20T	-9
4.7244	5.9055	0	-11	12L	-13	4L	-16	7L	-18	1T	-20	2L	-24	7T	-27	4T
			-7	+5	11T	-3	13T	0	16T	-8	18T	-5	20T	-14	24T	-11
5.9055	7.0866	0	-11	15L	-13	7L	-16	10L	-18	2L	-20	5L	-24	4T	-27	1T
			-10	+5	11T	-3	13T	0	16T	-8	18T	-5	20T	-14	24T	-11
7.0866	9.8425	0	-13	17L	-15	9L	-19	12L	-20	3L	-24	6L	-28	4T	-31	1T
			-12	+5	13T	-3	15T	0	18T	-9	20T	-6	24T	-16	28T	-13
9.8425	12.4016	0	-14	20L	-16	10L	-20	14L	-22	4L	-26	8L	-31	5T	-35	0
			-14	+6	14T	-4	16T	0	20T	-10	22T	-6	26T	-19	31T	-14
12.4016	15.7480	0	-16	23L	-18	12L	-22	16L	-24	6L	-29	10L	-34	4T	-39	0
			-16	+7	16T	-4	18T	0	22T	-10	24T	-6	29T	-20	34T	-16
15.7480	19.6850	0	-18	25L	-20	14L	-25	18L	-26	7L	-31	11L	-37	4T	-43	0
			-18	+7	18T	-4	20T	0	25T	-11	26T	-7	31T	-22	37T	-18

L=loose, T=tight

LOAD CAPACITY AND LIFE

Choose a PEER bearing to be used for an application on the basis of its load carrying capacity in relation to the loads to be carried, its operation speed and the requirements regarding life and reliability. A numerical value termed BASIC LOAD RATING is used in the calculations to express the load carrying capacity. Values for the dynamic radial load rating (Cr) are shown on the bearing pages.

1) Basic Load Rating

The basic load rating (Cr) is used for calculations involving dynamically stressed bearings, when selecting a bearing which is to rotate under load. It expresses the bearing radial load which will give a basic rating life of 1,000,000 revolutions (33-1/3 R.P.M. for 500 hours).

2) Life

The life of an individual bearing is defined as the number of revolutions which the bearing is capable of enduring before fatigue occurs on one of its raceways or balls.

Dynamic load ratings are based on the life that 90% of a group of identical bearings can be expected to reach or exceed. The majority of PEER bearings attain much longer life than this. The average life is approximately five times the calculated life rating.

2.1) The Life Calculation under Radial Load

The relationship between the basic rating life, the basic dynamic load rating and the bearing load is expressed by the equation:

$$L_{10} = \left(\frac{C_r}{P}\right)^p$$

Where

L_{10} = basic rating life in millions of revolutions

C_r = Basic dynamic radial load rating, Lbf.

P = equivalent dynamic radial bearing load, Lbf.

p = 3 for ball bearings

For bearings operating at constant speed a basic catalog life expressed in operating hours uses the equation:

$$L_{10h} = \left(\frac{C_r}{P}\right)^3 \frac{16,667}{n}$$

Where

L_{10h} = basic life in operating hours

n = rotational speed, rpm.

The basic rating life L_{10} or L_{10h} should be used when selecting a bearing size. If the load is constant in magnitude and direction and acts radially on a bearing, then $P=Fr$ and the load may be inserted directly in the life equation.

Example 1: Determining L_{10h} Life:

A 6205 bearing is operating at 700 RPM with a radial load (F_r) of 350 lbf. What is the life (L_{10})?

From page 10 we know that a 6205 bearing has a dynamic load rating (C_r) of 3150 lbf.

Therefore:

$$L_{10} = \left(\frac{C_r}{P}\right)^3 \frac{16,667}{n} = \left(\frac{3150}{350}\right)^3 \frac{16,667}{700} = (729) \frac{16,667}{700} = 17,000 \text{ hours}$$

Example 2: Selecting a bearing

A bearing is required to run at a speed of $N = 2000$ RPM under a constant radial load (F_r) of 674 Lbf and to achieve a basic rating life L_{10h} of 15,000 operating hours. What C_r is required?

$$C_r = P \sqrt[3]{\frac{L_{10} \times n}{16,667}} = 674 \sqrt[3]{\frac{15,000 \times 2,000}{16,667}} = 8,200 \text{ Lbf.}$$

Example 3: Finding Maximum Load:

A 6204 bearing must achieve a L_{10h} of 10,000 hours while operating at 15000 RPM. What is the maximum load (P) this bearing can be subjected to?

$$P = \sqrt[3]{\frac{C_r}{L_{10} \times n}} = \sqrt[3]{\frac{2900}{10,000 \times 1,500}} = \sqrt[3]{\frac{2900}{900}} = \frac{2900}{9.65} = 300 \text{ Lbf.}$$

2.2) The Life Calculation under combined Axial and Radial Load

In cases of combined radial and axial loading, it is necessary to calculate the equivalent dynamic radial bearing load (P). This is defined as a hypothetical load, constant in magnitude and direction, acting radially on the radial bearing, which would have the same influence on the bearing life as the actual loads which the bearing is to be subjected. Assuming constant load, it is $P = xF_r + YF_a$ where F_r and F_a are the radial and axial loads, respectively. The factors x and y vary depending on the $\frac{F_a}{C_{or}}$ and $\frac{F_a}{F_r}$ ratios.

Table 17: Radial and Thrust Factors X and Y for Determining the Equivalent Dynamic Radial Load for ball bearings

$\frac{F_a}{C_{or}}$	e	$\frac{F_a}{F_r} \leq e$		$\frac{F_a}{F_r} > e$	
		X	Y	X	Y
0.014	0.19				2.30
0.028	0.22				1.99
0.056	0.26				1.71
0.084	0.28				1.55
0.11	0.30	1	0	0.56	1.45
0.17	0.34				1.31
0.28	0.38				1.15
0.42	0.42				1.04
0.56	0.44				1.00

Equivalent Dynamic Radial Load = $P = XF_r + YF_a$

$P_o = .6F_r + .5F_a$ when $F_a/F_r > .8$.

$P_o = F_r$ when $F_a/F_r \leq .8$.

Example 4: Determining Equivalent Dynamic Radial Load Based on Combined Axial and Radial Load

A 6206 bearing is operating at 1000 rpm with a radial load (F_r) of 500 lbs and an axial load (F_a) of 279 lbs. What is the life (L_{10h})?

Step 1: Determine thrust factors X and Y:

$$\frac{F_a}{C_{or}} = \frac{279 \text{ lbs}}{2540 \text{ lbs}} = .11 \text{ (using table 16, } e = .30)$$

$$\frac{F_a}{F_r} = \frac{279 \text{ lbs}}{500 \text{ lbs}} = .558$$

$$\frac{F_a}{F_r} \leq e$$

Therefore, (using table 16, $X = .56$ $Y = 1.45$)

Step 2: Calculate Equivalent Dynamic Radial Load (P)

$$P = XF_r + YF_a = (.56) 500 \text{ lbs} + (1.45) 279 \text{ lbs} = 685 \text{ lbs}$$

Step 3: Calculate L_{10h}

$$L_{10h} = \left(\frac{C_r}{P}\right)^3 \frac{16,667}{n} = \left(\frac{4400}{685}\right)^3 \frac{16,667}{1000} = 4417 \text{ hrs}$$

2.3 Determining Equivalent Dynamic Load Based on Load Conditions

In applications with a constant speed, where the load grows linearly from a minimum value ($P_{min.}$) to a maximum ($P_{max.}$), then drops back to the minimum value, the average load is:

$$P = \frac{P_{min} + 2P_{max}}{3}$$

Where P = Equivalent dynamic bearing load in lbs.

When a bearing is subjected to variable load and speed conditions, the equivalent constant load P can be calculated by:

$$P = \sqrt[3]{\frac{(P_1^3 \times n_1 \times t_1) + (P_2^3 \times n_2 \times t_2) + \dots + (P_n^3 \times n_n \times t_n)}{(n_1 \times t_1) + (n_2 \times t_2) + \dots + (n_n \times t_n)}}$$

Where P_1 = constant load at n_1 RPM for t_1 minutes
 P_2 = constant load at n_2 RPM for t_2 minutes
 P_n = constant load at n_n RPM for t_n minutes

When a bearing is subjected to variable load but constant speed, the equivalent constant load P can be calculated by:

$$P = \sqrt[3]{\frac{(P_1^3 \times t_1) + (P_2^3 \times t_2) + \dots + (P_n^3 \times t_n)}{100}}$$

Where P_1 = constant load for t_1 minutes
 P_2 = constant load for t_2 minutes
 P_n = constant load for t_n minutes

2.4 Static Load Rating

In cases when the bearings are to rotate at relatively slow speeds, have slow oscillating movements, or are exposed to shock, the basic static load rating (C_{or}) must be taken into consideration.

3. Adjusted Rating Life Calculations

Bearing fatigue life can be adjusted for reliability, material and operating conditions through the following formula:

$$L_{hna} = a_1 \times a_2 \times a_3 \times L_h \text{ (hours)}$$

— a_1 , Life adjustment Factor for Reliability

L_{10} is the life based upon 90% survival of a group of bearings. When the application requires a higher reliability, the a_1 , life adjustment factor can be selected from table 18.

Table 18

Reliability %	L_n	Factor a_1
90	L_{10}	1
95	L_5	0.62
96	L_4	0.53
97	L_3	0.44
98	L_2	0.33
99	L_1	0.21

— a_2 , Life adjustment Factor for Bearing Materials

The a_2 life adjustment factor depends upon the properties and heat treatment of the bearing steel. PEER uses an $a_2 = 1$ for its high quality, vacuum degassed, SAE 52100 steel used in the rings and balls of the bearings.

— a_3 , Life adjustment Factor for Operating Conditions

The a_3 factor is a result of any number of operating factors the end user wishes to consider in the life analysis, including cleanliness of environment, temperature, lubrication and shaft alignment. These factors taken together reflect the a_3 factor.

LUBRICANT TYPES

Oil is the basic lubricant for ball bearings. Previously most lubricating oil was refined from petroleum. Today, however, synthetic oils such as diesters, silicone and fluorocarbon compounds have found acceptance because of improvements in properties. Compared to petroleum base oils, diesters in general give better low temperature properties, lower volatility, and better temperature/viscosity characteristics. Silicones and fluorocarbon compounds possess an even lower volatility and wider temperature/viscosity properties. Virtually all oils contain additives that limit chemical changes, protect the metal from corrosion, and improve physical properties (antifoam, etc.).

Grease

Grease is an oil to which a thickener has been added to prevent oil migration from the lubrication site. It is used in situations where frequent replenishment of the lubricant is undesirable or impossible. All of the oil types mentioned in the next section can be used as grease bases to which are added metallic soaps, synthetic fillers and thickeners. The operative properties of grease depend almost wholly on the base oil. Other factors being equal, the use of grease rather than oil results in higher starting and running torques and can limit the bearing to lower speeds.

OILS AND BASE FLUIDS

Petroleum Lubricants

Petroleum lubricants have excellent load carrying abilities, but are useable only at moderate temperature ranges (-25° to 250° F). Greases that use petroleum oils for bases have a high dN capability. Greases of this type would be recommended for use at moderate temperatures, light to heavy loads, and moderate to high speeds.

Super-Refined Petroleum Lubricants

While these lubricants are usable at higher temperatures than petroleum oils (-65° to 350° F), they still exhibit the same excellent load carrying capacity. This further refinement eliminates unwanted properties, leaving only the desired chemical chains. Additives are introduced to increase the oxidation resistance, etc.

Synthetic Lubricants

The diesters are probably the most common synthetic lubricants. They do not have the film strength capacity of a petroleum product, but do have a wide temperature range (-65° to 350° F) and are oxidation resistant. Synthetic hydrocarbons are finding a greater use in the miniature and instrument ball bearing industry because they have proven to be a superior general purpose lubricant.

Silicone Lubricants

Silicone products are useful over a wide temperature range (-100° to 400° F) but do not have the film strength of petroleum types and other synthetics. It has become customary in the instrument and miniature bearing industry, in recent years to derate the dynamic load rating (Cr) of a bearing to 1/3 of the value shown in this catalog if a silicone product is used. Some silicones have a very low vapor pressure (10^{-6} Torr) and can be used for bearing vacuum applications above this pressure.

Perflourinated Polyether

Oils and greases of this type have found wide use where high temperature stability, chemical inertness, or low vapor pressure (10^{-9} Torr), are required. This specialty lubricant does not have the film strength of a petroleum or diester product. However, it does have better film strength than silicone lubricants.

LUBRICATION METHODS

Grease *packing* to approximately 25% of a ball bearing's free volume is PEER's most common method of lubrication. In some instances, customers have requested that bearings be lubricated 100% full of grease. It causes shearing, heat buildup and deterioration through constant churning which can ultimately result in bearing failure.

OPERATION SPEED

When petroleum or synthetic ester oils are used, the limiting speed is dictated by the ball cage material and design or the centrifugal ball loads rather than by the lubricant.

Lubricant for Commercial and Military Specifications

Lubricants can be designated by the customer to meet a particular specification. We have included a table of widely used greases and some of their most important characteristics. All commercial oil and grease lubricants applicable to ball bearings are readily available at PEER.

LUBRICANT SELECTION

Through years of experience, PEER has simplified the potentially confusing task of selecting the proper lubricant for your ball bearing applications. Although there are hundreds of lubricants available, PEER can assist you in selecting an oil or grease appropriate for any ball bearing's operating parameters. PEER successfully uses the selection method below.

Step 1

Determine the speed of the bearing and calculate the dN value ($dN = \text{bore in mm} \times \text{RPM}$). Select the oil type that will operate within the dN value, refer to table 19.

Step 2

Determine the required minimum operating viscosity V_1 of the lubricating oil, or the base oil of the grease. V_1 is a function of the bearing's pitch diameter D_{pw} ($D_{pw} = \frac{d+D}{2}$ in mm) and its operating speed in RPM, see table 20.

Step 3

Define the temperature range of the application, taking into consideration any factors that will influence the application's temperature, such as environment, adjacent machinery, etc. Determine the minimum viscosity of the lubricating oil, or the base oil of the grease, at 40°C using table 21. The viscosity of the oil at 40°C is a function of V_1 and the maximum temperature of the bearing application.

Step 4

Once you have determined these factors, the lubricant selection has been narrowed to the type of base oil, the operating temperature range, and the minimum oil viscosity at 40°C. Next, determine whether a grease or oil is needed for the application. Then, individual lubricants should be examined to determine their suitability for the application. Refer to the grease table for individual characteristics of the various entries.

SPEED FACTOR

The maximum usable operating speed of a grease lubricant is dependent on the type of oil. The speed factor is a function of the bore of the bearing (d) in millimeters (mm) and the speed of the bearing (N) in revolutions per minute (RPM) where: $dN = d (\text{bearing bore, mm}) \times N (\text{RPM})$.

Table 19. Relationship between lubricants and dN values.

TYPE	dN
Silicone	200,000
Diester	400,000
Petroleum	600,000

Note: Spray mist oil lubricated bearings can operate in excess of these values but proper care and selection is essential.

The preceding selection process encompasses nearly all rotating ball bearing applications. It will eliminate those oils or greases which may be inappropriate. Special environmental conditions (vacuum, radiation, etc.) should be considered separately because they will determine the use of special lubricants.

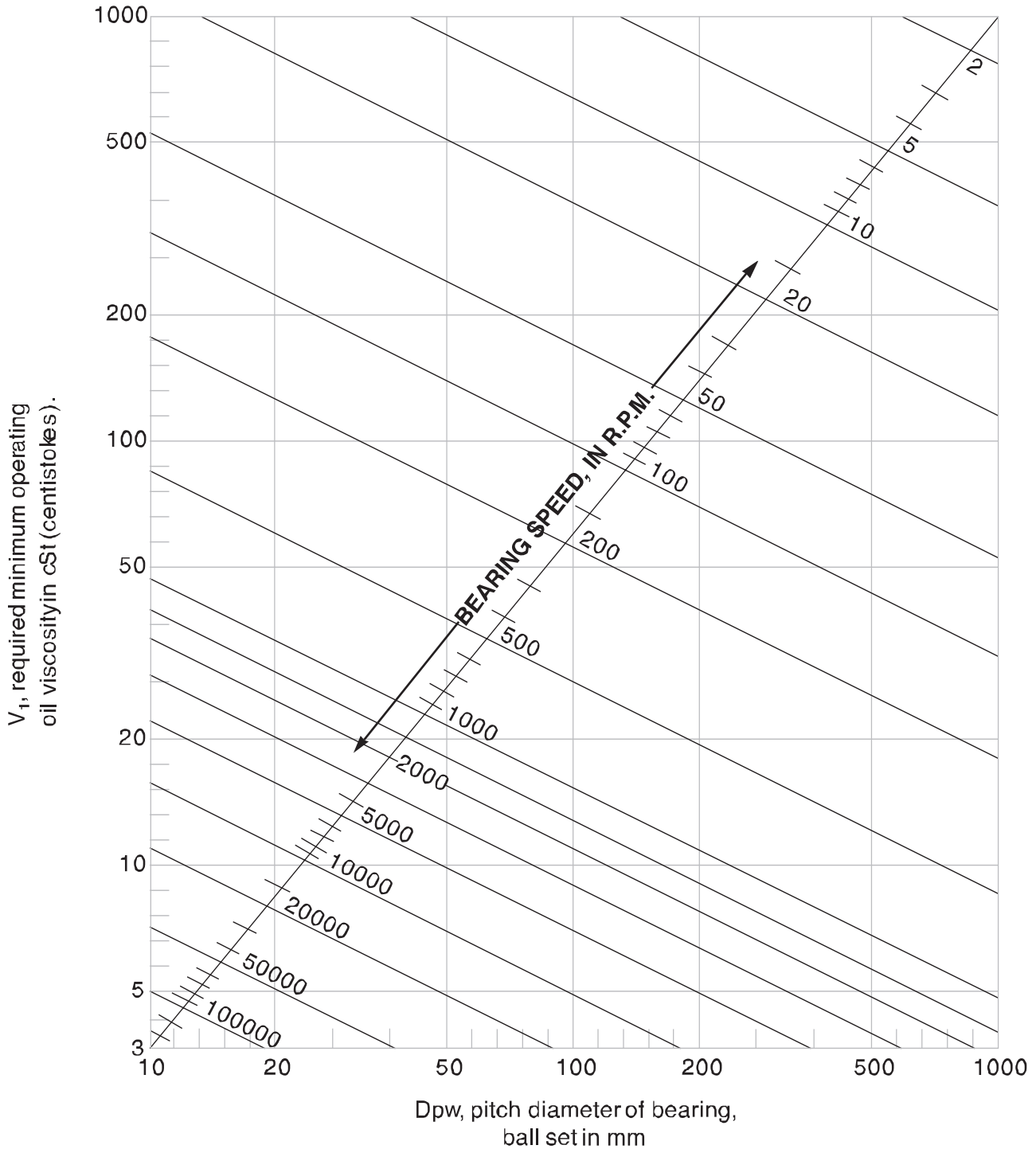

Table 20

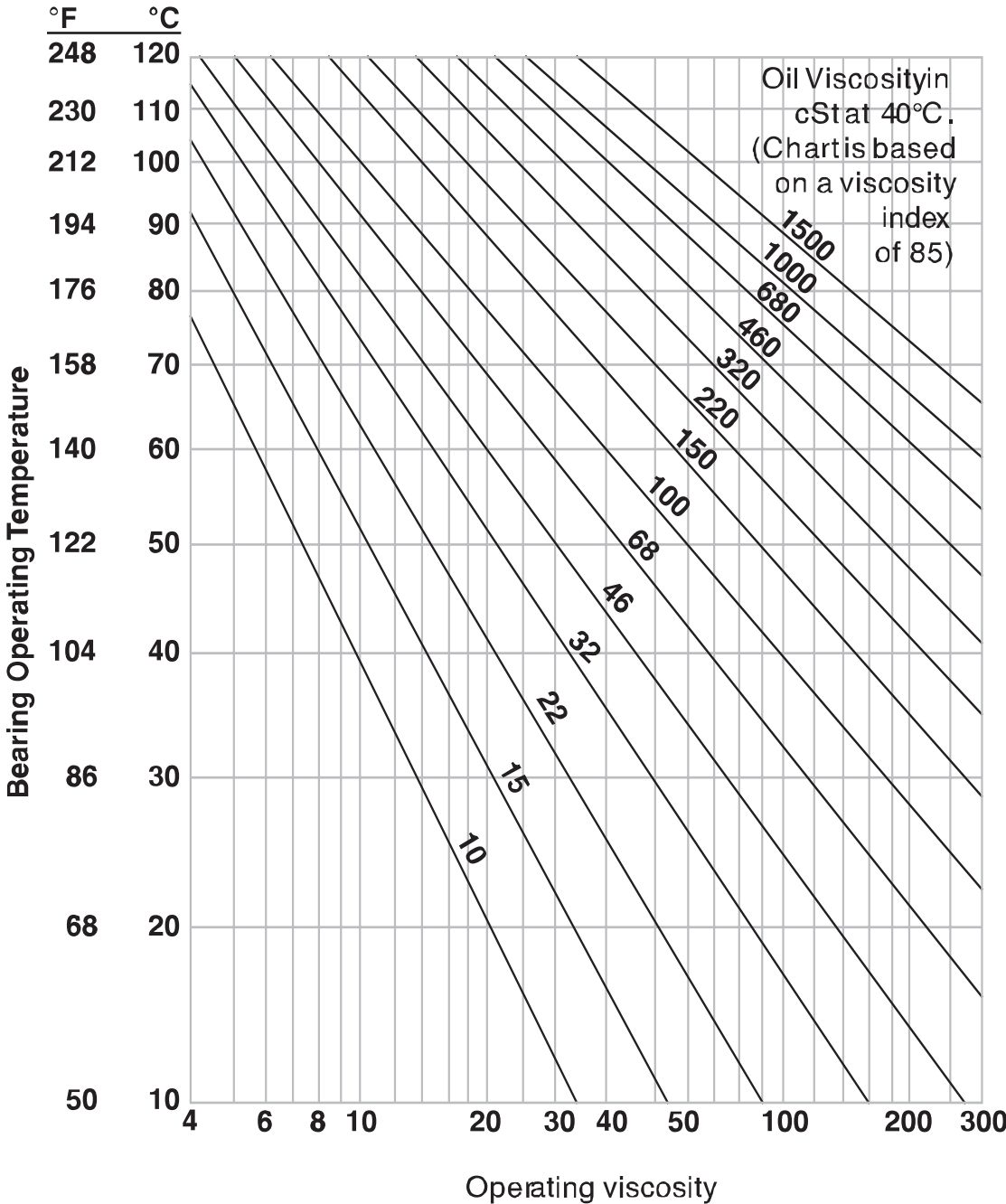

Table 21

TABLE 22 - GREASE COMPARISON

Manufacturer	Chevron	Chevron	Chevron	Chevron	Dow Corning	Dow Corning
Product Name	Black Pearl EP #2	FM #2	Ultra-Duty EP #2	SRI #2	41	44 Med.Consistency
Color	Black	Crème/Apricot or white	Red	Green	Black	white
Thickener Type	Polyurea Complex	Polyurea FDA Approved	Lithium-12 Hydroxy-stearate	Polyurea	Carbon Black	Lithium
Oil type	Mineral	Mineral	Mineral	Mineral	Silicone	Silicone
NLGI No.	2	2	2	2	2	2
Base Oil viscosity in cSt @40°C cSt @100°C	154 14	202 19	400 24	116 12	150 28	88 22
Recommended op. Temp. range	-40° / 320°F	-40° / 320°F	23° / 290°F	-20° / 350°F	0° / 550°F	-40° / 400°F
Dropping Point	473°F	550°F	374°F	470°F	+500°F	400°F
PEER Grease Code	L107	L67	L114	L19	L128	L27

Manufacturer	DuPont	Exxon	Exxon	Exxon	Kyodo Yushi	Kyodo Yushi
Product Name	Krytox 240AC	Unirex N2	Unirex N3	Beacon 325	Multemp SB-M	Multemp ET-K
Color	White	Green	Green	Light Tan	Light Brown	Light Brown
Thickener Type	Synthetic	Lithium Complex	Lithium Complex	Lithium	Diurea	Diurea
Oil type	Synthetic	Mineral	Mineral	Synthetic	Synthetic Hydrocarbon	Synthetic
NLGI No.	2	2	3	2	3	1.5
Base Oil viscosity in cSt @40°C cSt @100°C	270 26	115 12.2	115 12.2	12 3	47.6 7.9	95.1 12.8
Recommended op. Temp. range	-30° / 550°F	-40° / 250°F	-40° / 250°F	-65° / 250°F	-40° / 390°F	-40° / 390°F
Dropping Point	617°F	437°F	448°F	356°F	+500°F	450°F
PEER Grease Code	L76	L05	L131	L06	L157	L68

GREASE COMPARISON (continued)

Manufacturer	Kyodo Yushi	Mobil	Mobil	Mobil	Mobil	Nye
Product Name	Multemp SRL	Polyrex EM	Mobilgrease 28	Mobiltemp 1	Mobilith SHC100	Nyogel 670 #3
Color	Light Brown	Blue	Dark Red	Amber	Red	Clear
Thickener Type	Lithium	Polyurea	Clay	Clay	Lithium Complex	Silica
Oil type	Synthetic Ester	Mineral	Synthetic Hydrocarbon/PA.O.	Mineral	Synthetic P.A.O.	Synthetic Hydrocarbon
NLGI No.	3	2	2	1	2	3
Base Oil viscosity in cSt @40°C cSt @100°C	26.0 5.1	115 12.2	31.8 @38°F 5.9@99°C	460 32	100 14.5	194 22.8
Recommended op. Temp. range	-40° / 300°F	-40° / 350°F	-65° / 350°F	0/ 335°F	-60° / 350°F	-13° / 250°F
Dropping Point	376°F	550°F	+500°F	+500°F	500°F	None
PEER Grease Code	L21	L151	L60	L11	L150	L228

Manufacturer	Nye	Shell	Shell	Shell	Shell	Shell
Product Name	Nyogel 753SC	Aeroshell 5	Aeroshell 7	Aeroshell 17	Alvania RL2	Alvania RL3
Color	Black	Amber	Amber	Light Brown	Amber	Amber
Thickener Type	Carbon Black	Microgel	Microgel	Microgel	Lithium	Lithium
Oil type	Synthetic Ester	Mineral	Synthetic Diester	Mineral/Synthetic Polyester	Mineral	Mineral
NLGI No.	3	2	2	2	2	3
Base Oil viscosity in cSt @40°C cSt @100°C	54 9	520 32	10 3	23 6	98 9.40	98 9.40
Recommended op. Temp. range	-40° / 300°F	-10° / 350°F	-100° / 300°F	-65° / 400°F	-20° / 250°F	-20° / 250°F
Dropping Point	+500°F	+500°F	+500°F	+500°F	385°F	385°F
PEER Grease Code	L169	L40	L42	L79	L15	L16

*Many more greases available consult with your PEER Representative.

CONVERSION TABLE

Inch - Millimeter
1 inch = 25.400mm

Inches		0	1	2	3	4	5	6	7	8	9	10	11	12
Fraction	Decimal													
1/64	0.015625	0.397	25.400	50.800	76.200	101.600	127.000	152.400	177.800	203.200	228.600	254.000	279.400	304.800
1/32	0.031250	0.794	25.797	51.197	76.597	101.997	127.397	152.797	178.197	203.597	228.997	254.397	279.797	305.197
3/64	0.046875	1.191	26.194	51.594	76.994	102.394	127.794	153.194	178.594	203.994	229.394	254.794	280.194	305.594
1/16	0.062500	1.588	26.988	52.388	77.788	103.188	128.588	153.988	179.388	204.788	230.188	255.588	280.988	306.388
5/64	0.078125	1.984	27.384	52.784	78.184	103.584	128.984	154.384	179.784	205.184	230.584	255.984	281.384	306.784
3/32	0.093750	2.381	27.781	53.181	78.581	103.981	129.381	154.781	180.181	205.581	230.981	256.381	281.781	307.181
7/64	0.109375	2.778	28.178	53.578	78.978	104.378	129.778	155.178	180.578	205.978	231.378	256.778	282.178	307.578
1/8	0.125000	3.175	28.575	53.975	79.375	104.775	130.175	155.575	180.975	206.375	231.775	257.175	282.575	307.975
9/64	0.140625	3.572	28.972	54.372	79.772	105.172	130.572	155.972	181.372	206.772	232.172	257.572	282.972	308.372
5/32	0.156250	3.969	29.369	54.769	80.169	105.569	130.969	156.369	181.769	207.169	232.569	257.969	283.369	308.769
11/64	0.171875	4.366	29.766	55.166	80.566	105.966	131.366	156.766	182.166	207.566	232.966	258.366	283.766	309.166
3/16	0.187500	4.762	30.162	55.562	80.963	106.362	131.762	157.162	182.562	207.962	233.362	258.763	284.163	309.563
13/64	0.203125	5.159	30.559	55.959	81.359	106.759	132.159	157.559	182.959	208.359	233.759	259.159	284.559	309.959
7/32	0.218750	5.556	30.956	56.356	81.756	107.156	132.556	157.956	183.356	208.756	234.156	259.556	284.956	310.356
15/64	0.234375	5.953	31.353	56.753	82.153	107.553	132.953	158.353	183.753	209.153	234.553	259.953	285.353	310.753
1/4	0.250000	6.350	31.750	57.150	82.550	107.950	133.350	158.750	184.150	209.550	234.950	260.350	285.750	311.150
17/64	0.265625	6.747	32.147	57.547	82.947	108.347	133.747	159.147	184.547	209.947	235.347	260.747	286.147	311.547
9/32	0.281250	7.144	32.544	57.944	83.344	108.744	134.144	159.544	184.944	210.344	235.744	261.144	286.544	311.944
19/64	0.296875	7.541	32.941	58.341	83.741	109.141	134.541	159.941	185.341	210.741	236.141	261.541	286.941	312.341
5/16	0.312500	7.938	33.338	58.738	84.138	109.538	134.938	160.338	185.738	211.138	236.538	261.938	287.338	312.738
21/64	0.328125	8.334	33.734	59.134	84.534	109.934	135.334	160.734	186.134	211.534	236.934	262.334	287.734	313.134
11/32	0.343750	8.731	34.131	59.531	84.931	110.331	135.731	161.131	186.531	211.931	237.331	262.731	288.131	313.531
23/64	0.359375	9.128	34.528	59.928	85.328	110.728	136.128	161.528	186.928	212.328	237.728	263.128	288.528	313.928
3/8	0.375000	9.525	34.925	60.325	85.725	111.125	136.525	161.925	187.325	212.725	238.125	263.525	288.925	314.325
25/64	0.390625	9.922	35.322	60.722	86.122	111.522	136.922	162.322	187.722	213.122	238.522	263.922	289.322	314.722
13/32	0.406250	10.319	35.719	61.119	86.519	111.919	137.319	162.719	188.119	213.519	238.919	264.319	289.719	315.119
27/64	0.421875	10.716	36.116	61.516	86.916	112.316	137.716	163.116	188.516	213.916	239.316	264.716	290.116	315.516
7/16	0.437500	11.112	36.513	61.912	87.312	112.712	138.112	163.512	188.913	214.312	239.713	265.113	290.513	315.913
29/64	0.453125	11.509	36.909	62.309	87.709	113.109	138.509	163.909	189.309	214.709	240.109	265.509	290.909	316.309
15/32	0.468750	11.906	37.306	62.706	88.106	113.506	138.906	164.306	189.706	215.106	240.506	265.906	291.306	316.706
31/64	0.484375	12.303	37.703	63.103	88.503	113.903	139.303	164.703	190.103	215.503	240.903	266.303	291.703	317.103
1/2	0.500000	12.700	38.100	63.500	88.900	114.300	139.700	165.100	190.500	215.900	241.300	266.700	292.100	317.500
33/64	0.515625	13.097	38.497	63.897	89.297	114.697	140.097	165.497	190.897	216.297	241.697	267.097	292.497	317.897
17/32	0.531250	13.494	38.894	64.294	89.694	115.094	140.494	165.894	191.294	216.694	242.094	267.494	292.894	318.294
35/64	0.546875	13.891	39.291	64.691	90.091	115.491	140.891	166.291	191.691	217.091	242.491	267.891	293.291	318.691
9/16	0.562500	14.288	39.688	65.088	90.488	115.888	141.283	166.688	192.088	217.488	242.888	268.288	293.688	319.088
37/64	0.578125	14.684	40.084	65.484	90.884	116.284	141.684	167.084	192.484	217.884	243.284	268.684	294.084	319.484
19/32	0.593750	15.081	40.481	65.881	91.281	116.681	142.081	167.481	192.881	218.281	243.681	269.081	294.481	319.881
39/64	0.609375	15.478	40.878	66.278	91.678	117.078	142.478	167.878	193.278	218.678	244.078	269.478	294.878	320.278
5/8	0.625000	15.875	41.275	66.675	92.075	117.475	142.875	168.275	193.675	219.075	244.475	269.875	295.275	320.675
41/64	0.640625	16.272	41.672	67.072	92.472	117.872	143.272	168.672	194.072	219.472	244.872	270.272	295.672	321.072
21/32	0.656250	16.669	42.069	67.469	92.869	118.269	143.669	169.069	194.469	219.869	245.269	270.669	296.069	321.469
43/64	0.671875	17.066	42.466	67.866	93.266	118.666	144.066	169.466	194.866	220.266	245.666	271.066	296.466	321.866
11/16	0.687500	17.462	42.862	68.263	93.662	119.062	144.462	169.862	195.262	220.662	246.062	271.463	296.863	322.263
45/64	0.703125	17.859	43.259	68.659	94.059	119.459	144.859	170.259	195.659	221.059	246.459	271.859	297.259	322.659
23/32	0.718750	18.256	43.656	69.056	94.456	119.856	145.256	170.656	196.056	221.456	246.856	272.256	297.656	323.056
47/64	0.734375	18.653	44.053	69.453	94.853	120.253	145.653	171.053	196.453	221.853	247.253	272.653	298.053	323.453
3/4	0.750000	19.050	44.450	69.850	95.250	120.650	146.050	171.450	196.850	222.250	247.650	273.050	298.450	323.850
49/64	0.765625	19.447	44.847	70.247	95.647	121.047	146.447	171.847	197.247	222.647	248.047	273.447	298.847	324.247
25/32	0.781250	19.844	45.244	70.644	96.044	121.444	146.844	172.244	197.644	223.044	248.444	273.844	299.244	324.644
51/64	0.796875	20.241	45.641	71.041	96.441	121.841	147.241	172.641	198.041	223.441	248.841	274.241	299.641	325.041
13/16	0.812500	20.638	46.038	71.438	96.838	122.238	147.638	173.038	198.438	223.838	249.238	274.638	300.038	325.438
53/64	0.828125	21.034	46.434	71.834	97.234	122.634	148.034	173.434	198.834	224.234	249.634	275.034	300.434	325.834
27/32	0.843750	21.431	46.831	72.231	97.631	123.031	148.431	173.831	199.231	224.631	250.031	275.431	300.831	326.231
55/64	0.859375	21.828	47.228	72.628	98.028	123.428	148.828	174.228	199.628	225.028	250.428	275.828	301.228	326.628
7/8	0.875000	22.225	47.625	73.025	98.425	123.825	149.225	174.625	200.025	225.425	250.825	276.225	301.625	327.025
57/64	0.890625	22.622	48.022	73.422	98.822	124.222	149.622	175.022	200.422	225.822	251.222	276.622	302.022	327.422
29/32	0.906250	23.019	48.419	73.819	99.219	124.619	150.019	175.419	200.819	226.219	251.619	277.019	302.419	327.819
59/64	0.921875	23.416	48.816	74.216	99.616	125.016	150.416	175.816	201.216	226.616	252.016	277.416	302.816	328.216
15/16	0.937500	23.812	49.212	74.612	100.012	125.413	150.812	176.212	201.612	227.012	252.412	277.813	303.213	328.613
61/64	0.953125	24.209	49.609	75.009	100.409	125.809	151.209	176.609	202.009	227.409	252.809	278.209	303.609	329.009
31/32	0.968750	24.606	50.006	75.406	100.806	126.206	151.606	177.006	202.406	227.806	253.206	278.606	304.006	329.406
63/64	0.984375	25.003	50.403	75.803	101.203	126.603	152.003	177.403	202.803	228.203	253.603	279.003	304.403	329.803

Metric Conversion Table



Fraction	Inch	mm	Fraction	Inch	mm	Fraction	Inch	mm
1/64	0.0156	0.3969		0.2883	7.3228	11/16	0.6875	17.4625
	0.0250	0.6350	19/64	0.2969	7.5406	45/64	0.7031	17.8594
1/32	0.0312	0.7937	5/16	0.3125	7.9375		0.7087	18.0000
	0.0394	1.0000		0.3150	8.0000	23/32	0.7187	18.2562
	0.0400	1.0160	21/64	0.3281	8.3344	47/64	0.7344	18.6532
3/64	0.0469	1.1906	11/32	0.3437	8.7312		0.7435	18.8849
	0.0472	1.2000		0.3543	9.0000		0.7480	19.0000
	0.0550	1.3970	23/64	0.3594	9.1281	3/4	0.7500	19.0500
	0.0591	1.5000	3/8	0.3750	9.5250	49/64	0.7656	19.4469
1/16	0.0625	1.5875	25/64	0.3906	9.9213		0.7717	19.6012
	0.0709	1.8000		0.3937	10.0000	25/32	0.7812	19.8433
5/64	0.0781	1.9844	13/32	0.4062	10.3187		0.7874	20.0000
	0.0787	2.0000		0.4100	10.4140	51/64	0.7969	20.2402
	0.0906	2.3012	27/64	0.4219	10.7156	13/16	0.8125	20.6375
3/32	0.0937	2.3812		0.4250	10.7950		0.8268	21.0000
	0.0984	2.5000		0.4331	11.0000	53/64	0.8281	21.0344
	0.1000	2.5400	7/16	0.4375	11.1125	27/32	0.8437	21.4312
	0.1024	2.6000	29/64	0.4531	11.5094	55/64	0.8594	21.8281
7/64	0.1094	2.7781		0.4600	11.6840		0.8661	22.0000
	0.1100	2.7940	15/32	0.4687	11.9062	7/8	0.8750	22.2250
	0.1102	2.8000		0.4724	12.0000	57/64	0.8906	22.6219
	0.1181	3.0000	31/64	0.4844	12.3031		0.9055	23.0000
1/8	0.1250	3.1750	1/2	0.5000	12.7000	29/32	0.9062	23.0187
	0.1256	3.1902		0.5118	13.0000	59/64	0.9219	23.4156
	0.1378	3.5000	33/64	0.5156	13.0968	15/16	0.9375	23.8125
9/64	0.1406	3.5719	17/32	0.5312	13.4937		0.9449	24.0000
5/32	0.1562	3.9687	35/64	0.5469	13.8906	61/64	0.9531	24.2094
	0.1575	4.0000		0.5512	14.0000	31/32	0.9687	24.6062
11/64	0.1719	4.3656	9/16	0.5625	14.2875		0.9843	25.0000
3/16	0.1875	4.7625	37/64	0.5781	14.6844	63/64	0.9844	25.0031
	0.1892	4.8057		0.5906	15.0000		1.0000	25.4000
	0.1969	5.0000	19/32	0.5937	15.0812		1.0236	26.0000
13/64	0.2031	5.1594	39/64	0.6094	15.4781		1.0415	26.4541
	0.2165	5.4991	5/8	0.6250	15.8750		1.0480	26.6192
7/32	0.2187	5.5562		0.6299	16.0000	1-1/16	1.0625	26.9875
15/64	0.2344	5.9531	41/64	0.6406	16.2719		1.0630	27.0000
	0.2362	6.0000		0.6500	16.5100		1.1025	28.0000
1/4	0.2500	6.3500	21/32	0.6562	16.6687	1-1/8	1.1250	28.5750
17/64	0.2656	6.7469		0.6620	16.8148		1.1417	29.0000
	0.2756	7.0000		0.6693	17.0000		1.1812	30.0000
9/32	0.2812	7.1437	43/64	0.6719	17.0656	1-3/16	1.1875	30.1625
						1-1/4	1.2500	31.7500
						1-1/2	1.5000	38.1000



Temperature Conversion Table

°C	°C/°F	°F	°C	°C/°F	°F	°C	°C/°F	°F	°C	°C/°F	°F
-79	-110	-166	37.7	100	212	204	400	752	371	700	1292
-73	-100	-148	43	110	230	210	410	770	376	710	1310
-68	-90	-130	49	120	248	215	420	788	382	720	1328
-62	-80	-112	54	130	266	221	430	806	387	730	1346
-57	-70	-94	60	140	284	226	440	824	393	740	1364
-51	-60	-76	65	150	302	232	450	842	565	1050	1922
-46	-50	-58	71	160	320	238	460	860	571	1060	1940
-40	-40	-40	76	170	338	243	470	878	576	1070	1958
-34	-30	-22	83	180	356	249	480	896	582	1080	1976
-29	-20	-4	88	190	374	254	490	914	587	1090	1994
-23	-10	14	93	200	392	260	500	932	593	1100	2012
-17.7	0	32	99	210	410	265	510	950	598	1110	2030
-17.2	1	33.8	104	220	428	271	520	968	604	1120	2048
-16.6	2	35.6	110	230	446	276	530	986	609	1130	2066
-16.1	3	37.4	115	240	464	282	540	1004	615	1140	2084
-15.5	4	39.2	121	250	482	288	550	1022	620	1150	2102
-15.0	5	41.0	127	260	500	293	560	1040	626	1160	2120
-14.4	6	42.8	132	270	518	299	570	1058	631	1170	2138
-13.9	7	44.6	138	280	536	304	580	1076	637	1180	2156
-13.3	8	46.4	143	290	554	310	590	1094	642	1190	2174
-12.7	9	48.2	149	300	572	315	600	1112	648	1200	2192
-12.2	10	50.0	154	310	590	321	610	1130	653	1210	2210
-6.6	20	68.0	160	320	608	326	620	1148	659	1220	2228
-1.1	30	86.0	165	330	626	332	630	1166	664	1230	2246
4.4	40	104.0	171	340	644	338	640	1184	670	1240	2264
9.9	50	122.0	177	350	662	343	650	1202	675	1250	2282
15.6	60	140.0	182	360	680	349	660	1220	681	1260	2300
21.0	70	158.0	188	370	698	354	670	1238	686	1270	2318
26.8	80	176.0	193	380	716	360	680	1256	692	1280	2336
32.1	90	194.0	199	390	734	365	690	1274	697	1290	2354

Metric Conversions



MULTIPLY	BY	TO OBTAIN
Celsius Temperature (t _C)	$9/5(t_C)+32=t_F$	Fahrenheit Temperature (t _F)
Centimeter (cm)	.3937	Inch (in)
Centimeter (cm)	10	Millimeter (mm)
Dyne	.00001	Newton (N)
Dyne-Centimeter	.0000001	Newton-meter (N-m)
Fahrenheit Temperature (t _F)	$5/9(t_F)-32=t_C$	Celsius Temperature (t _C)
Foot (ft)	30.48	Centimeter (cm)
Foot (ft)	.3048	Meter (m)
Gallon, U.S. liquid (gal)	3.785412	Liter (l)
Gram (g)	.03527397	Ounce (oz)
Horsepower (hp)	.7456999	Kilowatt (kW)
Horsepower (hp)	745.6999	Watt (W)
Inch (in)	2.540	Centimeter (cm)
Inch (in)	.0254	Meter (m)
Inch (in)	25.4	Millimeter (mm)
Joule (J)	.0009478170	British thermal unit (Btu)
Kilogram (kg)	2.20	Pound (lb)
Kilogram-force (kgf)	9.80665	Newton (N)
Kilometer (km)	.6213712	Mile
Liter (l)	.03531466	Cubic foot (ft ³)
Liter (l)	.001	Cubic meter (m ³)
Liter (l)	.2641720	Gallon, U.S. liquid
Meter (m)	39.37008	Inch (in)
Meter (m)	3.280840	Foot (ft)
Meter (m)	1.0936	Yard (yd)
Micron (μm)	1000	Millimeter (mm)
Micron (μm)	10 ⁶	Meter (m)
Mile	1.609344	Kilometer (km)
Millimeter (mm)	.03937008	Inch (in)
Millimeter (mm)	.003280840	Foot (ft)
Newton (N)	.2248	Pound-force (lbf)
Ounce (oz)	28.3495	Gram (g)
Pound (lb)	.453592	Kilogram (kg)
Pound-force (lbf)	4.448	Newton (N)
Yard (yd)	.9144	Meter (m)



USA

PEER Bearing Headquarters
2200 Norman Drive
Waukegan, IL 60085
USA
Ph: 1 847 578 1000
info@peerbearing.com

China

PEER China — SPZ
Rm 2306 Fortune Times Building #1438 North
Shaanxi Road Putuo District, Shanghai,
China
Ph: +86 21 61484816
sales@peerchina.com

Italy

PEER Bearing S.R.L.
Via Paolo Nanni Costa, 12/3 A
40133 Bologna
Italy
Europe.info@peerbearing.com

Germany

PEER Bearing GmbH
Mainzer Landstraße 47
60329 Frankfurt am Main
Germany
Ph: +49 (0) 69 95 92 54 90
Europe.info@peerbearing.com

Brazil

Alameda Mamoré, 535-cj. 408/410
Alphaville—Barueri—SP Brazil
CEP 06454-040
Ph: +55 11 4166 5650
LAM.info@peerbearing.com

United Kingdom

Unit 6, Chelworth Park
Chelworth Road
Cricklade, Wilshire
SN6 6HE, England
Ph: +44 (0) 1793 759459
Europe.info@peerbearing.com



PEER's World-Wide Manufacturing Facilities



PEER Ball Bearing Factory, Xinchang, Zhejiang, China



PEER Tapered Bearing Factory, Changshan, Zhejiang, China

Distributed by:

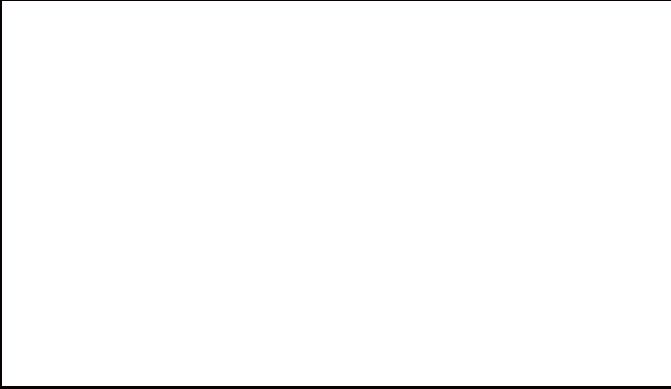

USA Headquarters
2200 Norman Drive
Waukegan, IL 60085
Tel: 847-578-1000
Fax: 847-578-1200
e-mail: info@peerbearing.com
www.peerbearing.com

Proud Member of:



Radial Ball Bearings

