

STANDARD OPERATING PROCEDURE
MANUAL
FOR
DAMOS MONITORING ACTIVITIES
VOLUME II

CONTRIBUTION #48

August 1, 1985

Contract #DACW33-85-D-0008

SAIC Report #SAIC-85/7516&C48

Submitted to:

New England Division
U.S. Army Corps of Engineers
424 Trapelo Road
Waltham, MA 02254

Submitted by:

Science Applications International Corporation
Ocean Science & Technology Division
Admiral's Gate, 221 Third Street
Newport, RI 02840
(401) 847-4210

SAICTM

TABLE OF CONTENTS

	<u>Page</u>
II. STANDARD OPERATING PROCEDURES FOR SEDIMENT SAMPLING	
1.0	OBJECTIVES OF SEDIMENT SAMPLING II-1
2.0	BENTHIC SAMPLING II-1
2.1	Sampling and Analysis II-5
2.2	Site Specific Considerations II-5
2.3	Presentation of Results II-12
3.0	SEDIMENT CHEMISTRY II-12
III. STANDARD OPERATING PROCEDURE FOR DAMOS MUSSEL WATCH	
1.0	OBJECTIVES OF THE MUSSEL WATCH PROGRAM III-1
2.0	FIELD OBSERVATION PROCEDURES III-1
2.1	Monitoring Platforms III-2
2.2	Deployment and Sampling Procedures III-4
3.0	ANALYSIS PROCEDURES III-5
3.1	Trace Metal Analysis III-5
3.2	Analysis of Polychlorinated Biphenyls III-6
3.3	Histopathological Studies III-7
3.4	Statistical Analysis of the Data III-7

TABLE OF CONTENTS (CONT.)

	<u>Page</u>
4.0 PRESENTATION OF RESULTS	III-8
 IV. STANDARD OPERATING PROCEDURES FOR SPECIAL EQUIPMENT AND OBSERVATIONS 	
1.0 IN-SITU SEDIMENT-PROFILE IMAGING, DATA ANALYSIS AND MAPPING	IV-1
1.1 Objectives	IV-1
1.2 Instrument Deployment and Operational Requirements	IV-1
1.3 Image Analysis	IV-2
1.4 Mapping	IV-20
2.0 SEDIMENT TRANSPORT INVESTIGATIONS	IV-26
2.1 Objectives	IV-26
2.2 Instrumentation Characteristics	IV-26
2.3 Field Procedures	IV-34
2.4 Data Processing	IV-35
3.0 CURRENT MEASUREMENTS	IV-36
3.1 General Oceanics Current Meter	IV-36
3.2 Neil Brown Direct Reading Current Meter	IV-51
4.0 SCUBA AND DEEP WATER IN-SITU ASSESSMENT OF CONDITIONS AT DREDGED MATERIAL DISPOSAL SITES	IV-57

TABLE OF CONTENTS (CONT.)

	<u>Page</u>
4.1 Observations of Benthic Conditions	IV-57
4.2 Physical and Biological Benthic Conditions	IV-60
4.3 Analysis of Still and Video Imagery	IV-63
4.4 Data Products	IV-64
V. STANDARD OPERATING PROCEDURES FOR THE DAMOS PROJECT DATA BASE	
1.0 INTRODUCTION	V-1
2.0 THE DAMOS PROJECT DATA BASE	V-1
2.1 Data Base Design	V-1
2.2 Implementing the DAMOS PDB	V-7
2.3 Transfer of Data to NED	V-10
2.4 Retrieval of Data	V-10
VI. REFERENCES	VI-1

LIST OF FIGURES

		<u>Page</u>
III-2-1	Schematic diagram of the PVC sampling platform.	III-3
IV-1-1	The apparent distribution and thickness of dredged material, averaged by station, at the FVP site in December 1984.	IV-21
IV-1-2	Mapped average RPD values at each station.	IV-23
IV-1-3	Mapped distribution of benthic indices for all replicates in the December survey.	IV-24
IV-1-4	Benthic index frequency distributions for the edge and ambient, on mound, and CLIS-REF stations.	IV-25
IV-2-1	Current speed.	IV-37
IV-2-2	Water temperature - near bottom.	IV-38
IV-2-3	Salinity - near bottom.	IV-39
IV-2-4	Suspended material concentrations.	IV-40
IV-2-5	Surface wave energy field.	IV-41
IV-3-1	Niskin winged current meter (NWCM), model 6011, tilting downstream and independent of mooring inclination.	IV-47
IV-3-2	Stick plot of 40-hour low-pass filtered current meter data from the mid-Atlantic Bight.	IV-52
IV-3-3	Temperature stack and current meter stick plots.	IV-53
IV-3-4	Temperature stack plot of data from the Blake Plateau at 30°N.	IV-54

LIST OF FIGURES (CONT.)

		<u>Page</u>
IV-3-5	U and V component spectra, coherence squared, and phase differences for a current meter record.	IV-55
IV-3-6	Sample plot of results from Neil Brown DRCM.	IV-58

LIST OF TABLES

		<u>Page</u>
II-1-1	Sediment Sampling Stations at DAMOS Disposal Sites	II-2
II-2-1	Taxonomic keys for Benthic Invertebrates	II-6
II-2-2	Benthic Organism Count - CADS	II-13
II-2-3	Dominant Species - CADS	II-16
II-2-4	Number of Individuals and Species - CADS	II-17
II-3-1	Results of Chemical Analysis	II-18
II-3-2	Results of Physical Testing	II-19
II-3-3	Summary of Chemical Results	II-20
III-4-1	Summary of wet/dry ratios, shell length and tissue metal concentrations in <u>Mytilus edulis</u> deployed at four stations in Eastern and Western Long Island Sound from June to September 1984	III-9
III-4-2	Summary of Two-way ANOVA for CD, Cu, Zn, Ni, V and W/D	III-10
III-4-3	Elemental Enrichment Factors in Surficial Sediments Obtained from Western Long Island Sound Disposal Sites	III-11
III-4-4	Frequencies of <u>Pinnotheres Maculatus</u> Infection in <u>Mytilus edulis</u> Maintained at R1r, WLISrN and WLISc from June through September 1984	III-12
IV-1-1	REMOTS Sampling Stations	IV-3
IV-1-2	REMOTS at CADS	IV-5
IV-1-3	REMOTS Stations at FADS	IV-7
IV-2-1	Model 651-8 Detailed Specifications	IV-32

LIST OF TABLES (CONT.)

		<u>Page</u>
IV-3-1	Niskin Winged Current Meter Model 6011 Specifications	IV-45
IV-3-2	Bivariate Frequency Distribution for Current Speed and Direction.	IV-55
IV-3-3	Variables Measured by Neil Brown DRCM	IV-57
IV-4-1	DAMOS Diver Monitoring Log	IV-61
V-2-1	Structure of the DAMOS Inventory File	V-3
V-2-2	Structure of the DAMOS Data Files	V-4
V-2-3	Structure of the DAMOS Parameter Files	V-8

II. STANDARD OPERATING PROCEDURES FOR SEDIMENT SAMPLING

1.0 OBJECTIVES OF SEDIMENT SAMPLING

On DAMOS monitoring cruises, sediment samples are collected regularly with a Smith MacIntyre grab sampler. This instrument samples approximately 0.1 m² of the bottom sediment to a depth of about 25 cm. Because the design of the Smith MacIntyre grab includes springs and trigger pads, the frequency of successful grabs is greater than 80%. Only rocks or shells caught in the jaws will prevent the sediment sample from reaching the surface.

The sediment obtained is analyzed for two completely separate types of information. Bulk sediment chemistry is performed on certain samples while other samples are sieved for benthic organism identification. By regularly monitoring the chemical composition and the species abundance and diversity of the bottom substrate, changes caused by dredged material disposal may be detected. Visual description of the sediment is also useful in detecting the extent of dredged material. Table II-1-1 lists the stations sampled at all DAMOS disposal sites throughout New England. A station naming convention has been employed in DAMOS to distinguish the sediment samples by disposal site and distance from the center of survey (See Section I). Station FVP-1000E would indicate that sediment was collected 1000 meters East from the center of the FVP survey. All directions are relative to true bearings.

2.0 BENTHIC SAMPLING

Since the inception of the DAMOS program, samples have been taken to identify benthic communities in the vicinity of disposal sites to determine whether changes had occurred as a result of disposal, and to describe the recolonization of dredged material. A variety of sediment and benthic community types are found at the DAMOS sites. The presence of dredged material introduces more variability.

For a number of years, DAMOS samples have been sieved to 1 mm to be consistent with earlier NOAA surveys and to reduce sorting time. Analysis of samples from Long Island Sound indicate that information on key species is lost using a sieve this coarse. Since most current survey work carried out by EPA, NOAA and MMS utilizes sieves 0.5 mm or finer, there is pressure to use these finer sieves in DAMOS projects. Two recent surveys (CADS, FADS) were carried out using both 1 and 0.5 mm sieves. In some study areas where there are very large numbers of small individuals, changes in sample area and numbers of samples may be required to avoid unnecessary expenditure when a 0.5 mm sieve is used.

TABLE II-1-1

SEDIMENT SAMPLING STATIONS AT DAMOS DISPOSAL SITES

<u>ROCKLAND</u>	<u>PORTLAND</u>	<u>CADS</u>	<u>IOS</u>
----	200N	100N	400N
200N	250N	100S	400S
400N	200S	100E	400E
----	300S	50E	400W
200S	100W	CTR	CTR
400S	400W	REF	
200W	200E		
400W	300E		
200E	400E		
400E	CTR		
2000E	REF		
200NE			
400NE			
200SE			
400SE			
200NW			
400NW			
200SW			
400SE			
CTR			

<u>FADS</u>	<u>FADS-S</u>	<u>WELLFLEET</u>	<u>BRENTON REEF</u>
250N	250N	100N	300SW
500N	500N	250N	1000SW
250S	250S	400N	CTR
500S	500S	300S	REF
250E	250E	400S	
500E	500E	500S	
250W	250W	100E	
500W	500W	200E	
CTR	CTR	275E	
REF	REF	400E	
		1000E	
		300W	
		400W	
		CTR	

Table II-1-1 (Cont.)

<u>NLON</u>	<u>NL-3</u>	<u>NL-4</u>	<u>FVP</u>
300E	IIIN	150W	200N
600E	III-CTR	450W	400N
1000E	III-S	500E	200S
300W	III-350W	CTR	400S
600W			200E
400S			400E
600S			600E
CTR			1000E
REF			200W
			400W
			CTR
<u>NH-74</u>	<u>NH-83</u>	<u>STNH-N</u>	<u>STNH-S</u>
400E	375E	100N	100N
500E	450E	200N	250N
CTR	CTR	100S	250S
		250S	100E
		200E	300E
		400E	400E
		150W	150W
		300W	250W
		CTR	400W
			CTR

Table II-1-1 (Cont.)

<u>CS-1</u>	<u>CS-2</u>	<u>NORWALK</u>	<u>MQR</u>
200E	200E	100N	100N
300E	350E	300N	200N
CTR	CTR	150S	300N
		450S	400N
		150E	100S
		300E	150S
		150W	200S
		400W	300S
		CTR	350S
			400S
			100E
			200E
			300E
			400E
			200W
			250W
			300W
			400W
			500W
			CTR

<u>CLIS</u>	<u>WLIS-A</u>	<u>WLIS-B</u>
REF	100N	50N
	200N	200N
	400N	400N
	100S	50S
	200S	200S
	400S	400S
	100E	50E
	200E	100E
	400E	150E
	100W	200E
	200W	400E
	400W	50W
	CTR	200W
	REF	400W
		CTR
		REF

Because of the variability between study areas and the different goals of surveys in each area, it has been necessary to use different sample handling techniques. The following is a description of present DAMOS benthic techniques and possibilities for future modification.

2.1 Sampling and Analysis

Replicate grab samples are taken with a 0.1 m^2 Smith-MacIntyre grab sampler and washed with salt water on a 1 or 0.5 mm sieve. To avoid damaging organisms, no attempt is made to break up and wash away all mud balls, worm tubes and clay lumps. The animals and residue are preserved in 10 percent formalin with rose-bengal dye.

In the laboratory, washing is completed and samples are split into various fractions. Recent samples from Cape Arundel, Maine and the Foul Area, MA, were split into 1 and 0.5 mm fractions for comparison with existing DAMOS and EPA samples. Sieving is carried out in a container of water so that particles can be suspended to increase their opportunity to pass through the sieve.

Sieved material may contain pebbles, shells, polychaete tubes or strands of polychaetes and oligochaetes adhering to anemone tubes. Therefore, the benthic infauna must be picked by hand to separate the living species from the inorganic material. The number of individuals increases with decreased body size in many cases.

Sorting is more efficient in a relatively uniform material. When a sample must be divided to reduce the number of individuals, homogeneity is required to avoid fractionation during the splitting procedure. Homogeneous fractions can be produced by sieving and by suspension and decanting of light material. Suspendable fine material is then split with a rotating plankton splitter. Heavy fractions can be mixed moist and measured by volume in water. Identification of animals to species level is conducted using taxonomic keys listed in Table II-2-1. While identifications are being made, a reference collection of voucher specimens is preserved to insure consistency between samples and personnel.

2.2 Site Specific Considerations

Central and Western Long Island Sound -- The natural sediment in these areas is silt-clay which passes easily through a 0.5 mm sieve. Abundant dead shells of Mulinia lateralis and fragments of cerianthid anemone tubes slow processing of this material. It has been found helpful to separate cerianthid "slime," organic detritus, and polychaetes by decantation. Heavy material, (> 1 mm) is sorted from a glass tray with strong lighting and a white background. All other materials are sorted under a microscope.

Table II-2-1

TAXANOMIC KEYS FOR BENTHIC INVERTEBRATES

Some classic literature for invertebrate taxonomy of organisms found along the New England coast

General References :

Gosner, K. L. 1971. Guide to Identification of Marine and Estuarine Invertebrates. Wiley-Interscience. N.Y. 693 p.

Gosner, K. L. 1978. A Field Guide to the Atlantic Seashore. Houghton Mifflin Co., Boston. 329 pp.

Meinkoth, N. A. 1981. The Audubon Society Field Guide to North American Seashore Creatures. Alfred Knopf, Inc. New York. 798 pp.

Smith, R. 1964. Keys to the Invertebrates of the Woods Hole Region. Marine Biology Systematics Program, Woods Hole Mass. Contribution #11. 208 pp.

Porifera references :

Hartman, W. D. 1958. Natural history of the marine sponges of southern New England. Bull. Peabody Mus. Nat. Hist. #12 155 pp.

Kingsley, J. S. 1901. Preliminary catalogue of the marine invertebrata of Casco Bay, Maine. Proc. Portland Soc. Nat. Hist. 2:159-183.

Lambe, L. M. 1896. Sponges from the Atlantic coast of Canada. Trans. Roy. Soc. Can. 2:181-211.

Miner, R. W. 1950. Field Book of Seashore Life. Van Rees Press, N.Y. 888 pp.

Procter, W. 1933. Biological survey of the Mt. Desert region. Part 5, Marine fauna. Wistar Institute Press.

Hydrozoa :

Fraser, C. M. 1944. Hydroids of the Atlantic coast of North America. Univ. Toronto Press. 451 pp

Anthozoa :

Hand, C. 1964. Phylum Cnidaria, Class Anthozoa. IN: Keys to the Invertebrates of the Woods Hole Region, R. Smith, Ed. Contr.#2, Systematic Ecology Program, Mar. Biol. Lab. Woods Hole, Ma. 25-28.

Hargitt, C. W. 1914. The anthozoa of the Woods hole Region. Bull. U.S. Bur. Fish. 32: 223-254.

Kingsley, J. S. 1901. Preliminary catalogue of the marine invertebrata of Casco Bay, Maine. Proc. Portland Soc. Nat. Hist. 2:159-183.

TABLE II-2-1 (Cont.)

Rhynchozoela :

Coe, W. R. 1943. Biology of the nemerteans of the Atlantic coast of North America. Trans. Conn. Acad. Arts Sci. 35: 129-326.

Ectoprocta :

Osburn, R. C. 1912. The bryozoa of the Woods Hole region. Bull. U.S. Bur. Fish. 30: 205-266.

Osburn, R. C. 1933. Bryozoa of the Mt. Desert region. Biological survey of the Mt. Desert region. Part 5. Marine fauna. Wistar Institute Press.

Mollusca :

Abbott, R. T. 1954. American Seashells. Van Nostrand, N.Y. 541 pp

Abbott, R. T. 1968. Seashells of North America. Golden Press, New York. 280 pp.

Abbott, R. T. 1974. American Seashells. Von Nostrand, New York. 663 pp.

Bousfield, E. L. 1960. Canadian Atlantic Sea Shells. Nat. Mus. Canada. 72 pp.

Emerson, W. K. and M. K. Jacobson. 1976. The American Museum of Natural History Guide to Shells. Alfred Knopf, Inc. New York. 482 pp

Gould, A. A. and W. G. Binney. 1870. Report on the Invertebrata of Massachusetts. University Press, Cambridge, Ma. 524 pp.

Johnson, C. W. 1934. List of the marine mollusca of the Atlantic coast from Labrador to Texas. Proc. Boston Soc. Nat. Hist. 40:1-203.

Loosanoff, V. L. and H. C. Davis. 1963. Rearing of the bivalve molluska. IN: Advances in Marine Biology. Academic Press, N.Y. 1-136p

Miner, R. W. 1950. Field Book of Seashore Life. Van Rees Press N.Y. 888 pp.

Morris, P. A. 1975. A Field Guide to Shells. Third Ed. Houghton Mifflin Co., Boston. 330 pp.

Procter, W. 1933. Biological survey of the Mt. Desert region. Part 5. Marine Fauna. Wistar Institute Press.

Sumner, F. B., R. C. Osburn, and L. J. Cole. 1913. A biological survey of the waters of Woods Hole and vicinity. Bull. U.S. Bur. Fish. 31:860 pp.

Thorson, D. 1946. Reproduction and larval development of Danish marine bottom invertebrates, with special reference to the planktonic larvae in the Sound (Oresund). Medd. fra Komm. for Danmarks Fiskeri og Havunders., Serie Plankton, Bd. 4:1-523.

Wilbur, K. and C. M. Yonge. 1964. Physiology of Mollusca., Vol. 1 and 2.

Table II-2-1 (Cont.)

Academic Press, N.Y.

Annelida :

Hartmann, O. 1944. New England Annelida. Part 2. Am. Mus. Nat. Hist. Bull. 82:327-344.

Hartmann, O. 1965. Deep water polychaetus annelids off New England to Bermuda and other North Atlantic areas. Allan Hancock Foundation Publ. Occ. Papers 28:1-378.

Hartmann, O. and K. Fauchald. 1971. Deepwater polychaetous annelids off New England to Bermuda. Part 2. Allan Hancock monogr. in Mar. Biol. 6:1-327.

Pettibone, M. H. 1963. Marine Polychaete Worms of the New England Region. 1. Aphroditidae through Trochochaetidae. U.S. Nat. Mus. Bull. 227: 356 pp.

Procter, W. 1933. Biological survey of the Mt. Desert region. Part 5, Marine Fauna. Wistar Institute Press.

Rasmussen, E. 1973. Systematics and ecology of the Isefjord marine fauna (Denmark). *Ophelia* 11:1-507

Thorson, D. 1946. Reproduction and larval development of Danish marine bottom invertebrates with special reference to the planktonic larvae in the Sound (Oresund). Medd. fra Komm. for Denmark's Fiskeri og Havunders., Serie Plankton, Bd. 4:1-523.

Webster, H. E. 1880. The annelida Chaetopoda of New Jersey. Rep. ew York State Mus. 32:101-128.

Webster, H. E. and J. E. Benedict. 1884. Annelida Chaetopoda from Provincetown and Wellfleet, Massachusetts. Rep. Comm. Fisheries (1881): 699-747.

Webster, H. E. and J. E. Benedict. 1887. Annelida Chaetopoda from Eastport, Maine. Rep. U.S. Fish. Comm. (1885):707-755.

Arthropoda :

Waterman, T. H. 1960. Physiology of the Crustacea. Vols. 1 and 2. Academic Press., N.Y.

Cirrepedia :

Pilsbry, H. A. 1916. The sessile barnacles (Cirrepedia) contained in the collections of the United States Nation Museum. U.S. Nat. Mus. Bull. 93:366 pp

Zullo, V. A. 1963. A preliminary report on systematics and distribution of barnacles (Cirrepedia) of the Cape Cod region. Mar. Biol. Lab. Woods Hole, Ma. 1-33

TABLE II-2- 1 (Cont.)

Tanaidacea and Isopoda :

Kunkel, B. W. 1918. The Arthrostraca of Connecticut. State Geological and Natural History Survey Bull. 26: 261 pp. Hartford.

Richardson, H. 1909. A monograph of the isopods of North America. Bull. U.S. Nat. Mus. 54:1-727.

Amphipoda :

Bousfield, E. L. 1973. Shallow water gammariean Amphipoda of New England. Cornell Univ. Press. 313 pp.

Holmes, S. J. 1905. The Amphipoda of southern New England. Bull. U.S. Fish. Comm. 24:457-529.

Kunkel, B. W. 1918. The Arthrostraca of Connecticut. State Geological and Natural History Survey Bull. 26:261 pp. Hartford.

Mysidacea :

Tattersall, W. 1951. A review of the Mysidaceae of the United States National Museum. Bull. U.S. National Museum 201: 1-292.

Wigley, R. L. 1964. Part 1, Order Mysidacea. IN: R.I. Smith, Keys to the Invertebrates of the Woods Hole Region. Mar. Biol. Lab., Woods Hole, Ma. 93-145.

Decapoda :

Rathbun, M. J. 1905. Fauna of New England. 5. Crustacea. Occ. Papers Boston Soc. Nat. Hist. 7:1-117.

Rathbun, M. J. 1929. Decapoda. IN: Canadian Atlantic Fauna 10 m. Biol. Bd. Canada, St. Andrews. 1-38

Williams, A. B. 1965. Marine decapod crustaceans of the Carolinas. U.S. Fish. Wildl. Ser. Fish. Bull. 65:298 pp.

Echinodermata :

Clark, H. L. 1904. The echinoderms of the Woods Hole region. Bull. U.S. Fish. Comm. (1902) 22:545-576.

Coe, W. R. 1912. Echinoderms of Connecticut. State Geological and Natural History Survey. Bull. 19:1-152.

Deichmann, E. 1930. The helethurians of the western part of the Atlantic Ocean. Bull. Mus. Comp. Zool. Harvard. 71:43-226.

Verrill, A. E. 1895. Distribution of the echinoderms of northeastern America. A. J. Sci. Ser. 3, 49:127-141, 199-212.

TABLE II-2- 1 (Cont.)

Tanaidacea and Isopoda :

Kunkel, B. W. 1918. The Arthrostraca of Connecticut. State Geological and Natural History Survey Bull. 26: 261 pp. Hartford.

Richardson, H. 1909. A monograph of the isopods of North America. Bull. U.S. Nat. Mus. 54:1-727.

Amphiphoda :

Bousfield, E. L. 1973. Shallow water gammariean Amphipoda of New England. Cornell Univ. Press. 313 pp.

Holmes, S. J. 1905. The Amphipoda of southern New England. Bull. U.S. Fish. Comm. 24:457-529.

Kunkel, B. W. 1918. The Arthrostraca of Connecticut. State Geological and Natural History Survey Bull. 26:261 pp. Hartford.

Mysidacea :

Tattersall, W. 1951. A review of the Mysidaceae of the United States National Museum. Bull. U.S. National Museum 201: 1-292.

Wigley, R. L. 1964. Part 1, Order Mysidacea. IN: R.I. Smith, Keys to the Invertebrates of the Woods Hole Region. Mar. Biol. Lab., Woods Hole, Ma. 93-145.

Decapoda :

Rathbun, M. J. 1905. Fauna of New England. 5. Crustacea. Occ. Papers Boston Soc. Nat. Hist. 7:1-117.

Rathbun, M. J. 1929. Decapoda. IN: Canadian Atlantic Fauna 10 m. Biol. Bd. Canada, St. Andrews. 1-38

Williams, A. B. 1965. Marine decapod crustaceans of the Carolinas. U.S. Fish. Wildl. Ser. Fish. Bull. 65:298 pp.

Echinodermata :

Clark, H. L. 1904. The echinoderms of the Woods Hole region. Bull. U.S. Fish. Comm. (1902) 22:545-576.

Coe, W. R. 1912. Echinoderms of Connecticut. State Geological and Natural History Survey. Bull. 19:1-152.

Deichmann, E. 1930. The helethurians of the western part of the Atlantic Ocean. Bull. Mus. Comp. Zool. Harvard. 71:43-226.

Verrill, A. E. 1895. Distribution of the echinoderms of northeastern America. A. J. Sci. Ser. 3, 49:127-141, 199-212.

TABLE II-2- 1 (Cont.)

Chordata :

Kingsley, J. S. 1901. Preliminary catalogue of the marine invertebrata of Casco Bay, Maine. Proc. Portland Soc. Nat. Hist. 2:159-183.

Van Name, W. G. 1910. Compound ascidians of the coasts of New England and neighboring British provinces. Proc. Boston Soc. Nat. Hist. 34:339-424.

Van Name, W. G. 1912. Simple ascidians of the coasts of New England and neighboring British provinces. Proc. Boston Soc. Nat. Hist. 34:439-619.

The small polychaete Mediomastus ambisetae may reach densities of over 4,000/sample in Long Island Sound. The majority of M. ambisetae individuals pass through a 1 mm screen and can be quantitatively separated from heavy material by decantation. It is suggested that if DAMOS moves to a 0.5 mm sieve size in Long Island Sound, the "fine light" fraction be split to reduce M. ambisetae numbers to 500-1,000/sample.

Samples of dredged material may contain up to 1 liter of residue >1 mm and 6 liters > 0.5 mm. In recently dumped material, the 1-0.5 mm heavy fraction may contain no animals and can be rapidly processed. At a later stage of succession, Mulina may be found in very high densities in a large volume of sand. The sand and the bivalves are the same size and are very time-consuming to separate. It is suggested that a smaller sample or a subsample be used to follow recolonization of small forms in Long Island Sound.

Rhode Island Sound -- The historical disposal site in Rhode Island Sound is unique in the presence of a dense bed of tube dwelling Ampeliscid amphipods (A. agassizi) surrounding the site and recolonizing deeper portions. The tubes of A. agassizi and other amphipods and polychaetes create a sieve residue of up to a liter. Amphipod densities may be as high as 3,500/0.1 m² sample. It is suggested that smaller samples be taken if studies are renewed in this area. Alternatively, more time should be assigned for sample sorting.

Foul Area -- Samples taken at the FADS reference station yielded very little residue >0.5 mm. Each sample was separated into >1 mm and 1-0.5 mm fractions. Several numerically dominant polychaetes were found in equal numbers on both sieves. Some polychaetes were retained only on the fine sieve. A core sample was sieved to 1, 0.5 and 0.3 mm. With the exception of one polychaete species, with juveniles, little information was gained from the 0.5-0.3 mm fraction.

Samples from Cape Cod Bay and from an area shoreward of FADS have yielded very large numbers of tube-dwelling polychaetes. These samples have a large sieve residue and a large number of taxa and individuals. If this type of community develops on dredged material, extra time or smaller samples may be required in processing.

Cape Arundel, Maine -- The CADS reference station was sampled in May, 1985. Sieve residue included five particles of marsh vegetation and red algae and bits of hard clay. This clay "sand" is too hard to wash away, but continues to release clay into the sample. Most of the organisms were removed from the clay by decantation and the clay examined in salt water which reduced clay release.

Rockland, Maine -- Reference samples from the Rockland site collected in 1984 were uniform, with high densities of the bivalve Nucula annulata and low sieve residue on the 1 mm sieve used at that time. Because the dominant species are long-lived (approximately 8 years) and about 5 mm long, they were adequately described using the coarser sieve.

2.3 Presentation of Results

Once the sorting and identification of the benthic organisms is complete, the data is tabularized. Table II-2-2 presents species count data for sediment samples collected at the Cape Arundel disposal site. The data is summarized as numbers of individuals and species (Table II-2-3). Table II-2-4 presents dominant species occurring at CADS.

3.0 SEDIMENT CHEMISTRY

Smith-MacIntyre grab samples of bottom sediment are collected for bulk sediment chemical analysis performed by the NED chemical laboratory. Once a grab sample is aboard ship, four short sections (approx. 15 cm) of plastic core liner (approx. 6.7 cm diameter) are imbedded into the sediment. Care is taken to obtain equal amounts of sediment in each core to the full depth of the sample. Three cores are analyzed as replicates while the fourth is analyzed for physical characteristics. Table II-3-1 and II-3-2 represent data sheets prepared by the NED laboratory when analysis is complete for the chemical and physical analysis, respectively. Table II-3-3 represents a summary of the chemical results

Table II-2-2
Benthic organism count-CADS

Cape Arundel: May, June 1984

	CTR	N100	E100	S100	REF
Cnidaria					
Edwardsia elegans	.	1	.	.	.
Melobolava producta
Melobolava duodecimcinnata	.	.	.	1	.
Heteractis aurata
Cerianthopsis americanus
Cerianthus borealis	.	.	2	.	.
Rhynchocoela					
Cerebratulus spp.	.	2	1	1	.
Micrura sp.	4	4	2	1	.
Tubulanus pellucidus	1
Tetrastemnidae	1
Rhynchosy	.	.	1	.	.
Phoronida: Species					
	1	5	1	.	.
Aplousobranchia: Species					
	5	2	1	.	.
Scaphopoda					
Siphonodentalium sp.
Gastropoda					
Neptunea decemcostata
Colus pubescens
Propebela sp. (Lora sp.)	.	.	1	.	.
gastropod C	2
Bivalvia					
Nucula annulata	2	.	.	2	.
Nucula delphinodonta	1	17	.	1	1
Nucula tenuis	2	3	.	.	.
Nuculana tenuisculata	.	1	.	.	.
Yoldia supotilla	2	1	1	.	1
Crenella decussata	.	2	.	.	.
Astarte undata	1	1	4	1	.
Cyclocardia borealis
Cerastoderma pinnatulum	4	7	.	.	.
Macoma calcaria	4	8	1	5	.
Arctica islandica
Thyasira flexuosa	3	9	4	12	2
Mya arenaria	4	13	1	11	2
Feriploma papyratium	8	8	10	.	1
Pandora gouldiana
Polychaeta					
Aphrodite hastata	.	.	1	.	.
Eteone trilineata	2
Phyllodoce arenae	2	.	.	1	.
Harmothoe extenuata	1	2	.	2	.
Hartmannia moorei
Phloe minuta	2	5	1	2	.
Goniada maculata



Table II-2- 2 (Cont.)

Cape Arundel Mo., June 1984

	CTR	N100	E100	S100	REF
SIFUNCULA
Phascolion strombi
HARPACTICOID COPEPOD
CUMACEA
Campylaepe rubicunda	.	1	.	.	.
Eudorella truncatula	2
Leucon nasicooides
Leucon americanus?
Diastylis sculpta	.	1	.	.	.
Diastylis sp.
ISOPODA
Edotea montosa	10	8	.	2	1
Pleurogonium spinosum
Ptilanthura tenuis	1	2	.	.	1
AMPHIPODA
Ampelisca agassizi
Ampelisca vadorum
Ampelisca verrilli
Ampelisca macrocephala	.	.	.	1	.
Haploope tubicola	4
Unciola irrorata
Anonyx liljeborgi
Anonyx sarsi
Hippomedon serratus	1	1	.	.	.
Orchomenella pinguis
Monoculodes sp.	.	.	.	1	.
Monoculodes sp Notch
Leptocheirus pinguis
Photis reinhardi	1
Harpina propinqua	.	.	.	1	.
Phoxocephalus holbolli
Stenopleustes inermis	1	1	.	.	.
Metopella angusta	3
Corophium tuberculatum	1
Dyopedeis monocantha
Caprella sp.
DECAPODA
Crangon septemspinosa
Pagurus longicarpus
ECHINODERMATA
Molpadia politica	.	.	.	1	.
Ctenodiscus crispatus
Ophiura sarsi	1	.	.	.	1
Abundance	493	528	331	381	56

SAIC

Table II-2-2 (Cont.)

Cape Arundel Bay, June 1964

	CTR	N100	E100	S100	REF
<i>Nephtys incisa</i>	7	5	5	14	.
<i>Eteugone verugera</i>
<i>Syllidae</i> sp.
<i>Nereis grayi</i>
<i>Capitella capitata</i>	.	2	.	1	.
<i>Heteromastus filiformis</i>	.	.	1	.	.
<i>Mediomastus ambiseta</i>	15	2	5	5	1
<i>Scalibregma inflatum</i>
<i>Scalibregma</i> sp.
<i>Clymenella zonalis</i>	.	1	.	.	.
<i>Madone sarsi</i>	154	30	1	9	15
<i>Rhodine attenuata</i>
<i>Fraxillella</i> sp.
<i>Sternaspis scutata</i>	20	43	25	25	1
<i>Laonice cirrata</i>
<i>Polydora quadrilobata</i>	.	.	.	1	.
<i>Polydora socialis</i>	.	.	1	.	.
<i>Frionospio steenstrupi</i>	32	36	26	11	.
<i>Spio setosa</i>	5	30	21	14	3
<i>Spiophanes bombyx</i>
<i>Apistobranhus tulbergi</i>	2	12	3	2	.
<i>Trochochaeta multiseta</i>
<i>Aricidea quadrilobata</i>	7	5	5	8	.
<i>Aricidea jeffreii</i>	3	4	10	.	.
<i>Spiochaetoperous oculatus</i>	1	1	.	.	.
<i>Faraonis gracilis</i>	15	11	15	23	7
<i>Oriloneris longa</i>
<i>Lumbrineris fragilis</i>	6	6	6	6	2
<i>Lumbrineris tenuis</i>
<i>Ninoe nigripes</i>	5	13	4	6	.
<i>Stauronereis</i> sp.	1
<i>Scoloplos acutus</i>	2	10	7	11	.
<i>Chaetozone</i> sp.	3	1	.	5	.
<i>Cossura longocirrata</i>	2	1	4	.	3
<i>Tharyx</i> A	4	15	.	.	1
<i>Tharyx</i> B	16	45	38	16	1
<i>Tharyx</i> spp.	10	14	29	19	3
<i>Myriochele heeri</i>	20	39	23	37	1
<i>Dwenia fusiformis</i>	1	7	.	2	.
<i>Pectinaria gouldii</i>
<i>Polycirrus</i> sp.	1	.	1	.	1
<i>Anobothrus gracilis</i>	7	4	3	2	.
<i>Melinna cristata</i>	1	1	1	.	.
<i>Terebellides stroemi</i>	2	5	1	4	.
<i>Terebellidae</i>
<i>Brada villosa</i>	.	1	.	.	.
<i>Pherusa affinis</i>
<i>Diplocirrus</i> sp.	1	1	.	.	.
<i>Chone infundibuliformis</i>
<i>Euchone incolor</i>	10	4	10	9	1
polychaeta unidentified	2

OLIGOCHAETA SPECIES	56	84	50	102	3



Table II-2-3

Dominant Species - CADS

Polychaeta

Aricidea quadrilobata

Euchone incolor

Lumbrineris fragilis

Maldane sarsi

Mediomastus ambiseta

Myriochele heeri

Nephtys incisa

Ninoe nigripes

Paraonis gracilis

Prionospio steenstrupi

Scolopos acutus

Spio pettiboneae

Steraspis fossor

Tharyx spp.

Bivalvia

Sphenia sincira

Nucula delphinodonta

Periploma papyratium

Thyasira flexuosa

Oligochaeta spp.

Table II-2-4

Number of Individuals and Species - CADS

Station	CTR	N-100	E-100	S-100	REF	TOTAL
Individuals	493	538	331	381	56	1799
Species*	58	54	40	41	24	82
*Species with more than 2 individuals						62

II-17



Table II-3-1
 Results of Chemical Analysis
 New England Division, Corps of Engineers
 Results of Chemical Analysis - DAMOC -
 Chemical Samples
 Central Long Island Sound Disposal Site - Norwalk Area
 Summer Cruise - August/September 1982

Test	Field Log No./Sample Locations				
	2775 150W-B	2776 150W-C	2778 300W-A	2779 300W-B	2780 300W-C
% Solids	45.9	50.7	49.4	51.3	47.7
% Volatile Solids, EPA	6.35	6.84	5.61	5.32	6.32
% Volatile Solids, NED	4.16	4.66	4.12	4.00	3.73
Chemical Oxygen Demand, ppm	79,500	69,700	70,800	61,300	63,500
Oil and Grease, ppm	-	-	160	-	-
Phosphorus, ppm	-	-	-	-	-
Ammonia, ppm	51	18	16	20	22
Mercury, ppm	0.57	0.89	0.27	0.28	0.32
Lead, ppm	53	140	56	36	43
Zinc, ppm	256	268	176	168	225
Arsenic, ppm	3.2	2.2	1.5	3.4	2.6
Iron, ppm					
Cadmium, ppm	*	*	*	*	*
Chromium, ppm	50	78	64	61	47
Copper, ppm	134	149	97	81	65
Magnesium, ppm	9,050	8,720	8,550	7,740	8,410
Nickel, ppm	*	46	*	*	*
Calcium, ppm	800	800	800	1,300	5,400
Vanadium, ppm	*	*	*	*	*
PCB, ppb	-	-	-	-	-
DDT, ppb	-	-	-	-	-
% Total Carbon	3.05	3.18	2.18	2.12	2.99
% Total Hydrogen	0.64	0.62	0.50	0.46	0.60
% Total Nitrogen	0.26	0.26	0.18	0.17	0.23

Table II-3-2

Results of Physical Testing

NEW ENGLAND DIVISION, CORPS OF ENGINEERS
 RESULTS OF PHYSICAL TESTING - DAMOS
 Central Long Island Disposal Site - Norwalk Area
 Chemistry Samples - August/September Cruise 1982

Test	Field Log No./Sample Locations				
	2651 CTR-A	2665 150W-A	2665 300E-A	2679 450E-A	2777 300W-A
Visual Classification	Dk grey organic fine sandy silty clay (OH) with shell fragments	Dk grey organic fine sandy silty clay (OH) with shell fragments	Dk grey organic fine sandy silty clay (OH) with shell fragments	Dk grey organic silty clay (OH) with trace sand	Dk grey organic fine sandy silty clay (OH) with shell fragments
Grain Size Curve					
Med (50)	0.0110	0.0130	0.0110	0.0140	0.0097
Q1 (75)	0.0290	0.0180	0.0240	0.0270	0.0030
Q3 (25)	0.0028	0.0057	0.0035	0.0050	0.0022
Soil Class/ Dominant	OH	OH	OH	OH	OH
Normal/ Bimodal	N	N	N	N	N
% Fines: (pass #200 US Std Sieve)	85	88	90	95	88
Specific Gravity	2.60	-	-	2.62	-
Radioactivity (Mr/hr)/bkg	21/170	16/170	21/180	20/180	22/180

Table II-3-3

Summary of Chemical Results

Interpretation of Test Results
 Central Long Island Sound - Norwalk Area
 Summer Cruise - August/September 1982

Location	Sediment Type	% Volatile Solids NED	COD ppmx10 ⁻⁵	Fe ppmx10 ⁻⁴	NH ₃ ppm	Hg ppm	As ppm	Pb ppm	Zn ppm	Cr ppm	Cu ppm	C:N	Mg ppm	Ca ppm	Mg:Ca
450E-A	sandy	2.59	0.55	2.59	93	*	4.4	160	170	60	97	10.3	8,820	7,500	1.2
B	silty	4.49	0.92	2.39	42	0.22	4.4	180	180	74	71	13.6	6,230	880	7.1
C	clay	5.29	0.53	2.51	36	0.17	3.6	140	170	57	153	10.1	7,630	850	9.0
300E-A	sandy	5.13	0.54	2.68	150	0.41	0.9	240	220	42	79	11.2	7,520	1,200	6.3
B	silty	3.66	0.53	2.42	65	0.12	4.0	120	250	54	67	10.5	7,780	3,060	2.5
C	clay	6.19	0.92	1.96	110	0.09	2.8	160	310	120	220	17.3	3,100	4,800	0.7
CTR-A	sandy	4.60	0.91	2.77	43	0.11	10.2	180	290	78	170	11.4	7,970	730	10.9
B	silty	4.53	0.72	1.46	17	0.42	7.9	130	180	52	120	10.3	6,670	680	9.8
C	clay	4.06	0.52	2.65	73	0.18	5.6	180	230	71	170	11.7	7,620	650	11.7
150W-A	silty	4.94	1.15	3.05	62	0.95	4.4	140	317	81	153	16.2	8,430	900	10.5
B	clay	4.16	0.80	-	51	0.57	3.2	53	256	50	134	11.7	9,050	800	11.3
C		4.66	0.70	2.74	18	0.89	2.2	140	268	78	149	12.2	8,720	800	10.9
300W-A	sandy	4.12	0.71	2.95	16	0.27	1.5	56	176	64	97	12.1	8,550	800	10.7
B	silty	4.00	0.61	2.58	20	0.28	3.4	36	168	61	81	12.5	7,740	1,300	6.0
C	clay	3.73	0.64	2.48	22	0.32	2.6	43	225	47	65	13.0	8,410	5,400	1.6
REF-A	sandy	4.34	0.44	2.54	48	*	5.1	140	170	55	55	9.4	7,740	1,400	5.5
B	clayey	4.70	0.60	2.52	54	*	5.7	160	160	55	56	9.4	8,070	1,900	4.2
C	silt	4.19	0.56	2.28	93	*	4.0	100	150	49	49	9.3	6,850	1,400	4.9

*Below minimum detection limit.

III. STANDARD OPERATING PROCEDURE FOR DAMOS MUSSEL WATCH

1.0 OBJECTIVES OF THE MUSSEL WATCH PROGRAM

Mussels are now globally established as acceptable indicator organisms for monitoring pollutant levels in the marine environment. Most field investigations have involved only samplings of intertidal or subtidal populations on a short term basis; few investigators have attempted long term, in-situ monitoring of Mytilus sp. because of the obvious weather-related and logistical difficulties confronting such field studies. However, the DAMOS program has developed a system for the long-term in situ monitoring of Mytilus edulis at offshore dredged material disposal sites in Long Island Sound.

The objective of the Mussel Watch Program is to monitor the possible deleterious effects of the disposal activities in Long Island Sound. To accomplish this, the following questions have been investigated:

- o Is there any evidence suggesting that there are increases in trace metals and polychlorinated biphenyls (PCB) in M. edulis associated with open water disposal of dredged materials, or other environmental factors?
- o If so, are there any indications that dredged material has spread beyond the boundaries of designated disposal sites?
- o Is there any physiological change, e.g., tissue wet/dry weight ratio, gonadal development in M. edulis, etc. that can be attributable to the increase in tissue trace metal and PCB concentrations or to other biological factors?
- o Is there any discernible histopathological change that can be correlated with the increase in tissue trace metal and PCB concentrations?

2.0 FIELD OBSERVATION PROCEDURES

Genetic and other variations such as temperature dependent filtering rates and reproductive cycles in natural populations of mussels contribute to variations in trace metal and PCB concentrations in their tissues. In order to minimize these variations, a single stock of subtidal mussels is used to both provide baseline concentrations and to stock monitoring platforms deployed at designated sites. Ten baseline samples (eight mussels per sample) are collected just prior to the deployment of platforms at the disposal site. Samples from monitoring platforms deployed at the disposal and reference sites as well as at the location where stock mussels were obtained are

then concurrently sampled at monthly intervals. Data on shell length and width, tissue wet/dry weight ratios as well as trace metal and PCB concentrations are obtained.

While disposal operations are underway, dive surveys are used to determine the margins of recently dumped material to allow placement of monitoring platforms close to the margins. Experience has shown that platforms can be positioned within 50 meters of the margin of newly dumped material without danger of burial by subsequent disposal operations. Following the conclusion of disposal operations, platforms can easily be redeployed in the center of the mound, directly atop recently dumped material.

2.1 Monitoring Platforms

Platforms (Figure III-2-1) are constructed of 4.7 cm O.D. polyvinylchloride pipes and polyvinylchloride fittings, measuring 100 cm x 100 cm square on top and fitted with 80 cm legs. Cross members in the middle of the legs and top provide reinforcement. Circular cement footings weighing 20 kg each are poured around the base of each leg for stability. A polypropylene bridle is attached to the top of each platform for lifting purposes and to provide a point of attachment for surface buoys. The completed platform with mussels weighs 115-140 kg in air. Mussels are placed in commercially available polypropylene mesh bait bags (50 cm long with 2.5 cm stretched mesh) and secured to the top of the platform with all-plastic electrical "cable ties." Mussels greater than 2 cm shell length are selected to avoid loss through the mesh bag. In order to obtain growth data, all mussels in randomly selected bags are measured before deployment. Bags containing measured mussels are then coded with knotted polypropylene line so that divers can identify specific bags even under zero visibility conditions.

In areas where ship traffic and trawling activities are minimal, large buoy systems are used to mark the location of the experimental platforms. Buoys made of 1.5 m diameter hemispherical steel are secured with 2.3 cm nylon line to 700-900 kg cement anchors. In order to prevent contamination, no metal hardware should be used in the buoy rigging. The platform is secured to the anchor by a 10 m polypropylene groundline staked to the bottom. The groundline, rigged to break free from the platform in the event the buoy and anchor are dragged off station. A radar reflector and anchor light are affixed to a 1 m high tower atop each buoy.

In areas subject to heavy ship traffic and intense trawling activities, a small, detachable buoy array is employed. A redundant system consisting of a primary buoy (1 cm polypropylene line with a 28 cm spongex float) and a subsurface auxiliary safety float (same material as the primary buoy) should be used. These floats make the platforms less conspicuous and less vulnerable to ships because they often remain underwater except during slack current. The line (Figure III-2-1) for the auxiliary buoy is coiled and attached to the platform with a single cable tie. A loop is tied in the bitter end of the

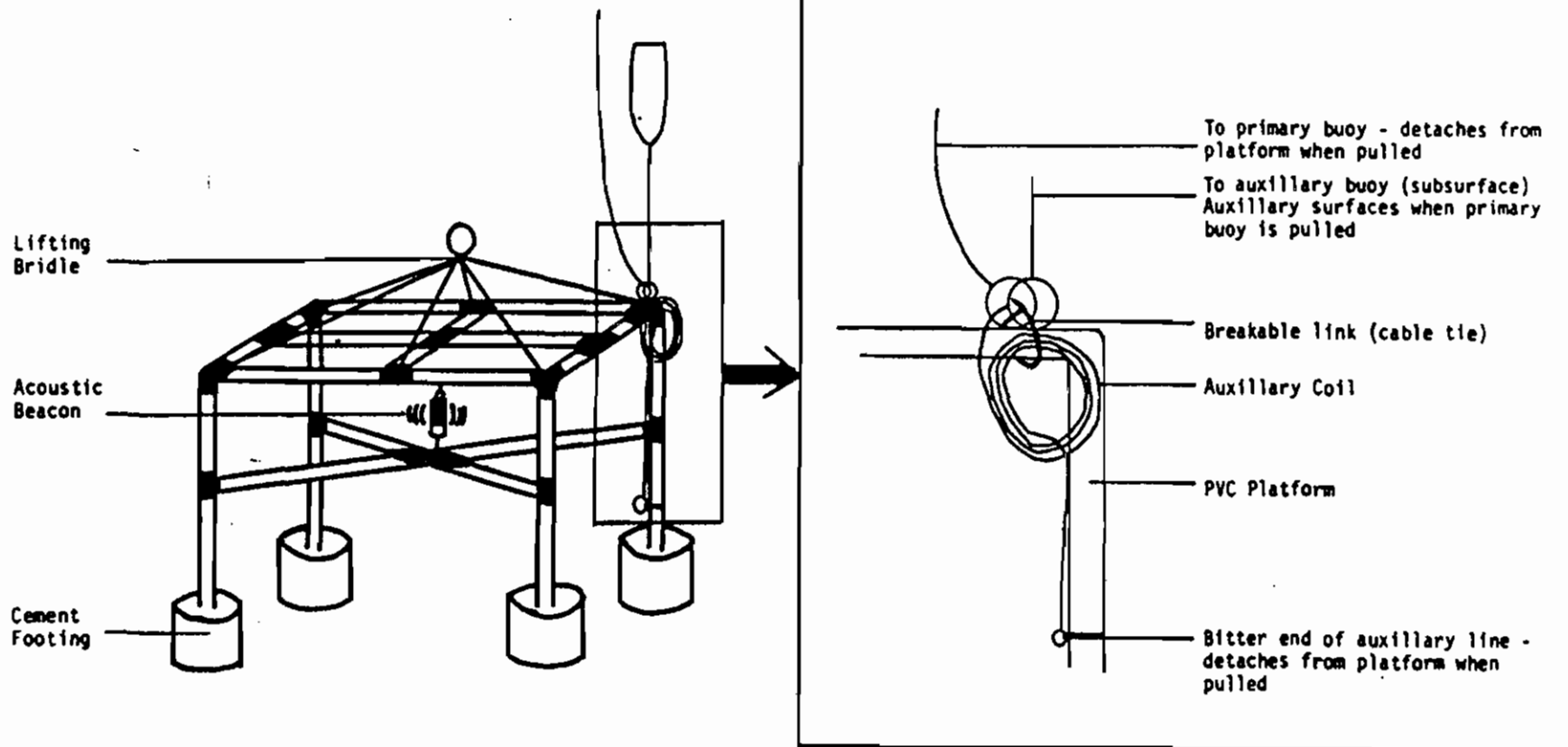

Figure III-2-1. Schematic diagram of the PVC sampling platform. Inset shows detail of buoy release rigging.

primary line and is also secured to the auxillary coil with the same cable tie. If sufficient pressure is applied (ca. 50 lbs) to the primary line it breaks away, releasing the auxillary coil and buoy, thus causing the auxillary buoy to surface. The bitter end of the auxillary buoy is also attached with a single cable tie allowing it to break away from the platform. The breaking strength of the cable ties is designed in such a manner as to enable divers to descend on the buoy lines in current less than 1/2 kt without detaching the buoys.

An acoustic pinger is attached to each platform to aid divers in locating it when the buoys are submerged or missing. Pingers should be secured with polypropylene line between the upper and lower cross members to minimize the chance of burial in the event the platform is overturned. The pingers operate at 40 kHz and should have a working range of approximately 1/4 nautical mile. Divers can follow the signal using a hand-operated variable frequency acoustic receiver. In areas where multiple platforms are deployed in close proximity, pingers of different pulse rates: 1, 3, or 6 pulses per second, are recommended to differentiate them.

2.2 Deployment and Sampling Procedures

Stations are chosen by predeployment dive surveys to determine suitable bottom type. Every effort is made to deploy platforms as close as possible to the disposal mound and yet avoid complete burial of the platform by direct barge release. Just prior to deployment, two bags from the stock of mussels to be used as the baseline sample are removed for laboratory analysis. The remaining bags of mussels, acoustic pinger and buoy system are attached to the platform while aboard the ship. The completed unit is then lowered to the seafloor using a ship's winch. Divers then enter the water to release the surface cable, inspect the rigging, and record the orientation of the platform on the seafloor. Finally, a brief visual survey is made of the immediate area before surfacing.

Stations are relocated using Loran-C coordinates. Visual sighting of either the primary or auxillary buoys will confirm the platform location. Divers must carefully descend the buoy line to avoid detaching it from the platform. If surface floats are not observed, a reference buoy is deployed at the Loran-C coordinates of the station and an in-water search performed using the acoustic receiver. The dive team should tow an additional buoy to remark the station.

Once a platform is located, divers collect the required number of sample bags, remove accumulated sediment, and count the remaining bags. Divers can also re-rig the buoy system, inspect the platform for damage and replace the acoustic pinger as required. The amount of in-water time required to locate, sample and service each platform normally ranges between 5 to 25 minutes. At some locations in Long Island Sound predation on the mussels by the tautog, Tautoga onitis, and by starfish, Asterias forbesi may deplete mussels, necessitating restocking by divers.

This sampling system demands a high level of diving effort. Continuous monitoring often requires between-sampling maintenance diving to remove fouling organisms and to ensure buoy arrays are in good working order. During the summer months, the mesh bags are heavily fouled by hydroids, colonial ascideans, ectoprocts and juvenile mussels. Hand cleaning of the bags is required during that time of year. Resuspension of bottom sediments also causes an accumulation of material which also needs periodic removal. This problem is especially acute in central and western Long Island Sound because of the predominantly fine silty sediments which are easily resuspended by tidal exchange and storm induced turbulence.

Sampling by divers in depths exceeding 40 meters is not recommended because working time is severely limited. At depths exceeding 40 meters, the platforms should be deployed with a subsurface buoy array secured with an in-line acoustic release. Diving should be employed as a last resort at such sites to recover the samples only when the acoustic release malfunctions.

3.0 ANALYSIS PROCEDURES

During each monthly sampling period, triplicate samples of eight mussels are collected. For baseline data, 10 replicates are used. In the laboratory, the mussels are cleaned, measured, shucked and homogenized. An aliquot of the homogenized sample is weighed (wet weight) and lyophilized using a Virtis Model 10-010 freeze drier. After drying overnight in the apparatus, the freeze dried tissue is weighed again, and designated as the "dry weight." The wet-dry weight ratio is calculated by dividing the wet weight of the tissue by the freeze dried tissue weight.

3.1 Trace Metal Analysis

Approximately 0.8 g of freeze dried tissues placed in an acid cleaned glass volumetric flask are digested in 5 ml Ultrex concentrated nitric acid for six hours at 50° C and then diluted to a final volume of 50 ml with deionized glass distilled water (DIDW). The diluted sample is filtered through an acid cleaned and pre-rinsed Millipore glass fiber filter to remove particulate materials which tend to block the aspirator, particularly when performing flame atomic absorption spectrophotometry.

Copper, iron and zinc are analyzed by the conventional flame atomic absorption spectrophotometry using an Instrumentation Laboratory Model 151 Atomic Absorption Spectrophotometer. Cadmium, chromium, cobalt, nickel and vanadium are analyzed by graphite furnace flameless atomic absorption spectrophotometry (Perkin Elmer Model 5000 AA and HGA 500 Graphite Furnace). Mercury is determined using a cold vapor flameless atomic spectrophotometer (Coleman MAS-50) after reduction of oxidized mercury to Hg with stannous chloride. Results were corrected for reagent blanks and calibrated by comparison with standard solutions of metal salts in 10% vol/vol nitric acid in DIDW. Similarly prepared samples of a

standardized reference material (NBS #1566 Oyster Tissues) are analyzed concurrently with the mussel samples as quality control of the analytical results.

Throughout the analysis of trace metals and PCB's, meticulous care is taken to minimize contamination, particularly in cleaning laboratory glassware and plastic ware.

All glassware is washed with Acationox, rinsed with tap water, followed by three rinses with glass distilled water; these are soaked overnight in 50% nitric acid made up in glass distilled water, rinsed three times with deionized distilled water and once with 2% Ultrex nitric acid in deionized distilled water, followed by three rinses with deionized water. Plastic ware is immersed in acetone and rinsed three times with tap water to remove plasticizers and other soluble residues from the manufacturing process. After this pretreatment, the plastic ware was cleaned following the procedure outlined for the glassware.

3.2 Analysis of Polychlorinated Biphenyls

Triplicate freeze-dried tissue samples prepared for trace metal analysis are pooled and analyzed for PCB content. One gram of the pooled freeze-dried tissue is soxhlet-extracted for 3 hours with nanograde petroleum ether (Mallinckrodt Inc., St. Louis, Missouri). The extract is concentrated with Kuderna-Danish apparatus to 2 ml. One ml of the concentrate is archived and stored in the refrigerator; the remaining aliquot is cleaned by chromatography with a Florisil (Fisher Scientific Co., Fair Lawn, New Jersey) packed column (Reynolds, 1969). The extract is eluted with nanograde n-hexane (Mallinckrodt Inc.); the eluent is concentrated to 1 ml with Kuderna-Danish apparatus and followed by gas chromatography using a 2m x 4mm packed glass column of 3% OV-1 (methyl silicone gum) on a silane-treated diatomite support of 100/120 mesh Gas Chrom Q (Applied Science Labs, State College, Pennsylvania). The analyses are carried out isothermally using a Hewlett Packard, Gas Chromatograph equipped with a 63 Ni electron capture detector (detector 300°C; injection port, 225°C; oven, 200°C). A mixture of 95% argon and 5% methane is used as the carrier gas. Aroclors 1242, 1254 and 1260 are used as standards for quantification purposes.

Quantifications of Aroclors are achieved by employing a microcomputer equipped with CHROMATOCHART software (Interactive Microware, Inc., State College, PA). After the data collection is completed, the software first computes retention time and actual concentrations for each peak of Aroclors 1242, 1254 and 1260 to be used as external standards and stored in the memory. The data collected from the injection of prepared samples are computed in the same manner as the standards; the retention time of each peak is compared with that of the standards and then identified. A comparison of the results obtained from the manual method with the present procedure has shown a deviation of no more than 5%.

3.3 Histopathological Studies

Samples obtained for histopathological analysis are first treated with formalin aboard ship. To aid fast penetration of the neutral buffered formalin into the soft tissues of the mussels, one valve of each animal is cracked with a sharp blow using the handle of a knife, and the shell liquor drained. The mussel is then immersed in the fixative making sure that air is not trapped inside the mantle cavity. To standardize the section, cross sections of the mussels are cut just anterior to the foot. The sections are further processed and stained with hemotoxylin and eosin using the standard histological procedures of the Histology Laboratory of the Department of Pathobiology.

Finished histological preparations are examined with an Olympus VANOX microscope at magnifications of 4X, 20X and 40X. Each specimen is critically scrutinized for stages of gonadal development, staining characteristics of the Leydig tissue, tissue integrity of the gill, kidney tubules, and intestinal epithelium, as well as the degree of leucocytic infiltrations. In addition, the prevalence of parasitic infections by *Proctoeces maculatus* and *Chytridiopsis mytilovum* is noted.

3.4 Statistical Analysis of the Data

In interpreting the field experimental data on the uptake of trace metals and PCB in mussels, one must recognize several constraints which delineate limits of the interpretation. It is desirable to separate the effects of normal physiological activities from those which truly result from anthropogenic activities. However, the field experiment is correlational; thus, causation cannot be assumed simply on the basis of high correlation. In addition, field investigations are unlike laboratory experiments where independent variables can be controlled and the response of the organism to them accurately measured.

Prior to performing any statistical procedure, the data set is tested for normality. Where normality of the data set is not sufficient, appropriate transformations are employed to satisfy the conditions required by conducting proper statistical procedures. For the two-way ANOVAs, the data should be classified by station (spatial) and sampling period (temporal), i.e., during or after dumping. This procedure is used to test the null hypotheses that the mean trace metal or PCB concentrations of the mussels from the monitoring populations are not different either during or after dumping. If the null hypotheses are rejected, multiple range test is applied to discern which station(s) is different.

Stepwise multiple regression analysis are used to reveal relationships among trace metal and PCB concentrations, intrinsic (physiological) and extrinsic (environmental) parameters. This statistical procedure determines whether the variance in the trace metal and PCB concentrations of the mussels can be accounted for by any or all of the intrinsic variables: wet/dry weight ratio, length of the mussels, and extrinsic

variables: the volume of dredged material dumped, the ambient water temperature, the riverine discharge and the month when samples were collected. Based on previous work, wet/dry weight ration and length of the mussels accounted for a major portion of the observed variance of trace metal concentrations. This procedure may be viewed as a technique to factor out contributions of intrinsic variables to the variance, which is important, because one of the major objectives is to determine which extrinsic factor(s) contribute significantly to the variance. Therefore, the intrinsic factors are programmed to enter the regression model first. Other extrinsic variables or independent variables are sequentially entered into the regression functions dictated by their absolute or partial correlations with the dependent variables, i.e., concentration of trace metals or PCB's.

4.0 PRESENTATION OF RESULTS

Once the analyses of the mussel tissue are completed and statistics have been conducted to determine significant trends in the data, the results are presented in various forms. Table III-4-1 is a summary of results for mussels collected in Eastern and Western Long Island Sound. Results of significant analysis of variance (ANOVA) and Tukey's test are also presented. Table III-4-2 presents further results from two-way ANOVA and the Scheffe groupings which tend to link similar sample populations. Elemental enrichment factors (Table III-4-3) are calculated to detect significant increases in concentration. Figure III- 4-1 depicts a typical plot of total PCB concentration in mussels from various test populations. Table III-4-4 presents frequencies of infection in mussels at several test sites.

Table III-4-1

Summary of wet/dry ratios (W/D), shell length (L) and tissue metal concentrations (ppm) in Mytilus edulis deployed at four stations in Eastern and Western Long Island Sound from June to September 1984.

	Rlr	Stations WLISrN	WLISc	500 MW
W/D	7.11 ± 0.78	8.08 ± 1.39	7.31 ± 0.36	7.79 ± 0.81
L	6.95 ± 0.24	6.92 ± 0.14	7.00 ± 0.03	7.09 ± 0.32
Cd	0.72 ± 0.19	1.30 ± 0.51	1.06 ± 0.31	1.02 ± 0.30
Cr	3.25 ± 0.99	7.88 ± 11.46	2.06 ± 1.06	1.85 ± 1.42
Co	0.43 ± 0.20	0.76 ± 0.51	0.48 ± 0.27	0.40 ± 0.25
Cu	8.29 ± 0.89	8.94 ± 0.25	8.56 ± 0.33	8.49 ± 0.36
Fe	227 ± 77	203 ± 95	136 ± 18	146 ± 15
Hg	0.184 ± 0.015	0.176 ± 0.007	0.170 ± 0.019	0.152 ± 0.014
Ni	3.23 ± 0.92	5.39 ± 4.84	2.25 ± 0.32	2.89 ± 1.03
Zn*	121 ± 18	152 ± 8	142 ± 18	120 ± 10
V	2.04 ± 2.54	0.91 ± 0.50	0.75 ± 0.14	0.69 ± 0.17
n	5	3	3	3

* One-way ANOVA significant. F = 3.76, d.f. = 6, p < 0.049

Tukey's Groupings (α = 0.05):

Zn	WLISrN 152	WLISc 142	Rlr 121	500MW 120
----	---------------	--------------	------------	--------------



Table III-4-2

Summary Of Two-Way ANOVA For Cd, Cu, Zn, Ni, V and W/D

	Cd ¹	Cu	Zn ¹	Ni ²	V	W/D
Station (S)	***	***	***	NS	NS	NS
Time (T)	*	***	**	**	***	**
SXT	NS	NS	NS	NS	NS	NS
Scheffe Grouping $\alpha = 0.05$	WLIS MQO CLISr 1000ME MQN LAT D<A	WLIS MQN 1000ME MQO CLISr LAT D>A	WLIS MQO CLISr 1000ME MQN LAT D<A	D>A	D>A	D<A

1. ln Cd; 2. \sqrt{Ni} ; NS = non significant; * p<0.05; **p<0.01; ***p<0.001; D = during disposal; A = after disposal; 2-way ANOVA for Cr, Co, Fe and Hg were not significant.



Table III-4-3

Elemental Enrichment Factors In Surficial Sediments Obtained From
Western Long Island Sound Disposal Sites (Derived From March/April
And June 1984 Cruise Data)

Element	Station			Station			Station		
	A-CTR March/April 1984	400MW	REF	A-CTR	200MW	B-CTR June 1984	400MW	REF	
Cd	24	*	*	54	22	*	34	*	
Cr	2	2	1	1	1	1	2	1	
Cu	3	3	1	3	3	4	3	3	
Hg	7	3	3	5	6	5	2	2	
Ni	1	1	1	2	2	2	1	1	
Zn	6	8	4	13	10	11	10	6	

* Concentrations below detection limits; EF not calculated.
EF \leq 5 is considered not enriched.

Table III-4-4

Frequencies of Pinnotheres Maculatus Infection In Mytilus Edulis Maintained At RIr, WLISrN and WLISc From June Through September 1984

Station	<u>Pinnotheres</u> Infection		Totals	% <u>Pinnotheres</u> Infection		Totals
	Infected	Non-infected		Infected	Non-infected	
RIr	56	16	72	77.8	22.2	100
WLISrN	59	7	66	89.4	10.6	100
WLISc	16	4	20	80.0	20.0	100
Totals	131	27	158			

GT - test Statistics: $G = 3.564$, d.f. = 2, $\chi^2_{0.1(2)} = 4.605$, $p > 0.10$

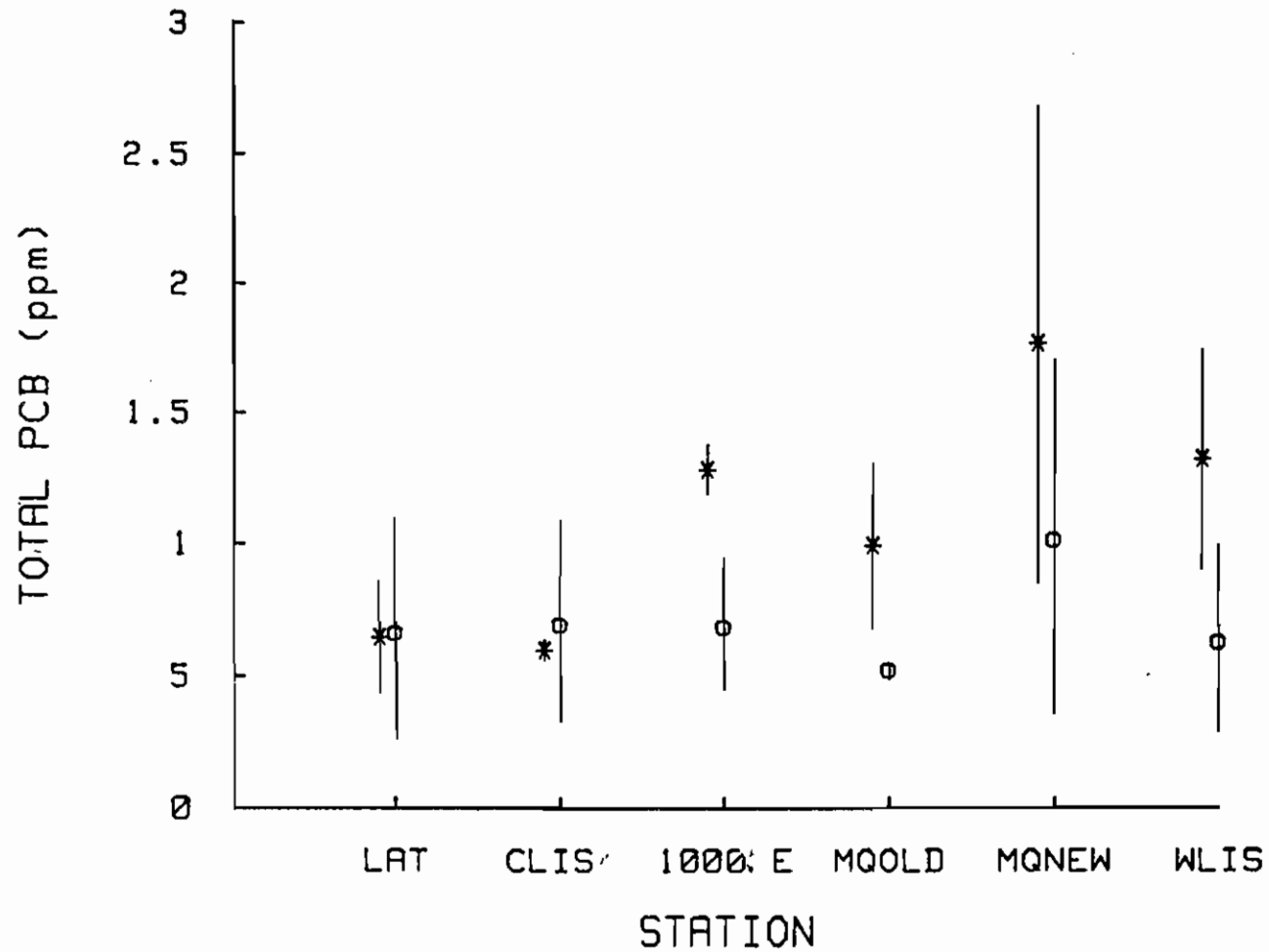

Figure III-4-1. The mean concentrations of total PCB during (*) and after (o) dumping operations in the six mussel monitoring populations maintained at the Eastern, Central and Western Long Island Sound sites.

IV. STANDARD OPERATING PROCEDURES FOR SPECIAL EQUIPMENT AND OBSERVATIONS

1.0 IN-SITU SEDIMENT-PROFILE IMAGING, DATA ANALYSIS, AND MAPPING

1.1 Objectives

In situ sediment-profile imaging (REMOTS) is a rapid means of obtaining synoptic information about surficial seafloor structures and benthic processes. This data is obtained with commercially available sediment-profile cameras which are designed to cut an undisturbed vertical profile into bottom sediments. The resulting vertical profile of the sediment column, sediment-water interface, and supernatant water is recorded on photographic film for subsequent computer image analysis. This method of in situ 'optical coring' permits imaging of up to 20 cm. of the sedimentary column in high resolution. This optical system is not affected by ambient turbidity nor ambient light levels.

A distinct advantage of the REMOTS system is the rapid turnaround time for obtaining preliminary results. Photographs taken during the cruise can be developed that night for immediate evaluation of bottom substrate. Results of REMOTS imagery are often used to determine sampling locations on subsequent cruise days. REMOTS imagery has been especially useful in determining the extent of dredged material layers too thin to be detected acoustically.

1.2 Instrument Deployment and Operational Requirements

The sediment-profile camera should be of a dimension and weight that will allow safe deployment from a vessel with a length of about 40 feet or larger. Once the vessel is positioned on station, the deployment and recovery rate of the instrument should allow for three replicate station images to be taken within a period of five minutes in water depths of less than 30 meters. Efficient vessel positioning with respect to closely spaced stations and within station replicates requires a precision navigational system with real-time updating of vessel position graphically displayed to the helmsman on a video display (see Section I).

The instrument must be designed so that the "bow-wave" associated with its deployment will not disturb the sediment surface to be imaged. The instrument must also be designed so that it can be deployed and physically supported on soft muds without compromising its operational efficiency. The optical system must have an optical resolution of at least 62 micrometers, i.e. the images must be able to discriminate between coarse silt and very fine sand (Udden-Wentworth grain-size nomenclature). High ambient bottom turbidity and variable ambient light conditions must not adversely affect image quality.

Internal illumination of the sediment-profile camera must provide for a uniform lighting field with no hotspots, light gradient artifacts, or internal reflections.

The film capacity of the system should be at least 36 exposures and the camera system should be compatible with a pinger which allows for remote monitoring of its operational sequence (triggering, film advance, and re-arming of the strobes).

Given the variability of bottom types and their "hardness", the camera should also allow for control of the penetration depth of the optical prism into the bottom. This is controlled by adding or removing modular weights and/or setting mechanical "stops" on the descending optical prism.

While several sediment-profile cameras exist, SAIC has found the Benthos REMOTS sediment-profile camera to best meet all of the above requirements. Efficient vessel positioning is provided by the SAIC Navigation System.

REMOTS sampling locations at existing disposal sites were determined by the extent of dredged material measured acoustically and by visually characterized sediment grab samples. The stations are spaced to allow images to be obtained both on the disposal mound and beyond the farthest extent of the material. Table IV-1-1 presents the stations occupied for most of the DAMOS disposal sites. The same naming convention used for sediment sampling is also utilized here.

When areas are being investigated for designation or relocation, a sampling grid is constructed to allow complete coverage of the area. Further sampling will be determined from these preliminary results. Tables IV-1-2 and IV-1-3 present stations at CADS and FADS, respectively, that were sampled with REMOTS.

1.3 Image Analysis

The resulting sediment-profile images are measured for several parameters. The list of potentially available data includes, but is not restricted to: modal grain-size and grain-size range, sediment surface boundary roughness, prism penetration depth, presence of mud clasts, presence of methane gas pockets, the mean depth of the apparent redox potential discontinuity (RPD), ripple parameters, erosional features, the thickness of recently deposited sedimentary intervals (RDSI's), buried relict RPD zones, rebounded RPD's, the presence of subsurface feeding voids, the presence of dense tube aggregations at the sediment surface, the number of tubes per linear transect across the interface, and the presence of epifauna.

The estimate of sediment texture is based on overlaying photographed grain-size standards (Udden-Wentworth scales) onto positive prints of sediment profile images. The standards are prepared by photographing sieved (wet) aliquots through the sediment-profile camera system. Comparison of estimates of major

Table IV-1-1

REMOTS Sampling Stations

<u>NL</u>	<u>NL III</u>	<u>DGC</u>	<u>NLON</u>
100N	100N	100N	200N
300N	200N	200N	400N
100S	300N	100S	200S
300S	100S	400S	400S
100E	200S	100E	200E
300E	300S	200E	400E
100W	100E	100W	200W
300W	200E	200W	400W
CTR	300E	CTR	CTR
	100W		
	200W		
	300W		

<u>FVP</u>	<u>NH-83</u>	<u>NH-74</u>	<u>STNH-N</u>
200N	250N	200N	100N
250N	400N	400N	200N
400N	250S	200S	100S
200S	500S	400S	250S
300S	200E	200E	200E
400S	600E	400E	400E
150E	200W	200W	150W
250E	600W	400W	300W
400E	700W	CTR	CTR
500E	200N/E		
1000E	200N/W		
100W	200S/E		
250W	200S/w		
500W	CTR		
750W			
1000W			
CTR			



Table IV-1-1 (Cont.)

<u>STNH-S</u>	<u>NORWALK</u>	<u>MQR</u>	<u>CS-1</u>
100N	100N	100N	200N
200N	300N	200N	200S
100S	150S	400N	400S
250S	450S	100S	500S
100E	150E	300S	200E
300#	300E	350S	400E
400E	150W	100E	200W
150W	400W	300E	500W
250W	CTR	400E	600W
CTR		100W	CTR
		300W	
		500W	
		CTR	
<u>CS-2</u>	<u>CLIS</u>	<u>WLIS-B</u>	<u>WLIS-A</u>
200N	REF	100N	100N
300N		200N	200N
200S		300N	100S
300S		400N	200S
100E		100S	100E
200E		200S	200E
500E		300S	100W
100W		400S	200W
200W		100E	CTR
400W		200E	REF
500W		300E	
CTR		400E	
		100W	
		200W	
		300W	
		400W	
		400N/E	
		400N/W	
		400S/E	
		400S/W	
		CTR	



Table IV-1-2

REMOTS at CADS

Parameters for PARAM:CADSHLM
Page 16

Waypoints:

1A	43	18.271N	070	27.207W	9625.00	1987.00
2A	43	18.244N	070	27.207W	9625.00	1937.00
3A	43	18.217N	070	27.207W	9625.00	1887.00
4A	43	18.190N	070	27.207W	9625.00	1837.00
5A	43	18.163N	070	27.207W	9625.00	1787.00
6A	43	18.136N	070	27.207W	9625.00	1737.00
7A	43	18.109N	070	27.207W	9625.00	1687.00
8A	43	18.082N	070	27.207W	9625.00	1637.00
9A	43	18.055N	070	27.207W	9625.00	1587.00
10A	43	18.028N	070	27.207W	9625.00	1537.00
11A	43	18.001N	070	27.207W	9625.00	1487.00
12A	43	17.974N	070	27.207W	9625.00	1437.00
13A	43	17.947N	070	27.207W	9625.00	1387.00
14A	43	17.920N	070	27.207W	9625.00	1337.00
15A	43	17.893N	070	27.207W	9625.00	1287.00
16A	43	17.866N	070	27.207W	9625.00	1237.00
17A	43	17.839N	070	27.207W	9625.00	1187.00
1B	43	18.271N	070	27.170W	9675.00	1987.00
2B	43	18.244N	070	27.170W	9675.00	1937.00
3B	43	18.217N	070	27.170W	9675.00	1887.00
4B	43	18.190N	070	27.170W	9675.00	1837.00
5B	43	18.163N	070	27.170W	9675.00	1787.00
6B	43	18.136N	070	27.170W	9675.00	1737.00
7B	43	18.109N	070	27.170W	9675.00	1687.00
8B	43	18.082N	070	27.170W	9675.00	1637.00
9B	43	18.055N	070	27.170W	9675.00	1587.00
10B	43	18.028N	070	27.170W	9675.00	1537.00
11B	43	18.001N	070	27.170W	9675.00	1487.00
12B	43	17.974N	070	27.170W	9675.00	1437.00
13B	43	17.947N	070	27.170W	9675.00	1387.00
14B	43	17.920N	070	27.170W	9675.00	1337.00
15B	43	17.893N	070	27.170W	9675.00	1287.00
16B	43	17.866N	070	27.170W	9675.00	1237.00
17B	43	17.839N	070	27.170W	9675.00	1187.00
1C	43	18.271N	070	27.133W	9725.00	1987.00
2C	43	18.244N	070	27.133W	9725.00	1937.00
3C	43	18.217N	070	27.133W	9725.00	1887.00
4C	43	18.190N	070	27.133W	9725.00	1837.00
5C	43	18.163N	070	27.133W	9725.00	1787.00
6C	43	18.136N	070	27.133W	9725.00	1737.00
7C	43	18.109N	070	27.133W	9725.00	1687.00
8C	43	18.082N	070	27.133W	9725.00	1637.00
9C	43	18.055N	070	27.133W	9725.00	1587.00
10C	43	18.028N	070	27.133W	9725.00	1537.00
11C	43	18.001N	070	27.133W	9725.00	1487.00
12C	43	17.974N	070	27.133W	9725.00	1437.00
13C	43	17.947N	070	27.133W	9725.00	1387.00

Table IV-1-2 (Cont.)

Parameter for PARAM:CADSPEN
Page 11

140 _____	42 17.920N	070 27.133W	9725.00	1337.00
150 _____	43 17.893N	070 27.133W	9725.00	1287.00
160 _____	43 17.866N	070 27.133W	9725.00	1237.00
170 _____	43 17.839N	070 27.133W	9725.00	1187.00
DB BUOY _____	43 17.833N	070 27.204W	9625.00	1176.00
C-METERS _____	43 17.999N	070 27.417W	9327.00	1482.00
CADS REF _____	43 17.892N	070 26.152W	11051.00	1254.00

Table IV-1-3

REMOTS Stations At FADS

Parameters for FADS (REM)
Page 8

Waypoints:

1-1	42 26.984N	070 35.734W	19613.00	-6173.00
1-2	42 26.984N	070 35.551W	19663.00	-6173.00
1-3	42 26.984N	070 35.369W	20113.00	-6173.00
1-4	42 26.984N	070 35.186W	20363.00	-6173.00
1-5	42 26.984N	070 35.004W	20613.00	-6173.00
1-6	42 26.984N	070 34.821W	20863.00	-6173.00
1-7	42 26.984N	070 34.639W	21113.00	-6173.00
1-8	42 26.984N	070 34.456W	21363.00	-6173.00
1-9	42 26.984N	070 34.274W	21613.00	-6173.00
1-10	42 26.984N	070 34.091W	21863.00	-6173.00
1-11	42 26.984N	070 33.909W	22113.00	-6173.00
1-12	42 26.984N	070 33.726W	22363.00	-6173.00
1-13	42 26.984N	070 33.544W	22613.00	-6173.00
1-14	42 26.984N	070 33.361W	22863.00	-6173.00
1-15	42 26.984N	070 33.179W	23113.00	-6173.00
1-16	42 26.984N	070 32.996W	23363.00	-6173.00
1-17	42 26.984N	070 32.814W	23613.00	-6173.00
1-18	42 26.984N	070 32.631W	23863.00	-6173.00
1-19	42 26.984N	070 32.449W	24113.00	-6173.00
1-20	42 26.984N	070 32.266W	24363.00	-6173.00
2-1	42 26.849N	070 35.734W	19613.00	-6423.00
2-2	42 26.849N	070 35.551W	19663.00	-6423.00
2-3	42 26.849N	070 35.369W	20113.00	-6423.00
2-4	42 26.849N	070 35.186W	20363.00	-6423.00
2-5	42 26.849N	070 35.004W	20613.00	-6423.00
2-6	42 26.849N	070 34.821W	20863.00	-6423.00
2-7	42 26.849N	070 34.639W	21113.00	-6423.00
2-8	42 26.849N	070 34.456W	21363.00	-6423.00
2-9	42 26.849N	070 34.274W	21613.00	-6423.00
2-10	42 26.849N	070 34.091W	21863.00	-6423.00
2-11	42 26.849N	070 33.909W	22113.00	-6423.00
2-12	42 26.849N	070 33.726W	22363.00	-6423.00
2-13	42 26.849N	070 33.544W	22613.00	-6423.00
2-14	42 26.849N	070 33.361W	22863.00	-6423.00
2-15	42 26.849N	070 33.179W	23113.00	-6423.00
2-16	42 26.849N	070 32.996W	23363.00	-6423.00
2-17	42 26.849N	070 32.814W	23613.00	-6423.00
2-18	42 26.849N	070 32.631W	23863.00	-6423.00
2-19	42 26.849N	070 32.449W	24113.00	-6423.00
2-20	42 26.849N	070 32.266W	24363.00	-6423.00
3-1	42 26.714N	070 35.734W	19613.00	-6673.00
3-2	42 26.714N	070 35.551W	19663.00	-6673.00
3-3	42 26.714N	070 35.369W	20113.00	-6673.00
3-4	42 26.714N	070 35.186W	20363.00	-6673.00
3-5	42 26.714N	070 35.004W	20613.00	-6673.00
3-6	42 26.714N	070 34.821W	20863.00	-6673.00
3-7	42 26.714N	070 34.639W	21113.00	-6673.00

Table IV-1-3 (Cont.)

Parameters for FAREM:KENI
Page 9

3-8	42	26.714N	070	34.456W	21363.00	-6673.00
3-9	42	26.714N	070	34.274W	21613.00	-6673.00
3-10	42	26.714N	070	34.091W	21863.00	-6673.00
3-11	42	26.714N	070	33.909W	22113.00	-6673.00
3-12	42	26.714N	070	33.726W	22363.00	-6673.00
3-13	42	26.714N	070	33.544W	22613.00	-6673.00
3-14	42	26.714N	070	33.361W	22863.00	-6673.00
3-15	42	26.714N	070	33.179W	23113.00	-6673.00
3-16	42	26.714N	070	32.996W	23363.00	-6673.00
3-17	42	26.714N	070	32.814W	23613.00	-6673.00
3-18	42	26.714N	070	32.631W	23863.00	-6673.00
3-19	42	26.714N	070	32.449W	24113.00	-6673.00
3-20	42	26.714N	070	32.266W	24363.00	-6673.00
FA05 REF	42	26.500N	070	31.500W	25413.00	-8817.00

Table IV-1-3 (Cont.)

Parameters for FAFAM:REM2
Page 8

Waypoints:

4-1	42 26.578N	070 35.734W	19613.00	-6923.00
4-2	42 26.578N	070 35.551W	19853.00	-6923.00
4-3	42 26.578N	070 35.369W	20113.00	-6923.00
4-4	42 26.578N	070 35.186W	20363.00	-6923.00
4-5	42 26.578N	070 35.004W	20613.00	-6923.00
4-6	42 26.578N	070 34.821W	20863.00	-6923.00
4-7	42 26.578N	070 34.639W	21113.00	-6923.00
4-8	42 26.578N	070 34.456W	21363.00	-6923.00
4-9	42 26.578N	070 34.274W	21613.00	-6923.00
4-10	42 26.578N	070 34.091W	21863.00	-6923.00
4-11	42 26.578N	070 33.909W	22113.00	-6923.00
4-12	42 26.578N	070 33.726W	22363.00	-6923.00
4-13	42 26.578N	070 33.544W	22613.00	-6923.00
4-14	42 26.578N	070 33.361W	22863.00	-6923.00
4-15	42 26.578N	070 33.179W	23113.00	-6923.00
4-16	42 26.578N	070 32.996W	23363.00	-6923.00
4-17	42 26.578N	070 32.814W	23613.00	-6923.00
4-18	42 26.578N	070 32.631W	23863.00	-6923.00
4-19	42 26.578N	070 32.449W	24113.00	-6923.00
4-20	42 26.578N	070 32.266W	24363.00	-6923.00
5-1	42 26.443N	070 35.734W	19613.00	-7173.00
5-2	42 26.443N	070 35.551W	19853.00	-7173.00
5-3	42 26.443N	070 35.369W	20113.00	-7173.00
5-4	42 26.443N	070 35.186W	20363.00	-7173.00
5-5	42 26.443N	070 35.004W	20613.00	-7173.00
5-6	42 26.443N	070 34.821W	20863.00	-7173.00
5-7	42 26.443N	070 34.639W	21113.00	-7173.00
5-8	42 26.443N	070 34.456W	21363.00	-7173.00
5-9	42 26.443N	070 34.274W	21613.00	-7173.00
5-10	42 26.443N	070 34.091W	21863.00	-7173.00
5-11	42 26.443N	070 33.909W	22113.00	-7173.00
5-12	42 26.443N	070 33.726W	22363.00	-7173.00
5-13	42 26.443N	070 33.544W	22613.00	-7173.00
5-14	42 26.443N	070 33.361W	22863.00	-7173.00
5-15	42 26.443N	070 33.179W	23113.00	-7173.00
5-16	42 26.443N	070 32.996W	23363.00	-7173.00
5-17	42 26.443N	070 32.814W	23613.00	-7173.00
5-18	42 26.443N	070 32.631W	23863.00	-7173.00
5-19	42 26.443N	070 32.449W	24113.00	-7173.00
5-20	42 26.443N	070 32.266W	24363.00	-7173.00
6-1	42 26.308N	070 35.734W	19613.00	-7423.00
6-2	42 26.308N	070 35.551W	19853.00	-7423.00
6-3	42 26.308N	070 35.354W	20133.00	-7423.00
6-4	42 26.308N	070 35.186W	20363.00	-7423.00
6-5	42 26.308N	070 35.004W	20613.00	-7423.00
6-6	42 26.308N	070 34.821W	20863.00	-7423.00
6-7	42 26.308N	070 34.639W	21113.00	-7423.00

Table IV-1-3 (Cont.)

Parameters for PASADLRFM
Page 5

6-8	42 26.308N	070 34.458W	21363.00	-7423.00
6-9	42 26.308N	070 34.274W	21613.00	-7423.00
6-10	42 26.308N	070 34.091W	21863.00	-7423.00
6-11	42 26.308N	070 33.909W	22113.00	-7423.00
6-12	42 26.308N	070 33.726W	22363.00	-7423.00
6-13	42 26.308N	070 33.544W	22613.00	-7423.00
6-14	42 26.308N	070 33.361W	22863.00	-7423.00
6-15	42 26.308N	070 33.179W	23113.00	-7423.00
6-16	42 26.308N	070 32.996W	23363.00	-7423.00
6-17	42 26.308N	070 32.814W	23613.00	-7423.00
6-18	42 26.308N	070 32.631W	23863.00	-7423.00
6-19	42 26.308N	070 32.449W	24113.00	-7423.00
6-20	42 26.308N	070 32.266W	24363.00	-7423.00
FADE REF	42 26.500N	070 31.500W	25413.00	-8917.00

Table IV-1-3 (Cont.)

Parameters for FASANI:REM3
Page 8

Waypoints:

7-1	42 26.173N	070 35.734W	19613.00	-7673.00
7-2	42 26.173N	070 35.551W	19863.00	-7673.00
7-3	42 26.173N	070 35.369W	20113.00	-7673.00
7-4	42 26.173N	070 35.186W	20363.00	-7673.00
7-5	42 26.173N	070 35.004W	20613.00	-7673.00
7-6	42 26.173N	070 34.821W	20863.00	-7673.00
7-7	42 26.173N	070 34.639W	21113.00	-7673.00
7-8	42 26.173N	070 34.456W	21363.00	-7673.00
7-9	42 26.173N	070 34.274W	21613.00	-7673.00
7-10	42 26.173N	070 34.091W	21863.00	-7673.00
7-11	42 26.173N	070 33.909W	22113.00	-7673.00
7-12	42 26.173N	070 33.726W	22363.00	-7673.00
7-13	42 26.173N	070 33.544W	22613.00	-7673.00
7-14	42 26.173N	070 33.361W	22863.00	-7673.00
7-15	42 26.173N	070 33.179W	23113.00	-7673.00
7-16	42 26.173N	070 32.996W	23363.00	-7673.00
7-17	42 26.173N	070 32.814W	23613.00	-7673.00
7-18	42 26.173N	070 32.631W	23863.00	-7673.00
7-19	42 26.173N	070 32.449W	24113.00	-7673.00
7-20	42 26.173N	070 32.266W	24363.00	-7673.00
8-1	42 26.038N	070 35.734W	19613.00	-7923.00
8-2	42 26.038N	070 35.551W	19863.00	-7923.00
8-3	42 26.038N	070 35.369W	20113.00	-7923.00
8-4	42 26.038N	070 35.186W	20363.00	-7923.00
8-5	42 26.038N	070 35.004W	20613.00	-7923.00
8-6	42 26.038N	070 34.821W	20863.00	-7923.00
8-7	42 26.038N	070 34.639W	21113.00	-7923.00
8-8	42 26.038N	070 34.456W	21363.00	-7923.00
8-9	42 26.038N	070 34.274W	21613.00	-7923.00
8-10	42 26.038N	070 34.091W	21863.00	-7923.00
8-11	42 26.038N	070 33.909W	22113.00	-7923.00
8-12	42 26.038N	070 33.726W	22363.00	-7923.00
8-13	42 26.038N	070 33.544W	22613.00	-7923.00
8-14	42 26.038N	070 33.361W	22863.00	-7923.00
8-15	42 26.038N	070 33.179W	23113.00	-7923.00
8-16	42 26.038N	070 32.996W	23363.00	-7923.00
8-17	42 26.038N	070 32.814W	23613.00	-7923.00
8-18	42 26.038N	070 32.631W	23863.00	-7923.00
8-19	42 26.038N	070 32.449W	24113.00	-7923.00
8-20	42 26.038N	070 32.266W	24363.00	-7923.00
9-1	42 25.903N	070 35.734W	19613.00	-8173.00
9-2	42 25.903N	070 35.551W	19863.00	-8173.00
9-3	42 25.903N	070 35.369W	20113.00	-8173.00
9-4	42 25.903N	070 35.186W	20363.00	-8173.00
9-5	42 25.903N	070 35.004W	20613.00	-8173.00
9-6	42 25.903N	070 34.821W	20863.00	-8173.00
9-7	42 25.903N	070 34.639W	21113.00	-8173.00

Table IV-1-3 (Cont.)

Parameters for PARAM:KEMO
Page 9

9-8_____	42 25.903N	070 34.456W	21363.00	-8173.00
9-9_____	42 25.903N	070 34.274W	21613.00	-8173.00
9-10_____	42 25.903N	070 34.091W	21863.00	-8173.00
9-11_____	42 25.903N	070 33.909W	22113.00	-8173.00
9-12_____	42 25.903N	070 33.726W	22363.00	-8173.00
9-13_____	42 25.903N	070 33.544W	22613.00	-8173.00
9-14_____	42 25.903N	070 33.361W	22863.00	-8173.00
9-15_____	42 25.903N	070 33.179W	23113.00	-8173.00
9-16_____	42 25.903N	070 32.996W	23363.00	-8173.00
9-17_____	42 25.903N	070 32.814W	23613.00	-8173.00
9-18_____	42 25.903N	070 32.631W	23863.00	-8173.00
9-19_____	42 25.903N	070 32.449W	24113.00	-8173.00
9-20_____	42 25.903N	070 32.266W	24363.00	-8173.00
FADS REF_____	42 25.500N	070 31.500W	25413.00	-8817.00

Table IV-1-3 (Cont.)

Parameters for PARAM:REM4

Page 8

Waypoints:

10-1	42 25.767N	070 35.734W	19813.00	-8423.00
10-2	42 25.767N	070 35.551W	19863.00	-8423.00
10-3	42 25.767N	070 35.369W	20113.00	-8423.00
10-4	42 25.767N	070 35.186W	20363.00	-8423.00
10-5	42 25.767N	070 35.004W	20613.00	-8423.01
10-6	42 25.767N	070 34.821W	20863.00	-8423.00
10-7	42 25.767N	070 34.639W	21113.00	-8423.00
10-8	42 25.767N	070 34.456W	21363.00	-8423.00
10-9	42 25.767N	070 34.274W	21613.00	-8423.00
10-10	42 25.767N	070 34.091W	21863.00	-8423.00
10-11	42 25.767N	070 33.909W	22113.00	-8423.00
10-12	42 25.767N	070 33.726W	22363.00	-8423.00
10-13	42 25.767N	070 33.544W	22613.00	-8423.00
10-14	42 25.767N	070 33.361W	22863.00	-8423.00
10-15	42 25.767N	070 33.179W	23113.00	-8423.00
10-16	42 25.767N	070 32.996W	23363.00	-8423.00
10-17	42 25.767N	070 32.814W	23613.00	-8423.00
10-18	42 25.767N	070 32.631W	23863.00	-8423.00
10-19	42 25.767N	070 32.449W	24113.00	-8423.00
10-20	42 25.767N	070 32.266W	24363.00	-8423.00
11-1	42 25.632N	070 35.734W	19813.00	-8673.00
11-2	42 25.632N	070 35.551W	19863.00	-8673.00
11-3	42 25.632N	070 35.369W	20113.00	-8673.00
11-4	42 25.632N	070 35.186W	20363.00	-8673.00
11-5	42 25.632N	070 35.004W	20613.00	-8673.00
11-6	42 25.632N	070 34.821W	20863.00	-8673.00
11-7	42 25.632N	070 34.639W	21113.00	-8673.00
11-8	42 25.632N	070 34.456W	21363.00	-8673.00
11-9	42 25.632N	070 34.274W	21613.00	-8673.00
11-10	42 25.632N	070 34.091W	21863.00	-8673.00
11-11	42 25.632N	070 33.909W	22113.00	-8673.00
11-12	42 25.632N	070 33.726W	22363.00	-8673.00
11-13	42 25.632N	070 33.544W	22613.00	-8673.00
11-14	42 25.632N	070 33.361W	22863.00	-8673.00
11-15	42 25.632N	070 33.179W	23113.00	-8673.00
11-16	42 25.632N	070 32.996W	23363.00	-8673.00
11-17	42 25.632N	070 32.814W	23613.00	-8673.00
11-18	42 25.632N	070 32.631W	23863.00	-8673.00
11-19	42 25.632N	070 32.449W	24113.00	-8673.00
11-20	42 25.632N	070 32.266W	24363.00	-8673.00
12-1	42 25.497N	070 35.734W	19813.00	-8923.00
12-2	42 25.497N	070 35.551W	19863.00	-8923.00
12-3	42 25.497N	070 35.369W	20113.00	-8923.00
12-4	42 25.497N	070 35.186W	20363.00	-8923.00
12-5	42 25.497N	070 35.004W	20613.00	-8923.00
12-6	42 25.497N	070 34.821W	20863.00	-8923.00
12-7	42 25.497N	070 34.639W	21113.00	-8923.00

Table IV-1-3 (Cont.)

Parameters for PARAM:PEM4

Page 5

12-8_____	42 25.497N	070	34.495W	21563.00	-8923.00
12-9_____	42 25.497N	070	34.274W	21613.00	-8923.00
12-10_____	42 25.497N	070	34.091W	21863.00	-8923.00
12-11_____	42 25.497N	070	33.909W	22113.00	-8923.00
12-12_____	42 25.497N	070	33.726W	22363.00	-8923.00
12-13_____	42 25.497N	070	33.544W	22613.00	-8923.00
12-14_____	42 25.497N	070	33.361W	22863.00	-8923.00
12-15_____	42 25.497N	070	33.179W	23113.00	-8923.00
12-16_____	42 25.497N	070	32.996W	23363.00	-8923.00
12-17_____	42 25.497N	070	32.814W	23613.00	-8923.00
12-18_____	42 25.497N	070	32.631W	23863.00	-8923.00
12-19_____	42 25.497N	070	32.449W	24113.00	-8923.00
12-20_____	42 25.497N	070	32.266W	24363.00	-8923.00
FADS REF_____	42 25.500N	070	31.500W	25413.00	-8917.00

Table IV-1-3 (Cont.)

Parameters for PARAM:REMS

Page 5

Waypoints:

13-1	42 25.362N	070 35.734W	19613.00	-9173.00
13-2	42 25.362N	070 35.551W	19863.00	-9173.00
13-3	42 25.362N	070 35.369W	20113.00	-9173.00
13-4	42 25.362N	070 35.186W	20363.00	-9173.00
13-5	42 25.362N	070 35.004W	20613.00	-9173.00
13-6	42 25.362N	070 34.821W	20863.00	-9173.00
13-7	42 25.362N	070 34.639W	21113.00	-9173.00
13-8	42 25.362N	070 34.456W	21363.00	-9173.00
13-9	42 25.362N	070 34.274W	21613.00	-9173.00
13-10	42 25.362N	070 34.091W	21863.00	-9173.00
13-11	42 25.362N	070 33.909W	22113.00	-9173.00
13-12	42 25.362N	070 33.726W	22363.00	-9173.00
13-13	42 25.362N	070 33.544W	22613.00	-9173.00
13-14	42 25.362N	070 33.361W	22863.00	-9173.00
13-15	42 25.362N	070 33.179W	23113.00	-9173.00
13-16	42 25.362N	070 32.996W	23363.00	-9173.00
13-17	42 25.362N	070 32.814W	23613.00	-9173.00
13-18	42 25.362N	070 32.631W	23863.00	-9173.00
13-19	42 25.362N	070 32.449W	24113.00	-9173.00
13-20	42 25.362N	070 32.266W	24363.00	-9173.00
14-1	42 25.227N	070 35.734W	19613.00	-9423.00
14-2	42 25.227N	070 35.551W	19863.00	-9423.00
14-3	42 25.227N	070 35.369W	20113.00	-9423.00
14-4	42 25.227N	070 35.186W	20363.00	-9423.00
14-5	42 25.227N	070 35.004W	20613.00	-9423.00
14-6	42 25.227N	070 34.821W	20863.00	-9423.00
14-7	42 25.227N	070 34.639W	21113.00	-9423.00
14-8	42 25.227N	070 34.456W	21363.00	-9423.00
14-9	42 25.227N	070 34.274W	21613.00	-9423.00
14-10	42 25.227N	070 34.091W	21863.00	-9423.00
14-11	42 25.227N	070 33.909W	22113.00	-9423.00
14-12	42 25.227N	070 33.726W	22363.00	-9423.00
14-13	42 25.227N	070 33.544W	22613.00	-9423.00
14-14	42 25.227N	070 33.361W	22863.00	-9423.00
14-15	42 25.227N	070 33.179W	23113.00	-9423.00
14-16	42 25.227N	070 32.996W	23363.00	-9423.00
14-17	42 25.227N	070 32.814W	23613.00	-9423.00
14-18	42 25.227N	070 32.631W	23863.00	-9423.00
14-19	42 25.227N	070 32.449W	24113.00	-9423.00
14-20	42 25.227N	070 32.266W	24363.00	-9423.00
15-1	42 25.091N	070 35.734W	19613.00	-9673.00
15-2	42 25.091N	070 35.551W	19863.00	-9673.00
15-3	42 25.091N	070 35.369W	20113.00	-9673.00
15-4	42 25.091N	070 35.186W	20363.00	-9673.00
15-5	42 25.091N	070 35.004W	20613.00	-9673.00
15-6	42 25.091N	070 34.821W	20863.00	-9673.00
15-7	42 25.091N	070 34.639W	21113.00	-9673.00

Table IV-1-3 (Cont.)

Parameters for PARAM:REMS
Page 9

15-6	42	25.091N	070	34.455W	21363.00	-9673.00
15-9	42	25.091N	070	34.274W	21613.00	-9673.00
15-10	42	25.091N	070	34.091W	21863.00	-9673.00
15-11	42	25.091N	070	33.909W	22113.00	-9673.00
15-12	42	25.091N	070	33.726W	22363.00	-9673.00
15-13	42	25.091N	070	33.544W	22613.00	-9673.00
15-14	42	25.091N	070	33.361W	22863.00	-9673.00
15-15	42	25.091N	070	33.179W	23113.00	-9673.00
15-16	42	25.091N	070	32.996W	23363.00	-9673.00
15-17	42	25.091N	070	32.814W	23613.00	-9673.00
15-18	42	25.091N	070	32.631W	23863.00	-9673.00
15-19	42	25.091N	070	32.449W	24113.00	-9673.00
15-20	42	25.091N	070	32.266W	24363.00	-9673.00
FADE REF	42	25.500N	070	31.500W	25412.93	-9517.55

Table IV-1-3 (Cont.)

Parameters for PARAM:REMS
Page 6

Waypoints:

16-1	42 24.956N	070 35.734W	19613.00	-9923.00
16-2	42 24.956N	070 35.551W	19863.00	-9923.00
16-3	42 24.956N	070 35.369W	20113.00	-9923.00
16-4	42 24.956N	070 35.186W	20363.00	-9923.00
16-5	42 24.956N	070 35.004W	20613.00	-9923.00
16-6	42 24.956N	070 34.821W	20863.00	-9923.00
16-7	42 24.956N	070 34.639W	21113.00	-9923.00
16-8	42 24.956N	070 34.456W	21363.00	-9923.00
16-9	42 24.956N	070 34.274W	21613.00	-9923.00
16-10	42 24.956N	070 34.091W	21863.00	-9923.00
16-11	42 24.956N	070 33.909W	22113.00	-9923.00
16-12	42 24.956N	070 33.726W	22363.00	-9923.00
16-13	42 24.956N	070 33.544W	22613.00	-9923.00
16-14	42 24.956N	070 33.361W	22863.00	-9923.00
16-15	42 24.956N	070 33.179W	23113.00	-9923.00
16-16	42 24.956N	070 32.996W	23363.00	-9923.00
16-17	42 24.956N	070 32.814W	23613.00	-9923.00
16-18	42 24.956N	070 32.631W	23863.00	-9923.00
16-19	42 24.956N	070 32.449W	24113.00	-9923.00
16-20	42 24.956N	070 32.266W	24363.00	-9923.00
17-1	42 24.821N	070 35.734W	19613.00	-10173.00
17-2	42 24.821N	070 35.551W	19863.00	-10173.00
17-3	42 24.821N	070 35.369W	20113.00	-10173.00
17-4	42 24.821N	070 35.186W	20363.00	-10173.00
17-5	42 24.821N	070 35.004W	20613.00	-10173.00
17-6	42 24.821N	070 34.821W	20863.00	-10173.00
17-7	42 24.821N	070 34.639W	21113.00	-10173.00
17-8	42 24.821N	070 34.456W	21363.00	-10173.00
17-9	42 24.821N	070 34.274W	21613.00	-10173.00
17-10	42 24.821N	070 34.091W	21863.00	-10173.00
17-11	42 24.821N	070 33.909W	22113.00	-10173.00
17-12	42 24.821N	070 33.726W	22363.00	-10173.00
17-13	42 24.821N	070 33.544W	22613.00	-10173.00
17-14	42 24.821N	070 33.361W	22863.00	-10173.00
17-15	42 24.821N	070 33.179W	23113.00	-10173.00
17-16	42 24.821N	070 32.996W	23363.00	-10173.00
17-17	42 24.821N	070 32.814W	23613.00	-10173.00
17-18	42 24.821N	070 32.631W	23863.00	-10173.00
17-19	42 24.821N	070 32.449W	24113.00	-10173.00
17-20	42 24.821N	070 32.266W	24363.00	-10173.00
18-1	42 24.686N	070 35.734W	19613.00	-10423.00
18-2	42 24.686N	070 35.551W	19863.00	-10423.00
18-3	42 24.686N	070 35.369W	20113.00	-10423.00
18-4	42 24.686N	070 35.186W	20363.00	-10423.00
18-5	42 24.686N	070 35.004W	20613.00	-10423.00
18-6	42 24.686N	070 34.821W	20863.00	-10423.00
18-7	42 24.686N	070 34.639W	21113.00	-10423.00

Table IV-1-3 (Cont.)

Parameters for PARAM:REM6

Page 5

18-6_____	42	24.686N	070	34.458W	21363.00	-10423.00
18-9_____	42	24.686N	070	34.274W	21613.00	-10423.00
18-10_____	42	24.686N	070	34.091W	21863.00	-10423.00
18-11_____	42	24.686N	070	33.909W	22113.00	-10423.00
18-12_____	42	24.686N	070	33.725W	22363.00	-10423.00
18-13_____	42	24.686N	070	33.544W	22613.00	-10423.00
18-14_____	42	24.686N	070	33.361W	22863.00	-10423.00
18-15_____	42	24.686N	070	33.179W	23113.00	-10423.00
18-16_____	42	24.686N	070	32.996W	23363.00	-10423.00
18-17_____	42	24.686N	070	32.814W	23613.00	-10423.00
18-18_____	42	24.686N	070	32.631W	23863.00	-10423.00
18-19_____	42	24.686N	070	32.449W	24113.00	-10423.00
18-20_____	42	24.686N	070	32.266W	24363.00	-10423.00
FADS REF_____	42	25.500N	070	31.500W	25413.00	-8917.00

Table IV-1-3 (Cont.)

Parameters for PARAM:REM7

Page 2

Waypoints:

19-1	42 24.550N	070 35.734W	19613.00	-10673.00
19-2	42 24.550N	070 35.551W	19663.00	-10673.00
19-3	42 24.550N	070 35.369W	20113.00	-10673.00
19-4	42 24.550N	070 35.186W	20363.00	-10673.00
19-5	42 24.550N	070 35.004W	20613.00	-10673.00
19-6	42 24.550N	070 34.821W	20863.00	-10673.00
19-7	42 24.550N	070 34.639W	21113.00	-10673.00
19-8	42 24.550N	070 34.456W	21363.00	-10673.00
19-9	42 24.550N	070 34.274W	21613.00	-10673.00
19-10	42 24.550N	070 34.091W	21863.00	-10673.00
19-11	42 24.550N	070 33.909W	22113.00	-10673.00
19-12	42 24.550N	070 33.726W	22363.00	-10673.00
19-13	42 24.550N	070 33.544W	22613.00	-10673.00
19-14	42 24.550N	070 33.361W	22863.00	-10673.00
19-15	42 24.550N	070 33.179W	23113.00	-10673.00
19-16	42 24.550N	070 32.996W	23363.00	-10673.00
19-17	42 24.550N	070 32.814W	23613.00	-10673.00
19-18	42 24.550N	070 32.631W	23863.00	-10673.00
19-19	42 24.550N	070 32.449W	24113.00	-10673.00
19-20	42 24.550N	070 32.266W	24363.00	-10673.00
20-1	42 24.415N	070 35.734W	19613.00	-10923.00
20-2	42 24.415N	070 35.551W	19663.00	-10923.00
20-3	42 24.415N	070 35.369W	20113.00	-10923.00
20-4	42 24.415N	070 35.186W	20363.00	-10923.00
20-5	42 24.415N	070 35.004W	20613.00	-10923.00
20-6	42 24.415N	070 34.821W	20863.00	-10923.00
20-7	42 24.415N	070 34.639W	21113.00	-10923.00
20-8	42 24.415N	070 34.456W	21363.00	-10923.00
20-9	42 24.415N	070 34.274W	21613.00	-10923.00
20-10	42 24.415N	070 34.091W	21863.00	-10923.00
20-11	42 24.415N	070 33.909W	22113.00	-10923.00
20-12	42 24.415N	070 33.726W	22363.00	-10923.00
20-13	42 24.415N	070 33.544W	22613.00	-10923.00
20-14	42 24.415N	070 33.361W	22863.00	-10923.00
20-15	42 24.415N	070 33.179W	23113.00	-10923.00
20-16	42 24.415N	070 32.996W	23363.00	-10923.00
20-17	42 24.415N	070 32.814W	23613.00	-10923.00
20-18	42 24.415N	070 32.631W	23863.00	-10923.00
20-19	42 24.415N	070 32.449W	24113.00	-10923.00
20-20	42 24.415N	070 32.266W	24363.00	-10923.00
FADS REF	42 25.500N	070 31.500W	25413.00	-8917.00

mode and range with actual sieve analysis of samples has shown that this "approximate" technique is accurate.

Other than the above grain-size estimates, all other measurements or observations are made from negatives by means of computer image analysis. The negatives are placed on a light table and the back-lighted negative is imaged with a high-resolution zoom lens video camera. The video signal is input into an analog-digital converter. This system has a 256 grey-scale resolution. Grey-scale density slicing with such a system should allow for rapid manual editing (adding or deleting pixels) depending on the operator's judgement.

An electronic data sheet is presented to the operator via the computer screen. This allows for a consistent and efficient measurement routine. Measurements are made from the images by overlaying movable x-y cursor lines which are displayed on the computer screen (linear measurements), or by grey-scale density slicing (area measurements). As measurements are made, they are recorded on disc according to project name, date, time, station number, and film frame number. These data can then be printed out on hard copy data sheets or data subsets can be compiled for subsequent statistical tests, graphing, or sent to an x-y plotter for contour mapping.

The analysis step is the most time consuming and so the analytical system and its software are of paramount importance for cost-effectiveness. While several computer image analysis systems are available, SAIC has found the Measurionics Inc. Explorer II System to be very efficient for the above measurement routine. The software should allow the operator to completely measure a negative within 3 minutes.

1.4 Mapping

The kinds of data to be mapped depend on project goals. For projects involving the disposal of dredged materials, the following data sets are either mapped or presented as histograms:

- 1.) Dredged material thickness at the disposal site (Figure IV-1-1). In order to make mass balance calculations, i.e. compare the volumes of dredged material or capping material with that mapped at the disposal site, one must have an accurate means of mapping dredged material thickness. For those parts of the deposit that are thicker than 20 cm, precision acoustic bathymetry is used. For those parts of the deposit less than 20 cm thick, but greater than 0.1 cm thick, sediment profile imaging is the most accurate. This optical technique is based on using the grey-scale contrast of the buried pre-disposal surface as a datum for measuring the thickness of overlying (different grey-scale contrast or different grain-size) disposed material. This technique can be used for up to one year following disposal as the grey-scale contrast persists for this time period (Germano, 1983).

12/84

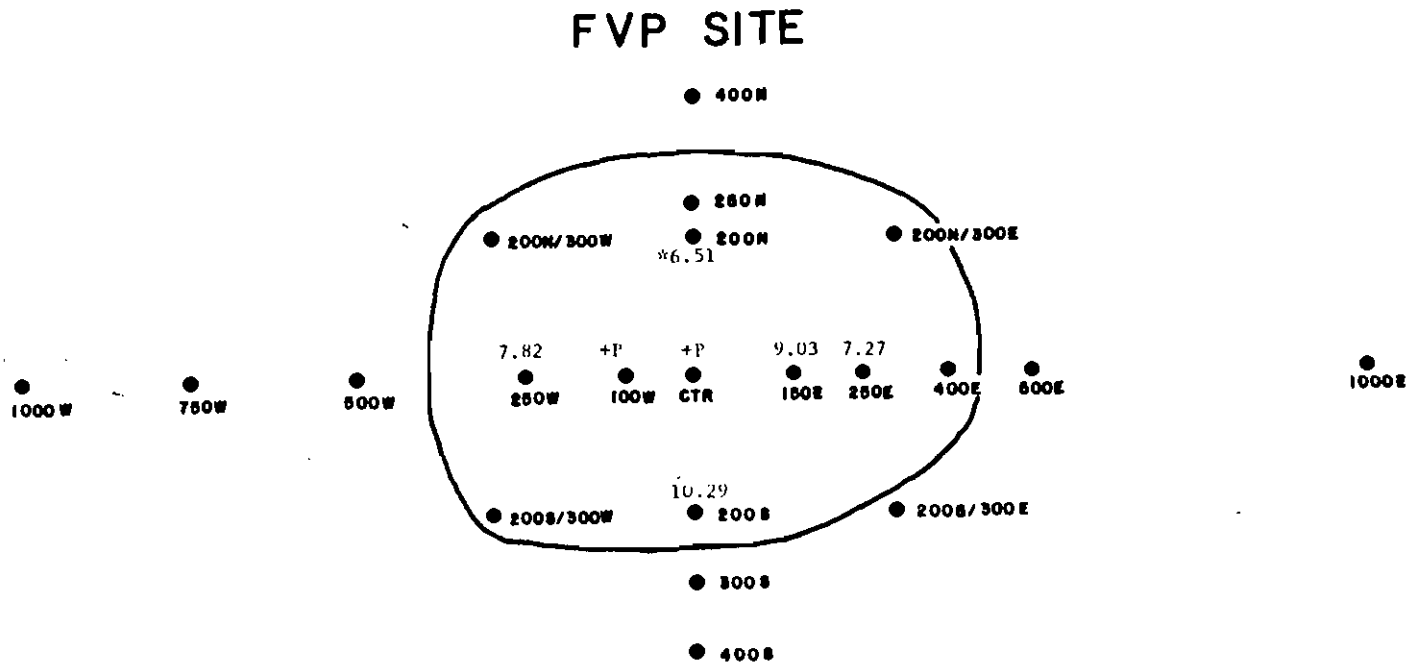

Figure IV-1-1. The apparent distribution and thickness (cm) of dredged material, averaged by station, at the FVP site in December 1984. The solid line encloses the twelve stations considered to be on the main dredged material mound or flanks.

P+ = Dredged material thicker than REMOTS® window penetration.

* = Dredged material not observed in all replicate images from that station.

2.) The depth of the apparent RPD (Figure IV-1-2) in sediments is contoured. This redox depth is controlled both by molecular diffusion and biological advection of aerobic water into the bottom. Time-series (eg. monthly) contouring of such data can provide spatial information about the rate of colonization (biogenic pumping) and chemical diagenesis of the deposited materials related to changing pore water Eh. While there are a number of complex interactions involved in this oxidation process, anomalously slow rates of downward migration of the apparent redox have been used to identify parts of disposal sites which require more intensive monitoring as to the causes for the observed anomaly.

3.) Boundary roughness or small scale sediment surface relief is commonly presented as frequency distributions with different histograms presented for each sampling period or histograms are compared between on-site versus off-site (control) areas. Past experience has shown that patterns of boundary roughness in muds are related to animal-sediment interactions (i.e. biogenic topography). Mapping of such data can be useful in assessing time-space gradients in infaunal activity following a seafloor disturbance.

4.) If the disposed material, or capping material, is different in its textural qualities from the ambient sediment, grain-size mapping is done to compliment the dredged material thickness contour maps.

5.) An Organism-Sediment Index is commonly mapped (Figure IV-1-3) and presented as a histogram (Figure IV-1-4) in order to document the colonization rate of disposal sites. This index involves three factors: The mean depth of the apparent RPD, the presence or absence of imaged methane gas voids, and the successional status of the bottom as deduced from profile images. The index has a potential range of -10 to +11. A minus ten value represents an azoic methanogenic sediment without an apparent redox boundary (poor habitat quality). A plus 11 represents a deeply ventilated sediment occupied by a high-order successional stage (high habitat quality). Criteria for calculating this index are given in Rhoads and Germano, 1982 and Germano and Rhoads, 1984. Histograms of organism-sediment indices, with appropriate non-parametric tests, have been found to be useful for quantifying change in disposal site conditions relative to either baseline conditions or post-disposal ambient seafloor conditions. These rapidly obtained data have also proven useful in laying out a cost-effective faunal grab-sampling program.

6.) Finally, any residual sediment-profile data that can contribute to an understanding of benthic processes is mapped. Such "process maps" commonly contain information about erosional areas (mud clasts, physical boundary roughness, bedforms, shell-lag deposits or depositional areas (RDSI's), or hypoxic areas (as determined by a thin or non-existent apparent RPD).

FVP SITE

12/84

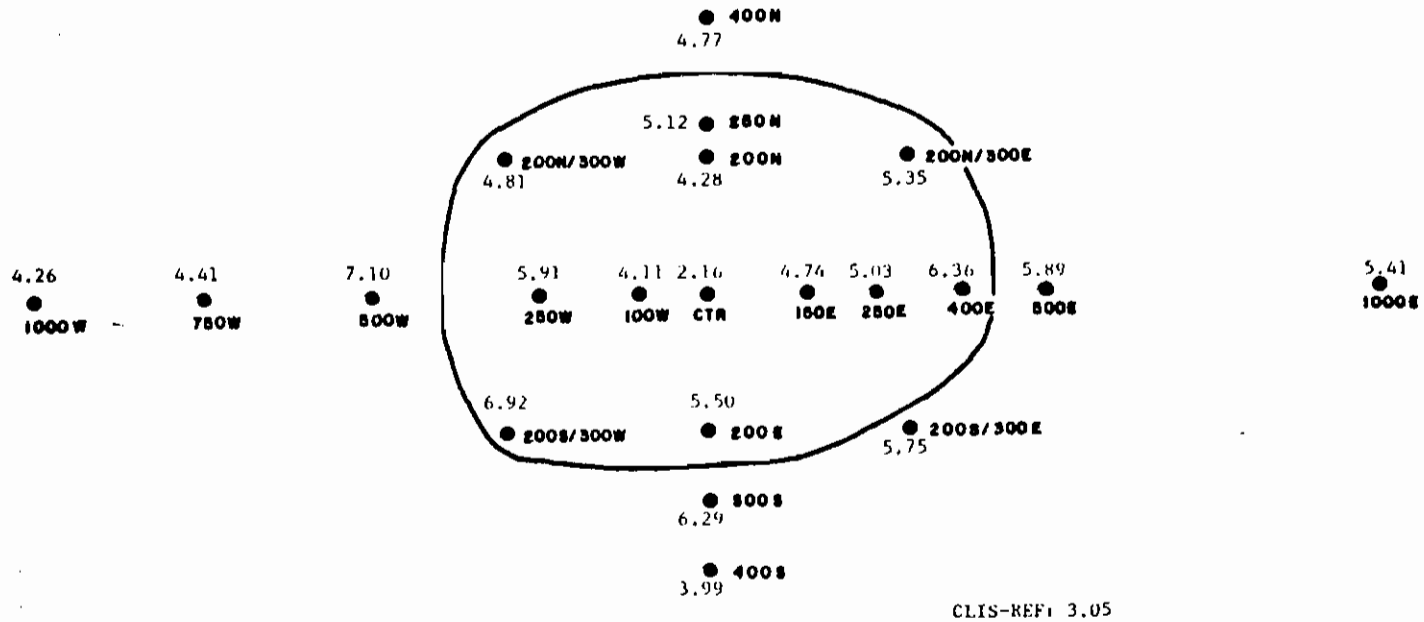
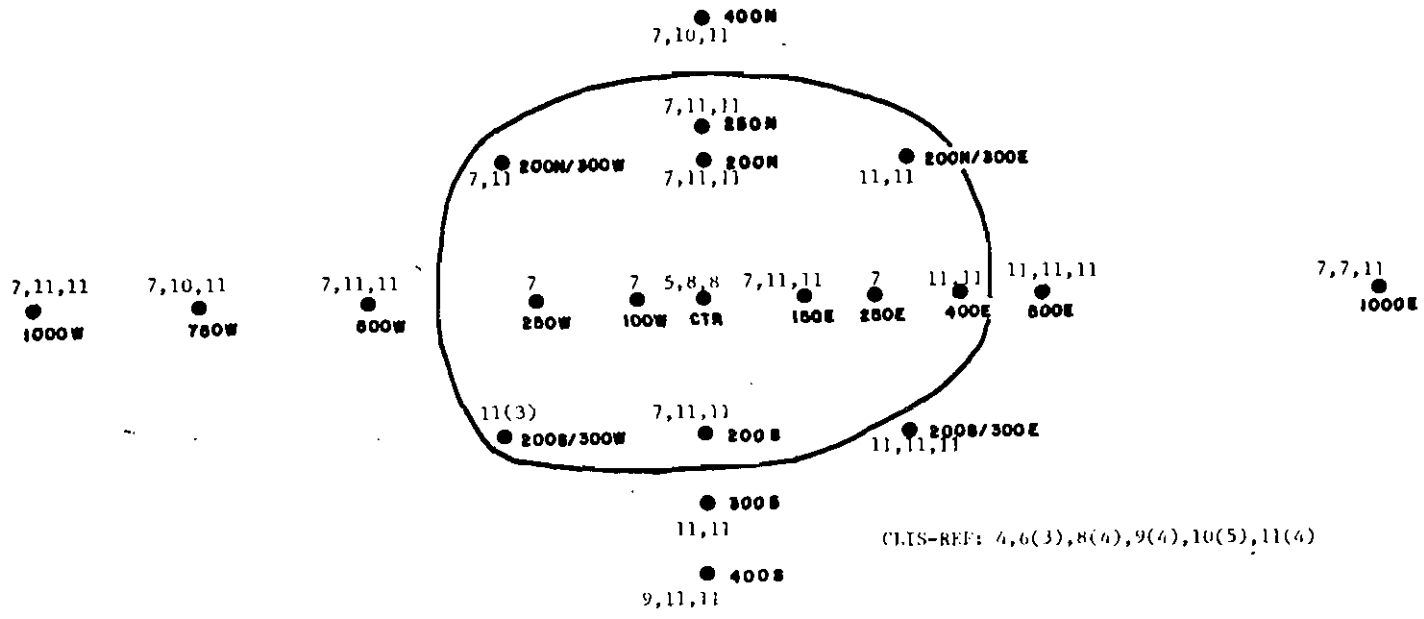

Figure IV-1-2. Mapped average RPD values at each station.

FVP SITE



IV-24

Figure IV-1-3. Mapped distribution of benthic indices for all replicates in the December survey.

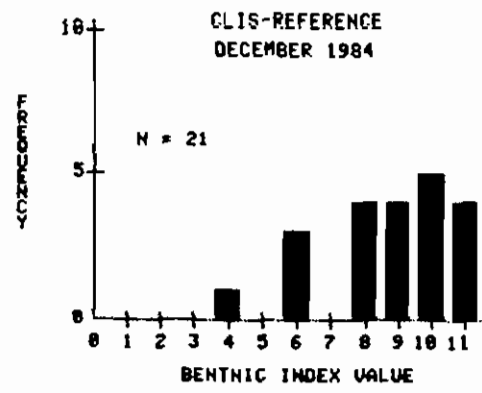
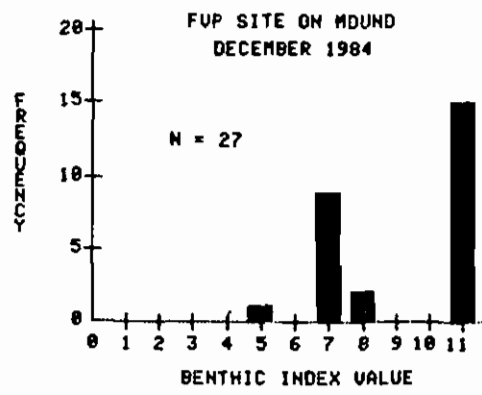
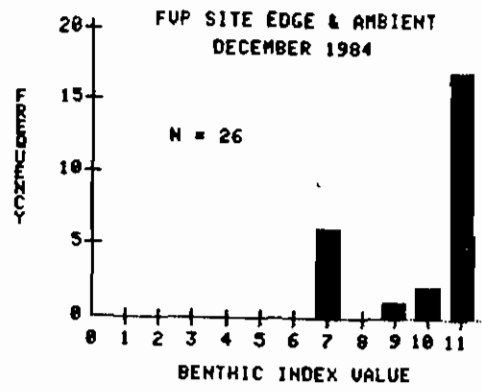

Figure IV-1-4. Benthic index frequency distributions for the edge and ambient, on mound, and CLIS-REF stations.



2.0 SEDIMENT TRANSPORT INVESTIGATIONS

2.1 Objectives

Determinations of the character of the local sediment transport system represents an essential element within the management of both dredging and dredged material disposal operations. These operations have the potential to affect this transport both indirectly through modification of the ambient flow field and directly by the introduction of sediments into the water column via mechanical agitation, barge overflow or discharge, and/or surface erosion of the placed mound of dredged materials. These sediment displacements, in turn, can influence ambient water quality, the exposure of local biota to sediment associated contaminants (both organic and inorganic), and a variety of engineering characteristics affecting the stability of the dredged channel and placed materials and the ultimate utility of the disposal site.

The majority of sediment dredged in New England consists of relatively fine grained sands, silts and clays. On displacement these materials are typically transported in suspension with the fraction moving in close contact with the sediment-water interface as bed-load representing a small to insignificant portion of the total transport. The quantity and character of the materials transported in suspension are governed by a variety of factors including local tidal regime, fresh water streamflows, surface wind wave characteristics, seasonal biological effects, sediment properties including grain size and composition, and inflows from the adjacent continental shelf. Typically this combination of factors produces a suspended material field characterized by a high degree of spatial and temporal variability. Within this system maximum resuspension and transport typically occurs during relatively short-lived, high energy, storm events. The unpredictable, aperiodic, nature of these events in combination with their intensity complicates system sampling and in general, limits the utility of survey schemes employing standard shipboard sampling techniques. Under these conditions accurate detailing of the characteristics of the suspended material field sufficient to permit quantitative evaluation of system response to short-term perturbations such as storms or dredging related activities requires the use of more nearly continuous, in situ, sampling systems. Such systems have been developed for use within the ongoing DAMOS program and at present represent the essential element within the standard sampling protocol used in the evaluation of the sediment transport dynamics affecting active dredge materials disposal areas.

2.2 Instrumentation Characteristics

Evaluations of sediment transport system dynamics with particular emphasis on the suspended material field in the area adjacent to selected dredged material disposal sites are based on the variety of data provided by a specially designed, bottom-mounted, instrumentation array (DAISY) in combination with

observations of regional bathymetry, sediment properties on and adjacent to the disposal site, diver and submersible surveys, and discrete samples of water column characteristics including temperature, salinity, and suspended material concentrations. These data are supplemented by regional meteorological observations obtained at reasonably proximate shore stations. The specifications applicable to these data sets including instrument design criteria are discussed below.

In designing the instrumentation array it was determined that in order to provide the required observations, with particular emphasis on the ability to reliably monitor conditions during aperiodic storm events, the array should be bottom-mounted and self-contained with sufficient integral power and data recording capability to permit reasonable long-term (30 days) in-situ deployments. The support frame was to be configured so as to minimize flow disturbance and the potential for snagging fish trawls or other similar itinerant commercial fishing operations while providing rugged support and ease of handling from relatively small vessels operating in a range of sea-states. In addition, the frame was to provide mounting arrangements that could be easily modified to accommodate a variety of instruments and/or instrument systems. Overall the array was to be capable of either stand-alone operation or supplementary operation as part of a larger system or array of systems.

The components contained in the basic array configuration have the following characteristics:

2.2.1 Temperature Sensor

The basic array contains two solid state sensors to monitor water temperature. These instruments are distributed over the vertical to provide a measure of both ambient temperatures and any associated vertical gradient. The upper sensor is located approximately 2.5 m above the sediment-water interface with the lower sensor approximately 0.5 m above the interface. Both sensors are cable connected to an electronics network contained within the data logger. This arrangement is easily maintained in the field and displays minimal potential for long term data loss due to sensor flooding.

The temperature system provides an analog voltage output proportional to water temperature. Specified system accuracy is $\pm 0.25^{\circ}$ C. System output characteristics for specified ranges of water temperature is determined by laboratory calibration against certified standards. During long-term deployments of the instrumentation array, the temperature system is recalibrated at least once every three months. During shorter term deployment the system is calibrated prior to deployment and recalibrated on recovery.

2.2.2 Conductivity

The basic array contains a single sensor monitoring the conductivity of the near-bottom waters at a point approximately 1.5 m above the sediment-water interface. This sensor consists of a three-electrode flow-through cell which produces a frequency output proportional to conductivity (Sea-Bird Model 4-01). Frequency counting and subsequent conversion for data recording purposes is provided by circuitry housed within the data-logger. This system was selected in lieu of the more common analog electrode systems to minimize systems sensitivity to bio-fouling and/or electrode polarization. This insensitivity is essential to reliable long-term observations.

The conductivity system in use on the array is temperature compensated and displays a long term accuracy in excess of 0.01 mmho/cm with 30 day stability greater than 0.003 mmho/cm. Warmup time is less than 2 sec with response to changing conductivity levels registered in less than 5 sec. Response time can be significantly improved if mechanical flushing is provided for the flow-through cell. For the purposes of the initial field deployments such flushing was not considered essential.

The conversion of frequency counts to equivalent conductivity is accomplished using an algorithm provided by the sensor manufacturer. The accuracy of this conversion is checked periodically by intercomparisons against laboratory run samples calibrated using Copenhagen Standard Water or equivalent (I.A.P.S.O. Standard Sea-Water).

2.2.3 Current Meter

Near-bottom flow conditions are monitored using a single two-axis electromagnetic current meter positioned approximately 1.0 m above the sediment-water interface. The x-y axis of this system is coincident with the horizontal and is fixed in orientation with respect to magnetic north. This system and its associated electronics provides an analog voltage output proportional to flow speed. Voltage levels for each component are sensed and recorded by the data logger. During the data analysis phase software routines convert these values into equivalent flow speed and direction.

The current meter system selected for use in the array (Marsh-McBirney Model 585 OEM) displays a response time of 0.5 sec over a flow range of +/- 300 cm/sec. Stated long-term drift is less than 2 cm/sec and accuracy exceeds +/- 2% of an individual reading. This system is recalibrated annually using a recirculating water tunnel in combination with laboratory standard flowmeters (heated sensors, laser doppler, or equivalent).

2.2.4 Nephelometers/Transmissometers

The near-bottom concentration of suspended materials is monitored using two optical transmissometers mounted on adjacent legs of the array frame and positioned to sense conditions at points located approximately 1.0 m above the sediment-water interface. This redundancy is recommended for reliability. Designed to be relatively insensitive to dissolved materials (particularly color-rich organics) these units provide an indirect measure of suspended material concentrations by monitoring the attenuation of light produced by narrow beam red-light emitters (LED) and projected over a finite pathlength. Selected pathlength varies as a function of suspended material concentrations. For the majority of inshore sites a 10 cm pathlength has been found to be sufficient. Within system adjustment of the pathlength is provided to accommodate higher or lower concentration conditions.

Each transmissometer provides an analog voltage output that is proportional to beam attenuation. Conversion to equivalent suspended material concentrations is accomplished using algorithms developed by calibrating each sensor against laboratory standards. Standards are prepared by suspending varying concentrations of sediment, obtained from the sediment-water interface adjacent to the deployment site, in a test chamber housing the transmissometer. The resultant sensor output, observed at a minimum of 10 concentrations distributed over the range expected at the field site, is used to develop the conversion algorithm. Instruments are calibrated monthly at a minimum and before and after each short-term deployment. This recalibration sequence is required to maintain desired system accuracy of +/- 0.5 mg/l in the estimation of suspended material concentrations.

2.2.5 Sequenced Water Sampler

Direct samples of water can be periodically obtained from the area adjacent to the instrumentation array using a mechanical water sampler attached to the frame. This system allows estimation of drift and the effects of bio-fouling on the optical sensors by providing discrete samples sufficient to yield a direct measure of suspended material concentrations and associated water column conductivity. Sampling is accomplished using a series of 12 0.7 liter, syringe-like ports. Each port is spring loaded and armed by means of a burn-wire strap. Sample sequencing is controlled by a simple counting network or a micro-processor based controller sufficient to permit conditional sampling. The counting network is used to obtain periodic conditional sampling. The counting network is used to obtain periodic samples and serves simply to activate current flow to rupture the burn-wire after the receipt of a pre-determined number of counts. The micro-processors based controller is used to initiate sampling after a specified suspended material concentration level, indicated by the transmissometer output, or threshold flow velocity, keyed to the output from the current meter, is exceeded. The system and associated scheme to be used varies in response to the purpose of the particular array

deployment.

2.2.6 Lapsed Time Camera and Strobe

A visual indication of conditions prevailing during each sampling sequence is provided by a lapsed time camera system and associated strobe light. This combination is directed towards the sediment-water interface and provides an indication of the conditions of the bottom and the effects of sediment resuspension on the intervening water column. In addition, these photographs provide indication of the presence or absence of detrital debris that may affect the operation of the current sensors as well as the optical transmissometers.

The lapsed time camera consists of a super 8mm gun camera with a film cassette sufficient to provide approximately 3000 frames. System triggering is activated by pulses provided by the data logger. In normal operation one frame is exposed during each period of array sampling. As designed, each frame should contain time, date and deployment information as well as providing indication of frame orientation relative to magnetic north.

2.2.7 Wave Gauge

The presence or absence of surface wave-induced flows in the near-bottom area is sensed using a pressure sensitive recording wave gauge. This gauge (Sea-Data Model 635-11) employs a Paros Scientific Digi-Quartz transducer to sense pressure variations induced by surface wind waves and the astronomical tide. System resolution exceeds 0.1 cm for both wave and tidal amplitude with accuracies on the order of 0.4 cm in water depths ranging up to 25 cm (80 ft.). System stability is essentially constant over one month periods equalling approximately 0.0002% of full scale/month.

The output from the pressure transducer is, following conditioning, sampled at a specified rate and the result is stored digitally on magnetic tape using a recorder housed within the wave gauge. This "burst sampling" system can be switch programmed to provide samples on intervals ranging from once each half hour out to one per day. For each sampling period both sampling frequency and the number of samples can be specified. Sampling frequency can range from one sample every half second out to one sample each 16 seconds. The number of samples can be specified over a range of 64 to 2048 samples/burst. In addition to this sequenced sampling a continuous sampling mode is also available providing an 8.5 day record of near-bottom wave pressure conditions sampled at a one second rate.

For the majority of applications, the wave gauge functions in a stand-alone mode and no attempt is made to share a common time base with the data logger used by the instrumentation array. Initialization times used to note the beginning of each recording have been found to provide a reasonable basis for the intercomparison of wave data and outputs from the variety of

array instruments. Despite this operational procedure common time base sharing can be easily implemented with the present systems if future demands require.

2.2.8 Data Logger

The analog outputs from the optical transmissometers, the current meter, water temperature and conductivity sensors are sampled and recorded using a bursting digital data logger (Sea Data Model 651-8). In addition this unit serves as a partial power supply for selected array components and provides logic control for all array elements with the exception of the wave gauge. Logic control includes system turn on-turn off commands and sequenced pulses to activate the lapsed time camera system and the mechanical water sampler. This system also has the potential for the incorporation of a micro-processor based unit sufficient to permit conditional sampling.

The system data logger digitizes and records up to 8 analog inputs with 12 bit accuracy. All data are recorded digitally on a magnetic tape cassette with a capacity of approximately 15 million bits (450 ft. tape). This burst sampling system can be switch programmed to provide a variety of sampling intervals and associated record lengths. The specifications of this system are essentially similar to that used in the wave gauge and are summarized in Table IV-2-1.

The standard sampling routine used in all long-term array deployments to date calls for burst sampling and/or triggering of all array components every 15 minutes. During each of these sampling intervals the lapsed time camera and strobe is triggered once, a pulse is passed for counting to the water sampler electronics, and each of the analog input channels is scanned 48 times at a 2 sec/scan rate. This routine allows a deployment period of approximately 35 days before the capacity of the magnetic tape cassette is exceeded.

The wave gauge represents the single array component not included in the above sampling routine. Functioning as a stand alone unit, the wave gauge is typically burst sampled at a rate of once each hour for a period of approximately 8.5 min. During this interval 1024 samples of near bottom pressure are obtained at a 0.5 sec rate. This scheme serves to fill available data storage capacity in approximately 35 days requiring servicing of the wave gauge at the same frequency as the other array components.

As noted, both the wave gauge and the array data loggers permit establishment of a variety of sampling schemes. This flexibility represents an essential element within any instrumentation system intended for the study of a variety of sediment transport problems within coastal areas characterized by a high degree of spatial and temporal variability. Future system designs must continue to place particular emphasis on this characteristic.

TABLE IV-2-1

Model 651-8 DETAILED SPECIFICATIONS

MEASUREMENT RATE

Scan Interval: 0.5 sec to 16 sec in 6 steps
 Channel Scan Rate: 700 psec per channel (independent of scan interval).

ANALOG DATA INPUTS

Channels: 8 single-ended analog (optional: 8 differential).
 Resolution: Each channel is converted to a 12-bit binary word.
 Input range: -5 to +5 volts standard. Other ranges optional.
 Input resolution: 0.0025 volts (0.0012 volts on 0 to 5 volt range).
 Connectors: Terminal strip, or D-subminiature connector in rack for user-wired endcap penetrators (optionally supplied).

THERMOMETER

Built in, selectable with backplane wiring.
 Accuracy: $\pm 0.2^{\circ}$ C over range -15° C to $+75^{\circ}$ C.
 Option: -5° C to $+35^{\circ}$ C range available, accurate to 0.1° C.

DATA PROGRAMMING

Interval: 1/8, 1/4, 1/2, 1, 2, 4 hours.
 Burst Rate: 0.5, 1, 2, 4, 8, 16 seconds.
 Burst Duration: 24, 48, 72, 96, 120, 144, 168, 192, 216, 240, 264 scans.
 Channels: 1, 2, 3, 4, 6, 8.

DATA STORAGE

Medium: Standard digital certified 300' or 450' cassette tapes.
 Tape Format: 800 bpi phase-encoded on 4 tracks
 Capacity: 10 megabits on 300' cassette yielding 785,000 words 12 bit data words, plus 49,000 24-bit header-time words on 300' tape.
 Data Format: 4 bits showing channels switch setting on front panel 20-bit binary time word
 1 to 8 analog 12-bit data channels, repeated to total 24 words.
 4 parity bits (one for each track).

TIMEBASE

16.384 kHz quartz crystal
 Accuracy: Stable to ± 10 ppm over 10° C to 40° C.
 Correctable to ± 5 ppm over -5° C to $+55^{\circ}$ C.

Table IV-2-1 (Cont.)

POWER	SBD-3 Sea Data 15 volt 40 Ahr Alkaline battery pak.
RACK	
Size:	27" long by 5.8" diameter.
Weight:	10 pounds including Alkaline SBD-4 battery.
PRESSURE CASE	
Material:	6061-T6 Aluminum.
Hardware:	316 STainless with Delrin insulators.
Finish:	Sanford hard-coat anodize with polyurathane paint
Size:	6.75" diameter by 29' long.

2.3 Field Procedures

2.3.1 Array Recovery

As normally deployed the instrumentation array is simply bottom mounted with no visible surface markings or floats. This configuration is intended to minimize the potential for vandalism or array upset due to snagging of the surface float by passing vessels or barges. Array location is simply marked by LORAN C coordinates recorded as the array touches bottom on deployment. LORAN positioning is supplemented by a series of acoustic beacons mounted on the array frame. These beacons can be echo located using a hand-held hydrophone from shipboard or by divers swimming a search pattern. The acoustic beacons are supplemented by an acoustically activated release tethered to the array and buoyed a short distance above it. A line cannister is attached to the release which, following activation, allows the release to float upward streaming a tether line. Under normal circumstances it is this tether line that is used to locate the array and to allow divers to attach a more substantive retrieval line. The acoustic beacons provide a useful backup in the event of a malfunction of the acoustic release due to electronic failure, severe bio-fouling, or array upset or entanglement by fishing nets. These beacons are considered to be an essential part of the instrumentation array.

2.3.2 Supplementary "Hydrographic" Surveying

Each deployment of the instrumentation array as part of the DAMOS program is routinely supplemented by a variety of complementary surveys intended to detail the physical, geological, and biological characteristics of the area adjacent to the deployment site. Typically these include precision bathymetric surveys, REMOTS surveys, diver surveys over shallow water sites or submersible dives at deeper sites, current meter observations over the vertical using an array of meters and taut wire moorings, and a series of routine hydrographic observations. These latter observations include drawn water sampling at a minimum of three points on the vertical (surface, mid-depth, and near-bottom) using 3 to 5 liter Niskin bottles. Sampling is conducted at a single station adjacent to the deployment site immediately following array deployment and just prior to array recovery. These drawn water samples are returned to the laboratory bridge (induction salinometer) standardized against Standard Water. Suspended material concentration is evaluated by vacuum filtration of a minimum of one liter of water through dried and preweighed membrane filters mounted in standard Millipore filtration setups (47 mm Nuclepore 0.45 μ m pore size). Associated water temperature for each sample is determined using thermistor temperature probes at the time of shipboard recovery. These hydrographic observations are intended to directly complement the array observations and represents an important component within system calibration and data verification.

To supplement this variety of oceanographic observations, meteorological data is obtained from shore stations proximate to the deployment site. The utility of these data varies primarily as a function of the distance between the meteorological station and the array site. Secondary factors include the topographic characteristics of the lands surrounding the station and any evident structural sheltering. For the New England area the separation of the meteorological and survey sites should be no greater than 10 -15 nm. Beyond this range the spatial variability inherent in the local weather systems becomes a factor and measurable differences in conditions become evident. In addition, the meteorological stations should be located alongshore and not inland or deep within a coastal embayment. If these conditions cannot be satisfied, consideration will be given to the establishment of project supported meteorological stations located immediately adjacent to the deployment site. To date, this has not been found necessary and all data is obtained from commercial stations or the U.S. Weather Bureau.

2.3.3 Array Servicing

During the winter months servicing of the instrumentation array deployed in New England waters is determined primarily by problem-dictated sampling frequency and associated record duration. For the majority of deployments using the 4 samples/hour sequence discussed above servicing occurs on a monthly basis. During the late spring and summer this service routine is disturbed by the onset of conditions favoring significant bio-fouling. Experience has indicated that during these periods a bi-weekly service schedule is required to maintain the utility of the optical sensors and cameras and to allow reasonable flow through the conductivity cell. Under these conditions service frequency is typically established with minimal regard for the sampling frequency in use on the array.

2.4 Data Processing

All processing of data obtained by the instrumentation array occurs in the laboratory during the post-deployment period. Tape cassettes are read using a reader specific to the selected data logger (Sea-Data Inc) yielding IBM compatible format placed on standard 1/2 in 9 track magnetic tape. This tape in turn is processed using an IBM 3081-D computer. Programs developed for this analytical phase include a simple data editing, averaging, and plot routine yielding time series plots of all sensor data streams and a series of statistical schemes to analyze principal spectral components, degree of correlation within and between data sets and energy levels characterizing the flow field and associated suspended material concentrations. The availability of these programs permits completion of primary data analysis within four weeks of the array recovery. This analysis also yields plots sufficient for presentation purposes.

Figures IV-2-1 to IV-2-4 present the time series data for current speed, water temperature, salinity and suspended material concentrations from a typical deployment at FVP. Figure IV-2-5 displays the surface wave energy field measured during a storm event.

3.0 CURRENT MEASUREMENTS

Although the DAISY units provide extensive data on the near bottom sediment/water interactions, dispersion of dredged material either during disposal or after resuspension depends on the longer term current regime that is usually dominated by tidal flow, but can be affected by storm events. For subsurface current observations, the General Oceanics (GO) NWCM current meter is the primary sensor used on DAMOS. As discussed below, the GO meter has proved in previous studies to be an effective and reliable instrument. All moorings include an acoustic release mechanism for mooring rotation/retrieval.

3.1 General Oceanics Current Meter

The Model 6011 Niskin Winged Current Meter (NWCM) used was chosen because of its proven reliability and high quality data return and its design which eliminates biasing due to wave motion. Two additional meters considered were the Aanderaa and the VACM, but since both of these instruments utilize Savonius rotors to sense current speeds, which are somewhat fragile in regions of high currents and are sensitive to mooring tilt, the decision was made in favor of the NWCM. Use of the NWCM eliminates these problems as it does not sense current speed with a rotor. Instead, it utilizes its housing (down-current) tilt for speed sensing. The amount of mooring tilt does not affect the instrument speed and direction sensing capabilities, and no data corrections are needed for excessive inclination of the mooring. In addition, the NWCM offers these desirable features:

- o Instrument calibration basically consists of a compass check since the housing dimensions and buoyant weight remain constant.
- o The 20-inch length and 20-pound weight in air can be handled by one person, whereas the VACM is 77 inches long and weighs 160 pounds in air. The Aanderaa is 55 inches long and weighs 56 pounds in air.
- o The standoff supporting the NWCM is clamped onto the mooring line. There is no mooring line segmentation, and therefore, no strength requirements other than to withstand the water pressure. Operational depth is 6000 m.

IV-37

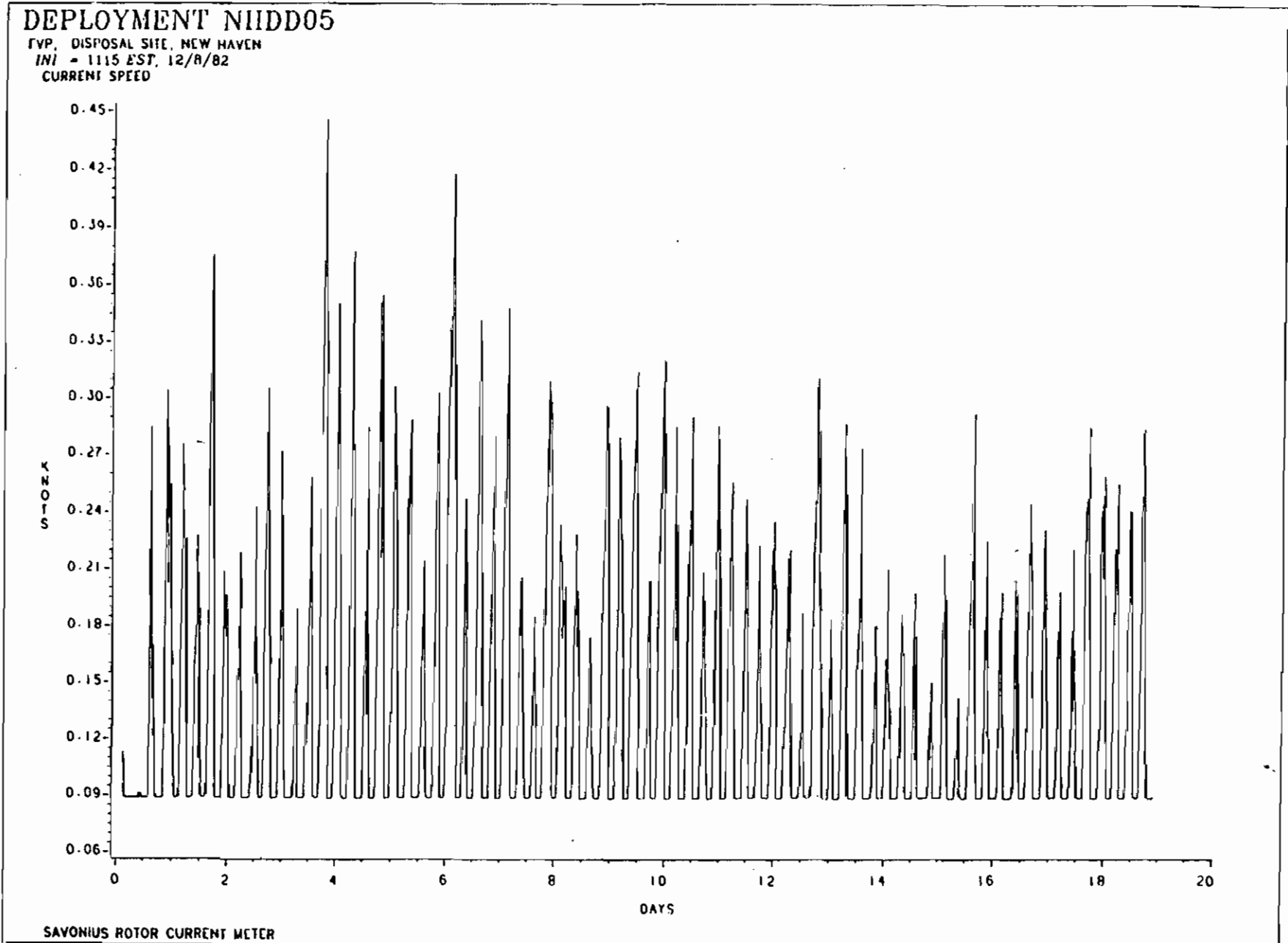

Figure IV-2-1.

Current Speed

Deployment NHDD05

DEPLOYMENT NHDD05

FVP, DISPOSAL SITE, NEW HAVEN
INI + 1115 EST. 12/8/82
TEMPERATURE

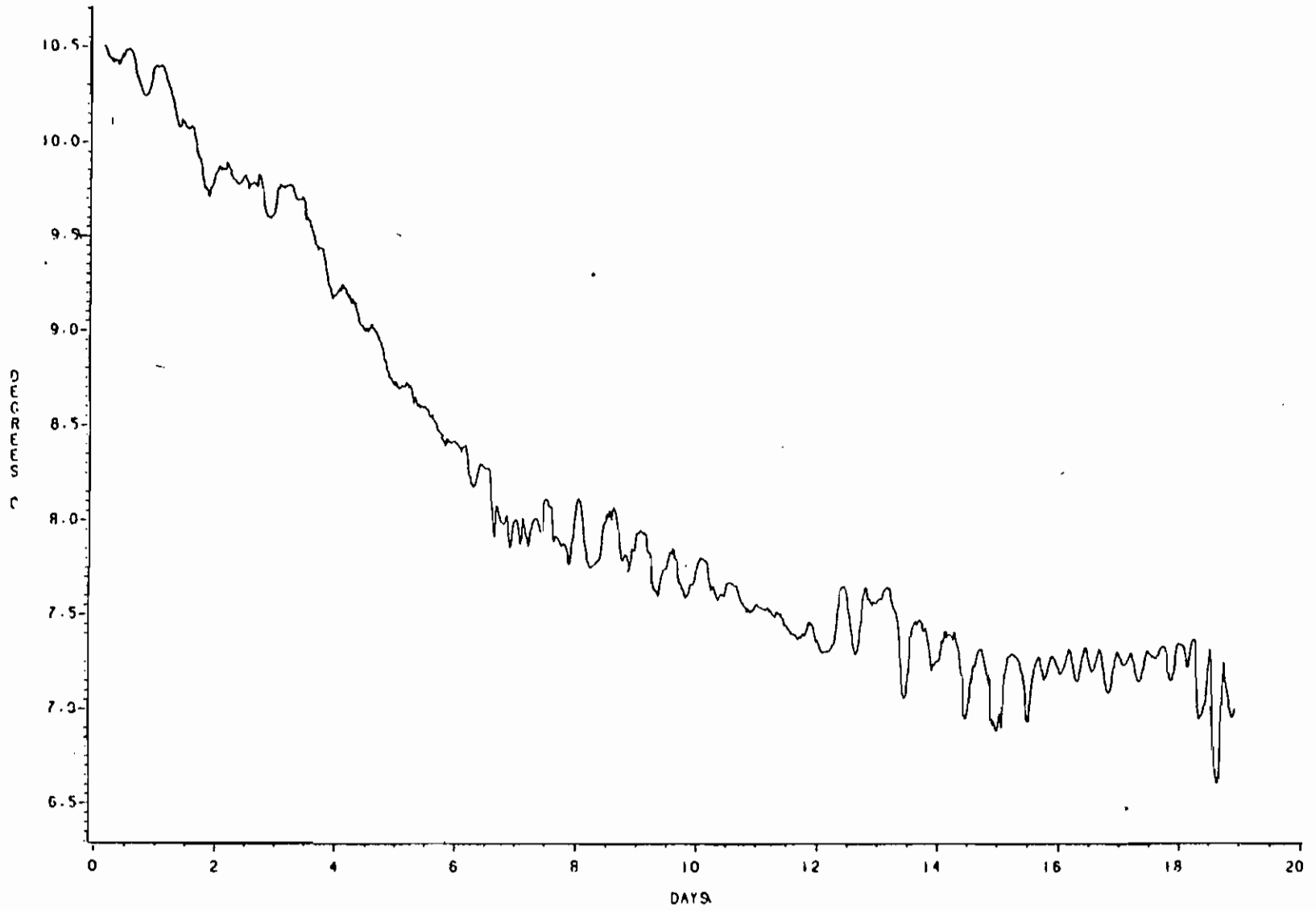

THERMISTOR T3, F-SERIES CALIBRATION

IV-38

Figure IV 2-2.

Water Temperature - Near Bottom
Deployment NHDD05

IV-39

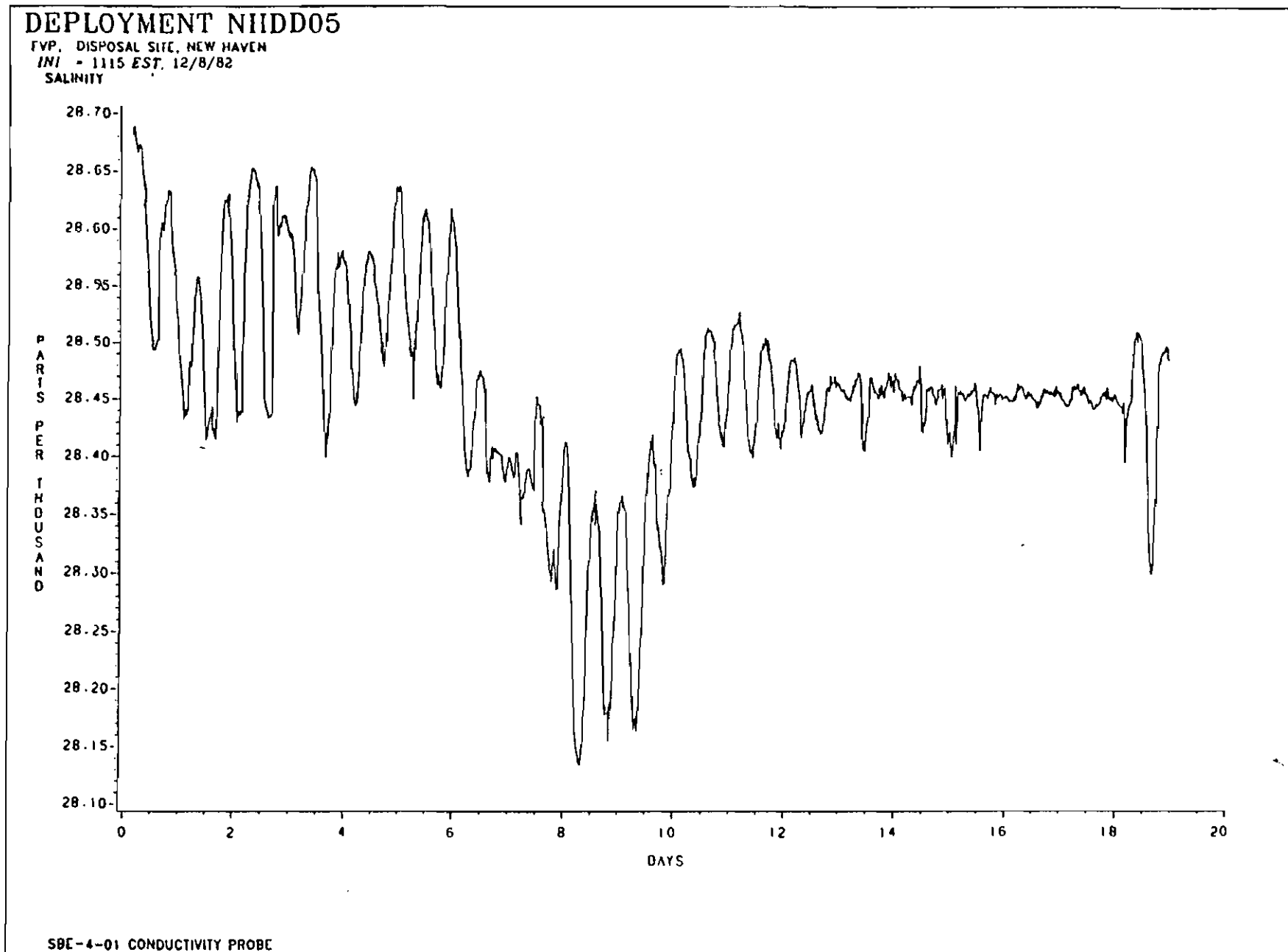

Figure IV-2-3.

Salinity - Near Bottom
Deployment NHDD05

Table IV-3-1

Niskin Winged Current Meter Model 6011 Specifications

Designation:	Niskin Winged Current Meter (NWCM) Model 6011-T
Manufacturer:	General Oceanics, Inc., Miami, FL
Current Speed:	Sensor: Housing tilt Threshold: 2 cm s^{-1} Maximum: 225 cm s^{-1}
Current Direction:	Compass: 3 hall generation; resolution 1° , accuracy $\pm 2^\circ$
Temperature:	Yellow Springs aged linear thermistor; resolution $\pm 1/64^\circ\text{C}$, accuracy $\pm .25^\circ\text{C}$
Time Base:	Source: Crystal oscillator Accuracy $\pm 10 \text{ sec per day}$ Sampling interval: 1 to 512 readings per hour
Data Storage:	Tape Recorder: Digital Capacity: 10,000 readings
Mechanical:	Pressure Housing: 51.3 mm long x 10.5 mm diameter 7075-T6 aluminum, hard coat anodized 6000 meter operating depth
Weight:	20 lbs in air, 10.7 lbs in water
Corrosion protection:	Zinc Anode
Sampling Rate:	A 15-minute sample rate ($\Delta t=15 \text{ min}$) is to be used. This sampling interval will assure resolution of all pertinent velocity fluctuations. A 15-minute interval produces a Nyquist frequency of 48 cycles/ day. This will easily accommodate resolution of tides, any meteorological forcing, eddies, and Loop Current fluctuations.



- o There are no external parts to jam, break, or wear out.
- o The instrument can often be rotated without extensive refurbishing.
- o Using the selectable burst sampling capability allows for averaging which can substantially suppress noise in the measurement.

The Niskin Winged Current Meter (NWCM) Model 6011 is a solid state recording meter with no external moving parts. Specifications are given in Table IV-3-1. The meter is attached with a swivel on a mooring standoff and hangs vertically in the absence of a current. In the presence of a current, the instrument is tilted downstream (Fig. IV-3-1). The angle of tilt varies with the speed of the current. The greater the current, the greater the angle of tilt.

The instrument is fitted with a wing-like structure which stabilizes and orients the instrument in the direction of current flow. The housing contains a tilt sensor (a force balanced inclinometer), three orthogonally mounted hall effect sensors for compass direction, and a thermistor for temperature.

During the mooring period, signals from the sensors are digitized and placed in a 64-bit parallel-in/serial-out shift register together with an associated time code and instrument serial number. The information is then shifted serially and recorded in serial form on a Phillip style magnetic tape cassette. The sampling rate is user selected, and a burst sampling option helps suppress observational noise.

The cassette is read and input directly to a computer where GO software calculates current velocity directly from tilt by converting tilt angle to current speed, using an experimentally determined calibration curve. The three vector components of the earth's magnetic field provided by the hall effect sensors are combined in an appropriate equation to produce magnetic headings.

The results are displayed on strip charts and/or transcribed to a 9 track magnetic tape for further processing and analysis.

3.1.1 Mooring Design

The criteria defined in this section have been used in the design of the moorings.

- a) The inclination angle of each current meter does not exceed 25° from the vertical in order to ensure the data quality.
- b) All instruments are shackled to flotation sufficient to

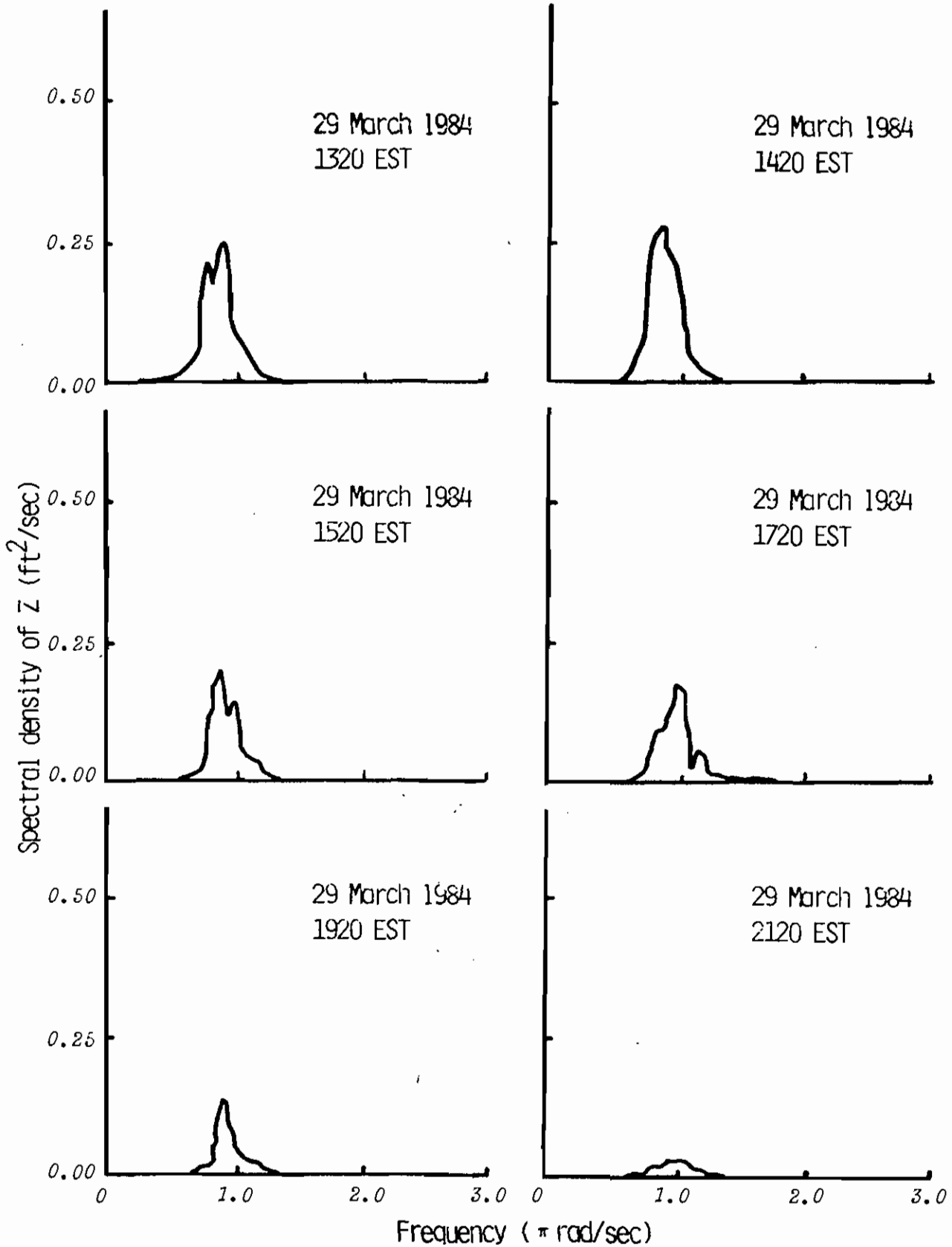

Figure IV-2-5(cont.)



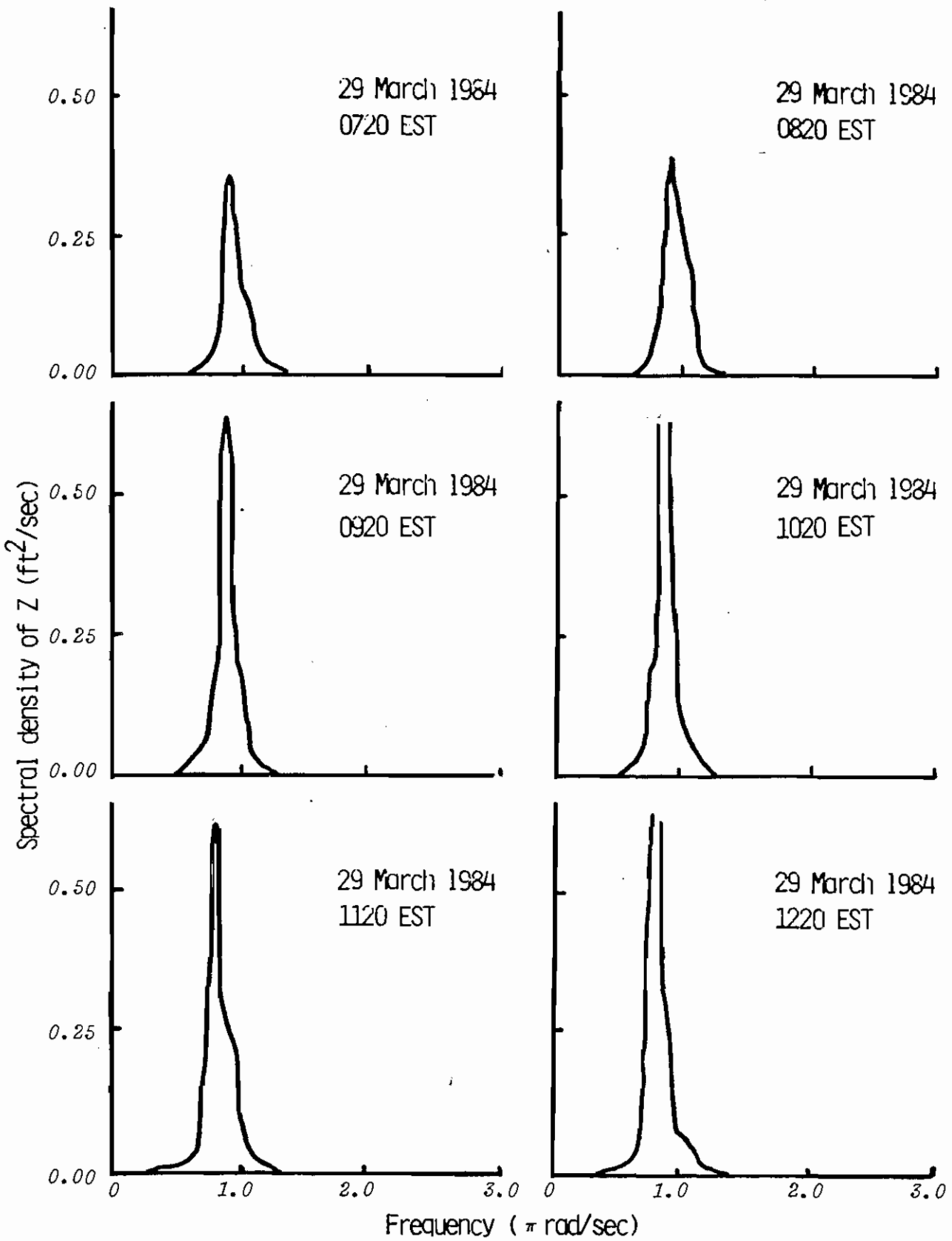

Figure IV-2-5(cont.)



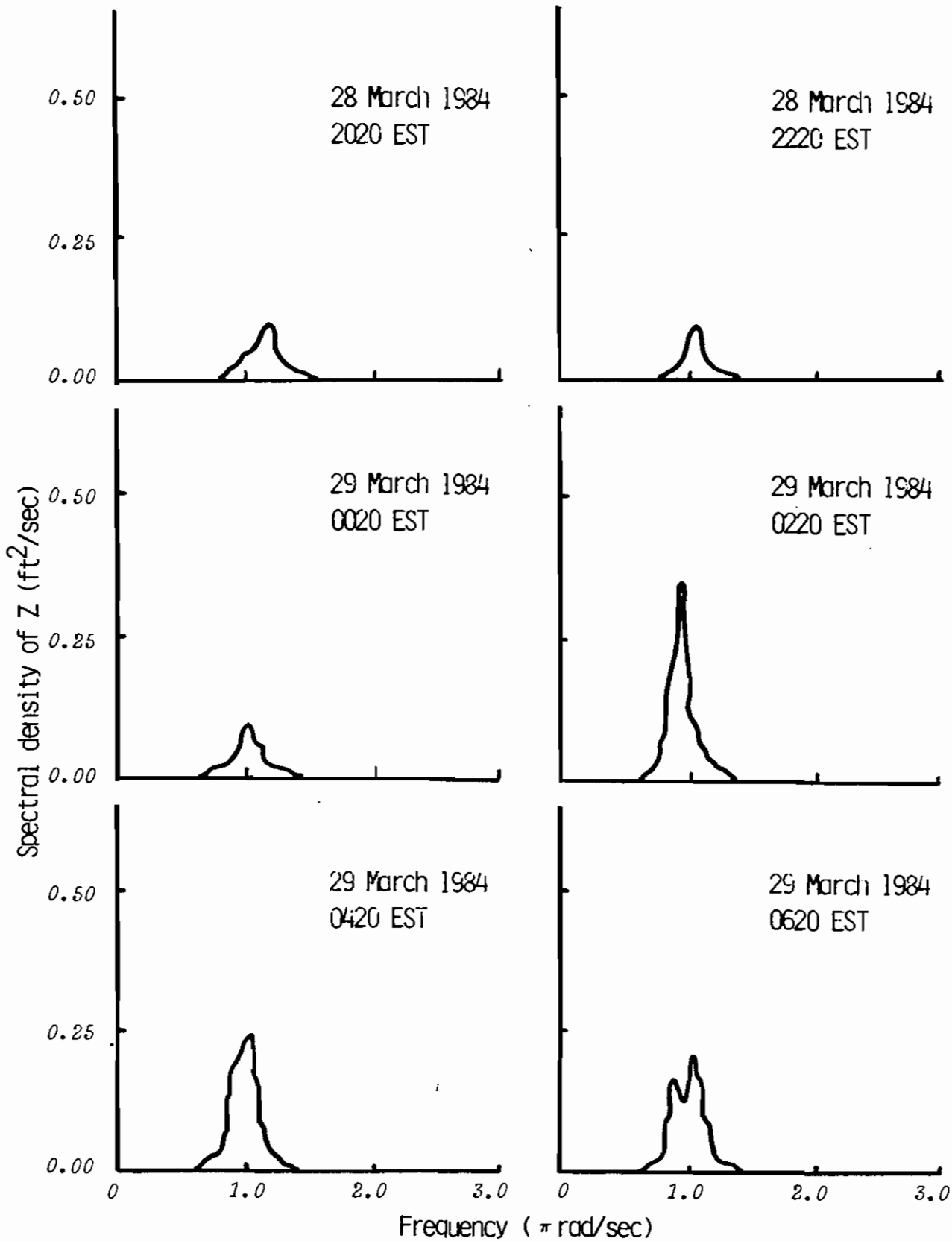
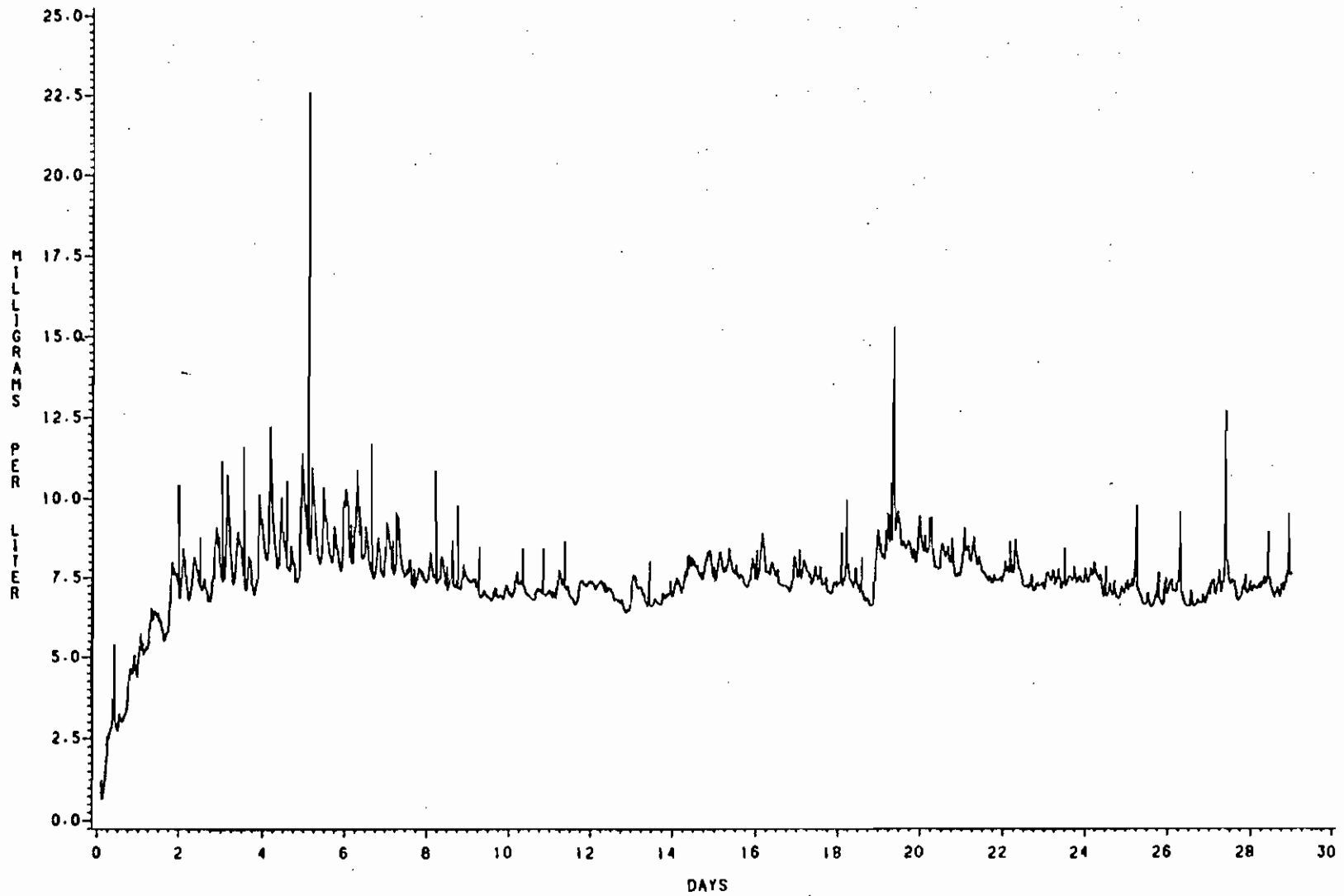

Figure IV-2-5. Surface wave energy field.



DEPLOYMENT NHDD06

FVP, DISPOSAL SITE, NEW HAVEN
INI. = 1030 EDT, 12/27/82
SUSPENDED SOLIDS



NEPHELOMETER NC-5, G-SERIES CALIBRATION

IV-40

Figure IV-2-4. Suspended Material Concentrations
Deployment NHDD06

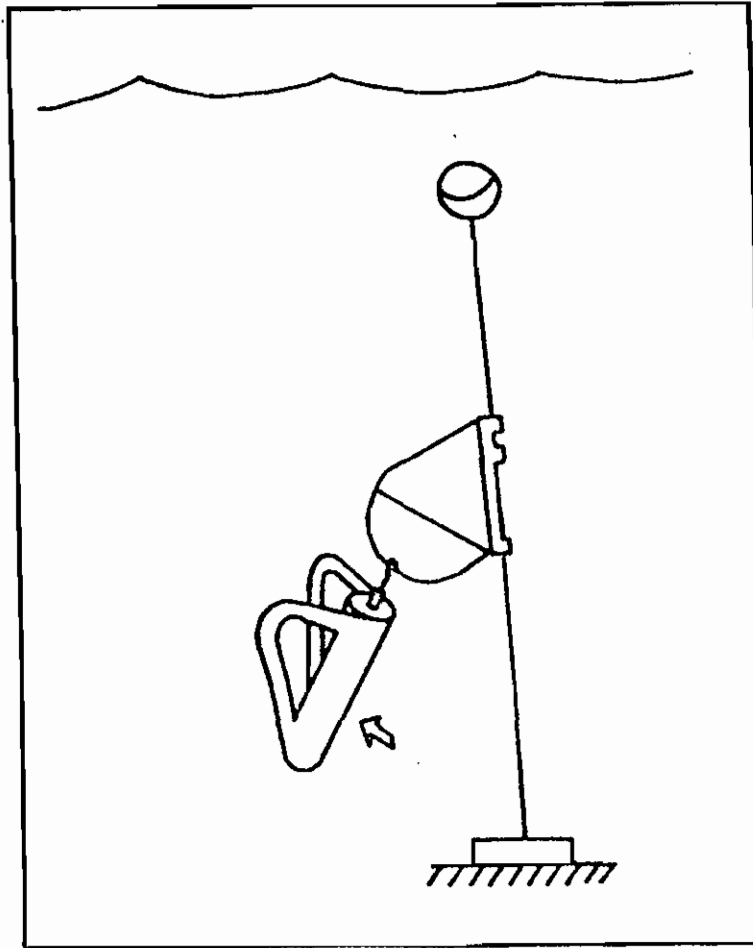

Figure IV-3-1. Niskin winged current meter (NWCM), model 6011, tilting downstream and independent of mooring inclination.

raise the instrument and associated hardware in the event of a mooring failure at any location along the mooring line.

- c) Insofar as possible, galvanized steel is used in the mooring components. Where not possible, dissimilar materials are isolated from one another.
- d) Acoustically actuated release devices are used to detach the anchor from the rest of the mooring system in order to recover the instruments.

The weight of the anchor is designed to insure that the mooring will drag before the mooring wire is subjected to a strain near its elastic limit.

Mooring design involves a process of successive iterations. The first step consists of defining representative vertical current profiles likely to prevail at the sites. This task requires a review of existing literature relevant to the area of interest and of data sets actually collected at the sites, or in their near vicinity, or in dynamically similar environments. It is clear that short of processing actual current meter time series at various depths at the mooring site, one can only make an educated estimate of expected current profiles. Fortunately, moorings have been deployed in similar environments and provide base data for use in developing an appropriate mooring configuration. These data are entered as inputs to the mooring design computer program described below and used for the definition of the static configuration of the first mooring to be deployed. The second step in the design consists of defining a theoretical mooring configuration suitable for the environment in which it will be launched, based on the experience of the design team.

In the third step, adequacy of the mooring design defined in step two is checked by running a computer program originally developed by WHOI which calculates the deflection of the current meter array when submitted to the current profiles defined in step 1, and the tensile load and reserve buoyancy at the elevation of every mooring element.

If some criteria (e.g. maximum allowable inclination) are violated, the mooring configuration will be modified (step two), and step three repeated until the final configuration is such that criteria on instrument inclination, reserve buoyancy, and tensile loads are all met, for the input current profiles selected in step one.

3.1.2 Quality Assurance

Sound quality assurance (QA) is recognized as essential to a productive field measurement operation, since success is judged by the quality and amount of data taken. Our QA involves a careful conformance both to predeployment testing and to detailed post-retrieval performance evaluation. This detailed before and after evaluation assures problem identification and

resolution. Steps and procedures minimizing data degradation and/or equipment loss have been developed for all components of field equipment.

The SAIC Chief Scientist for the deployment cruise has the responsibility to inspect all current meters to insure their checkout/calibration and maintenance prior to deployment and after retrieval. Furthermore, he insures that all current meter moorings are assembled according to design specifications; and that operations are thoroughly documented. The Chief Scientist is also responsible for reviewing the preliminary data reduction transcription procedures used.

Before a current meter is used, it undergoes a testing and checkout procedure. Many of the checked items verify correct operation of the sensors and sequencing and recording system. An important check in any instrument, which must operate reliably for long periods on an internal battery, is the power consumption.

A "Compass Error Table" is produced for each meter by mounting the meter in a test jig which allows it to be tilted at angles of zero, 30° and 60° , while at the same time point in various directions relative to magnetic north. The meter is thus subject in turn to the same conditions produced by zero current, a mid-range, current and a current near to maximum for each of eight different directions around the compass.

Signals picked off from a special monitor connector mounted near the tape recording head on the current meter are fed into a minicomputer. The mini-computer then calculates and displays the tilt and direction angles actually sensed by the current meter so that they could be recorded in the Compass Error Table.

3.1.3 Mooring Deployment and Retrieval

The mooring deployment and retrieval are done by SAIC personnel experienced with shallow and deep water moorings in adverse conditions such as the Gulf Stream. Thus, they are familiar with proper procedures to assure safety and maximum data return.

Deployment of the moorings is accomplished by the anchor-last method, where the top of the mooring is paid out over the stern, while the ship is, usually moving upwind or upcurrent at low speed (less than 2 knots). Payout of the line, instruments, and flotation proceeds under moderate tension in the line until the bottom end of the mooring is finally reached. The anchor is then attached to the lower end of the mooring and released, free-falling to the bottom. This free-fall procedure is considered the safest mode of deployment for it involves a minimum handling time of anchors. If a problem develops on the mooring assembly, then it can be brought aboard with ease. This also reduces the time of maximum mooring load so that the duration of peak transient loads due to wave and ship motions is reduced.

Anchor-last deployment streams the mooring away from the ship which lessens the danger of fouling with the ship. It also provides greater ship maneuverability, which helps in station keeping and allows final adjustments in the mooring location to be made if necessary. Experience has shown that the mooring is not damaged on impact after a free-fall and the buoyancy of the components and subsurface flotation is sufficient to hold the mooring upright during free fall.

Deploying a mooring at a selected location or depth requires a great deal of at-sea experience in similar deployments to maintain line tension within an acceptable range and in selecting the starting point of the deployment procedure with respect to the mooring site. In doing this, the ship's motion relative to the water, mooring length, and complexity of the configuration of the mooring to be deployed must be taken into account. Knowledge of the ship's position through the navigation display and the vessel's response to a combination of wave action, wind and surface currents is essential to a successful operation.

Current meter deployment (as well as retrieval) is greatly facilitated by making use of the SAIC navigation system (described in Section I). This system displays in real time on a video screen the actual ship position with respect to a target point (in this case, the mooring deployment location), and indicates the range and bearing to that location. Ship maneuvers required for a pinpoint deployment (sometimes required because the need to implant a mooring at a precise depth in an area of rugged topography) are thus greatly decreased, and so is the risk of instrument damage upon deployment.

Following deployment of a mooring the transponders on the acoustic release are interrogated and then disabled. Proper receipt of the DISABLE command is indicated when the transponder no longer responds to an interrogate pulse.

The major task associated with mooring recovery is to locate the mooring, and to establish good acoustic contact with the release mechanisms. Once the mooring is released from its anchor and located as it floats to the surface, the operation becomes fairly straightforward.

Typically the ship will be brought into the immediate vicinity of the mooring, using Loran-C for positioning. The acoustic ranging system will then be immersed to determine range to the mooring. Once the distance between the mooring and the ship is reduced to 1 km or less, release mechanisms are actuated and the mooring comes to the surface.

If necessary, an acoustic range measurement is made to determine if the mooring flotation should be visible from the ship's upper deck. Once located, the ship converges on the mooring, keeping it on the lee side.

The general mooring recovery procedure consists of grabbing the subsurface float with a Renfroe hook, attached to a wire winch. A static length of chain (or stopper) approximately

4 m long is attached to the top of the "A" frame with a stainless steel snap hook attached to the free end. Once the surface marker is hooked, the ship is positioned so that the mooring is trailing behind the ship.

The actual mooring hauling procedures for in-line moorings are fairly straightforward. The subsurface buoy is lifted up with the winch and drawn on board by the "A" frame. Load is then transferred from the winch wire to the stopper and snap hook. The section on deck is dismantled and stored. The winch line is reattached below the snap hook and drawn in until the winch has taken up the load. The snap hook is removed and wire is taken up until the next instrument package is landed on the deck. This procedure is repeated until the whole mooring is onboard. Because the instrument to be used in this study is a clamp-on, there is no winch line reattachment and time on station is reduced.

A post-recovery inspection is made of each mooring, noting the condition of instruments, biofouling, corrosion, and any unusual signs of stress.

3.1.4 Data Products

After transcribed tapes are received at SAIC from General Oceanics, a comprehensive quality assurance procedure is initiated. Once evaluated and accepted as valid, the following analyses are conducted and the following standard data products are created:

- o The coordinate system for the velocity vectors is rotated to that of the local isobaths.
- o Velocity vectors are decomposed in the orthogonal components.
- o Each component and temperature are filtered using 3-hour and 40-hour low pass (40-HLP) filters.
- o Stick plots are created using 40-HLP data (Fig. IV-3-2 and IV-3-3).
- o Time series plots of temperature are made (Fig. IV-3-4).
- o For each velocity time series spectra of velocity components are computed using filtered data. Phase and coherence between u and v are computed and plotted (Fig. IV-3-5).
- o Bivariate distributions of current speed and direction are computed for each time series (Table IV-3-2).
- o Bi-weekly and total record means, variance maximums and minimums are computed for u, v and T at each measurement point.

3.2 Neil Brown Direct Reading Current Meter

The Neil Brown Direct Reading Current Meter (DRCM) is used to measure the physical characteristics at a station throughout the water column. These vertical profiles record

0801 R45 0902 R45 0601 R45 0601 R45 0701 R45

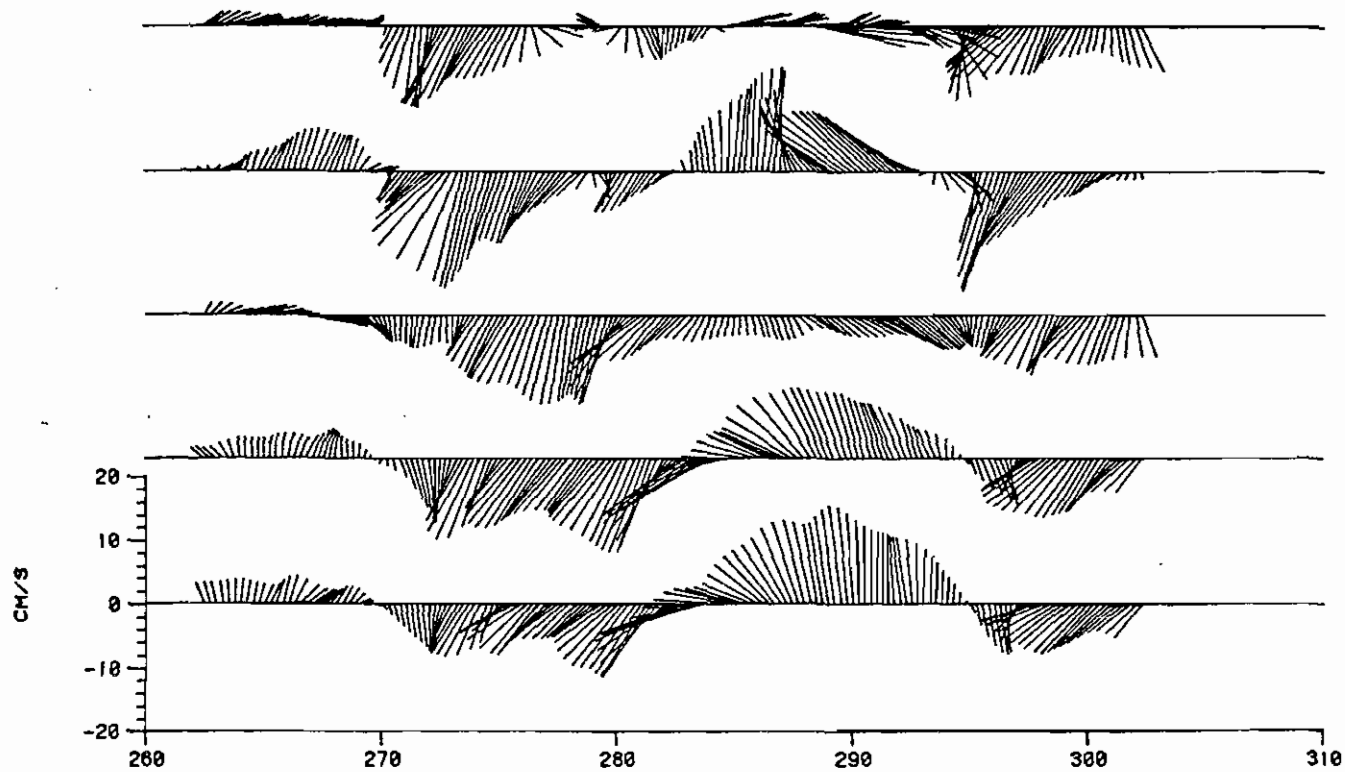

JULIAN DAYS 1976
DAY 260 IS 9/16/1976

Figure IV-3-2. Stick plot of 40-hour low-pass filtered current meter data from the mid-Atlantic Bight.

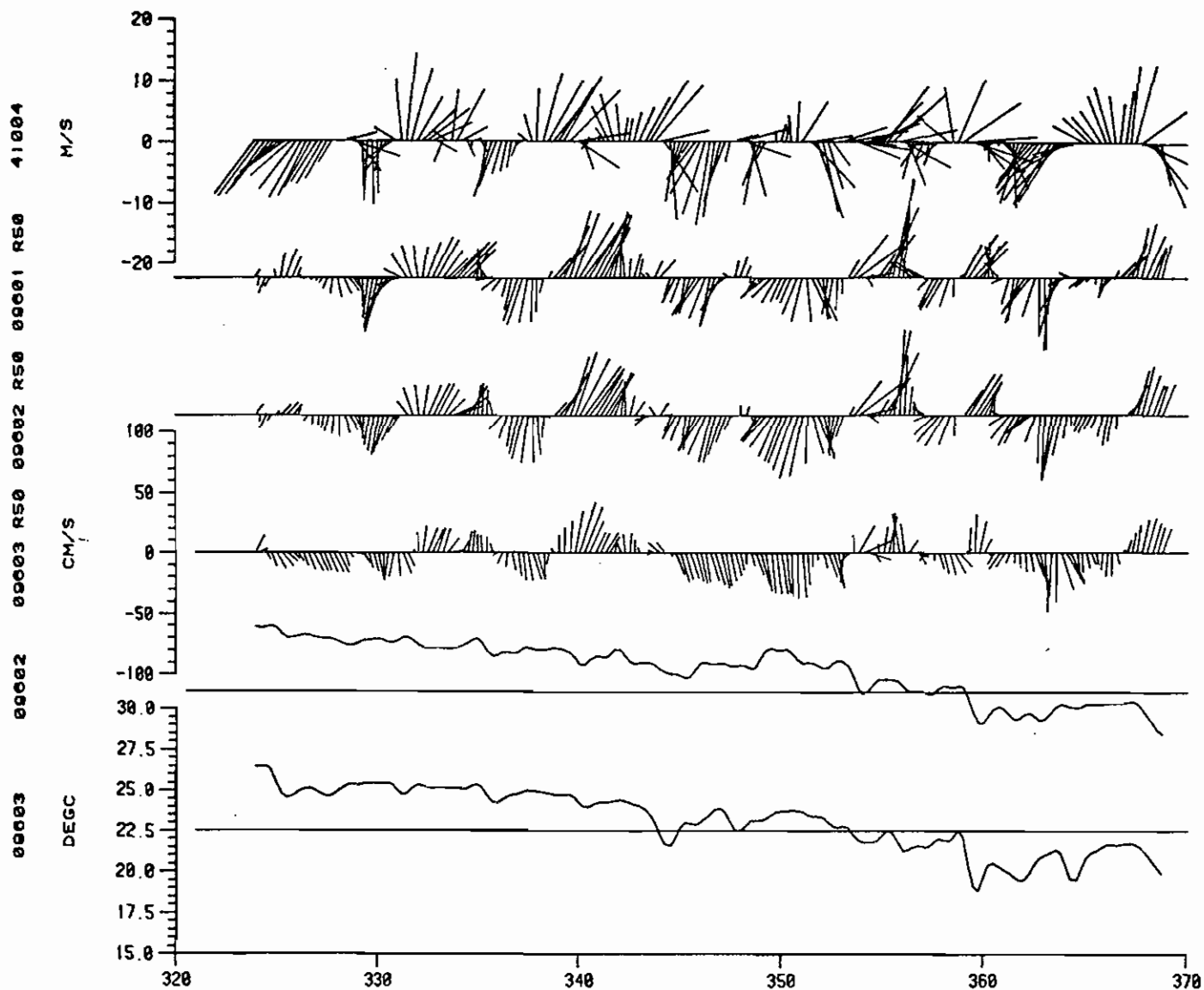

JULIAN DAYS 1978
 DAY 320 IS 11/16/1978

Figure IV-3-3. Temperature stack and current meter stick plots, (40-hour low-pass filtered; current meter data was rotated 50 degrees to align with the local bathymetry).

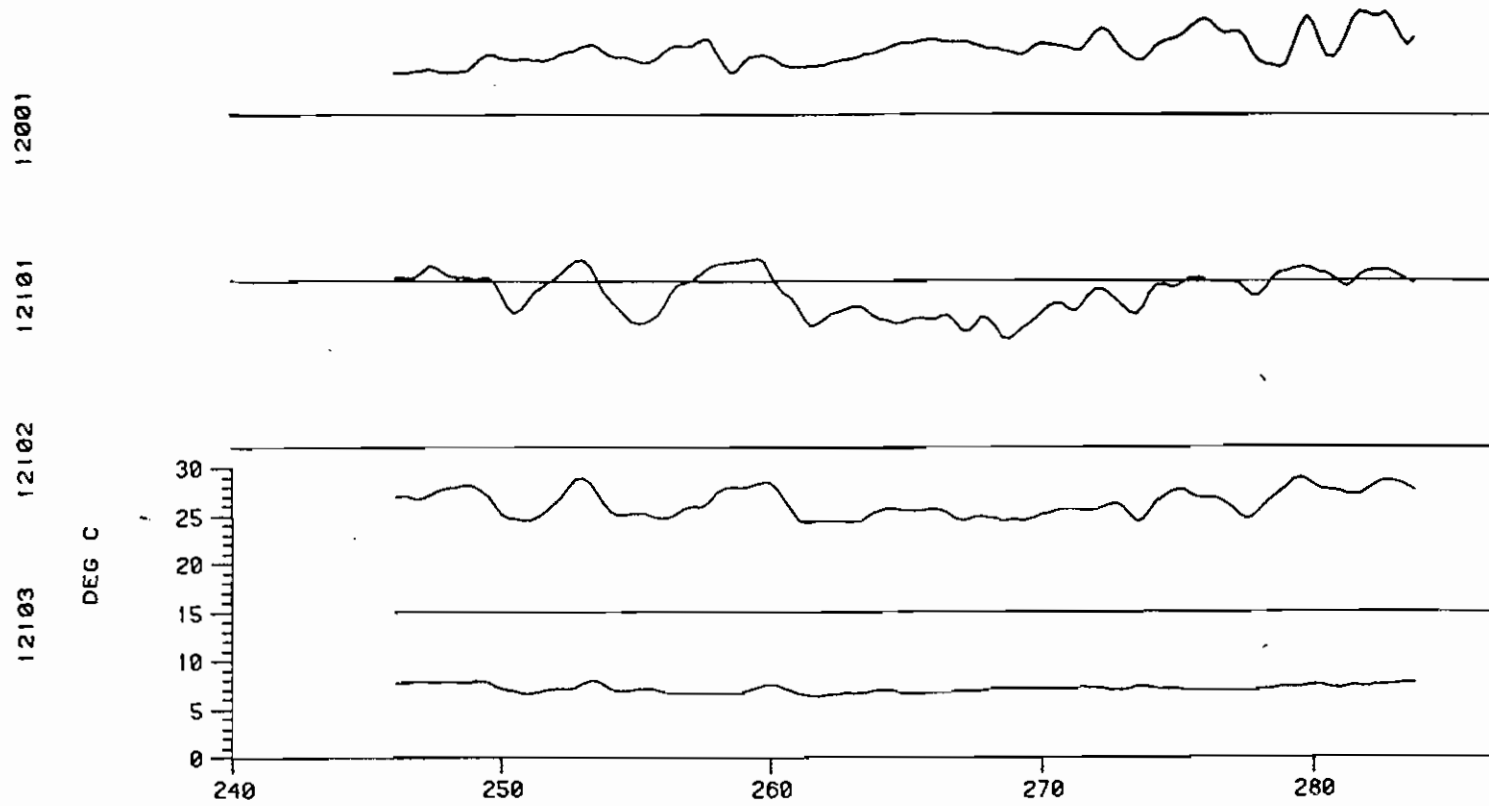

JULIAN DAYS 1980
DAY 240 IS 8/27/1980

Figure IV-3-4. Temperature stack plot of data from the Blake Plateau at 30°N.

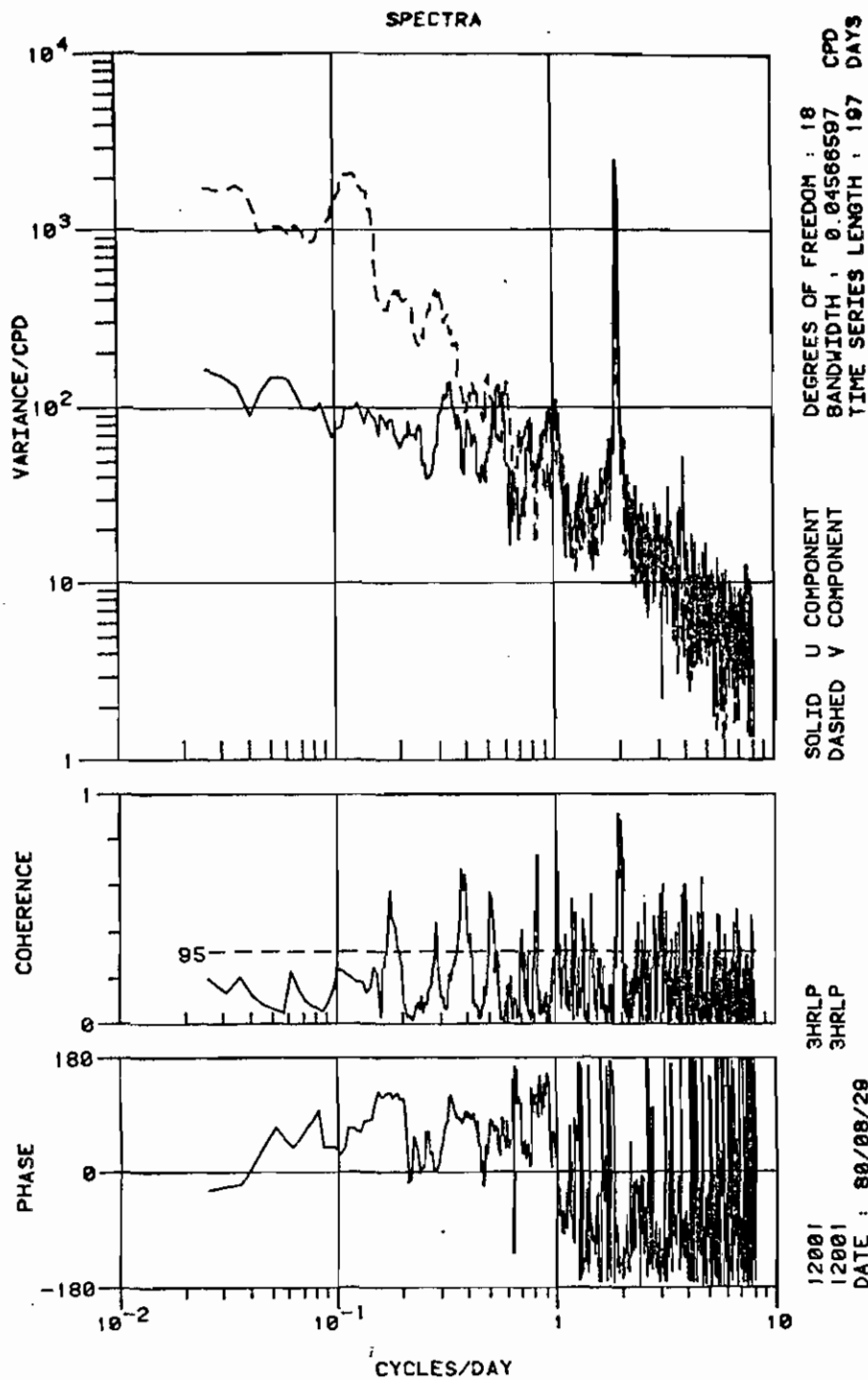

Figure IV-3-5. U and V component spectra, coherence squared, and phase differences for a current meter record.



TABLE IV-3-2.
Bivariate Frequency Distribution for current speed and direction.

FREQUENCY DISTRIBUTION 1.00 HOURLY DATA														STATION# 06701 3HRLP					SPANNING 8/ 3/76 TO 11/ 9/76				
DIRECTION DEGREES														PERCENT	MEAN SPEED	MIN SPEED	MAX SPEED	STD. DEV.					
0- 30	.6	1.1	.8	.1	.0	.0	.0	.0	.0	.0	.0	.0	.0	2.6	4.95	1.06	9.86	2.33					
30- 60	.8	1.3	1.5	.2	.0	.0	.0	.0	.0	.0	.0	.0	.0	3.7	5.37	.94	11.66	2.50					
60- 90	1.1	2.1	1.8	.4	.1	.0	.0	.0	.0	.0	.0	.0	.0	5.5	5.65	1.09	38.43	4.20					
90-120	1.4	4.4	2.5	.6	.3	.0	.2	.1	.0	.2	.1	.0	.0	9.8	7.22	.94	40.04	6.44					
120-150	1.5	3.9	3.6	1.5	.5	.2	.3	.1	.1	.0	.0	.0	.0	11.5	7.07	.83	28.96	4.48					
150-180	1.7	3.3	3.0	1.5	.2	.1	.1	.1	.0	.0	.0	.0	.0	10.0	6.58	.67	27.26	4.38					
180-210	1.2	4.3	3.7	1.4	.2	.2	.0	.0	.0	.0	.0	.0	.0	11.1	6.47	.42	31.32	3.74					
210-240	1.4	4.5	3.9	2.8	1.6	.5	.2	.0	.0	.0	.0	.0	.0	15.0	7.75	.45	39.30	4.54					
240-270	.9	3.4	4.2	4.1	2.8	.6	.1	.0	.0	.0	.0	.0	.0	16.2	8.74	.94	21.01	4.06					
270-300	.9	1.5	1.7	1.8	.8	.3	.1	.0	.0	.0	.0	.0	.0	7.1	7.99	.26	18.33	4.25					
300-330	.9	1.9	1.3	.3	.0	.0	.0	.0	.0	.0	.0	.0	.0	4.4	5.17	.47	13.37	2.82					
330-360	.6	1.5	.5	.3	.0	.0	.0	.0	.0	.0	.0	.0	.0	3.0	4.93	1.15	10.84	2.54					
SPEED	0	3	6	9	12	15	18	21	24	27	30	33	36	39									
CM/S	1	1	1	1	1	1	1	1	1	1	1	1	1	1									
	3	6	9	12	15	18	21	24	27	30	33	36	39	42									
PERCENT	13.1	33.1	28.5	14.8	6.4	1.9	.9	.4	.2	.3	.1	.0	.0	.1	100.00								
MEAN DIR	177	182	183	214	229	231	183	150	154	122	138	96	79	142									
STD DEV	90	83	79	66	52	32	62	57	47	22	36	0	0	77									

SUMMARY STATISTICS

MEAN SPEED = 7.06 CM/S MAXIMUM = 40.04 CM/S MINIMUM = .26 CM/S RANGE = 39.77 CM/S
STANDARD DEVIATION = 4.32 CM/S SKEWNESS = 2.11

IN A COORDINATE SYSTEM WHOSE Y AXIS IS POSITIONED .00 DEGREES CLOCKWISE FROM TRUE NORTH
MEAN X COMPONENT = -1.24 CM/S STANDARD DEVIATION = 6.40 CM/S SKEWNESS = .52
MEAN Y COMPONENT = -2.50 CM/S STANDARD DEVIATION = 4.45 CM/S SKEWNESS = -.54



current speed, current direction, pressure, temperature, salinity, and conductivity as the sensor probe is allowed to descend through the water column as rapidly as possible. Table IV-3-3 contains the variables measured by the DRCM.

3.2.1 Data Collection

Vertical profiles are taken at current meter deployments and retrievals as a real time check against the data recorded on the current meters. Additional profiles are conducted during any water column sampling and during plume studies where the suspended sediment layer is tracked throughout the water column.

The DRCM display unit is connected via RS232C serial cable to the SAIC Navigation and Data Acquisition System computer. Software created by SAIC records all data fields from the DRCM as the probe is lowered through the water column. The navigation system also determines and stores the position of the ship 5 minutes prior to the beginning and five minutes past the end of the cast to calculate the drift of the ship. This information is then used to correct the current speed results.

3.2.2 Presentation of Results

Figure IV-3-6 depicts a plot of the variables measured by the DRCM against depth as produced by the software module created for this type of data. Tabular data is also available when required.

4.0 SCUBA AND DEEP WATER IN-SITU ASSESSMENT OF CONDITIONS AT DREDGED MATERIAL DISPOSAL SITES

4.1 Observations of Benthic Conditions

Observations of benthic conditions include a series of qualitative and quantitative surveys at pre, active and post-disposal phases. The following description indicates objectives and procedures employed during the three dredged material management phases.

4.1.1 Pre-Site Designation and Disposal

Linear bottom transects (50-100 m) are conducted to describe benthic fauna/substrate characteristics, including:

- o Diver counts of mobil macrofauna are obtained to identify organisms missed by conventional sampling devices and to accurately describe patch concentrations and horizontal variability of resident species.

Table IV-3-3

Variables Measured By Neil Brown DRCM

<u>Variable</u>	<u>Units</u>	<u>Precision</u>
Current speed	cm/s	(0.0)
Current direction	degrees magnetic	(0.0)
Pressure	millibars	(0.0)
Temperature	degrees, C°	(0.00)
Conductivity	mmhos/cm	(0.00)
Salinity	ppt	(0.00)



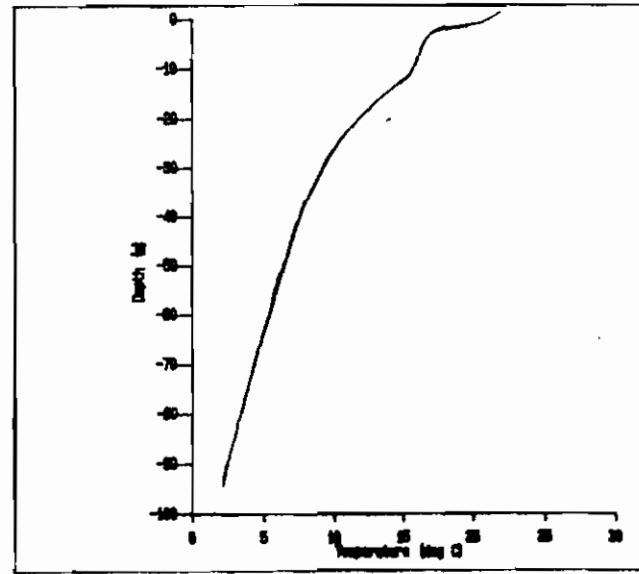
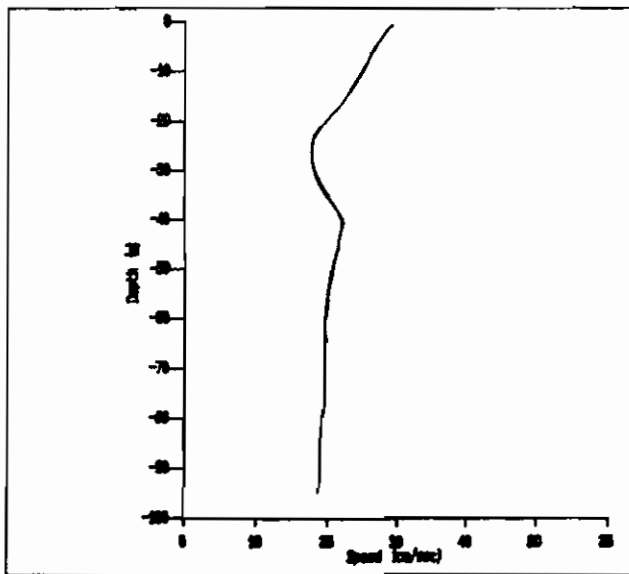
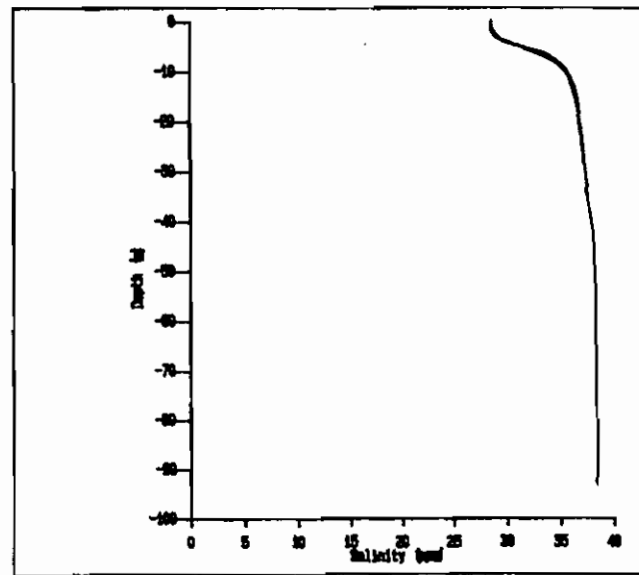
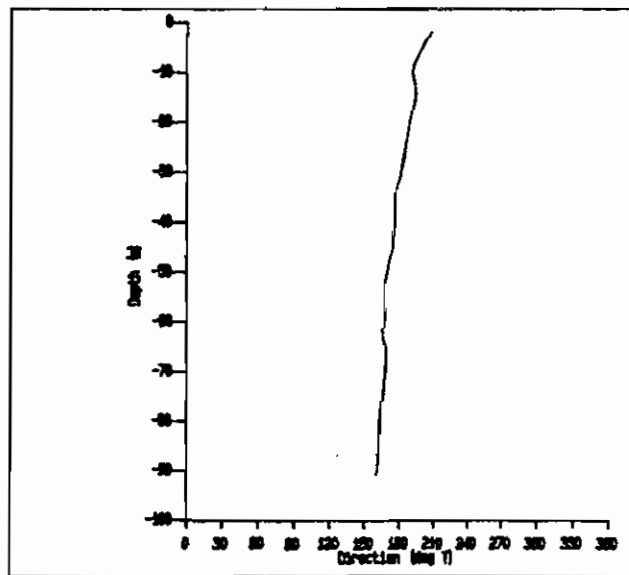

Figure IV-3-6. Sample plot of results from Neil Brown DRCM.



- o Extensive photography (35 mm or video) is taken for permanent records of fauna/substrate ecology and existing sediment surface features. Quantitative values for sessile organisms are calculated for m² coverage, along transect and between season variation.
- o Attention to valuable commercial species and supportive habitat assures proper site selection and avoids impact to fisheries resources (i.e. lobster burrow beds, hard substrate/reef outcrops).
- o Within the 1 NM designated area, fine scale inspection of the point target site are conducted based on precision bathymetry and sediment data. Final diver counts, samples and photography focus on the primary impact zone (approx. 200 m radius).

4.1.2 Active Disposal Phase

During the period of disposal, interim surveys are conducted to:

- o Verify the perimeter of dredged material discharge limits; correlate actual visual border fixes with bathymetry and REMOTS coordinates; chart changing frontal locations and relate final mound geometry to mass balance calculations.
- o Observe and note behavior of species to the boundary nepheloid layer and describe suspension/bio-erosion processes occurring within deposited dredged material.
- o Search for in-situ evidence of abnormal mass mortality in immediate disposal zone due to toxics or contaminants.
- o Gauge effectiveness of material management operational strategies through procedures to
 - Check for target (point) accuracy of disposal by direct underwater reconnaissance.
 - Identify and confirm any errant barge disposal resulting from side-scan bathymetry or fishing industry indications.
 - Document the process of sequential mound creation and intentional "capping". Describe the surface features and final compaction stages of capped (sand vs. mud) mounds.
- o Monitor, through a series of quarterly (seasonal) dives, the behavior (feeding, shelter, reproduction) of major resource species (benthic finfish, crustacea,

mollusk) attracted to the disposal site.

- o For different geographic regions, characterize the species behavior within dredged material sites according to stabilizing or bioturbation forces on newly deposited material.

4.1.3 Post Disposal Long-Term Assessment

Following completion of disposal, in-situ assessments are made in conjunction with DAMOS cruise including: photographic transects to document the recolonization patterns; topographic features of the mound; and final "altered habitat" conditions. Specific tasks conducted during this phase include:

- o Inspecting adjacent natural benthic communities to detect change in species composition or siltation impacts.
- o Survey of the sediment compaction.
- o Recording and sampling examples of unique organisms presence (or dominance) and the degree of utilization of dredged mounds by successional infauna and commercial resource species. Opportunistically collect abundant species samples for bioaccumulation analyses; and recommend "indicator species" based on observed predominance and substrate feeding type.

4.2 Physical and Biological Benthic Conditions

During the site selection, active disposal and post disposal phases, certain key in-situ factors are logged routinely for all SCUBA, submersible or ROV transects. These observations fall under two categories, physical and biological benthic conditions. Table IV-4-1 shows a sample diver log sheet used to record the bottom conditions during each dive.

Physical Benthic Conditions:

- a) bottom current, velocity and direction
- b) turbidity (diver visibility), nepheloid layer characteristics
- c) sediment grain size, surface structural features (i.e. ripple zones, mound fractures)
- d) sediment composition (i.e. shell hash, sand/silt)
- e) topography (i.e. mound dimensions, slope/contour/apron)
- f) compaction/suspension potential of deposited sediments
- g) bioturbation (i.e. degree of mobil species activity, burrow excavation depths and frequency).

D.A.M.O.S. DIVER MONITORING LOG

DATE: LOCATION:
 DIVERS: TIME: DEPTH: T°C: VISIBILITY:
 DIVE (in/out Loran C): DISPOSAL or REFERENCE BUOY L/C:

I. OBSERVATIONS:

- A. BENTHIC CONDITIONS (PHYSICAL) - Bottom current vel. and direction, turbidity, sediment grain size, neffloid layer, surface features (composition), shell hash (% cover), topography (slope/contour/apron), compaction, bioturbation, perimeter Loran C.
- B. (BIOLOGICAL) - Diver species count, densities (est. no.) photo log nos., spõil/organism dynamics, behavior, transect observations (on/off) difference, biogenic sediment structures (burrows, tubes, tracks, casts, etc.).

II. DISCRETE SAMPLES OR METHODS:

- _____ A. Epibenthic net (30 sec. traverse): on or off spõil, target species
- _____ B. .25 m² quadrant count/photography.
- _____ C. Penetrometer tests, elevation stake readings, sediment trap.
- _____ D. Mussei deployment - bioaccumulation subsample.
- _____ E. Sonic beacon placement or electrolyte change.
- _____ F. Remote bathymetric camera photos.
- _____ G. Video tape (location, time min. run, tape index).
- _____ H. Opportunistic collection (i.e. natural mussel bed, Corymorpha Axius).

Biological Conditions:

- a) diver species count, estimate densities of gregarious/opportunistic species.
- b) behavior of prime motile megabenthic species (i.e. attraction/repulsion to dredged mound, bioturbation intensity, target fisheries resources)
- c) Identification of "indicator species."
- d) Description of biogenic structures and changes of habitat over time (i.e. burrows, tubes, tracks, casts).
- e) Contrast on/off conditions of dredged material mound biota vs. adjacent ambient substrate communities.

Several quantitative and site-specific methods are employed to obtain repetitive in-situ data in a standard format. Sampling methodologies that have proven complimentary and 'fill the gaps' for conventional environmental assessment procedures are as follows:

- o Benthic line transect staked on bottom to repeat photography/sampling at predetermined stations or intervals.
- o Calibrated photographic systems to quantitatively determine species abundance and distribution (i.e. 0.5 m² 35 mm still photography, video analytic techniques).
- o PVC square frames for diver count of sessile organism density/burrows/shell hash composition.
- o Core samples - discrete diver or submersible obtained 20 cm deep sediment cores at precise locations (i.e. mound, apron, adjacent natural sediment).
- o Air lift or suction samples of hard rock fouling communities to fully collect and typify community assemblages (i.e. algae, invertebrates, predator-prey, larval assemblages).
- o Penetrometer instrument to obtain relative compaction value of sediment; elevation stakes to determine surface sediment erosion.
- o Sonic beacon placement at apron regions to chart frontal boundary, perimeter location, and mussel bioaccumulation stations.
- o Remote camera long-transect photography, for deep or greater areal coverage, provides extensive 35 mm data and video records to obtain site characterization and quantitative species enumerations.

4.3 Analysis of Still and Video Imagery

In order to determine standard viewing dimensions for 35 mm still and video cameras on various undersea vehicles (e.g. ROV, manned submersible), calibration techniques were developed on a case by case basis. For the ROV-Recon IV and manned submersible Mermaid II, still and video cameras were calibrated by placing a grid (10 cm, 5 cm, and 2.5 cm grid squares) in the field of view with vehicles submerged. Still photographs and a series of video images over the tilt range of the system of the grid were traced from standardized viewing systems (e.g. microfilm reader and video monitor) onto plastic sheets. Each grid image was expanded to cover the entire area of view using standard photogrammetric techniques, and area of coverage determined. A table of tilt angles and areas of coverage was constructed for the video system, so instantaneous area of coverage for any tilt angle from a video transect could be interpolated. Calibration of both still and video system for the manned submersible Johnson-Sea-Link was accomplished using a parallel laser pointing system (10 cm point-to-point) which appeared in the field of view. Still camera images from a forward position on a fixed mount were taken with the parallel laser points in various areas of the photograph and calibrated using the procedures previously described. Video imagery was taken with the camera in a fixed position through a series of changes in lens focal length. Path width was computed at various lens focal lengths.

Still photographs along a transect were taken as a representative series. Photographs were projected, physical characteristics of the substrate described and all animals enumerated to the lowest possible taxon. Mean densities were computed for individual taxa and standardized to number per m^2 .

Video imagery was treated as a series of short strip transects with each dive. Tapes were reviewed and an average tilt angle determined or the tilt angle was standardized. For ROV imagery, a transect was completed when five continuous fields of view (FOV) were observed on the screen. A FOV is defined as the closest point to the camera (bottom of monitor) to the horizon (farthest visible distance on the monitor). Area of coverage for a transect was computed by determining the instantaneous area of coverage for a video frame and multiplying by 5. Limitations due to visibility and camera angle of coverage produced average transect lengths of 1 m \pm .2 m. Manned submersible video transects were treated as long strip transects (100 m) with path widths determined from camera calibration and transect lengths computed from submersible tracking by the surface vessel. In both cases, animals were identified to the lowest possible taxon, densities determined, and extrapolated to number per m^2 .

Still and video documentation was stratified by habitat type for specific density determinations of key organisms (i.e. on/off dredged material, soft vs. hard substrate). Due to the irregular nature of bottom topography over hard rock and ledge areas, all submersible vehicle imagery was obtained by flying the

system over the substrate rather than in contact with it. Height of the lens off bottom of each photographic system was more variable in these areas, hence varying the area of coverage. Error of this nature will result in slight overestimates in density computations.

4.4 Data Products

In situ assessment of disposal site conditions provide qualitative results such as photographs and video tape that are presented in reports or at public forums to develop an overall understanding of the disposal site environment. Quantitative measurements such as location of dredged material margins, number of motile species per m^2 etc. are included in reports for the DAMOS program.

V. STANDARD OPERATING PROCEDURES FOR THE DAMOS PROJECT DATA BASE

1.0 INTRODUCTION

Science Applications International Corporation (SAIC) has designed and implemented a data base management system using the INFO data/file management software currently existing on a Harris minicomputer at the NED facility in Waltham, MA.

The DAMOS Project Data Base (PDB) has been adapted from an existing information resource framework known as the Scientific Information Management and Analysis System (SIMAS) which SAIC has developed over the last seven years. The SIMAS was designed to provide a comprehensive capability for data management and can be readily applied to the DAMOS program.

The PDB includes four basic types of files. The inventory file contains information defining where and when the samples were collected. The data files contain the historical data together with the project-generated field and laboratory observations. Parameter files contain lists of parameters present in some of the data files together with ancillary information about the parameters. The documentation and quality control files contain detailed information on equipment requirements, methodologies, field logs, equipment performance criteria, instrument calibrations, and field and laboratory QC/QA measurements.

Interfacing with the PDB are five program modules which address (1) the entry and verification of information in the PDB; (2) retrieval and manipulation of information in the PDB; (3) generation of information required for program management purposes; (4) generation of information for statistical and mathematical analysis; and (5) report writing. Implementing such modules on the NED Harris computer system involves coding of programs within INFO as well as linking other software to the INFO system.

2.0 THE DAMOS PROJECT DATA BASE

As mentioned above, the DAMOS PDB is managed with the INFO software package. INFO employs a relational data model to store information. Each file in INFO consists of one record type which can be linked with other files via a common attribute. INFO includes a powerful query language for retrieving information from the files, and a report-writing module which permits the creation of customized displays. Data can be entered into INFO either interactively or via batch.

2.1 Data Base Design

A major objective in designing the PDB is to implement an 'open-ended' structure which permits the incorporation of

other types of data in the future. The design is expressed in a schema which is essentially a "map" depicting the contents of the various files in the PDB and how these files can be cross-referenced and linked together. The schema provides the blueprint by which the PDB is implemented in the subsequent task.

The PDB for DAMOS will contain inventory, data, parameter and documentation files. The management files are not required in this effort, since this type of file is generally used only in planning and administrating field efforts. However, the management files can be easily incorporated into the PDB at a later date if desired.

2.1.1 Inventory File

The inventory file contains information describing where and when each sample was collected. A primary function of the inventory is to serve as a central directory for all historical and project-generated samples. Each entry in the inventory file corresponds to a sample from a particular study and contains a sample number, the data type, the collection date and time, the cruise designation, the sampling station designation, and the geographical coordinates of the sampling station. Table V-2-1 lists the structure of the DAMOS inventory file. The inventory files can be cross referenced with the data files via the sample number.

Another principal function of the inventory file is to define spatial and temporal subsets of the data for retrieval. Using the INFO query language, a set of spatial and temporal criteria can be specified and the inventory file searched for those samples satisfying the criteria. The inventory entries satisfying the search criteria can then be merged with the data files to create a data subset. The inventory file can also be used to generate summary tables displaying the types, locations and dates of data present in the PDB.

2.1.2 Data Files

The PDB data files contain the project-generated and historical data. The basic unit of organization within the data files will be the sample. Different types of data such as physical, geological, chemical and biological are stored in different files. Since each sample is identified by a unique number, the information in the data files can be cross referenced with each other using the inventory file.

There are currently five data files in the DAMOS PDB, and Table V-2-2 presents the structure of these files. The taxonomic file contains the benthic taxonomic identification and abundance information. The chemistry file holds the sediment chemistry information, and the sediment file contains the grain size information. The taxonomic and chemistry files utilize a parameter code to denote the organism or chemical measured in a sample. This method allows only non-zero observations to be stored in the PDB thereby saving storage space on the computer.

Table V-2-1
Structure of the DAMOS Inventory File

INVENTORY FILE

FILE NAME: INVENTORY

<u>Name</u>	<u>Width</u>	<u>Type</u>	<u>Decimal Places</u>	<u>Comments</u>
SAMP:ID	6	C		Sample Identifier
REP:TOT	3	N		Total No. of Replicates
STUDY	12	C		Study Identifier
CRUISE	10	C		Cruise Identifier
STATION	11	C		Station Identifier
MONTH	2	I		Collection Date
DAY	2	I		Collection Date
YEAR	2	I		Collection Date
HOUR	3	I		Collection Time
MINUTE	2	I		Collection Time
LAT_DEG	2	I		Collection Location Latitude
LAT_MIN	2	I	3	
LAT_HEM	1	C		
LNG_DEG	3	I		Collection Location Longitude
LNG_MIN	2	I	3	
LNG_HEM	1	C		
SAMP_TYPE	6	C		Sample Type



Table V-2-2
Structure of the DAMOS Data Files

DATA FILES

FILE NAME: TAXA_DATA

<u>Name</u>	<u>Width</u>	<u>Type</u>	<u>Decimal Places</u>	<u>Comments</u>
SAMP:ID	6	C		Sample Identifier
REP	2	I		Replicate Number
TAXA_CODE	6	I		Parameter Code
LIFE_STAGE	2	C		Life Stage
COUNT	6	I		Abundance

FILE NAME: CHEM_DATA

<u>Name</u>	<u>Width</u>	<u>Type</u>	<u>Decimal Places</u>	<u>Comments</u>
SAMP:ID	6	C		Sample Identifier
REP	2	I		Replicate Number
CHEMCODE	6	I		Parameter Code
MEASCODE	2	C		Measurement Code
METHCODE	2	C		Method Code
BDLFLAG	1	C		Below Detection Limit Flag
CONC	6	I		Concentration
EXPONENT	2	I		Concentration Exponent



Table V-2-2 (Cont.)

FILE NAME: DISPOSAL

<u>Name</u>	<u>Width</u>	<u>Type</u>	<u>Decimal Places</u>	<u>Comments</u>
SAMP_ID	6	C		Sample Identifier
TIME	4	I		Time
POS	40	C		Relative Position
LORAN	40	C		Loran Fixes
SOURCE	40	C		Material Source
VOLUME	6	I		Volume of Disposed Material

FILE NAME: SEDIMENT

<u>Name</u>	<u>Width</u>	<u>Type</u>	<u>Decimal Places</u>	<u>Comments</u>
SAMP:ID	6	C		Sample Identifier
REP	2	N		Replicate Number
VISUAL	40	C		Visual Observation
MED	6	N	4	25% Quantel
Q1	6	N	4	50% Quantel
Q3	6	N	4	75% Quantel
SOIL	2	C		Soil Class
DIST	1	C		Distribution
FINES	6	N		Percent Fines
SPGRAV	6	N	2	Specific Gravity
RAD1	3	N		Radioactivity
RAD2	6	N	1	Radioactivity
PH	4	N	1	pH



Table V-2-2 (Cont.)

FILE NAME: REMOTS

<u>Name</u>	<u>Width</u>	<u>Type</u>	<u>Decimal Places</u>	<u>Comments</u>
SAMP:ID	6	C		Sample Identifier
REPLI	2	N		Replicate Number
GRAINMDE	8	C		Grain Size Major Mode
GRAINRNG	5	C		Grain Size Range
PENETRA	5	N	2	Average Penetration
BNDRYLBL	11	C		Boundary Rough. Label
BNDRYVAL	4	N	2	Boundary Roughness
MUDCLAST	2	N		No. of Mud Clasts
CLASTDIA	4	N	2	Mud Clast Diameter
CLASTSTA	26	C		Mud Clast Status
REDOXDEP	17	C		Mean Redox Depth
REBOUND	5	N	2	Rebound Redox Depth
BUBBLES	2	N		No. of Methane Bubbles
LOWOX	3	C		Low O ₂ Levels
METHAREA	4	N	2	Area of Methane
METHRNG	4	N	1	Avg. Depth Range of Methane
THICK	5	N		Dredged Material Layer
MISCVAL	5	N	2	Miscellaneous Value
MISCLBL	5	C		Miscellaneous Label
COMMENT	58	C		Comment
SUCSTAGE	18	C		Succesional Stage
BENTHDX	13	C		Benthic Index



The grain size file utilizes a separate item to store each parameter measured in a sample since the number of parameters per sample is constant. The fourth file contains data on dredged material source, site, volume and date of disposal. The fifth data file includes data generated from REMOTS surveys. Additional files are being developed to contain such information as replicate survey data, Mussel Watch chemical concentration data, and physical oceanography data.

2.1.3 Parameter File

The parameter files are used to identify the parameter codes present in the data files. An entry in a parameter file contains the parameter code, the parameter name, and other ancillary information describing the parameter. A parameter file offers several advantages in addition to efficient use of storage space for the corresponding data files. Parameter files ensure consistent spelling of the parameter name. Changes in a parameter name are confined to the parameter file thus eliminating the need to search for all occurrences of a changed parameter in the data file. Another advantage is that the parameter name does not have to be stored on each observation in the data file.

There are currently two parameter files in the DAMOS PDB (Table V-2-3). The taxonomic parameter file contains the working code, the taxonomic name and the National Oceanographic Data Center (NODC) hierarchical taxonomic code of the organisms collected in the benthic samples. In a similar manner, the chemical parameter file contains the working code, name and Chemical Abstract Service (CAS) code of the substances measured in the chemical data files. Based on input of benthic data acquired from the historic sources and DAMOS cruises, 152 species have been inserted at this time. As more samples are analyzed from different locations, additional species will be added as necessary.

2.1.4 Documentation and Quality Control Files

The purpose of these files will be to provide documentation of the methods employed in the collection and processing of the cruise samples. Equipment descriptions and methodology summaries are examples of the type of information to be presented in the files.

2.2 Implementing the DAMOS PDB

Both computerized and raw (uncomputerized) data have been incorporated into the DAMOS PDB. Reformatting of the computerized data was done on the SAIC VAX 11/780 and using an Apple II computer with reformatting techniques programmed at SAIC.

The historical (non-DAMOS) data were not recorded in a consistent manner from one study to another. These differences

Table V-2-3

Structure of the DAMOS Parameter Files

PARAMETER FILES

FILE NAME: TAXA_LIST

<u>Name</u>	<u>Width</u>	<u>Type</u>	<u>Decimal Places</u>	<u>Comments</u>
TAXA_CODE	10	I		Parameter Code
SPECIES	32	C		Taxonomic Name
NODC_CODE	10	C		NODC Taxonomic Code
GROUP	8	C		Taxonomic Group

FILE NAME: CHEM_LIST

<u>Name</u>	<u>Width</u>	<u>Type</u>	<u>Decimal Places</u>	<u>Comments</u>
CHEMCODE	6	C		Parameter Code
NAME	40	C		Chemical Name
CASCODE	12	C		CAS Code



included things such as the form of the data (raw vs. computerized), the types of information recorded, the design of the data recording forms, and the types of parameter codes and station identifiers used. The degree of inconsistency from one study to another determined the amount of effort required to develop software for entry of data into the system and for data reformatting, as well as the effort required to standardize parameter and station codes.

2.2.1 Computerized Data

The first step in incorporating computerized data is to make a reconnaissance pass through the data set to verify the file structure and generate matrices which show the spatial and temporal extent of the data. The matrices are compared with published reports to ensure that the correct number and types of samples are present. The matrices also help identify problems in the sample identifiers such as erroneous dates and station codes, and eventually form the basis of cross-referencing tables which link the original sample identifiers with those utilized in the PDB.

One of the most demanding tasks encountered in integrating data from numerous sources involves standardization of parameter names and measurement units. This is especially true for taxonomic data in which there may be inconsistencies among the various studies. It must be understood that some taxonomic inconsistencies in the historical data may never be reconciled. To aid in standardizing the nomenclature, a list of taxonomic and chemical names are extracted from the data and reviewed by the appropriate principal investigator to insure the accuracy of the nomenclature. The lists are also used to build a cross reference table which maps the original parameter names to the appropriate entry in the PDB parameter file.

The final step involved reformatting the computerized data into a form compatible with the structure of the DAMOS PDB. This process involves separating the original data into inventory, data and parameter files, accessing the cross-reference tables to find the new sample identifiers and parameter codes, and writing new files which can be loaded into the PDB. Once the historical data was incorporated into the PDB, the data was compared with the appropriate published reports to ensure the integrity of the data. If major or noteworthy discrepancies existed between the computerized data and the reports, an attempt was made to pinpoint the source and extent of the problem. If the cause of the discrepancies were determined, the data in the PDB was modified accordingly.

2.2.2 Raw Data

Non-computerized data reside on data sheets or as tables and listings in reports. Each type of data sheet was evaluated with regard to its utility in data entry. Tabular data was hand coded onto appropriate data sheets if necessary to facilitate efficient computer entry.

The non-computerized data was entered into temporary files by a "key-to-disc" entry system which employs an interactive computer program to display a blank data form on the CRT terminal. There are several advantages in using an interactive program to enter the data. First, since the program formats the data, errors due to mispositioned numbers (as on cards) are virtually eliminated. Second, the program can automatically duplicate the contents of fields which are the same across several records.

After the data had been computerized, they were subjected to a series of additional quality control checks to minimize the likelihood of errors. Verification listings were generated and compared against the original data sheets. Lists of sample identifiers and parameter names will also be generated and reviewed for accuracy and completeness. The parameter lists were sent to the appropriate experts for review. These lists are especially useful for taxonomic data where misspellings and synonymies are likely to occur.

Any errors identified during the quality control check were corrected using the full-screen data entry software to access the appropriate records and make the required changes. Following final correction, the data are transferred to the NED for loading into the PDB.

2.3 Transfer of Data to NED

Once the data, raw or computerized, is properly formatted, verified and corrected, it is ready for transfer to the HARRIS computer at NED. This is accomplished either on 9-track magnetic tape or directly via modem and phone line. The files are transferred as sequential text files. Once in the HARRIS, the data is incorporated into the INFO system and added to the existing data. As more samples are collected on subsequent cruises, the data is input into the SAIC computer, verified and sent to the HARRIS computer to update the INFO files.

2.4 Retrieval of Data

The first stage in developing software to retrieve data from the DAMOS Project Data Base is to allow the user to connect to the HARRIS computer via modem and run a program to access the INFO system. Once initialized, the program will display a series of questions and choices to the user. The user may view the entire inventory of data files available, although this could consume much time and money, or the user can set criteria by which the program may create a subset of data. The user will be asked to specify time periods, locations and data types in response to the displayed possible choices for each.

Once the subset of requested data has been created, the data may be viewed and/or downloaded to the user's computer. The user may then manipulate and analyze the data using software

packages available for his specific computer system.

At present, IBM PC's have been used to download data for use with Lotus 1-2-3 software. Additionally, data has been used with word processing software packages such as Wordstar and Displaywrite 3.

