

Variable displacement pump A10VSO

RE 92 711/10.07 1/40
Replaces: 09.00

open circuit

Size 28...140
Series 31
Nominal pressure 280 bar
Peak pressure 350 bar

Contents

Ordering Code / Standard Program	2, 3
Fluid, Mechanical Displacement Limiter, High-Speed-Version	4
Technical Data	5
Installation Notes	6
Noise Characteristics	7
Drive Power and Flow	8, 9
Unit Dimensions, Size 28	10
Unit Dimensions, Size 45	11
Unit Dimensions, Size 71	12
Unit Dimensions, Size 100	13
Unit Dimensions, Size 140	14
Two-position Adjustment Direct Control DG	15
Pressure Control DR	16, 17
Pressure Control, Remote Controlled DRG	18, 19
Pressure / Flow Control DFR	20, 21
Pressure / Flow / Power Control DFLR	22, 23
Flow Control, Pilot Pressure-dependent FHD	24, 25
Through Drives	26
Unit Dimensions Combination Pumps	27
Unit Dimensions Through Drives KB2, K51, KB3 und K25	28, 29
Unit Dimensions Through Drives KB4, K26, KB5 und K27	30, 31
Unit Dimensions Through Drives KB6, K37, KB7 und K59	32, 33
Unit Dimensions Through Drives K01, K52, K02 und K68	34, 35
Unit Dimensions Through Drives K04, K07, K24 und K17	36, 37
Unit Dimensions Through Drive K57	38
Preferred Types	39

Features

- Variable displacement axial piston pump of swashplate design for hydrostatic open circuit systems
- Flow is proportional to drive speed and displacement. It can be infinitely varied by adjustment of the swashplate.
- ISO mounting flange
- Flange connections to SAE metric
- 2 case drain ports
- Good suction characteristics
- Permissible continuous pressure 280 bar
- Low noise level
- Long service life
- Axial and radial loading of drive shaft possible
- High power-weight ratio
- Wide range of controls
- Short response times
- Through drive option for multi-circuit system
- Further information:
Variable Displacement Pump A10VSO RE 92 712
Size 18

Ordering Code / Standard Program

Hydraulic Fluid / Type

28...100 140

Mineral oil and HFD (no prefix)	●	●	
HFA, HFB and HFC - Fluids (with the exception of Skydrol)	●	●	E
High-Speed-Version	–	●	H

Axial Piston Unit

Variable swashplate design, for industrial applications **A10VS**
 Nominal pressure 280 bar, peak pressure 350 bar

Type of operation

Pump in open circuit **0**

Size

≙ Displacement $V_{g \max}$ (cm³)

28	45	71*	100	140
----	----	-----	-----	-----

Control device

28 45 71 100 140

Two-position control, direct operated	DG			●	●	●	●	●	DG
Pressure control	DR			●	●	●	●	●	DR
	DR	G		●	●	●	●	●	DRG
remotely controlled									
Pressure/flow control	DFR			●	●	●	●	●	DFR
	DFR	1		●	●	●	●	●	DFR1
without orifice in X-line									
Pressure/flow/power control				●	●	●	●	●	DFLR
Flow control, pilot pressure dependent with pressure control				●	●	●	●	●	FHD
Flow control, electronic				●	●	●	●	○	FE1**
Pressure/flow control, electronic				●	●	●	●	●	DFE1**
Elektro-hydraulic pressure control				●	●	●	○	○	ED

see RE 92 707
(in preparation)

** For further control information see RE 30 022

Series

31

Direction of rotation

Viewed on shaft end

clockwise	R
anti clockwise	L

Seals

NBR nitril-caoutchouc to DIN ISO 1629 (shaft seal in FKM)	P
FKM fluor-caoutchouc to DIN ISO 1629	V

Shaft end

28 45 71 100 140

Parallel with key DIN 6885	●	●	●	●	●	P
Splined shaft SAE	7/8"	1"	1 1/4"	1 1/2"	1 3/4"	S
Splined shaft SAE (higher through drive torque)	7/8"	1"	1 1/4"	–	–	R

* Project note for size 71

Pressure port B consists of a high pressure combination port
SAE 11/4" standard pressure range, 3000 psi, **for pressures up to 250 bar**
SAE 1" standard pressure range, 5000 psi, **for pressures in excess of 250 bar** (see page 12).
 For **new applications high pressure port SAE 1"** must be used.

preferred program
(short delivery times)
see list on page 39

● = available
○ = in preparation
– = not available

Technical Data

Hydraulic fluid

For extensive information on the range of fluids and application conditions please see our data sheet RE 90220 (mineral oils), RE 90221 (environmentally acceptable fluids) and RE 90223 (HF-fire resistant hydraulic fluids).

When using HF- or environmentally acceptable hydraulic fluids possible limitations for the technical data have to be taken into consideration. If necessary please consult our technical department (please indicate type of the hydraulic fluid used for your application on the order sheet).

Operation on Skydrol hydraulic fluid is subject to consultation.

Operating viscosity range

In order to obtain optimum efficiency and service life, we recommend that the operating viscosity (at operating temperature) be selected from within the range

$$v_{\text{opt}} = \text{operating viscosity } 16 \dots 36 \text{ mm}^2/\text{s}$$

referred to the reservoir temperature (open circuit).

Viscosity limits

The limiting values for viscosity are as follows:

$$v_{\text{min}} = 10 \text{ mm}^2/\text{s}$$

short term at a max. permissible case temp. of 90° C.

$$v_{\text{max}} = 1000 \text{ mm}^2/\text{s}$$

short term on cold start.

Temperature range (see selection diagram)

$$t_{\text{min}} = -25^\circ \text{ C}$$

$$t_{\text{max}} = 90^\circ \text{ C}$$

Selection diagram

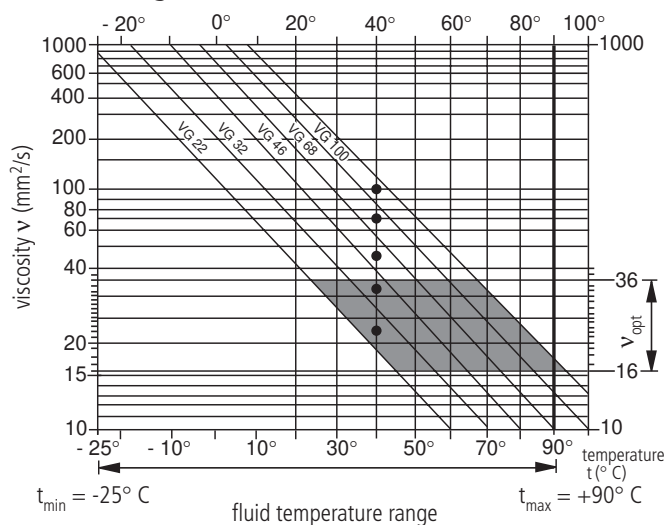

Notes on the selection of the hydraulic fluid

In order to select the correct fluid, it is necessary to know the operating temperature in the tank (open loop) in relation to the ambient temperature.

The hydraulic fluid should be selected so that within the operating temperature range, the operating viscosity lies within the optimum range (v_{opt}) (see shaded section of the selection diagram). We recommend that the higher viscosity range should be chosen in each case.

Example: At an ambient temperature of X° C the operating temperature is 60° C. Within the operating viscosity range (v_{opt} ; shaded area), this corresponds to viscosity ranges VG 46 or VG 68; VG 68 should be selected.

Important: The leakage oil (case drain oil) temperature is influenced by pressure and pump speed and is always higher than the tank temperature. However, at no point in the circuit may the temperature exceed 90° C.

If it is not possible to comply with the above conditions because of extreme operating parameters or high ambient temperatures please consult us.

Filtration

The finer the filtration the better the cleanliness of the pressure fluid and the longer the life of the axial piston unit.

To ensure the functioning of the axial piston unit a minimum cleanliness level of:

9 to NAS 1638

18/15 to ISO/DIS 4406 is necessary.

If above mentioned grades cannot be maintained please consult supplier.

High-speed-version

The size 140 is available in an optional high speed version. This version allows higher drive speeds at max. displacement (higher output flow) without affecting outside dimensions, see table on page 5.

Mechanical displacement limiter

Mechanical displacement limiter **is possible on the nonthrough-drive model, N00 series** but **not** for the model **with through-drive**.

Exception: with FE1-, FE1D- and DFE1 control a max. displacement screw is not possible at all.

$V_{g \text{ max}}$: for sizes 28 to 140
Setting range $V_{g \text{ max}}$ to 50% $V_{g \text{ max}}$ stepless

$V_{g \text{ min}}$: for sizes 100 and 140
Setting range $V_{g \text{ min}}$ to 50% $V_{g \text{ max}}$ stepless

Technical Data

(valid for operation on mineral oil; for **HF-fluids** see RE 90223 and **environmentally acceptable hydraulic fluids** see RE 90221)

Operating pressure range - inlet

Absolute pressure at port S

$p_{abs \text{ min}}$ _____ 0,8 bar
 $p_{abs \text{ max}}$ _____ 30 bar

Operating pressure range - outlet

Pressure at port B

Nominal pressure p_N _____ 280 bar
 Peak pressure p_{max} _____ 350 bar
 (Pressure data to DIN 24312)

Limitation of pump output pressure spikes is possible with relief valve blocks mounted directly on flange connection, acc. to data sheets RE 25 880 and RE 25 890 to be ordered separately.

Case drain pressure

Maximum permissible pressure of leakage fluid (at port L, L_1):
 Maximum 0,5 bar higher than the inlet pressure at port S, but no higher than 2 bar absolute.

Direction of through flow

S to B.

Determination of inlet pressure p_{abs} at suction port S or reduction of displacement for increasing speed.

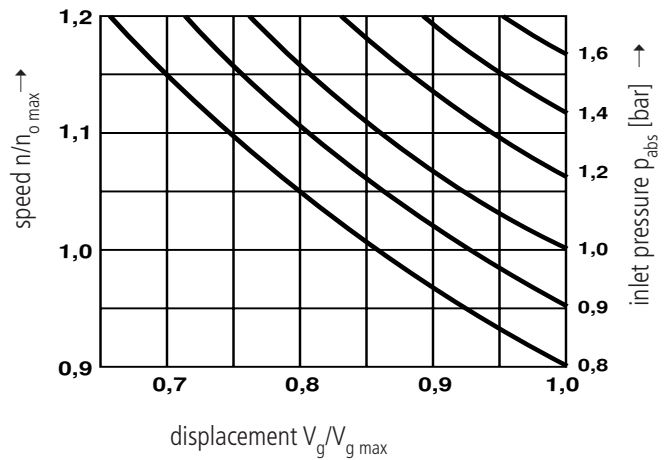

Table of values (theoretical values, without taking into account η_{mh} and η_v : values rounded off)

Size			28	45	71	100	140/High-S*	
Displacement	$V_{g \text{ max}}$	cm ³	28	45	71	100	140/140	
Max. speed ¹⁾	at $V_{g \text{ max}}$	$n_{o \text{ max}}$	rpm	3000	2600	2200	2000	1800/2050
Max. permitted speed (limit speed) with increased input pressure p_{abs} bzw. $V_g < V_{g \text{ max}}$		$n_{o \text{ max}}$	rpm	3600	3100	2600	2400	2100/2200
Max. flow	at $n_{o \text{ max}}$	$q_{vo \text{ max}}$	L/min	84	117	156	200	252/287
	at $n_E = 1500 \text{ min}^{-1}$		L/min	42	68	107	150	210
Max. power ($\Delta p = 280 \text{ bar}$)	at $n_{o \text{ max}}$	$P_{o \text{ max}}$	kW	39	55	73	93	118/134
	at $n_E = 1500 \text{ min}^{-1}$		kW	20	32	50	70	98
Max. torque ($\Delta p = 280 \text{ bar}$)	at $V_{g \text{ max}}$	T_{max}	Nm	125	200	316	445	623
Torque ($\Delta p = 100 \text{ bar}$)	at $V_{g \text{ max}}$	T	Nm	45	72	113	159	223
Moment of inertia about drive axis		J	kgm ²	0,0017	0,0033	0,0083	0,0167	0,0242
Case volume		L		0,7	1,0	1,6	2,2	3,0
Weight (without fluid)		m	kg	15	21	33	45	60
Permissible loading of drive shaft:	max. axial force	$F_{ax \text{ max}}$	N	1000	1500	2400	4000	4800
Max. permissible radial force ²⁾		$F_{q \text{ max}}$	N	1200	1500	1900	2300	2800

* = High-Speed-Version

application of forces

¹⁾ These values are valid for an absolute pressure of 1 bar at the suction port S. By reducing the displacement or increasing the input pressure the speed can be increased as shown in the diagram.

²⁾ Please consult us for higher radial forces.

Determination of displacement

Flow $q_v = \frac{V_g \cdot n \cdot \eta_v}{1000}$ [L/min]

Torque $T = \frac{1,59 \cdot V_g \cdot \Delta p}{100 \cdot \eta_{mh}} = \frac{V_g \cdot \Delta p}{20 \cdot \pi \cdot \eta_{mh}}$ [Nm]

Power $P = \frac{T \cdot n}{9549} = \frac{2 \pi \cdot T \cdot n}{60 \cdot 1000} = \frac{q_v \cdot \Delta p}{600 \cdot \eta_t}$ [kW]

V_g = displacement [cm³] per revolution

Δp = pressure differential [bar]

n = speed [rpm]

η_v = volumetric efficiency

η_{mh} = mechanical-hydraulic efficiency

η_t = overall efficiency ($\eta_t = \eta_v \cdot \eta_{mh}$)

Installation Notes

Optional installation position. The pump housing must be filled with fluid during commissioning and remain full when operating.

In order to attain the lowest noise level, all connections (suction, pressure, case drain ports) must be linked by flexible couplings to tank.

Avoid placing a check valve in the case drain line.

This may, however, be permissible in individual cases, after consultation with us.

1. Vertical installation (shaft end upwards)

The following installation conditions must be taken into account:

1.1. Arrangement in the reservoir

Before installation fill pump housing, keeping it in a horizontal position.

a) If the minimum fluid level is equal to or above the pump mounting face close port "L" plugged, leave ports "L₁" and "S" open; L₁ piped and recommendation S piped (see Fig.1).

b) If the minimum fluid level is below the pump mounting face pipe port "L₁" and "S" according to Fig. 2.

Close port "L" with respect taking into consideration conditions in 1.2.1.

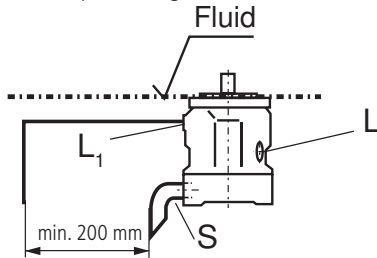

Fig. 1

1.2. Arrangement outside the reservoir

Before installation fill the pump housing, keeping it in a horizontal position. For mounting above reservoir see Fig. 2.

Limiting condition:

1.2.1. Minimum pump inlet pressure $p_{abs\ min} = 0.8\ bar$ under both static and dynamic conditions.

Note: Avoid mounting above reservoir wherever possible in order to achieve a low noise level.

The permissible suction height h comes from the overall pressure loss, but may not be bigger than $h_{max} = 800\ mm$ (immersion depth $h_{t\ min} = 200\ mm$).

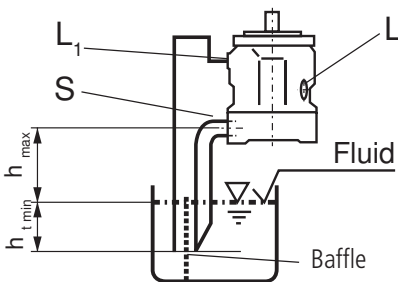

Fig. 2

Overall pressure loss $\Delta p_{tot} = \Delta p_1 + \Delta p_2 + \Delta p_3 \leq (1 - p_{abs\ min}) = 0.2\ bar$

Δp_1 : Pressure loss in pipe due to accelerating column of fluid

$$\Delta p_1 = \frac{\rho \cdot l \cdot dv}{dt} \cdot 10^{-5} \text{ (bar)}$$

ρ = density (kg/m³)
 l = pipe length (m)
 dv/dt = rate of change in fluid velocity (m/s²)

Δp_2 : Pressure loss due to static head

$$\Delta p_2 = h \cdot \rho \cdot g \cdot 10^{-5} \text{ (bar)}$$

h = height (m)
 ρ = density (kg/m³)
 g = gravity = 9.81 m/s²

Δp_3 : Line losses (elbows etc.)

2. Horizontal installation

The pump must be installed, so that "L" or "L₁" is at the top.

2.1. Arrangement in the reservoir

a) If the minimum fluid level is above the top of the pump, port "L₁" closed, "L" and "S" should remain open, L piped and recommendation S piped (see Fig. 3)

b) If the minimum fluid level is equal to or below the top of the pump, pipe ports "L" and possibly "S" as Fig. 4.; close port "L₁". The conditions according to item 1.2.1.

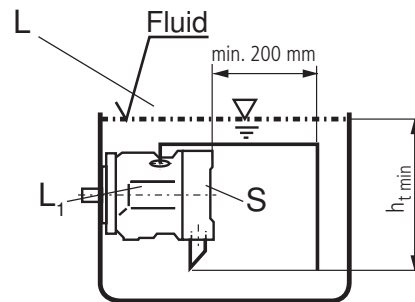

Fig. 3

2.2. Installation outside the reservoir

Fill the pump housing before commissioning.

Pipe ports "S" and the higher port "L" or "L₁".

a) When mounting above the reservoir, see Fig. 4.

Conditions according to 1.2.1.

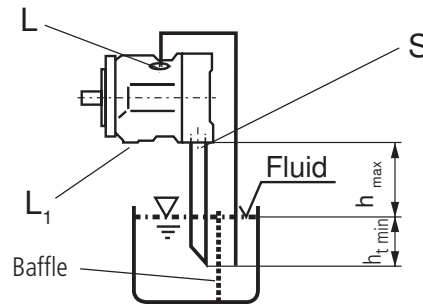

Fig. 4

b) Mounting below the reservoir

Pipe ports "L₁" and "S" according to Fig.5, close port "L".

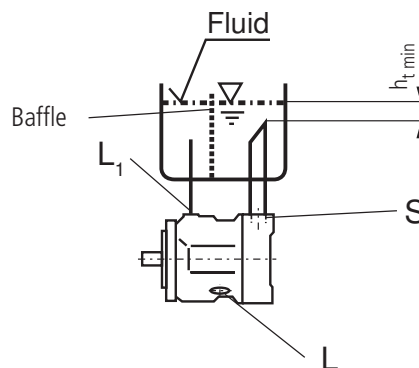

Fig. 5

Performance Curves for Pump with Pressure Control DR

Noise level

Measured in an anechoic chamber

Distance from microphone to pump = 1 m

Measuring error: ± 2 dB (A)

(Fluid: Hydraulic oil to ISO VG 46 DIN 51519, $t = 50^\circ$ C)

Size 28

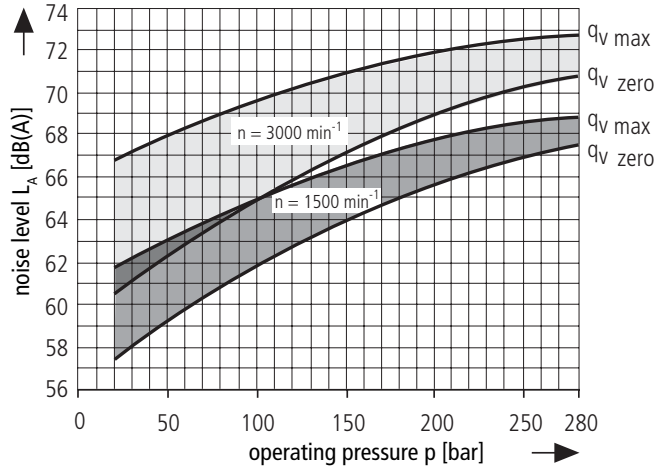

Size 100

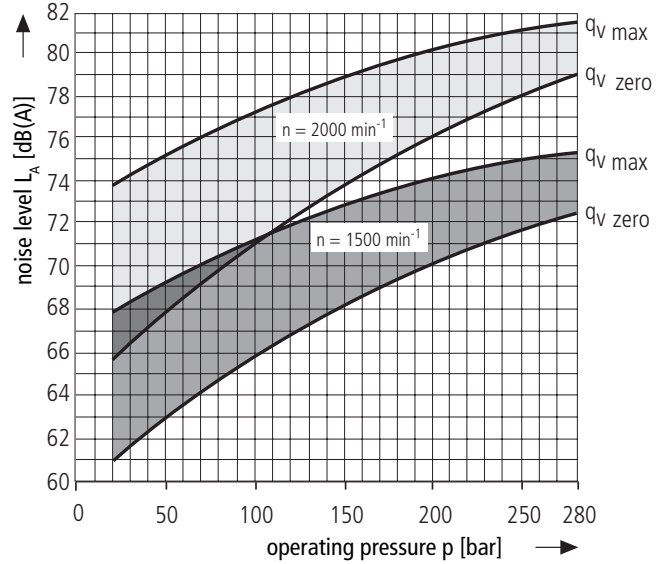

Size 45

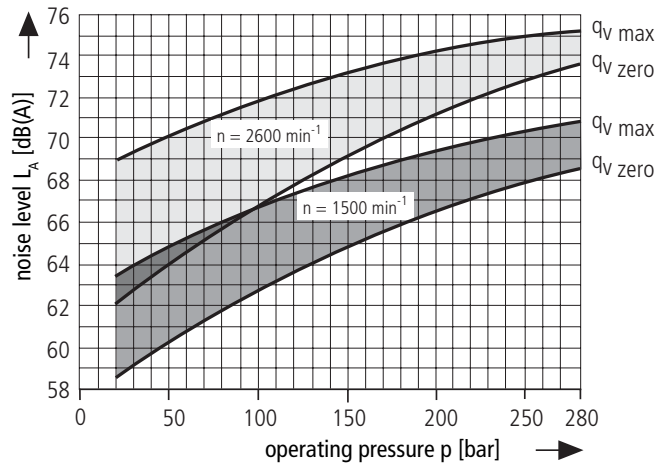

Size 140

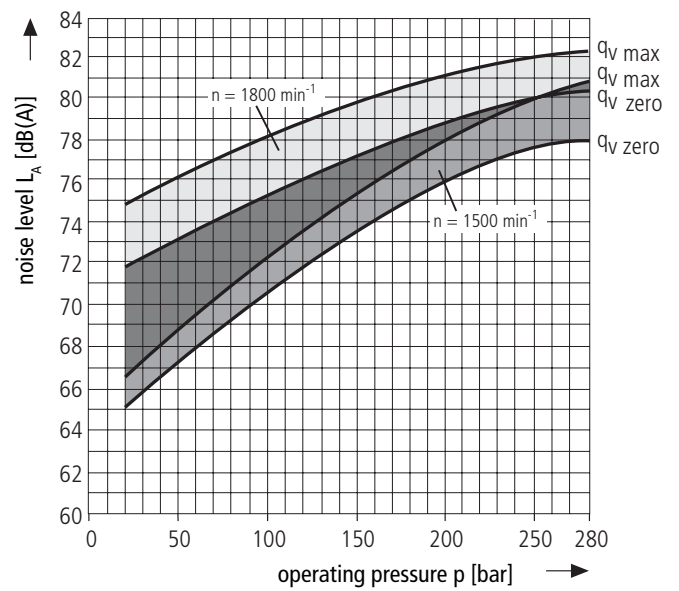

Size 71

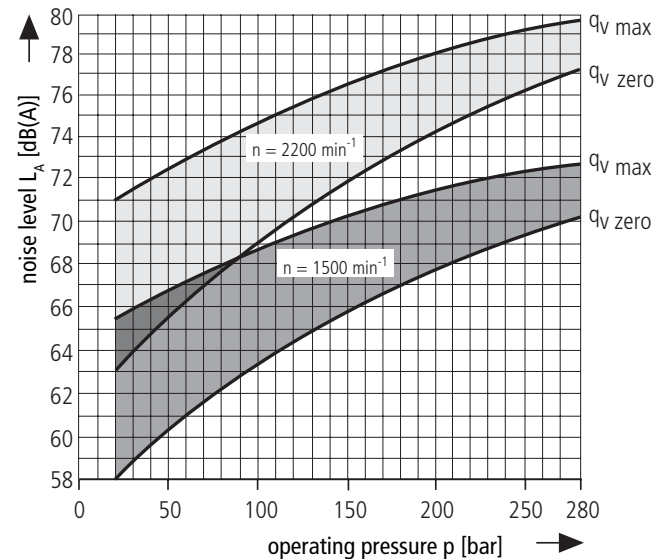

Drive Power and Output Flow

(Fluid: Hydraulic oil ISO VG 46 DIN 51519, $t = 50^\circ \text{C}$)

Size 28

----- $n = 1500 \text{ min}^{-1}$
 ——— $n = 3000 \text{ min}^{-1}$

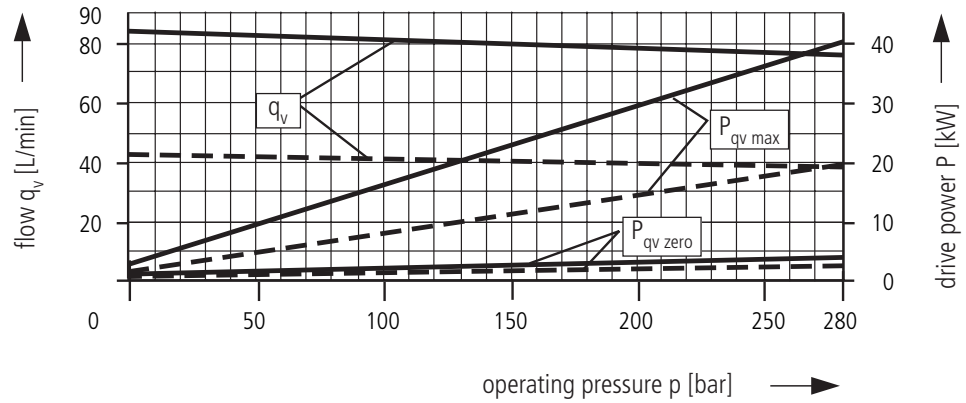

Size 45

----- $n = 1500 \text{ min}^{-1}$
 ——— $n = 2600 \text{ min}^{-1}$

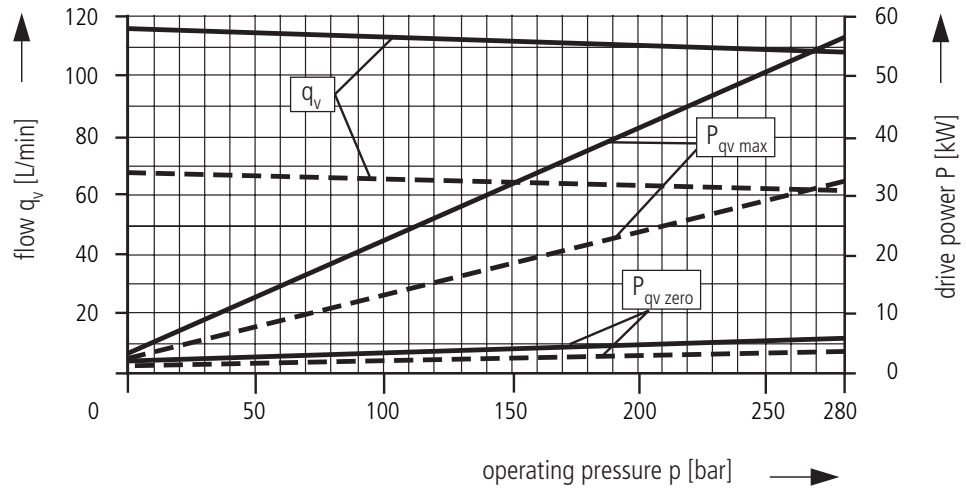

Size 71

----- $n = 1500 \text{ min}^{-1}$
 ——— $n = 2200 \text{ min}^{-1}$

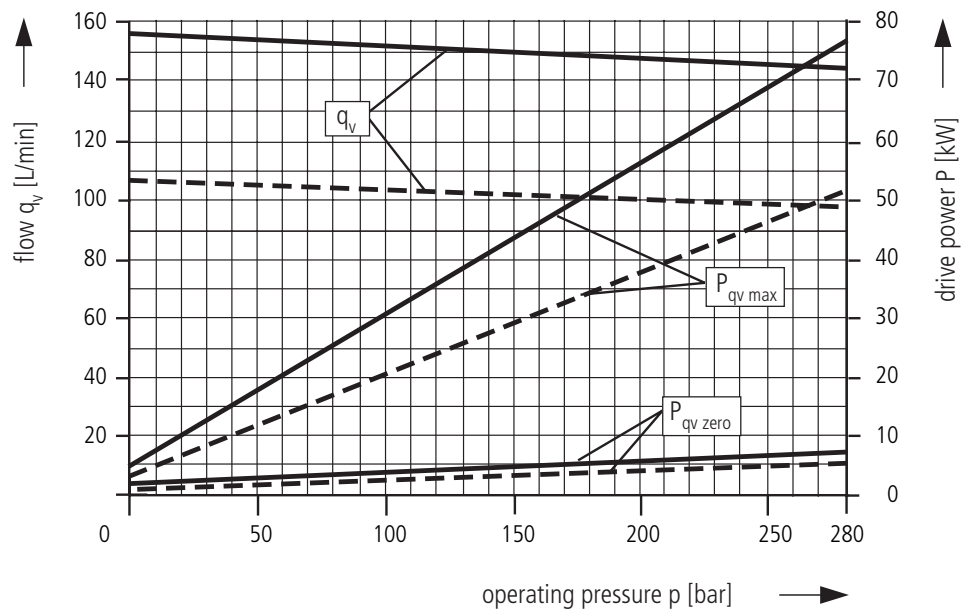

Drive Power and Output Flow

(Fluid: Hydraulic oil ISO VG 46 DIN 51519, $t = 50^\circ\text{C}$)

Size 100

----- $n = 1500\text{ min}^{-1}$
 ———— $n = 2000\text{ min}^{-1}$

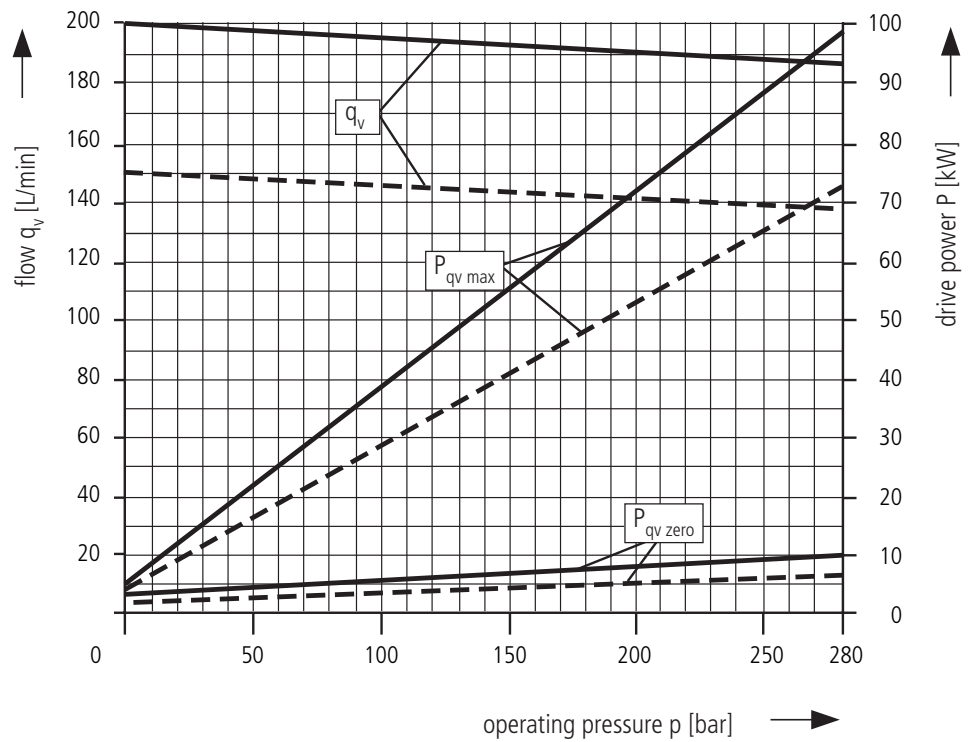

Size 140

----- $n = 1500\text{ min}^{-1}$
 ———— $n = 1800\text{ min}^{-1}$

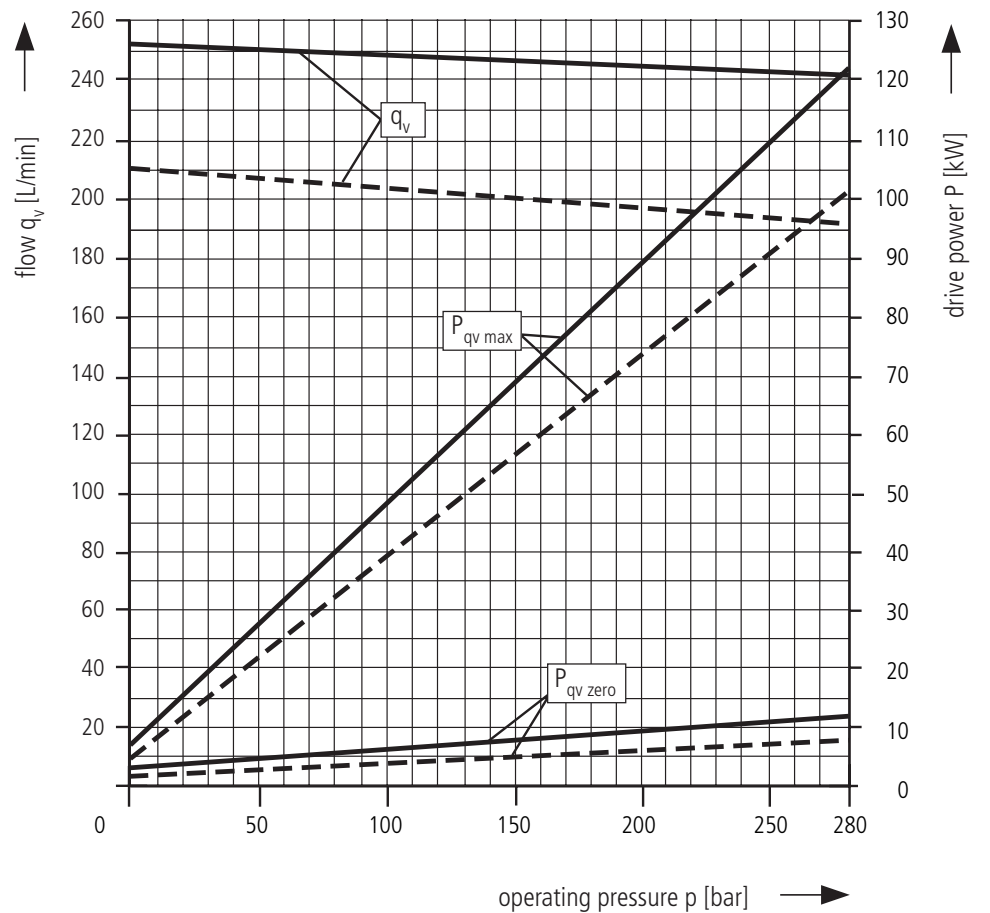

Overall efficiency

$$\eta_t = \frac{q_v \cdot p}{P_{qv\text{ max}} \cdot 600}$$

Volumetric efficiency

$$\eta_v = \frac{q_v}{q_{v\text{ theor.}}}$$

Unit Dimensions Size 28

N00 model (without through drive)

Before finishing your design, please request a certified drawing.

without control valves

Shaft P

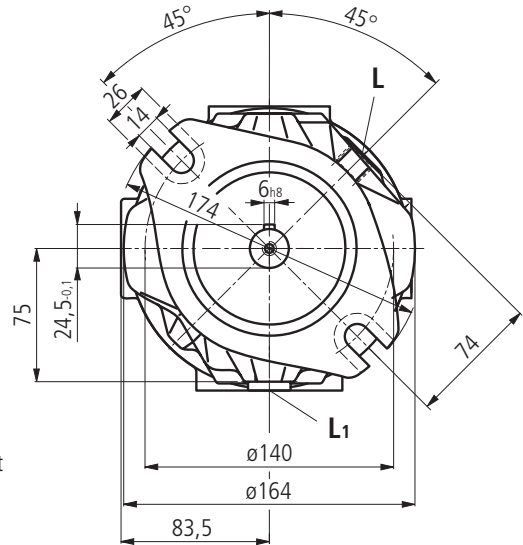
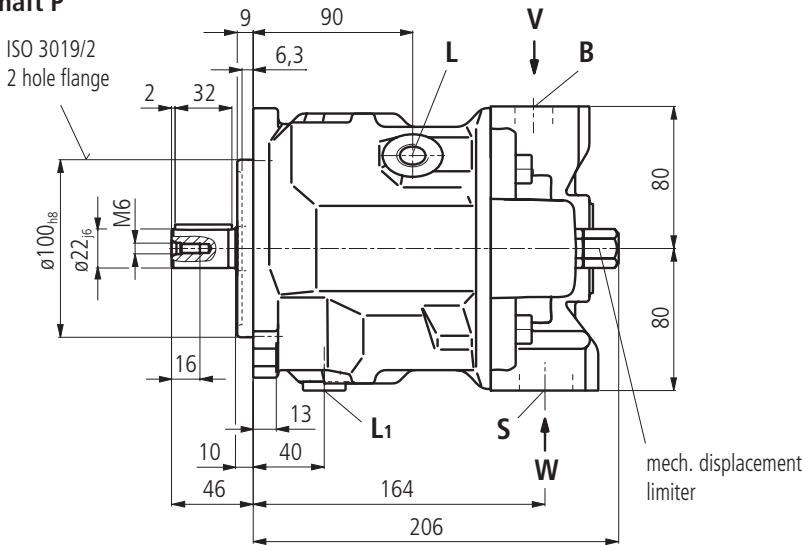

Shaft S

Shaft 22-4; (SAE B)
SAE J744 OCT 83

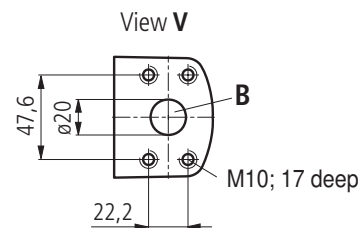
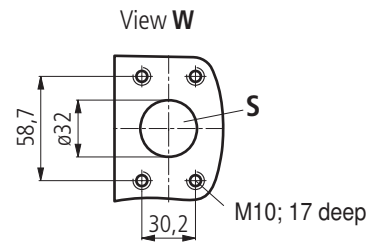
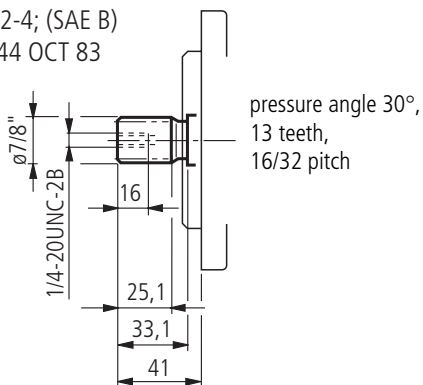

Shaft R

Shaft 22-4; (SAE B)
SAE J744 OCT 83

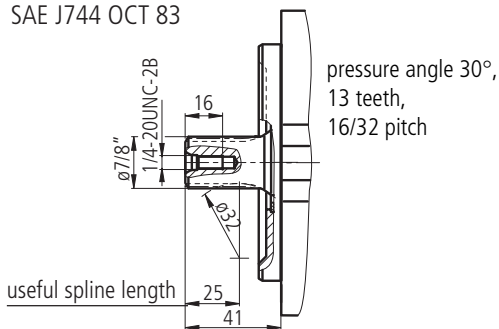

B	Pressure port	SAE 3/4"	(Standard pressure range)
S	Suction port	SAE 1 1/4"	(Standard pressure range)
L/L ₁	Case drain ports	M18x1,5	(L ₁ plugged at factory)

Unit Dimensions Size 45

N00 model (without through drive)

Before finishing your design, please request a certified drawing.

without control valves

Shaft P

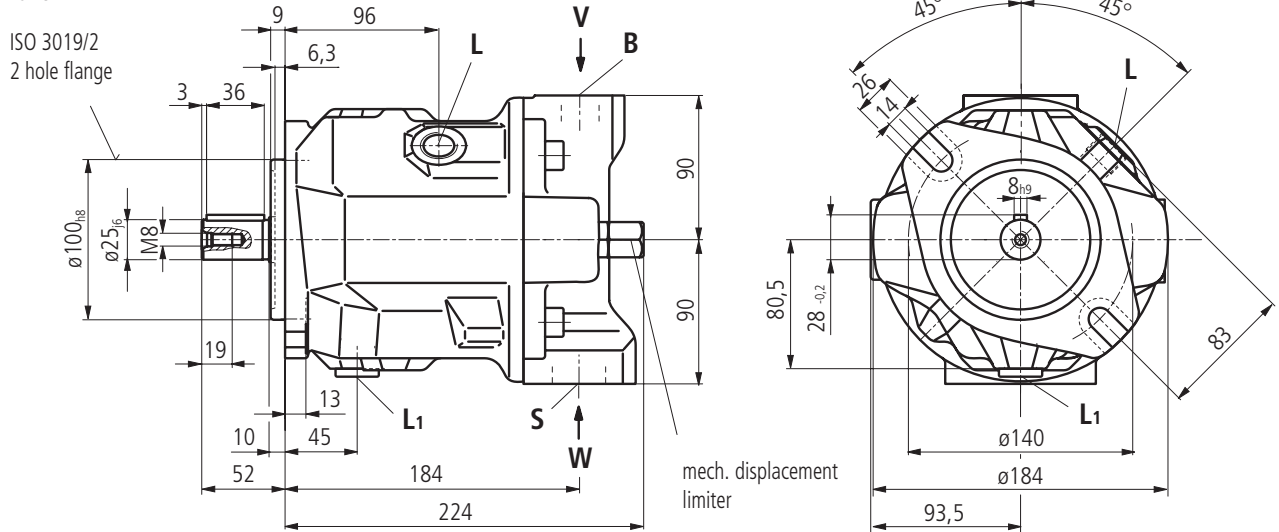

Shaft S

Shaft 25-4; (SAE B-B)
SAE J744 OCT 83

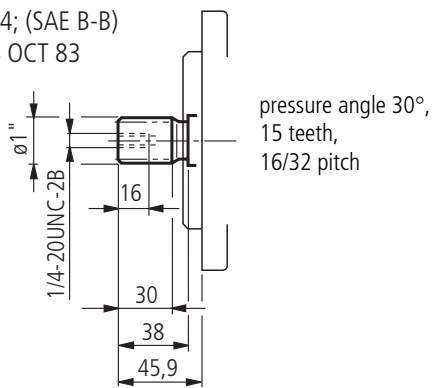

Ansicht W

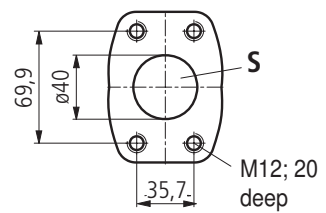

View V

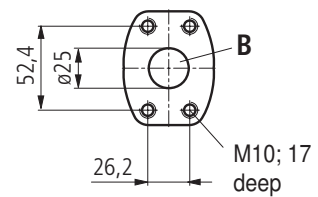

Shaft R

Shaft 25-4; (SAE B-B)
SAE J744 OCT 83

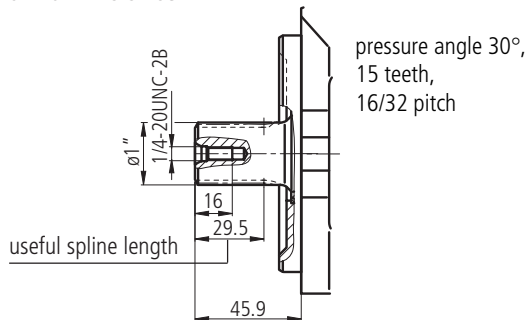

B	Pressure port	SAE 1"	(Standard pressure range)
S	Suction port	SAE 1 1/2"	(Standard pressure range)
L/L ₁	Case drain ports	M22x1,5	(L ₁ plugged at factory)

Unit Dimensions Size 71

N00 model (without through drive)

Before finishing your design, please request a certified drawing.

without control valves

Shaft P

ISO 3019/2
2 hole flange

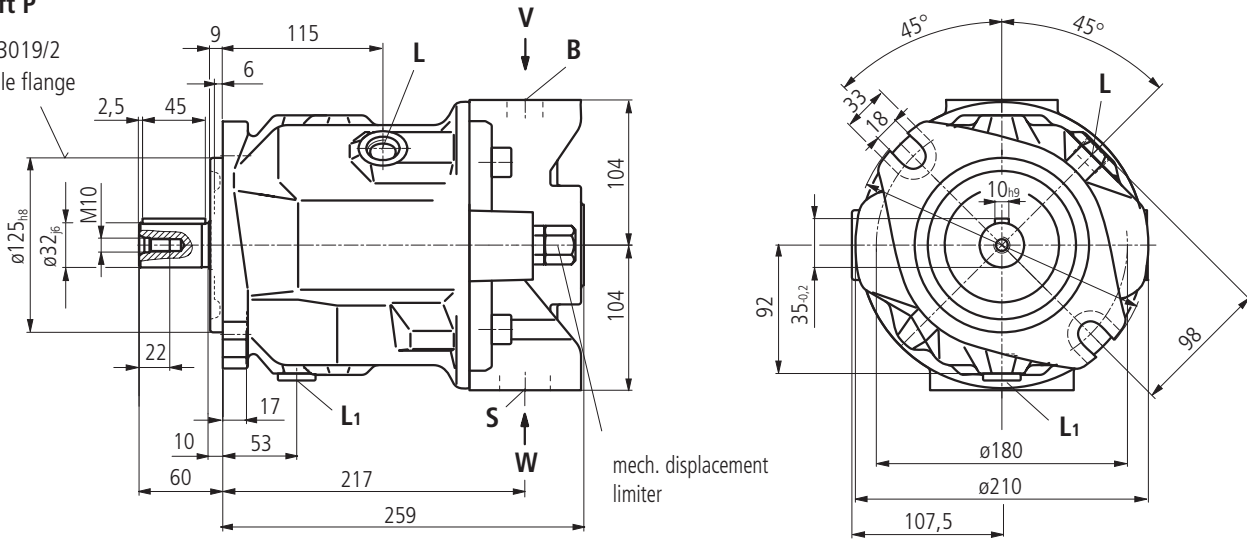

Shaft S

Shaft 32-4; (SAE C)
SAE J744 OCT 83

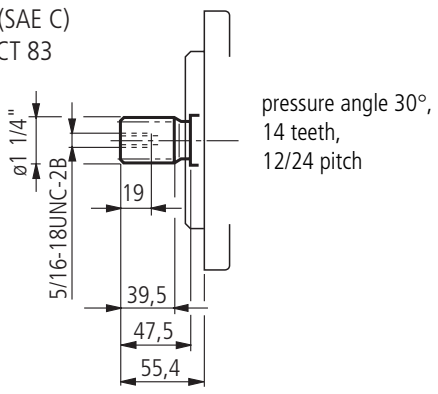

View W

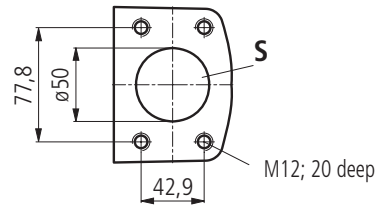

View V

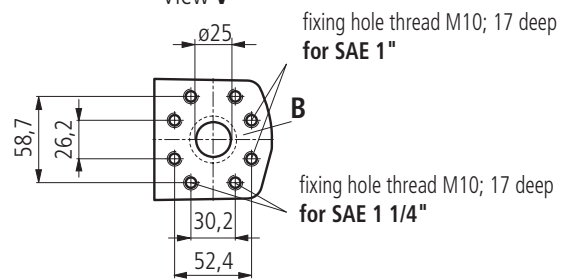

Shaft R

Shaft 32-4; (SAE C)
SAE J744 OCT 83

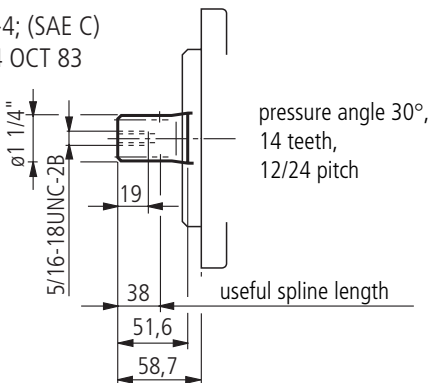

Note:

At **pressure port B** there are two SAE mountings available, each offset by 90°. **SAE 1 1/4"** Standard pressure range, 3000 psi, for pressures **up to 250 bar** or **SAE 1"** Standard pressure range, 5000 psi, for pressures **in excess of 250 bar**. For operating pressures in excess of 250 bar or for new projects an SAE 1" pressure flange should be used.

B	Pressure port	SAE 1"	(Standard pressure range) bolt hole threads to either SAE 1" or SAE 1 1/4" (optional)
S	Suction port	SAE 2"	(Standard pressure range)
L/L ₁	Case drain ports	M22x1,5	(L ₁ plugged at factory)

Unit Dimensions Size 100

N00 model (without through drive)
without control valves

Before finishing your design, please request a certified drawing.

Shaft P

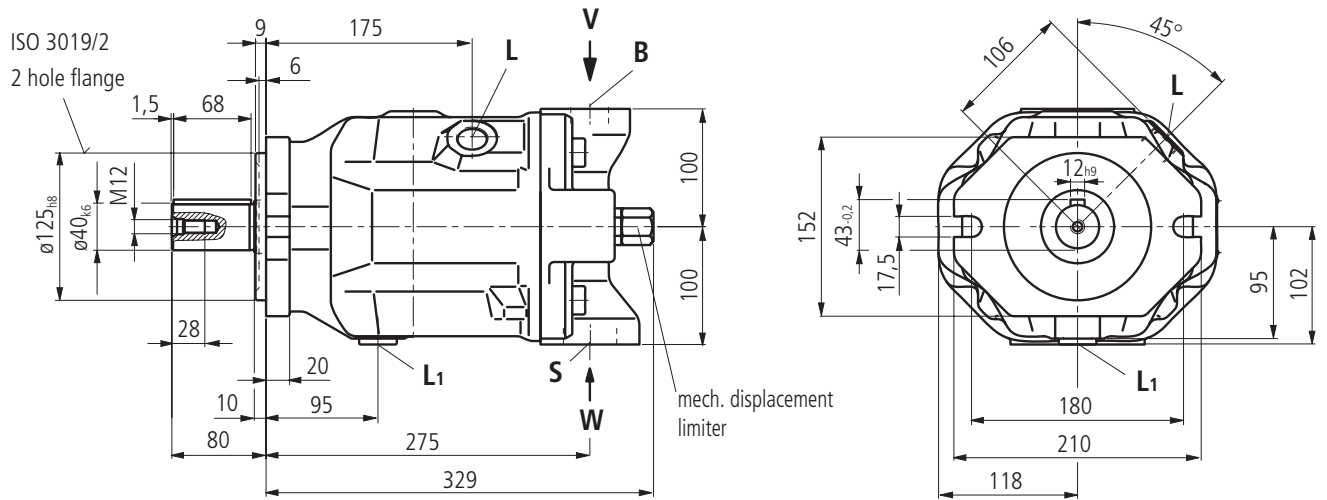

Shaft S

Shaft 38-4; (SAE C-C)
SAE J744 OCT 83

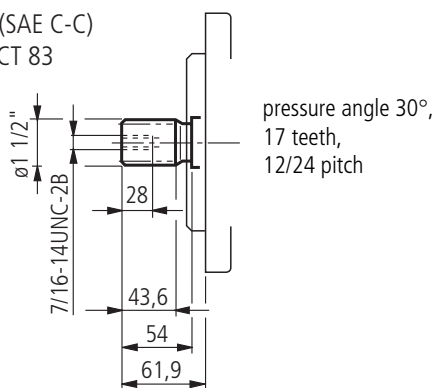

View W

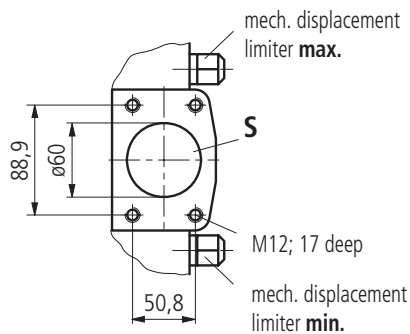

View V

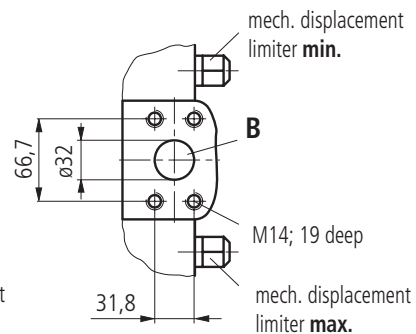

B	Pressure port	SAE 1 1/4"	(High pressure range)
S	Suction port	SAE 2 1/2"	(Standard pressure range)
L/L ₁	Case drain ports	M27x2	(L ₁ plugged at factory)

Unit Dimensions Size 140

N00 model (without through drive)

Before finishing your design, please request a certified drawing.

without control valves

Shaft P

ISO 3019/2
4 hole flange

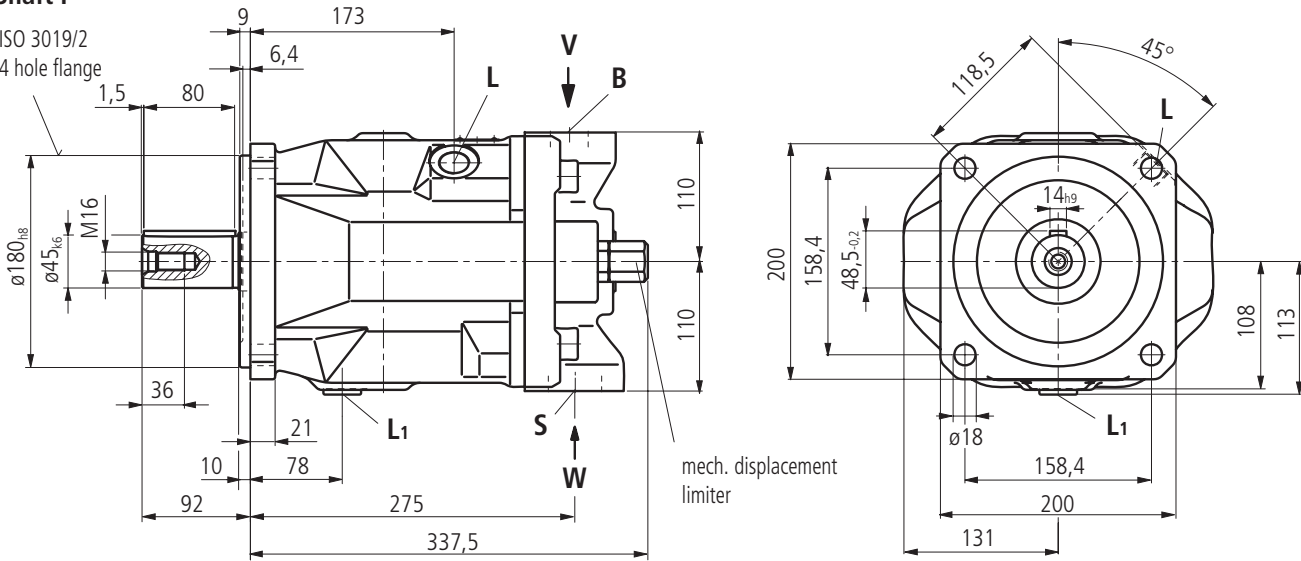

Shaft S

Shaft 44-4; (SAE D)
SAE J744 OCT 83

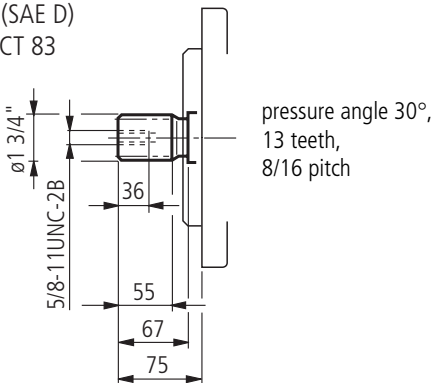

View W

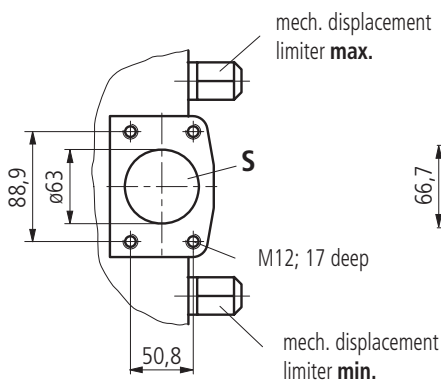

View V

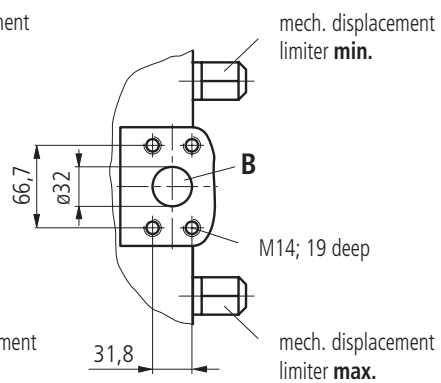

B	Pressure port	SAE 1 1/4"	(High pressure range)
S	Suction port	SAE 2 1/2"	(Standard pressure range)
L/L ₁	Case drain ports	M27x2	(L ₁ plugged at factory)

DG 2-position adjustment, direct control

Before finishing your design, please request a certified drawing.

The pump can be set to a minimum swivel angle by connecting an external switching pressure to port X.

This pressure acts directly onto the control piston, a min. control pressure of at least 30 bar is required.

The pump can only be switched between V_{gmax} and V_{gmin} .

The switching pressure p_{St} depends on pump output pressure at a ratio of 1:4

$$p_{St} = \frac{p}{4}$$

switching pressure p_{St} in X = 0 bar

$$\triangleq V_{gmax}$$

switching pressure p_{St} in X \geq 30 bar or $\frac{p}{4} \triangleq V_{gmin}$

Controller data

min. switching pressure	30 bar
max. switching pressure	280 bar

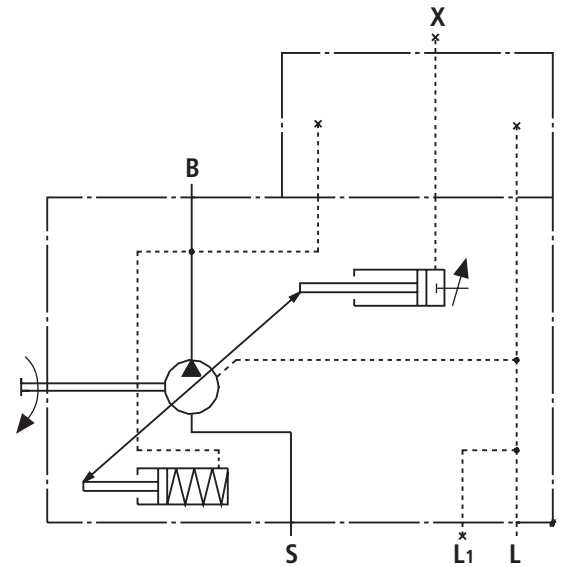

Unit dimensions

Sizes 28...100

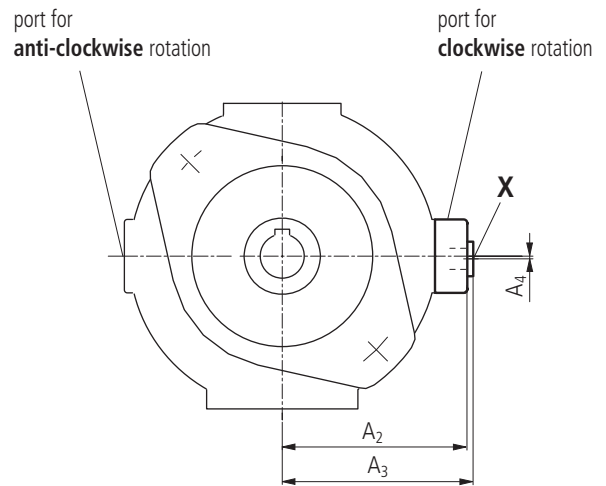
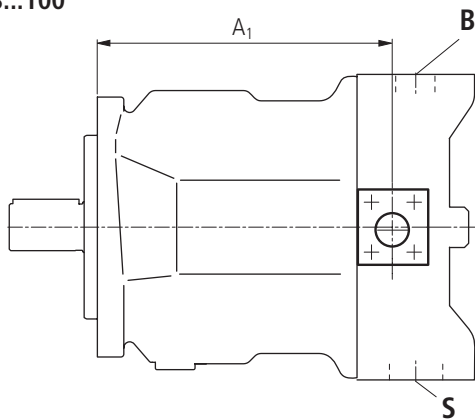

Size 140

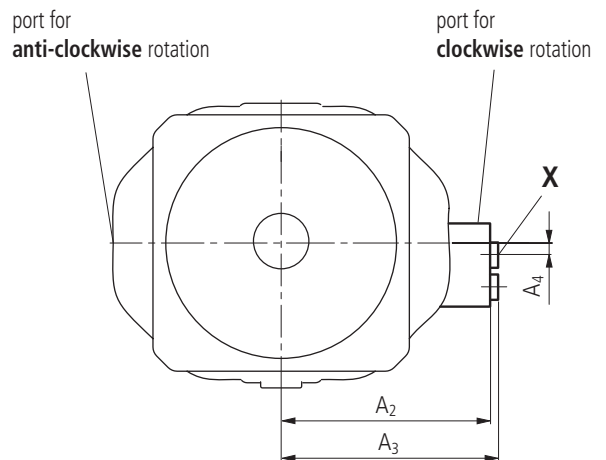
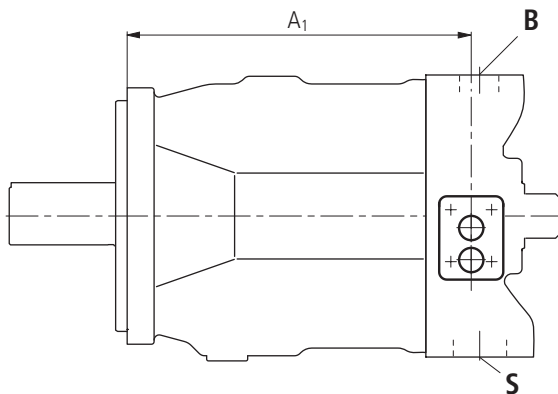

Unit dimensions

Size	A ₁	A ₂	A ₃	A ₄	X (plugged)
28	158	100	103,5	3	R 1/4"
45	173	110	113,5	3	R 1/4"
71	201	123,5	127,5	3	R 1/4"
100	268	128,5	132,5	3	R 1/4"
140	268	153	158	4,6	M14x1,5

Ports

- B** Pressure port
- S** Suction port
- L, L1** Case drain ports (L1 plugged)
- X** Pilot pressure port (plugged)

DR Pressure Control

The pressure controller serves to maintain a constant pressure in a hydraulic system within the control range of the pump. The pump therefore supplies only the amount of hydraulic fluid required by the system. Pressure may be steplessly set at the control valve.

Static operating curve

(at $n_1 = 1500 \text{ rpm}$; $t_{oil} = 50^\circ \text{ C}$)

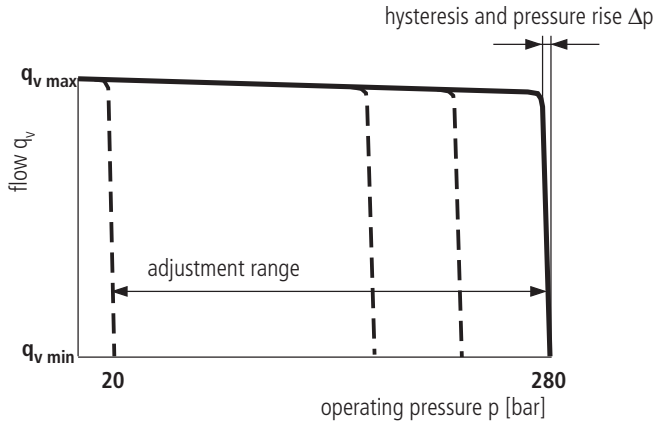

Dynamic operating curves

The operating curves are mean values measured under test conditions with the unit mounted inside the tank.

Conditions: $n = 1500 \text{ rpm}$
 $t_{oil} = 50^\circ \text{ C}$
 Main relief set at 350 bar

Load steps were obtained by suddenly opening and closing the pressure line with a pressure relief valve as load valve 1 m from the output flange of the pump.

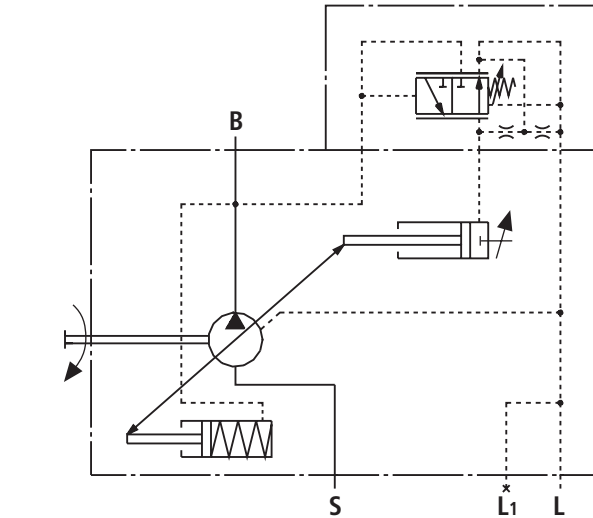
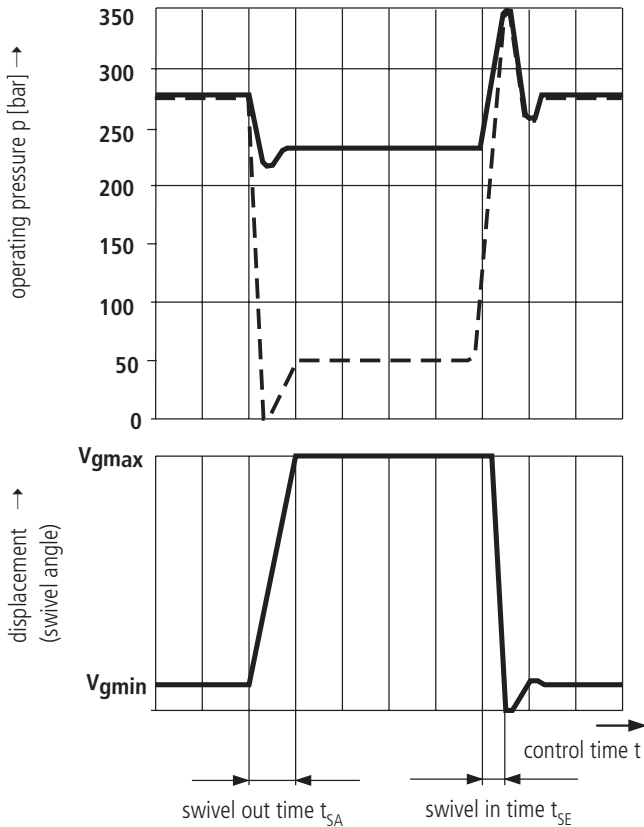

Ports

- B** Pressure port
- S** Suction port
- L, L1** Case drain ports (L1 plugged)

Controller data

Hysteresis and repetitive accuracy Δp _____ max. 3 bar

Max. Pressure rise

Size	28	45	71	100	140
Δp bar	4	6	8	10	12

Pilot oil requirement _____ max. approx 3 L/min

Flow loss at q_{vmax} see pages 8 and 9.

Control times

Size	t_{SA} (ms) against 50 bar	t_{SA} (ms) against 220 bar	t_{SE} (ms) stalled at 280 bar
28	60	30	20
45	80	40	20
71	100	50	25
100	125	90	30
140	130	110	30

Unit Dimensions Pressure Control DR

Before finishing your design, please request a certified drawing.

Sizes 28...100

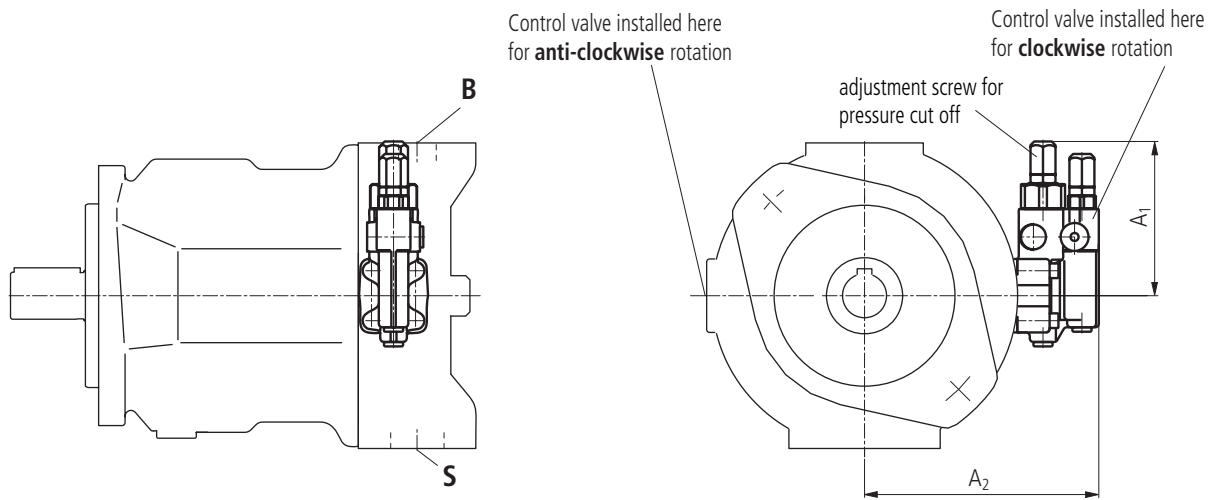

On sizes 28 to 100 the DFR valve used has the flow control spool blocked in the factory and is not tested.

Size 140

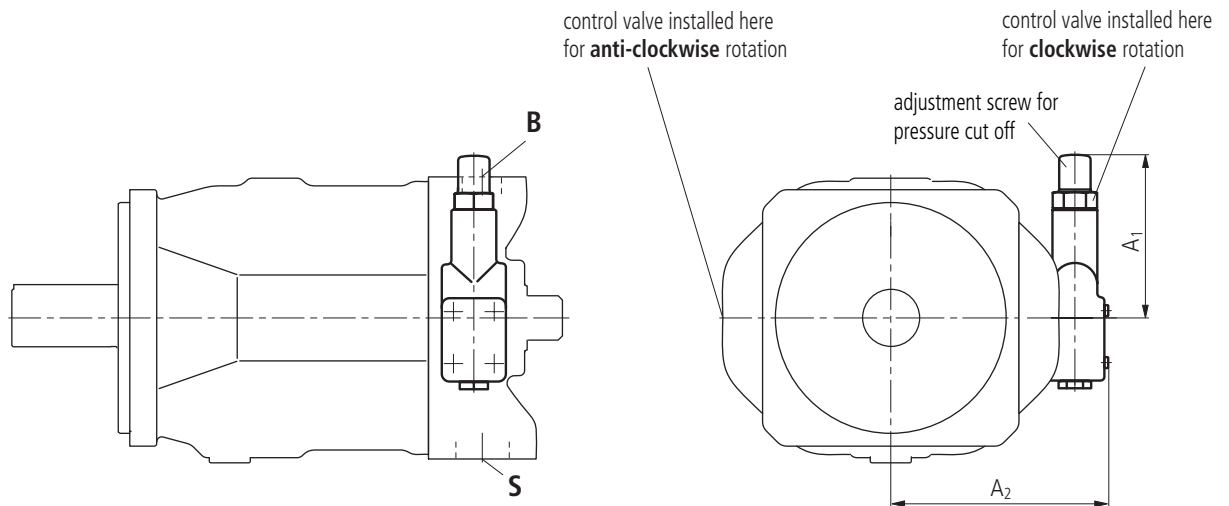

Size	A ₁	A ₂
28	109	136
45	106	146
71	106	160
100	106	165
140	127	169

DRG Pressure Controller, Remote Control

Function and equipment as for DR.

A pressure relief valve can be connected to port X for remote control applications; this is not included in the items supplied with the DRG control.

The standard pressure differential setting at the control valve is 20 bar. A pilot oil flow of approx. 1,5 L/min is then used. If an other setting (range 10-22 bar) is required please indicate in clear text.

We recommend the following as separate pressure relief valves:

DBDH 6 (hydraulic) to RE 25402 or

DBETR -SO 381 with orifice $\varnothing 0,8$ in P (electric) to RE 29166.

The max. pipe length should not exceed 2m.

Static Operating Curve

(at $n_1 = 1500$ rpm; $t_{oil} = 50^\circ C$)

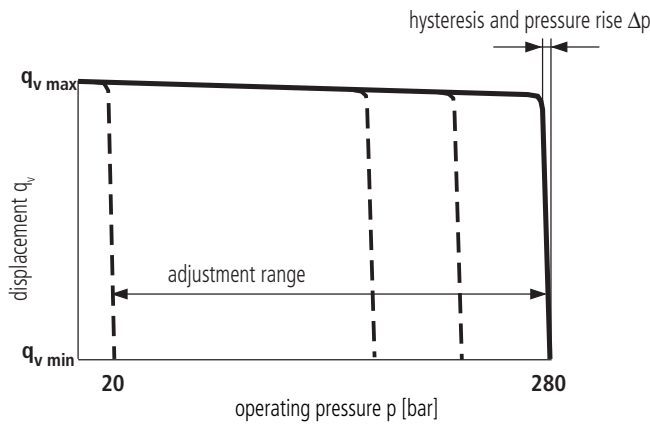

Controller data

Hysteresis Δp _____ max. 3 bar

Max. pressure rise

Size	28	45	71	100	140
Δp bar	4	6	8	10	12

Pilot oil requirement _____ approx. 4,5 L/min

Flow loss at $q_{v\ max}$ see pages 8 and 9.

Sizes 28...100

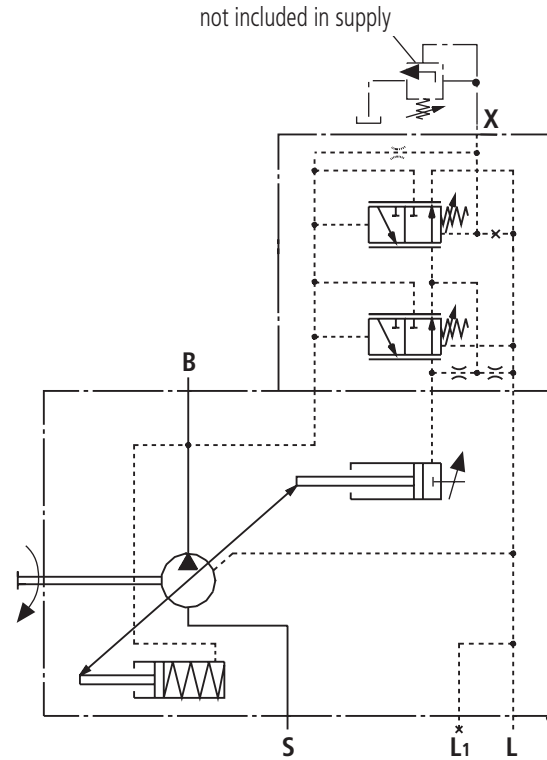

Size 140

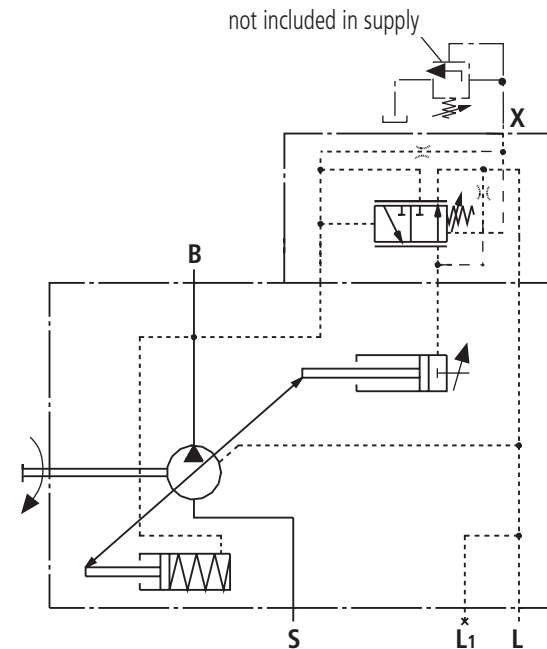

Ports

- B** Pressure port
- S** Suction port
- L, L1** Case drain ports (L1 plugged)
- X** Pilot pressure port

Unit Dimensions Pressure Controller with Remote Control DRG

Before finishing your design, please request a certified drawing.

Size 28...100

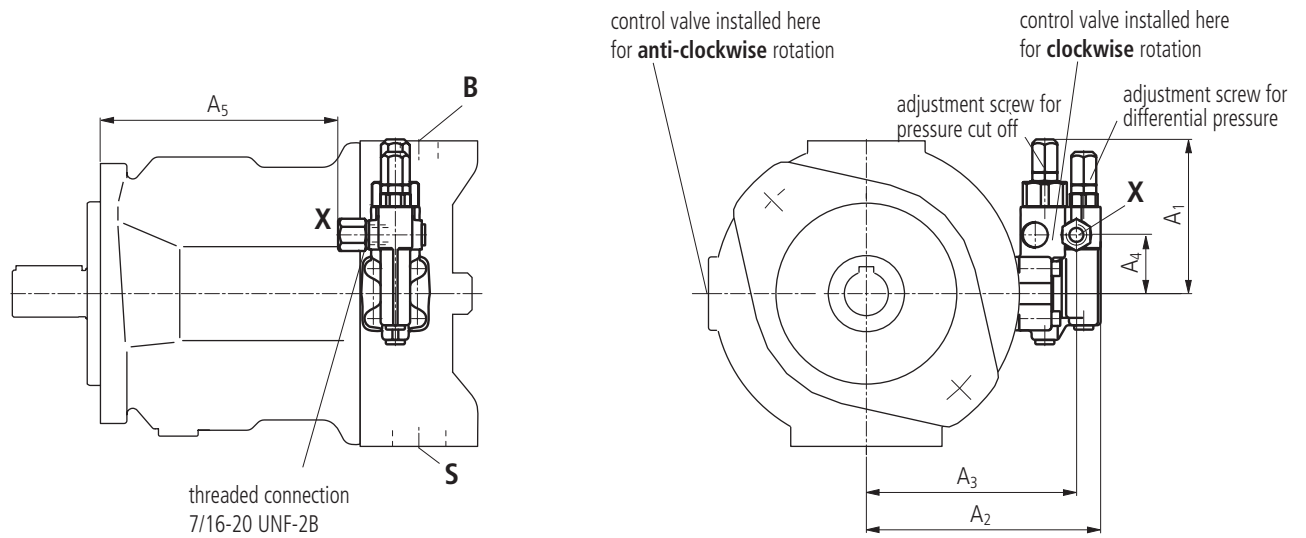

Size 140

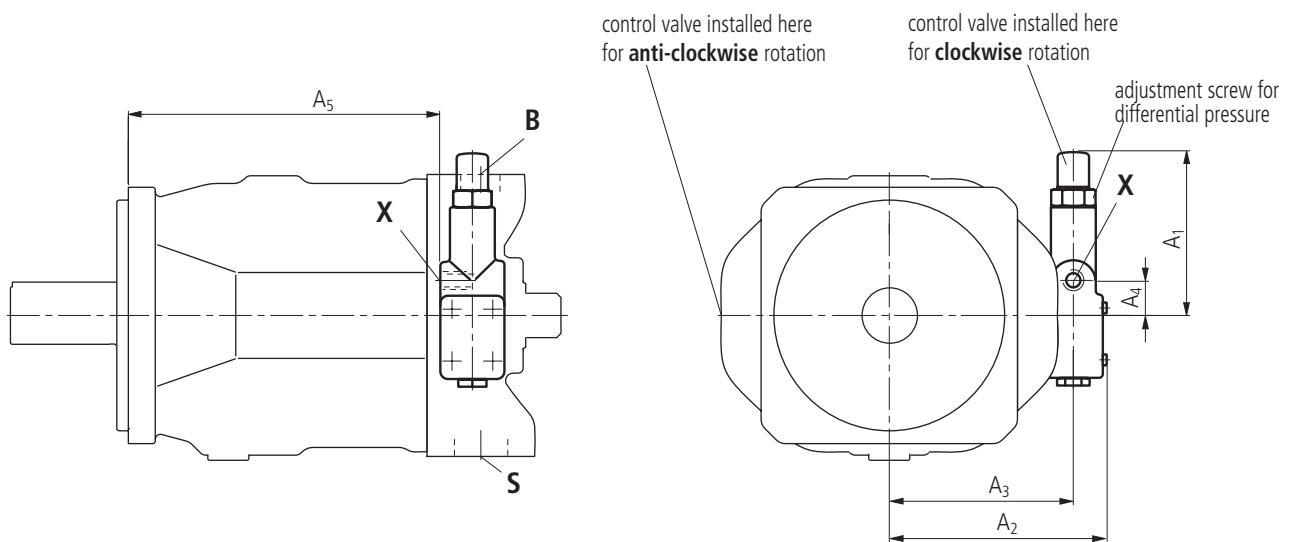

Size	A ₁	A ₂	A ₃	A ₄	A ₅	Port X
28	109	136	119	40	119	M14x1,5; 12 deep
45	106	146	129	40	134	M14x1,5; 12 deep
71	106	160	143	40	162	M14x1,5; 12 deep
100	106	165	148	40	229	M14x1,5; 12 deep
140	127	169	143	27	244	M14x1,5; 12 deep

} with adaptor

without adaptor

DFR/DFR1 Pressure / Flow Control

In addition to the pressure control function, the pump flow may be varied by means of a differential pressure over an orifice or valvespool, installed in the service line. The pump flow is equal to the actual required flow by the actuator.

The DFR1-valve has no connection between X and the tank.

For function of pressure control see pages 16/17.

Static operating curve

(at $n_1 = 1500 \text{ rpm}$; $t_{oil} = 50^\circ \text{ C}$)

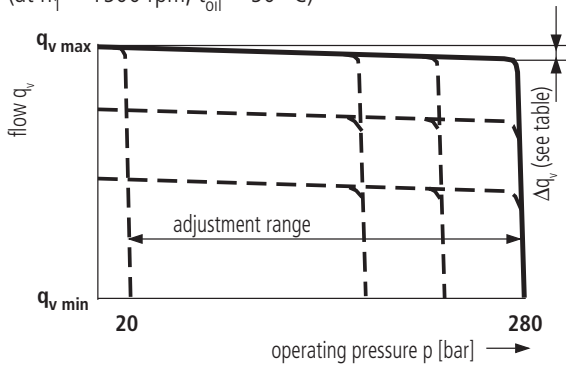

Static operating curve at variable speed

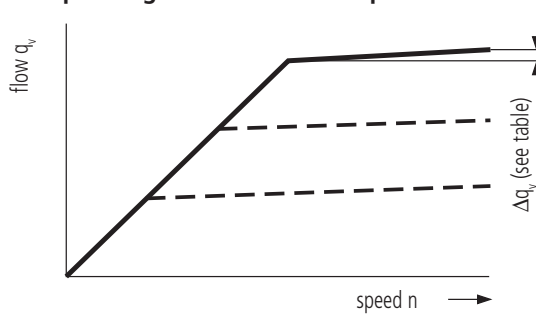

Dynamic flow control operating curve

The operating curves are average values measured under test conditions with the unit mounted inside the tank.

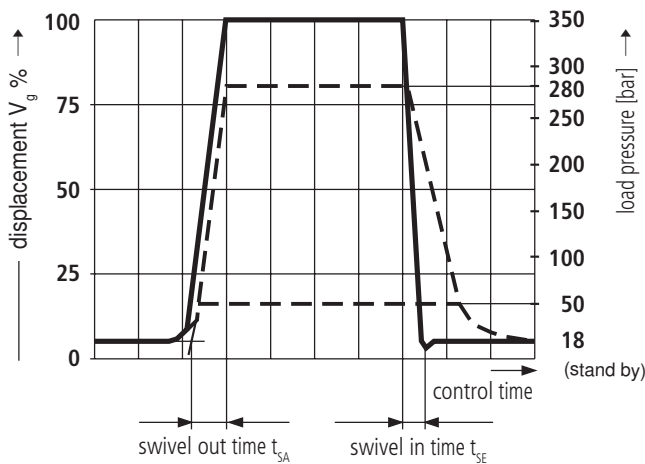

NG	t_{SA} [ms] stand by-280 bar	t_{SE} [ms] 280 bar-stand by	t_{SE} [ms] 50 bar-stand by
28	40	20	40
45	50	25	50
71	60	30	60
100	120	60	120
140	130	60	130

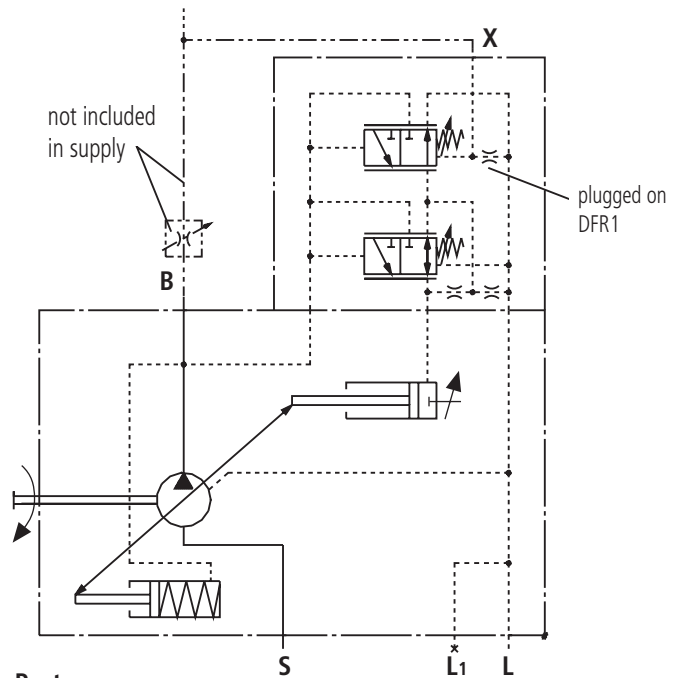

Ports

- B** Pressure port
- S** Suction port
- L, L1** Case drain ports (L1 plugged)
- X** Pilot pressure port

Differential pressure Δp :

Adjustable between 10 and 22 bar (higher values on request).

Standard setting: 14 bar. If a different setting is required please indicate in clear text.

When port X is unloaded to tank a "zerostroke pressure" of $p = 18 \pm 2 \text{ bar}$ ("stand by") results (dependent on Δp).

Controller data

Data pressure controller see page 16.

Max. flow variation (hysteresis and increase) measured at drive speed $n = 1500 \text{ rpm}$

Size	28	45	71	100	140	
Δq_{vmax}	L/min	1,0	1,8	2,8	4,0	6,0

DFR pilot oil consumption _____ max. approx. 3 ... 4,5 L/min

DFR1 pilot oil consumption _____ max. approx. 3 L/min

Flow loss at q_{vmax} see page 8 and 9.

Unit Dimensions DFR; DFR1 Pressure and Flow Control

Before finishing your design, please request a certified drawing.

Sizes 28...100

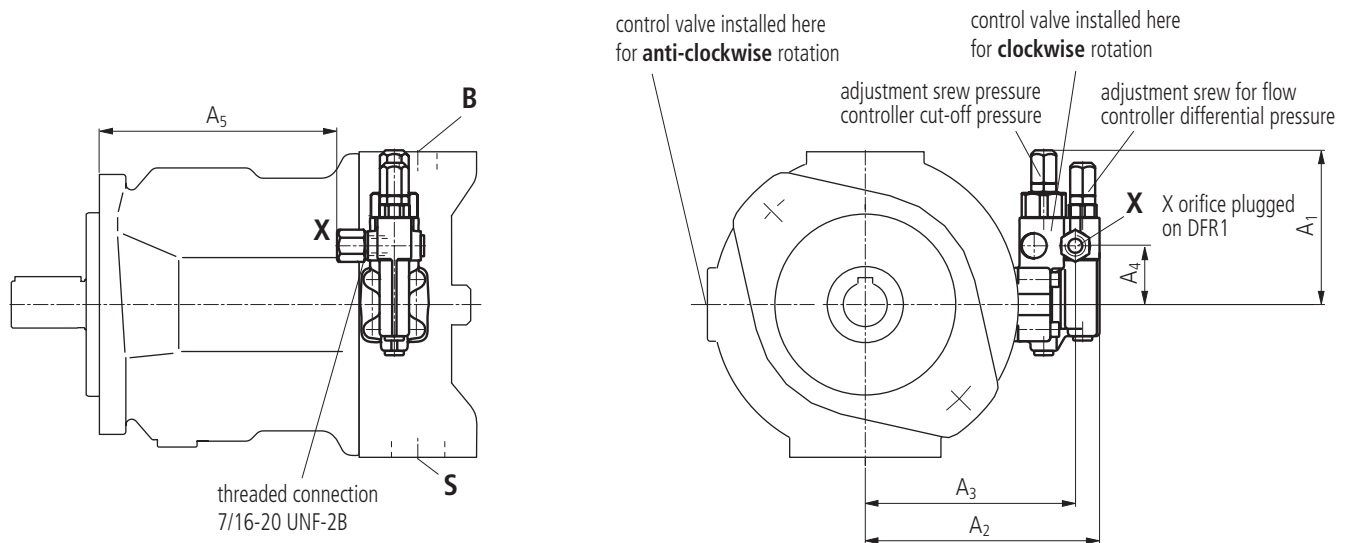

Size 140

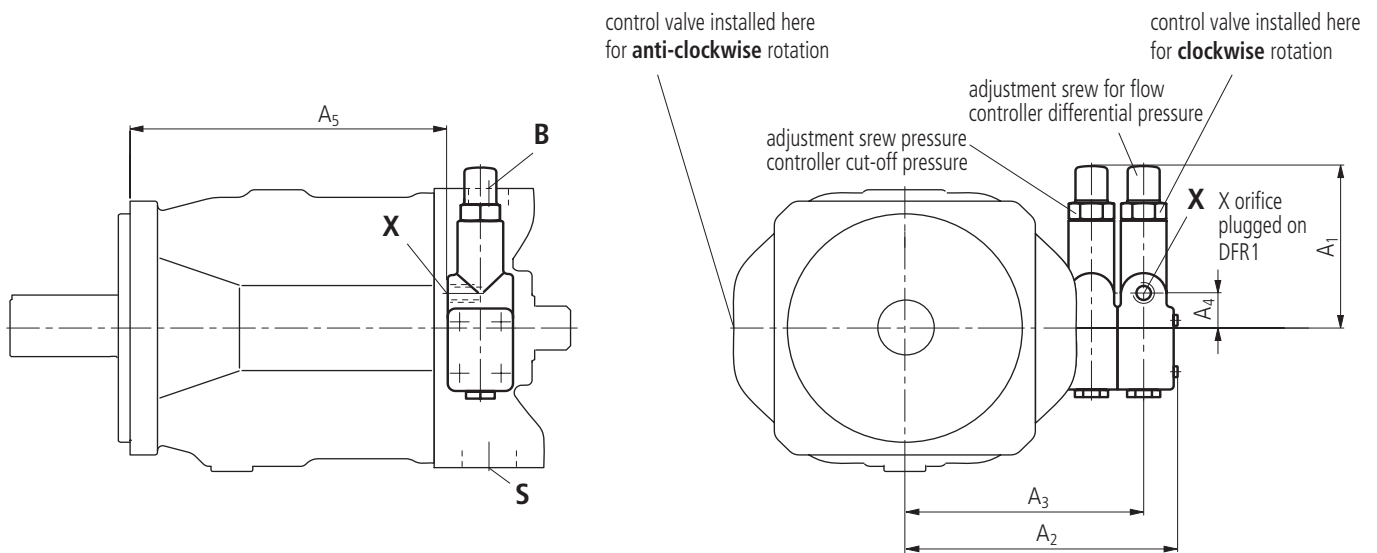

NG	A_1	A_2	A_3	A_4	A_5	port X	
28	109	136	119	40	119	M14x1,5; 12 deep	} with adaptor
45	106	146	129	40	134	M14x1,5; 12 deep	
71	106	160	143	40	162	M14x1,5; 12 deep	
100	106	165	148	40	229	M14x1,5; 12 deep	
140	127	209	183	27	244	M14x1,5; 12 deep	without adaptor

DFLR Pressure / Flow / Power Control

In order to achieve a constant drive torque with a varying operating pressure, the swivel angle and with it the output flow of the axial piston pump is varied so that the product of flow and pressure remains constant.

Constant flow control is possible below the power curve.

Static operating curve

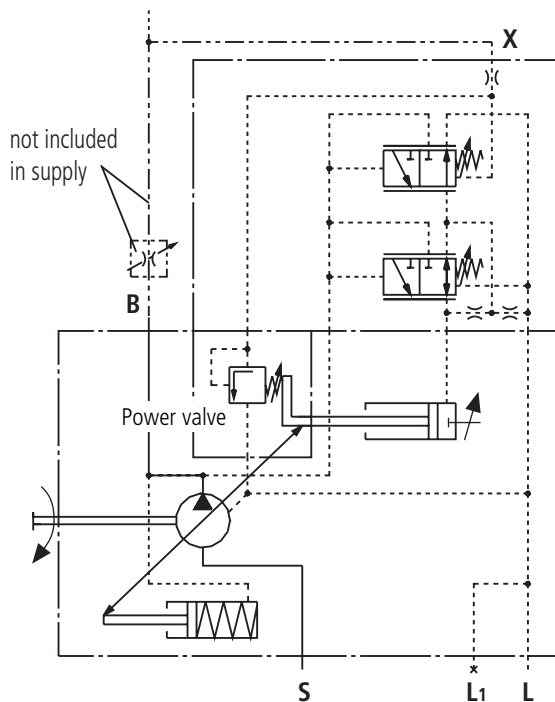
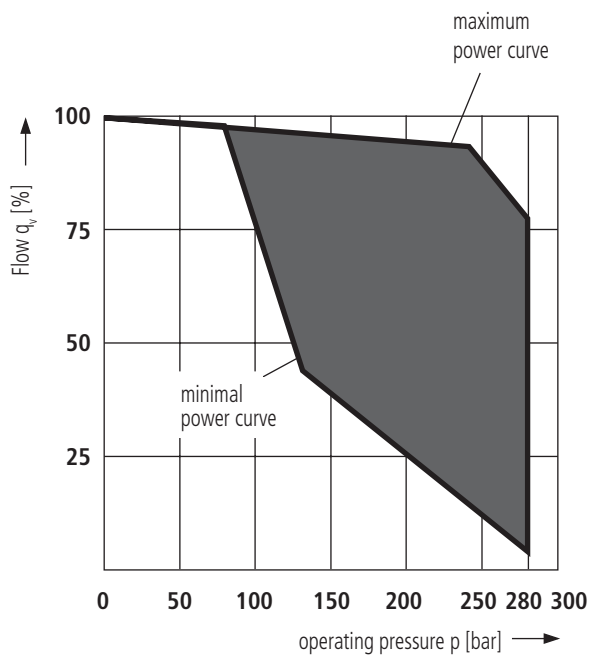

Ports

- B** Pressure port
- S** Suction port
- L, L1** Case drain ports (L1 plugged)
- X** Pilot pressure port

The power curve is set at the factory, please state your requirements in clear text e.g. 20 kW at 1500 rpm.

Controller data

Technical data constant pressure control see page 16.

Technical data flow control see page 20.

Start of control _____ from 80 bar

Pilot oil requirement _____ max. approx. 5,5 L/min

Flow loss at q_{vmax} see pages 8 and 9.

Unit Dimensions Pressure / Flow / Power Control DFLR

Before finishing your design, please request a certified drawing.

Sizes 28...100

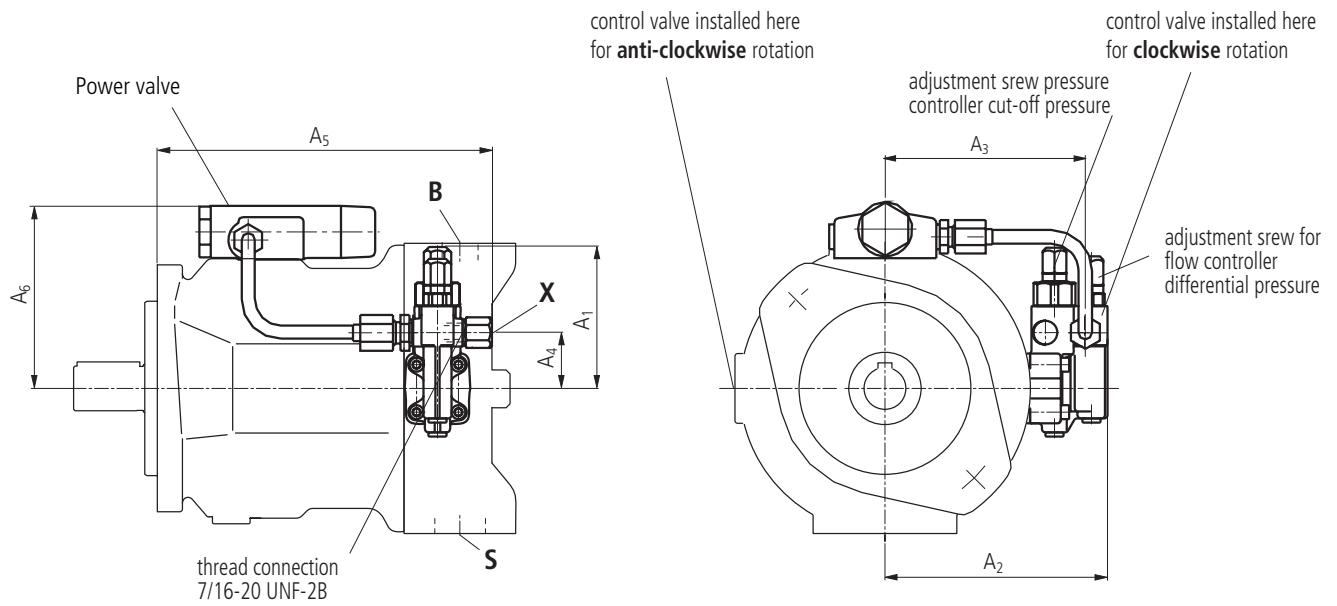

Size 140

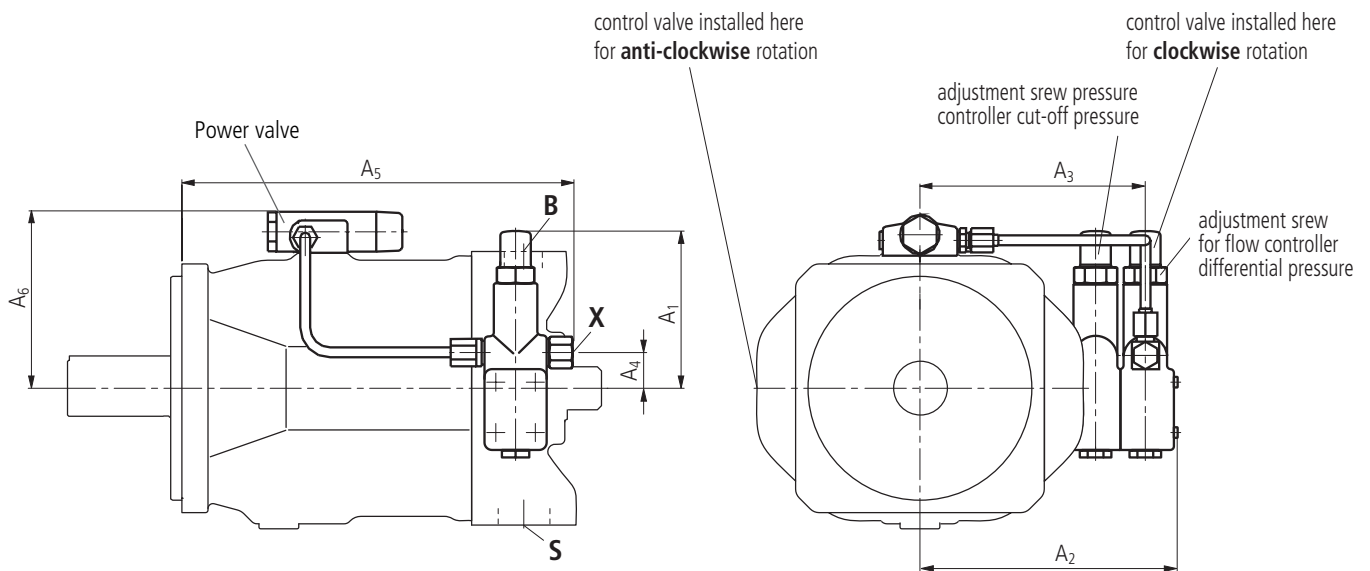

NG	A_1	A_2	A_3	A_4	A_5	A_6	Port X
28	109	136	119	40	197	107	M14x1,5; 12 deep
45	106	146	129	40	212	112	M14x1,5; 12 deep
71	106	160	143	40	240	124	M14x1,5; 12 deep
100	106	165	148	40	307	129	M14x1,5; 12 deep
140	127	209	183	27	314	140	M14x1,5; 12 deep

FHD Pilot Pressure Dependent Flow Control with Pressure Cut-off

The swivel angle of the pump and therefore its displacement is dependent on the pilot pressure p_{StX} present in port X.

A constant pressure of $p_y = 35$ bar must be applied to port Y. The integral pressure control is steplessly adjustable.

(Please state set value required in clear text).

Controller data

Hysteresis $\pm 2\%$ of $V_{g\ max}$

External pilot oil consumption in Y _____ max. approx. 3 ... 4,5 L/min

Pressure rise Δp _____ max. 4 bar

Flow loss at $q_{v\ max}$ see pages 8 and 9.

Ports

- B** Pressure port
- S** Suction port
- L, L1** Case drain port (L1 plugged)
- X, Y** Pilot pressure ports
- MSt** Test port

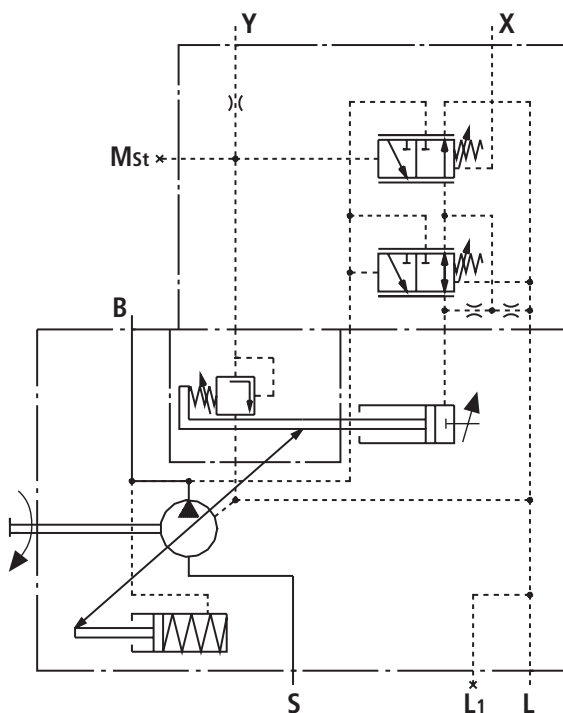

Static curve

(at $n_1 = 1500$ rpm; $t_{oil} = 50^\circ$ C)

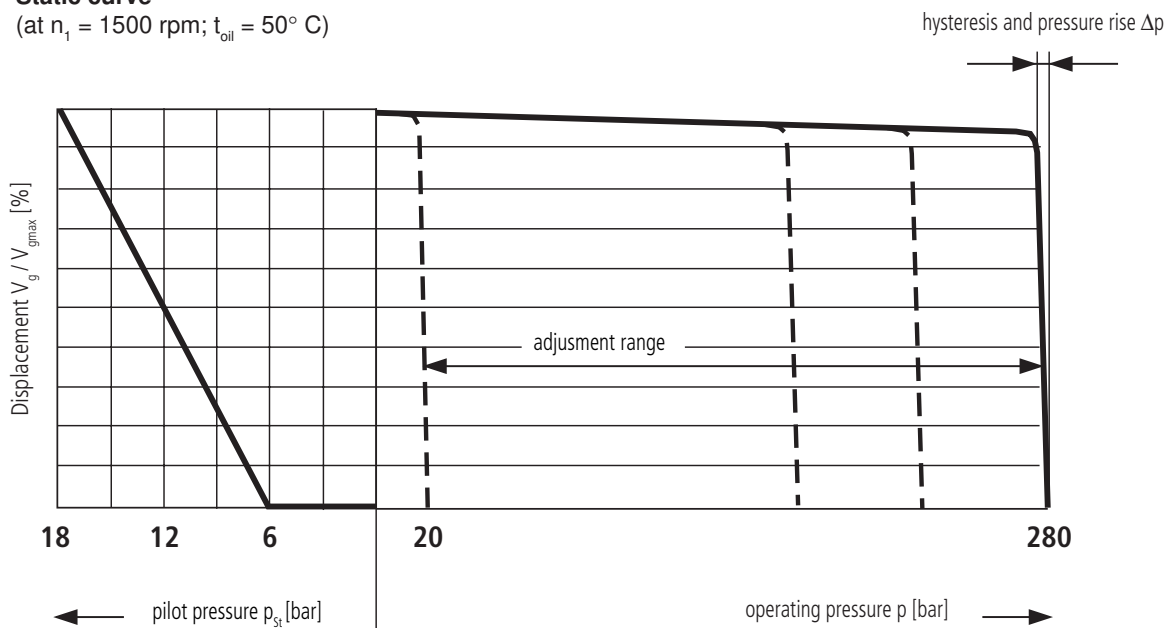

Unit Dimensions FHD Pilot Pressure Dependent Flow Control with Pressure Cut-off

Before finishing your design, please request a certified drawing.

Sizes 28...100

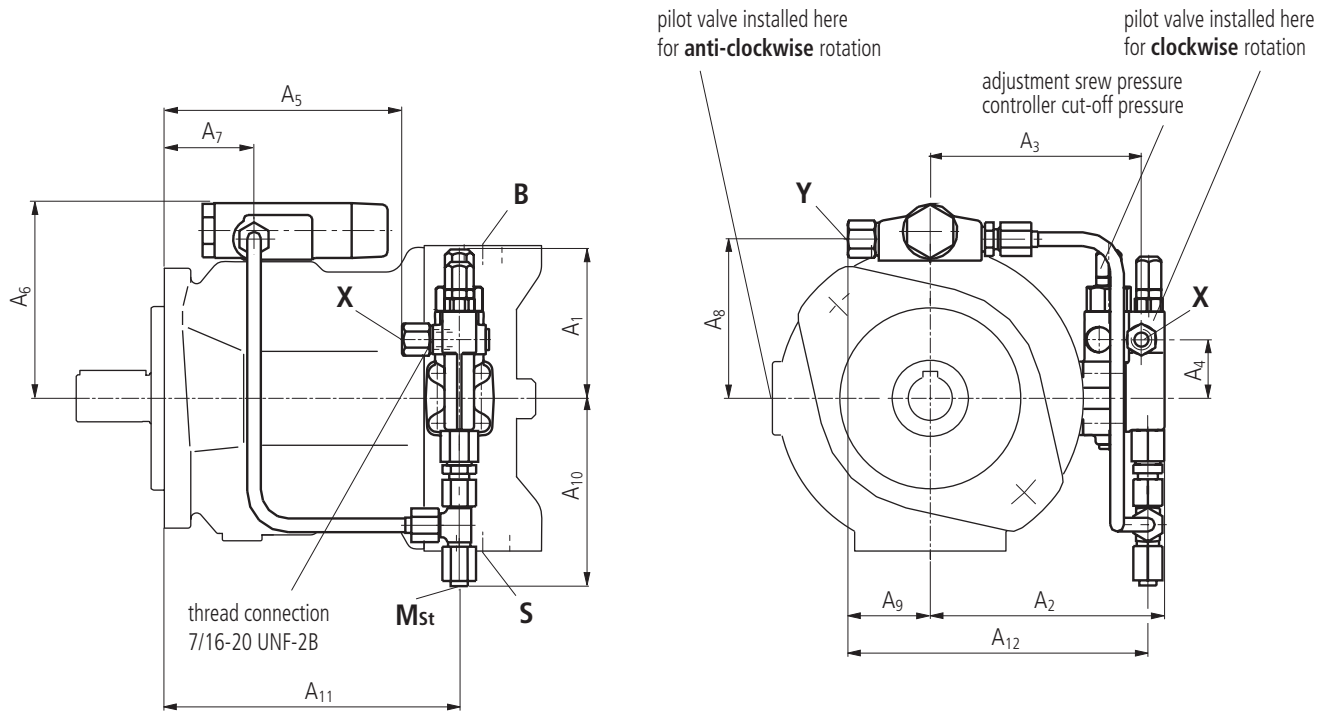

Size 140

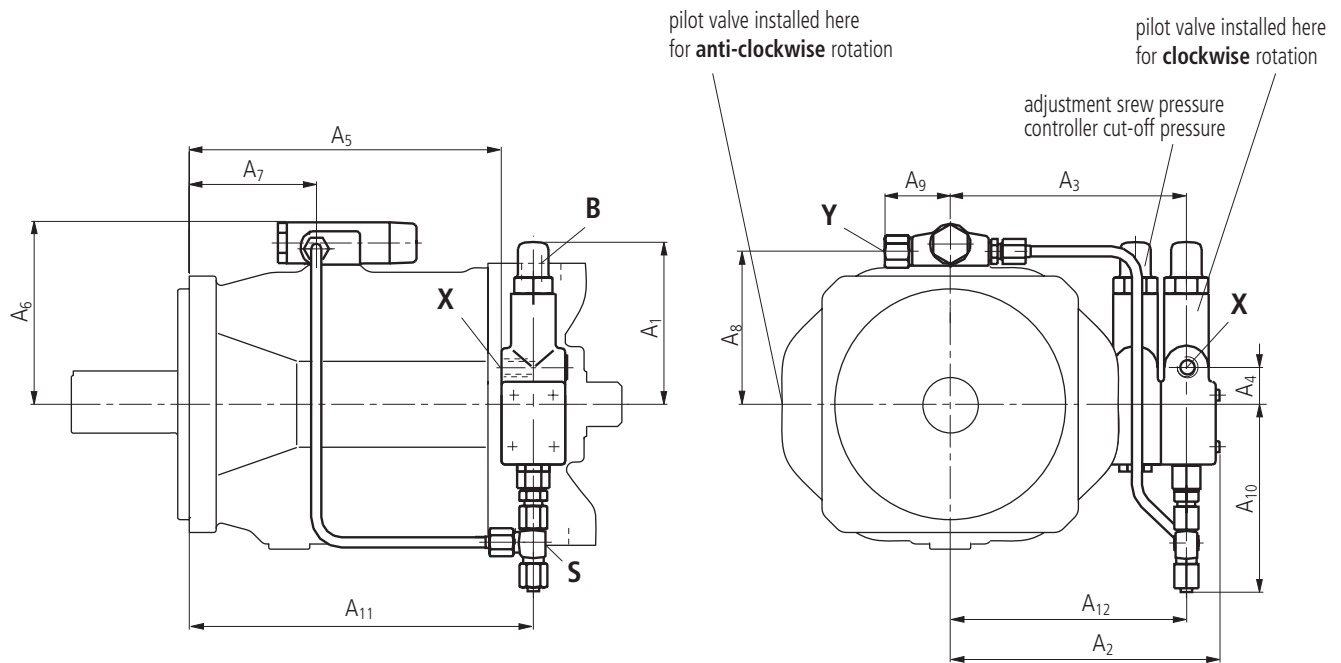

NG	A ₁	A ₂	A ₃	A ₄	A ₅	A ₆	A ₇	A ₈	A ₉	A ₁₀	A ₁₁	A ₁₂	Port X	Port Y	M _{St}
28	109	136	119	40	119	107	48	86	51	113	158	124	M14x1,5	M14x1,5	Pipe dia ø8x1,5 DIN 2391
45	106	146	129	40	134	112	54	91,5	51	113	173	134	M14x1,5	M14x1,5	Pipe dia ø8x1,5 DIN 2391
71	106	160	143	40	162	124	69	103,5	51	113	201	148	M14x1,5	M14x1,5	Pipe dia ø8x1,5 DIN 2391
100	106	165	148	40	229	129	111	108,5	51	113	268	153	M14x1,5	M14x1,5	Pipe dia ø8x1,5 DIN 2391
140	127	209	183	27	244	140	99	119	51	150	268	183	M14x1,5	M14x1,5	Pipe dia ø8x1,5 DIN 2391

Through drive

The A10VSO pump can be supplied with through drive in accordance with the type code on page 3.

The through drive version is designated by the code numbers (KB2–K57).

If no other pumps are fitted by the manufacturer, the simple type designation is sufficient.

In this case, the delivery package comprises:

Hub, fixing screws, seal and, if necessary, an adaptor flange.

Combination pump

By building on further pumps it is possible to obtain independent circuits:

1. If the combination pump consists of **2 A10VSO** and if these are to be **supplied assembled** then the two order codes should be linked by means of a „+“ sign.

Ordering example:

A10VSO 71 DR/31 L–PPA12KB3 +
A10VSO 28 DR/31 L–PSA12N00

2. If a **gear or radial piston pump** is to be built on at the factory, please consult us.

Permissible moment of inertia

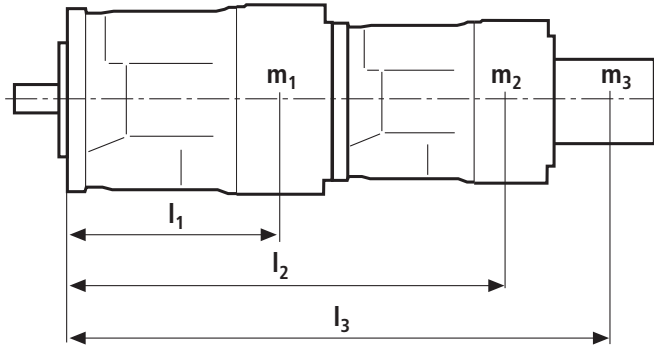

m_1, m_2, m_3 [kg] Pump mass

l_1, l_2, l_3 [mm] Distance to center of gravity

$$T_m = (m_1 \cdot l_1 + m_2 \cdot l_2 + m_3 \cdot l_3) \cdot \frac{1}{102} \text{ [Nm]}$$

Size		28	45	71	100	140
Permissible moment of inertia T_m	Nm	880	1370	2160	3000	4500
Permissible moment of inertia T_m	Nm	88	137	216	300	450
at dynamic mass acceleration $10g \cong 98.1 \text{ m/sec}^2$						
Mass	m_1 kg	15	21	33	45	60
To center of gravity	l_1 mm	110	130	150	160	160

Maximum permissible input and through drive torque

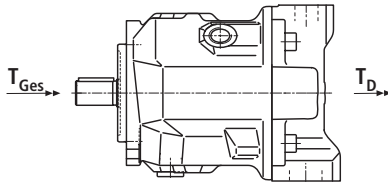

The split in torque between pump 1 and 2 is optional. The max. permissible input torque T_{tot} as well as the max. permissible through-drive torque T_D may not be exceeded.

Size		28	45	71	100	140
Max. permissible input torque at pump 1 with shaft "P"						
	T_{tot} Nm	137	200	439	857	1206
Max. permissible through-drive torque						
	T_D Nm	137	200	439	778	1206
	$T_{D \text{ keyed shaft}}$ Nm	112	179	283	398	557

Size		28	45	71	100	140
Max. permissible input torque at pump 1 with shaft "S"						
	T_{tot} Nm	198	319	626	1104	1620
Max. permissible through-drive torque						
	T_D Nm	160	319	492	778	1266
	$T_{D \text{ keyed shaft}}$ Nm	112	179	283	398	557

Size		28	45	71	100	140
Max. permissible input torque at pump 1 with shaft "R"						
	T_{tot} Nm	225	400	644	–	–
Max. permissible through-drive torque						
	T_D Nm	176	365	548	–	–
	$T_{D \text{ keyed shaft}}$ Nm	112	179	283	–	–

T_{tot} = Max. permissible input torque at pump 1

T_D = Max. permissible through-drive torque at through-drive to splined shaft

$T_{D \text{ keyed shaft}}$ = Max. permissible through-drive torque at through-drive to keyed shaft

Unit Dimensions: Combination Pumps

Before finishing your design, please request a certified drawing.

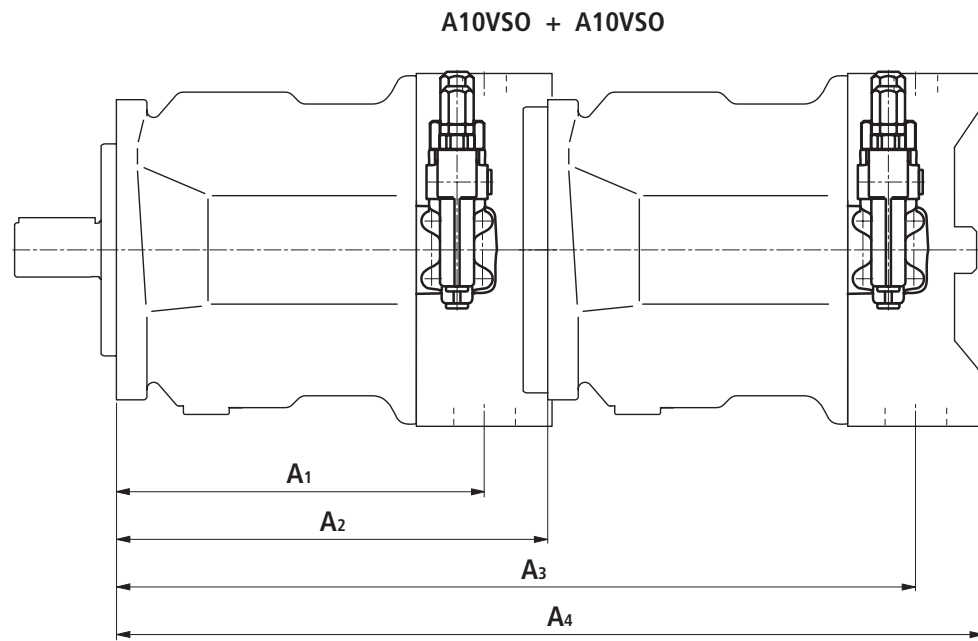

main p. built-on p.	A10VSO 28				A10VSO 45				A10VSO 71				A10VSO 100				A10VSO 140			
	A ₁	A ₂	A ₃	A ₄	A ₁	A ₂	A ₃	A ₄	A ₁	A ₂	A ₃	A ₄	A ₁	A ₂	A ₃	A ₄	A ₁	A ₂	A ₃	A ₄
A10VSO 18	164	204	349	399	184	229	374	424	217	267	412	462	275	338	483	533	275	350	495	545
A10VSO 28	164	204	368,5	410	184	229	393,5	435	217	267	431,5	473	275	338	502,5	544	275	350	514	556
A10VSO 45	–	–	–	–	184	229	413	453	217	267	451	491	275	338	522	562	275	350	534	574
A10VSO 71	–	–	–	–	–	–	–	–	217	267	484	524	275	338	555	595	275	350	567	609
A10VSO 100*	–	–	–	–	–	–	–	–	–	–	–	–	275	338	613	664	275	350	625	679
A10VSO 140*	–	–	–	–	–	–	–	–	–	–	–	–	–	–	–	–	275	350	625	688

* Values with through drive KB6 or KB7 (splined shaft)

Unit Dimensions Through Drives KB2 and K51

Before finishing your design, please request a certified drawing.

Flange ISO 80, 2-hole for built-on A10VSO 10 (splined shaft S, mounting flange A, see RD 92713) or A10VSO 18 (splined shaft S or R, mounting flange A, see RD 92712)

Order code **KB2**

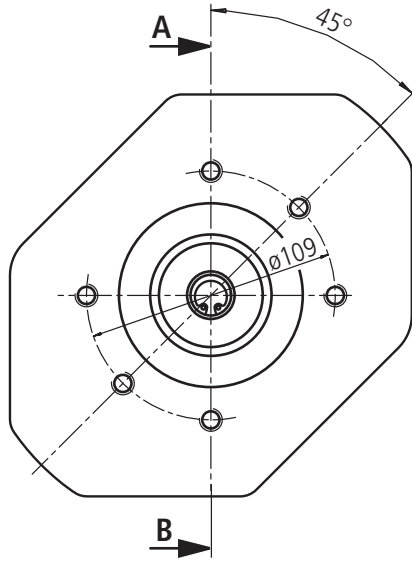

section A - B

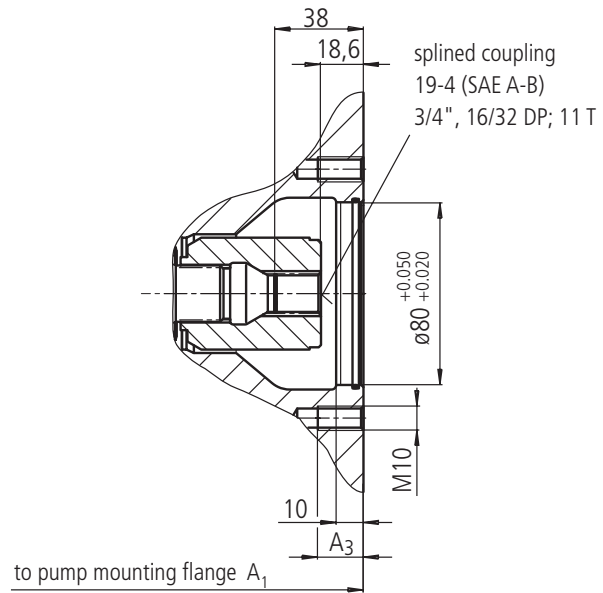

Size main pump	A ₁	A ₃
18 (see RD 92712)	182	14,5
28	204	16
45	229	16
71	267	20

For operation with HF-fluids please consider RE-data sheet of built-on pump.

Flange ISO 80, 2-hole for built-on A10VSO 10 (shaft P, flange A, see RD 92713) or A10VSO 18 (shaft P, flange A, see RD 92712)

Order code **K51***

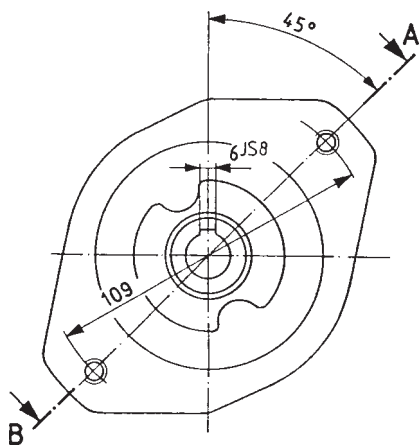

section A - B

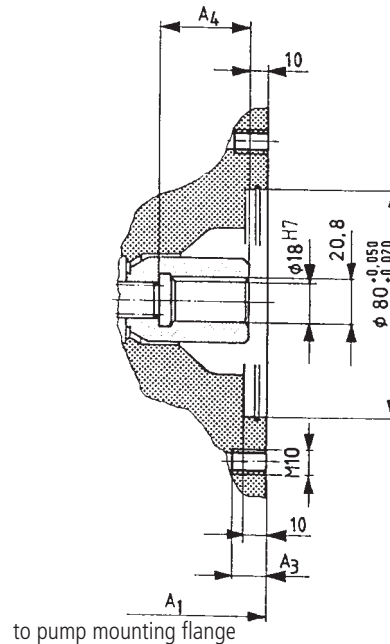

Size main pump	A ₁	A ₃	A ₄
18 (see RD 92712)	182	14,5	33
28	204	16	37
45	229	16	43
71	267	20	51
100	338	20	55
140	350	20	67

For operation with HF-fluids please consider RE-data sheet of built-on pump.

*not for new applications, only permitted with reduced through drive torques, see page 26.

Unit Dimensions Through Drives KB3 and K25

Before finishing your design, please request a certified drawing.

Flange ISO 100, 2-hole for built-on A10VSO 28 (splined shaft S or R);

Order code **KB3**

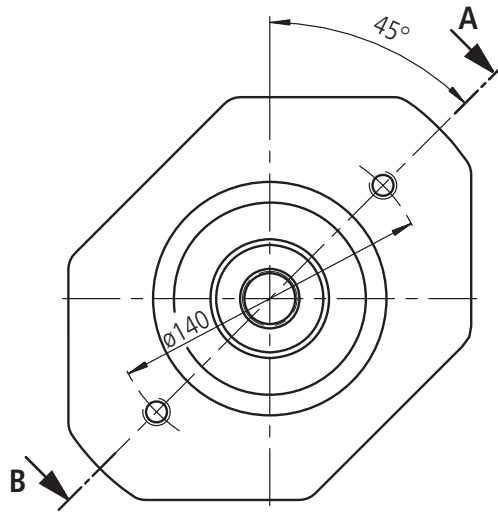

section A - B

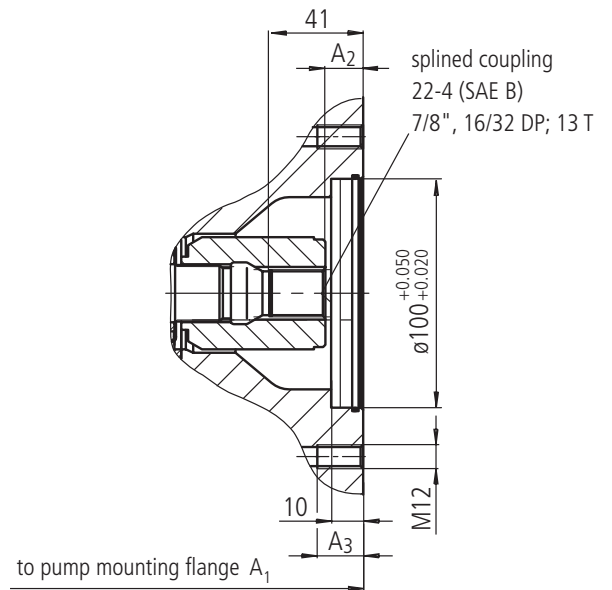

Size main pump	A ₁	A ₂	A ₃
28	204	19,2	14
71	267	16,5	18
100	338	17,6	18
140	350	18,2	24

Flange ISO 100, 2-hole for built-on A10VSO 28 (keyed shaft P)

Order code **K25***

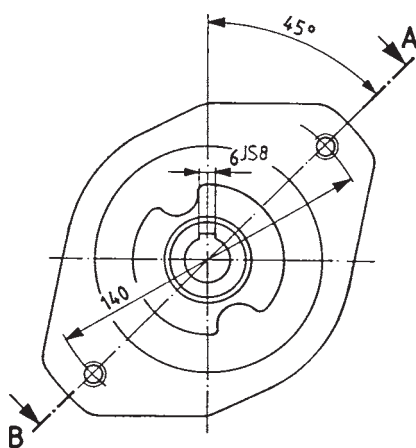

section A - B

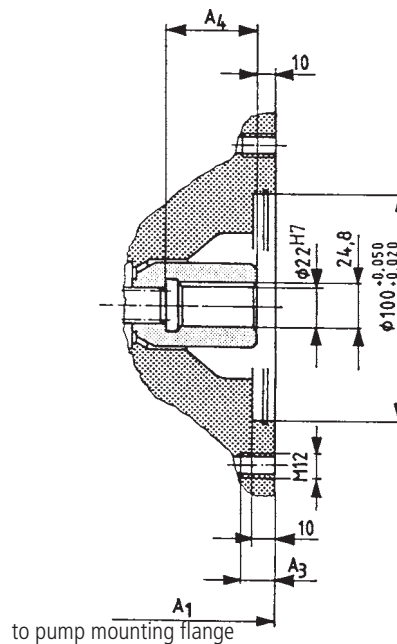

Size main pump	A ₁	A ₃	A ₄
28	204	14	37
45	229	14	43
71	267	23	51
100	338	20	55
140	350	24	62

*not for new applications, only permitted with reduced through drive torques, see page 26.

Unit Dimensions Through Drives KB4 and K26

Before finishing your design, please request a certified drawing.

Flange ISO 100, 2-hole for built-on A10VSO 45 (splined S or R);
order code **KB4**

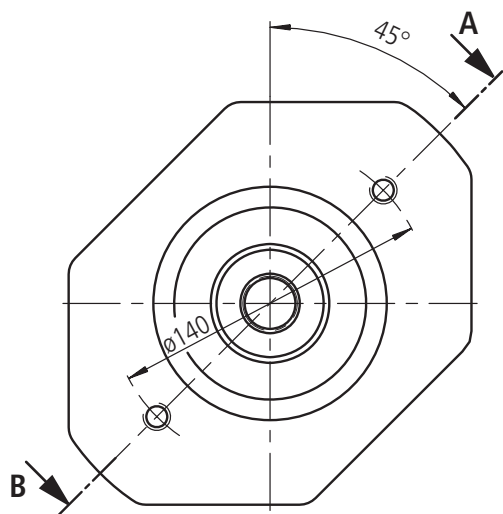

Size main pump	A ₁	A ₂	A ₃
45	229	17,2	14
71	267	17,2	18
100	338	18,2	20
140	350	18,2	24

section A - B

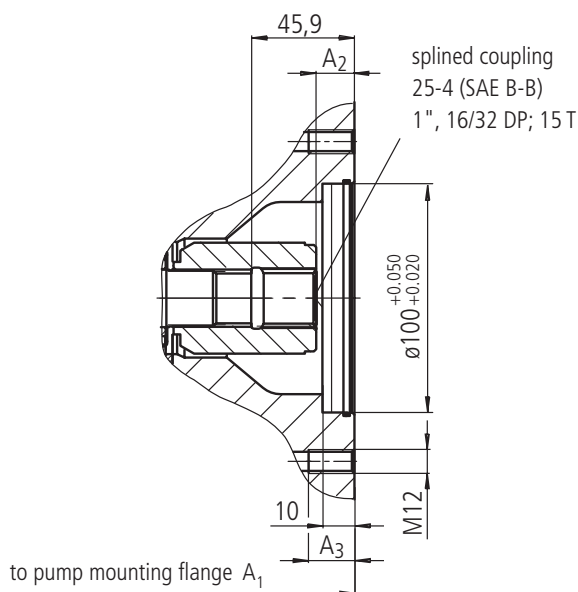

Flange ISO 100, 2-hole for built-on A10VSO 45 (keyed shaft P)
order code **K26***

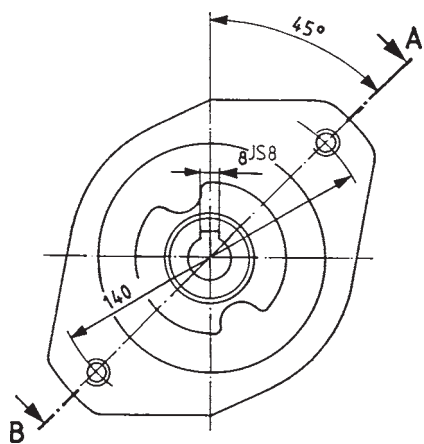

Size main pump	A ₁	A ₃	A ₄
45	229	14	43
71	267	23	51
100	338	20	56
140	350	24	67

section A - B

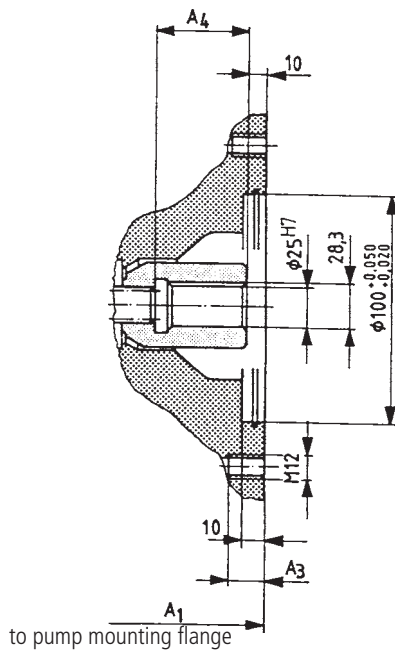

*not for new applications, only permitted with reduced through drive torques, see page 26.

Unit Dimensions Through Drives KB5 and K27

Before finishing your design, please request a certified drawing.

Flange ISO 125, 2-hole for built-on A10VSO 71 (splined shaft S or R);
Order code **KB5**

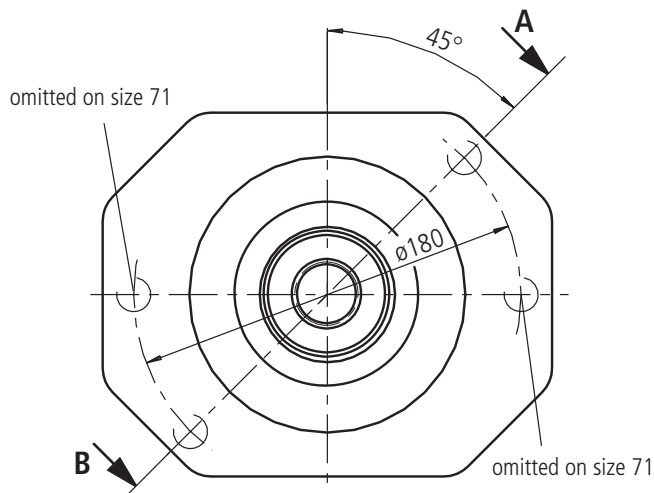

section A - B

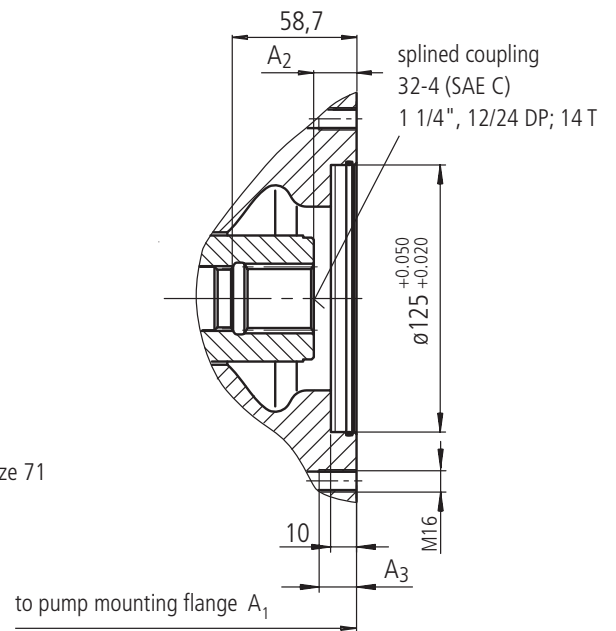

Size main pump	A ₁	A ₂	A ₃
71	267	20	18,5
100	338	20	25
140	350	21	32

Flange ISO 100, 2-hole for built-on A10VSO 71 (keyed shaft P)
order code **K27***

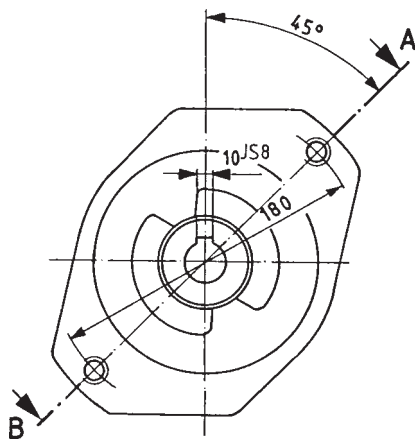

section A - B

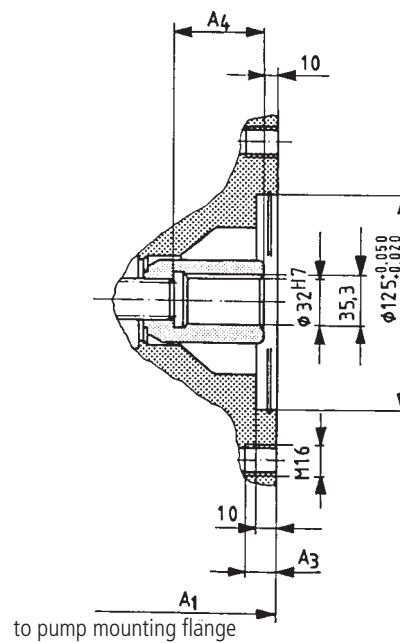

Size main pump	A ₁	A ₃	A ₄
71	267	18	51
100	338	20	54
140	350	24	63

*not for new applications, only permitted with reduced through drive torques, see page 26.

Unit Dimensions Through Drives KB6 and K37

Before finishing your design, please request a certified drawing.

Flange ISO 125, 2-hole for built-on A10VSO 100 (splined shaft S);
Order code **KB6**

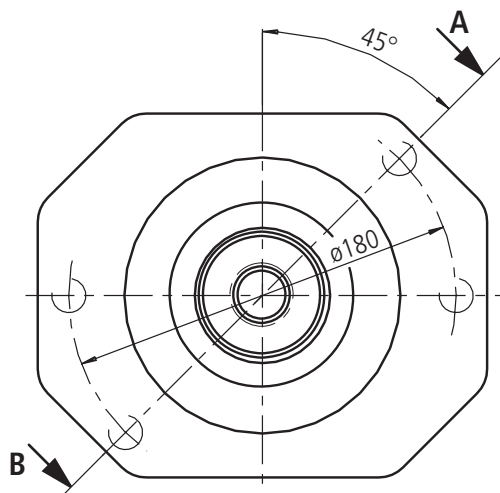

section A - B

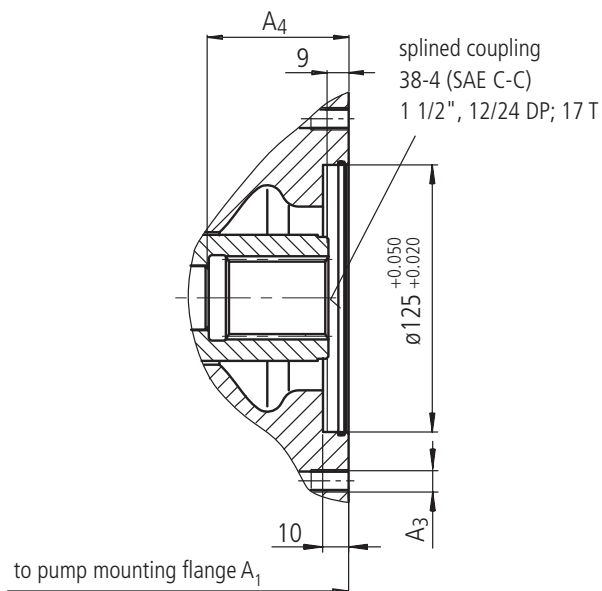

Size main pump	A ₁	A ₃	A ₄
100	338	M16; 25 deep	65
140	350	M16; 32 deep	77,3

Flange ISO 125, 2-hole for built-on A10VSO 100 (keyed shaft P)
Order code **K37***

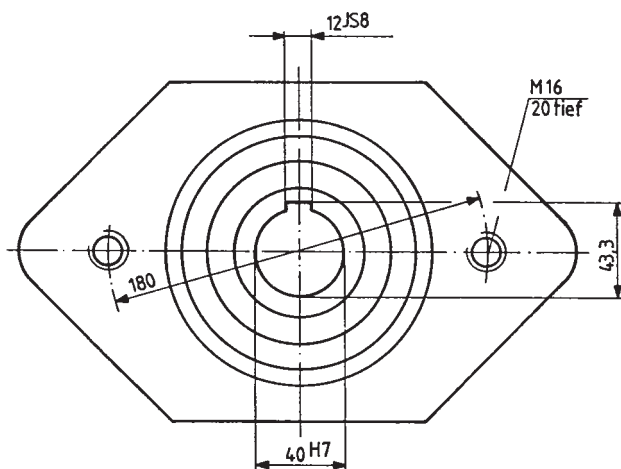

section A - B

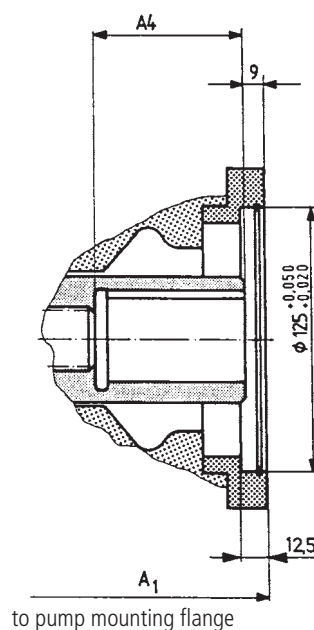

Size main pump	A ₁	A ₄
100	356	71
140	368	80

*not for new applications, only permitted with reduced through drive torques, see page 26.

Unit Dimensions Through Drives KB7 and K59

Before finishing your design, please request a certified drawing.

Flange ISO 180, 4-hole for built-on A10VSO 140 (splined shaft S);

Order code **KB7**

main pump NG 140

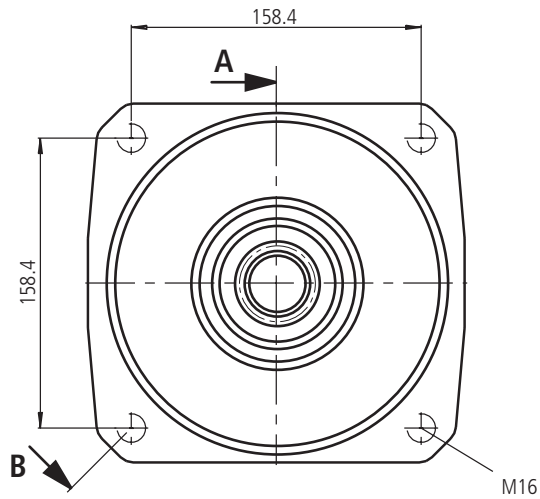

section A - B

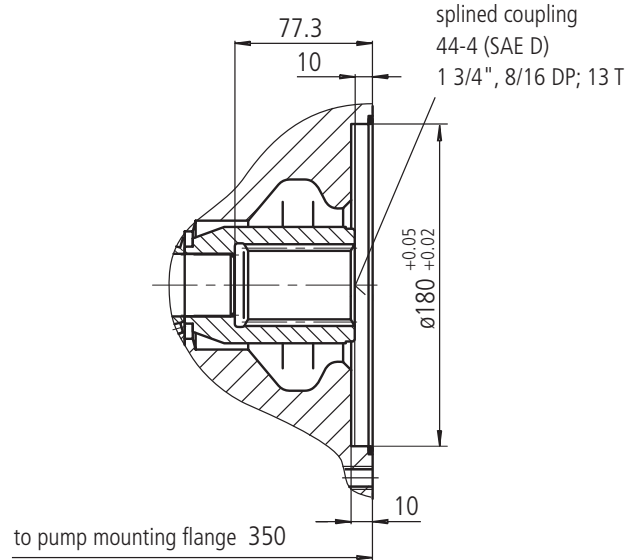

Flange ISO 180, 4-hole for built-on A10VSO 140 (keyed shaft P)

order code **K59***

main pump NG 140

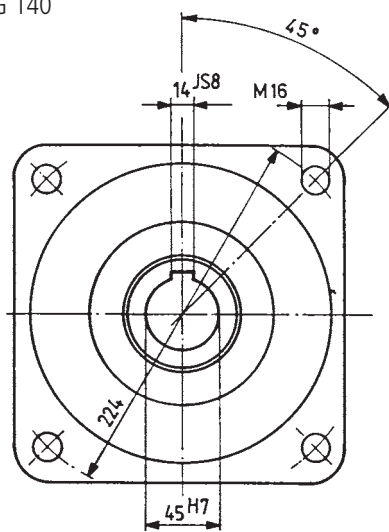

section A - B

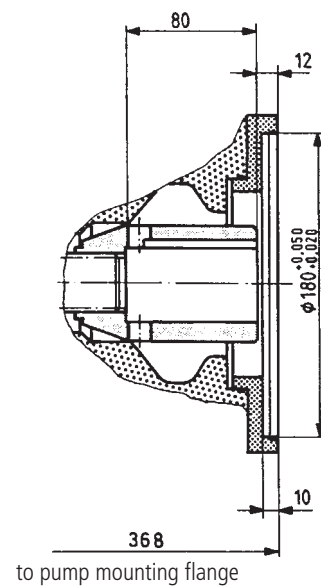

*not for new applications, only permitted with reduced through drive torques, see page 26.

Unit Dimensions Through Drives K01 and K52

Before finishing your design, please request a certified drawing.

Flange SAE 82-2 (SAE A, 2-hole) for built-on external gear pump 1 PF2G2 (see RD 10030) or internal gear pump PGF2 (shaft J, flange U2, see RD 10213)

Order code **K01**

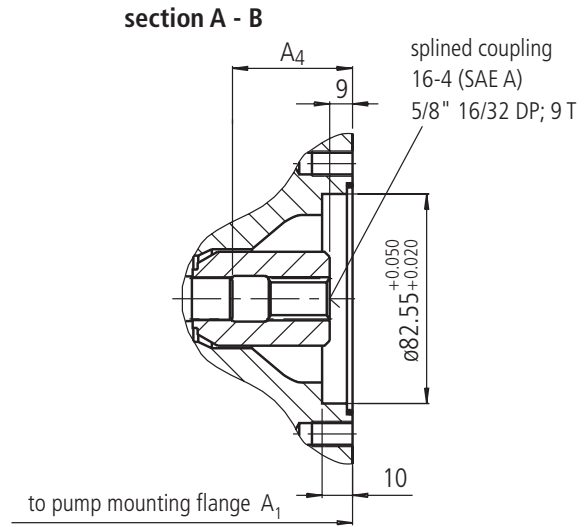
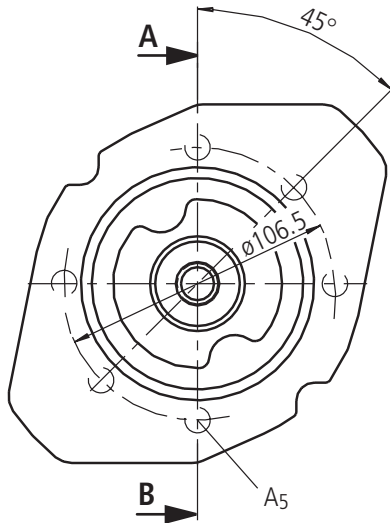

Size main pump	A ₁	A ₄	A ₅
28	204	47	M10; 16 deep
45	229	53	M10; 16 deep
71	267	61	M10; 20 deep
100	338	65	M10; 20 deep
140	350	77	M10; 20 deep

For operation with HF-fluids please consider RE-data sheet of built-on pump.

Flange SAE 82-2 (SAE A, 2-hole) for built-on A10VSO 10 (shaft S, flange C, see RD 92713) or A10VSO 18 (shaft S, flange C, see RD 92712)

Order code **K52**

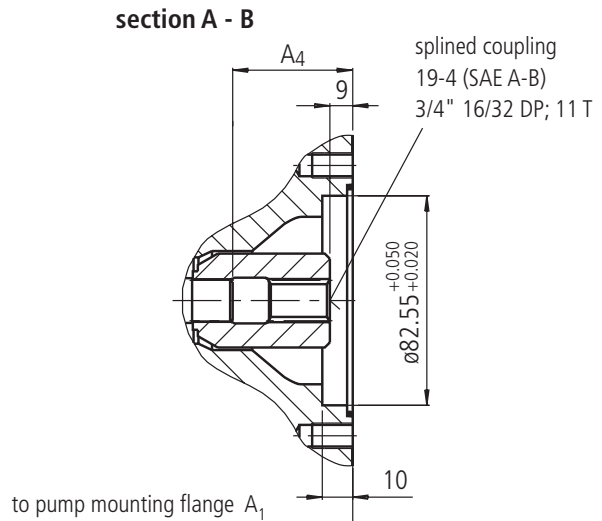
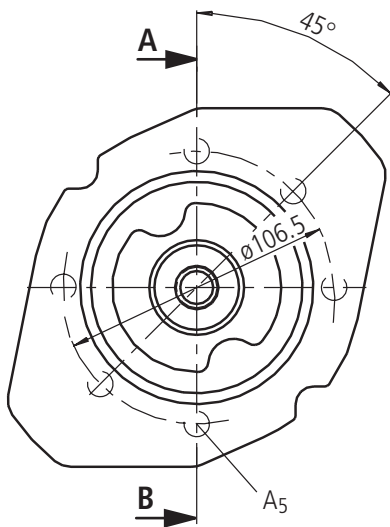

Size main pump	A ₁	A ₄	A ₅
28	206	47,3	M10; 16 deep
45	229	53,4	M10; 16 deep
71	267	61,3	M10; 20 deep
100	338	65	M10; 20 deep
140	350	77	M10; 20 deep

For operation with HF-fluids please consider RE-data sheet of built-on pump.

Unit Dimensions Through Drives K02 and K68

Before finishing your design, please request a certified drawing.

Flange SAE 101-2 (SAE B, 2-hole) for built-on external gear pump 1PF2G3 (see RD 10039)

Order code **K02**

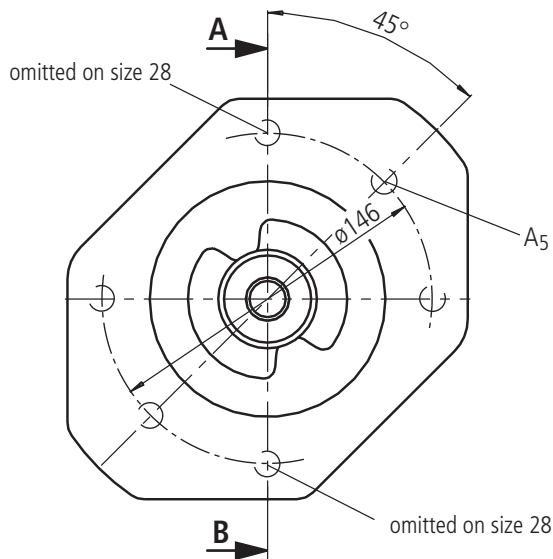

section A - B

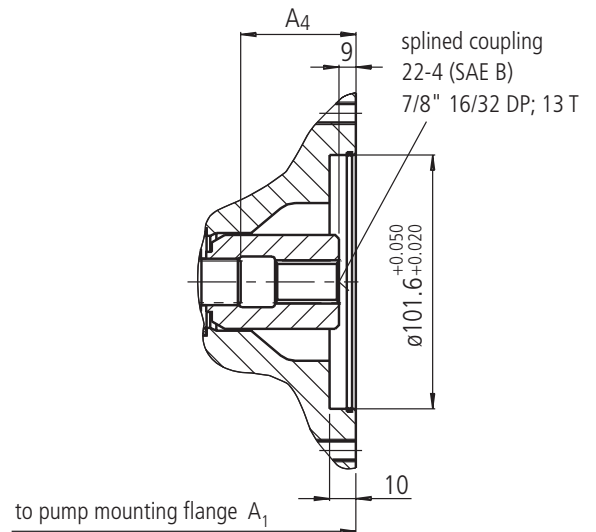

Size main pump	A_1	A_4	A_5
28	204	47	M12; 15 deep
45	229	53	M12; 18 deep
71	267	61	M12; 20 deep
100	338	65	M12; 20 deep
140	350	77	M12; 20 deep

For operation with HF-fluids please consider RE-data sheet of built-on pump.

Flange SAE 101-2 (SAE B, 2-hole) for built-on A10VO 28 (shaft S, see RD 92701) or internal gear pump PGF3 (shaft J, flange U2, see RD 10213)

Order code **K68**

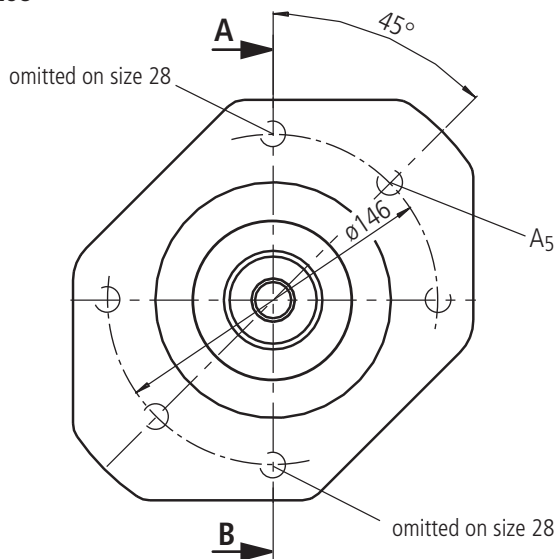

section A - B

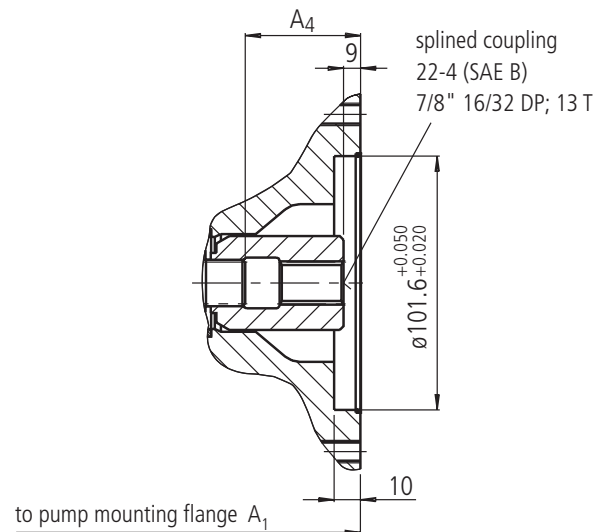

Size main pump	A_1	A_4	A_5
28	204	47	M12; 15 deep
45	229	53	M12; 18 deep
71	267	61	M12; 20 deep
100	338	65	M12; 20 deep
140	350	80,8	M12; 20 deep

For operation with HF-fluids please consider RE-data sheet of built-on pump.

Unit Dimensions Through Drives K04 and K07

Before finishing your design, please request a certified drawing.

Flange SAE 101-2 (SAE B, 2-hole) for built-on A10VO 45 (shaft S, see RD 92701) or internal gear pump PGH4 (shaft R, flange U2, see RD 10223)

Order code **K04**

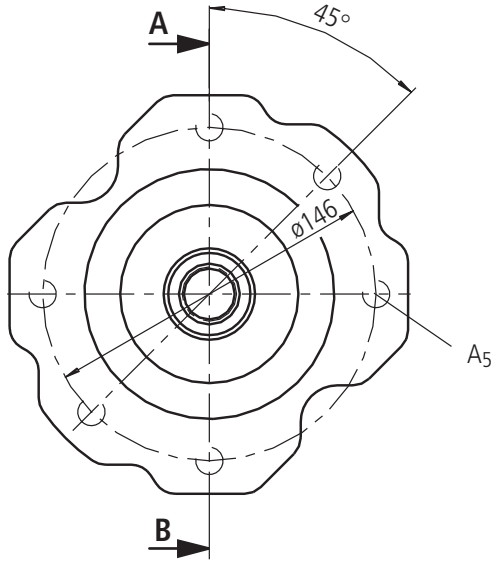

section A - B

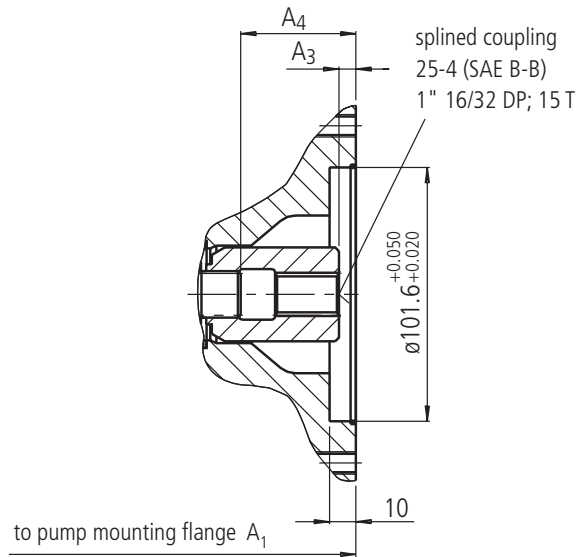

Size main pump	A ₁	A ₃	A ₄	A ₅
28	204	9	47	M12; 15 deep
45	229	9	53,4	M12; 18 deep
71	267	9	61,3	M12; 20 deep
100	338	10	65	M12; 20 deep
140	350	8	77,3	M12; 20 deep

For operation with HF-fluids please consider RE-data sheet of built-on pump.

Flange SAE 127-2 (SAE C) for built-on A10VO 71 (shaft S, see RD 92701)

Order code **K07**

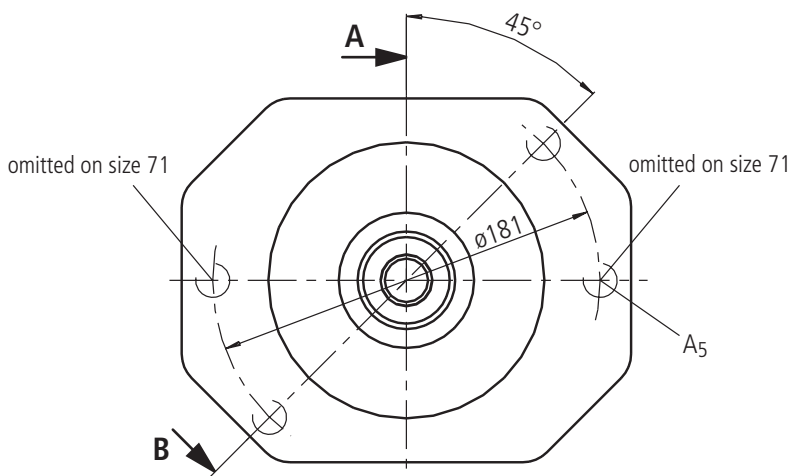

section A - B

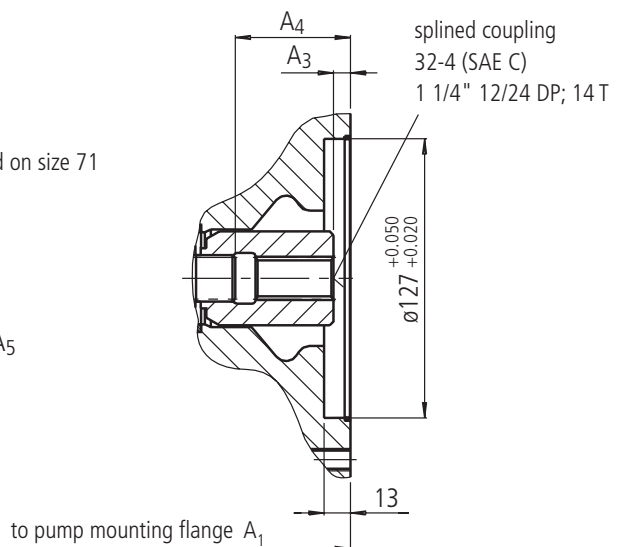

Size main pump	A ₁	A ₃	A ₄	A ₅
71	267	10	61,3	M16; 18 deep
100	339	9	65	M16; 20 deep

For operation with HF-fluids please consider RE-data sheet of built-on pump.

Unit Dimensions Through Drives K24 and K17

Before finishing your design, please request a certified drawing.

Flange SAE 127-2 (SAE C) for built-on A10VO 100 (shaft S, see RD 92701) or internal gear pump PGH5 (shaft R, flange U2, see RD 10223)

Order code **K24**

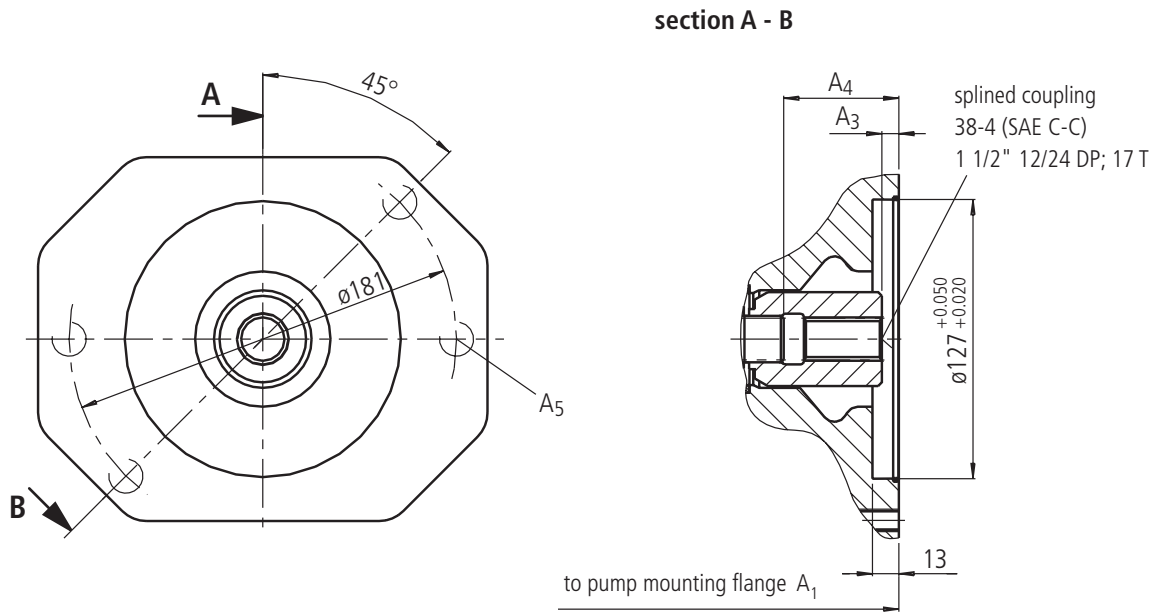

Size main pump	A ₁	A ₃	A ₄	A ₅
100	338	8	65	M16; 20 deep, right through
140	350	9	77,3	M16; 32 deep

For operation with HF-fluids please consider RE-data sheet of built-on pump.

Flange SAE 152-4 (SAE D) for built-on A10VO 140 (shaft S, see RD 92701);

Order code **K17**

main pump size 140

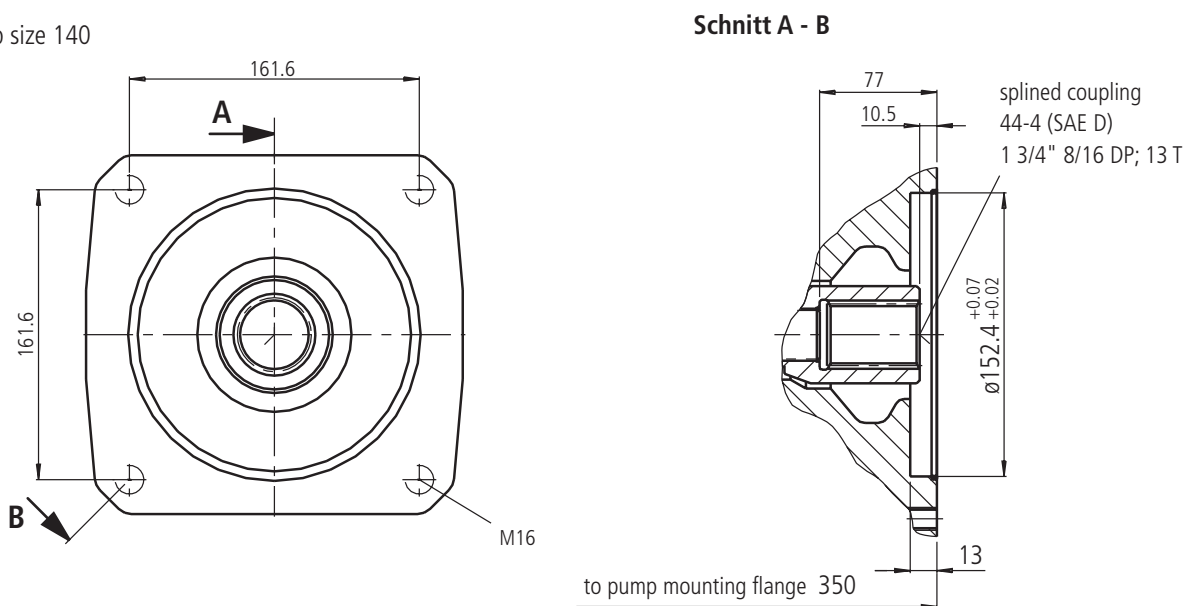

For operation with HF-fluids please consider RE-data sheet of built-on pump.

Unit Dimensions Through Drive K57

Before finishing your design, please request a certified drawing.

Flange metric, 4-hole for built-on radial piston pump R4 (see RD 11263)

Order code **K57**

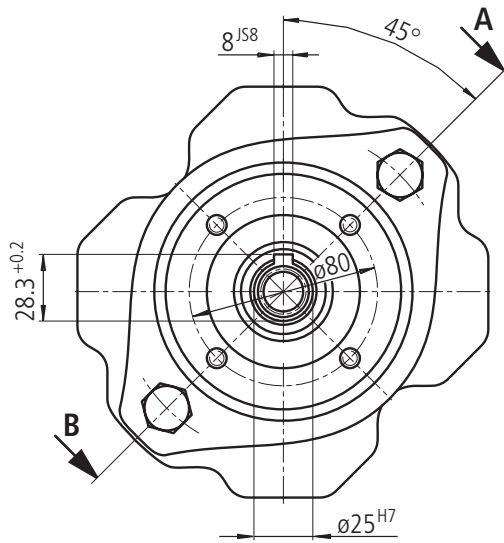

section A - B

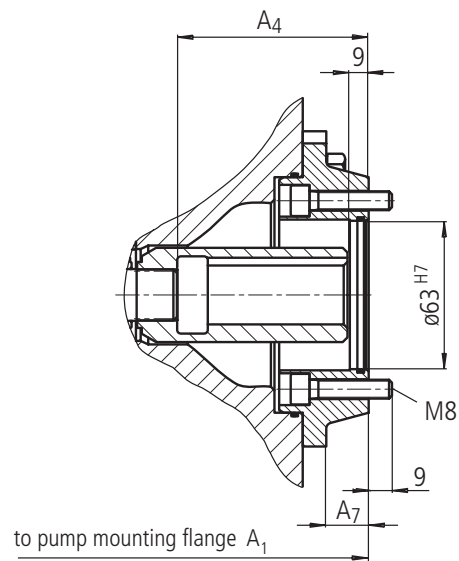

Size main pump	A_1	A_4	A_7
28	233	47	8
45	258	71,5	8
71	283	68	8
100	354	70,5	8
140	366	84	8

For operation with HF-fluids please consider RE-data sheet of built-on pump.

Preferred Types - Shorter Delivery Times

Ident.-No.	Type	Max. torque T	Ident.-No.	Type	Max. torque T
936130	A10VSO 28 DFLR /31R-PPA12N00	25Nm	936207	A10VSO 100 DFLR /31R-PPA12N00	140Nm
936062	A10VSO 28 DFLR /31R-PPA12N00	35Nm	936738	A10VSO 100 DFLR /31R-PPA12N00	200Nm
936059	A10VSO 28 DFLR /31R-PPA12N00	100Nm	936473	A10VSO 100 DFLR /31R-PPA12N00	100Nm
940936	A10VSO 28 DFLR /31R-PPA12N00	70Nm	936790	A10VSO 100 DFLR /31R-PPA12N00	245Nm
939026	A10VSO 28 DFLR /31R-PPA12N00	50Nm	934823	A10VSO 100 DFLR /31R-PPA12N00	120Nm
903160	A10VSO 28 DFR /31R-PPA12N00		944032	A10VSO 100 DFLR /31R-PPA12N00	360Nm
926318	A10VSO 28 DFR1/31R-PPA12K01		943468	A10VSO 100 DFLR /31R-PPA12N00	300Nm
910590	A10VSO 28 DFR1/31R-PPA12N00		939643	A10VSO 100 DFR /31R-PPA12N00	
907919	A10VSO 28 DR /31R-PPA12K01		927083	A10VSO 100 DFR1 /31R-PPA12K02	
903163	A10VSO 28 DR /31R-PPA12N00		922744	A10VSO 100 DFR1 /31R-PPA12N00	
			912007	A10VSO 100 DR /31R-PPA12N00	
936910	A10VSO 45 DFLR /31R-PPA12N00	100Nm	936094	A10VSO 140 DFLR /31R-PPB12N00	300Nm
936912	A10VSO 45 DFLR /31R-PPA12N00	145Nm	935974	A10VSO 140 DFLR /31R-PPB12N00	200Nm
936739	A10VSO 45 DFLR /31R-PPA12N00	120Nm	941109	A10VSO 140 DFLR /31R-PPB12N00	365Nm
935975	A10VSO 45 DFLR /31R-PPA12N00	50Nm	938977	A10VSO 140 DFLR /31R-PPB12N00	245Nm
940582	A10VSO 45 DFLR /31R-PPA12N00	70Nm	943841	A10VSO 140 DFLR /31R-PPB12N00	500Nm
909613	A10VSO 45 DFR /31R-PPA12K01		939192	A10VSO 140 DFR /31R-PPB12N00	
911010	A10VSO 45 DFR /31R-PPA12K26		927126	A10VSO 140 DFR1 /31R-PPB12K02	
939183	A10VSO 45 DFR /31R-PPA12N00		921546	A10VSO 140 DFR1 /31R-PPB12N00	
927068	A10VSO 45 DFR1/31R-PPA12K02		922983	A10VSO 140 DR /31R-PPB12N00	
908725	A10VSO 45 DFR1/31R-PPA12N00		932852	A10VSO 140 DRG /31R-PPB12N00	
907403	A10VSO 45 DR /31R-PPA12N00				
944067	A10VSO 71 DFLR /31R-PPA12N00	100Nm			
944730	A10VSO 71 DFLR /31R-PPA12N00	120Nm			
942654	A10VSO 71 DFLR /31R-PPA12N00	145Nm			
944502	A10VSO 71 DFLR /31R-PPA12N00	70Nm			
948790	A10VSO 71 DFLR /31R-PPA12N00	200Nm			
961216	A10VSO 71 DFLR /31R-PPA12N00	240Nm			
948654	A10VSO 71 DFLR /31R-PPA12N00	156Nm			
945179	A10VSO 71 DFR /31R-PPA12K27				
942635	A10VSO 71 DFR /31R-PPA12N00				
947872	A10VSO 71 DFR1/31R-PPA12K02				
944440	A10VSO 71 DFR1/31R-PPA12N00				
945133	A10VSO 71 DR /31R-PPA12N00				

Please state type and ident-no. when ordering.

Brueninghaus Hydromatik GmbH
Plant Horb
An den Kelterwiesen 14
72160 Horb, Germany
Tel. +49 (0) 74 51-92-0
Fax +49 (0) 74 51-82 21
info.brm@boschrexroth.de
www.boschrexroth.com/brm

© 2002 by Brueninghaus Hydromatik GmbH, 72160 Horb

All rights reserved. No part of this document may be reproduced or stored, processed, duplicated or circulated using electronic systems, in any form or by any means, without the prior written authorization of Brueninghaus Hydromatik GmbH. Violations shall give rise to claims for damages.

The data specified above only serve to describe the product. They do not indicate any specific condition or suitability for a certain application. The information provided does not release the user from the obligation of own judgement and verification. It must be remembered that our products are subject to natural wear and ageing.