

**OPERATING & MAINTENANCE MANUAL
WASCOMAT JUNIOR W 75
WASCOMAT SUPER JUNIOR W 105
WASCOMAT SENIOR W 125
WASCOMAT GIANT W 185**

471 1562-75/04
00.23

WARNING: ALL OPERATING AND MAINTENANCE PROCEDURES SHOWN ON THE NEXT PAGE OF THIS MANUAL MUST BE FOLLOWED DAILY FOR PROPER OPERATION OF YOUR WASCOMAT MACHINE.

PLEASE ENTER THE FOLLOWING INFORMATION AS IT APPEARS ON THE MACHINE(S) DATA PLATE(S).

MACHINE TYPE OR MODEL	
MACHINE SERIAL NUMBER(S)	
ELECTRICAL CHARACTERISTICS: _____ VOLTS, _____ PHASE, _____ HZ.	

MAKE CERTAIN TO KEEP THIS MANUAL IN A SECURE PLACE FOR FUTURE REFERENCE.

**OPERATING & MAINTENANCE MANUAL
WASCOMAT JUNIOR W 75
WASCOMAT SUPER JUNIOR W 105
WASCOMAT SENIOR W 125
WASCOMAT GIANT W 185**

WARNING: ALL OPERATING AND MAINTENANCE PROCEDURES SHOWN ON THE NEXT PAGE OF THIS MANUAL MUST BE FOLLOWED DAILY FOR PROPER OPERATION OF YOUR WASCOMAT MACHINE.

PLEASE ENTER THE FOLLOWING INFORMATION AS IT APPEARS ON THE MACHINE(S) DATA PLATE(S).

MACHINE TYPE OR MODEL	
MACHINE SERIAL NUMBER(S)	
ELECTRICAL CHARACTERISTICS: _____ VOLTS, _____ PHASE, _____ HZ.	

MAKE CERTAIN TO KEEP THIS MANUAL IN A SECURE PLACE FOR FUTURE REFERENCE.



NOTICE TO: OWNERS, OPERATORS AND DEALERS OF WASCOMAT MACHINES

IMPROPER INSTALLATION AND INADEQUATE MAINTENANCE, POOR HOUSEKEEPING AND WILLFUL NEGLECT OR BYPASSING OF SAFETY DEVICES MAY RESULT IN SERIOUS ACCIDENTS OR INJURY. TO ASSURE THE SAFETY OF CUSTOMERS AND/OR OPERATORS OF YOUR MACHINE, THE FOLLOWING MAINTENANCE CHECKS MUST BE PERFORMED ON A DAILY BASIS.

NOTICE À L'ATTENTION DES PROPRIÉTAIRES, UTILISATEURS ET REVENDEURS DE MACHINES WASCOMAT

UNE INSTALLATION INCORRECTE ET UN ENTRETIEN INADÉQUAT, DE MÊME QUE LA NÉGLIGENCE OU LA NEUTRALISATION DÉLIBÉRÉES DES DISPOSITIFS DE SÉCURITÉ, PEUVENT ÊTRE CAUSES DE BLESSURES OU D'ACCIDENTS SÉRIEUX. POUR ASSURER LA SÉCURITÉ DES CLIENTS ET/OU DES UTILISATEURS DE VOTRE MACHINE, IL EST INDISPENSABLE DE PROCÉDER CHAQUE JOUR AUX CONTRÔLES DE ROUTINE CI-APRÈS.

1. Prior to operation of the machine, check to make certain that all operating instructions and warning signs are affixed to the machine and legible. (See the following page of this manual for description and location of the signs.) Missing or illegible ones must be replaced immediately. Be sure you have spare signs and labels available at all times. These can be obtained from your dealer or Wascomat.
2. Check the door safety interlock, as follows:
 - (a) OPEN THE DOOR of the machine and attempt to start in the normal manner:
For coin-operated models, insert the proper coins to start the machine.
For manually operated models, place the ON-OFF switch in the ON position and press the Start switch.

THE MACHINE(S) MUST NOT START !

- (b) CLOSE THE DOOR to start machine operation and, while it is operating, attempt to open the door without exerting extreme force on the door handle. The door should remain locked!

If the machine can start with the door open, or can continue to operate with the door unlocked, the door interlock is no longer operating properly. The machine must be placed out of order and the interlock immediately replaced.
(See the door interlock section of the manual.)
3. DO NOT UNDER ANY CIRCUMSTANCES ATTEMPT TO BYPASS OR REWIRE ANY OF THE MACHINE SAFETY DEVICES AS THIS CAN RESULT IN SERIOUS ACCIDENTS.
4. **Be sure to keep the machine(s) in proper working order:** Follow **all** maintenance and safety procedures. Further information regarding machine safety, service and parts can be obtained from your dealer or from Wascomat through its Teletech Service Hotline - 516/371-0700.

All requests for assistance must include the model, serial number and electrical characteristics as they appear on the machine identification plate. Insert this information in the space provided on the previous page of this manual.

5. **WARNING:** DO NOT OPERATE MACHINE(S) WITH SAFETY DEVICES BYPASSED, REWIRED OR INOPERATIVE! DO NOT OPEN MACHINE DOOR UNTIL DRUM HAS STOPPED ROTATING!

AVERTISSEMENT: NE PAS FAIRE FONCTIONNER LA (LES) MACHINE(S) AVEC UN DISPOSITIF DE SÉCURITÉ NEUTRALISÉ, RECÂBLÉ OU NON OPÉRATIONNEL! NE PAS OUVRIR LA MACHINE TANT QUE LE TAMBOUR NE S'EST PAS IMMOBILISÉ!



SAFETY AND WARNINGS SIGNS

Replace If Missing Or Illegible

One or more of these signs must be affixed on each machine as indicated, when not included as part of the front instruction panel.

LOCATED ON THE OPERATING INSTRUCTION SIGN OF THE MACHINE:

CAUTION

1. Do not open washer door until cycle is completed, operating light is off, and wash cylinder has stopped rotating.
2. Do not tamper with the door safety switch or door lock.
3. Do not attempt to open door or place hands into washer to remove or add clothes during operation. This can cause serious injury.

PRECAUCION

1. No abra la puerta de la máquina lavadora sino hasta que la máquina haya terminado su ciclo, la luz operativa esté apagada y el cilindro de lavado haya completamente terminado de girar.
2. No interfiera o manipule el switch o la cerradura de la puerta.
3. No trate de abrir la puerta o meta las manos dentro de la máquina para meter o sacar ropa mientras la máquina está en operación, pues puede resultar seriamente herido.

MACHINE SHOULD NOT BE USED BY CHILDREN

LAS MÁQUINAS NO DEBEN SER USADAS POR NIÑOS

LOCATED AT THE REAR OF THE MACHINE:

INSTALLATION AND MAINTENANCE WARNINGS

1. This machine **MUST** be securely bolted according to the installation instruction to reduce the risk of fire and to prevent serious injury, or damage to the machine.
Pour réduire les risques d'incendie, fixer cet appareil sur un plancher beton sans revêtement.
2. If installed on a floor of combustible material, the floor area below this machine must be covered by a metal sheet extending to the outer edges of the machine.
3. This machine **MUST** be connected to a dedicated electrical circuit to which no other lightning unit or general purpose receptacle is connected. Use copper conductor only.
Utiliser seulement des conducteurs en cuivre.
4. This machine **MUST** be serviced and operated in compliance with manufacturer's instructions. **CHECK DOOR LOCKS EVERY DAY FOR PROPER OPERATION TO PREVENT INJURY OR DAMAGE. IF THE DOOR LOCK FAILS TO OPERATE PROPERLY, PLACE THE MACHINE OUT OF ORDER UNTIL THE PROBLEM IS CORRECTED.**
5. Disconnect power prior to servicing of machine.
Deconnecter cet appareil del'alimentation avant de proceder a l'entretien.
6. To remove top panel, first remove screws at the rear. When remounting the top, reinstall them. To remove the top panel on models on which it is secured by one or two keylocks, use the keys originally shipped in the drum package. Be certain to relock after remounting the top panel.

MANUFACTURED BY WASCATOR
DISTRIBUTED BY WASCOMAT INWOOD, NEW YORK, USA

471 7662-02

LOCATED ON THE DOOR:

If you need to order more safety or warning signs, call Wascomat's parts department at 516-371-2000, or call your local dealer.

WARNING !

DO NOT ATTEMPT TO OPEN DOOR UNTIL PROGRAM HAS FINISHED AND DRUM HAS STOPPED ROTATING.

471 7661-17

Wascomat Junior W 75 • Wascomat Super Junior W 105 Wascomat Senior W 125 • Wascomat Giant W 185

Contents

Introduction	1
Technical data	2
Installation	7
Safety rules	14
Operating instructions	15
Wash programs	16
Mechanical and electrical design	22
Maintenance	40
Trouble-shooting	41

The manufacturer reserves the right to make changes to design and material specifications.

Safety instructions

- The machine is designed for water washing only.
- The machine must not be used by children.
- All installation operations are to be carried out by qualified personnel. Licensed personnel are necessary for all electric power wiring.
- The interlock of the door must be checked daily for proper operation and must not be bypassed.
- All seepage in the system, due to faulty gaskets etc., must be repaired immediately.
- All service personnel must be fully familiar with the operating manual before attempting any repair or maintenance of the machine.
- The machine must not be sprayed with water, otherwise short circuiting may occur.
- Fabric softeners with volatile or inflammable fluids are not to be used in the machine.

Consignes de sécurité

- La machine est conçue pour le lavage à l'eau exclusivement.
- La machine ne peut être utilisée par des enfants.
- Tous les travaux d'installation doivent être effectués par une personne qualifiée. Tous les câblages électriques doivent être réalisés par un électricien diplômé.
- Le verrouillage du hublot doit être vérifié chaque jour et ne peut être neutralisé.
- Toute fuite du système, due à des joints défectueux etc., doit être réparée sans délai.
- Tous les membres du personnel d'entretien doivent être parfaitement familiarisés avec le manuel d'entretien avant d'entreprendre une réparation ou un entretien de la machine.
- Ne jamais asperger d'eau la machine sous peine de risquer un court-circuit.
- Ne pas utiliser dans la machine des adoucissants textiles contenant des liquides volatils ou inflammables.

Introduction

Fig. 1 The Wascomat Junior, Super Junior, Senior and Giant models washer/extractors have been developed to cover the heavy duty and various size requirements of coin laundries, apartment houses, hotels, motels, nursing homes, hospitals, professional laundries, restaurants, schools, colleges and all on-premises laundries where high quality automatic washing and quick formula variation are required.

The W models offer four pre-set wash programs Hot, Warm, Cold and Delicate which can be selected by turning the rotary program selector on the front panel. These programs are designed to suit a variety of fabrics and offer different water temperature programs. The machine is designed for connection to hot and cold water supplies.

All parts of the machine which come into contact with the items being washed are made of heavy gauge surgical stainless steel, ensuring long life and lasting beauty, as well as full protection for no-iron fabrics. All electrical components are made accessible for servicing by simply removing the top panel.

This manual contains a technical description of the Wascomat W75, W105, W125 and W185 model machines and instructions for their installation, operation and maintenance. Together with the wiring diagram which accompanies each individual machine it should be kept in a safe place for easy reference.

When ordering spare parts always give the machine serial number, model, voltage and other electrical characteristics appearing on the nameplate at the rear of the machine.

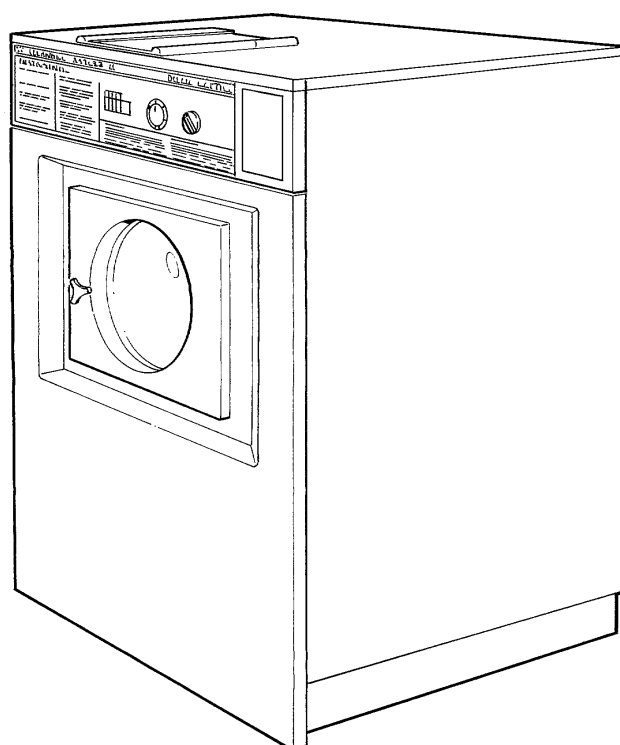
1

Technical data

Technical data Wascomat Junior W75

Dry load capacity	up to	7.5 kg	18 lbs
Overall dimensions	Width	660 mm	26 in
	Depth (at the top)	593 mm	23 3/8 in
	Height	1050 mm	41 5/16 in
Inner drum	Diameter	520 mm	20 1/2 in
	Depth	356 mm	14 in
	Volume	75 litre	2.7 cu.ft
Speed of rotation	Wash		54 r.p.m.
	Extraction		543 r.p.m.
G-factor	During wash		0.8
	During extraction		90
Floor loading	Net weight	107 kg	235 lbs
	Dyn force	1.2±2.6 kN	290±620 lbs. force
Motor speed	During wash		360 r.p.m.
	During extraction		3380 r.p.m.
Rated output power	Motor, wash, 3-phase		110 W 0.15 HP
	Motor, extract., 3-phase		550 W 0.75 HP
	Motor, wash, 1-phase		110 W 0.15 HP
	Motor, extract., 1-phase		370 W 0.5 HP
Voltage requirements	Choice:		
	120 V 1-phase 60 Hz		
	or 208-240 V 3-Phase 60 Hz		
Overcurrent protection	Three-phase		15 A
	Single-phase		20 A

Water connections

Recommended water pressure	2-6 kp/cm ²	25-85 psi
Hose connection, water	20 DN	3/4 in
Hose connection, drain	74 mm	3 in

Technical data Wascomat Super Junior W105

Dry load capacity	up to	11.5 kg	25 lbs
Overall dimensions	Width	660 mm	26 in
	Depth (at the top)	710 mm	27 5/16 in
	Height	1135 mm	44 11/16 in
Inner drum	Diameter	520 mm	20 1/2 in
	Depth	473 mm	18 5/8 in
	Volume	100 litre	3.6 cu.ft
Speed of rotation	Wash		54 r.p.m.
	Extraction		543 r.p.m.
G-factor	During wash		0.8
	During extraction		90
Floor load	Net weight	161 kg	355 lbs
	Dyn force	1.7 ±3.4 kN	408±816 lbs. force
Motor speed	During wash		360 r.p.m.
	During extraction		3450 r.p.m.
Rated output power	Motor, wash 3-phase		150 W 0.2 HP
	Motor, extract. 3-phase		900 W 1.2 HP
	Motor, wash 1-phase		140 W 0.18 HP
	Motor, extract. 1-phase		550 W 0.75 HP
Voltage requirements	Choice:		
	120 V 1-phase 60 Hz		
	or		
	208-240 V 3-Phase 60 Hz		
Overcurrent protection	Three-phase		15 A
	Single-phase		20 A
Water connections			
Recommended water pressure	2-6 kp/cm ²		25-85 psi
Hose connection, water	20 DN		3/4"
Hose connection, drain	74 mm		3"

Technical data

Technical data Wascomat Senior W125

Dry load capacity	up to	16 kg	35 lbs
Overall dimensions	Width	745 mm	29 5/16 in
	Depth (at the top)	915 mm	36 in
	Height	1196 mm	47 1/16 in
Inner drum	Diameter	620 mm	24 1/2 in
	Depth	520 mm	20 1/2 in
	Volume	157 litre	5.65 cu.ft
Speed of rotation	Wash		52 r.p.m.
	Extraction		500 r.p.m.
G-factor	During wash		0.9
	During extraction		87
Floor load	Net weight	210 kg	462 lbs
	Dyn force	2.4±4.8 kN	576±1152 lbs. force
Motor speed	During wash		360 r.p.m
	During extraction		3450 r.p.m
Rated output power	Motor, wash 3-phase		300 W 0.4 HP
	Motor, extract. 3-phase		1300 W 1.8 HP
	Motor, wash 1-phase		280 W 0.4 HP
	Motor, extract. 1-phase		1300 W 1,8 HP
Voltage requirements	Choice:		
	208-240 V 1-phase 60 Hz		
	or		
	208-240 V 3-Phase 60 Hz		
Overcurrent protection	Three-phase	15 A	
	Single-phase	20 A	
Water connections			
Recommended water pressure	2-6 kp/cm ²		25-85 psi
Hose connection, water	20 DN		3/4"
Hose connection, drain	74 mm		3"

Technical data Wascomat Giant W 185

Dry load capacity	up to	23 kg	50 lbs	
Overall dimensions	Width	827 mm	32 9/16 in	
	Depth (at the top)	960 mm	37 13/16 in	
	Height	1315 mm	51 3/4 in	
Inner drum	Diameter	700 mm	27 9/16 in	
	Depth	600 mm	23 5/8 in	
	Volume	230 litre	8.1 cu.ft	
Speed of rotation	Wash		45 r.p.m.	
	Extraction		455 r.p.m.	
G-factor	During wash		0.8	
	During extraction		81	
Floor load	Net weight	264 kg	582 lbs	
	Dyn force	3.1±5.2 kN	744±1248 lbs. force	
Motor speed	During wash		360 r.p.m	
	During extraction		3480 r.p.m	
Rated output power	Motor, wash 3-phase		400 W 0.55 HP	
	Motor, extract. 3-phase		2000 W 2.7 HP	
	Motor, wash 1-phase		400 W 0.55 HP	
	Motor, extract. 1-phase		1800 W 2.4 HP	
Voltage requirements	Choice:			
	208-240 V 1-phase 60 Hz			
	or			
	208-240 V 3-Phase 60 Hz			
Overcurrent protection	Three-phase	15 A		
	Single-phase	20 A		
Water connections				
Recommended water pressure	2-6 kp/cm ²		25-85 psi	
Hose connection, water	20 DN		3/4"	
Hose connection, drain	74 mm		3"	

Outline and dimensions

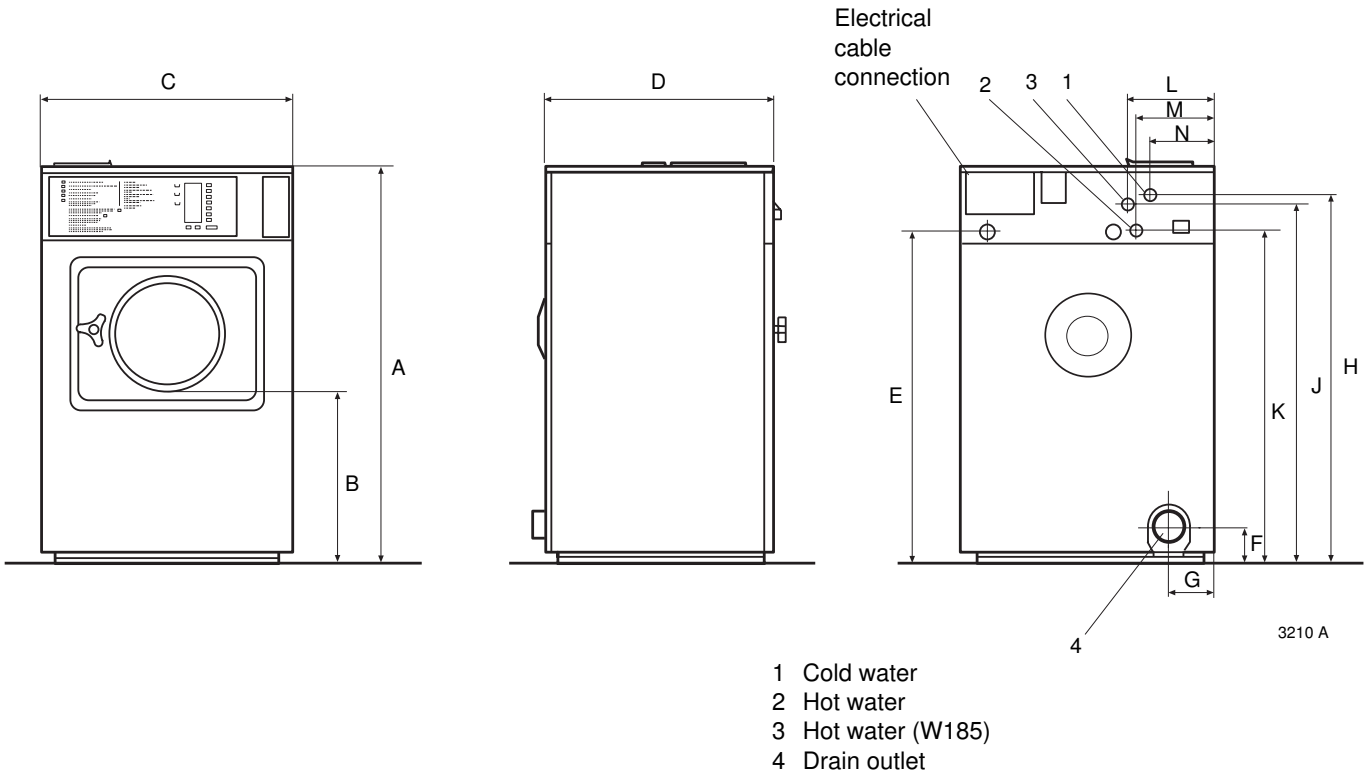

	W75		W105		W125		W185	
	mm	inches	mm	inches	mm	inches	mm	inches
A	1050	41 5/16	1135	44 11/16	1196	47 1/16	1315	51 3/4
B	437	17 3/16	522	20 9/16	465	18 5/16	540	21 1/4
C	660	26	660	26	745	29 5/16	827	32 9/16
D	593	23 3/8	710	27 15/16	915	36	960	37 13/16
E	895	35 1/4	980	38 9/16	1040	40 15/16	1160	45 11/16
F	100	3 15/16	185	7 5/16	100	3 15/16	100	3 15/16
G	125	4 15/16	125	4 15/16	270	10 5/8	260	10 1/4
H	980	38 9/16	1065	41 15/16	1130	44 11/16	1255	49 7/16
J	–	–	–	–	–	–	1215	47 13/16
K	890	35	975	38 3/8	1035	40 3/4	1155	45 1/2
L	–	–	–	–	–	–	295	11 5/8
M	205	8 1/6	205	8 1/16	205	8 1/16	205	8 1/16
N	160	6 5/16	160	6 5/16	160	6 5/16	160	6 5/16

Installation

Machine foundation

The machines are designed to be bolted in position to a concrete floor or specially prepared concrete foundation. A template showing the size of the foundation and positioning of the foundation bolts can be provided by Wascomat.

For installation on an existing concrete floor, the floor must be at least 8" thick and of good quality. If the floor does not meet these requirements, then a 6-8" high concrete foundation should be made. A prefabricated steel base is available for mounting of machines without an additional foundation.

Follow the instructions below when making a concrete foundation:

Fig. 2 1. Decide where to place the machine and consider maintenance requirements, i.e. determine a suitable distance from the rear of the foundation to the wall, and the distance from the foundation to the nearest side wall. The distance should be at least 16 and 12 inches, respectively.

Fig. 3 2. Break up the floor to a depth of 3 inches, making sure that the sides of the hole slope inwards - the bottom of the hole should be 5 inches longer than the upper length.
3. Wet the hole well. Brush the bottom and sides with cement grout.
4. Prepare a casing and fill with 3,000 PSI min. concrete to form a pad. Make sure the foundation is level.

Fig. 4 5. Use the template to position the foundation bolts correctly - bolts are to extend 1 1/2" above concrete.

NOTE: A prefabricated steel frame, designed to be placed in the concrete instead of the individual mounting bolts, is available from Wascomat.

	W75		W105		W125		W185	
	mm	inches	mm	inches	mm	inches	mm	inches
A	364	14 5/16	481	18 15/16	508	20	600	23 5/8
B	593	23 3/8	710	27 15/16	915	36	960	37 13/16
C	643	25 5/16	760	29 15/16	965	38	1010	39 3/4
D	100	4	100	4	115	4 1/2	115	4 1/2
E	530	20 7/8	530	20 7/8	600	23 5/8	700	27 9/16
G	700	27 9/16	700	27 9/16	815	32 1/16	900	35 7/16
H	643	25 5/16	715,6	28 3/16	786	30 15/16	922	36 1/8
I	-	-	-	-	991	39	1090	42 7/8
K	-	-	-	-	281	11	236	9 5/16

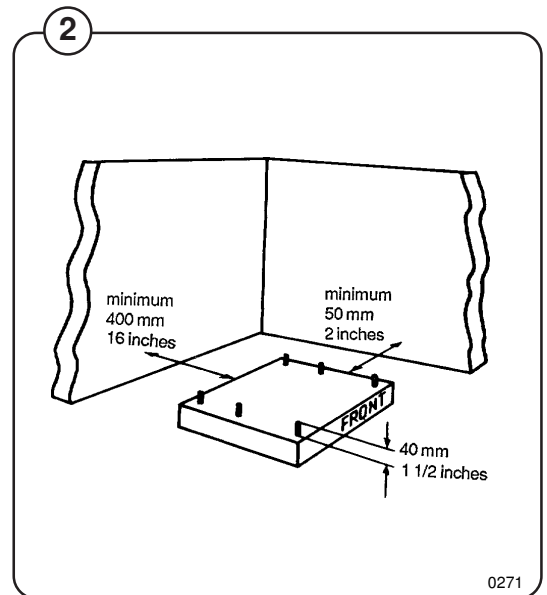

0271

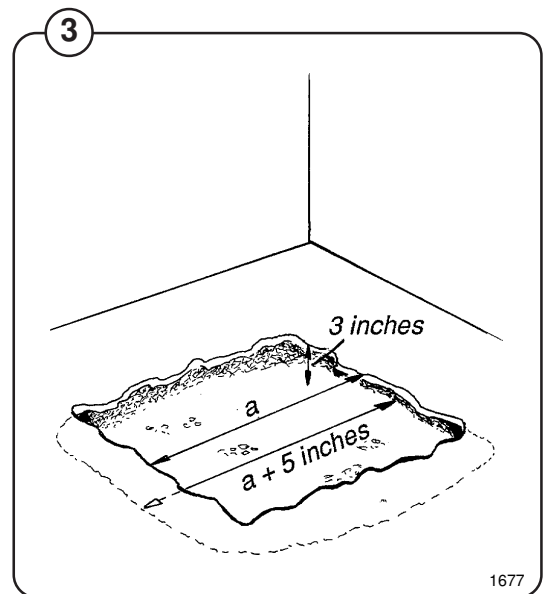

1677

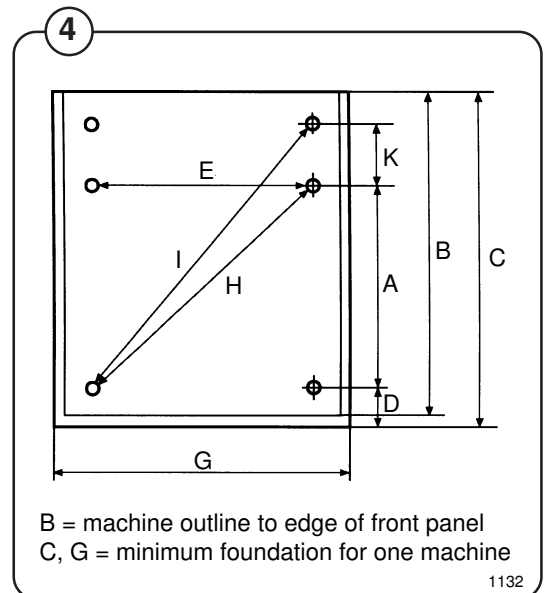

B = machine outline to edge of front panel
C, G = minimum foundation for one machine

1132

Mechanical installation

- Fig. 5
- Place wide steel shims on the concrete foundation over the bolts.
 - Lift the machine and lower it in position. **Never** use the door or the door handle to lift or lower the machine.
 - Check that the machine is level front-to-rear and side-to-side and standing firmly on the four (W75, W105) or six (W125 W185) supporting points. Spacing washers must be mounted if one or more of these points is not resting against the floor/foundation.
- Fig. 6
- Place flat washers over the foundation bolts and secure the machine in position by tightening the self-locking nuts. See illustration below.
- Fig. 7
- Check and tighten the nuts every week for the first month to compensate for any setting of the foundation.

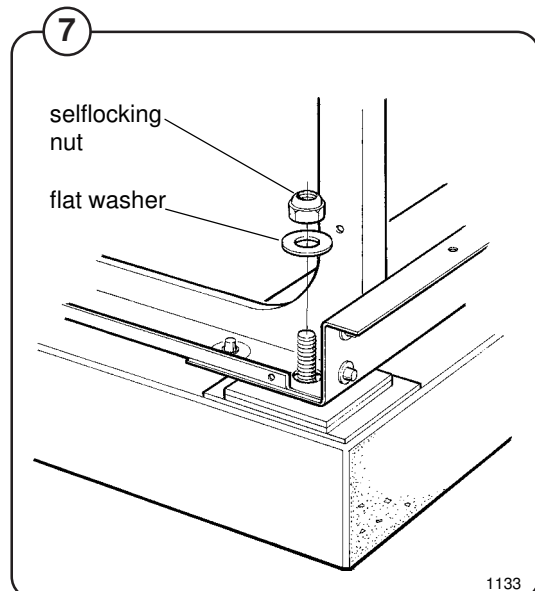
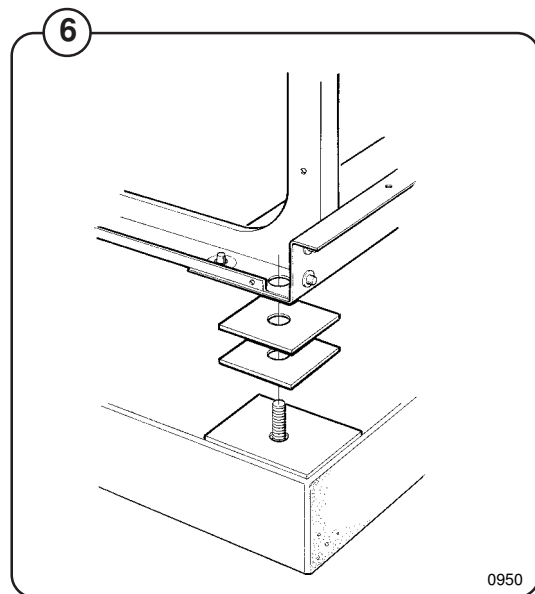
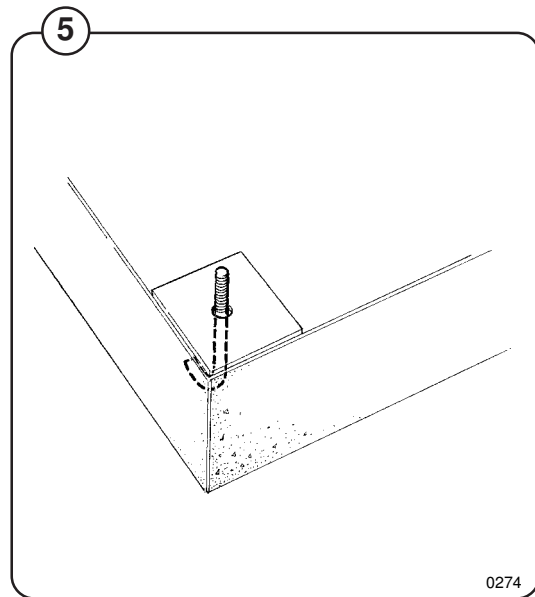

Electrical installation



All electrical installations are to be carried out by licenced personnel.

Although the machines are equipped with thermal overloads in the motor windings a separate three-phase common-trip circuit breaker must be installed for all three-phase machines.

Fig. 8

For proper overcurrent protection, check the data plate at the rear of the machine. Also consult local electrical code for special requirements.

Use inverse-time circuit breaker only.

Fig. 9

Connect L1, L2, L3 and ground wires according to the markings of the terminal block at the upper left rear corner of the machine. The cable is to hang in a large loose loop, supported by the clip of the terminal block.

After installation, do the following for 3-phase machines:

Check the incoming power for a high voltage or "stinger" leg. This will usually measure higher than 150 Volts to ground. If present, connect that line to L2 on the terminal block.

Fig. 10

For 3-phase machines start the machine and check that the drum rotates in the ccw direction during extraction, when seen from the front. If the drum rotates in the wrong direction interchange lines L1 and L3 at the power connection terminals.

Fig. 10

Recommended overcurrent protection

W75	3-phase	– 15 A max
W75	1-phase	– 20 A max
W105	3-phase	– 15 A max
W105	1-phase	– 20 A max
W125	3-phase	– 15 A max
W125	1-phase	– 20 A max
W185	3-phase	– 15 A max
W185	1-phase	– 20 A max

Signals for external supply (non-metered machines).

At the rear of the machine, next to the incoming lower terminal block, there is another terminal block for connection of signal wires to an external supply dispenser. The connection points are marked 1, 2, 3 and C (common).

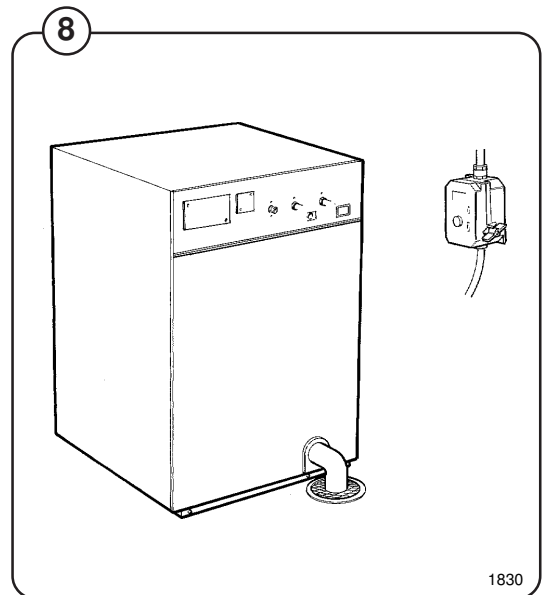

1830

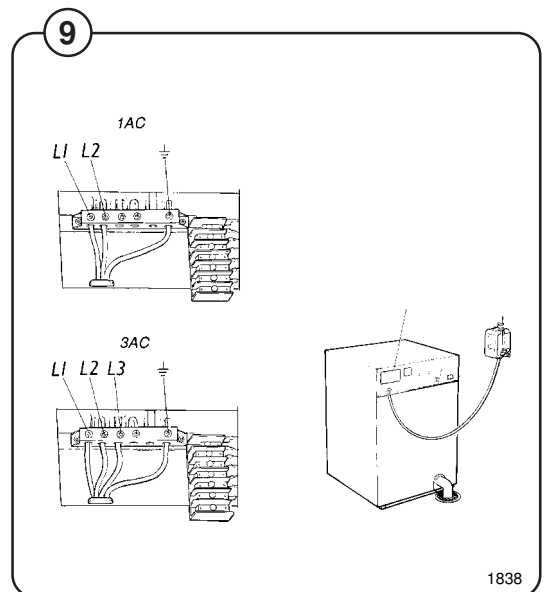

1838

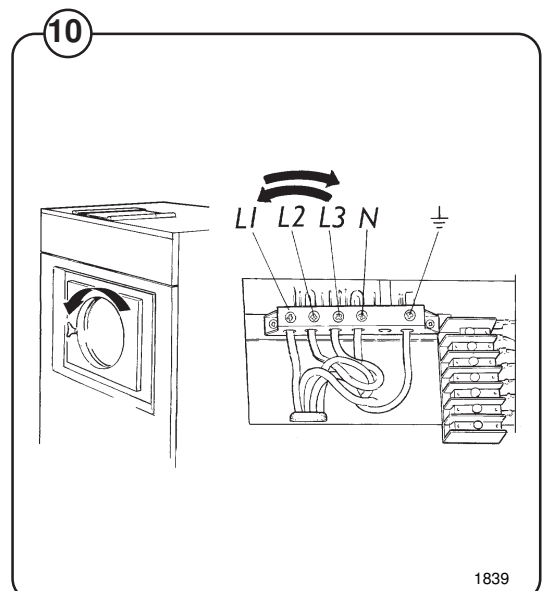

1839

Water connections

NOTE

All plumbing must conform to national and local plumbing codes.

Fig. 11 Incoming water lines should not require non-return or back-suction valves, as the machine is already equipped with backflow prevention. Shut-off valves must be provided on all incoming water lines.

Fig. 12

- Water inlets are labelled for hot and cold water connection.

- Before connecting the water hoses flush the water lines thoroughly and check that the filter at the machine inlet is fitted correctly. This is essential since dirt and grit in the water lines may clog the inlet valve filter screens and/or drain pilot valve, causing the machine to fill very slowly or the drain valve not to operate properly.

Fig. 13

- Connect the water supply to the machine with 3/4" reinforced rubber hosing not to exceed 6 ft in length. Hang the hosing in a large loop. Do not use rigid piping.
- Never force a hose onto the threads or you may cause cross-threading and leaks. If this occurs, place the threaded portion of the hose over the valve threads and push forward firmly, to catch the next thread. Then tighten.

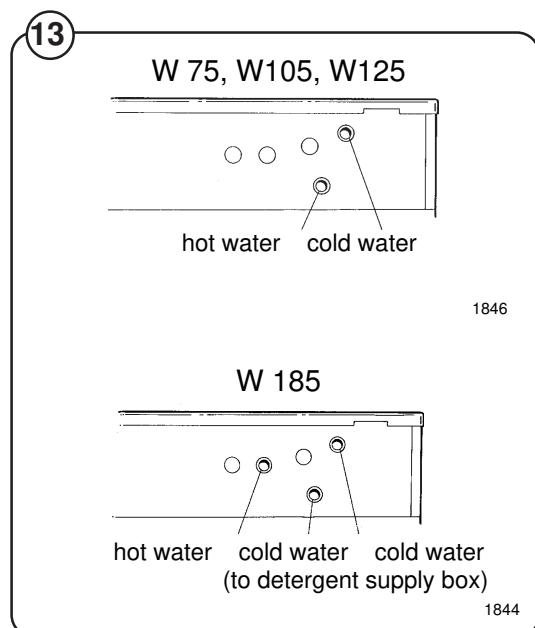
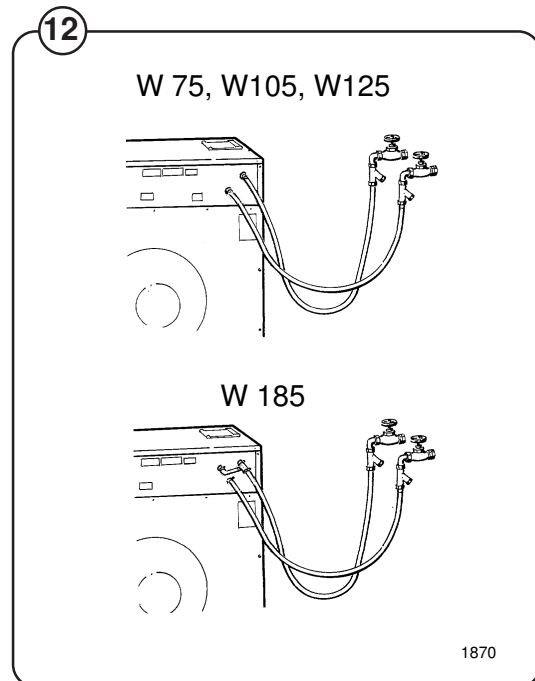
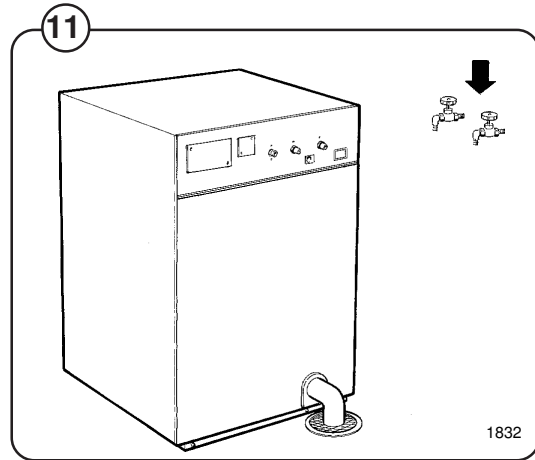

Drain connection

Fig. Connect a 3" (75 mm) flexible drain hose to the drain outlet of the machine.

14

The drain hose may be connected to a 2" to 3" T-connection coming out of your main drain line, which is typically four inches diameter, or the washer may dump into a trough which slopes to a drain, or directly into a floor drain as shown in the illustration. Check local codes for required installation procedure.

The drain hose must not have sharp bends and must slope from the machine to assure proper drainage. If the machine(s) drain into an open trough the trough should have a slope of 1/8"-1/4" per foot towards the main drain.

Note:

To simplify installation, Wascomat has made available the following hose kits:

For W75, W105 and W125 Partno. 002008

For W185 Partno. 002009

These kits contain inlet hoses, drain hose, hose clamps and washers.

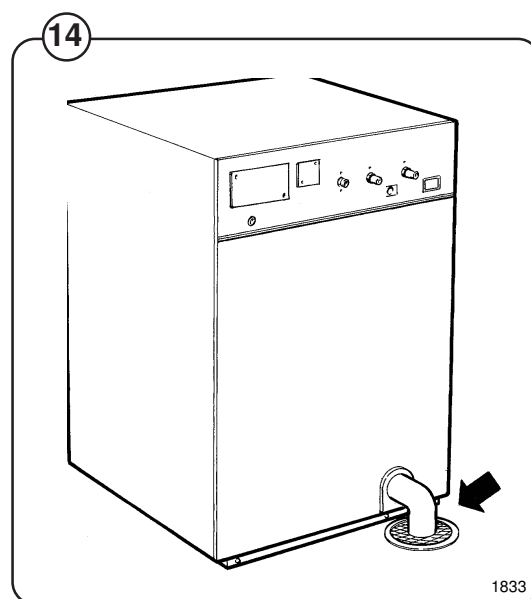

Before the machine is operated, the door safety interlock must be checked for proper operation as follows:

Fig.

15

- When washer loading door is open, the machine must not start. Verify this by attempting to start washer with door open.

Fig.

16

- When washer is in operation, the loading door is locked and cannot be opened. Verify this by attempting to open the loading door when the machine is operating. If necessary, consult this manual for proper operation of the door lock and door safety interlock or call a qualified serviceman.

IMPORTANT:

Door safety interlock must be checked daily in accordance with above procedure.

WARNING:

Before servicing Wascomat equipment, disconnect electrical power.

IMPORTANT:

Le verrouillage de sûreté de la porte doit être vérifié tous les jours selon la procédure ci-dessus.

AVERTISSEMENT:

Couper l'alimentation électrique avant tous travaux d'entretien sur un appareil Wascomat.

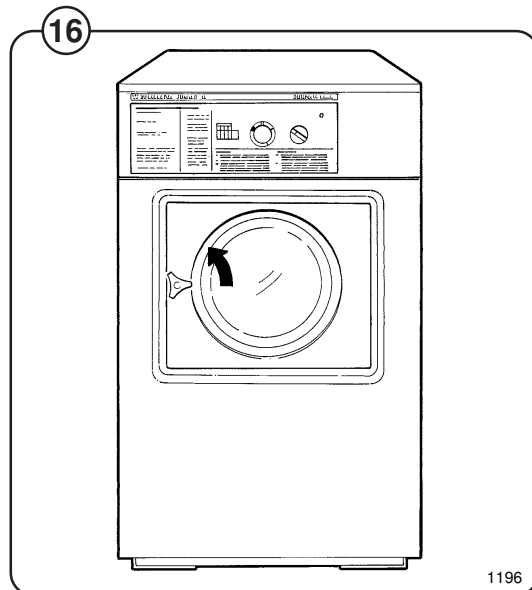
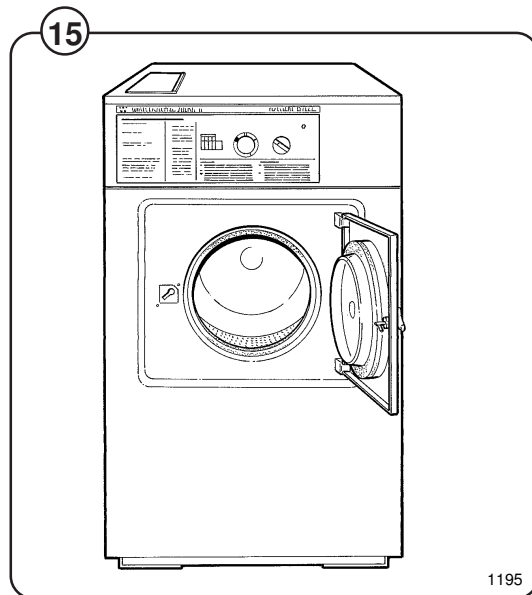

Function control check-out list

In the machine cylinder, you will find the warranty registration card, a copy of the warranty policy and other pertinent materia. The warranty card should be completed and sent to Wascomat. All other items should be placed in a safe place for future reference.

The machine should be cleaned when the installation is completed, and checked out as detailed below without loading the machine with fabrics:

1. Check the incoming power for proper voltage, phase and cycles.
2. Open manual shut-off valves to the machine.
3. Turn on electric power.
4. Check the function of the door safety interlock as detailed on page 10 of this manual.

Fig. 17

5. Select the HOT program and start the machine.
6. Run through a complete cycle, checking for water temperature, drain operation and extract direction.

Fig. 18

7. When the program is in the Prewash cycle, hot and cold water should be entering the machine. In the Wash cycle only hot water should enter.

Fig. 19

8. If cold water comes in, the hoses are improperly connected. Reverse hot and cold water hoses.

Fig. 20

9. Machine must spin in a counter-clockwise direction, as seen from the front, during extraction. If it does not, reverse lines L1 and L3 on 3-phase machines.

If the side panels of the washer move during extraction, remove the shipping security which connects the top rear of the cylinder to the upper section of the back panel. It is used to prevent shipping damage but has no function when the washer is installed in a laundry. In some rare installations this bracket may transmit vibrations to the side panels. If it does, remove the shipping security; otherwise, leave it in place.

NOTE

All machines are factory tested prior to shipment. Occasionally, some residual water may be found when the machine is installed.

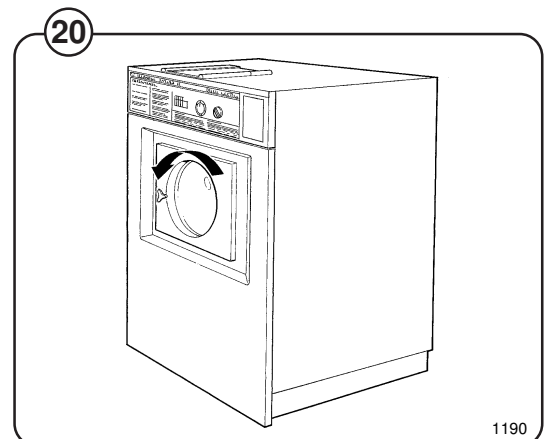
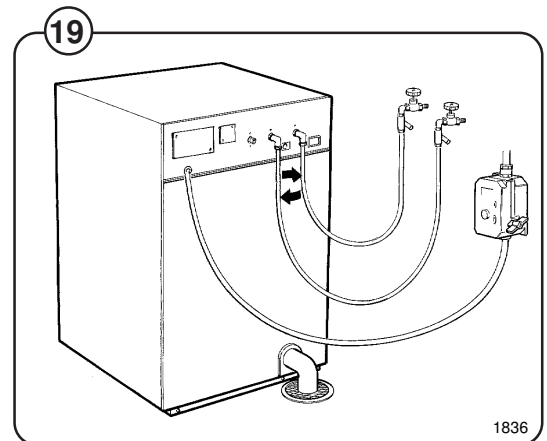
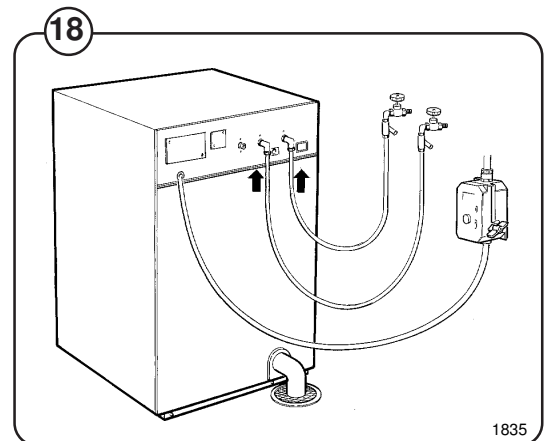
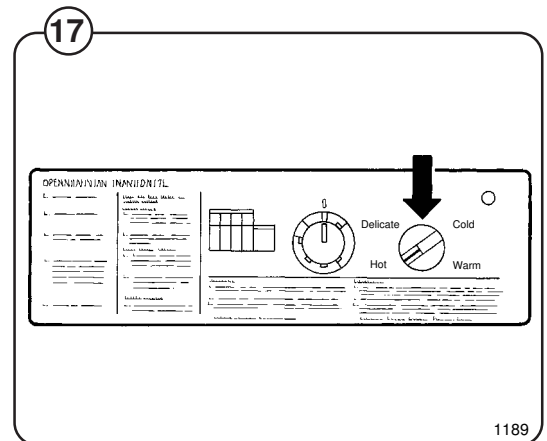

Safety rules

- This machine is designed for water washing only.
- All installation operations are to be carried out by qualified personnel. Licensed personnel are necessary for all electric power wiring.
- The interlock of the door must be checked daily for proper operation and must not be bypassed.
- All seepage in the system, due to faulty gaskets etc., must be repaired immediately.
- All service personnel must be fully familiar with the operating manual before attempting any repair or maintenance of the machine.
- This machine must not be sprayed with water, otherwise short circuiting may occur.
- This machine must not be used by children.
- Fabrics softener with volatile or inflammable fluids are not to be used in the machine.

Consignes de sécurité

- La machine est conçue pour le lavage à l'eau exclusivement.
- Tous les travaux d'installation doivent être effectués par une personne qualifiée. Tous les câblages électriques doivent être réalisés par un électricien diplômé.
- Le verrouillage du hublot doit être vérifié chaque jour et ne peut être neutralisé.
- Toute fuite du système, due à des joints défectueux etc., doit être réparée sans délai.
- Tous les membres du personnel d'entretien doivent être parfaitement familiarisés avec le manuel d'entretien avant d'entreprendre une réparation ou un entretien de la machine.
- Ne jamais asperger d'eau la machine sous peine de risquer un court-circuit.
- La machine ne peut être utilisée par des enfants.
- Ne pas utiliser dans la machine des adoucissants textiles contenant des liquides volatils ou inflammables.

Procedure for use

Preparation

Sort the laundry according to the washing instructions on garment tags.

Empty pockets and close zippers.

Open door, put laundry in the machine and close door.

Start

Fig. 21 Turn the control knob to the desired wash program.

Add detergent and fabric softener in the compartments on top of the machine:

- Fig. 22**
- pre-wash detergent in compartment 1
 - regular detergent in compartment 2
 - liquid fabric softener in compartment 3

Follow dosage instructions on the detergent package.

Liquid detergent can only be added at the beginning of the specific cycle.

Insert coins or tokens. When the right amount has been added the machine starts automatically.

Finishing

When the wash program is finished, open the door and take out the laundry.

Leave the door open when the machine is not in use.

Leave the machine in the condition you would expect to find it in.

Fig. 23 When necessary, clean the door gasket and detergent compartments. Wipe off the machine with a damp cloth.

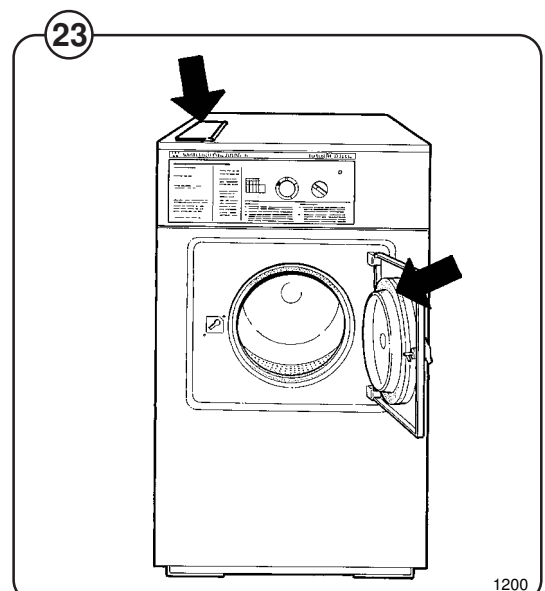
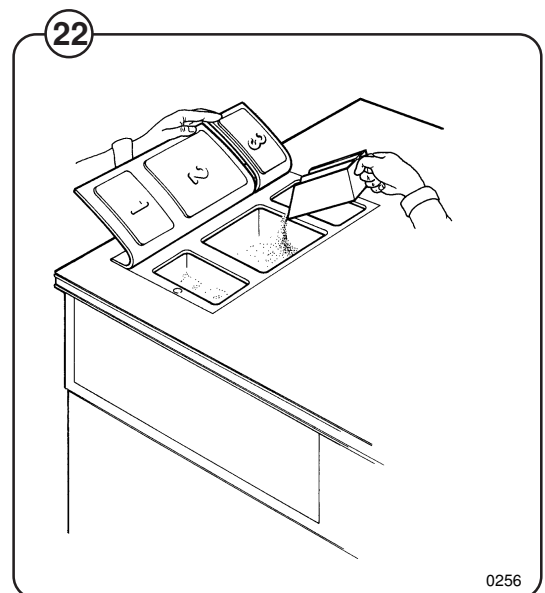
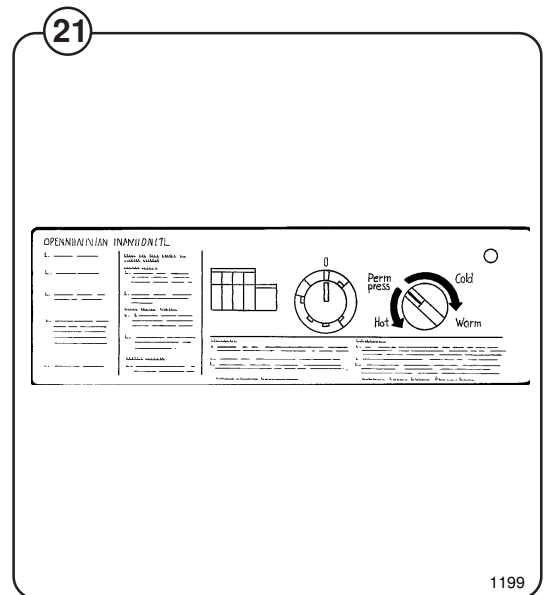

Wash Programs

Fig. In the figure below is an overview of the four wash programs.

24 On the following pages you will find a more detailed description of the programs.

24

	HOT			WARM			COLD			DELICATE		
	Time (Min.)	Temp.	Water Level	Time (Min.)	Temp.	Water Level	Time (Min.)	Temp.	Water Level	Time (Min.)	Temp.	Water Level
Prewash	3	Warm	High	3	Warm	High	3	Cold	High	3	Warm	High
Detergent 1												
Drain	1			1			1			1		
Mainwash	6	Hot	High	6	Warm	High	6	Cold	High	6	Warm	High
Detergent 2												
Drain	1			1			1			1		
Rinse 1	1	Cold	High	1	Cold	High	1	Cold	High	1	Cold	High
Drain	1			1			1			1		
Extract	0.5			0.5			0.5			0.5		
Rinse 2	1	Cold	High	1	Cold	High	1	Cold	High	1	Cold	High
Drain	1			1			1			1		
Extract	0.5			0.5			0.5			0.5		
Rinse 3	2	Cold	High	2	Cold	High	2	Cold	High	2	Cold	High
Detergent 3												
Drain	1			1			1			1		
Extract	4			4			4			1		
Shake-out	1.5			1.5			1.5			1.5		
Total time (water fill time not included)		24.5			24.5			24.5			21.5	

Wash program, Hot

Fig. 25

After the machine has started and the door automatically locked, the drain valve will close and the hot and cold water valves will open to fill the machine with mixed hot and cold water to the level determined by the level control.

When this level is reached, both water valves will close. During filling and then through the wash program the drum has a reversing rotation.

At the end of the pre-wash, the drain valve will open, whereafter hot water will fill to the level determined by the level control. At the same time detergent from compartment 2 is mixed with the incoming hot water.

The water level controlled machine will now wash the fabrics for 6 minutes. The machine is then emptied.

Cold water is filled to the high level for the first rinse which lasts one minute, followed by spin extraction for 30 seconds. After the extraction comes the second rinse in cold water, ending with spin extraction, whereafter the third rinse is started. Fabric softener is automatically admitted during the third rinse. The fabrics are rinsed in cold water for two minutes followed by a spin extraction of four minutes duration. Finally there is a shake out for one and a half minutes.

25

	HOT		
	Time (Min.)	Temp.	Water Level
Prewash	3	Warm	High
Detergent 1			
Drain	1		
Mainwash	6	Hot	High
Detergent 2			
Drain	1		
Rinse 1	1	Cold	High
Drain	1		
Extract	0.5		
Rinse 2	1	Cold	High
Drain	1		
Extract	0.5		
Rinse 3	2	Cold	High
Detergent 3			
Drain	1		
Extract	4		
Shake-out	1.5		
Total time (water fill time not included)		24.5	

Wash Program, Warm

Fig. 26 On starting the machine, the door will automatically be locked, and the pre-wash carried out as previously described, whereafter the main wash is started.

As the main wash is started, the drain valve closes, detergent is admitted and mixed hot and cold water is filled to the level determined by the level control.

On reaching this level, the water valves are closed.

The water level controlled machine will now wash the fabrics for six minutes. The machine is then emptied.

Cold water is filled for the first rinse which lasts one minute, followed by spin extraction for 30 seconds.

After this extraction comes the second rinse in cold water ending with spin extraction, whereafter the third rinse is started. Fabric softener is automatically admitted during the third rinse. The fabrics are rinsed with cold water for two minutes followed by a spin extraction of four minutes duration. Finally there is a shake out for one and a half minutes.

26

	WARM		
	Time (Min.)	Temp.	Water Level
Prewash	3	Warm	High
Detergent 1			
Drain	1		
Mainwash	6	Warm	High
Detergent 2			
Drain	1		
Rinse 1	1	Cold	High
Drain	1		
Extract	0.5		
Rinse 2	1	Cold	High
Drain	1		
Extract	0.5		
Rinse 3	2	Cold	High
Detergent 3			
Drain	1		
Extract	4		
Shake-out	1.5		
Total time (water fill time not included)		24.5	

Wash Program, Cold

Fig. 27 On starting the machine, the door will automatically be locked, the drain valve closed, the cold water valve opened and the pre-wash carried out as previously described, whereafter the main wash is started.

As the main wash is started, the drain valve closes, detergent is admitted and cold water is filled to the level determined by the level control.

On reaching this level, cold water is closed.

The water level controlled machine will now wash the fabrics for six minutes. The machine is then emptied.

Cold water is filled for the first rinse which lasts one minute, followed by spin extraction for 30 seconds.

After this extraction comes the second rinse in cold water concluded with spin extraction, whereafter the third rinse is started.

Fabric softener is automatically admitted during the third rinse. The fabrics are rinsed with cold water for two minutes followed by a spin extraction of four minutes duration. Finally there is a shake out for one and a half minutes.

27

	COLD		
	Time (Min.)	Temp.	Water Level
Prewash	3	Cold	High
Detergent 1			
Drain	1		
Mainwash	6	Cold	High
Detergent 2			
Drain	1		
Rinse 1	1	Cold	High
Drain	1		
Extract	0.5		
Rinse 2	1	Cold	High
Drain	1		
Extract	0.5		
Rinse 3	2	Cold	High
Detergent 3			
Drain	1		
Extract	4		
Shake-out	1.5		
Total time (water fill time not included)		24.5	

Wash Program, Delicate

Fig. 28 On starting the machine, the door will automatically be locked, the drain valve closed, the hot and cold water valves opened and the pre-wash will be carried out as previously described, whereafter the main wash is started.

As the main wash is started, the drain valve closes, detergent is admitted and mixed hot and cold water is filled to the level determined by the level control.

On reaching this level, the water valves are closed and the wash motor starts its reversing rotation.

The water level controlled machine will now wash the fabrics for six minutes. The machine is then emptied.

Cold water is filled for the first rinse which lasts one minute, followed by spin extraction for 30 seconds.

Fabric softener is automatically admitted during the third rinse. The fabrics are rinsed with cold water for two minutes followed by a spin extraction of one minutes duration. Finally there is a shake out for one and a half minutes.

28

	DELICATE		
	Time (Min.)	Temp.	Water Level
Prewash	3	Warm	High
Detergent 1			
Drain	1		
Mainwash	6	Warm	High
Detergent 2			
Drain	1		
Rinse 1	1	Cold	High
Drain	1		
Extract	0.5		
Rinse 2	1	Cold	High
Drain	1		
Extract	0.5		
Rinse 3	2	Cold	High
Detergent 3			
Drain	1		
Extract	1		
Shake-out	1.5		
Total time (water fill time not included)		21.5	

To change the wash programs

Fig. 29 You can change the following parameters in the wash programs by adding jumper wires to the terminal block at the rear of the machine.

- no prewash
- only two rinses

Fig. 29 **Water level during prewash/mainwash**
With jumper A (see figure) in place the machine fills water to the high level during prewash, mainwash and rinses.

If you remove jumper A the machine fills water to the low level during pre- and mainwash and to the high level during rinses.

Contact your local dealer for detailed information.

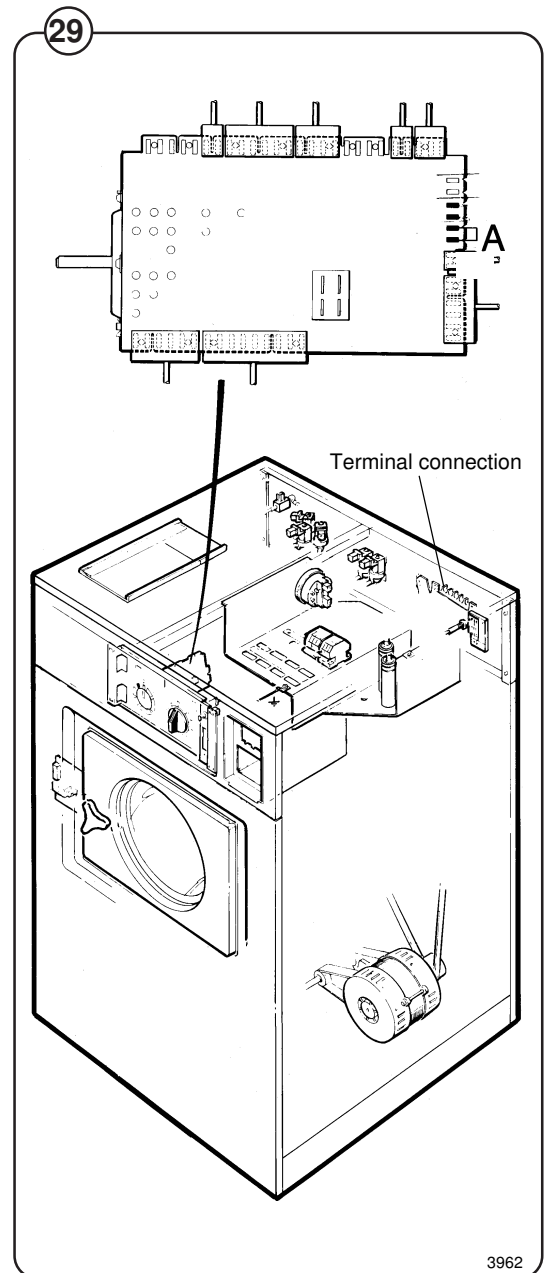

General

The door, cycle indicator, coin meter or manual start switches, indicator light and program-selection knob are located at the front of the machine.

All control and indicating components, i.e. relays, level control, cycle timer, etc are assembled under the top cover, easily accessible at the top of the machine for simplified servicing.

Main units

- Fig. 30
- 1 Program-selector - rotary switch for choice of different wash programs.
 - 2 Door - with automatic locking device which remains locked until the cycle is completed and the drum has stopped rotating.
 - 3 Detergent supply box - three compartments for automatic injection of powdered detergents and fabric softener.
 - 4 Inner cylinder - of stainless steel supported at the rear by two ballraces.
 - 5 Outer drum - of stainless steel (18/8) securely attached to the frame.
 - 6 Wash and extract motor - for reversing wash action and high speed extraction.
 - 7 Hot and cold water valves - program and level controlled solenoid valves for filling with water, and for flushdown of automatic detergent dispenser.
 - 8 Drain valve - timer controlled for draining the machine of water.
 - 9 Siphon breaker - to prevent water in the machine from re-entering the water supply system.
 - 10 Control unit - plug-in type for time and temperature control of the different wash cycles.
 11. Coin-meter or manual start switches.

Machine construction

Outer shell

Fig. 30 The outer shell is made of heavy gauge surgical steel and is attached to a heavy duty, rigid head casting (back gable).

The whole assembly is mounted on a heavy gauge fabricated steel base, galvanized for long life and corrosion resistance.

Panels

The machines are equipped with a top panel made of stainless steel. The front panel is available in different colors or in stainless steel. The colored panels are made of phosphatized steel plate. For servicing purposes, the panels can easily be removed.

Inner cylinder

The inner cylinder is made of perforated surgical stainless steel. It is equipped with three lifting ribs and has highly-polished side sheets and back with maximum embossed perforated area to assure high flow of water and supplies through fabrics.

Scientifically correct ratio of cylinder diameter and depth assures maximum washing action.

The shaft is electrically welded to the reinforced back of the cylinder. A specially designed chrome-plated sleeve bushing protects the seals from wear.

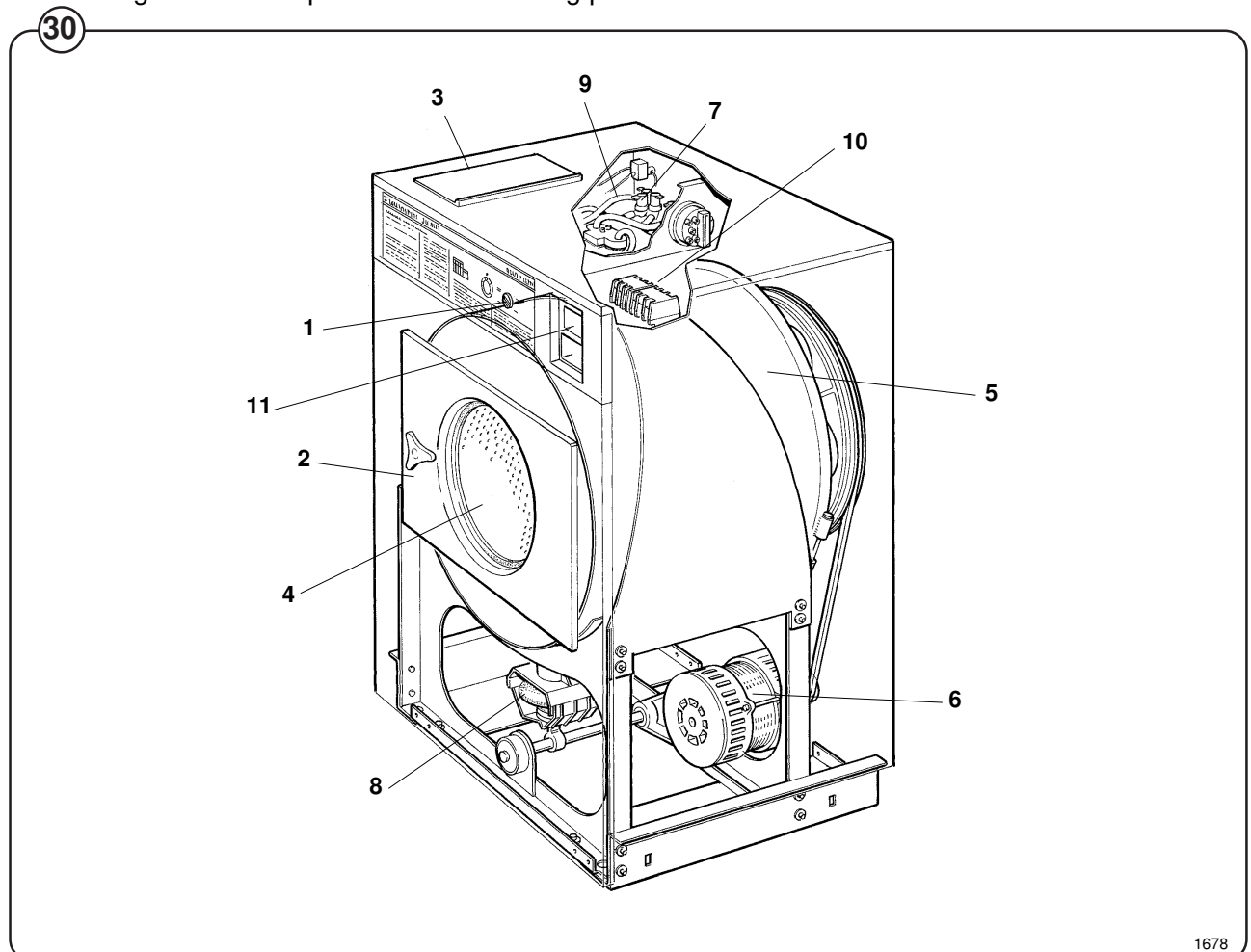

Panels

The machines are equipped with a top panel made of stainless steel. The front panel is available in different colours or in stainless steel. The colored panels are made of phosphatized steel plate with electrostatically applied baked enamel paint finish for rust and chip resistance. For servicing purposes, the panels can easily be removed.

Back gable and bearing

Fig. 31 The back gable and the bearing trunnion housing are constructed of a webbed heavy casting for extra rigidity. The bearings are protected against infiltration of water by three neoprene seals. An intermediate safety outlet provides an escape for any possible condensation.

The seals are mounted on a stainless steel, noncorrosive, specially hardened sleeve bushing that is mounted on the drive shaft to prevent wear of the seals and shaft. The main bearing is fitted machine-tight into the bearing trunnion housing. A nut is tightened on the shaft to prevent the cylinder from moving in and out.

The extension of the bearing trunnion housing supports the rear bearing holding the shaft. A grease seal is mounted to prevent escape of grease. The bearings are permanently lubricated and need no maintenance. Wascomat's design transfers the weight of the loaded wash cylinder to the largest possible surface area away from the bearings, for longest machine life.

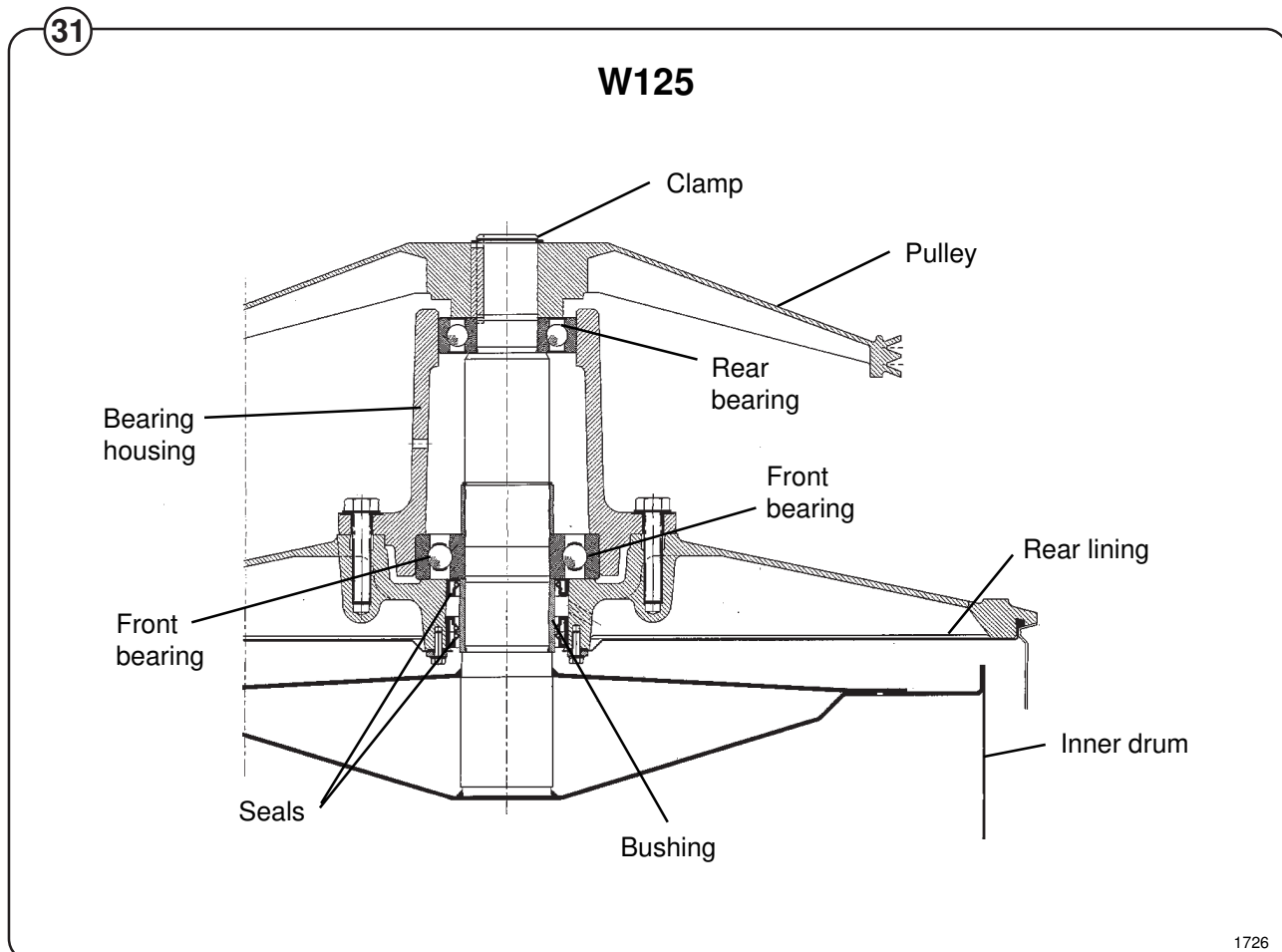

Door

Fig. 32 The door consists of: a door skirt (1), door (2), glass (3) and gasket (4). The frame skirt and door frame are both made of enameled aluminium. The skirt is bolted directly to the outer shell of the washing machine. The door hinges are fastened on the outside of the skirt and the door lock (5) is attached to the inside. The heat-hardened glass is mounted in the door using a special rubber seal which also acts as a gasket between the door and the washing machine's outer shell when the door is closed.

Door lock

Fig. 33 The door lock consists of a circuit board (1) with a connector. Mounted on the board are the lock plate (2), against which the locking bolt turns to lock the door, and a microswitch (3) which closes when the locking bolt has locked the door.

There is also a locking device on the circuit board which acts to lock the locking bolt in place when the machine starts up.

The locking device consists of a double-acting solenoid (4), a delay unit (5) and the locking device itself (6) which operates sideways in blocking the locking bolt with a stud. The locking device can be affected by both the solenoid and the delay unit.

The lock operates as follows:

- When the door is shut and the locking bolt moved to the lock position, the micro switch will indicate that the door is closed.
- When the machine is started, the solenoid actuates the locking device, blocking the door lock. The locking device signals the delay unit, closing a switch in the unit. The washing machine motor will start and water enter the machine only after the delay unit receives the information that the door is locked. The bi-metallic spring in the delay unit is warmed up at the beginning of the program.
- Once the washing machine stops at the end of a cycle, the solenoid pulls back the locking stud and allows the door to open. The delay unit is spring-mounted in the locking device and is also pulled back by the solenoid, which operates for about two minutes to allow the bi-metallic spring to cool down enough not to lock the door again.
- If current should disappear during a cycle, the delay unit will keep the door locked for about two minutes, ensuring that the wash water can drain out (The drain valve opens automatically when current is lost).

NOTE

Do not attempt to repair a faulty door lock. The individual components are not available. Always replace the old unit with a new one to assure proper operation of the door safety interlock.

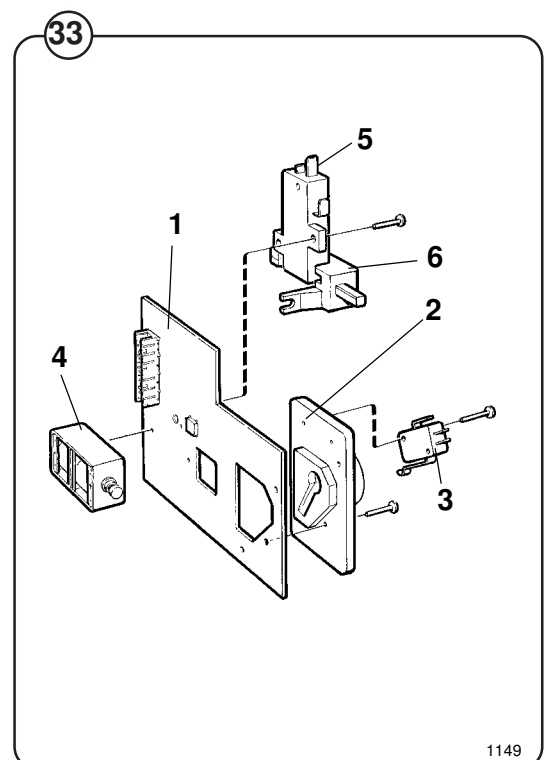
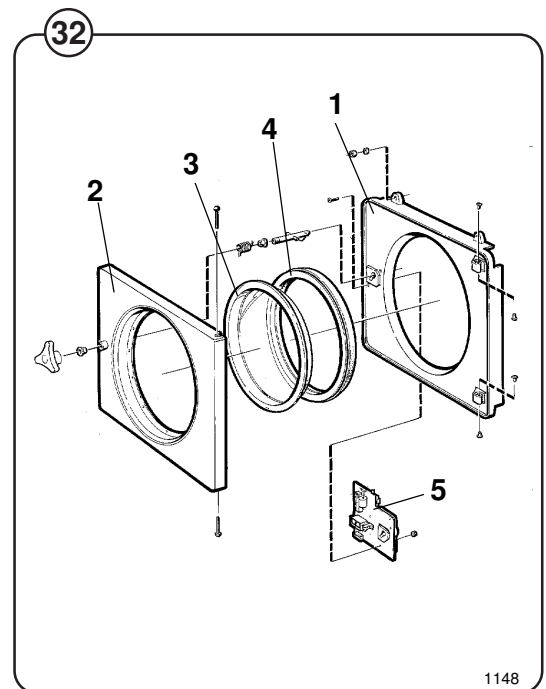

Control unit

Fig. 34 The wash cycle timer (1) and rotary program selector switch (2) are mounted just behind the control panel.

The relays (3) and level controls (4) are located at the top of the machine, easily accessible for service, as are the motor capacitors (5) on 1-phase models.

Electrical connections to the machine are made by quick-disconnect plugs.

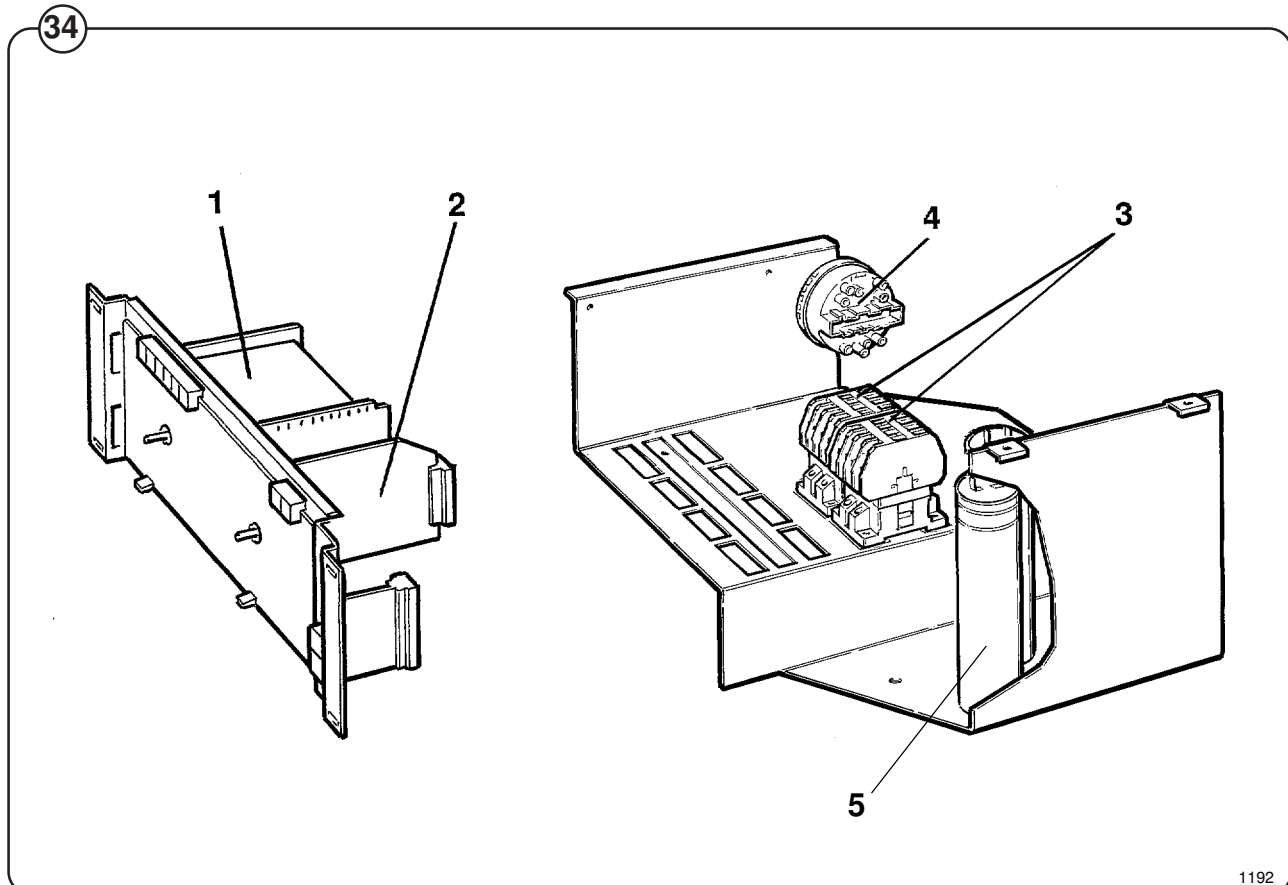

Relays

Fig. 35 The W-series models employ either two (W75, 105) or three (W125, 185) relays to energize the windings of the wash/extract motor.

The relays control:

- The reversing action of the motor at wash speed.
- The action of the motor at extraction speed.

Construction

Fig. 36 The body of the relay holding the stationary contacts is made of current-resistant plastic. A solenoid and a contact bank hold the moving contacts. The contacts are spring-loaded to assure the correct contact pressure.

The relay is constructed for continuous operation, whether mounted horizontally or vertically.

Screw-type terminals provide perfect connections even when one or two wires have different diameters.

Operation

When the solenoid is energized, the two halves of the magnet core are drawn together, pulling down the moving contacts, thus making or breaking the circuit. When the current cuts out, springs force the contact bank into its original position, thus closing or opening the circuits.

Trouble shooting

If the relay fails to operate despite power to the coil, turn off the power and check the solenoid by measuring the resistance across the terminals (1).

If the relay hums when power is applied, this indicates either a break in the insulator holding the moving contacts at the axle where it holds the top half of core (3), or a rusty core (4), which can be cleaned.

Make sure that the moving contact assembly moves freely. Always replace burnt or pitted contacts (2) ... do not reuse contacts.

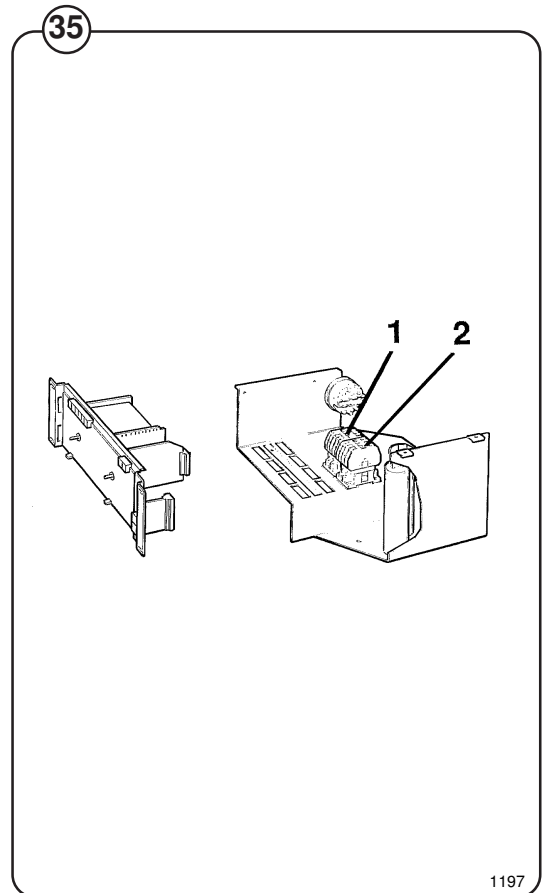

1197

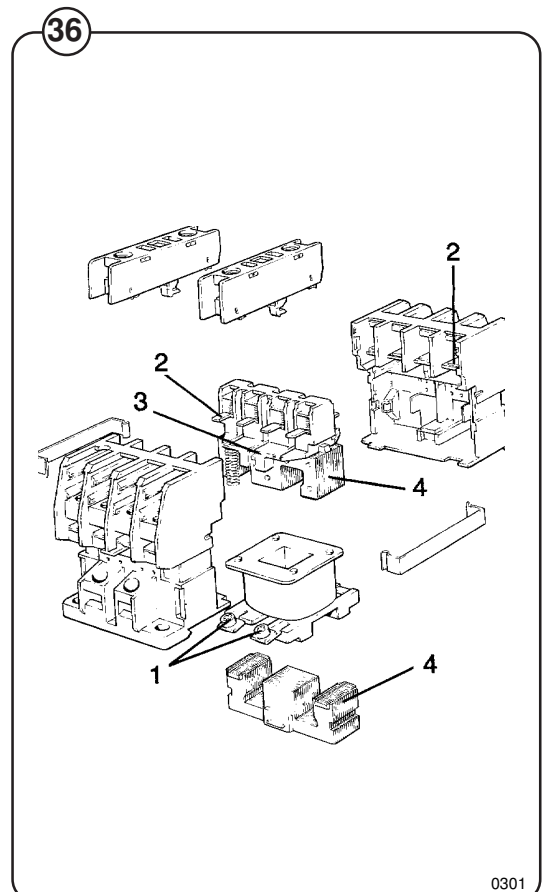

0301

Water level controls

Fig. 37 One pressure switch is used to control the correct water levels during various cycles of the washing program.

Adjustment

All pressure switches are factory-calibrated to meet specific requirements. The trip level for any one pressure switch can be changed only within narrow limits because each trip range requires a different set of springs. Call Wascomat's Service Department at 516-371-0700 before attempting to adjust the level control.

Water level

As a guide for checking the level control for proper functioning, the normal level should be approximately at the bottom of the door glass. It is primarily the reverse-wash mechanical action of the washer which gets clothes clean, not the level of water or amount of detergent. The water levels are set at the factory to get a full load clean without wasting a drop of water, to save you money and protect the environment.

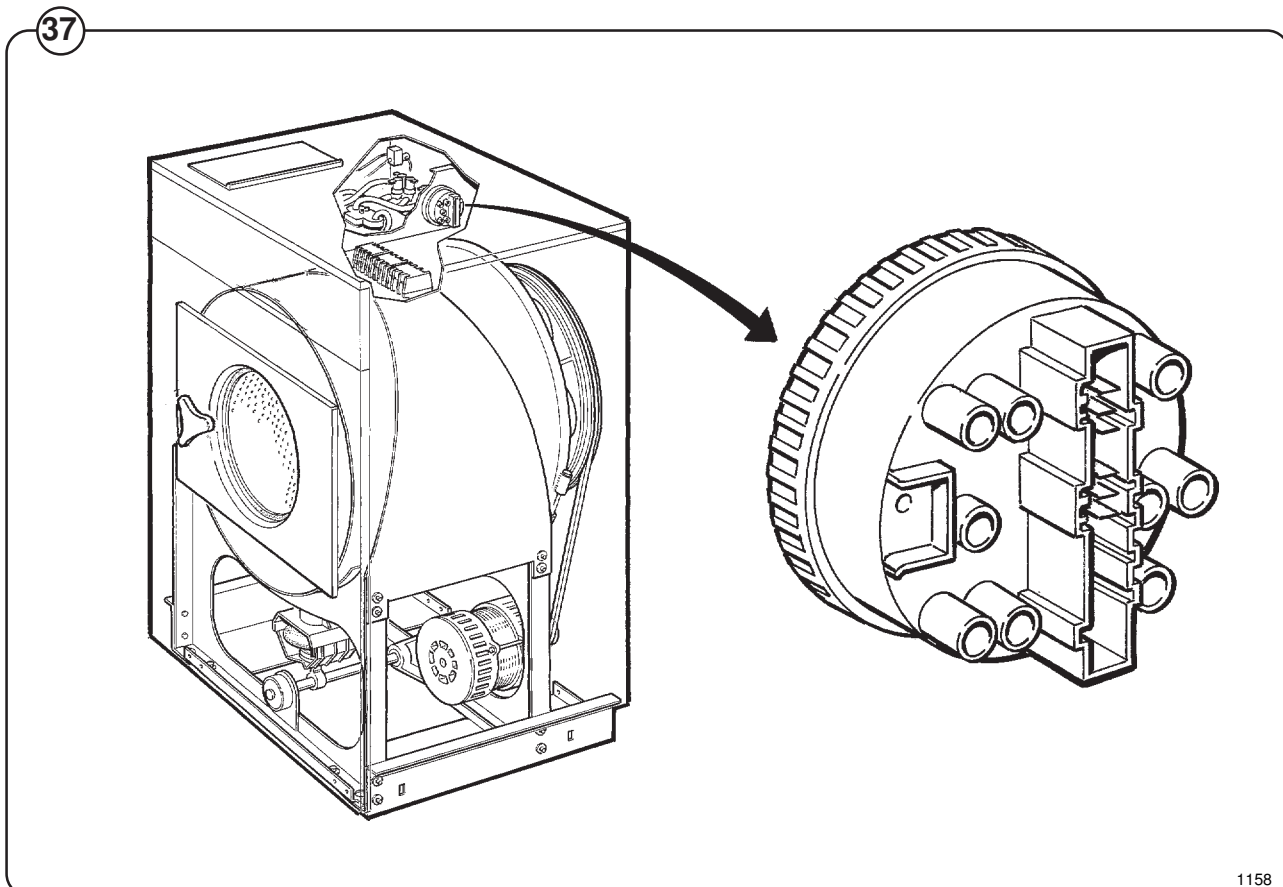

Drive motor

Description in general

Fig. 38 The motor is mounted on an axle with rubber dampeners.

Fig. 39 The V-belt is tightened by turning the motor on the axle and locking it in place using the tensioner on the rear side of the motor. The motor and tensioner have vibration and noise dampening rubber suspensions.

Construction in general

The motor consists of stator, rotor and end-shields with ball-bearings. The stator and the rotor consist of plates, insulated from each other and welded together. The stator is provided with slots in which the 2-pole and 18-pole windings are wound. The windings are impregnated with a temperature-resistant sound-insulating resin varnish according to class B. The end-shields are die-cast. The ball bearings are permanently lubricated.

Construction of single-phase motor

Single-phase motors have an 18-pole winding (wash-speed) the same as three-phase motors, using a continuously connected capacitor, while the 2-pole winding (extract-speed) is a specially designed winding with both a continuously connected capacitor and a starting capacitor.

Function of 3-phase motor

When the stator winding is charged, a magnetic field will occur, which in turn will rotate the rotor at a fixed RPM depending upon the number of poles in the winding. The 18-pole winding gives the wash speed and the 2-pole winding the extract-speed. When operating with load, the speed deviates slightly from the synchronous (no-load) speed. This difference is called the slip and is usually expressed as a percentage of the synchronous speed. The motors will work satisfactorily at nominal voltage +10%-15%.

Function of single-phase motor

When the stator winding is charged without a capacitor, two counteracting magnetic fields are created. When a capacitor is connected, it will displace one of the two magnetic fields adding it to the other, creating a torque turning the rotor in a specific direction. The RPM is the same as for the 3-phase motor.

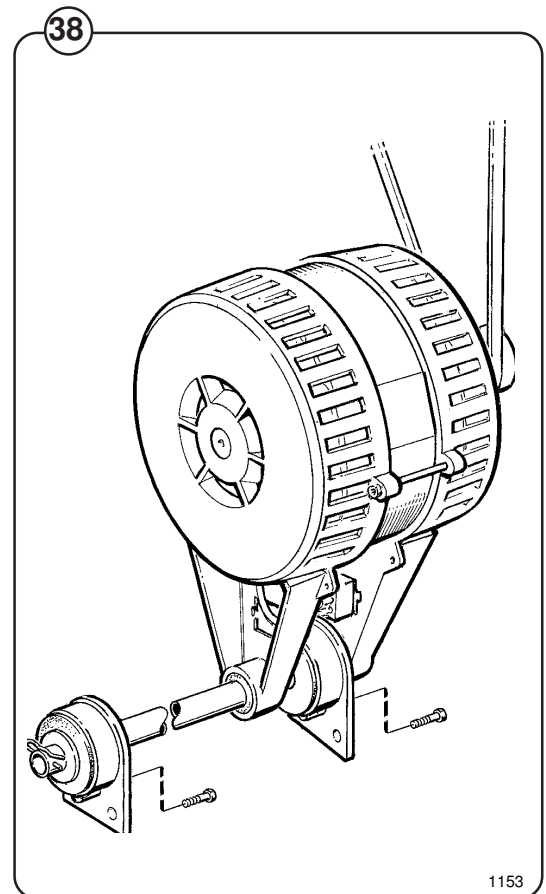

1153

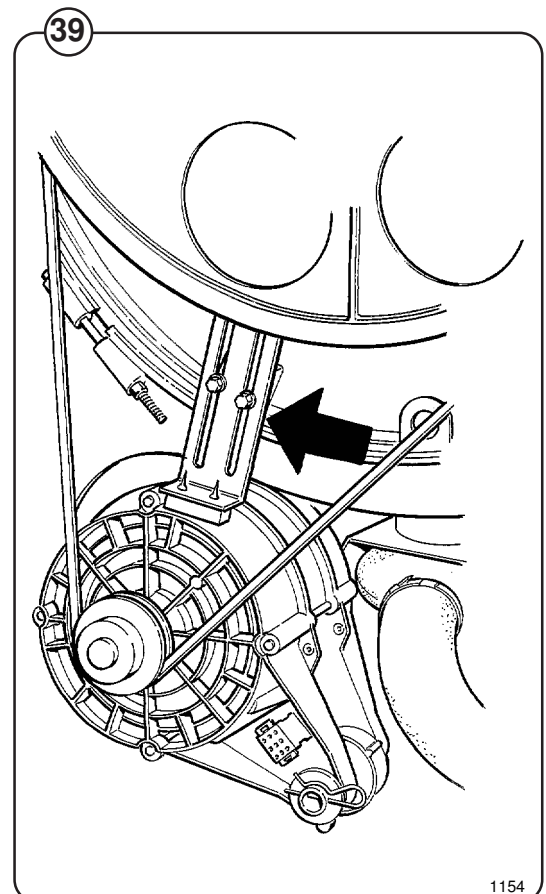

1154

Principal wiring and points of measuring on single-phase motors.

Fig. The numbers at the connection points refer to the terminal numbers at the motor connector plug.

40

The numbers in circles indicate points of ampere measurements.

40

W75 120 V 60 Hz single-phase

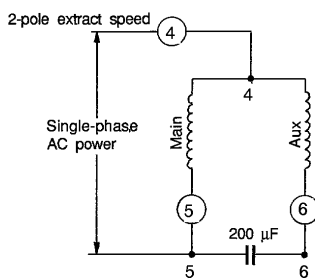

EXTRACT WINDINGS

Measuring point	at full speed
④	10 A
⑤	7 A
⑥	14 A

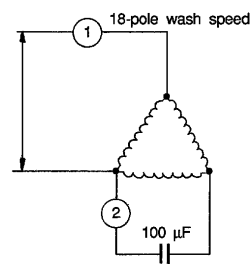

WASH WINDINGS

Measuring point	unloaded
①	4 A
②	4.9 A

W105 120 V 60 Hz single-phase

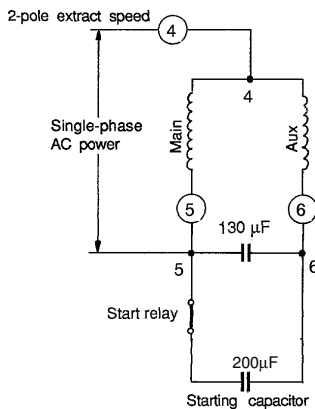

EXTRACT WINDINGS

Measuring point	at full speed
④	5.5 A
⑤	2.0 A
⑥	6.5 A

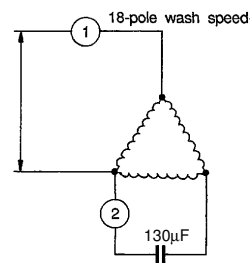

WASH WINDINGS

Measuring point	unloaded
①	3.5 A
②	5.0 A

40

W125 208-240 V 60 Hz single-phase

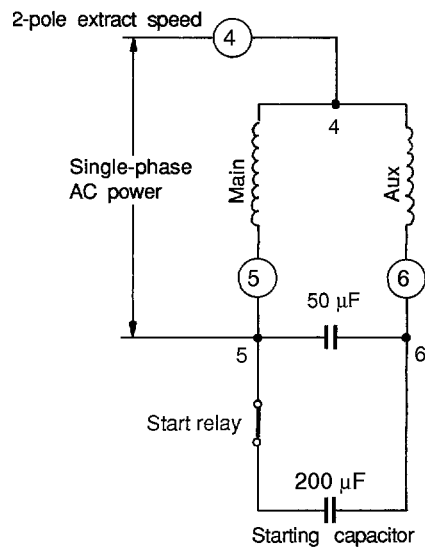

EXTRACT WINDINGS

Measuring point	att full speed	
	208 V	240 V
④	3 A	4 A
⑤	3 A	6 A
⑥	6 A	7 A

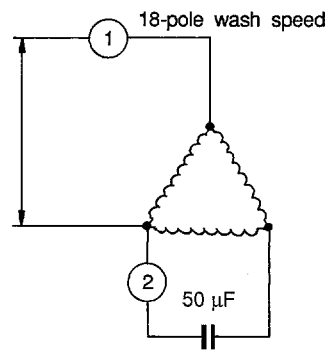

WASH WINDINGS

Measuring point	unloaded	
	208 V	240 V
①	2.9 A	3.9 A
②	4.6 A	4.8 A

40

W185 208-240 V 60 Hz single-phase

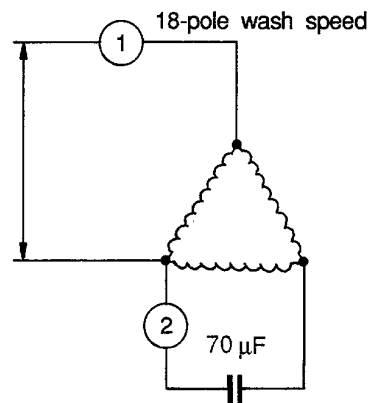
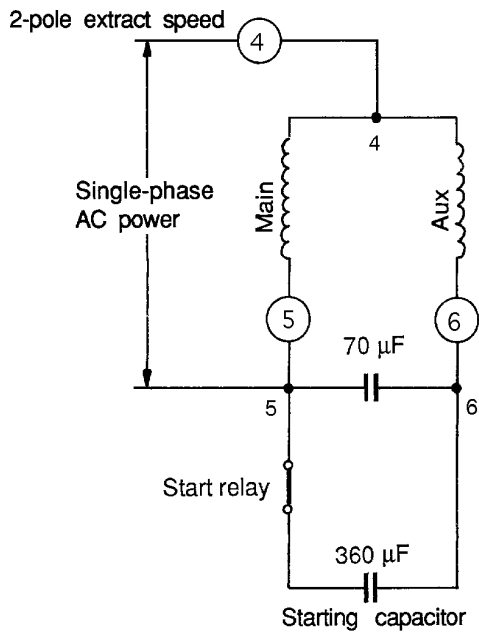

EXTRACT WINDINGS

Measuring point	att full speed	
	208 V	240 V
①	5 A	8 A
②	5 A	12 A
③	7 A	9 A

WASH WINDINGS

Measuring point	unloaded	
	208 V	240 V
①	3,3 A	4,2 A
②	6,8 A	7,2 A

Motor connections

- Fig. 1, 2 and 3: wash speed (18-pole winding).
 (41) 4, 5 and 6: extract speed (2-pole winding)
 7 and 9: motor overload protector.

Motor overload protector

The motor is equipped with two self-resetting, thermal overload protectors, situated one in each of the windings of the stator. The protectors are connected in series and will trip at a temperature of 120°C (248°F) (3-phase) or 130°C (266°F) (single phase). In the event the protectors fail but the motor remains otherwise undamaged, an overload protector may be mounted in the control unit of the machine. Before making such installation check to ascertain that the windings are not damaged. A burned out motor can be re-wound.

NOTE

Before connecting a separate overload protector consult the local code.

Single-phase W125 and W185 machines are also equipped with a manually resettable overload protector mounted on the extract relay in the control unit. This overload protector protects the motor during the start-up of the extraction.

Removing the motor

- Fig. (42)
- Remove the drain valve (1) from the long shaft by pulling it straight up.
 - Remove the tensioning unit (2) on the rear of the motor.
 - Disconnect the connector (3) placed diagonally under the rear edge of the motor.
 - Remove the two screws (4). Pull the shaft forward slightly until the guide pins pull out of the shaft brackets. Remove the motor unit.

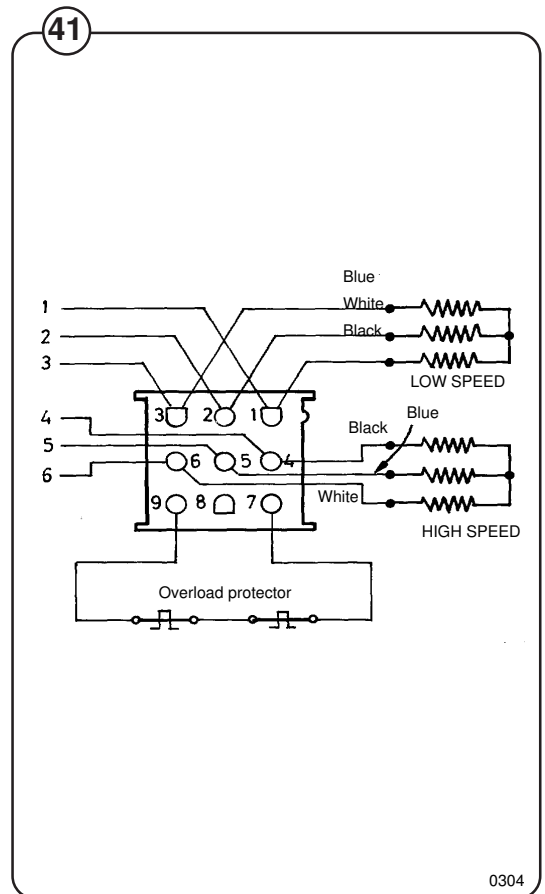

0304

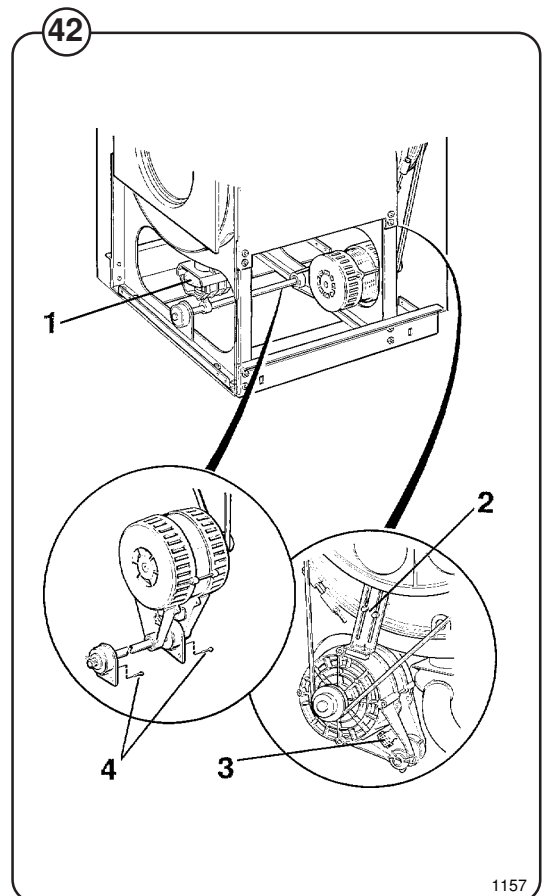

1157

Inlet valves for W75, W105, W125 and detergent valve for W185

Construction

Fig. 43 Each valve has a single-inlet with either one, two or three outlets, each with its own solenoid coil. The body is made of heat-resistant polyamid plastic and the solenoids encased in water-tight plastic.

A filter screen on the inlet side prevents dirt from entering the valve. Flow restrictors can be placed at either the inlet or any of the outlets.

Operation

Fig. 44 When the solenoid is energized, the spring-loaded plunger is drawn up and the pilot valve in the center of the diaphragm opens. Because of the difference in diameter between the pilot valve opening and the ventilating hole in the diaphragm, the pressure above the diaphragm drops to a point where the admission pressure below the diaphragm can lift the diaphragm, thus opening the valve.

When the current to the solenoid is cut off, the plunger spring will press the plunger against the pilot opening of the diaphragm. The pressure above the diaphragm then rises to correspond to the water inlet pressure and the pressure of the spring will close the valve.

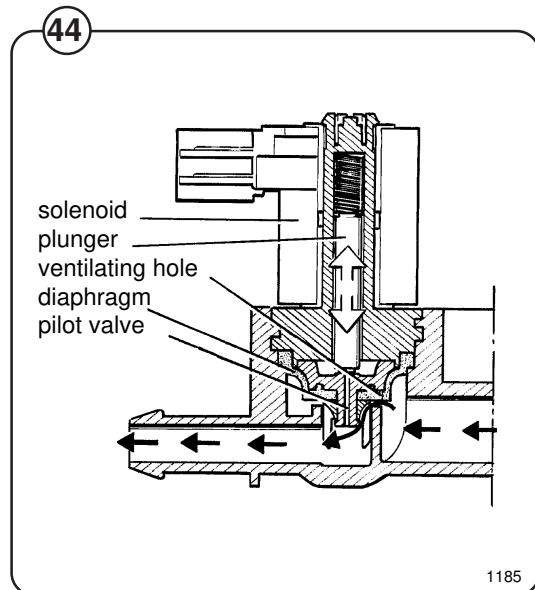
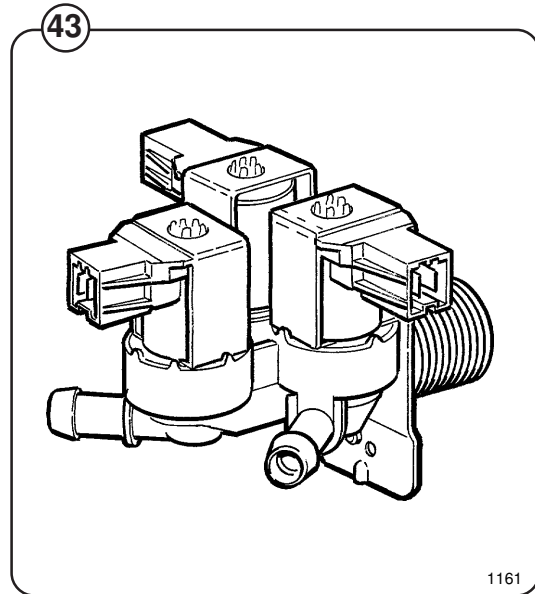

Maintenance instructions

Limescale can block the hole in the valve diaphragm and interfere with the function of the valve.

Fig. 45 It is therefore advisable to dismantle and clean the valve at certain regular intervals. The frequency depends on operating conditions and the level of contamination in the water.

Trouble shooting

If the valve does not open

- Check that power is supplied to the coil.
- Check the coil with an instrument to determine whether there is a break or a short circuit.
- Dismantle the valve (see below) and check the openings in the valve diaphragm.
- Check the inlet strainer and clean as required.
- Undo the coil and clean the surfaces of the magnetic core.

If the valve does not close

- Check that the coil is not live. The valve is normally closed when the magnet is not energised.
- Check the return spring.
- Check the diaphragm (pilot pressure opening).

Dismantling the valve

Fig. 46 • Pull the coil straight upwards. Use a screwdriver if necessary to carefully undo the coil.

Fig. 47 • Use the tool supplied with the machine (attached to one of the hoses when the machine is delivered) to open the valve housing. Slide the tool over the protruding plastic sleeve to that the pegs on the tool engage the corresponding sockets in the valve housing.

- Use a spanner or a pair of pliers and unscrew the upper part of the valve housing.

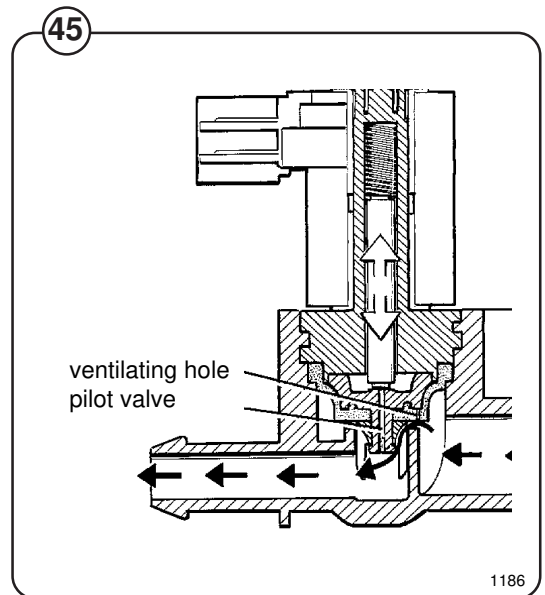

1186

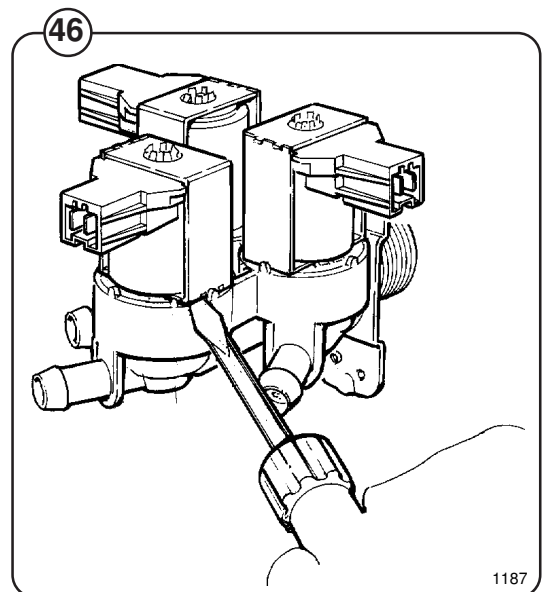

1187

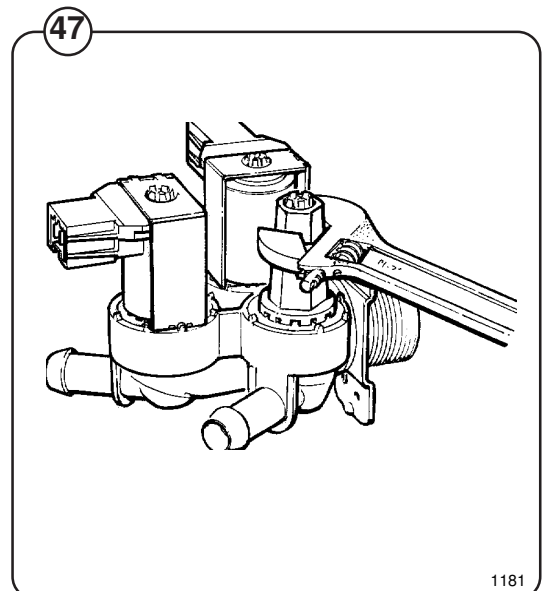

1181

Inlet valve for W185 from S/N 9508/011935

Fig. 48 The water inlets have brass bodies with larger cross section of the outlet in order to achieve a shorter filling time for the machine.

Construction

Fig. 49 The valve housing is made of pressed brass. The spring-loaded plunger is made of stainless steel and located at its lower end.

Operation

The valve is automatically operated by means of a rubber diaphragm and a pilot valve in exactly the same way as the supply injector valve.

NOTE: To strip, clean, re-assemble and troubleshoot the inlet valve, follow the instructions outlined for the supply injector valve.

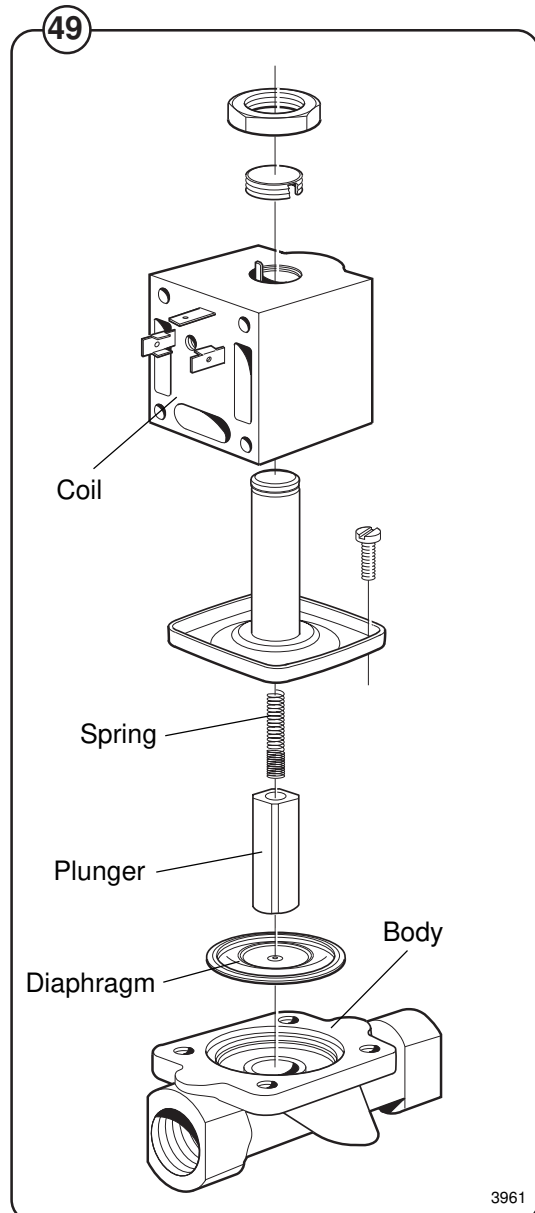
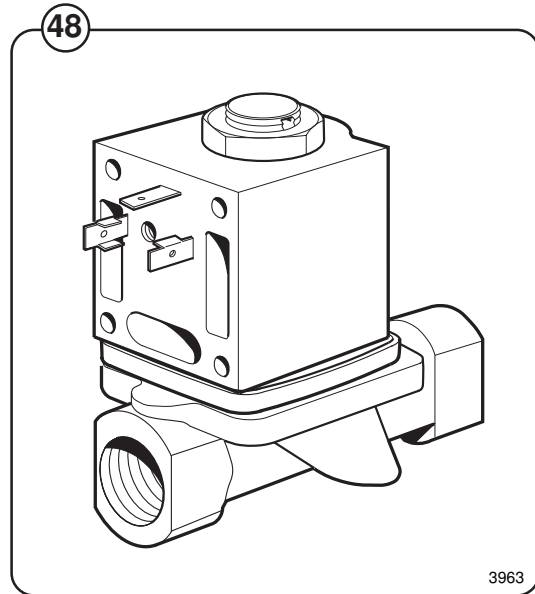

Inlet valve for W185 up to S/N 9508/011934

Fig. 50 The water inlets have brass bodies with larger cross section of the outlet in order to achieve a shorter filling time for the machine.

Construction

The valve housing is made of pressed brass. The spring-loaded plunger is made of stain-less steel and located at its lower end is a rubber gasket for the pilot valve.

Operation

The valve is automatically operated by means of a rubber diaphragm and a pilot valve in exactly the same way as the supply injector valve.

NOTE: To strip, clean, re-assemble and troubleshoot the inlet valve, follow the instructions outlined for the supply injector valve.

Clean out

At water temperatures of more than 60°C/140°F, the lime deposits are heavily increased. This can cause function problems due to blocking up the equalizing orifice of the valve.

Fig. 50 The fault can be eliminated by cleaning the equalizing orifice (marked A).

Fig. 51 If there are much deposits the orifice can be changed from 0.5 mm to 0.8 mm. The screwhead of the orifice is marked with 1 ring for the size of 0.5 mm and 2 rings for the size of 0.8 mm.

Clean the orifice as follows:

1. Shut off the main supply.
2. Unscrew the orifice.
3. Clean the hole in the orifice carefully with a pin or similar not thicker than 0.5 resp. 0.8 mm.
4. Mount the orifice, be careful with sealing and tighten.
5. Open the main supply.

Fig. 52

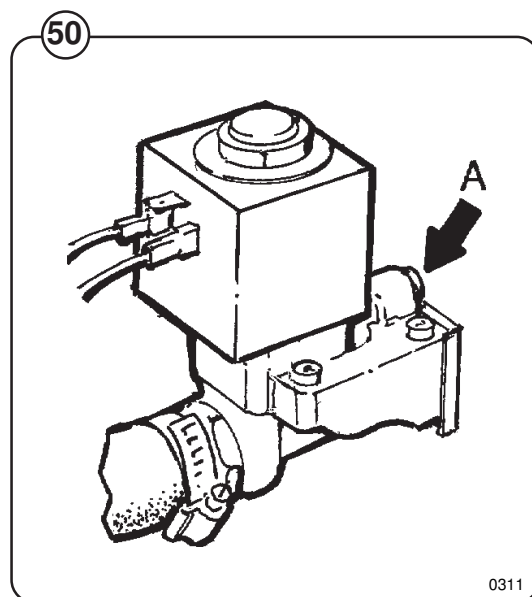

0311

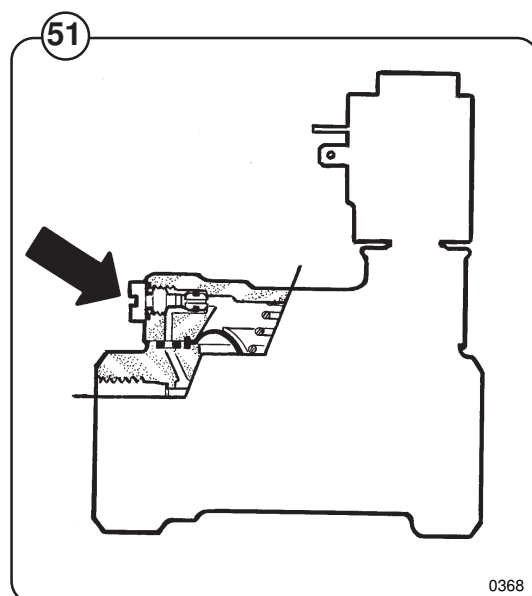

0368

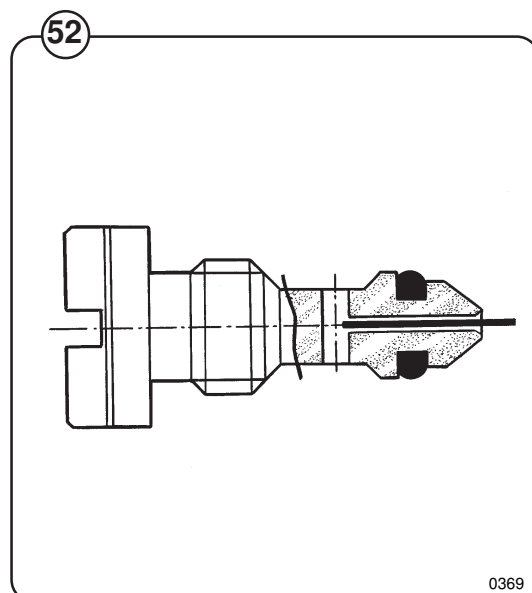

0369

Drain valve

Description

Fig. 53 The drain valve is operated by using the pressure in the cold water intake. A tube (1) is connected between the cold water intake and a solenoid valve (2). When the solenoid valve is activated, it opens and allows water to flow into the feeder tube (3). The water presses up a piston (4), which uses the pressure lid (5) to close the drain valve rubber membrane. When the solenoid valve cuts out, the water pressure push the piston back, allowing the water to pass the solenoid valve and drain out via the return tube (7).

Trouble shooting

If the drain valve doesn't close:

- Check that the solenoid valve (2) receives electricity.
- Check that the solenoid valve and the tubes are clear by:
 - removing the drain hose (3).
 - Check that water exits the hose when the valve is activated.
- Check that the diaphragm (8) is undamaged.

If the drain valve doesn't open:

- Check that the return tube (7) is open.
- Check that the piston (4) doesn't seize.

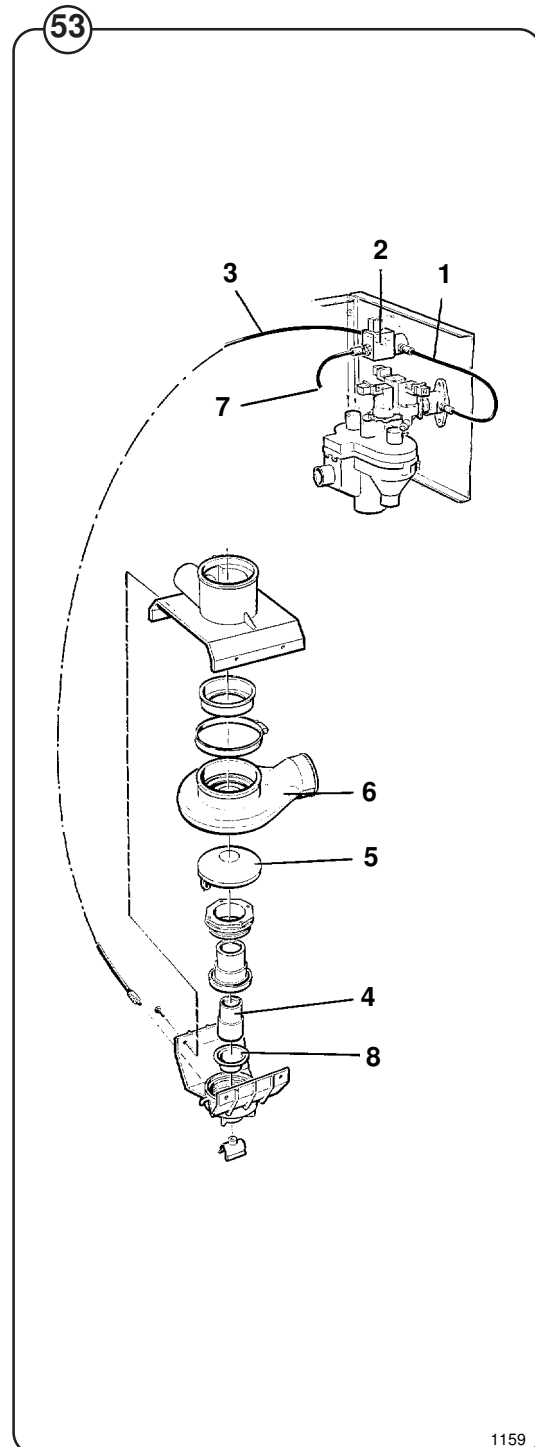

Soap supply box

Fig. 54 The three-compartment soap supply box is located at the top of the machine. Viewed from the front, the compartments are marked with figures 1, 2 and 3 and are used as follows:

Compartment 1

This compartment is used for adding powder detergent at the beginning of the Prewash cycle. Powders may be loaded immediately; for liquids, wait until the compartment flushes with water.

Compartment 2

This compartment is used for adding detergent at the beginning of the Wash cycle. If liquid bleach is used, it is added to this compartment when the compartment is flushed with water.

The insert is used to help prevent oversudsing.

Compartment 3

This compartment is used for liquid fabric softener, which is siphoned into the drum at the start of the third rinse. Liquid softener may be added at the beginning of the cycle or during the final rinse.

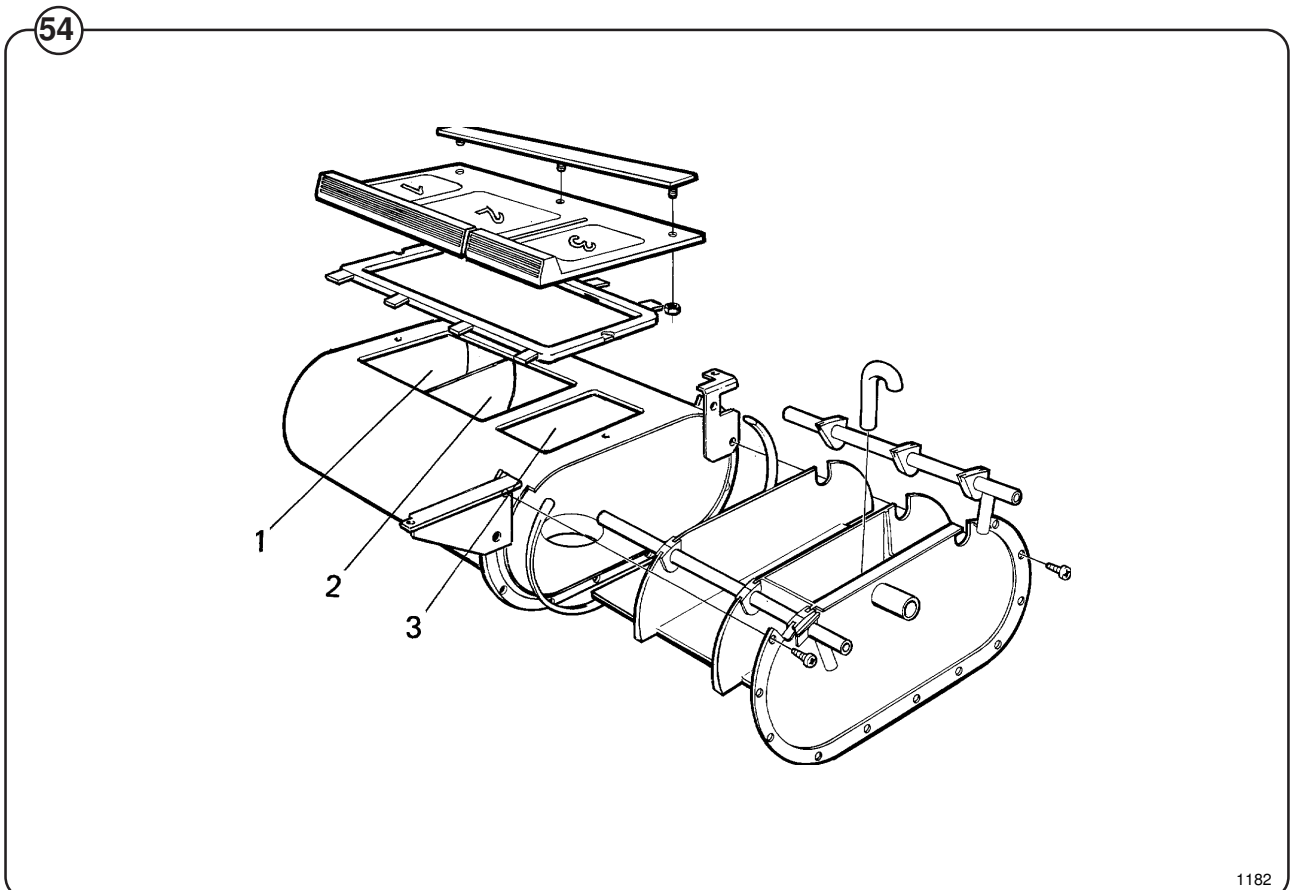

Maintenance

Preventive maintenance has been reduced to a minimum by the careful design of reliable components and material.

However, the following measures should be taken at regular intervals and in proportion to the hours of service.

IMPORTANT!

Make certain that all electrical power to the machine is shut off before removing top or rear panels.

Daily

- Check the door lock and interlock before starting operations.
- The soap supply box should be cleaned at the end of each working day as follows:
 - Use a spatula to scrape loose any detergent which may have stuck on the inside of the dispenser.
 - Flush the loosened detergent with warm water.
 - Wipe dry and leave lid open.
- Check that the drain valve does not leak and that it opens properly.
- Check that the door does not leak. Clean residual detergent and foreign matter from the door gasket.
- Wipe the outside of the machine.
- When the machine is not in use, leave door slightly open to allow moisture to evaporate.

Fig.

55

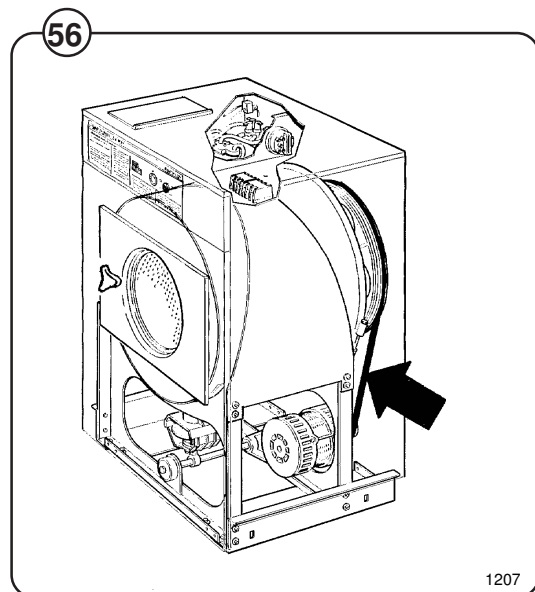
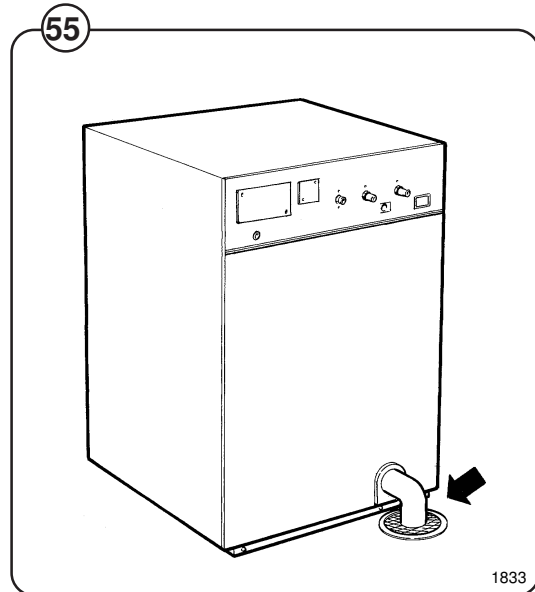

Weekly

- Remove the hose from the drain connection and clean the inside of the drain valve.

Every three months

Fig.

56

- Remove the rear panel of the machine and check that the V-belt of the wash motor is undamaged and correctly tensioned.
- Check that all tubing, piping and connections are free from leaks.
- Wipe and clean the inside of the machine, making sure that the control components are protected from moisture and dirt during the cleaning operation.

The purpose of the trouble-shooting guide is to facilitate the location and correction of the most common machine problems.

Before the top panel is removed, power to the machine must be switched off at the main source or at the separate circuit breaker.

At each trouble-shooting attempt, the plug in connectors on the control panel should be moved in and out in order to eliminate improper contact due to faulty connection.

Please note that this guide does not include all possibilities, but only those most likely to cause the symptoms listed.

In trouble-shooting electrical problems, always make certain to have the proper electrical schematic or wiring diagram at hand. Test for power using a V-O-M or similar meter on the AC voltage scale. Test for continuity with all electrical power off.

Trouble shooting

If the machine does not start

- Fig. 57
- A Check the circuit breaker in the electrical power line to the machine.
 - B Check the door safety switch and door lock.
 - C Check the glass cartridge fuses.
 - D Check for loose wires at the incoming power terminal block.

If water does not drain

- Fig. 58
- A Check the drain valve and drain solenoid for proper operation.
 - B Disconnect the drain hose connected to the drain line. If a full flow of water comes out, the problem is in the main waste line. If water flow is slow, the problem is the accumulation of foreign materials between the drain valve and shell outlet of machine. Clean the valve body of any foreign objects found.

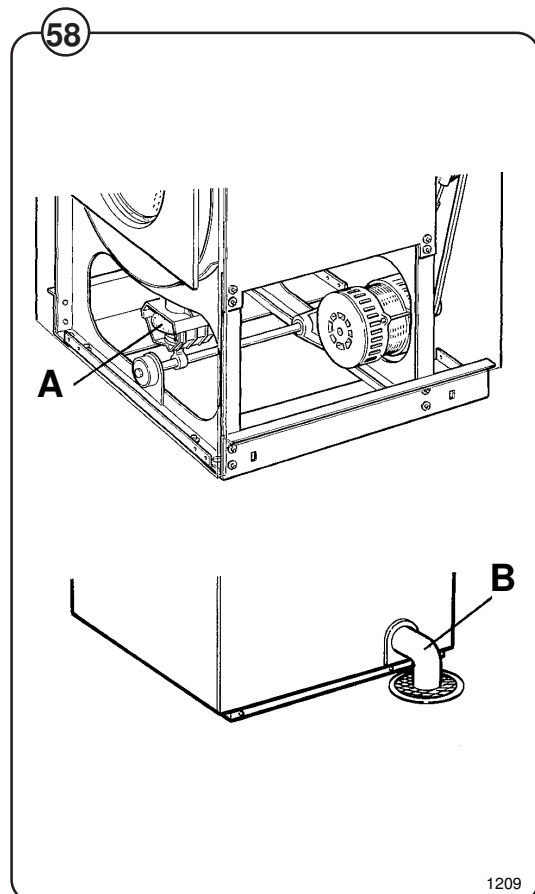
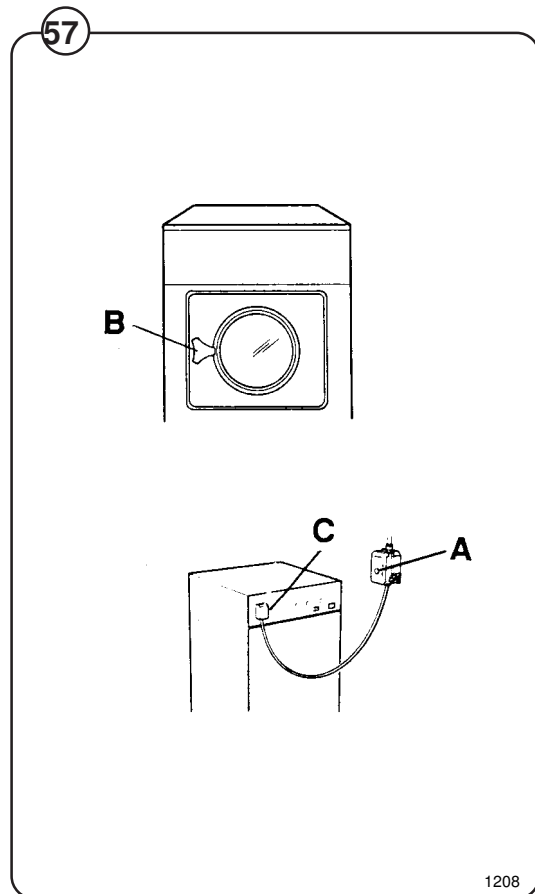

If the machine does not extract

- Fig. 59 A Check the extract relay and relay coil for proper operation.

If the motor does not operate at wash speed

- Fig. 60 A Check the wash relay(s).
B Check the normally-closed contact of the extract relay.
C Check the motor and V-belt.

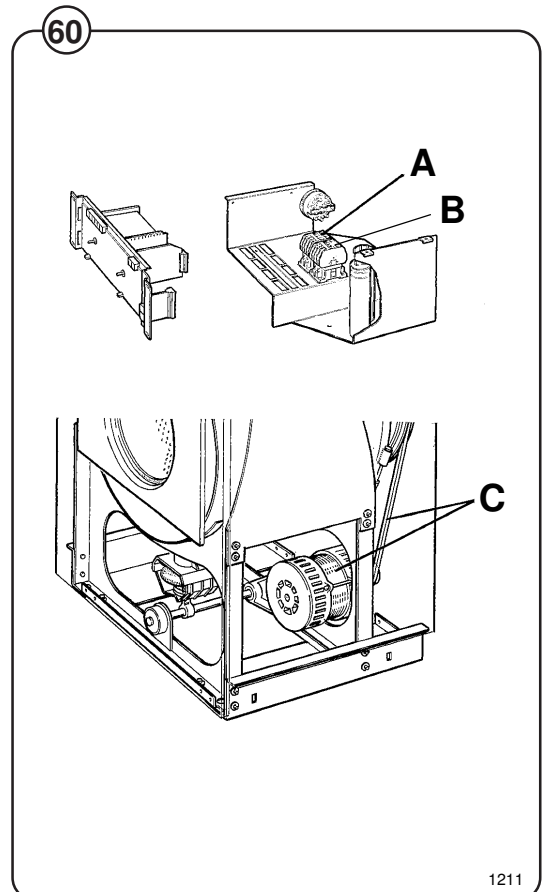
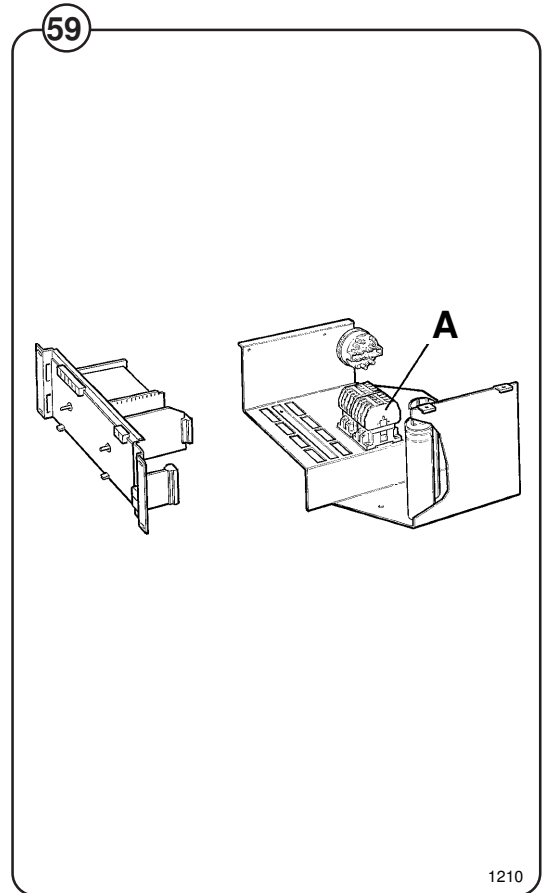

If the machine runs slowly on wash speed or there is a slapping or thumping noise.

Fig. 61 A Replace the V-belts

If a metallic noise can be heard at rear of machine

Fig. 62 A Tighten the pulley on the motor shaft

If the door is leaking

Fig. 63 A Check the door gasket. If the gasket is in good condition, install a 4-7 mm rubber hose seal around the entire gasket, using the slits provided.

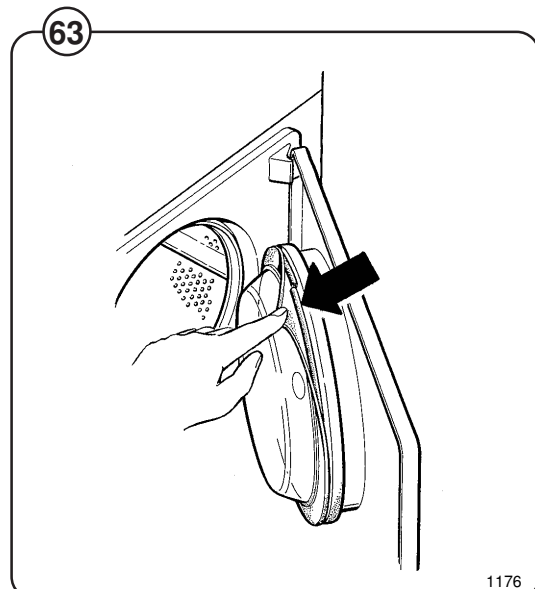
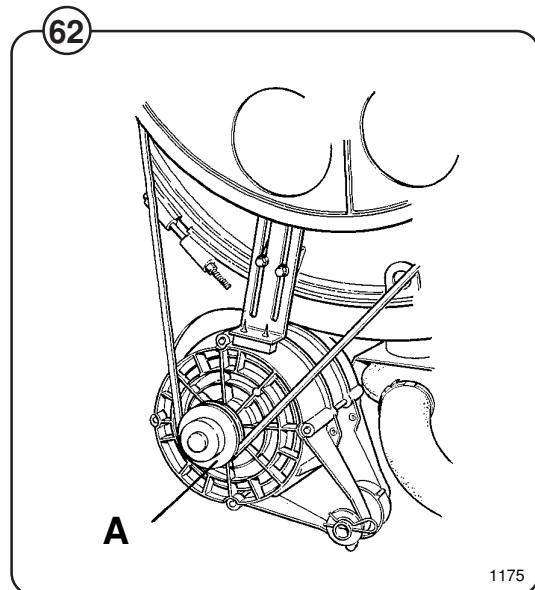
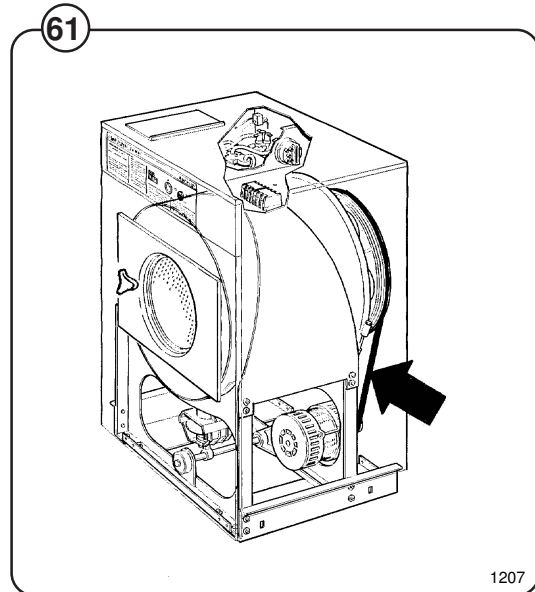

If there is a leaking around the glass

Fig.

- 64 A Replace the door gasket if worn.

If water does not enter the machine.

Fig.

- 65 A Check the valve coils on the inlet valves.
 B Check wires leading to the valve coils.
 C Be sure manual shut-off valves are in open position.

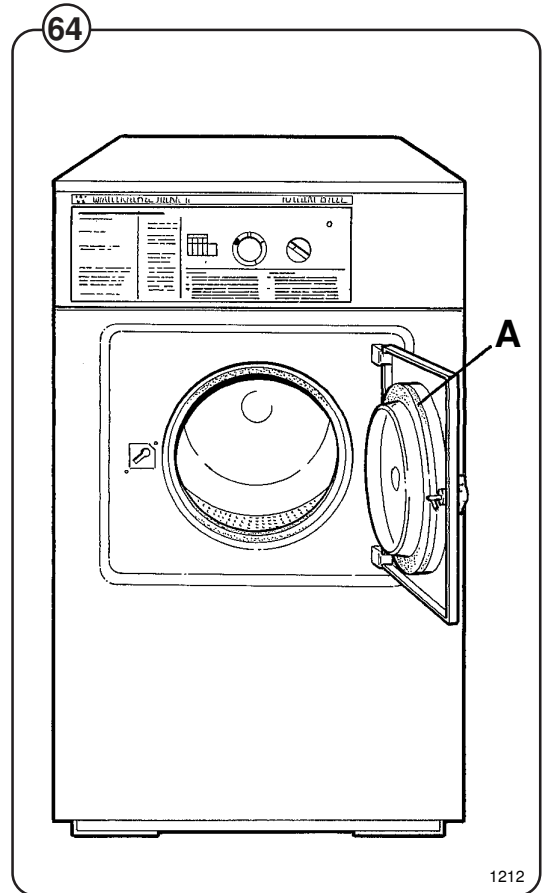

1212

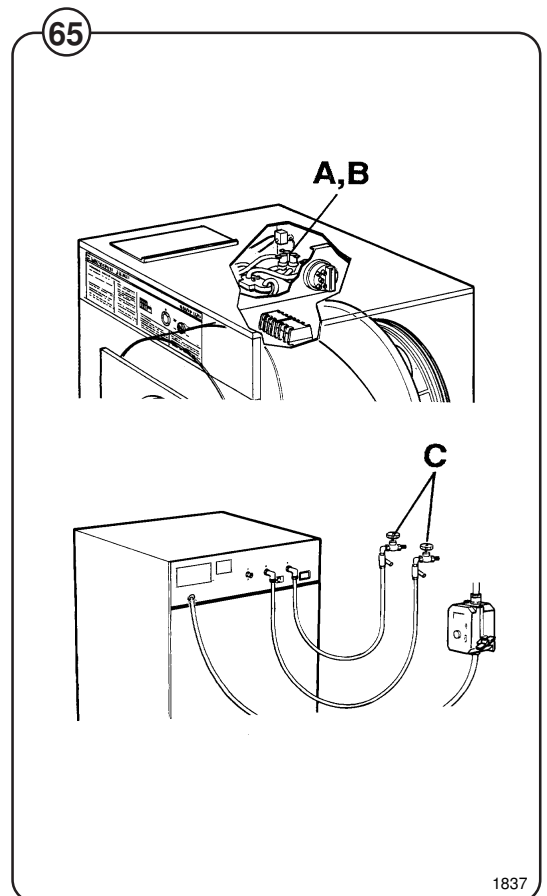

1837

If water continues to fill without stopping.

Fig. **66** A Check the hose attached to the level control unit.

B Check inlet valves for dirt underneath the valve diaphragm. To isolate the cause, shut off power. If water continues to flow, inlet valves have foreign material in them and should be thoroughly cleaned.

If water continues to flow without filling the machine.

Fig. **67** A Check seating of the drain valve.

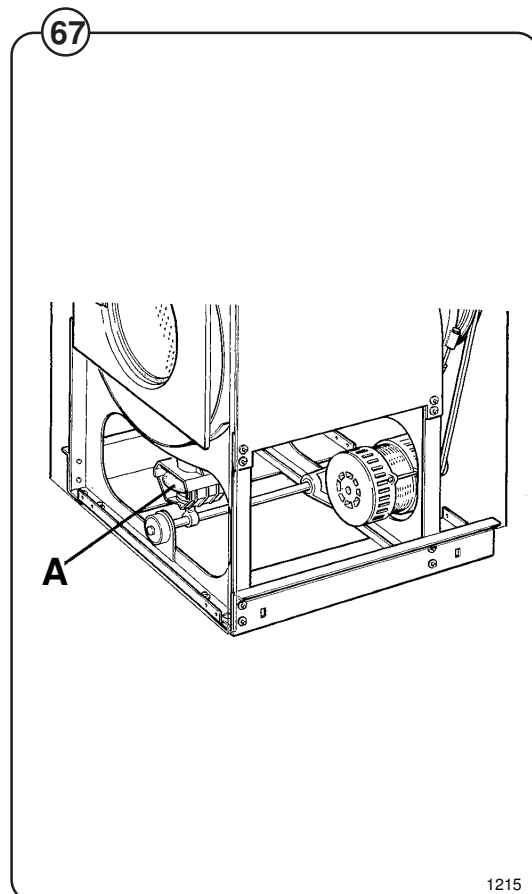
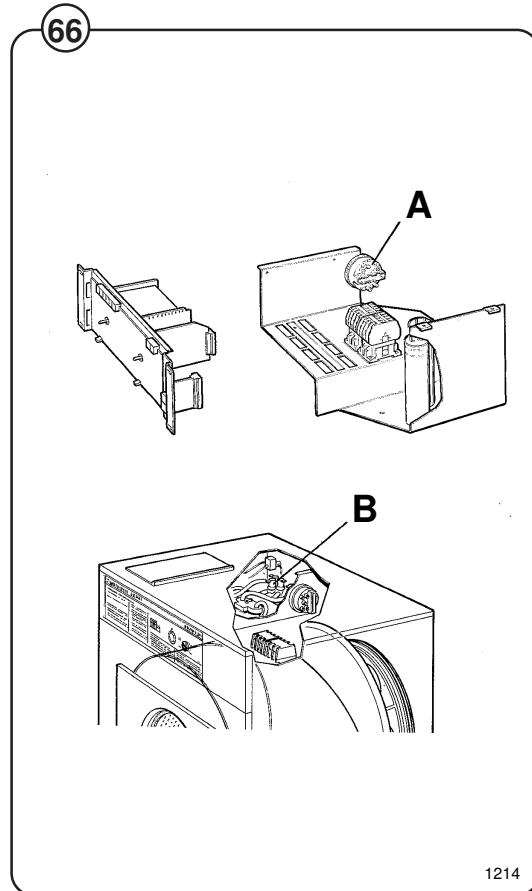

If the machine vibrates excessively.

Fig.

Tighten the mounting bolts.

68

Check that the shipping security has been removed. Refer to Function control on page 14.

