

# **Specifications, Guidelines & Practices**

Fiber Glass / Steel Composition  
& Lightweight Communications  
Shelter Construction

**TABLE OF CONTENTS**

	<u>Page</u>
1.0 GENERAL .....	3
2.0 SPECIFIC CONDITIONS.....	3
3.0 SHELTER SPECIFICATIONS .....	3
4.0 ENVIRONMENTAL CONDITIONS .....	4
5.0 ELECTRICAL AND LIGHTING .....	5
6.0 ALARMS AND FIRE PROTECTION.....	6
7.0 GROUNDING SYSTEM .....	6
8.0 QUALITY ASSURANCE.....	6
9.0 DOCUMENTATION .....	7
10.0 CERTIFICATION.....	7
11.0 INSTRUCTIONS TO BIDDERS.....	7

**NOTICE!**

This manual covers Ericsson and General Electric products manufactured and sold by Ericsson Inc.

This manual is published by **Ericsson Inc.**, without any warranty. Improvements and changes to this manual necessitated by typographical errors, inaccuracies of current information, or improvements to programs and/or equipment, may be made by **Ericsson Inc.**, at any time and without notice. Such changes will be incorporated into new editions of this manual. No part of this manual may be reproduced or transmitted in any form or by any means, electronic or mechanical, including photocopying and recording, for any purpose, without the express written permission of **Ericsson Inc.**

## 1.0 GENERAL

- 1.1 This statement of work and specifications are for shelter (s) to be supplied to **Ericsson Inc.** Private Radio Systems. The shelter supplied shall be a fiberglass-reinforced plastic type as manufactured by *Rohn, VFP* or an **Ericsson Inc.** approved equivalent. **The specifications in this document are intended to set a minimum level which can be modified to meet specific program requirements.**
- 1.2 The specifications contained herein encompass the labor, equipment and materials for a prefabricated fiberglass-reinforced plastic communications shelter. The shelter shall be vandal resistant. The shelter structure shall provide a 2-hour fire rating as defined by the Uniform Building Code and meet Zone 4 seismic requirements. The shelter shall be designed for the explicit use of housing electronic equipment within a controlled atmosphere required for the proper conditions for transmitting and receiving equipment.
- 1.3 Shelters shall incorporate non-porous wall and roof sections, to preclude capillary action, and shall be so designed, and constructed to provide a minimum useful life period of 20 years, without need for major maintenance actions. Manufacturer shall provide shelter maintenance and warranty information.
- 1.4 Shelter manufacturer shall supply and install complete AC wiring systems as required by this specification and in compliance to applicable codes. Electrical systems shall be designed based on preliminary floor plan provided by **Ericsson Inc.**
- 1.5 Manufacturer shall supply and install complete air conditioning and heating systems as required to comply with the environmental conditions of these specifications.
- 1.6 Manufacturer shall be responsible for transporting or for supervising the transporting of the shelter(s) to their respective site.
- 1.7 Manufacturer shall design an I-beam skid assembly based on the requirements of this specification and install the shelter on the assembly. Fabricator will submit I-beam assembly drawings within 10 days after receipt of order.
- 1.8 All shelters shall meet the following specifications and standards:
- (a) Uniform Building Code
  - (b) BOCA National Building Code

- (c) Standard Building Code
- (e) Local Basic Building Codes
- (f) ANSI-A.58.1
- (g) UL 752 requirements for low, medium and high power rifle (when specified)
- (h) National Electric Code latest addition
- (I) IEC - Illuminating Engineering Society

In the event that two specifications conflict, the more stringent shall apply.

- 1.9 The order of precedence to be used for this request for bid is the Statement of Work provided by **Ericsson Inc.** Procurement, specific program requirements and this specification.

## 2.0 SPECIFIC CONDITIONS

- 2.1 The shelter (s) shall be designed to meet the following conditions.
- (a) Seismic Zone 4
  - (b) Ambient temperature of 70° C (158° F) to -55° C (-67° F)
  - (c) Ambient humidity from (0 - 100) percent
  - (d) Winds 145 mph (235 Km/Hr) while on specified foundation.

## 3.0 SHELTER SPECIFICATIONS

- 3.1 The manufacturer shall provide a shelter \_\_\_ feet wide (interior) X 10 feet high (interior) X \_\_\_ long to be specified when the order is placed. Outside dimensions shall be specified by the manufacturer. A typical floorplan is shown in Ericsson drawing 193D1333. A program specific drawing will be provided when the order is placed.
- 3.2 Structural Loading - The shelter shall meet the following loading requirements.
- (a) 200 psf floor loading while lifting or on foundation.
  - (b) 3000 pounds concentrated floor load over 4 square feet area
  - (c) 90 pounds per square foot roof live loading - 7 day duration
  - (d) 1000 pounds concentrated roof load over 3 feet square area
- 3.3 Thermal Performance - Overall u factor  $\leq$  .08 Btu/hr/degrees F

- 3.4 Operating Environment - The shelter shall be sealed to resist dust infiltration and be watertight.
- 3.5 Base Frame - 6 inch I-beam skid assembly on 88 inch centers with cross beams and angles in a fully-welded construction, designed to support equipped buildings in shipping or on foundation. Skids shall also be designed to prevent bending or breaking when the shelter is moved by towing, dragging or lifting.
- 3.6 Exterior Finish - Seamless fiberglass-reinforced polyester resin; 1/8 inch thick on exterior walls and under-floor, 1/4 inch thick on roof; minimum of 15-mil gelcoat or similar finish.
- 3.7 Walls, Floor, Ceiling Material - Plywood sandwich panels in accordance with stressed-skin panel design of the Timber Design and Construction Handbook.
- 3.8 Wall and Ceiling - Shelter inside walls and ceiling shall be finished with a smooth surface and light in color to permit maximum utilization of available light, and shall be designed to support customer loads as specified.
- 3.9 Floor - Shelter shall be equipped with a finished floor of 1/8 inch light colored industrial vinyl tile. The floor shall be supplied with provisions for customer anchoring of equipment as specified.
- 3.10 Door - The shelter door (s) shall be of aluminum exterior, fully insulated and welded construction with stainless steel, ball bearing, tamper proof hinges, 3 point latch, dead bolt lock, hydraulic door closer and a fiberglass awning. If the building is to be bullet resistant, then a similar door with internal steel plate must be installed. An internal lock mechanism shall be employed to allow rapid exit from the building (no key exit). The door shall be equipped with a device to lock the door in the open position in order to prevent the door from being damaged by gusting winds. An illegal entry switch, with form 'C' contacts rated .1 amps at 28 Vdc shall be provided.
- 3.11 Cable Entry Panel - Manufacturer shall provide and install a \_\_\_\_ port/waveguide entry panel with \_\_\_\_ inch sleeves and protective blank covers as manufactured by PolyPhaser (PEEP), Microflect or an **Ericsson Inc.** approved equivalent. The size of the cable entry and number of ports will be specified when the order is placed.
- 3.12 Cable Ladder - Manufacturer shall provide and install 12 inch wide steel cable ladder/tray for cable distribution and seismic bracing of the communication

equipment. The cable ladder shall be Uni-Strut, Rohn, *B-Line*, *VFP, Inc.*, *Newton* or an **Ericsson Inc.** approved equivalent. The actual quantity required will be determined by size of the building and requirements. Location of the cable tray/ladder will be defined when the order is placed.

- 3.13 Storage Cabinet and Table - Manufacturer shall provide a standard 3 drawer file cabinet and folding table. Location will be defined when the order is placed.
- 3.14 Handling - Shelter shall be equipped with removable lifting lugs/eyes to facilitate loading and unloading and placing the shelter on the foundation.

## **4.0 ENVIRONMENTAL CONDITIONS**

- 4.1 The shelter shall be designed and equipped with an environmental control system consisting of air conditioning and heating capable of maintaining the inside temperature under operating conditions, plus sensible and latent heat gains from personnel, at 24°C (75°F) ( ± ) 3°C (5°F). The internal temperature shall not rise above 30°C (84°F) with an outside ambient temperature of 45°C (110°F) (temperatures are to be maintained while the equipment is operating at 75% duty cycle) and shall not fall below 18°C (65°F) with an outside ambient temperature of -35°C (-30°F) while equipment is OFF.
- 4.2 Air conditioning units shall be wall mounted type as manufactured by Bard, Marvair, Carrier or an **Ericsson Inc.** approved equivalent. The units shall be equipped with as a minimum low ambient and compressor anti cycle controls, and integral resistance heat strip (s) and permanent expanded metal dust filter (s).
- 4.3 The air conditioning unit (s) shall be controlled via a separate remote mounted thermostat. If more than one unit is specified a redundant lead lag controller which allows for approximate equal operating time on each air conditioner unit is to be provided. The system shall provide switching to prevent both units from activating at the same time so as to prevent power surge.
- 4.4 The air conditioned air shall be directed toward the center aisle as shown in Ericsson drawing 193D1333 to support the Ericsson station equipment.
- 4.5 All temperature control equipment shall be installed in strict compliance with manufactures instructions and guidelines.

4.6 Heating and cooling calculations based on manufacturer installed equipment and customer installed heat loads shall also be required. Ericsson will provide the manufacturer with heat dissipation information.

## 5.0 ELECTRICAL AND LIGHTING

5.1 The shelter manufacturer shall supply and install a complete working electrical system including the following:

- (a) Main power distribution and provision for service entrance
- (b) Lights, interior and exterior
- (c) Receptacles and circuit breaker for communications equipment as specified when the order is placed.
- (d) Receptacles for customer and user test-equipment shall be on separate circuits.
- (e) Heating and cooling
- (f) Conduit, fittings and wiring
- (g) Lightning and surge protection
- (h) Generator transfer switch, if required

5.2 All equipment and materials furnished and installed shall be new and of the highest quality, and shall be standard products of manufacturers regularly engaged in the production of such equipment and materials. Materials shall also be of the latest standard design, and shall be *Underwriters Laboratories* (UL) listed where applicable.

5.3 Installation shall comply with the latest edition of the National Electric Code, NFPA 70.

5.4 Electrical System (Minimum Requirement) -  
The manufacturer shall supply a *minimum* of 200 ampere, 120/240 VAC, single phase, 60 Hz, or equivalent power with main breaker, snap-in utility power distribution panel as manufactured by General Electric, or an **Ericsson Inc.** approved equivalent. The enclosures shall be NEMA 1 surface mounted. Electrical installation and wiring shall conform to the latest edition of the National Electrical Code and shall consist of the following as a minimum: surface mounted EMT conduit; grounded duplex outlets, one every 4 feet on 3 walls; fluorescent lights (two lamp type fixtures) as required with inside switch; 200 AMP 120/240 VAC main; 20, 30, or 40 position breaker box with a minimum of 16 single pole 20 AMP breakers (as required).

5.5 Circuit breakers for all manufacturer installed equipment and customer loads shall also be provided.

5.6 Manufacturer shall provide and install a Joslyn Model 1265-85, PolyPhaser IS-PM240-BP or **Ericsson Inc.** approved equivalent, AC surge arrester for connection to the incoming power lines.

5.7 A rigid metal conduit, shall be provided and sized accordingly for the service entrance conductors.

5.8 All interior shelter wiring shall be installed in surface mounted electrical metallic tubing (E.M.T.), Article 348 of the National Electric Code shall apply. Other application notes are illustrated in Figure 5.

5.9 All conductors shall be properly sized and rated for the load and application, and, shall be no smaller than # 12 AWG. Conductors shall be copper, type THHN.

5.10 The splicing of conductor wires should be kept to a minimum. Where splices are required, wire nuts shall be used and shall be properly sized, insulated type connectors.

5.11 Conductors shall be continuous from outlet to outlet. Splices shall be made within outlet boxes or junction boxes only.

5.12 A minimum of 6 inches of extra conductor wire shall be provided at each outlet to make splices or joints, except where it is intended to loop through sockets, receptacles and other fixtures without splices or joints.

5.13 Receptacles shall be rated 20 amp, 120V, 3 wire, grounding type, specification grade duplex and shall be on separate circuits. In applications where cabinet power is fed from overhead receptacles, the outlets shall be the twist-loc type. This "twist-loc" (L5-20R or equivalent) receptacle will be defined as part of the original drawings. The number of outlets, locations, and positions will also be defined. Typical spacing for duplex wall outlets is (4) four-foot intervals at 18 inches above finished floor level, except where specified otherwise.

5.14 Manufacturer shall provide a lighting system consisting of quality grade 80 watt surface mounted fluorescent light fixtures equipped with lexan type diffusers, RFI noise suppression filters. The system shall be designed to provide as a minimum illumination of 70 foot candles (fc) at 36 inches above the floor. The fixture shall be installed taking into consideration the location of the communications racks and equipment.

5.15 Exterior lighting shall consist of a 75 watt incandescent bulb. The fixture(s) shall be supplied with vandal resistant lens and photo cell with a switch override.

## **6.0 ALARMS AND FIRE PROTECTION**

6.1 Form "C" type contact alarms shall be provided for the following functions:

- a) Door entry alarm
- b) Smoke alarm
- c) Low temperature alarm
- d) High temperature alarm
- e) Air conditioner fail alarm
- f) Power fail alarm
- g) Generator alarms, if required

The alarm contacts shall be rated for 0.1 amps at 28 Vdc.

6.2 A 4' x 4' wall mounted Telco/alarm board shall be provided for punchblock mounting. The shelter alarms shall be wired to a Type 66 block on the Telco/alarm board.

6.3 The minimum fire protection required for the shelter is a smoke alarm and a Class ABC fire extinguisher. An automatic fire suppression may also be required.

## **7.0 GROUNDING SYSTEM**

7.1 Grounding of the communications shelter must be consistent with the ERICSSON grounding requirements for communications sites and shelters as defined in LBI-39067.

7.2 The manufacturer shall install a "halo" ground system consisting of a #2 AWG stranded green insulated copper halo located approximately 6 inches below the ceiling (see Figure 2 or the Ericsson Grounding Guidelines & Practices, LBI-39067A) with vertical #2 AWG bare/tinned solid copper drops at each corner of the building (see Figure 1 e.g. "PVC" Nipple). At these drop locations a length of bare/tinned solid copper wire capable of extending through and beyond the PVC nipple at least 10 feet shall be coiled and secured to the wall. The customer will use these to connect to the on site grounding system.

7.3 The shelter floor will be supplied with penetrations as per Figure 1 to allow the customer to exit at each corner wall location with the #2 AWG halo ground. Silicone sealer or equivalent shall be supplied for customers use to seal these penetrations after grounding connections have been made. An internal shelter "ground-bar" shall be installed as described in Figure 3.

7.4 Cable trays, ladders, and metal doors shall be bonded to the internal ground ring as illustrated in Figure 4.

7.5 Conduits and conduit couplings shall be bonded to the ground system in a manner consistent with attached Figure 5.

7.6 All coax cable and/or waveguide entry grounds will terminate at the "ground window" or a ***PolyPhaser Earthed Entry Panel*** (PEEP) ground bar installed in an area near to, and/or below the cable multi-port entry panel. A description and example of the ground bar is illustrated in Figure 3.

### **NOTE**

Installation and wire attachment notes are provided on the drawing. ***Use of the "anti-oxidant" at all dissimilar metal connections is highly recommended!***

7.7 Grounding of electrical power and surge suppression equipment shall be done in strict compliance to the latest edition of the National Electric Code and manufacturers data.

## **8.0 QUALITY ASSURANCE**

8.1 The shelter manufacturer shall have a quality assurance program to ensure that its buildings meet the industry standards. Through this program incoming and in process inspections, components, assemblies, and finished shelters shall be checked for compliance with customer specifications, engineering specifications and drawings. An inspection log shall also be maintained with inspection disposition recorded by the Quality Assurance inspector. These records shall be available for customer inspection upon request. The major inspection categories are I-beam skid, framing, assembly, fiberglass, steel assembly, electrical, finish, grounding and preparation for shipping.

8.2 All equipment and hardware shall be installed in the shelter using best commercial practices. All wall and

floor mounted equipment shall present a neat and symmetrical appearance and shall be installed to withstand shock and vibration due to shipping.

- 8.3 Shelter and accessories, when finished, shall be complete in every respect and ready for use intended.

### 9.0 DOCUMENTATION

- 9.1 Manufacturer shall submit, after receipt of order, preliminary drawings and documentation consisting as a minimum the following.

- (a) Shelter layout and structural dimensions. Included shall be drawings and applicable data on equipment included as part of the shelter.
- (b) A legend which identifies major components and systems.

- 9.2 **Ericsson Inc.** will after receipt of preliminary drawings and design information review and approve and return one signed copy with one of the following:

- (a) Approved: Prints so marked will authorize the manufacturer to proceed with fabrication of the shelter.
- (b) Approved as noted: Prints so marked will authorize the manufacturer to proceed with the fabrication of the shelter only after the necessary corrections to drawing have been completed.
- (c) Not approved: The manufacturer shall make the corrections on the drawings and will be required to resubmit for customer approval. The time required for such resubmittals of drawings does not entitle the manufacturer to any extension of time. However, customer may grant extension upon request if time permits.

**NOTE**

**Construction of the shelter shall not begin until customer acceptance of the preliminary drawings.**

- 9.3 The manufacturer shall also provide upon completion the following:

- (a) One set of "as-built" drawings and parts list shall be completed and provided with the shelter upon shipment. An Operation and Maintenance Manual shall be provided with each shelter system. Included in this manual as a minimum will be

manufacturers data and warranty information on all available electrical systems and supplied equipment. Shelter start-up information and maintenance procedures are also to be provided.

- (b) Manufacturer shall provide quality assurance acceptance documentation on completion of the shelter.

### 10.0 CERTIFICATION

- 10.1 **Ericsson Inc.** will provide the manufacturer the final site information with purchase order.

- 10.2 It is the manufacturers responsibility to supply **Ericsson Inc.** with any necessary approval or state certification that may be required, PE sealed drawings up to six (6) sets may also be requested.

### 11.0 INSTRUCTIONS TO BIDDERS

- 11.1 The shelter bidder will submit the following information with his proposal:

- (a) Price
- (b) Delivery schedule
- (c) Shipping cost (separately)
- (d) Verification that the shelter will be approved in the State where required.

- 11.2 The manufacturer will guarantee that all materials and workmanship shall be free from defect for a period of one (1) year after delivery.

- 11.3 The manufacturer will guarantee the shelter construction for a period of five (5) years after completion.

- 11.4 The manufacturer will address each paragraph of this specification and explain their compliance or exceptions.

- 11.5 Technical questions regarding this specification should be sent to:

**Ericsson Inc.**  
 Private Radio Systems  
 CSC Bldg, Mountain View Road  
 Lynchburg, Virginia 24502

Attention: G. E. "Buck" Rogers SR  
 Telephone: (804) 528-7836  
 Fax: (804) 528-7129

## Grounding and Application notes:

- a. apply "no-ox" grease to all ground bar of halo ground connections; wipe clean all excess.
- b. bond exterior door and frame to halo ring; see detail G10.
- c. make all connections to ground bar with two-hole lugs.
- d. coil 8 feet of #2 green for future connection to exterior ground ring.
- e. use only brass grounding hardware except where noted; see table below for approved part numbers:
- f. jump all breaks in conduit, junction boxes, connectors, etc., with #6 green.
- g. ground all metal boxes larger than 4x4 and metal framework to the halo ground with #6 green.
- h. select grounding clamps for conduit in accordance with the following table:

CONDUIT SIZE	WIRE SIZE	GROUND CLAMP #
1/2 - 3/4"	#4 - 6	T & B 3846
1/2 - 1"	#14 - 2	T & B 3849
1/2 - 1"	#2 - 6	T & B #2
1/2 - 1"	#4 - 4/0	T & B 3902
1/2 - 2"	#6 - 4/0	T & B 3970
1 1/4 - 2"	#2 - 6	T & B #3
1 1/4 - 2"	#4 - 4/0	T & B 3903
2 1/2 - 3 1/2"	#2 - 6	T & B #4
2 1/2 - 3 1/2"	#4 - 4/0	T & B 3904
4 - 5"	#2 - 6	T & B #5

Application notes for use with the illustrations and figures that follow (1 through 5).



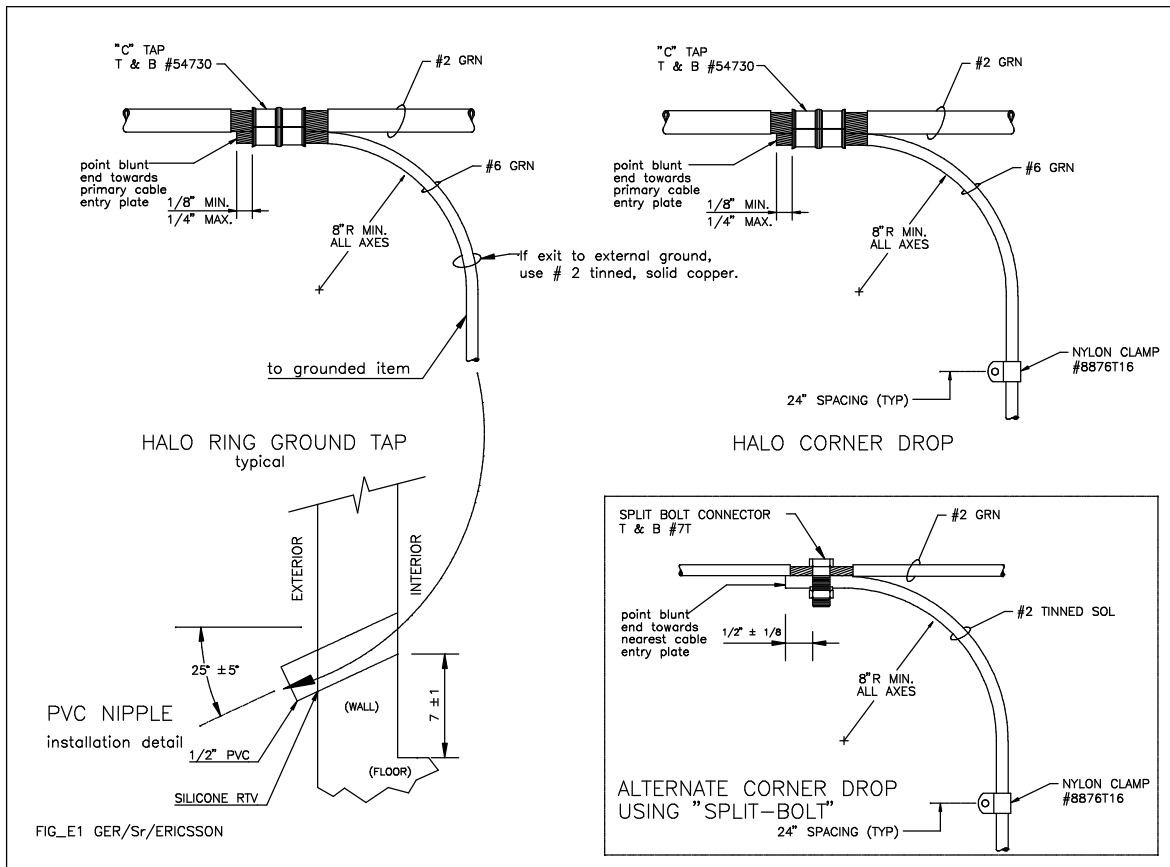

Figure 1 - Some Of The Ways The Inside "Halo" Ground Ring Is Connected To The External Ground Ring.

**NOTE**

The PVC nipple is filled with silicone rubber or a sealant as a moisture barrier and pest deterrent.

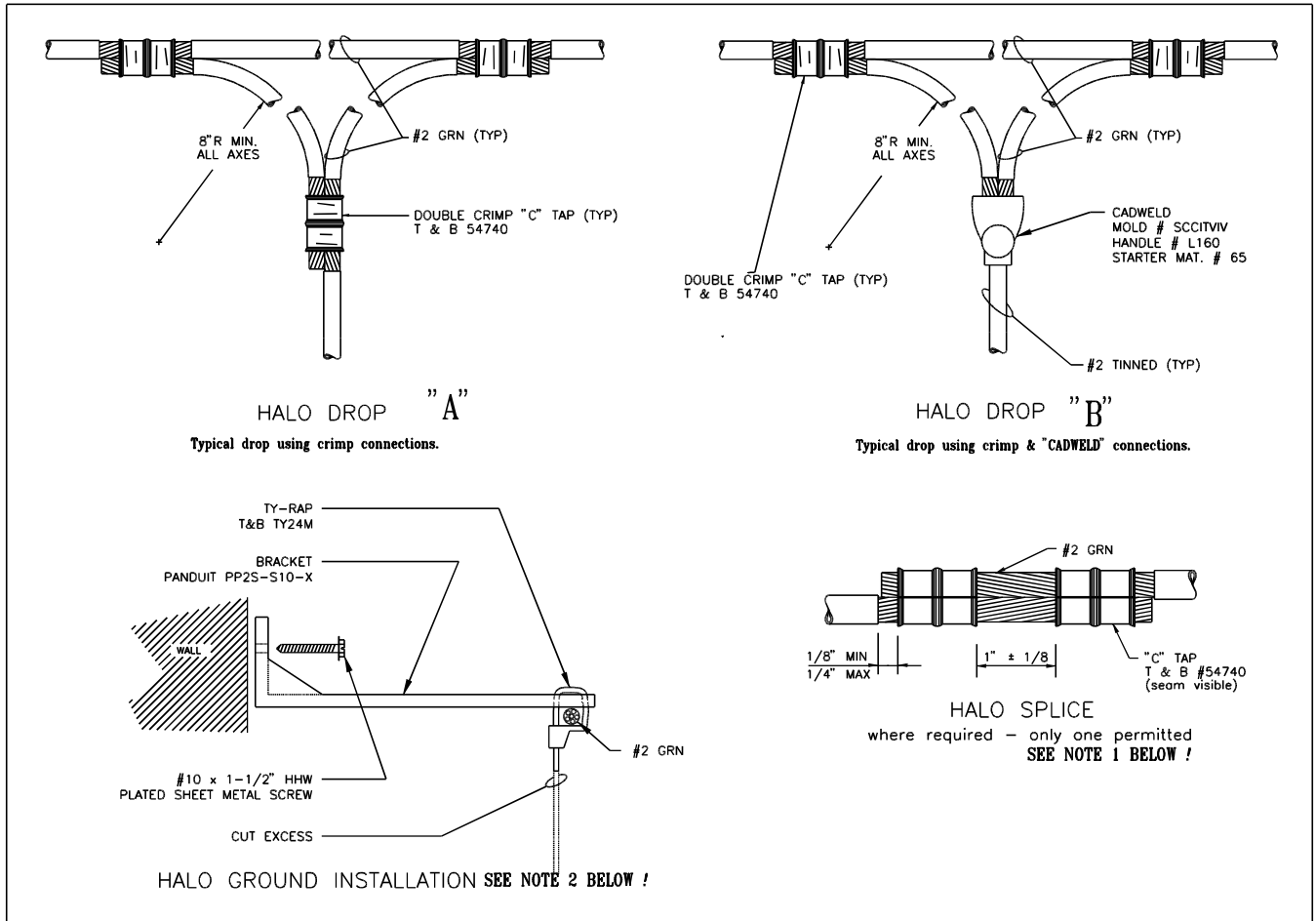

Figure 2 - Internal "Halo" Connections

The drawing below illustrates various means of connecting to the internal "Halo" or ground ring. The drop at "A" denotes the manner T&B crimps are used to attach an exit ground drop from the inside "Halo." The drawing at "B" makes use of a better connection using the "Cadweld" or exothermic connecting method.

**NOTE**

Only one "Halo" splice may be installed per ground ring. Other attachments are to be made using the drop connections shown in these drawings.

**NOTE**

The illustration "*HALO GROUND INSTALLATION*" represents one method used to attach the "halo" to the inside wall.

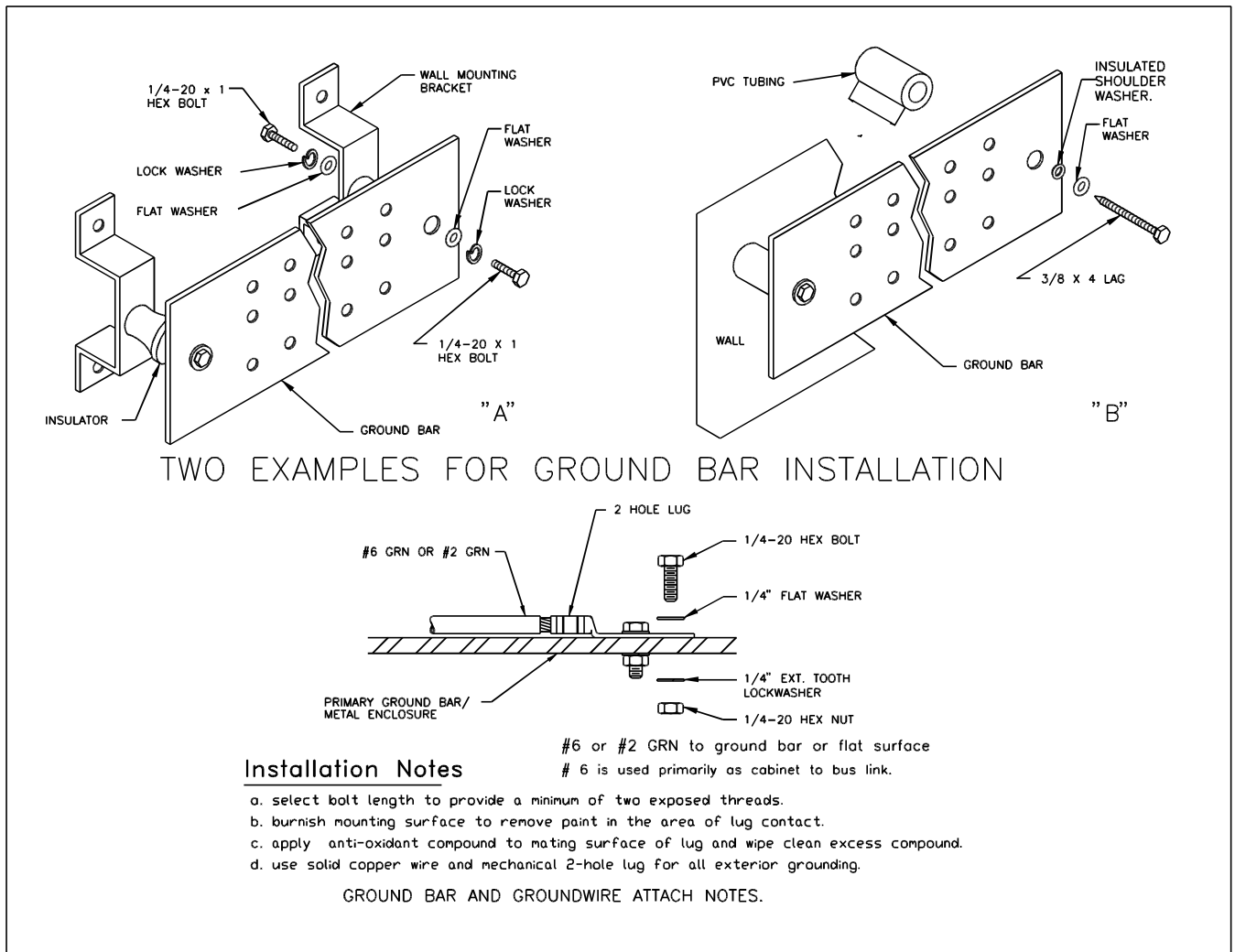

Figure 3 - Two Examples For Ground Bar Installation

When using a copper ground bar as a common point for internal shelter grounding, use one of the two methods shown below to attach the ground bar to communications shelter wall.

**NOTE**

At "A" insulators are used to support ground bar, while insulated "shoulder washers" are use at "B" to support the ground bar. In either case, the ground bar should be isolated from the shelter walls, support members, and studs.

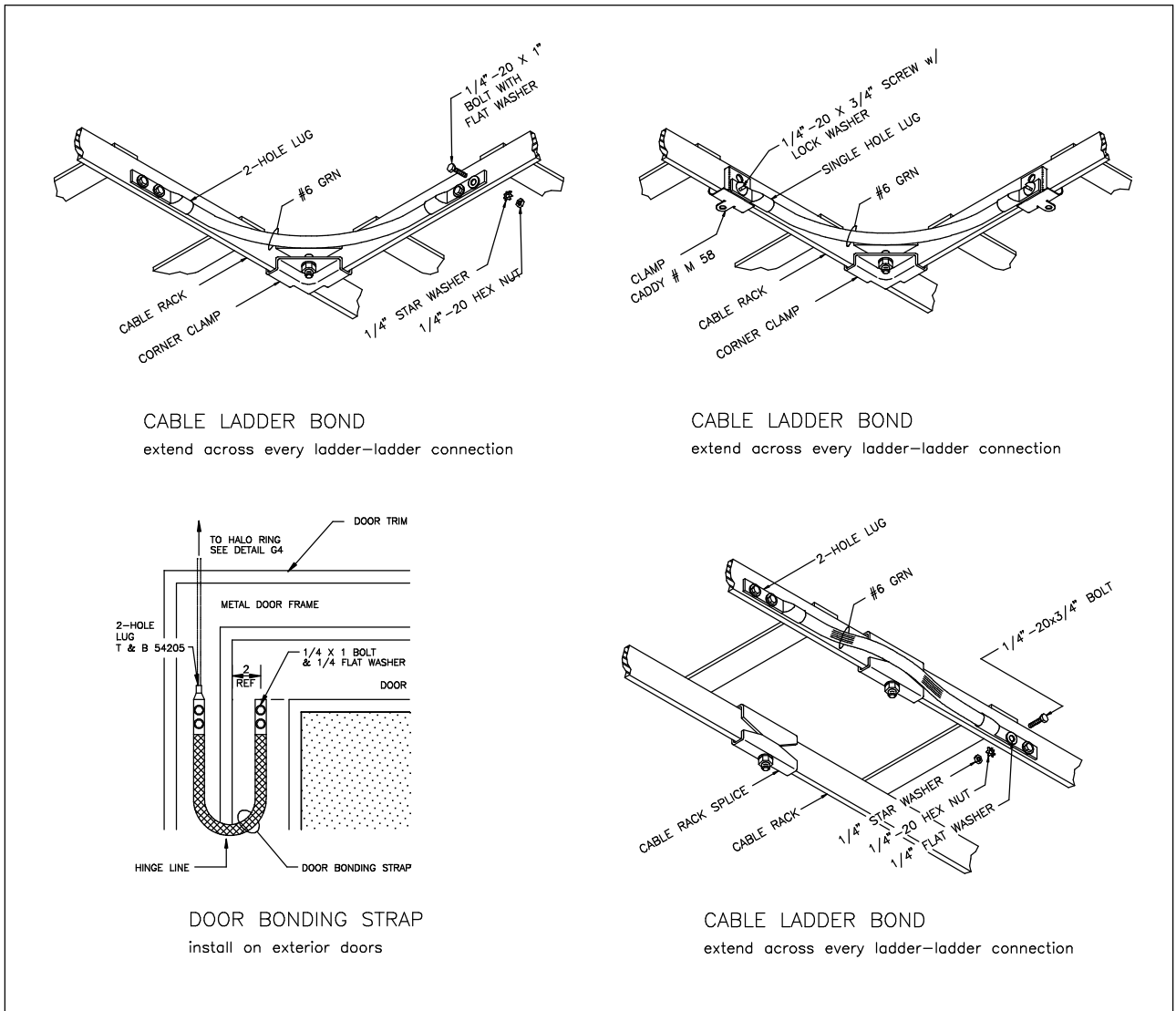

Figure 4 - Bonding Cable Trays and Metal Doors

This drawing illustrates various techniques used when bonding cable trays and metal doors. The connections illustrated above are necessary to preserve ground integrity to all metal objects within the communications shelter.

**NOTE**

If the cable ladder is made of aluminum, use a connection that allows dissimilar metals to become a counterpart. Use of "No-Oxy" compound is recommended (available from PolyPhaser Corp).

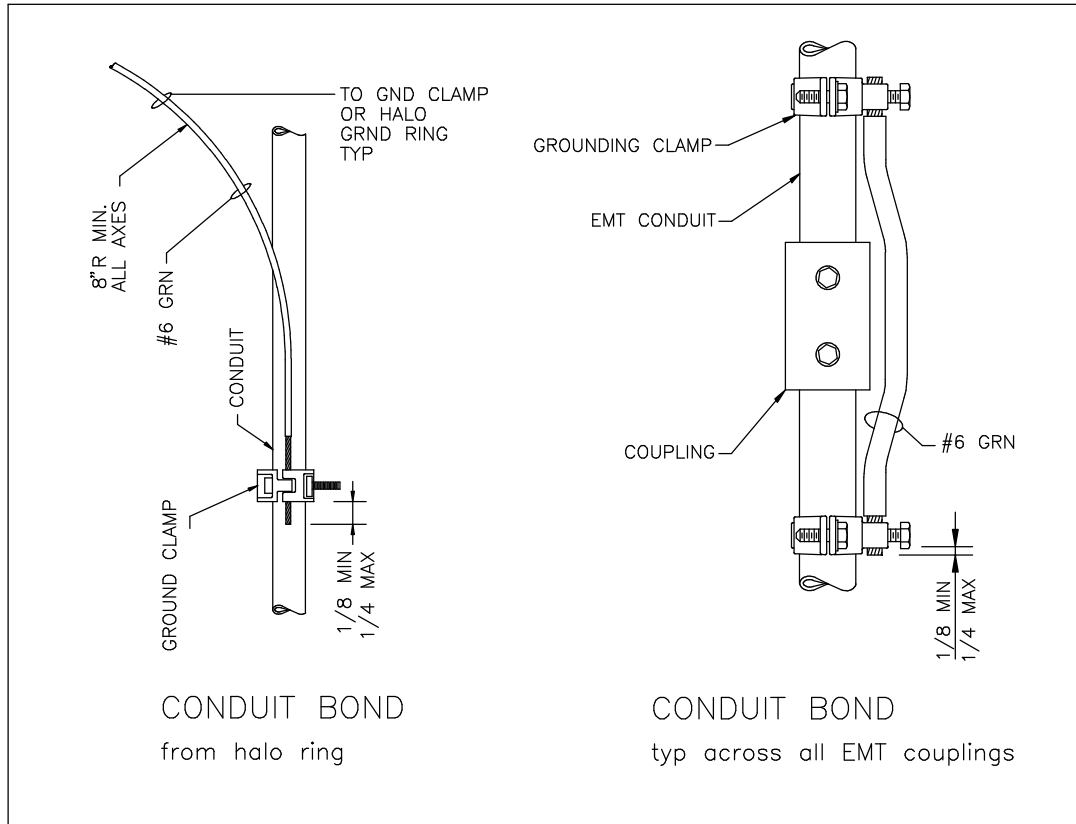

Figure 5 - Typical Conduit Grounding

This drawing illustrates typical conduit grounding techniques.

**NOTE**

**Sharp** bends in *ground wires* or *conduits* must be avoided. **ALL** bends and turns shall be smooth.

**SHELTER WORKSHEET**

Complete the following information about the site(s) for which you are planning a shelter installation, and the individual who should be contacted if additional technical information is required.

*Please print or type*

Customer Name:

Customer System Name:

Site Name:

Site Address:

City:

State/County:

Zip:

**Technical Contact**

Name:

Company Name:

Business Telephone:

<u>Description</u>	<u>Equipment Selection</u>	<u>Quantity</u>
<b>1. Structural Options</b>		
Shelter Size, W_____ x L_____ x H_____ ( ft or meters)		_____
(Inside dimensions nominal)		
<b>Structural Openings</b> .....		
Waveguide Feed-thru Plate		_____
_____” _____port		_____
Floor Cable Entry Slot		_____
PVC Sleeve Opening		_____
Additional Rectangular Openings		_____
<b>2. Architectural Options</b>		
Exterior Finish* _____		_____
Steel Door, W_____ x H_____ (inch or cm)		_____
Bullet-Resistant Door		
SPSA/44 Mag _____		_____
HPR/30.06 _____		_____
<b>Door Accessories</b> .....		
Deadbolt Lock		_____
Lock guard (pick plate)		_____
Hydraulic Door Closer		_____
Door Canopy, W_____ x H_____ (inch or cm)		_____
<b>Interior Options</b> .....		
Insulation, with wood panel fiberglass reinforced plastic		
R-12_____, R-18_____, R-22_____		_____
Floor Tile		_____
Sub-floor		_____
Partition Walls, W_____ x H_____ ( ft or meters)		_____
Partition Wall Doors, W _____ x H_____ ( ft or meters)		_____
Folding Wall Desk, 16 inch x 20 inch		_____
File Cabinet		_____

\* Optional exterior finishes are available, and can be quoted upon request.

**Description** **Quantity**

**3. Electrical Systems**

120/240 VAC, 60 Hz single-phase \_\_\_\_\_100A, \_\_\_\_\_200A, \_\_\_\_\_ Other (Specify)  
 120 VAC, 60 Hz three-phase \_\_\_\_\_100A, \_\_\_\_\_200A, \_\_\_\_\_ Other (Specify)  
 220 VAC, 50 Hz single-phase \_\_\_\_\_100A, \_\_\_\_\_200A, \_\_\_\_\_ Other (Specify)  
 Generator Receptacles  
 \_\_\_\_\_100A, \_\_\_\_\_200A, \_\_\_\_\_ Other (Specify) \_\_\_\_\_  
 \_\_\_\_\_1 Phase, \_\_\_\_\_3 Phase \_\_\_\_\_  
 Generator Mating Plug  
 \_\_\_\_\_100A, \_\_\_\_\_200A, \_\_\_\_\_ Other (Specify) \_\_\_\_\_  
 \_\_\_\_\_1Phase, \_\_\_\_\_3 Phase \_\_\_\_\_  
 Ground Fault Interrupt Receptacles \_\_\_\_\_  
 Additional duplex receptacle, 20A/120V, 60 Hz \_\_\_\_\_  
 Additional A/C receptacle, 20A/240V, 60 Hz \_\_\_\_\_  
 Additional A/C receptacle, 20A/220V, 50 Hz \_\_\_\_\_

**Additional Circuit Breakers (specify rating/quantity).....**

	<i>Amp/Qty</i>	<i>Amp/Qty</i>	
1 -pole, 240V	____/____	____/____	_____
2-pole, 240V	____/____	____/____	_____
3-pole, 240V	____/____	____/____	_____
1 -pole, 240V	____/____	____/____	_____

**Lighting Systems.....**

Additional Fluorescent, 4 ft., two tubes \_\_\_\_\_  
 Wire Guard for fluorescent fixture \_\_\_\_\_  
 Acrylic prismatic lens for fluorescent \_\_\_\_\_  
 Additional Incandescent, 100 watt \_\_\_\_\_  
 Additional Exterior Fixture, 100 watt \_\_\_\_\_  
 Emergency Lighting, 7.5 watt \_\_\_\_\_  
 Photocell \_\_\_\_\_

**Switches and Controls.....**

Timer, \_\_\_\_\_ min. \_\_\_\_\_ hr. \_\_\_\_\_  
 Manual Safety Switch \_\_\_\_\_  
 \_\_\_\_\_100A, \_\_\_\_\_200A, \_\_\_\_\_1Phase, \_\_\_\_\_3 Phase \_\_\_\_\_  
 Manual Transfer Switch \_\_\_\_\_  
 \_\_\_\_\_100A, \_\_\_\_\_200A, \_\_\_\_\_1 Phase, \_\_\_\_\_3 Phase \_\_\_\_\_

**4. Grounding/Lightning Protection**

Ground Bar System \_\_\_\_\_  
 Halo Ground System \_\_\_\_\_  
 Perimeter Ground Bus System \_\_\_\_\_  
 External Ground System \_\_\_\_\_  
 Ground Drop (equipment) \_\_\_\_\_  
 External Ground Drop \_\_\_\_\_  
 Ground Bar, 1/4 inch x \_\_\_\_\_x \_\_\_\_\_ (inch or cm) \_\_\_\_\_  
 Conduit Grounding \_\_\_\_\_  
 Faraday Cage \_\_\_\_\_  
 Surge Arrester \_\_\_\_\_  
 Primary Arrester \_\_\_\_\_ alarms \_\_\_\_\_ 1 Phase \_\_\_\_\_3 Phase \_\_\_\_\_  
 Secondary Arrester \_\_\_\_\_

<u>Description</u>	<u>Quantity</u>
<b>5. HVAC Systems</b>	
<i>Air Conditioning</i> .....	
Wall Unit, ____BTU/H __ 1Phase __ 3 Phase	_____
Heater	
Heat strip ____ Watts	_____
Economizer & heat strip ____ Watts	_____
Lead/Lag Timer	_____
Window Unit, ____ BTU/H	_____
<i>Heating Systems</i> .....	
Forced Air Heater, ____ Watts	_____
Electric Baseboard, ____ Watts	_____
<i>Ventilation Systems</i> .....	
Fan Ventilation System, ____ CFM	_____
Economy/Emergency Thermostat	_____
Battery Vent System	_____
<b>6. Cable Ladders/Wireway</b>	
Cable Ladder, 6 inch W x __ (ft or m) L, __ Gold __ Gray	_____
Cable Ladder, 12 inch W x __ (ft or m) L, __ Gold __ Gray	_____
Cable Ladder, 18 inch W x __ (ft or m) L, __ Gold __ Gray	_____
Cable Ladder, 24 inch W x __ (ft or m) L, __ Gold __ Gray	_____
Junction Tees	_____
<i>Wireways</i> .....	
4 inch x 4 inch, 10 ft section	_____
4 inch x 4 inch, 5 ft section	_____
4 inch x 4 inch, 1 ft section	_____
4 inch x 4 inch, 90° elbow	_____
4 inch x 4 inch, tee section	_____
4 inch x 4 inch, closing plates	_____
<b>7. Safety/Security Options</b>	
<i>Alarm Systems</i> .....	
Mounting Board (telco/alarm)	_____
Terminal Cabinet	_____
Open-door Alarm	_____
Smoke Alarm	_____
High-temp Alarm	_____
Low-temp Alarm	_____
Humidity Alarm, __ High, __ Low	_____
Power-failure Alarm, __1 Phase, __3 Phase	_____
Air Conditioner Fail Alarm	_____
<i>Safety/First Aid</i> .....	
Battery Room Safety Kit	_____
Emergency Eyewash Station	_____
First Aid Center	_____
Fire Extinguisher, __Type, __lb.	_____
Fire Suppression System	_____
Control Panel Upgrade	_____
Double Room Design	_____



Description

Quantity

**8. Spare Parts**

_____	_____
_____	_____
_____	_____
_____	_____
_____	_____

**9. Transportation and Additional Service**

	<b>Ericsson</b>	<b>Vendor</b>
Transportation by:	_____	_____
Off-loading:	_____	_____
Site Setup:	_____	_____
Civil Work & Site Preparation	_____	_____

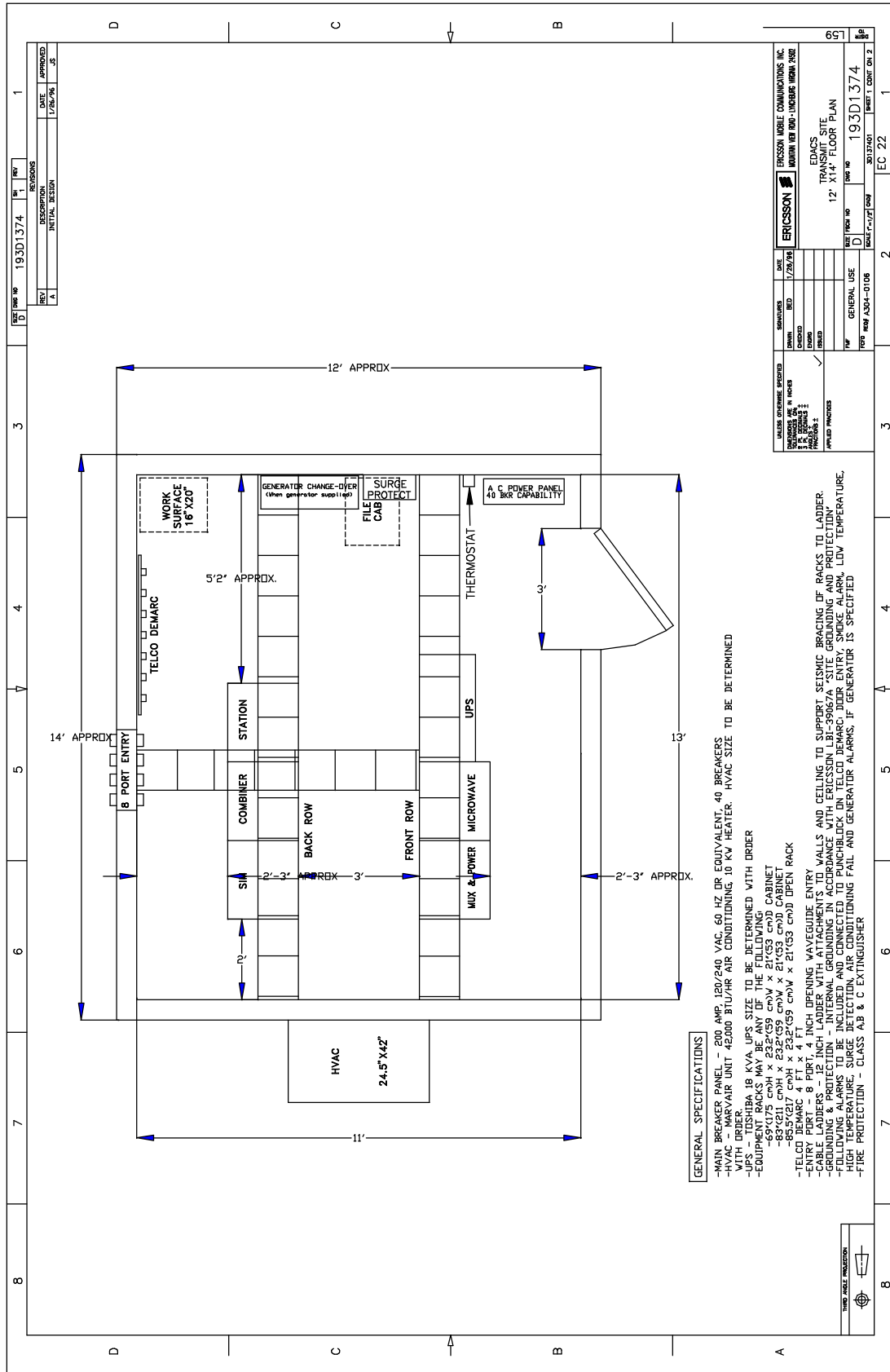

Basic configuration of 12 X 14 fiber glass communications shelter, see notes and general specifications.

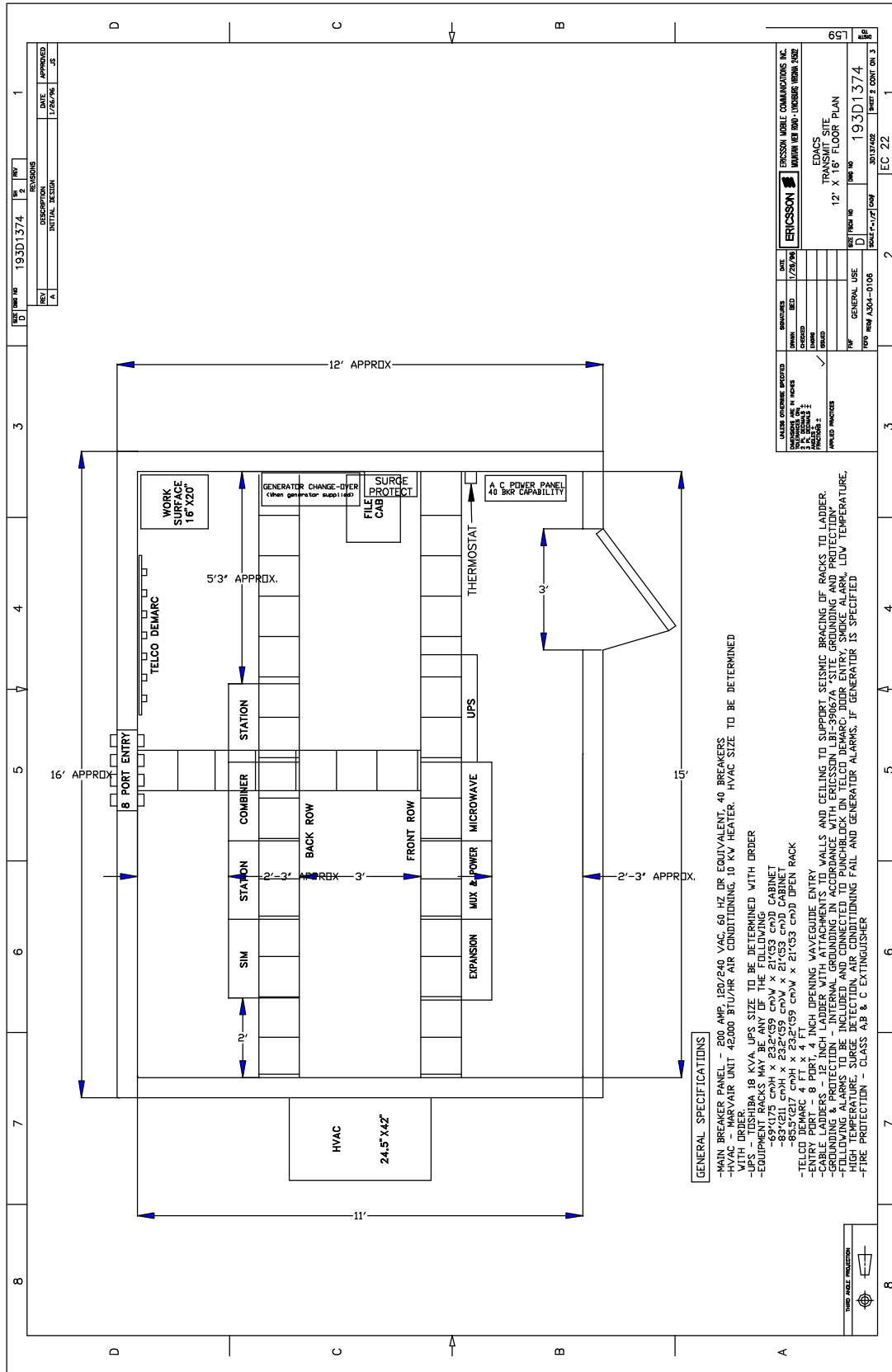

**GENERAL SPECIFICATIONS**

- MAIN BREAKER PANEL - 200 AMP, 120/240 VAC, 60 HZ DR EQUIVALENT, 40 BREAKERS
- FAN DRIBBER/VAIR UNIT 42000 BTU/HR AIR CONDITIONING, 10 KW HEATER. HVAC SIZE TO BE DETERMINED
- UPS - TOSHIBA 18 KVA UPS SIZE TO BE DETERMINED WITH ORDER
- EQUIPMENT RACKS MAY BE ANY OF THE FOLLOWING:
  - 69"X175 CMM X 2327/69 CMM X 21VCS CMM CABINET
  - 85"X1217 CMM X 2327/69 CMM X 21VCS CMM OPEN RACK
- TELCO DEMARC 4 FT X 4 FT
- ENTRY PORT - 8 PORT, 4 INCH OPENING WAVEGUIDE ENTRY
- GROUNDING & PROTECTION - INTERNAL WIRING SHALL BE AIR CELING TO SUPPORT SEISMIC BRACING OF RACKS TO LADDER.
- FOLLOWING ALARMS TO BE INCLUDED AND CONNECTED TO PUNCHBLOCK ON TELCO DEMARC, DOOR ENTRY, SMOKE ALARM, LDV TEMPERATURE, HIGH TEMPERATURE, SURGE DETECTION, AIR CONDITIONING FAIL AND GENERATOR ALARMS. IF GENERATOR IS SPECIFIED
- FIRE PROTECTION - CLASS AB & C EXTINGUISHER

DESIGNED	DATE	1/28/96
CHECKED	DATE	
DRAWN	DATE	
INSTRUMENTED	DATE	
SCALE	AS SHOWN	
ERICSSON WIRELESS COMMUNICATIONS INC. 10000 WILLOW CREEK DRIVE, SUITE 100 FORT WORTH, TEXAS 76154		
PROJECT NO: 193D1374 SHEET NO: 01 OF 03		

Basic configuration of 12 X 16 fiber glass communications shelter, see notes and general specifications.

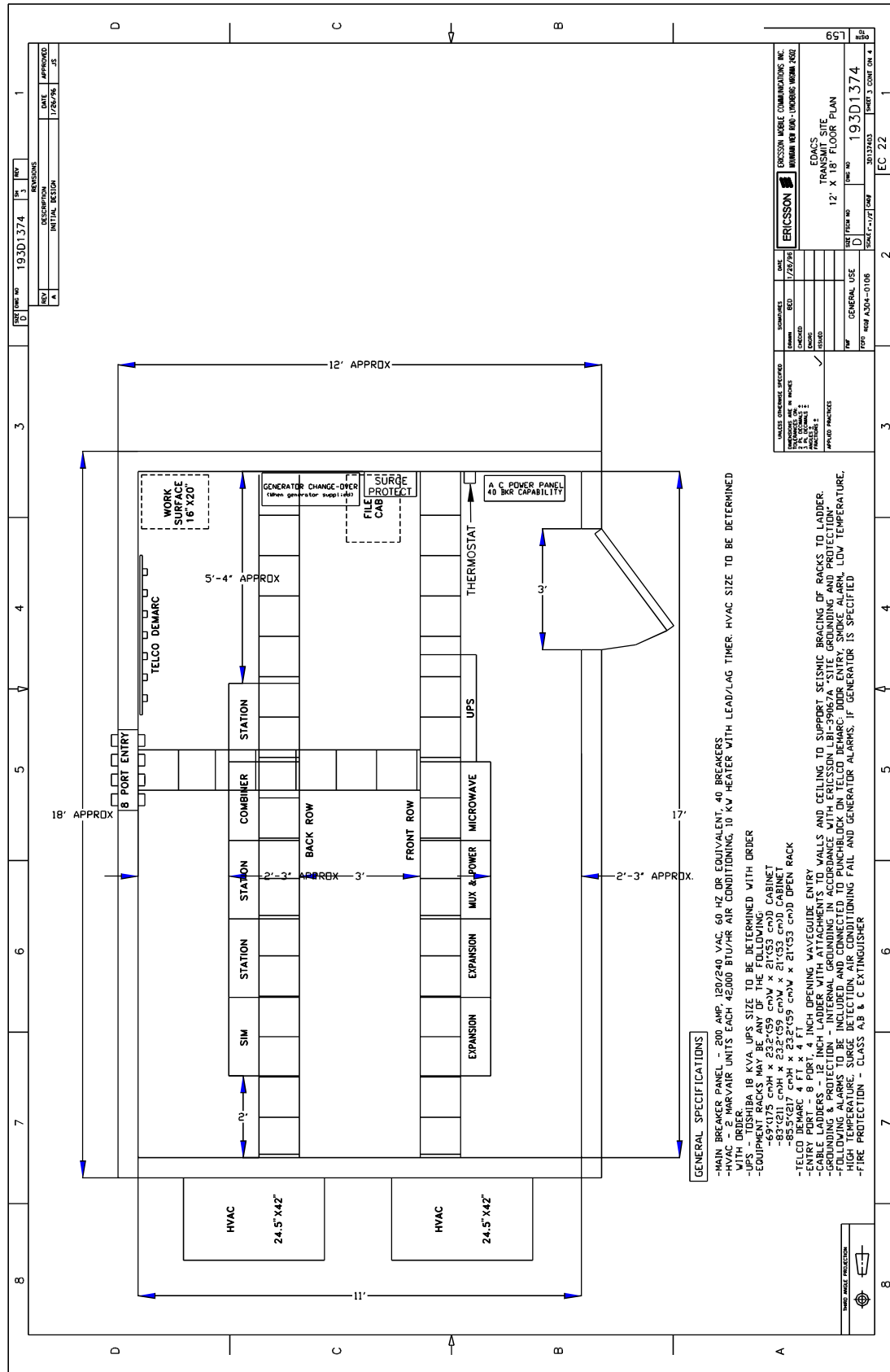

Basic configuration of 12 X 18 fiber glass communications shelter, see notes and general specifications.

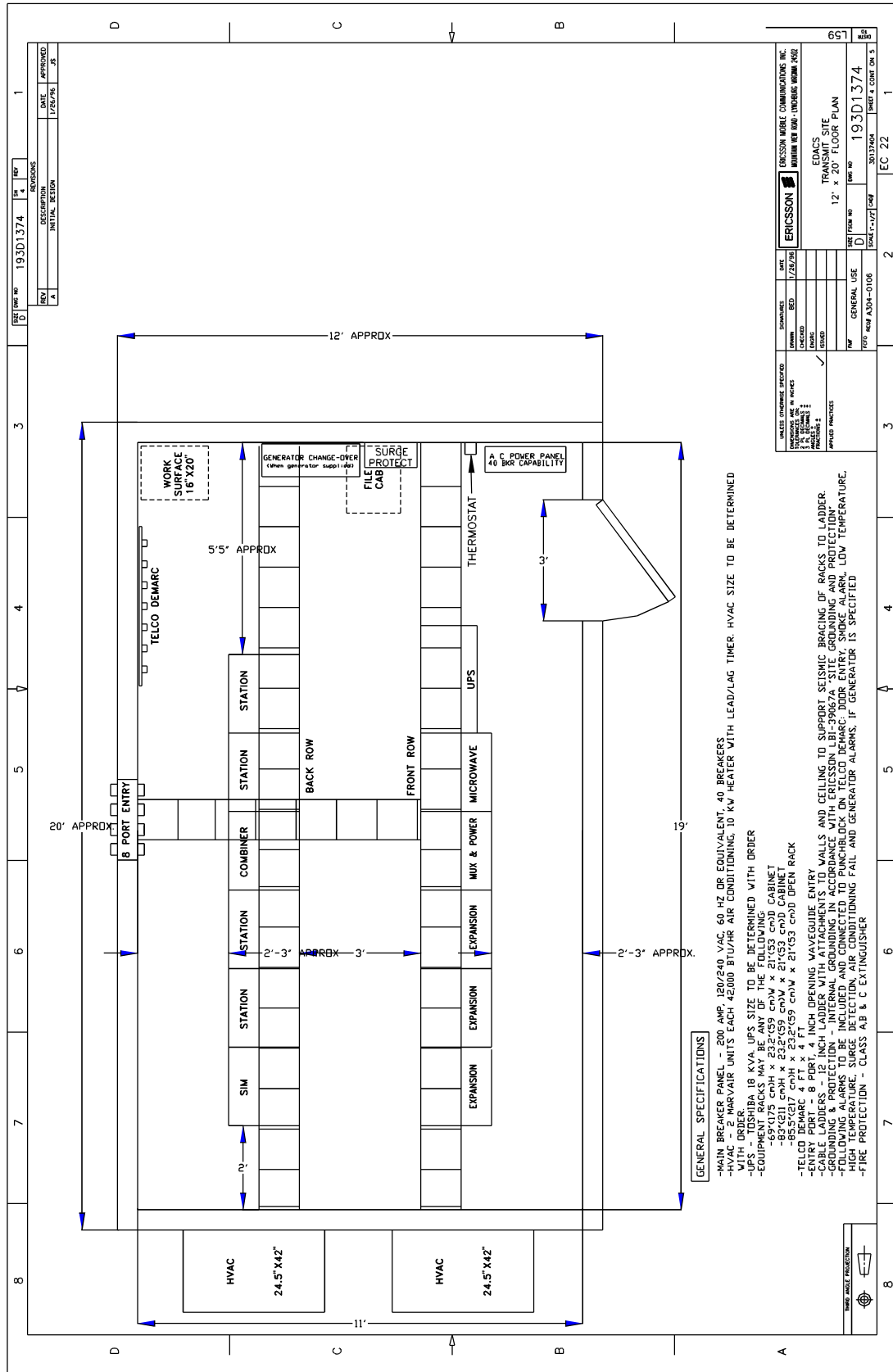

Basic configuration of 12 X 20 fiber glass communications shelter, see notes and general specifications.

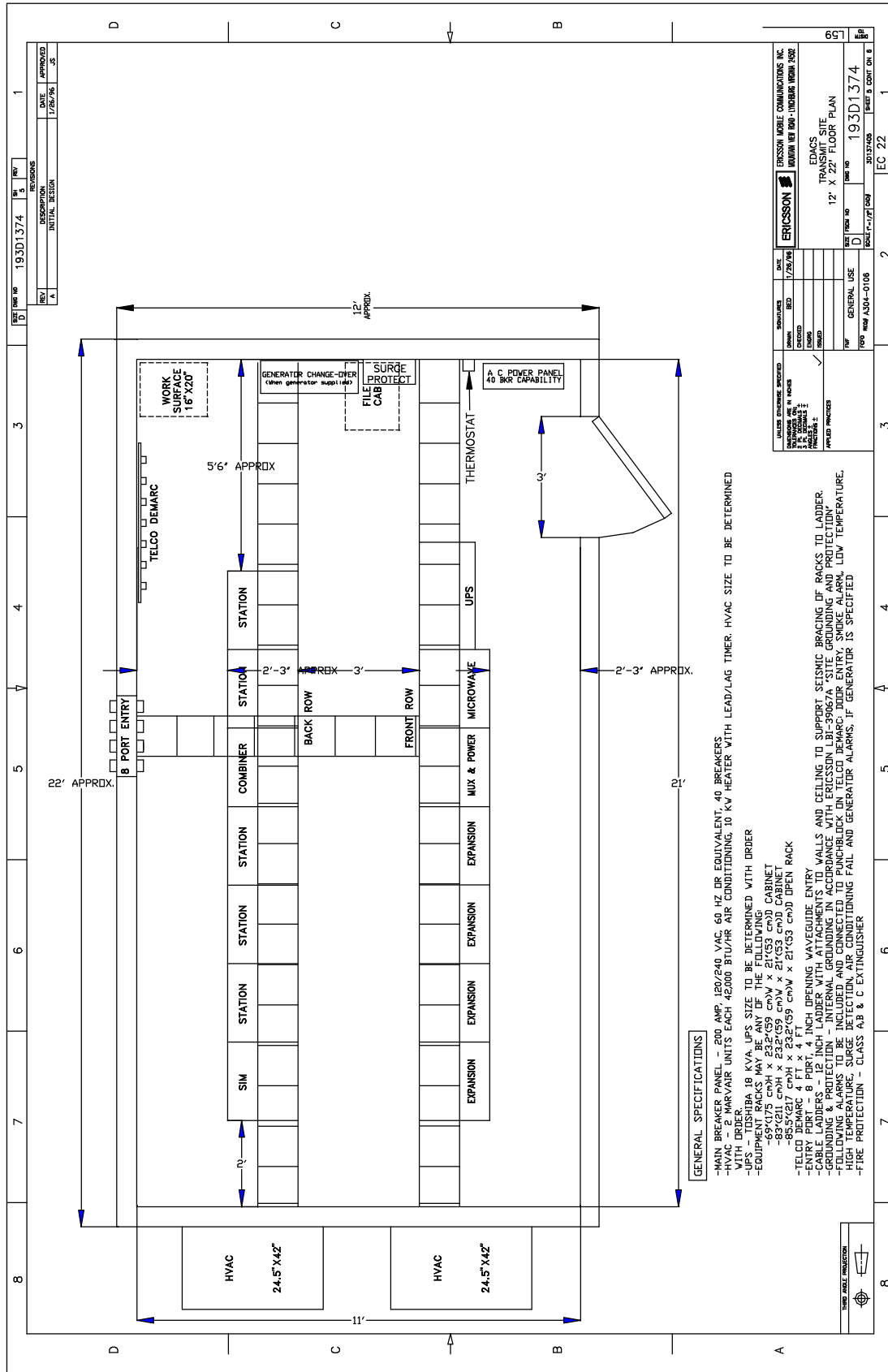

**GENERAL SPECIFICATIONS**

- MAIN BREAKER PANEL - 200 AMP, 120/240 VAC, 60 HZ OR EQUIVALENT, 40 BREAKERS
- HVAC - 2 MARVAIR UNITS EACH 42,000 BTU/HR AIR CONDITIONING, 10 KW HEATER WITH LEAD/LAG TIMER, HVAC SIZE TO BE DETERMINED
- WITH UNDERBAY 18 KVA UPS SIZE TO BE DETERMINED WITH ORDER
- EQUIPMENT RACKS MAY BE ANY OF THE FOLLOWING
  - 69"X175 cmH x 232"X99 cmW x 21"X93 cmD CABINET
  - 83"X175 cmH x 232"X99 cmW x 21"X93 cmD CABINET
  - TELECOM BEAMC 4 FT x 4 FT X 4 FT OPEN RACK
- ENTRY PORT - 8 PORT, 4 INCH OPENING WAVEGUIDE ENTRY
- CABLE LADDERS - 1/2 INCH LADDER WITH ATTACHMENTS TO WALLS AND CEILING TO SUPPORT SEISMIC BRACING OF RACKS TO LADDER, GROUNDING & PROTECTING TERMINALS
- GROUNDING & PROTECTING TERMINALS - 1/2 INCH LADDER WITH ATTACHMENTS TO WALLS AND CEILING TO SUPPORT SEISMIC BRACING OF RACKS TO LADDER, GROUNDING & PROTECTING TERMINALS
- HIGH TEMPERATURE, SURGE DETECTION, AIR CONDITIONING FAIL AND GENERATOR ALARMS, IF GENERATOR IS SPECIFIED
- FIRE PROTECTION - CLASS A,B & C EXTINGUISHER

UNLESS OTHERWISE SPECIFIED	DATE	BY	CHKD	APP'D
REVISIONS	REV	DESCRIPTION	DATE	APPROVED
1	A	INITIAL DESIGN	1/28/96	JS
ERICSSON ERICSSON MOBILE COMMUNICATIONS INC. 12' X 22' FLOOR PLAN TRANSMIT SITE 193D1374 3037400 SHEET 2 OF 2				

Basic configuration of 12 X 22 fiber glass communications shelter, see notes and general specifications.

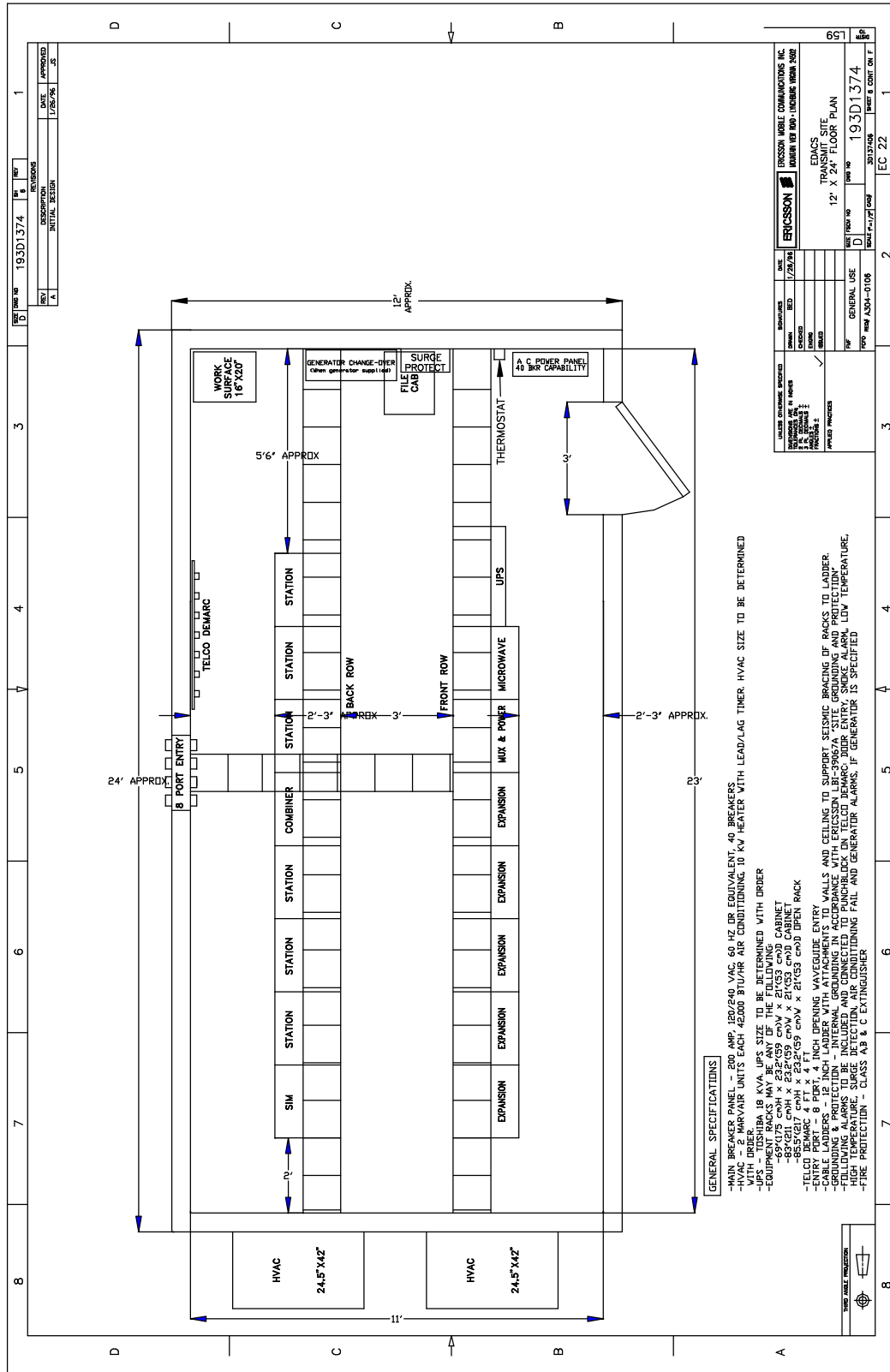

Basic configuration of 12 X 24 fiber glass communications shelter, see notes and general specifications.

