

CATALOG

electrical actuators

BSG Series
Ball Screw Gantry

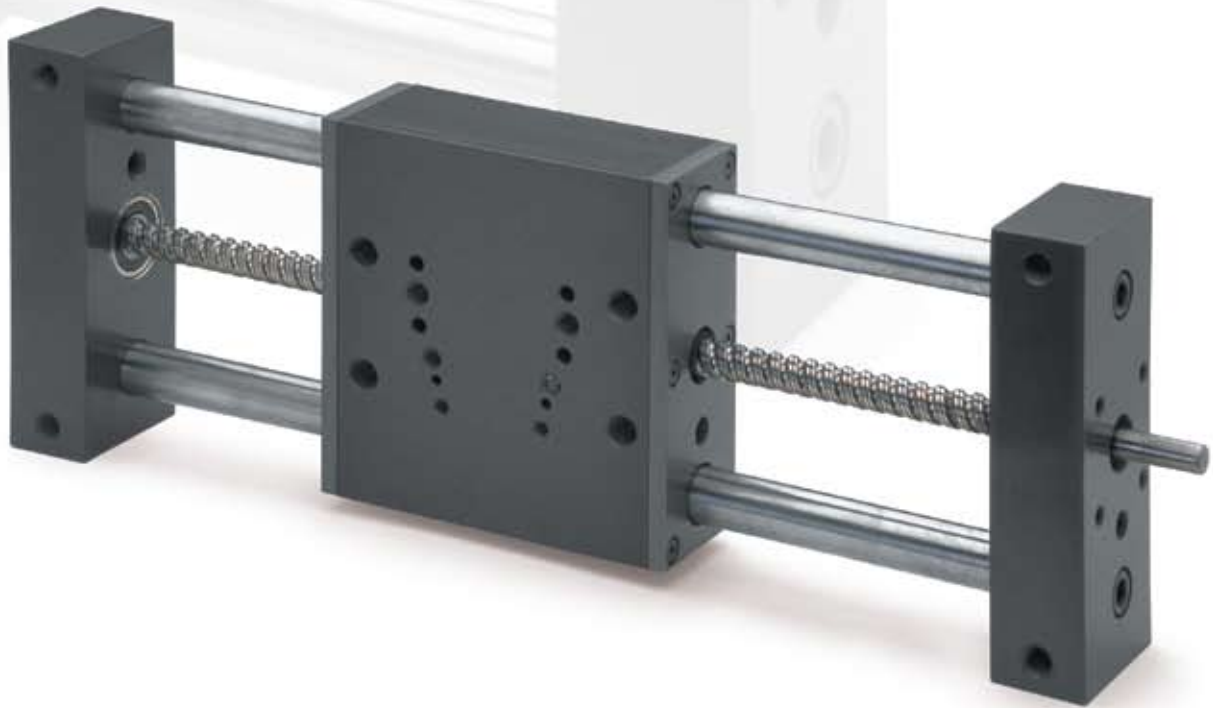

NUMATICS

BSG Series Ball Screw Gantry	3-10
Features and Benefits	3
How to Order	4
Technical Specifications	4
Dimensions	5
BSG Series Motor Mounts	6
NuMate Compatibility	7
Load and Deflection Ratings	8
Speed Calculations	9
Application Request for Belt and Screw Driven Products	10



The BSG-Series is a guided linear motion system utilizing a ball screw to control position. The ball screw provides for precision motion, multiple positioning and incremental movements. The BSG-Series is not designed for high speed applications. Reference the Technical Data section of this catalog for maximum speed ratings.

The BSG-Series carriage assembly is guided by two guide rods and supported by an independent bearing system. The guide rod and bearing system support the load while the ball screw drives the load. Each function is independent of the other. The BSG-Series incorporates Numatics Motion Control's patented *NuMate™* mounting system. *NuMate™* easily combines pneumatic driven products with electrical drive products to create electro/pneumatic systems.

Features and Benefits:

A. Carriage:

Hardcoat Anodized Aluminum lightweight, high durability
NuMate™ Direct Mounting Pattern. other NMC products
 mount directly to carriage without
 adapter or transition plates:
 increased flexibility, reduced cost
 for multi axis applications

B. Ball Screw:

Precision Rolled Thread accurate smooth motion, repeatable to +/- .005
 long lasting, predictable performance
 Hardened Steel hardened to Rc56 to 62
 Hardened Stainless Steel corrosion resistant, hardened to Rc45 to 50
 Rigid Bearing Support both ends of screw are supported by two
 angular contact bearings
 Boot Covers optional

C. Ball Nut:

Recirculating Twin Ball Track greater accuracy, no sliding surfaces
 low friction, higher efficiencies
 Tangential Ball Returns minimizes bearing ball deflection, balls
 enter and exit in a straight path
 Load Locking Spring prevents nut from free falling in the event
 the ball bearings are lost from the nut
 Brush Wipers standard, prohibits contaminants
 from entering ball nut

D. Guide Shafts: (Two Choices)

Hardened Steel hardness Rc 60-65, long life
 Hardened Stainless Steel hardness Rc 50-55, corrosion resistant
 Precision Ground & Polished 15u RMS smooth cycling, low breakaway
 Large Diameter increased load capacity
 Pilot Mounted to Tool Bar maximum rigidity, increased strength

E. Bearings: (Two Choices)

Four Linear Ball Bearings greatest load capacity, self-lubricating,
 built-in seals and wipers, self-aligning
 max. speed 60"/sec
 Four Frelon® Compounded Teflon® self-lubricating, self-aligning,
 long service life, ideal for cleanroom
 max. speed 28"/sec

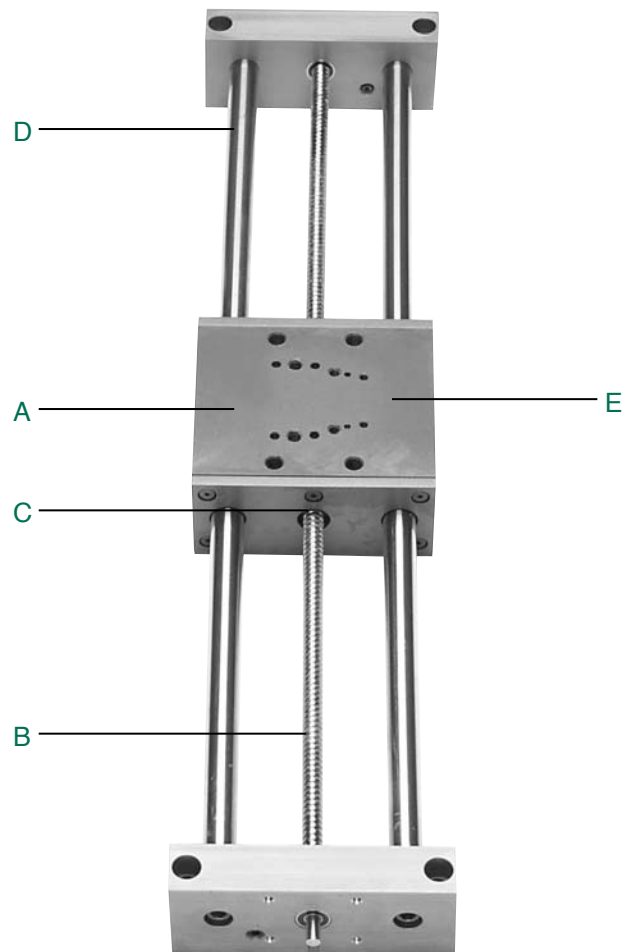



BSG Series Ball Screw Gantry

numatics®

How to Order

BSG 150F 24 L H 3A X

Series & Screw Lead

106B = 0.125 Lead
 150D = 0.200 Lead
 150F = 0.500 Lead
 200D = 0.200 Lead
 200F = 0.500 Lead

Stroke

01 to 54 Inches
 BSG106 limited to 24 inches.

Bearing Option

L = Linear Ball Bearing
 T = Teflon® Bushing

Special Options

X = No Options

Motor Mount

2A = 106 NEMA 23
 2B = 106 NEMA 34
 3A = 150 NEMA 23
 3B = 150 NEMA 34
 4B = 200 NEMA 34
 4C = 200 NEMA 42
 99 = No Mount Supplied

Guide Shaft, Ball Screw & Nut Material

H = Hardened Steel
 S* = Stainless Steel

*Available on BSG 150F and BSG 200F only.

Example order:

Part Number: BSG150F24LH3AX*

Part Description: 150 Series with .500 screw lead, 24" stroke, linear ball bearing, hardened steel guide shafts and lead screw, Nema 23 motor mount and no special options.

* When entering an order, DO NOT use spaces or dashes.

When ordering motor mount separately use the following part number.

DESCRIPTION	PART NO.
106 Series Nema 23	DM 2A
106 Series Nema 34	DM 2B
150 Series Nema 23	DM 3A
150 Series Nema 34	DM 3B
200 Series Nema 34	DM 4B
200 Series Nema 42	DM 4C

Unit Weight Table

	BSG106	BSG150	BSG200
Base unit Weight (lbs.)	7.00	10.35	20.60
Adder/inch of stroke (lbs.)	0.21	0.31	0.56

Add base weight to inch adder X stroke

"Sample weight calculation: Model BSG106 with 12" stroke, 7.00 + (12 x .21)= 9.52 lbs.

Technical Specifications

SERIES	LEAD	SCREW DIAMETER	MAX STROKE	MAX BACKLASH	OPERATING TEMP.	
					LINEAR BALL BEARING	TEFLON BUSHING
106	0.125	0.375	24"	0.007	- 65°F to 158°F	- 65°F to 300°F
150	0.500	0.500	54"	0.007	- 65°F to 158°F	- 65°F to 300°F
-	0.200	0.500	54"	0.007	- 65°F to 158°F	- 65°F to 300°F
200	0.500	0.750	54"	0.009	- 65°F to 158°F	- 65°F to 300°F
-	0.200	0.750	54"	0.009	- 65°F to 158°F	- 65°F to 300°F



BSG Series Dimensions

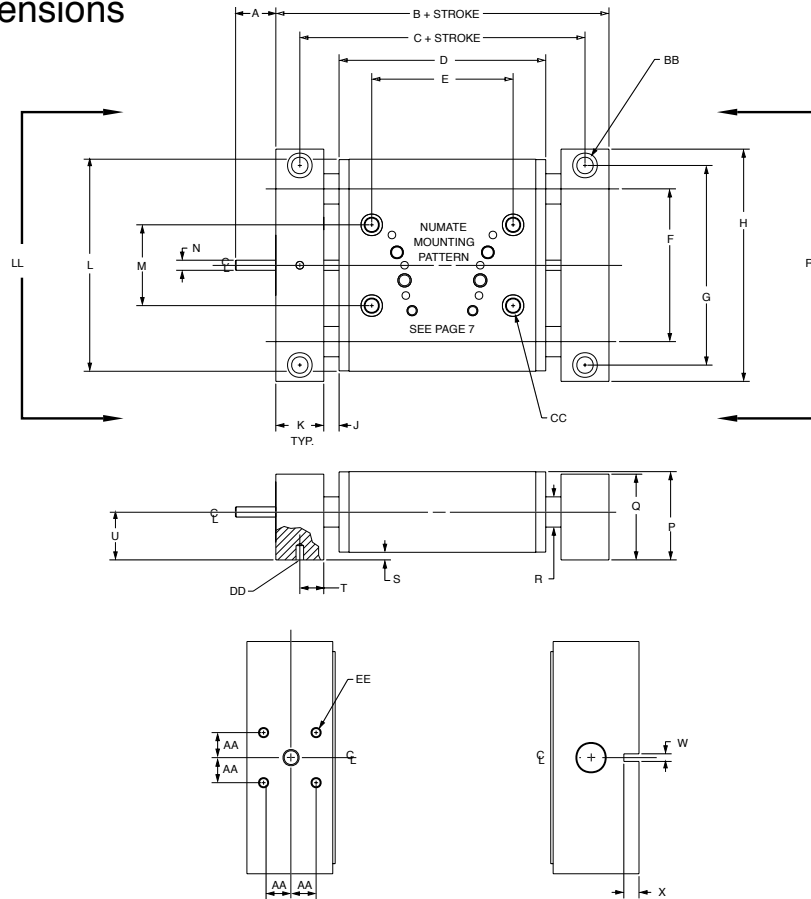

	BSG106		BSG150		BSG200	
A	1.00	(25.4)	1.00	(25.4)	1.50	(38.1)
B	8.40	(213.4)	9.50	(241.3)	11.40	(289.6)
C	7.40	(188.0)	8.31	(211.1)	9.90	(251.5)
D	4.40	(111.8)	5.12	(130.0)	6.40	(162.6)
E	3.25	(82.6)	3.50	(88.9)	4.00	(101.6)
F	3.25	(82.6)	3.78	(96.0)	4.81	(122.2)
G	4.31	(109.5)	4.94	(125.5)	6.28	(159.5)
H	4.95	(125.7)	5.75	(146.1)	7.00	(177.8)
J	1.00	(25.4)	1.00	(25.4)	1.00	(25.4)
K	1.00	(25.4)	1.19	(30.2)	1.50	(38.1)
L	4.63	(117.6)	5.25	(133.4)	6.80	(172.7)
M	1.50	(38.1)	2.00	(50.8)	2.50	(63.5)
N	0.25	(6.4)	0.37	(9.5)	0.50	(12.7)
P	2.12	(53.8)	2.19	(55.6)	2.75	(69.8)
Q	2.00	(50.8)	2.13	(54.1)	2.56	(65.0)
R	0.63	(16.0)	0.75	(19.1)	1.00	(25.4)
S	0.13	(3.3)	0.19	(4.8)	0.25	(6.4)
T	0.499/0.501	(12.67/12.72)	0.593/0.595	(15.06/15.11)	0.749/0.751	(19.02/19.08)
U	1.13	(28.7)	1.19	(30.2)	1.50	(38.1)
W	0.1870/0.1880	(4.75/4.78)	0.1870/0.1880	(4.75/4.78)	0.2500/0.2510	(6.35/6.38)
X	0.30	(7.6)	0.30	(7.6)	0.40	(10.2)
AA	0.62	(15.9)	0.69	(17.5)	0.88	(22.2)
BB	C' bore for 5/16 SHCS Tapped 3/8-24 x 0.59 From Opposite Side.		C' bore for 5/16 SHCS Tapped 3/8-24 x 0.59 From Opposite Side.		C' bore for 3/8 SHCS Tapped 7/16-20 x 0.88 From Opposite Side.	
CC	Tapped 3/8-24 x 0.59 C' bore for 5/16 SHCS From Opposite Side.		Tapped 3/8-24 x 0.59 C' bore for 5/16 SHCS From Opposite Side.		Tapped 7/16-20 x 0.88 C' bore for 3/8 SHCS From Opposite Side.	
DD	0.1870/0.1880 (4.75/4.78)		0.1870/0.1880 (4.75/4.78)		0.2500/0.2510 (6.35/6.38)	
EE	#10-32 x 0.28 DP		1/4-20 x 0.38 DP		1/4-20 x 0.38 DP	

(mm)



BSG Series Ball Screw Gantry

NUMATICS®

BSG Series Motor Mounts

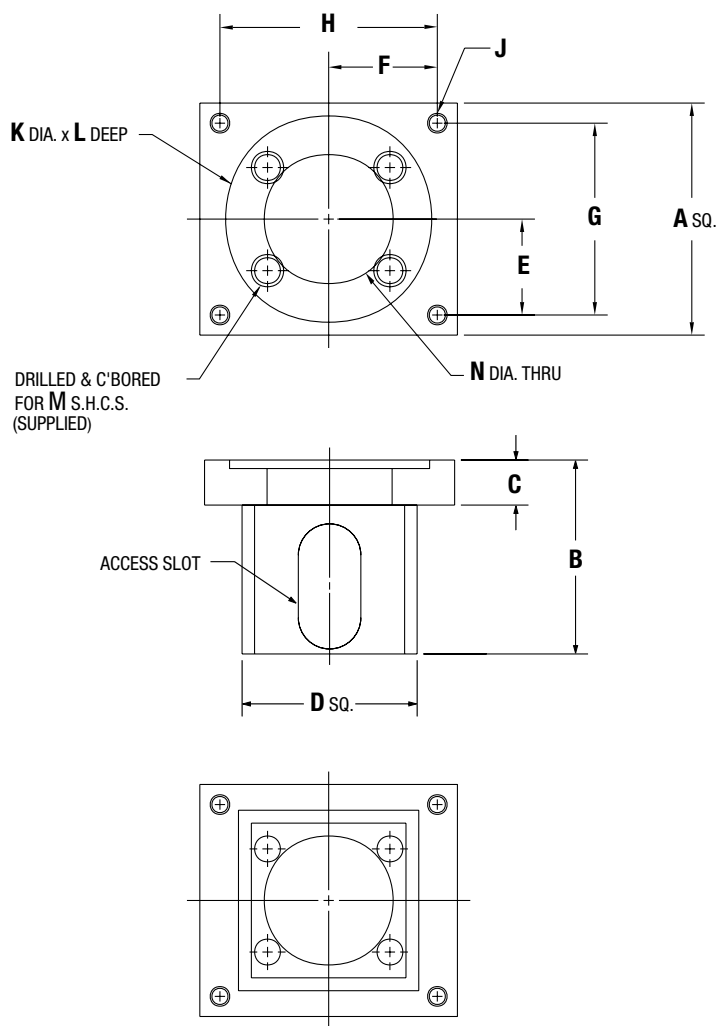

MODEL	BSG 106		BSG150		BSG200	
	FRAME NEMA 23	FRAME NEMA 34	FRAME NEMA 23	FRAME NEMA 34	FRAME NEMA 34	FRAME NEMA 42
A	2.25	3.25	2.25	3.25	3.25	4.25
B	2.26	2.64	2.26	2.64	3.14	3.28
C	0.45	0.45	0.60	0.60	0.60	0.60
D	1.75	1.75	2.00	2.00	2.25	2.25
E	0.93	1.37	0.93	1.37	1.37	1.75
F	0.93	1.37	0.93	1.37	1.37	1.75
G	1.86	2.74	1.86	2.74	2.74	3.50
H	1.86	2.74	1.86	2.74	2.74	3.50
J	#10-24	#10-24	#10-24	#10-24	#10-24	5/16-18
K	1.503/1.506	2.877/2.880	1.503/1.506	2.877/2.880	2.877/2.880	2.503/2.506
L	0.08	0.08	0.08	0.08	0.08	0.14
M	#10-32	#10-32	1/4-20	1/4-20	1/4-20	1/4-20
N	1.25	1.38	1.25	1.5	1.88	1.88



NuMate™ Compatibility

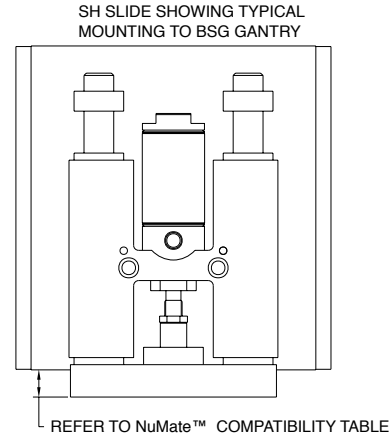
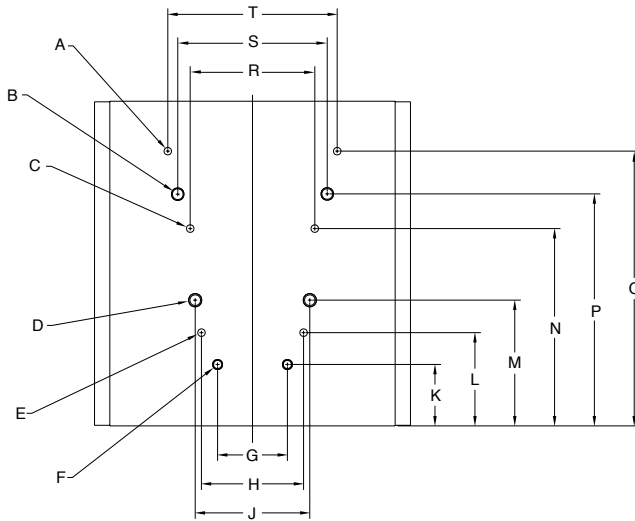

NuMate™ Pattern Dimensional Data (Patent No. 5,560,281)

	BSG106		BSG150		BSG200	
A	0.187/0.188 x 0.37 DP		0.187/0.188 x 0.37 DP		0.250/0.251 x 0.50 DP	
B	5/16-18 x 0.50 DP		5/16-18 x 0.50 DP		3/8-16 x 0.60 DP	
C	0.187/0.188 x 0.37 DP		0.187/0.188 x 0.37 DP		0.187/0.188 x 0.37 DP	
D	1/4-20 x 0.37 DP		5/16-18 x 0.50 DP		5/16-18 x 0.50 DP	
E	0.125/0.126 x 0.25 DP		0.187/0.188 x 0.37 DP		0.187/0.188 x 0.37 DP	
F	#10-32 x 0.33 DP		1/4-20 x 0.37 DP		5/16-18 x 0.50 DP	
G	1.25	(31.8)	1.50	(38.1)	1.87	(47.5)
H	1.38	(35.1)	1.81	(46.0)	1.87	(47.5)
J	1.50	(38.1)	1.87	(47.5)	2.25	(57.2)
K	1.38	(35.1)	1.50	(38.1)	2.38	(60.5)
L	1.69	(42.9)	1.87	(47.5)	2.76	(70.1)
M	1.94	(49.3)	2.25	(57.2)	3.08	(78.2)
N	2.31	(58.7)	2.63	(66.8)	3.52	(89.4)
P	2.69	(68.3)	2.95	(74.9)	3.87	(98.3)
Q	3.06	(77.7)	3.38	(85.9)	4.37	(111.0)
R	1.81	(46.0)	1.87	(47.5)	2.50	(63.5)
S	1.87	(47.5)	2.25	(57.2)	2.75	(69.8)
T	1.87	(47.5)	2.50	(63.5)	3.00	(76.2)

(mm)

NuMate™ Compatibility Table & Edge Reference

	BSG106		BSG150		BSG200	
	Inches	(mm)	Inches	(mm)	Inches	(mm)
SH056	0.50	(12.7)				
SH075	0.40	(10.2)	0.84	(21.3)		
SH106	0.22	(5.6)	0.65	(16.5)	0.52	(13.2)
SH150			0.30	(7.6)	0.16	(4.1)
SH200					0.13	(3.3)
B04	0.11	(2.8)				
B06	0.40	(10.2)				
B08	0.99	(25.2)				
LC056	-0.14	(-3.6)				
LC075	-0.35	(-8.9)	0.09	(2.3)		
LC106	-0.85	(-21.6)	-0.41	(-10.4)	-0.54	(-13.7)
LC150			-0.89	(-22.6)	-1.02	(-25.9)



BSG Series Ball Screw Gantry

NUMATICS

BSG Load and Deflection Ratings

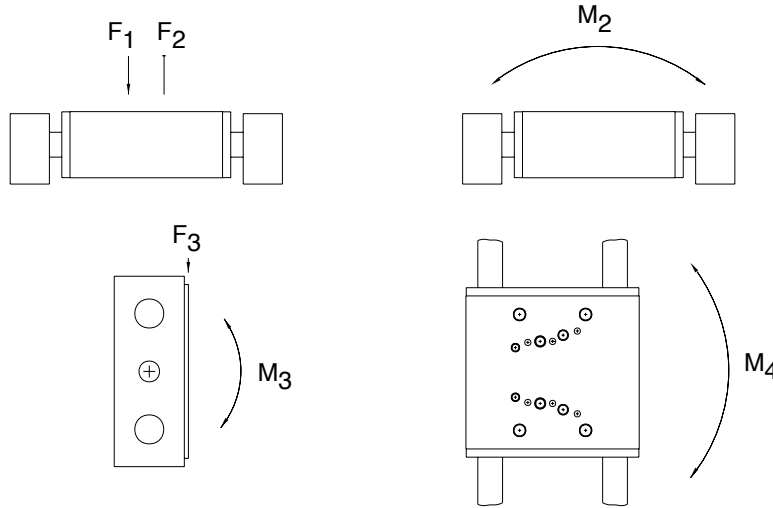

Load Rating in (lbs) For Dynamic Loads, Linear Ball Bearing F1/F2/F3

Ball Screw

STK (IN) SERIES	6	12	18	24	30	36	42	48	54	M2	M3	M4	VERTICAL THRUST LOAD IN LBS.
106	80	80	65	50	-	-	-	-	-	140 in lb	341 in lb	341 in lb	Not Recommended
150	300	243	138	101	67	39	24	16	11	209 in lb	592 in lb	592 in lb	550
200	500	500	433	326	217	124	77	51	36	348 in lb	1242 in lb	1242 in lb	870

Load Rating in (lbs) For Dynamic Loads, Teflon Bushings F1/F2/F3

STK (IN) SERIES	6	12	18	24	30	36	42	48	54	M2	M3	M4	VERTICAL THRUST LOAD IN LBS.
106	63	63	58	50	-	-	-	-	-	100 in lb	238 in lb	238 in lb	Not Recommended
150	175	141	119	101	67	39	24	16	11	146 in lb	414 in lb	414 in lb	310
200	350	350	309	251	217	124	77	51	36	243 in lb	869 in lb	869 in lb	430

Position A

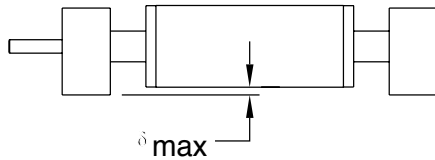

Position B

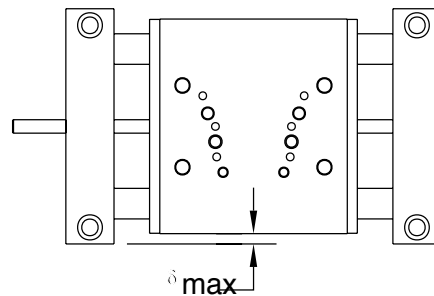

Deflection Formulas

POSITION A

$$\text{BSG106 } \delta_{\max} = \left[(\text{LOAD}) \left(\frac{\text{STROKE}}{2} - 1.200 \right)^3 \left(2 + \frac{19.5}{\text{STROKE} - 2.40} \right) 4.6491 \times 10^{-8} \right] + [\text{STROKE} + 5.975]^4 1.0311 \times 10^{-9}$$

$$\text{BSG150 } \delta_{\max} = \left[(\text{LOAD}) \left(\frac{\text{STROKE}}{2} - 1.500 \right)^3 \left(2 + \frac{18.0}{\text{STROKE} - 3.00} \right) 2.2515 \times 10^{-8} \right] + [\text{STROKE} + 7.913]^4 7.2282 \times 10^{-10}$$

$$\text{BSG200 } \delta_{\max} = \left[(\text{LOAD}) \left(\frac{\text{STROKE}}{2} - 1.828 \right)^3 \left(2 + \frac{21.9}{\text{STROKE} - 3.66} \right) 7.1055 \times 10^{-9} \right] + [\text{STROKE} + 7.043]^4 4.0626 \times 10^{-10}$$

POSITION B

$$\text{BSG106 } \delta_{\max} = \left[(\text{LOAD}) \left(\frac{\text{STROKE}}{2} - 1.200 \right)^3 \left(2 + \frac{19.5}{\text{STROKE} - 2.40} \right) 3.2544 \times 10^{-8} \right] + [\text{STROKE} + 5.975]^4 1.0311 \times 10^{-9}$$

$$\text{BSG150 } \delta_{\max} = \left[(\text{LOAD}) \left(\frac{\text{STROKE}}{2} - 1.500 \right)^3 \left(2 + \frac{18.0}{\text{STROKE} - 3.00} \right) 1.5761 \times 10^{-8} \right] + [\text{STROKE} + 7.913]^4 7.2282 \times 10^{-10}$$

$$\text{BSG200 } \delta_{\max} = \left[(\text{LOAD}) \left(\frac{\text{STROKE}}{2} - 1.828 \right)^3 \left(2 + \frac{21.9}{\text{STROKE} - 3.66} \right) 4.9739 \times 10^{-9} \right] + [\text{STROKE} + 7.043]^4 4.0626 \times 10^{-10}$$

LOAD and STROKE values input by customer.



Critical Speed Calculations: Maximum Ball Screw Speed in RPM (N)

	x 0.125 Lead	x 0.200 Lead	x 0.500 Lead
BSG 106	$N = \frac{7727 (4.76 \times 10^6)}{(8.40 + STK)^2} (.8)$	N/A	N/A
BSG 150	N/A	$N = \frac{1.0202 (4.76 \times 10^6)}{(9.50 + STK)^2} (.8)$	$N = \frac{1.0202 (4.76 \times 10^6)}{(9.50 + STK)^2} (.8)$
BSG 200	N/A	$N = \frac{1.5833 (4.76 \times 10^6)}{(11.40 + STK)^2} (.8)$	$N = \frac{1.5543 (4.76 \times 10^6)}{(11.40 + STK)^2} (.8)$

MAXIMUM VELOCITY IN: IN/SEC $V = \frac{(RPM)(SCREW LEAD)}{60} = \text{IN/SEC}$

Drive Sizing Calculations: Ball Screw Rotational Inertia

ROTATING SCREW

BSG 106 $J_{M_s} = .5 \left(\frac{(.0313)(8.4 + STK)}{386} \right) .0361 = \text{IN-LBS-SEC}^2$

BSG 150 $J_{M_s} = .5 \left(\frac{(.0556)(9.5 + STK)}{386} \right) .0650 = \text{IN-LBS-SEC}^2$

BSG 200 $J_{M_s} = .5 \left(\frac{(.1181)(11.4 + STK)}{386} \right) .1463 = \text{IN-LBS-SEC}^2$

To Convert: IN-LBS-SEC² To OZ-IN² ÷ by 1.619×10^{-4}
To Convert: IN-LBS-SEC² To LBS-IN² ÷ by 2.590×10^{-3}

Driving Torque

$T_d = 0.177 P \times L$ (pound-inches)
 T_d = Direct Torque (pound Inches)
P = Load (pounds)
L = Screw Lead (inches/turn)

Backdriving Torque

The backdriving torque (T_b) is the torque created by an externally applied load.

$T_b = 0.143 (P) \times (L) = \text{lb-in}$

Acceleration Torque Under Load

$T_a = \frac{(p \div g) (A) (L)}{2\pi e} = \text{lb-in}$

A = Acceleration (in-sec²)
g = 386 in/sec²
p = Load (lb)
L = Screw Lead (in/turn)
Thermal expansion of screw
= 6.25×10^{-6} in/in /of

Rotational Torque To accelerate the Screw

$T_r = \frac{WR^2 (RPM)}{3700 (t)} = \text{lb-in}$

T_r = Torque (lb-in)
WR² = Inertia (lb-in)
t = Time to accelerate (sec.)

Angular Velocity

$\text{RPM} = \frac{\text{Velocity (inches/min.)}}{\text{Lead (inches/rev.)}}$



**BSG Series
Ball Screw Gantry**



Application Request Form for Belt and Screw Driven Electrical Products

Your Name: _____ Company Name: _____

Phone: _____ Fax: _____ Date: _____

Please Complete the required info in each step:

Stroke (inches): _____ **Load** (pounds): _____ -and/or- **Opposing Force** (pounds): _____

Repeatability: +/-0.005 inches (Screw Drive): -or- +/-0.012 inches (Belt Drive):

Actuator Orientation: Horizontal: -or- Vertical: *Note: Belt Drive Product is not recommended for Vertical Applications*

Check box if carriage is face DOWN: -and/or- Include Degree of Incline: _____ °

Check one:

A) Load is supported by Actuator: (if no skip to STEP 4)

B) Load is pushed by Actuator:

If load is pushed: 1) What supports the load? _____

2) Coefficient of friction? _____

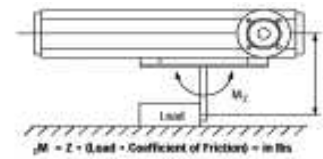

Moment Loading

Check one of the Following:

A) A Moment Condition does not occur: (if so skip to STEP 5)

B). A Moment Condition does occur:

CIRCLE ONE of the following conditions and provide the following information:

Arm Length (inches): _____

Force (pounds): _____

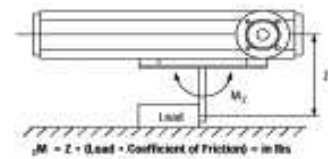
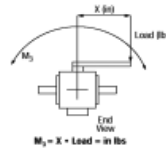
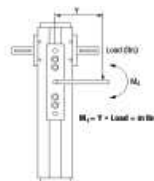

Speed/Cycle Time *Fill out as much information as possible. Must include a move distance and at least 1 other input.*

Move Distance: _____ inches

Velocity: _____ in/sec/

Acceleration: _____ in/sec²

Time: _____ sec

Note: Provide Move Distance and at least 1 other input

If there are multiple stops, check here: and provide Move Distance and at least one other input per stop in the space below:

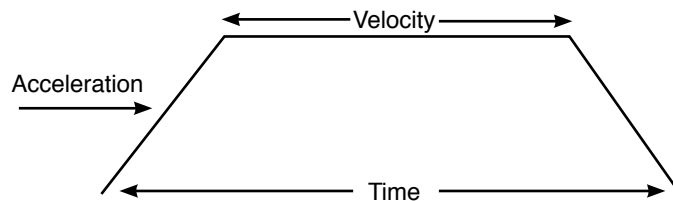

Total Package? Please check all that apply: Motor & Controller Package: Brake:

Customers Controller or PLC will supply host commands: Encoder/Closed Loop:

NUMATICS

*World Class Supplier
of Pneumatic Components*

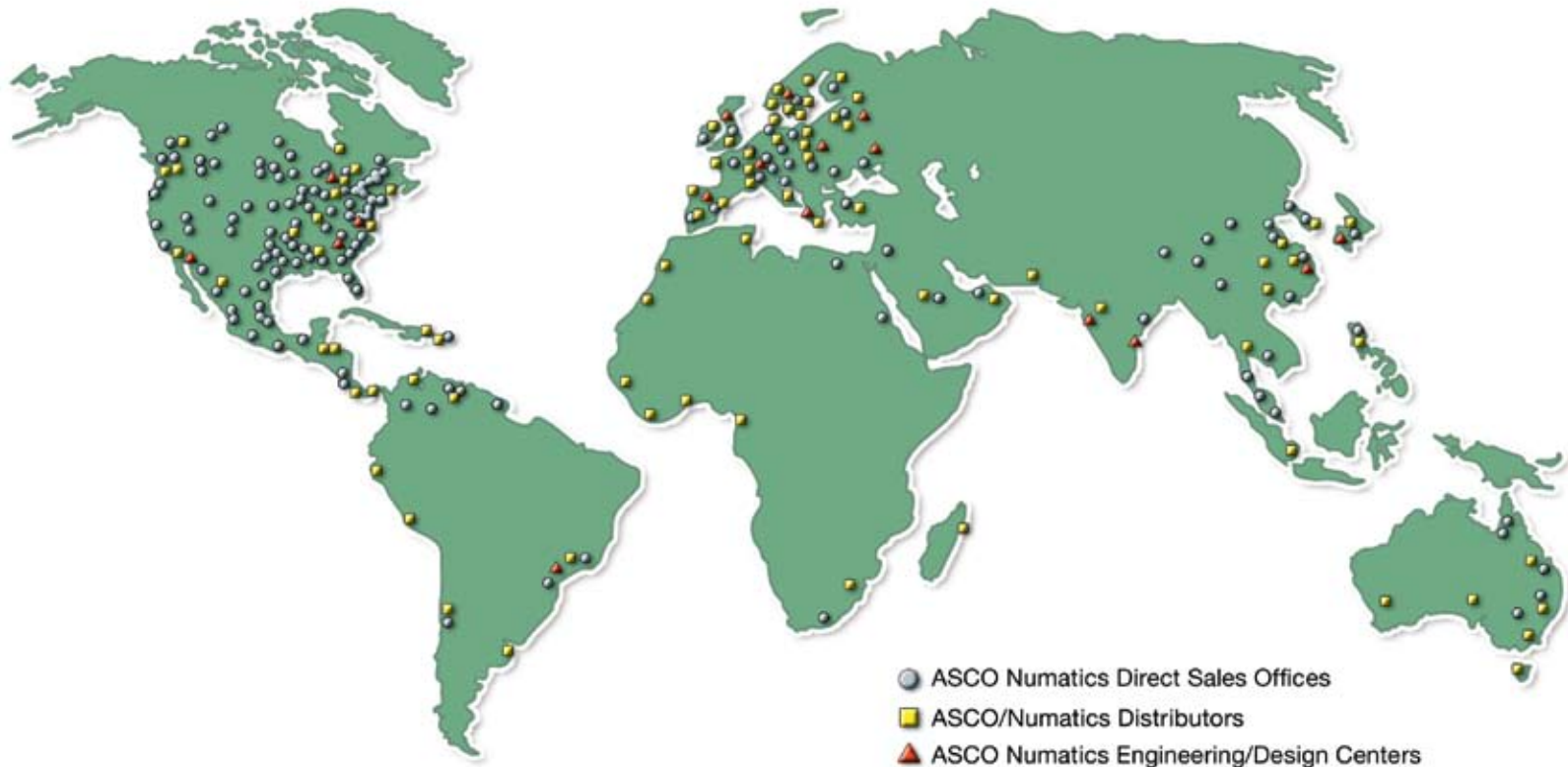

WORLD HEADQUARTERS

USA

Numatics, Incorporated

46280 Dylan Drive
Novi, Michigan 48377

P: 1-888-Numatics
1-888-686-2842

Canada

Numatics, Ltd

P: 519-452-1777

Mexico

Numatics de Mexico S.A. de C.V.

P: 52-222-284-6176

For a comprehensive listing of all Numatics production and distribution facilities worldwide, visit:

www.numatics.com