

Work Truck Step Installation Instructions

Part No's: 501010, 501020, 501030

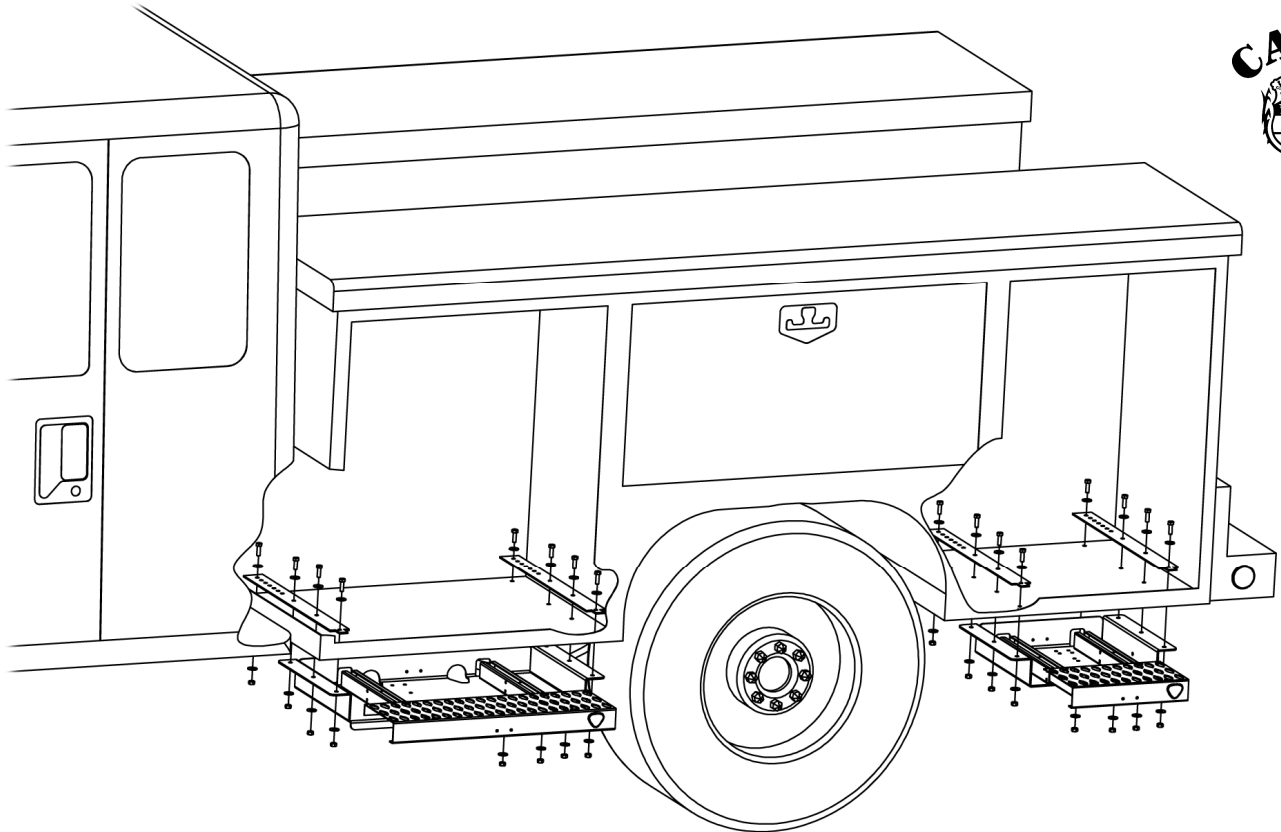

1. **WARNING:** Rear passenger side tool box on some trucks may have an exhaust pipe. The Step assembly may have to be moved forward for proper installation. Some exhaust pipes are flexible and will move some, which may be enough to get the step assembly installed properly.
2. Make sure this step assembly will be mounted to a flat service where access to both sides of the mounting area is available.
3. From underneath the mounting area, position the step assembly in its desired position. Line up the front edge of the step assembly with the edge of the mounting area to insure step assembly is straight.
4. Set the front edge of the step pan back $\frac{1}{4}$ " from the front edge of the mounting area. This will insure that the support straps will fit properly inside.
5. From underneath take a pencil and mark the two front holes in the step pan. Set the step assembly aside.
6. Drill out the marked holes with a $\frac{5}{16}$ drill bit and remove any burrs.
7. Place the step assembly back into position and with the $\frac{5}{16}$ hardware provided tighten the drilled areas to the step assembly.
8. **For boxes that are less than 13" in depth follow these instructions.** With the step in position you now can drill out the other two holes using the holes in the step pan as a guide. Since your box is not as deep, you will not use the back two holes in the step pan. Drill out the two other holes. Remove the step assembly and remove all burrs. Measure the inside of the mounting area and cut the support straps to that dimension. Cut the ends of the support straps that have the holes that are spaced closer to each other. The closer you cut this end to the inside corner of the mounting area, the stronger this installation will be. After cutting, apply some black primer paint on the area that was just cut. Now place the support straps back inside the mounting area and line up the four holes you drilled in the pervious step with the four holes that are in the support straps. Take the $\frac{5}{16}$ hardware and mount the step assembly to the mounting area with the support straps inside. See diagram for exploded view of this. Securely tighten the hardware. Go to step 10.
9. **For boxes that are deeper than 13" in depth follow these instructions.** With the step in position you now can drill out the other four holes using the holes in the step pan as a guide. Take the two support straps and place them inside the mounting area and line up the six holes you just drilled with the six holes that are spaced farther apart. (NOTE: if the support straps are to long, measure the inside of the mounting area and cut the ends of the support straps that have the holes that are spaced closer to each other. The closer you cut this end to the inside corner of the mounting area, the stronger this installation will be. After cutting, apply some black primer paint on the area that was just cut. Now place the support straps back inside the mounting area and line up the six holes you drilled in the pervious step with the six holes that are spaced farther apart in the support straps.) Take the $\frac{5}{16}$ hardware and mount the step assembly to the mounting area with the support straps inside. See diagram for exploded view of this. Securely tighten the hardware. From inside the cabinet take a $\frac{5}{16}$ drill bit and using the holes at the end of the support straps as a guide, drill out the metal of the mounting area. Remove all burrs. Use the remaining $\frac{5}{16}$ hardware and securely tighten the end of the support strap to the mounting area.
10. All moving parts ride on Delrin plastic which will give you smooth, efficient and long lasting functionality.
11. Cut the zip ties from the back of each rail. Now your step is ready to go!
12. To deploy your step out, just push the step in with you foot. To lock it in, do the same thing except push the step in until it locks.

Work Truck Step Installation Instructions

Part No's: 501010, 501020, 501030

WARNINGS!

- ✓ FOR SAFE AND PROPER USAGE OF THIS PRODUCT, THE MOUNTING INSTRUCTIONS MUST BE FOLLOWED CAREFULLY AND COMPLETELY.
- ✓ The manufacturer and distributor of this product are in no way responsible for the consumer's failure to adhere to the warnings and directions of these instructions in the event of damage to the consumer's vehicle, other properties and or personal injury.

Vehicle Application:

All commercial, industrial, utility, fire prevention and service trucks that have tool boxes or a flat platform area that has access to both sides.

MATERIALS NEEDED:

- * Drill motor
- * 5/16 drill bit
- * Pencil
- * 2 – 1/2" wrenches or sockets
- * Possibly a metal cutting device (hacksaw, band saw, grinder, etc)
- * Cutters to cut zip ties
- * Black primer paint (if support straps are cut)

MATERIAL FURNISHED:

- * Step Assembly
- * 2 – Support Straps
- * Hardware installation pack
- * Instruction sheet

Installation time for one step assembly – 1/2 hour