

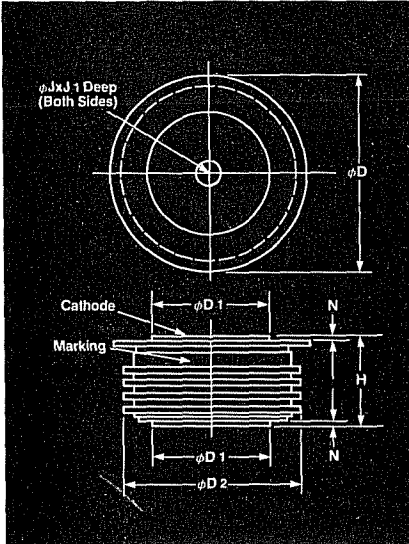

Soft-Fast Recovery RECTIFIER R722 06

650 A. Avg.
Up to 1400 Volts
1.0 μ s*



R722 Outline

Features:

- Fast Recovery Times
- High Surge Current Ratings
- Soft Recovery Characteristics
- Special Selection of t_{rr} or Q_{rr} available
- Lifetime Guarantee

Symbol	Inches		Millimeters	
	Min.	Max.	Min.	Max.
ϕD	2.250	2.290	57.15	58.17
ϕD_1	1.333	1.343	33.86	34.11
ϕD_2	2.030	2.090	51.56	53.09
H	1.020	1.060	25.91	26.92
ϕJ	.135	.145	3.43	3.68
J_1	.075	.090	1.91	2.29
N	.040		1.02	

Creep Distance—1.15 in. min. (29.21 mm).
Strike Distance—.94 in. min. (23.88 mm).
(In accordance with NEMA standards).
Finish—Nickel Plate.
Approx. Weight—8 oz (227g).
1. Dimension "H" is clamped dimension.

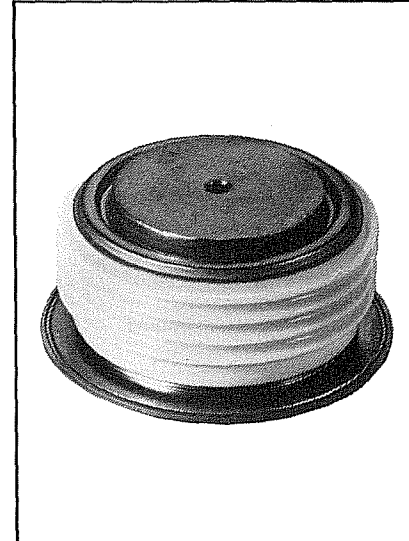

FAST RECOVERY RECTIFIERS

Applications:

- Inverters
- Choppers
- Transmitters
- Free Wheeling

Ordering Information

Type	Voltage		Current		Recovery Time		Leads †	
	Code	V_{RRM} (V)	Code	$I_{F(av)}$ (A)	t_{rr}^* μ sec	Code	Case	Code
R722		400	04	650	1.0	HS	R72	00
		600	06					
		700	07					
		800	08					
		900	09					
		1000	10					
		1100	11					
		1200	12					
		1300	13					
		1400	14					

*Note: Consult factory for additional recovery times.

†Other lead code options available

Example

Obtain optimum device performance for your application by selecting proper Order Code.

Type R722 rated at 650 A average with $V_{RRM} = 1200V$ and recovery time = 1.0 μ sec.

Type	Voltage	Current	t_{rr}	Leads
R 7 2 2	1 2	0 6	HS	0 0

650 A. Avg.
Up to 1400 Volts
1.0 μ s*

Soft-Fast Recovery
RECTIFIER
R722 06



Voltage

Blocking State Maximums ①

Repetitive peak reverse voltage, V V_{RRM}
Non-repetitive transient peak reverse voltage,
 $t \leq 5.0$ m sec V_{RSM}

Symbol

400	600	700	800	900	1000	1100	1200	1300	1400
500	800	900	1000	1100	1200	1300	1400	1500	1600

Reverse current, mA peak I_{RRM}

50

Current

Conducting State Maximums
($T_J = 150^\circ\text{C}$)

Symbol

RMS forward current, A $I_{F(rms)}$	1000
Ave. forward current, A $I_{F(av)}$	650
One-half cycle surge current ②, A I_{FSM}	7500
I^2t for fusing (for times = 8.3 ms) A ² sec I^2t	234,000
Max I^2t of package (t = 8.3 ms) A ² sec I^2t	80 x 10 ⁶
Forward voltage drop at $I_{FM} =$ 1500 A and $T_J = 25^\circ\text{C}$, V V_{FM}	2.05

Switching

($T_J = 25^\circ\text{C}$)

Symbol

Max. Reverse Recover Time $I_{FM} = 1500$, $t_p = 190 \mu$ s $diR/dt = 25A/\mu$ s, $T_C = 25^\circ\text{C}$, μ s trr	1.0
--	-----

Thermal and Mechanical

Symbol

Min., Max. oper. junction temp., $^\circ\text{C}$ T_J	-40 to +150
Min., Max. storage temp., $^\circ\text{C}$ T_{stg}	-40 to +190
Max. mounting torque, in lb. ③ ④	2000-2400
Thermal resistance ⑤ with double sided cooling Junction to case: $^\circ\text{C}/\text{Watt}$ $R_{\theta JC}$.055
Case to sink, lubricated $^\circ\text{C}/\text{Watt}$ $R_{\theta CS}$.020

- ① At maximum T_J
- ② Per JEDEC RS-282, 4.01 F.3.
- ③ Consult recommended mounting procedures.
- ④ For higher voltages contact Westinghouse

Forward Current Vs. Forward Voltage Drop

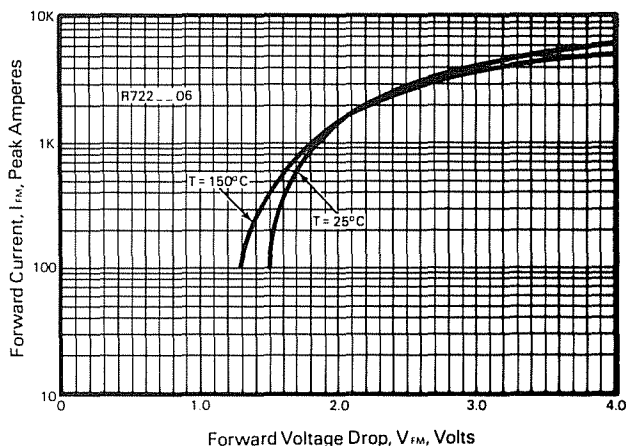

Transient Thermal Impedance Vs. Time

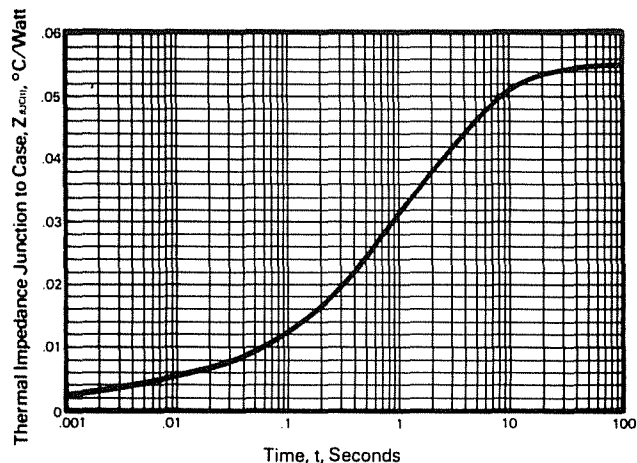

FAST RECOVERY RECTIFIERS



Soft-Fast Recovery RECTIFIER R722 __ 06

650 A. Avg.
Up to 1400 Volts
1.0 μs^*

Reverse Recovery Wave Form

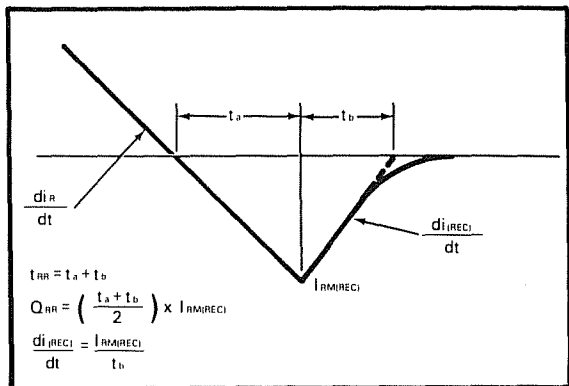

Typical Reverse Recovery Time Vs. Rate of Current Fall

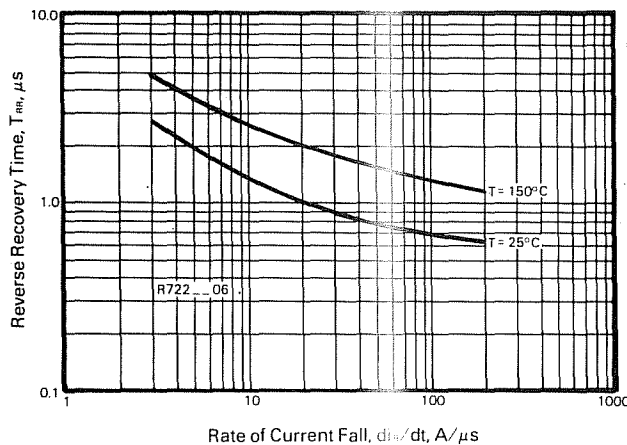

Typical Reverse Recovery Charge Vs. Rate of Current Fall

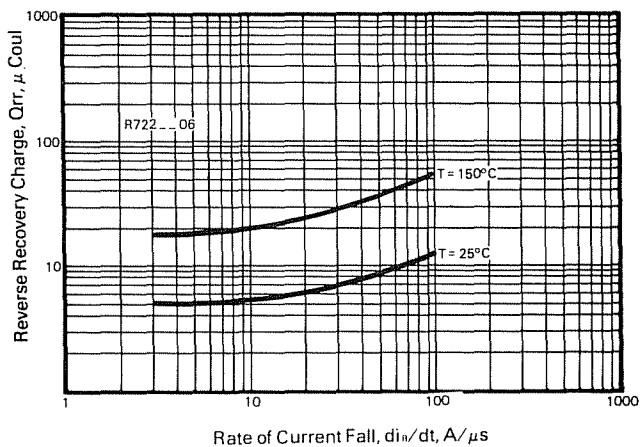

Typical Ratio of Current Recovery to Rate of Current Fall

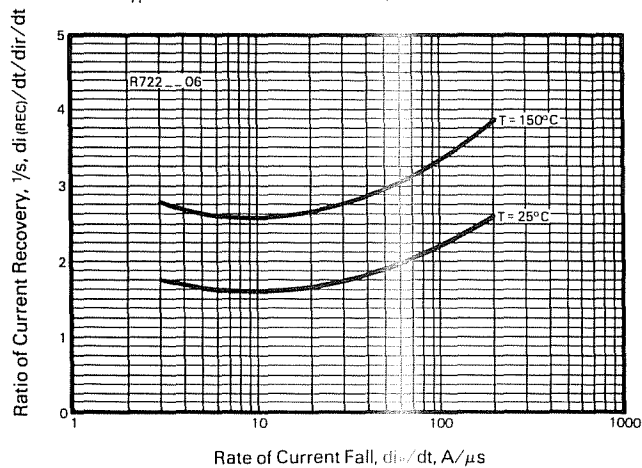

FAST RECOVERY
RECTIFIERS

650 A. Avg.
Up to 1400 Volts
1.0 μs^*

Soft-Fast Recovery
RECTIFIER
R722 __ 06

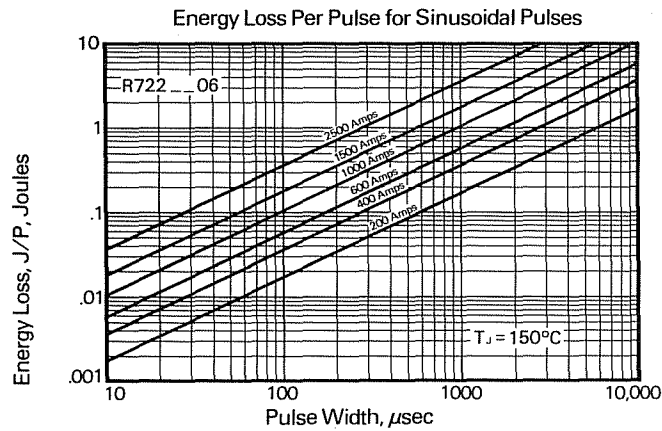

Calculation of Fast Recovery Diodes and Allowable Case Temperature

1. Conduction Losses

$$P_{\text{avg (cond)}} = J/P \times F$$

2. Reverse Recovery Losses (Approximate)

$$P_{\text{avg (sw)}} = \frac{1}{4} \times V_{\text{RX}} \frac{di_{\text{R}}}{dt} \times T_{\text{rr}}^2 \times \left(\frac{1/s}{1 + 1/s} \right)^2 \times F \times 1 \times 10^6$$

3. Maximum Allowable Case Temperature

$$T_{\text{C max}} = T_{\text{J}} - (P_{\text{avg (cond)}} + P_{\text{avg (sw)}}) \times R_{\theta\text{JC}}$$

Where

$P_{\text{avg (cond)}}$ = Forward Conduction Power Loss in Watts

$P_{\text{avg (sw)}}$ = Reverse Recovery Power Loss in Watts

J/P = Energy Loss per pulse in Joules

F = Frequency in Hertz

V_{R} = Steady State Reverse Operating Voltage in Volts

di_{R}/dt = Rate of Decay of Forward Current in Amperes/ μsec

T_{rr} = Reverse Recovery Time in Microseconds

$\frac{1}{\text{"S"}}$ = Ratio of Recovery di/dt $\left(\frac{di_{\text{F}}/dt}{di_{\text{R}}/dt} \right)$

F = Operating Frequency in Hertz

$T_{\text{C max}}$ = Maximum Allowable Case Temperature in $^{\circ}\text{C}$.

T_{J} = Maximum Operating Junction Temperature in $^{\circ}\text{C}$.

$R_{\theta\text{JC}}$ = DC Junction to Case Thermal Impedance in $^{\circ}\text{C}/\text{Watt}$.



Powerex, Inc., 200 Hillis Street, Youngwood, Pennsylvania 15697-1800 (724) 925-7272

Reverse recovery times for
'R' type devices.

TIME, (μ sec)	CODE
Std. Rec.	XX
5.0	AS
4.0	BS
3.0	CS
2.5	DS
2.0	ES
1.5	FS
1.25	GS
1.0	HS
0.9	JS
0.8	KS
0.7	LS
0.6	MS
0.5	PS
0.4	QS
0.3	RS