



# **5600SE Valve**

---

## **Chem Free Iron Filter Operation Manual**



# Performance and Specifications

## Hydrotech Chem Free Iron Filter

Item Number	Model Number	Media cu. ft. (litres)	Iron removal Capacity (ppm)	Pipe Size inches (mm)	Service Flow Rate	Peak Flow Rate	Backwash Flow Rate	Mineral Tank size inches (mm)	Shipping Weight Lbs. (kg)
7624	5600SEM-847CFB	0.75 (21)	22500	3/4 (19)	2.0 (7.6)	4.0 (15)	3.5 (13)	8 x 47 (203 x 1194)	70 (32)
7625	5600SEM-948CFB	1.00 (28)	30000	3/4 (19)	2.5 (9.5)	4.5 (17)	4.0 (15)	9 x 48 (229 x 1219)	90 (41)
7626	5600SEM-1054CFB	1.50 (42)	45000	3/4 (19)	3.0 (11)	5.5 (21)	5.0 (19)	10 x 54 (254 x 1372)	118 (54)

**Caution:** These water conditioners are not intended to be used for treating water that is microbiologically unsafe or of unknown quality without adequate disinfection before or after the system.

- Notes:**
- Operating Temperature Range:** 34° to 110°F (1° to 43°C)
  - Operating Pressure Range:** 20 to 120psi (137 to 827 kPa)
  - Electrical:** 24V/60Hz with a supplied 120V/60Hz Wall Mount CSA Approved Transformer
1. The manufacturer reserves the right to make product improvements which deviate from the specifications and descriptions stated herein without obligation to change previously manufactured products or to note the change.
  2. Peak flow rates are intended for intermittent use only and are for residential application only.



## How Your 5600 SE Water Filter Works

The chemical free iron filter consists of two major components which are:

1. A Mazzei injector, located between the well head and the pressure tank, adds a small amount of air to the iron-laden water whenever the well pump runs.
2. A backwashing-type filter containing special media that causes the iron in the air-injected water to precipitate throughout the filter bed. This process produces an iron removal capacity of up to 30,000 ppm. The media requires no chemical regenerant for oxygen enrichment.

Periodic backwashing of the filter bed flushes the precipitated iron to the drain and readies the filter for use again. The duration of the backwash procedure will vary depending on the iron concentration but generally is 10 minutes total. The frequency of backwashing depends on iron concentration and water usage and ranges from daily to once every 10 days.

In normal operation, the Time of Day display will alternate being viewed with the Volume Remaining display. This display will be in gallons. As treated water is used, the Volume Remaining display will count down from a maximum value to zero or (---). Once this occurs, a regeneration cycle will be initiated at the Set Regeneration Time. Water flow through the valve is indicated by the Flow Dot that will flash in direct relationship to flow rate.

<b>Example</b>	833 Gallons of Treated Water Remaining	Service	•  •	Flow
		Program	P.M.	
	0 Gallons of Treated Water Remaining	Service	•  •	Flow
		Program	P.M.	

In regeneration, the control will display a special regeneration display. In this display, the control will show the current regeneration step number the valve is advancing to or has reached and the time remaining in that step. The step number displayed will flash until the valve has completed driving into this regeneration step position. Once all regeneration steps have been completed, the valve will return to Service and resume normal operation.

<b>Example</b>	Less than 6 minutes remaining in Regen Step #1	Service	•  •	Flow
		Program	P.M.	

Pushing the Extra Cycle Button during a regeneration cycle will immediately advance the valve to the next cycle step position and resume normal step timing.

## Control Operation During Programming

The control will only enter the Program Mode with the valve in Service. While in the Program Mode, the control will continue to operate normally, monitoring water usage and keeping all displays up to date. Control programming is stored in memory permanently, eliminating the need for battery back-up power.

## Control Operation During a Power Failure

During a power failure, all control displays and programming will be stored for use upon power re-application. *The control will retain these values for years, if necessary, without loss.* The control will be fully inoperative and any calls for regeneration will be delayed. The control will, upon power re-application, resume normal operation from the point where it was interrupted. *An indication that a power outage has occurred will be an inaccurate Time of Day display.*

# Before Installation

## Inspection and Handling of Your Chemical Free Iron Filter

Inspect the equipment for any visible shipping damage. If damaged, notify the transportation company and request a damage inspection. Damage to cartons should also be noted.

Handle the filter unit with care. Damage can result if the unit is dropped or set on sharp, uneven projections on the floor. Do not turn the filter unit upside-down.

NOTE: If a severe loss in water pressure is observed when the filter unit is initially placed in service, the filter tank may have been laid on its side during transit. If this occurs, backwash the filter to "reclassify" the bed.

## Iron (Fe)

Iron concentrations as low as 0.3 ppm can cause staining. The iron concentration, the flow rate demand and the consumption rate of the water are used to determine the size of the basic filter system. The higher these factors are, the larger the required system. The chemical free iron filter is capable of filtering out soluble iron (also known as "clear water" or ferrous iron) and precipitated iron (also known as "red water" or ferric iron). There is no apparent upper limit of iron concentration for the chemical free iron filter but special care must be taken when selecting a filter model if your water has a combination of high iron, very low pH and/or manganese levels above 0.5 ppm.

## Manganese (Mn)

The presence of manganese can be bothersome even for a chemical free iron filter. As little as 0.05 ppm of manganese can produce a brownish or black stain. The ability of the chemical free iron filter to remove manganese depends on its concentration and the pH of the water.

## pH

The pH of water measures its acidity or its alkalinity. Water with a pH of less than 7.0 is acidic, more than 7.0 is alkaline and 7.0 is neutral. The lower the pH value is below 7.0, the greater the acidity and higher the pH value is above 7.0, the more alkaline. Acidic water is corrosive to pipes, appliances, etc. A pH of 7.0 or higher facilitates iron removal.

## Tannins (Humic Acid)

Tannins (also known as humic acid), which are present in some water supplies, are the result of decaying vegetable matter. If the tannin concentration is above approximately 0.5 ppm, it will form a sticky coating on the media, thus rendering it incapable of filtering the iron. A chemical free iron filter is not recommended for this situation. If the tannin concentration is less than 0.5 ppm, a chemical free iron filter may be installed.

## Hydrogen Sulfide (H<sub>2</sub>S)

Hydrogen sulfide (often referred to as sulfur) is easily detectable by its objectionable "rotten egg" odor. Sulfur corrodes iron, brass, copper and silver. A chemical free iron filter is not recommended when hydrogen sulfide is the only water problem, although it is capable of removing sulfur in concentrations of up to 3 ppm. Whenever hydrogen sulfide is present, backwashing must be performed at more frequent intervals and the pumping system must include a standard air-to-water pressure tank with an air relief valve.

## Checking Your Water Pressure and Pumping Rate

Two water system conditions must be checked carefully to avoid unsatisfactory operation or equipment damage,

1. Minimum water pressure required at the filter tank inlet is 20 psi. ***If pressure is over 100 psi, a pressure reducing valve must be installed in the water supply line ahead of the Mazzei injector.*** NOTE: If you have a municipal or community water supply and daytime water pressure is 85 psi or more, nighttime pressure may exceed 100 psi. Call your local water department or plant operator to obtain pressure readings. If you have a private well, the gauge on the pressure tank will indicate the high and low system pressure. Record your water pressure data below:

Low \_\_\_\_\_ psi      High \_\_\_\_\_ psi

2. The pumping rate of your well pump must be at least 5 gallons per minute (gpm) for satisfactory operation of the Mazzei injector. In addition, the pumping rate must equal the backwash flow rate of your filter. To measure the pumping rate of your pump, follow these instructions:
  - a. Make certain no water is being drawn. Open spigot nearest pressure tank. When pump starts, close spigot and measure time (in seconds) to refill pressure tank (when pump shuts off). This figure represents ***cycle time***.
  - b. With the pressure tank full, draw water into a container of known volume and measure the number of gallons drawn until the pump starts again. This is ***draw down***.
  - c. Divide the draw down figure by the cycle time and multiply the result by 60 to arrive at the pumping rate in gallons per minute (gpm).

$$\text{DRAW DOWN} \div \text{CYCLE TIME} \times 60 = \text{PUMPING RATE}$$

## Locate Water Conditioning Equipment Correctly

Select the location of your filter tank with care. Various conditions which contribute to proper location are as follows:

1. Locate as close as possible to the water supply source.
2. Locate as close as possible to a floor or laundry tub drain.
3. Locate in correct relationship to other water conditioning equipment (see Typical Installations, Page 4).
4. Filter and softeners should be located in the supply line before the water heater. Temperatures above 110° F (43°C) will damage the equipment and void the warranty.
5. Do not install a filter or softener in a location where freezing temperatures occur. Freezing may cause permanent damage to the equipment and void the warranty.
6. Allow sufficient space around the unit for easy servicing.
7. If your water source is a community or public water supply or if you wish to bypass water used for a geothermal heat pump, lawn sprinklers, out buildings or other high demand applications, refer to installation instructions.

## The Importance of Your Pressure Tank

The pressure tank found on private well systems becomes an integral part of the filter system by providing necessary mixing and "contact time" to the "air-injected" water. While the iron filter will perform better on a standard air-to-water pressure tank, it will perform satisfactorily on a captive air (bladder) pressure tank. The bladder tank requires more careful adjustment of the Mazzei injector and careful location of the air relief valve.

If cycle time on the pumping system is less than 30 seconds and under severe operating conditions (low pH, high iron, manganese and small concentrations of hydrogen sulfide), a standard air-to-water pressure tank with an air relief valve must be used (if a bladder tank is already in place, do not remove it, install the air-to-water pressure tank between the Mazzei injector and the bladder tank).

NOTE: If your pressure tank (or any part of your water system) is not functioning properly, corrective action must be taken before installation of your chemical free iron filter.

## Facts to Remember When Planning Your Installation

1. All installation procedures must conform to local and state plumbing codes.
2. All water must pass through the Mazzei injector, pressure tank and the filter or refer to the special instructions for a split-stream installation. (System may malfunction if this instruction is ignored.)
3. If water for other devices/activities, such as lawn sprinkling, a swimming pool, geothermal heating/ cooling is to be treated by the filter, a larger model filter must be selected to accommodate the higher flow rate demands of these items. The pumping rate of the well pump must be sufficient to accommodate these items plus the backwashing requirement of the filter. Consult your dealer for alternative instructions if the pumping rate is insufficient.
4. Remember that the filter inlet is attached to the pipe that supplies water and the outlet is the line that runs toward the water heater.
5. Before commencing installation, it is advisable to study the existing piping system and to determine the size, number and type of fittings required. Typical system schematics shown in these instructions will be of assistance.

**NOTE:** If the plumbing system is used as the ground leg of the electric supply, continuity should be maintained by installing ground straps around any non-conductive plastic piping used in the installation.

## Installation Instructions

**All government codes and regulations governing the installation of these devices must be observed.**

**CAUTION:** If the ground from the electrical panel or breaker box to the water meter or underground copper pipe is tied to the copper water lines and these lines are cut during installation of the Noryl bypass valve and/or poly pipe, an approved grounding strap must be used between the two lines that have been cut in order to maintain continuity. The length of the grounding strap will depend upon the number of units being installed and/or the amount of copper pipe being replaced with poly. See Figure 1.

In all cases where metal pipe was originally used and is later interrupted by poly pipe or the Noryl bypass valve as in Figure 1 or by physical separation as in Figure 2, an approved ground clamp with no less than #6 copper conductor must be used for continuity, to maintain proper metallic pipe bonding.

Check your local electrical code for the correct clamp and cable size.

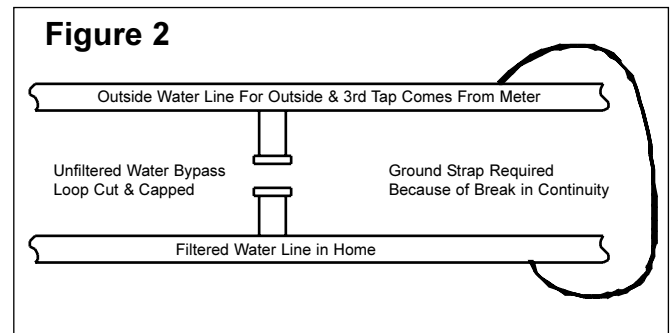
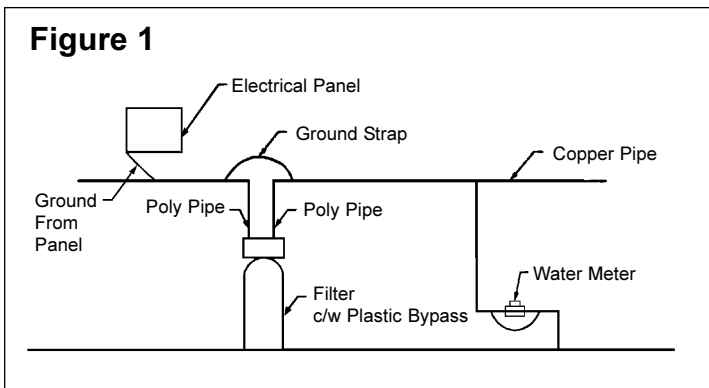

# Typical Installations

Proper installation sequence of water conditioning equipment is very important. Refer to the following diagrams for your particular water supply.

**NOTE:** Before starting installation, read Page 9, Plumbing System Clean-Up, for instructions on some procedures that may need to be performed first.

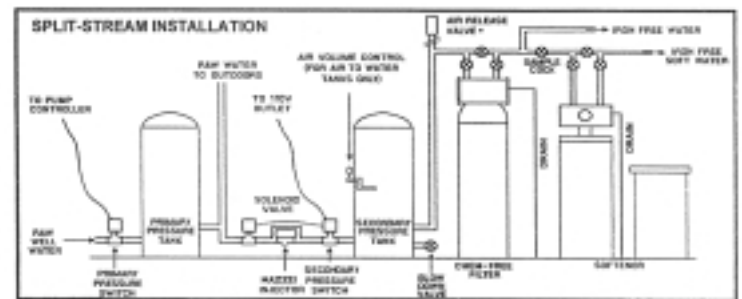
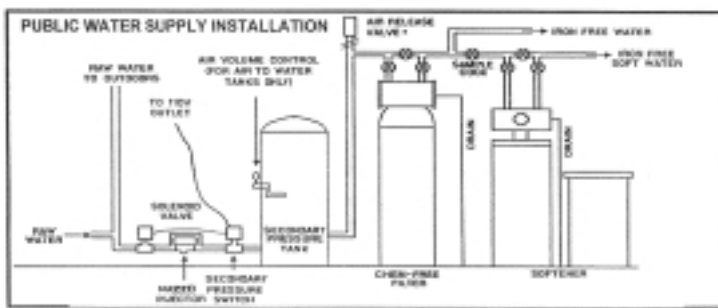
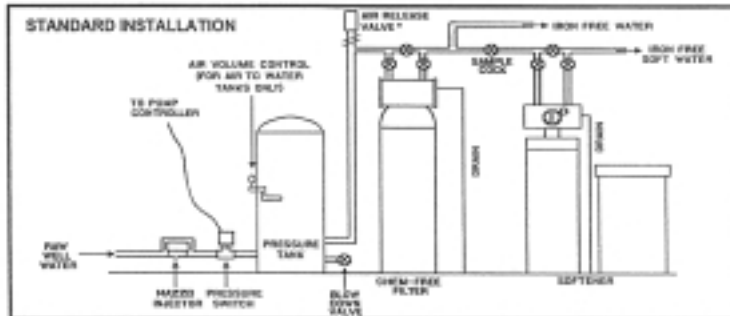

1. Shut off all water at main supply. On a private well system, turn off power to pump and drain pressure tank. Make certain pressure is relieved from complete system by opening nearest faucet to drain the system. Shut off fuel supply to water heater.
2. Cut main supply line as required to fit Mazzei injector in plumbing between well pump and pressure tank (Mazzei injector may installed in a vertical or horizontal position). Be certain direction of flow arrow on the Mazzei injector points toward pressure tank and pressure control switch is located on the pressure tank side of the Mazzei injector (rapid cycling of the pump may occur if pressure switch is located on the well side). If check valves are used, they should be installed before the Mazzei injector, not between the Mazzei injector and the pressure tank.

**NOTE:** It is advisable to install the Mazzei injector with the unions at both ends to facilitate removal and inspection. On badly scaled older pumping systems, it may be advantageous to install an optional "y" strainer ahead of the Mazzei injector to prevent plugging the injector nozzle with scale.

3. Cut the main supply line as required to fit plumbing to the control valve with bypass.
4. Solder or solvent weld plumbing. Do not apply heat to any fitting connected to the control valve as damage may result to the internal parts. Check to be certain water supply pipe is connected to the control valve inlet fitting and pipe connected to control valve outlet fitting is in direction of house service.

**NOTE:** If the installation is to be split-streamed prior to the filter tank or is a public water supply installation, refer to special instructions.

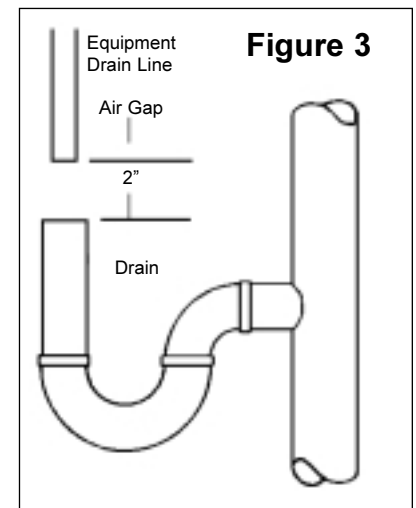

5. Pull out drain line flow control assembly from valve body. Unscrew drain line fitting elbow from drain line flow control. Apply Teflon tape to threads. Reassemble to valve body, making certain drain line flow control assembly is fully inserted into valve body. Attach 1/2 in diameter drain line to drain elbow.
6. Position drain hose over drain and secure firmly. To prevent back-siphoning of sewer water, provide an air gap of at least 2 inches or 2 pipe diameters between the end of the drain hose and the drain. Do not raise drain hose more than 10 ft. above floor.
7. Make sure the bypass valve is in the service position.
8. Plug the 24-volt transformer into a 120 VAC 60 Hz outlet. This valve has four positions: 1) Backwash 2) Brine/Rinse (not used) 3) Rapid Rinse and 4) Brine Refill (not used). When the valve is in the Service position, the *extra cycle* button (far left button as shown on Figure 5) must be pressed and held for 5 seconds before it activates. Press and hold the *extra cycle* button for 5 seconds to advance the valve to the "1" Backwash position. Slowly turn on the water supply and allow the unit to backwash until the air purges out of the tank and clears the system.

NOTE: During the initial backwashings, a small amount of fine brownish media may be observed in the drain water. This is normal and beneficial for the efficient operation of your filter system.

9. Press the extra cycle button to advance the valve back into the service position indicated by the red dot in upper left corner of the display.

10. To adjust the Mazzei injector: (Figure 4)

- a. Make sure the liter meter is in a vertical position.
- b. Adjust air suction by opening and closing the bypass valve.
- c. Setting is correct when the liter meter shows 1/2 L/M of air entering the injector.

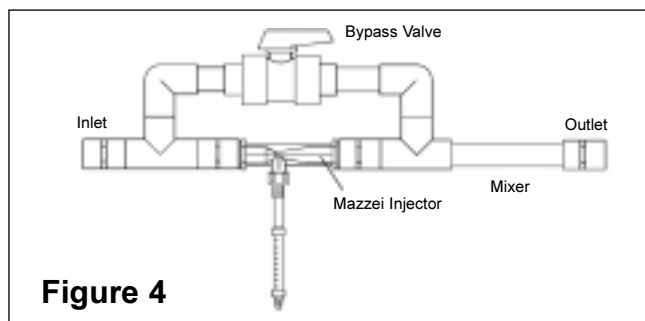

**Figure 4**

11. Make certain bypass is closed and inlet and outlet valves are fully opened. Check for leaks.

12. Set the time of day and backwash frequency.

NOTE: Due to the nature of the media, the filter sometimes takes several days after start-up to completely remove the iron. Do not become alarmed if this occurs.

## Operating Instructions

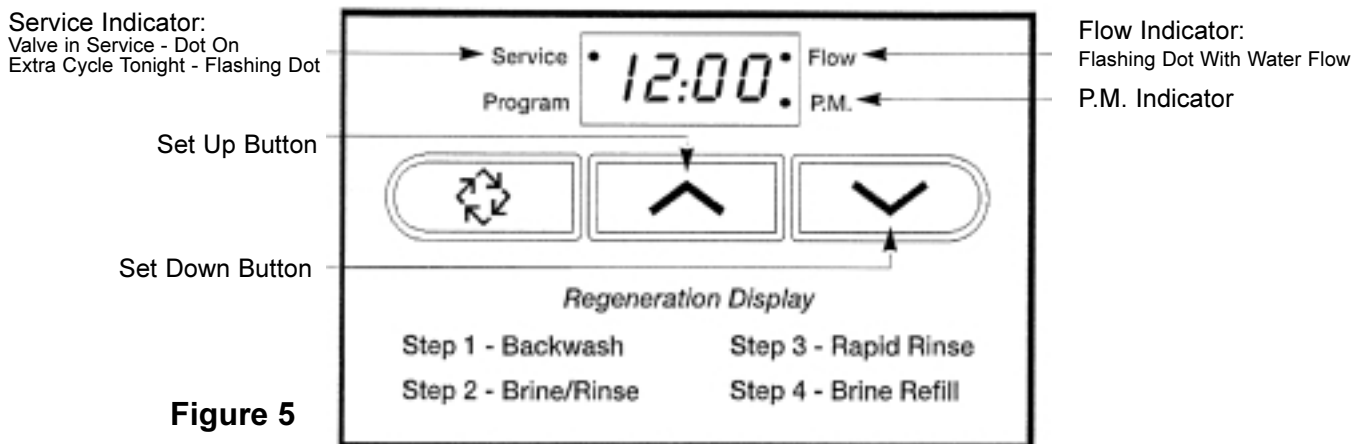

**Figure 5**

The valve has been pre-programmed with factory settings as follows:

### Regeneration Cycle Step Programming

1. Backwash .....6 minutes
2. Brine Rinse .....0 minutes (not used)
3. Rapid Rinse .....4 minutes
4. Brine Refill .....0 minutes (not used)



# Operating Instructions

Whenever the valve is in Service the current time of day can be set, the control programmed, or an extra regeneration initiated at any time.

## 1. Set Time Of Day

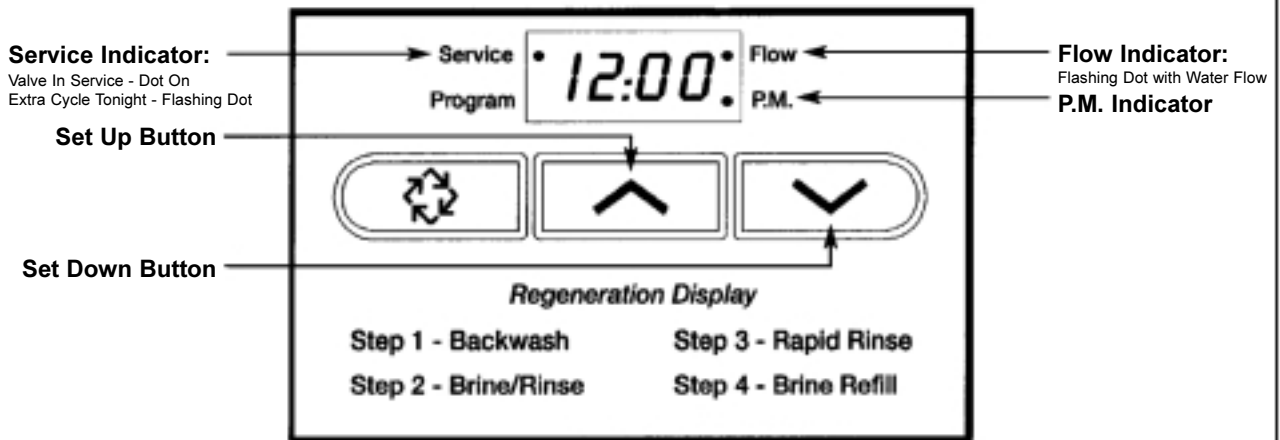

Push either the Up or Down Set Button once to adjust Time of Day Display by one digit.  
Push and hold either Up or Down Set Button to adjust Time of Day Display by several digits.

## 2. Enter Control Programming Mode

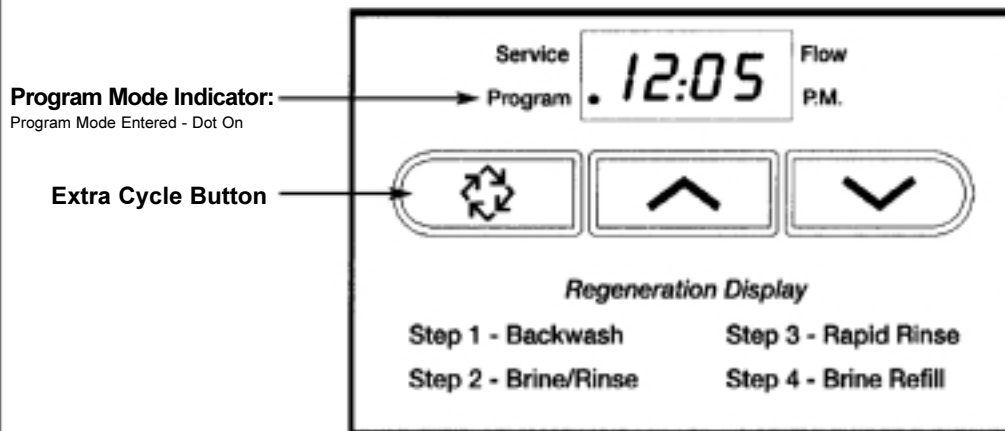

1. Push and hold for 5 seconds *both* the Up and Down Set Buttons to enter Programming Mode.
2. Push the *Extra Cycle Button* once per display until all have been viewed and this mode is exited and normal operation is resumed.

# 3. Set Control Programming

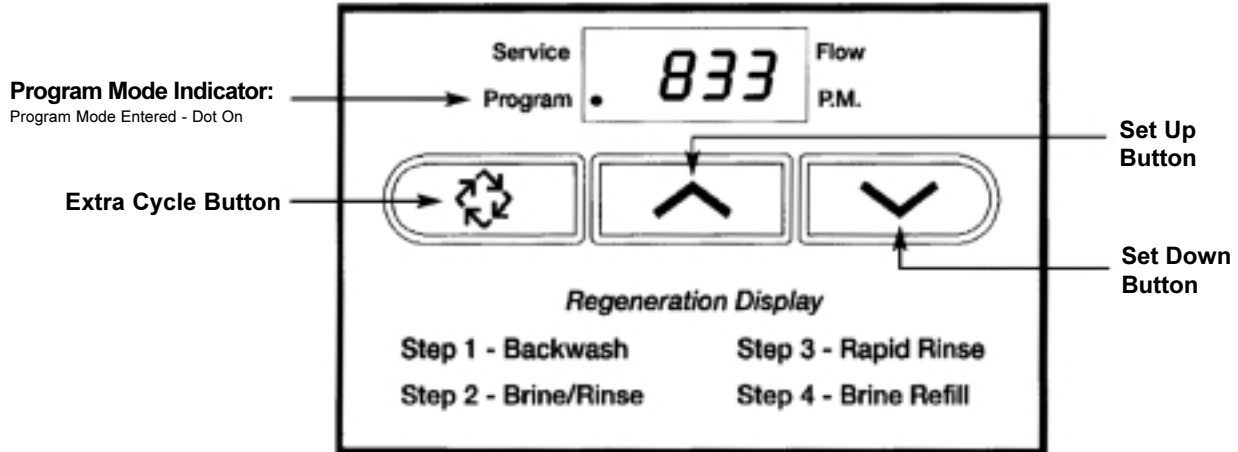

1. The first option setting display that appears in the Program Mode is Treated Water Capacity. Using the Set Up or Down Buttons, set the amount of treated water that can flow through the unit before a regeneration is required. For Example:

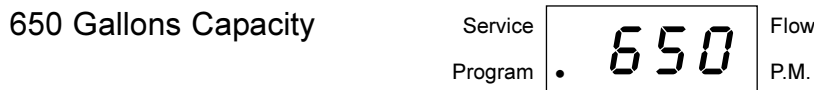

2. Push the Extra Cycle Button. The second option setting display that appears is Regeneration Time. Using the Set Up or Down Buttons, set the desired time of day when a regeneration can occur, is required. For Example:

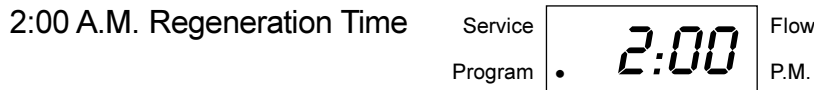

3. Push the Extra Cycle Button. The third option setting display that appears is Regeneration Day Override. Using the Set Up or Down Buttons, set the maximum number of days before a regeneration cycle must occur. For Example:



***This is an option only. Please do not adjust before consulting an authorized dealer.***

## Special Instructions for Split-Stream and Public Water Supply Installations

For a split-stream installation, a secondary pressure tank must be installed as shown in the split-stream installation diagram (Page 4). On a public water supply installation, a pressure tank must be installed as shown in the public water supply installation diagram (Page 4). It is recommended in both applications to use a standard air-to-water pressure tank with an air relief valve of a capacity that would normally be installed if the water system were a standard private well. Also note that in both applications a normally closed solenoid valve is required. Follow the standard installation instructions above with the following additions and modifications:

1. Install the pressure tank as indicated by the appropriate diagram.
2. Install a normally closed solenoid valve after the water meter and after a line split for untreated water (if there is one).
3. On both types of installation, install the Mazzei injector between the pressure tank (secondary pressure tank on split-stream installations) and normally closed solenoid valve.
4. Install the pressure switch after the Mazzei injector and wire it to the solenoid valve (secondary pressure switch on split-stream installations). Set high pressure on pressure switch (which controls opening and closing of the solenoid valve) 2 to 3 psi lower than low pressure on primary pressure switch. EXAMPLE: If primary pressure switch is set at 40-60 psi, set the secondary pressure switch at 18 to 38 psi.
5. For public water supply installations, contact your local water department or plant operator and ask what the normal low system pressure is. Set high pressure on pressure switch 2 to 3 psi lower than this figure.

NOTE: Failure to set the pressure switch as described above will not allow proper closing of the solenoid valve during periods of low system pressure.

## Plumbing System Clean-Up

The following procedures are guidelines only but have proven successful in most instances. Under no circumstances should any procedure outlined below be followed if contrary to the appliance manufacturer's instructions. Should there be any questions concerning the advisability of performing a procedure, it is strongly recommended the manufacturer's authorized service outlet be consulted prior to performing the procedure.

The plumbing system and water using appliances that have been exposed, even for a short time, to iron-fouled water need to be cleaned of the precipitated iron that has collected in them or iron bleed (staining) will continue to be a problem.

Depending on the amount of iron in the water and the length of time the water system has been exposed to iron fouling, select from the following procedures those that apply to the type of system and appliances that need to be cleaned to assure iron-free water at all points of use.

### Softener

It isn't uncommon that the softener was installed in an effort to remove ferrous (clear water) iron from the water supply. Typically a softener will remove some ferrous iron until the resin bed becomes fouled to the extent that it will lose both hardness removal capacity and the limited capacity for iron removal. This is the condition to expect the softener to be in when planning a system clean-up.

Prior to closing the main supply valve or turning power off to a private well system and preparatory to installing the filter system, do the following:

1. Disconnect the brine draw line from the brine cabinet and place the loose end into a five gallon plastic pail filled with a solution of warm water and 4 oz. of resin mineral cleaner.
2. Advance the control timer to the brine draw position (refer to instructions provided with your softener). Allow all the warm mineral cleaner solution to be drawn into the mineral bed.
3. Then immediately close the main water supply valve or turn the power off to the pump and proceed with the filter installation. During the time required to install the filter system, the iron-fouled softener resin will be chemically cleaned.
4. After the filter installation is completed and final adjustments have been made, with the water turned on and the brine draw tube reconnected, reposition the timer on the softener to the backwash position. Allow the timer to perform an automatic regeneration cycle. During backwash of the softener, all iron cleaned from the resin will be washed down the drain. It is advisable, after chemically cleaning the softener, to regenerate the system twice to fully restore capacity lost due to iron-fouling.

## Water Heater

If the water heater has been exposed to both iron and hardness for a long period of time, replacement of the heater tank may be the only practical solution to prevent continued staining originating from this source.

After completing the installation of the chemical free iron filter, clean the water heater by following these instructions:

1. Shut off the energy supply to the water heater and close the heater inlet water valve.
2. Drain hot water tank completely. Open inlet water valve, allowing heater tank to be refilled with iron-free water. Continue flushing until the water runs clear to the drain.
3. If, after approximately 30 minutes of flushing, water does not clear, terminate the flushing operation. Refill hot water heater with water and pour approximately 1/2 gallon of household bleach into the top of the heater tank. Allow bleach solution to stand in tank for 20 to 30 minutes. Flush the tank again until water is clear at the drain. Turn energy supply on.

NOTE: If water does not clear in approximately 10 minutes, water heater should probably be replaced.

## Backwashing Instructions

### To Calculate Backwash Frequency

To ensure adequate reserve capacity and prevent loss of water pressure between backwashes the figure of 15,000 not the full 30,000 ppm capacity is used to calculate backwash frequency. Determine your backwash frequency as follows:

Estimate the daily iron removal requirements using the following calculation:

Number of people in the family  
x 75 gallons of water per person  
+ Number of gallons for special use (if applicable)  
= Number of gallons of water required per day  
x Iron concentration - ppm  
= Daily iron removal requirement

Establish backwash frequency using daily iron removal requirements to complete the following calculation:

15,000 ppm iron removal capacity  
÷ Daily iron removal requirement - ppm  
= Number of backwashes required in a 10 day schedule

Example: You have 4 people in the family, 8 ppm of iron and a swimming pool requiring 46 gallons of water per day.

4	People in the family
<u>x 75</u>	Gallons of water per person
300	Gallons of water for family
<u>+ 46</u>	Gallons of water for the pool
346	Gallons of water required per day
<u>x 8</u>	Iron concentration - ppm
2,768	Daily iron removal requirement - ppm
15,000	Iron removal capacity - ppm
<u>÷ 2,768</u>	Daily iron removal requirement - ppm
5.4	Backwash frequency - days

The calculation indicates the need to backwash every 5.4 days. The control should be set to backwash every 5th day.

## Dishwasher

Consult your owner's handbook and follow the manufacturer's instructions.

## Toilet Flush Tanks

Prior to commencing installation of the filter system, pour 4 to 6 oz. of resin mineral cleaner Iron-Out or inhibited muriatic acid into flush tanks and bowls and let stand. When installation is completed, flush toilets several times with iron-free water. If iron deposits or stains remain, repeat procedure until clear.

## Water Pressure

Your chemical free iron filter system is designed to operate under normal water pressures from 20 psi to 100 psi.

## Automatic Bypass

Your filter is factory set to backwash at 11:00 p.m. during a period of little or no water use. The backwash cycle lasts approximately 15 minutes, after which filtered water service is restored. While backwashing is taking place, raw water automatically bypasses the filter if required. If possible, avoid using water during backwashing to prevent iron-laden water from entering your household plumbing system.

**(Installation Tip: The 5600SE Filter should not be allowed to regenerate at the same time as any other water treatment units. If adjustment is required, consult programming chart to adjust default regeneration time.)**

## New Sounds

You will notice new sounds such as the hum of the timer as your filter operates. During backwashing it will not be uncommon to hear water running to the drain.

## Manual Bypass

In case of an emergency you can isolate your water filter from the water supply using the bypass valve located at the back of the control.

In normal operation the bypass is open with the ON/OFF knobs in line with the INLET and OUTLET pipes. To isolate the filter, simply rotate the knobs clockwise (as indicated by the word BYPASS and arrow) until they lock.

You can use your water related fixtures and appliances as the water supply is bypassing the filter. However, the water you use will be untreated.

To resume filtered water service, open the bypass valve by rotating the knobs counter-clockwise.

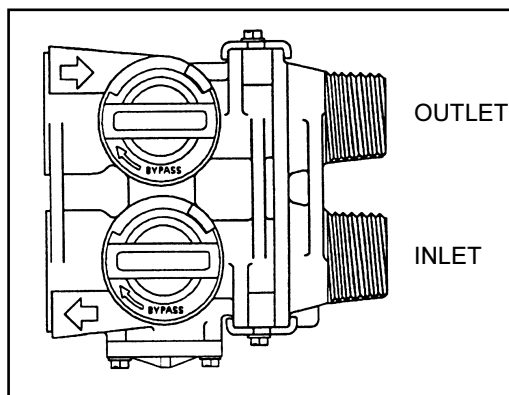

## Manual Regeneration Cycle

If you run out of filtered water because of inadequate regeneration frequency, inadequate reserve capacity, power failure or unusually high water usage, you can initiate a manual regeneration simply by pressing the extra cycle button. The filter will now automatically complete a regeneration cycle and return to service. If possible, avoid water use during the regeneration cycle.

Once you have set your filter and you experience frequent loss of water pressure, you may have to increase the frequency of regeneration by resetting the gallons between regeneration.

# Maintenance Instructions

Maintenance of your new water filter requires very little time or effort but it is essential. Regular maintenance will ensure many years of efficient and trouble-free operation.

## Care of All Water Filters

To retain the attractive appearance of your new water filter, clean occasionally with a mild soap solution. DO NOT use abrasive cleaners, ammonia or solvents. Never subject your filter to freezing.

## Trouble Shooting Guide

PROBLEM	CAUSE	CORRECTION
1. Water clear when drawn; turns red upon standing (stain producing)	<p>A. Insufficient air drawn by the Mazzei injector</p> <p>B. Bypass open or leaking</p> <p>C. Filter bed overloaded with precipitated iron due to insufficient backwash</p> <p>D. Presence of manganese or tannins</p> <p>E. Flow rate excessive for model</p> <p>F. Check valve located between Mazzei injector and pressure tank, disrupting water flow.</p> <p>G. Pumping cycle too short</p>	<p>A. Check Mazzei injector adjustment. If unable to adjust for long enough draw, check pumping rate.</p> <p>B. Close bypass and/or repair as necessary</p> <p>C. Increase backwash frequency. Upon correction of problem, manually backwash until backwash water starts to clear. In more severe iron-fouling cases, bed may need chemical cleaning - contact dealer.</p> <p>D. Recheck water analysis</p> <p>E. Reread "Facts to Remember While Planning Your Installation" Page 3</p> <p>F. Relocate check valve.</p> <p>G. Lengthen pump cycle time.</p>
2. Water red when drawn from tap	<p>A. Filter bed overloaded with precipitated iron due to insufficient backwash flow rate</p> <p>B. Filter bed overloaded with precipitated iron due to insufficient backwash</p> <p>C. Mazzei injector drawing too much air causing early precipitation of iron</p> <p>D. Mazzei injector installed too far from pressure tank or pressure tank located too far from filter tank</p> <p>E. Solenoid valve malfunction or inadequate supply system pressure/flow rate</p>	<p>A. a. Recheck well pumping rate and repair or replace as required</p> <p>b. Check for obstructions or kink in drain line</p> <p>c. For improper drain line flow controller, see specs.</p> <p>Upon correction of this problem, if manually backwashing does not clear bed of iron, filter bed may need chemical cleaning - contact dealer.</p> <p>B. Increase backwash frequency. Upon correction of problem, manually backwash until backwash water starts to clear. In more severe iron-fouling cases, bed may need chemical cleaning - contact dealer.</p> <p>C. Reduce Mazzei injector air draw</p> <p>D. Contact dealer for proper location of Mazzei injector and pressure tank</p> <p>E. Replace solenoid valve, check specs for proper pressure/flow rates</p>
3. Excessive pressure loss through filter	<p>A. Filter bed overloaded with precipitated iron.</p> <p>B. Control inlet/outlet valve(s) not fully open</p> <p>C. Sand, silt or mud collecting in filter bed</p> <p>D. Filter bed not properly classified</p>	<p>A. See problem above</p> <p>B. Open valves</p> <p>C. Check well for these conditions</p> <p>D. Manually backwash to reclassify</p>
4. Milky or bubbly water (appears to contain small bubbles)	<p>A. Excess Mazzei injector air draw</p> <p>B. Excess gases in water (carbon dioxide, hydrogen sulfide, methane)</p>	<p>A. Check adjustment for duration of draw in excess of 1/3 pumping cycle.</p> <p>B. May require draining of water system or installation of air relief control - contact dealer.</p>



# **GUARANTEE**

**HYDROTECH** guarantees that your new water conditioner is built of quality material and workmanship. When properly installed and maintained, it will give years of trouble-free service.

## **FIVE YEAR COMPLETE PARTS GUARANTEE**

**HYDROTECH** will replace any part which fails within 60 months from date of manufacture, provided the failure is due to a defect in material or workmanship. The only exception shall be when proof of purchase or installation is provided and then the warranty period shall be from the date thereof.

## **TEN YEAR GUARANTEE ON MINERAL TANKS**

**HYDROTECH** will provide a replacement mineral tank to any original equipment purchaser in possession of a tank that fails within 120 months, provided that the water conditioner is at all times operated in accordance with specifications and not subject to freezing or exposure to direct sunlight.

## **GENERAL PROVISIONS**

**HYDROTECH** assumes no responsibility for consequential damage as a result of escaped water from the water filter; labor or expense incurred as a result of a defect or for failure to meet the terms of these guarantees because of circumstances beyond its control.

**WaterGroup Inc.**  
Fridley, Minnesota  
Sun Valley, California  
1-800-354-7867

**WaterGroup Companies Inc.**  
Regina, Saskatchewan  
Cambridge, Ontario  
1-877-299-5999

[www.hydrotechwater.com](http://www.hydrotechwater.com)

Printed in Canada