



De-Icing Ponds



Transformer Pad (Before / After)

Lange Containment Systems, Inc.
5150 Race Court
Denver, CO 80216
Phone: 303-446-8644
Fax: 303-446-8798
Email: LinerGeeks@LangeContainment.com



Contents

Introduction

<u>Letter from the President</u>	<u>3</u>
<u>About Lange Containment</u>	<u>4</u>

Project Profiles

<u>Dip Creek Ranch</u>	<u>5</u>
<u>National Cooperative Refinery Association</u>	<u>6</u>
<u>Salt Lake City International Airport</u>	<u>7</u>
<u>Burlington Northern</u>	<u>8</u>
<u>Palau Semakau Landfill</u>	<u>9</u>

Complete Solutions

<u>EZ Containment System</u>	<u>10</u>
------------------------------	-----------

Geomembrane Specifications

<u>PVC</u>	<u>11</u>
<u>Hypalon</u>	<u>12</u>
<u>XR-5</u>	<u>13</u>
<u>Polypropylene</u>	<u>14</u>
<u>Geomembrane Chemical Resistance</u>	<u>15</u>

Typical Arrangement Details

<u>Mechanical Attachment</u>	<u>16</u>
<u>Pipe Boot</u>	<u>17</u>
<u>Air / Gas Vent</u>	<u>18</u>
<u>Palletizing & Unfolding</u>	<u>19</u>



Greetings,

I would like to take this opportunity to introduce you to our company.

Lange Containment Systems, Inc. (LCSI) is a premier fabricator of custom geosynthetic membrane products. We specialize in large panels, custom shapes and a full line of accessories. We utilize the highest quality materials including PVC, Hypalon, XR-5, Polypropylene, Urethanes and a variety of coated fabrics.

Our management team has over 50 years experience in all facets of the business and in all corners of the globe. We have had extensive experience with secondary containment of fuels and chemicals. Our applications range from temporary liners below a skid-mounted diesel tank to complex tank farms. At your direction we can provide all the components to do a containment kit and also offer the field installation services of a technician or complete crew to install the system.

LCSI is committed to providing the highest quality products, with the service and flexibility that sets the standard for our industry. This means that each bid, job, and person will get the quality individual attention of our team that is deserved. Our service will not be compromised.

With that said, please take your time reviewing our brochure and work. We welcome your calls and questions, and look forward to doing business with you in the future.

Sincerely,



Stuart Lange, President
Lange Containment Systems, Inc.



About LCSI

Centrally located in Denver Colorado, Lange Containment Systems Inc (LSCI) is a fabricator and installer of geomembranes and other geosynthetics. LSCI was founded in 1994 and has since fabricated and installed in excess of 100,000,000 F² of liner systems all over the world, including Antarctica.

LCSI received an [Industrial Fabrics Association International](#) (IFAI) award of Excellence for the Salt Lake City International Airport deicing fluid storage and recycling ponds.

Health & Safety Policy:

At Lange Containment Safety is our number one priority for our staff, our clients and the people with whom we interact. Our approach is based on individual behavior and we apply this behaviour-based safety approach to all aspects of our work.

Environmental Policy:

Lange Containment is committed to improving the environment through our own internal initiatives. Our key environmental objectives include:

- Conduct our business in an environmentally responsible manner;
- Minimise environmental risks by employing safe operating procedures; and
- Limiting our impact on the environment by reducing office waste and waste generated by our operations.



Locate LCSI

We are conveniently located the heart of Denver's Industrial center. Click on Map for further details.

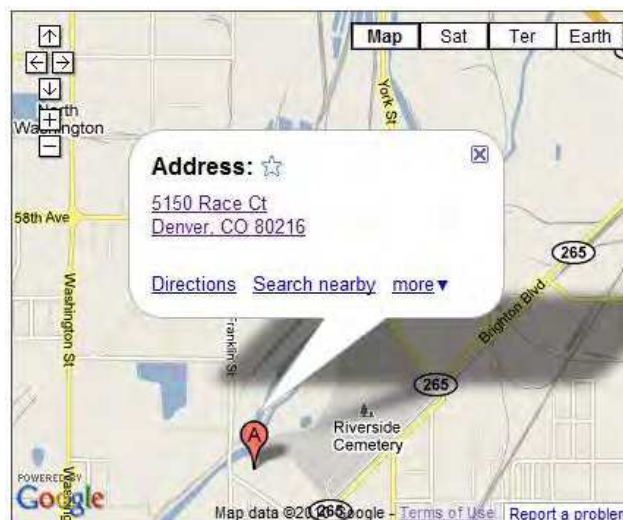



Project Profile

Dip Creek Ranch at Sun Valley, Idaho

The task of transforming a 20 acre sheep pasture into an exclusive million dollar residential development is the type of challenging project Doug McCoy Construction of Twin Falls, Idaho aggressively pursues. However, when the design called for an aquaculture system of membrane lined lakes and stream beds capable of growing trophy trout, the company knew it would need a quality sub-contractor to supply and install the 30 mil PVC liner. After a thorough investigation of a number of lining companies, Lange Containment Systems was chosen for the project.

Lange Containment Systems began the project by creating a panel layout that minimized field seaming and waste materials. Next, the 30 mil PVC product was fabricated into large panels in the LCS factory using state of the art Radio Frequency (dielectric) welding equipment. Once the product was delivered to the site, LCS personnel quickly followed on a coordinated schedule with the contractor. This allowed the installation crew to arrive on site and begin installation as soon as the substrate had been prepared. The installation crew's high productivity maximized the on-site time and provided for an efficient and worry free installation.

After the liner was installed, the crew from Doug McCoy Construction placed the required cover materials on the liner. After filling the lakes and landscaping the shores, the development is ready for home construction. Regardless of whether you need industrial containment or water features for trophy fish, Lange Containment Systems can meet your geomembrane liner needs.



Project Profile

National Cooperative Refinery Association Brine Ponds #1 and #2 Conway, KS

The oil and gas fields of southwest Kansas provide high quality petrochemical materials. The underlying natural salt domes provide large storage areas. Salt water is pumped in and out of the salt caverns to adjust for the fluctuating product inventory. When this super saturated brine is pumped out it must be securely stored for future use and the protection of the surrounding farm lands.

Lange Containment provided the 30 mil PVC and 36 mil Hypalon for Brine Pond lining systems at the National Cooperative Refinery Association facility in Conway, Kansas. The 36 mil Hypalon acts as the primary liner. This liner contains the brine material and prevents contamination of the soils and ground water. In the occurrence that the Hypalon liner is breached, the 30 mil PVC acts as a secondary liner. A leak detection system, positioned between the primary and secondary liners, notifies the operators and they can cease the use of the pond until repairs can be made.



Project Profile

SALT LAKE CITY INTERNATIONAL AIRPORT DE-ICING STORAGE PONDS

In preparation for the onslaught of visitors attending the 2002 Winter Olympics, the Salt Lake City Airport was humming with activity. One of the main infrastructure improvements was the implementation of a collection, storage and recycling system for aircraft de-icing fluids. Ethylene Glycol, the major component of de-icing fluid can be problematic as a run-off pollutant. In addition, when stored in open ponds odor control and waterfowl kill are key issues. The airport and their consulting engineer, CH2M Hill, were looking for a design/build plan for three 2½ acre impoundments.

Lange Containment Systems' design, utilizing XR-5 8130 from Seaman Corporation, was approved. The floating cover design incorporates a rain water collection system with an active pumping and discharge piping system as well as maintenance walkways and access hatches. Utilizing large prefabricated panels and shop customized components, Lange Containment Systems completed the lining and floating cover system installation on schedule and without delays. Lange Containment was able to meet the challenge of providing a low profile, economical storage system that will protect the surrounding eco-systems for years to come.

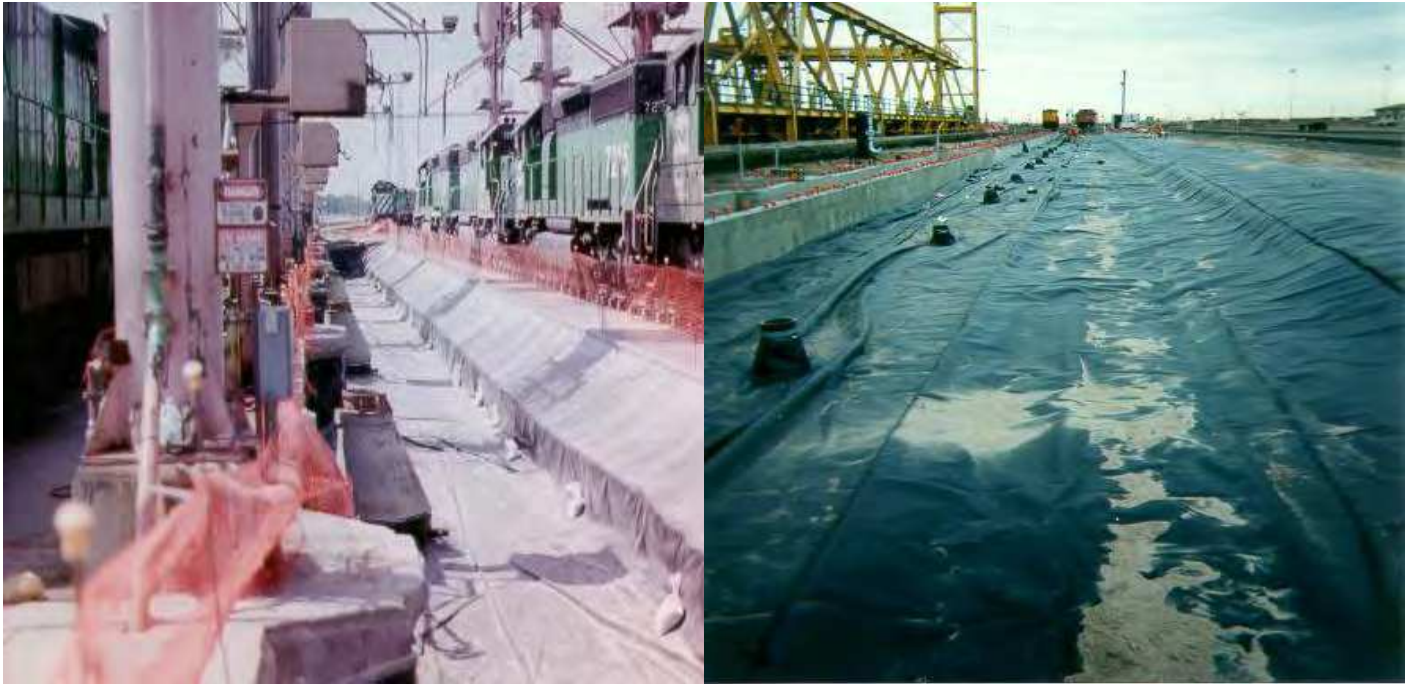

Project Profile Burlington Northern Maintenance Facility Alliance, Nebraska

Lange Containment Systems provides XR-5 membrane to railroad fueling and maintenance facilities for secondary containment of diesel fuel and other materials required to keep the locomotives in working order. The XR-5 membrane is the preferred choice of the railroad industry because of its high resistance to most hydrocarbons as well as other chemicals. In addition, the flexibility of the XR-5 membrane provides the adaptability to be used in existing facility retro-fits, as well as with new construction projects.

Lange Containment Systems fabricates the XR-5 membrane in its factory into custom sized panels to fit each project. The custom sized panels reduce the amount of field seam required resulting in a quicker installation. In addition to the lining materials, Lange Containment Systems is fully equipped to provide accessory materials such as pipe seals and concrete attachment supplies. Installation of the lining materials is performed by Lange Containment Systems installation crews or by the general contractor's labor under the supervision of a Technical Service Representative. Once the installation is finished the project can be completed with a sense of security, knowing that the secondary containment layer is ready to perform.



Project Profile PALAU SEMAKAU LANDFILL Singapore

As the millennium approached, 1999 became the completion date for the first ocean based landfill. This new facility was located off the shores of the island nation of Singapore. Designed to replace a facility nearing capacity, special care was taken to ensure that the landfill wastes would not contaminate the pristine sea waters which surround Singapore. Seaman Corporation's XR-5 liner was chosen to provide the protection for the sea waters. During the design phase it was determined that the high strength reinforcement and seams of XR-5 would be able to withstand the constant abuse from the salt water ocean on one side and the landfill systems on the opposite. To speed installation and raise quality assurance, the XR-5 was factory fabricated into large panels.

Lange Containment Systems Inc., was selected to serve as the fabricator for 100% of the XR-5 fabrication. While producing the 7.3 million square feet, Lange Containment was able to maintain high quality and production as well as continually meet all shipping schedules and deadlines. Every seam produced for this project was tested in-house at Lange Containment's QA/QC laboratory as well as double checked by Seaman Corporation and the on-site inspectors for the Singapore government. After a challenging installation, the XR-5 is in place and performing perfectly. Proof positive that the appropriate product and Lange Containment Systems fabrication can solve the most difficult containment problems.



EZ Containment System



LCSI's EZ Containment™ system has many field applications:

- Tank Guardian. Use as a permanent *or* temporary system around tanks holding oil, fertilizer, water, etc...
- Secondary Containment
- Fire protection water storage
- Water clarity dams
- Truck washing station
- Creek diversions

EZ Containment™ system can usually be installed by one or two persons in just a few hours. The six foot triangular basket panels are easily assembled and disassembled for transportation to another location. We utilize the highest quality materials available in the industry to ensure a functional, durable and long-lasting containment system. And we offer a wide range of geomembrane liners suitable for the liquid material you are storing. Lange's product specialists can help you size and specify the containment system that best fits your needs.

Product Materials & Service

- Triangular baskets are constructed using nine gage galvanized steel with an interior strut
- Nonwoven geotextile underlayment
- Available geomembrane liner materials include:
 - PVC Film- available in 20, 30, 40, 50 and 60 mils
 - Polypropylene available in 45 mil
 - XR-5 available in 30 and 40 mil
 - High strength, High temperature liner available upon request
- Batten strips, anchor spikes and sand-filled ballast tubes
- Optional components:
 - Ladder
 - Walk pads
 - Oil absorbent sock
 - Boot kits
 - Rain water pump
- Collapsible panels for compact transportation
- Easy step-by-step instructions included
- "Next day emergency" shipping on some sizes
- Lange Containment Systems will help you select the correct containment system for your application:
 - Compatibility of geomembrane liner with stored material
 - Customized system for your site specific needs
 - Variety of configurations available





PVC Geomembrane – Mechanical Properties PGI 1104 Specifications¹

Certified Properties ²	ASTM	PVC 20	PVC 30	PVC 40	PVC 50	PVC 60
Thickness	D-5199	20 ±1 mil	30 ± 1.5 mil	40 ± 2 mil	50 ± 2.5 mil	60 ± 3 mil
Tensile Properties ³						
Strength at Break	D-8824 Min	48 lbs/in	73 lbs/in	97 lbs/in	116 lbs/in	137 lbs/in
Elongation	D-8824 Min	360%	380%	430%	430%	450%
Modulus at 100%	D-8824 Min	21 lbs/in	32 lbs/in	40 lbs/in	50 lbs/in	60 lbs/in
Tear Strength	D-1004 ⁴ Min	6 lbs	8 lbs	10 lbs	13 lbs	15 lbs
Dimensional Stability	D-1204 ⁴ Max Chg	4%	3%	3%	3%	3%
Low Temperature Impact	D-1790 ⁴ Pass	-15°F	-20°F	-20°F	-20°F	-20°F
Index Properties ⁵	ASTM	PVC 20	PVC 30	PVC 40	PVC 50	PVC 60
Specific Gravity	D-792 Typical	1.2 g/cc	1.2 g/cc	1.2 g/cc	1.2 g/cc	1.2 g/cc
Water Extraction Percent Loss (max)	D-1239 ⁴ Max Loss	0.15%	0.15%	0.20%	0.20%	0.20%
Average Plasticizer Molecular Weight	D-2124 ^{4,5}	400	400	400	400	400
Volatile Loss Percent Loss (max)	D-12034 Max Loss	0.9%	0.7%	0.5%	0.5%	0.5%
Soil Burial	G1604 Max Chg					
Break Strength		5%	5%	5%	5%	5%
Elongation		20%	20%	20%	20%	20%
Modulus at 100%		20%	20%	20%	20%	20%
Hydrostatic Resistance	D-7514 Min	68 psi	100 psi	120 psi	150 psi	180 psi
Seam Strengths	ASTM	PVC 20	PVC 30	PVC 40	PVC 50	PVC 60
Shear Strength ³	D-882 ⁴ Min	38.4 lbs/in	58.4 lbs/in	77.6 lbs/in	96 lbs/in	116 lbs/in
Peel Strength ³	D-882 ⁴ Min	12.5 lbs/in	15 lbs/in	15 lbs/in	15 lbs/in	15 lbs/in

- Notes:
1. PGI 1104 replaces PGI 1103 Specification effective 1/1/04.
 2. Certified properties are tested by lot as specified in PGI 1104 Appendix A.
 3. Metric values are converted from US values and are rounded to the available significant digits.
 4. Modifications or further details of test are described in PGI 1104 Appendix B.
 5. Index properties are tested once per formulation as specified in PGI 1104 Appendix A.

This information is provided for reference purposes only and is not intended as a warranty or guarantee. LCSi assumes no liability in connection with the use of this information.

Hypalon Geomembrane – Mechanical Properties



Property	Test Method	Minimum Specification*	Typical Avg. Values
Thickness			
1 Total overall (mils)	ASTM D751	34	36 nominal
2. Min. over scrim (mils)	Optical Method	11	Pass
Tensile Properties (each direction)	ASTM D751 Grab Method		
1. Breaking Strength (lbs) Fabric Membrane Rupture		200 150	275 225
2. Elongation at Break Fabric Membrane Rupture		15% 30%	20% 110%
Tear Propagation (lbs)	ASTM D751 Tongue Tear (8" x 8")	80	100
Hydrostatic Resistance (psi)	ASTM D751 Method A Procedure 1	250	405
Puncture Resistance (lbs)	FTMS 101B method 2031	-	240
Bonded Seam Strength (lbs)	ASTM D751, Modified (12in./min)	160	175
Ply Adhesion (lbs./in. width)	ASTM D413 Machine Method, Type A (12in./min)	7 (or film tearing bond)	8
Ozone Resistance	ASTM D1149 1/8" bent loop, 100 pphm 104°F, 7 days	No cracks at 7 x magnification	Pass
Low Temperature ¹	ASTM D2136, 1/8" mandrel, 4 hrs. @ - 40°F	Pass	Pass at -45°F

Notes:

1. These specification tables represent current opinion of the data points to characterize the membrane product as produced and are not necessarily appropriate for product performance or installation or engineering design criteria 'per se'. (For example, the low temperature resistance numbers represent qualities for few minutes at a given temperature and must not be interpreted or extrapolated into installation temperature qualities or comparisons.

This information is provided for reference purposes only and is not intended as a warranty or guarantee. LCS! assumes no liability in connection with the use of this information.

XR-5 Geomembrane – Mechanical Properties



XR-5 [®] 8130 Reinforced	Test Method	Specification
Base Fabric Type	ASTM D3776	Polyester
Base Fabric Weight (nominal)	ASTM D3776	6.5 oz/yd ²
Thickness	ASTM D751	30.0 mils (min.)
Weight	ASTM D751	30.0 ± 2 oz/yd ²
Tear Strength	ASTM D4533, Trapezoid Tear	35/35 lb _f (min.)
Breaking Strength	ASTM D751, Grab Tensile	550/550 lb _f (min.)
Low Temperature	ASTM D2136, 4hr – 1/8" mandrel	Pass @ -30 °F
Dimensional Stability	ASTM D1204, 212°F / 100°C – 1 hr	1.5% max. each direction
Adhesion – Heat Sealed Seam	ASTM D751, Dielectric Weld	35 lb _f /2 in (min.)
Dead Load – Seam Shear Strength	ASTM D751	2 in seam, 4 hr, 1 in strip 210 lb _f @ 70°F 105 lb _f @ 160°F
Bursting Strength	ASTM D751 Ball Tip	650 lb _f (min.) 800 lb _f (typical)
Hydrostatic Resistance	ASTM D751, Method A	800 psi (min.)
Blocking Resistance	ASTM D751 (180°F / 82°C)	#2 Rating (max.)
Adhesion – Ply	ASTM D413	15 lb _f /in (min.) or Film Tearing Bond
Bonded Seam Strength	ASTM D751 as modified by NSF 54	550 lbf (min.)
Abrasion Resistance	ASTM D3389 (H-18 Wheel, 1000 g load)	2,000 cycles (min.) before fabric exposure 50 mg/ 100 cycles max weight loss
Weathering Resistance	ASTM G23 (Carbon-Arc)	8,000 hrs (min.) – No appreciable changes or stiffening or cracking of coating
Water Absorption	ASTM D471, Section 12, 7 days	0.025 kg/m ² (max.) @ 70°F / 21°C 0.14 kg/m ² (max.) @ 212°F / 100°C
Wicking	Shelter-Rite [®] Procedure	1/8 in (max.)
Puncture Resistance	ASTM D4833	250 lb _f (min.)
Coefficient of Thermal Expansion / Contraction	ASTM D696	8 x 10 ⁻⁶ in/in/°F (max.)

This information is provided for reference purposes only and is not intended as a warranty or guarantee. LCS! assumes no liability in connection with the use of this information.



Polypropylene Geomembrane – Mechanical Properties

Physical Property	Test Method	Property Of Unaged Sheet	Property After Aging 672 hrs (28 days) @ 240°F (116°C)
Tolerance on nominal thickness, %	ASTM O 5199 ASTMD 751	0.036", 0.045" & 0.060" ± 10	
Thickness over scrim, in. (mm) 35-mil 45-mil 60-mil	ASTM D4637 Optical Method	0.010 (0.254) min. 0.013 (0.330) min. 0.030 (0.762) min.	
Mass per unit area, lb/ft ² (g/ft ²) (kg/m ²) 36-mil 45-mil 60-mil	ASTM D 5261	0.17 (77) (0.83) typical 0.21 (95) (1.03) typical 0.25 (117) (1.22) typical	
Breaking strength, lbf (kN) (grab tensile at strain rate of 12 in./min.) 36-mil 45 & 60-mil	ASTM D 751 Grab Method A	200 (0.9) min. 260 typ. 250 (1.1) min. 300 typ.	200 (0.9) min. 260 typ. 250 (1.1) min. 300 typ.
Elongation at break of fabric, %	ASTM D 751	25 typical	25 typical
Tearing strength, lbf (N) (2 in./min. strain rate) 36-mil 45 & 60-mil	ASTM D5884 (max. load)	80 (356) min. 130 (578) typ. 100 (445) min. 160 (712) typ.	
Low temperature flexibility, °F (°C)	ASTM D 2135 1/8 in. mandrel 4 hour @ temp.	-40 (-40) max. -50 (-46) typical	
Linear Dimensional Change (Shrinkage), %	ASTM D 1204		+/- 1.0 max -0.5 typical
Ozone resistance, 100 pphm, 168 hours	ASTM D 1149	No cracks	No cracks
Resistance to water (distilled absorption after 30 days immersion 122 °F (50°C) Change in mass, %	ASTM D 471 (coating compound only)	1.0 max 0.5 typical	
Hydrostatic resistance, lbfr/in. 2 or psi (MPA) (Mullen burst) 36-mil 45-mil 60-mil	ASTN D 751 Procedure A	350 (2.4) min. 400 (2.8) typical 450 (3.1) typical 500 (3.4) typical	350 (2.4) min. 400 (2.8) typical 450 (3.1) typical 500 (3.4) typical
Field Seam strength, lbf/in. (kN/m) Seam tested in peel after weld	ASTM D 4437 1 in. wide	30 (5.3) min. 60 (10.5) typical peak value	
Factory Seams, bonded seam strength, lbf (kN), if applicable	ASTM D 751 Grab Method A	200 (0.9) min	
Water Vapor permeance, Perms	ASTM E 96	0.10 max. 0.05 typical	
Puncture resistance, lbf (N) 36-mil & 45-mil 60-mil	ASTM D4833 (index puncture)	85 (378) min 110 (489) typical 118 (525) typical	
Resistance to xenon-arc weathering ¹ Xenon-arc, 15,120 kJ/m ² total radiant exposure, visual condition at 10X	ASTM G 155 0.70 W/m ² 80 °C B.P.T.	No cracks No loss of breaking or tearing strength	

This information is provided for reference purposes only and is not intended as a warranty or guarantee. LCS! assumes no liability in connection with the use of this information.

Geomembrane Chemical Resistance Comparison



	PVC	Hypalon	XR-5®	Polypropylene
Kerosene	C	C	A	C
Diesel Fuel	C	C	A	C
Acids (General)	A	B	A	A
Naphtha	C	B	A	C
Jet Fuels	C	B	A	C
Saltwater 160°F	C	B	A	A
Crude Oil	C	B	A	C
Gasoline	C	C	B	C

A = Excellent
 B = Moderate
 C = Poor
 NF = Not Found in Published Chart

This information is provided for reference purposes only and is not intended as a warranty or guarantee. LCS! assumes no liability in connection with the use of this information.



Typical Mechanical Attachment Detail

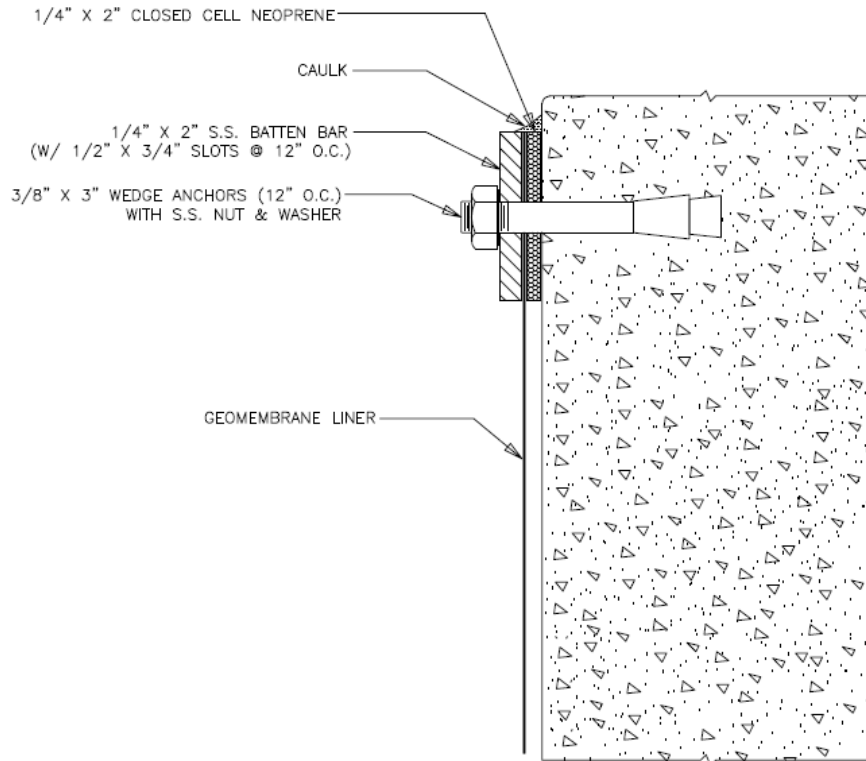

This information is provided for reference purposes only and is not intended as a warranty or guarantee. LCSl assumes no liability in connection with the use of this information.



Typical Pipe Boot Detail

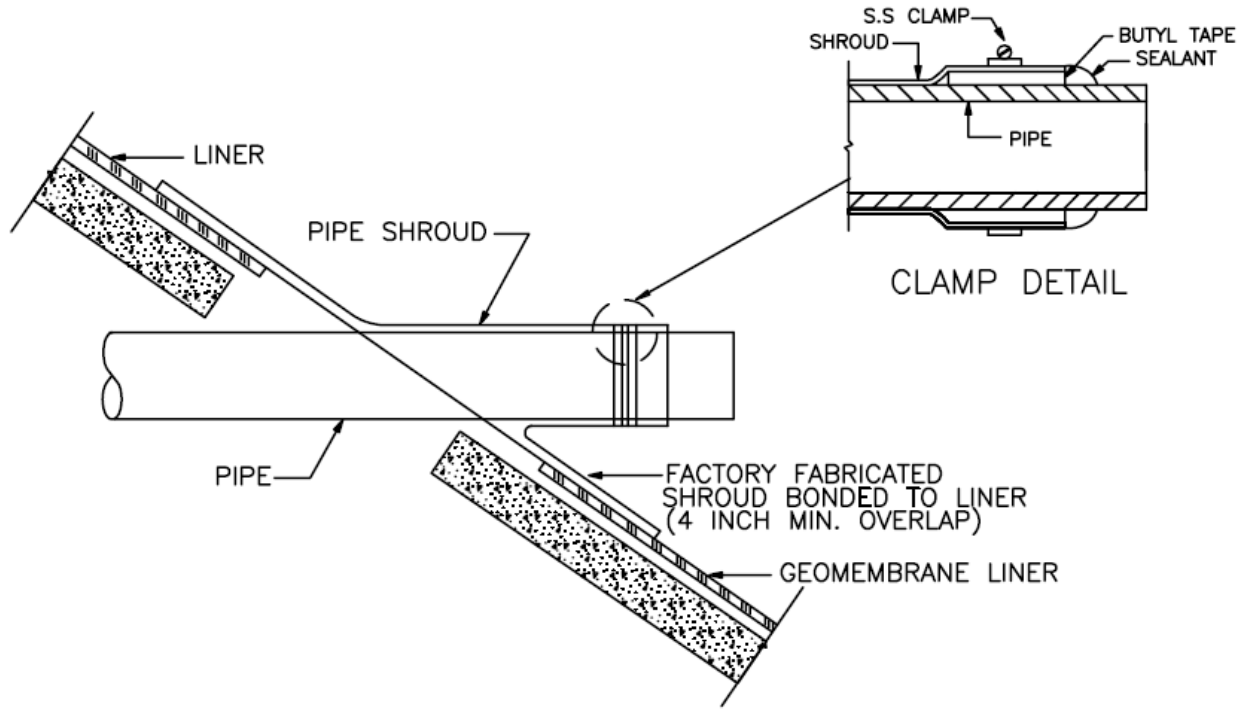

This information is provided for reference purposes only and is not intended as a warranty or guarantee. LCSl assumes no liability in connection with the use of this information.



Typical Air / Gas Vent Detail

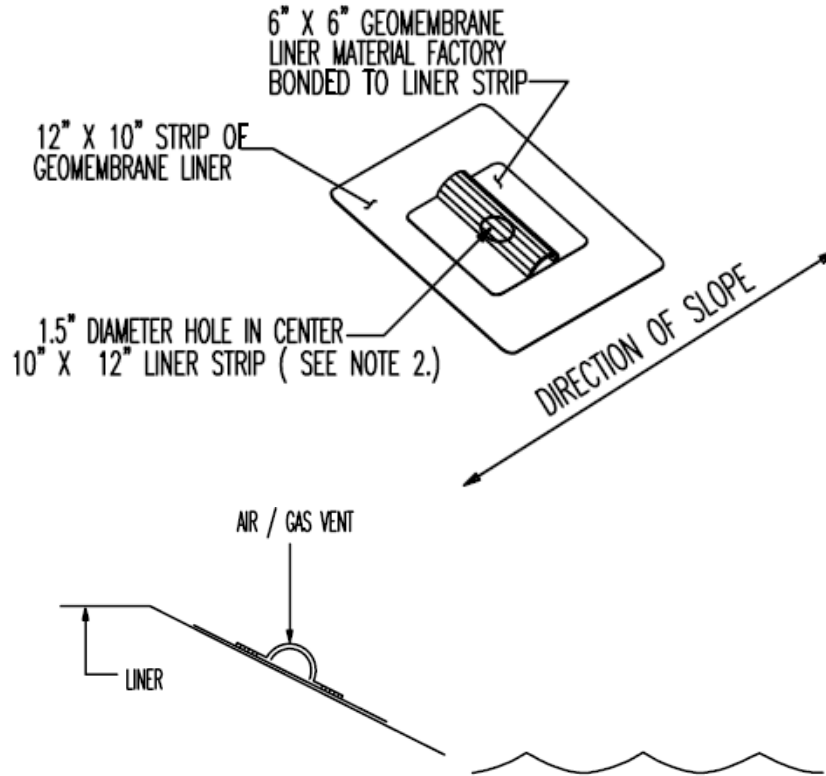

This information is provided for reference purposes only and is not intended as a warranty or guarantee. LCSl assumes no liability in connection with the use of this information.



Typical Palletizing & Unfolding Detail

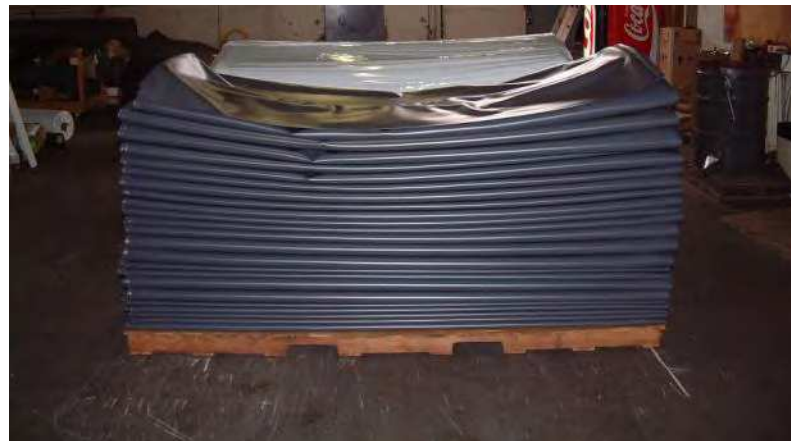
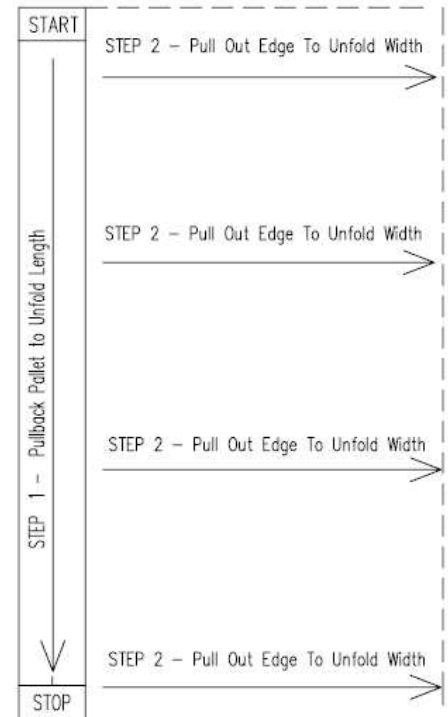
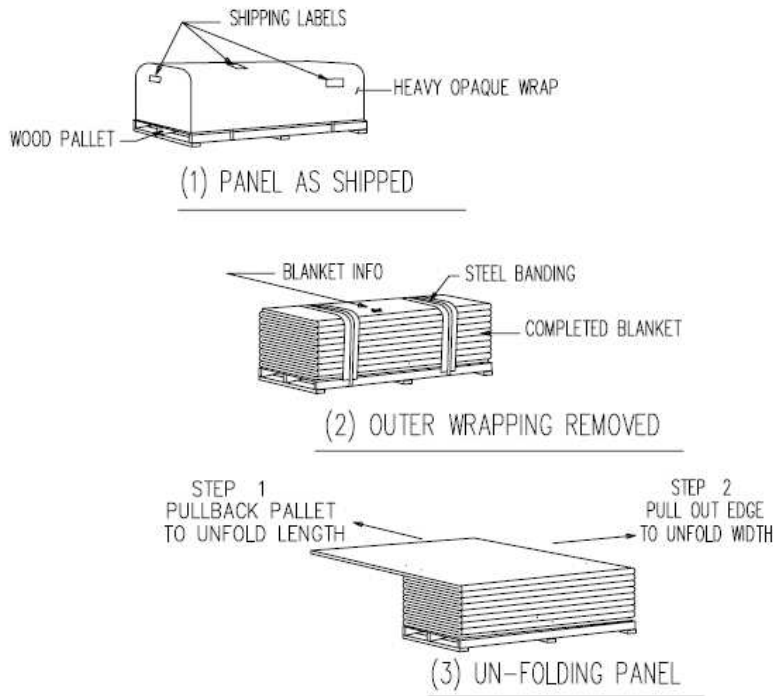

This information is provided for reference purposes only and is not intended as a warranty or guarantee. LCSi assumes no liability in connection with the use of this information.



Thank You for your time in reviewing our
brochure and work.

We welcome your calls and questions, and
look forward to doing business with you in the
future.

Lange Containment Systems, Inc.
5150 Race Court
Denver, CO 80216
Phone: 303-446-8644
Fax: 303-446-8798
Email: LinerGeeks@LangeContainment.com