

CLASS I APPLICATIONS
15 Cubic Feet Maximum

MODEL 2002

TYPE X

RAPID EXCHANGE® PURGING SYSTEM INSTALLATION & OPERATION MANUAL



STD Style
(Standard)



FA Style
(Fully Automatic)

Table of Contents

Page 2	System Purpose and Description Purpose, System Description, Important Notes	Page 15	Electrical Supply Requirements General Wiring Requirements, EPCU Power & Alarm Signal, Enclosure Wiring Methods & Connections
Page 3	Identifying Your System Defines specific features of the system	Page 16	Electrical Power Control Unit General Layout & Conduit Connection Points
Page 4	General Information System & Material Specifications, System Accessories, Spare Parts, Tools & Test Equipment	Page 17	EPCU Power Rating Power Rating Nameplate, Assembled Electronics
Page 5	Enclosure and Device Design Design Requirements, Adjacent Enclosures, Device Ventilation, Temperature Limitations	Page 18	Electrical & Pneumatic Diagrams LH, RH, TM, BM, WM, FM, & PM Configurations
Page 6	Installation Overview Installation Diagram	Page 19	Conduit Installation EPCU Electrical Conduit, Optional Intrinsic Safety Barrier Conduit and EPCU Conduit Connection Parts
Page 7	Getting Started Establishing Connection Sizes, Determining Enclosure Inlet & Outlet Connection Locations	Page 20	Power Modules & Wiring Diagram EPCU 120/220 VAC & 24-48 VDC Power Modules
Page 8	System Mounting LH, RH, TM, BM & WM Configurations, FM & PM Configurations	Page 21	Logic Module & Barrier Wiring Optional ISB Wiring Requirements & Diagram, EPCU Power Control Modes
Page 9	Hardware Mounting Enclosure Protection Vent, Warning Nameplates	Page 22	Barriers & Field Adjustments ISB Description & Factory Programming, LED Display Indicators, Timer Functions & Settings
Page 10	Mounting Plate Dimensions Mounting Plate Dimension Diagrams	Page 23	Set-Up Procedure Rapid Exchange® Purging Set-up
Page 11	Mounting Plate Dimensions (cont.) Mounting Plate Dimension Diagrams	Page 24	Set-Up Procedure (cont.) Rapid Exchange® Purging Set-up
Page 12	Pneumatic Tubing Requirements Protective Gas Supply Requirements, Pneumatic Connection Requirements	Page 25	Operating Sequence Class I Purging Operation
Page 13	Tubing Connection Points LH, RH, TM, BM, WM, FM, & PM Configurations	Page 26	Trouble - Shooting Procedures
Page 14	Tubing Installation LH, RH, TM, BM, WM, FM & PM Tubing Configurations	Page 27	Warranty and Liability Statements Warranty Notes, General Terms, Limitations
		Pages 28 & 29	System Maintenance
		Pages 30 & 31	Customer Notes

Purpose

The Pepperl+Fuchs' Enclosure Protection System's purpose is to allow the use of general purpose or non-rated electrical or electronic devices, with exception to devices which produce excessive heat, utilize combustible gas, or expose arcing contacts to the hazardous atmosphere, in Type 4 or 12 enclosures in the place of explosion proof Type 7 enclosures.

Description

Model 2002 Rapid Exchange® purging system operates on a supply of compressed instrument air or inert gas. It regulates and monitors pressure of sealed (protected) enclosure(s), in order to rapidly remove and prevent flammable vapor accumulation within the enclosure(s). The system is designed to accomplish four air exchanges and maintain a "safe" (0.25") pressure on one or more enclosures not exceeding a total volume of fifteen cubic feet. An EPV-2 Enclosure Protection Vent is required for proper operation. In addition, the system includes an electrical power control unit (EPCU) that monitors system operation and controls enclosure power. All start-up requirements must be satisfied before the EPCU will energize power to the enclosure(s). This process reduces the Hazardous (Classified) Area Rating within the enclosure(s), in accordance with the NEC - NFPA 70, Article 500, NFPA 496 and ISA 12.4.

Important Notes

One (1) permanent file copy and one (1) operations copy of this Manual must be studied and retained by the operator of this System. User's Agents are responsible for transferring this Manual to the user, prior to start-up.

The contents of this manual have been arranged to allow the use of this product as a stand-alone device on equipment and enclosures supplied by the user or its agents. The Manual's parameters encompass both National Fire Protection Association (NFPA) requirements and Pepperl+Fuchs requirements. Pepperl+Fuchs therefore acknowledges the use of NFPA 496 as a guideline, that we have enhanced certain NFPA requirements and that additional information has been compiled to complete this document. The Manual is intended as a complete guide and must be considered, unless specifically stated otherwise, that all directives contained herein are Pepperl+Fuchs requirements for safe, practical and efficient use of this product.

This System is not intended for use to protect enclosures or devices which contain ignitable concentrations of gases or vapors. This exclusion generally applies to process or product analyzing systems equipment.

All specifications are subject to change without notice.

Identifying Your System

This Enclosure Protection System is offered in various styles. For proper installation and operation, examine the System Model Number Nameplate to identify the System Style, Area Classification, and Type, as noted below.

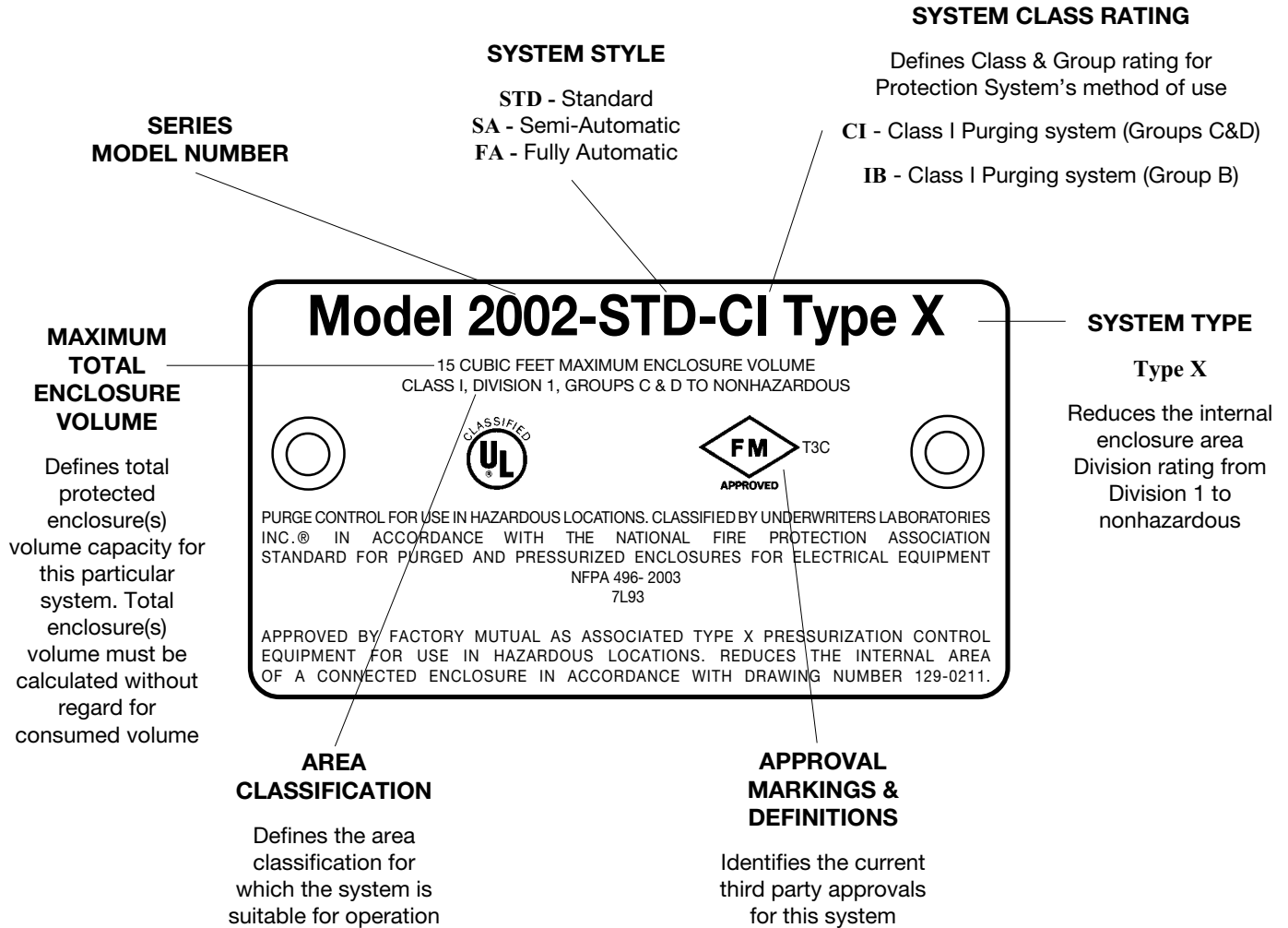

To assist you through the installation and operation of your Rapid Exchange® purge system, Pepperl+Fuchs has provided the following information boxes throughout this manual. This information is intended to clarify certain differences between the model styles and configurations and to warn the user / installer of potential dangers of electrical shock or enclosure over pressurization.

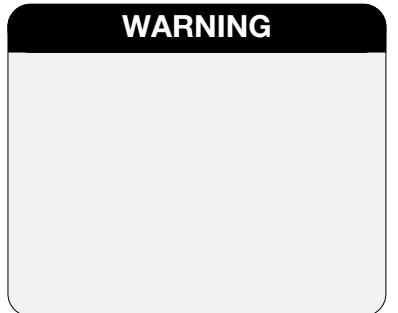
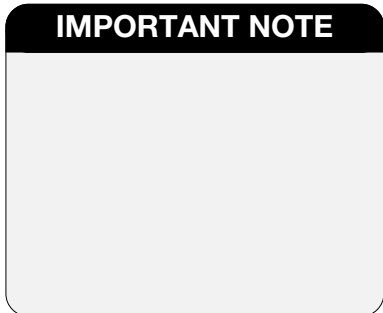
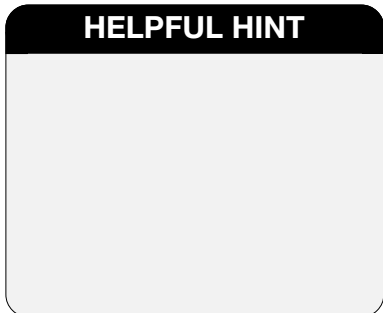

General Information

System Specifications

System Dimensions:	See Pages 10 & 11
Shipping Weight (Lbs.):	STD - 45 / SA & FA - 47
Operating Temp. Range:	-20° F - 120° F
Supply Pressure Range:	80 - 120 PSI max.
Capacity & Filtration:	1.5 Oz. @ 20 Microns
Supply Requirements:	Clean Air or Inert Gas
Safe Press. Setpoint:	0.25" @ Safe Press.
Safe Press. Flowrate:	* 0.1 - 3.5 SCFH / Cubic Ft.
Exchange Pressure:	3" - 5"
Exchange Flowrate:	** 4 SCFM / 240 SCFH
Exchange Time:	1 Minute / Cubic Ft.
System Supply Port:	1/4" FPT
Enclosure Supply Fitting:	1/4" Tube Fitting
Enclosure Reference Fitting:	1/4" Tube Fitting
EPCU Conduit Port Size:	1/2" FPT
EPCU Power Requirements:	120 VAC 60 Hz 1Ø
(European 220 voltage only)	240 VAC 50 Hz 1Ø
EPCU Power Consumption:	500 mA
Power Relay Contacts:	20 Amps @ 240 VAC
	20 Amps @ 28 VDC
Alarm Relay N.O. Contact:	20 Amps @ 240 VAC
	20 Amps @ 28 VDC
Alarm Relay N.C. Contact:	15 Amps @ 240 VAC
	10 Amps @ 28 VDC

* Enclosure integrity determines actual flow rate
 ** With regulator set to 60 PSI min. during exchange

Material Specifications

Filter Regulator Body:	Zinc w/ Enamel Finish
Regulator Handle & Bowl:	Polycarbonate
Enclosure Pressure Gauge:	Alum. w/ Enamel Finish
Rapid Exchange Gauge:	Poly Case & Brass Tube
Rapid Exchange Solenoid:	Brass w/ Enamel Finish
Tube Fittings & Valves:	316 SS Forged Body
Tubing:	316 SS 1/4" .035 Welded
System Nameplates:	Silkscreened Lexan® & SS
Fastener Hardware:	SS Screws & Bolts
Mounting Plate:	316 14 Ga #3 Brush SS
EPCU Enclosure Body:	Bead Blast Cast Alum.
Conduit & Fittings (SA & FA):	Galvanized Steel
Enclosure Warning Nameplate:	Silkscreened SS

Lexan® is a registered trademark of the General Electric Corporation

Recommended Spare Parts

Qty	Description	Part # (supercedes)
1	Enclosure Pressure Indicator	510023 (001000)
1	1/4" Filter Regulator	510057 (002040)
1	Enclosure Pressure Control Valve	510116 (003440)
1	Rapid Exchange® Valve Body (STD Style)	510118 (003460)
1	1/4" Solenoid Valve Body (SA & FA Style)	510075 (002220)
1	Safe Pressure Switch	510356 (005200)
1	Rapid Exchange® Pressure Switch	510358 (005210)
1	Series 2000 Logic Module-Ver. 2.0	510279 (005000)
1	Series 2000 VAC Power Module	510304 (005020)
1	Series 2000 VDC Power Module	510305 (005021)
1	Installation & Operation Manual	129-0211
1	Enclosure Warning Nameplate-CI	513008 (EWN-1)

Reference part number above for current spare parts pricing. Immediate pricing is available to all confirmed customers.

Installation Tools & Testing Equipment

1/2" chuck drill
 Complete set of drill bits
 1/2" & 3/4" conduit knockout punch or 1" hole saw
 Complete set of tubing, conduit bending, instrument fitting and electrical craftsman hand tools
 0 - 5" differential pressure gauge or manometer (connected to the protected enclosure to measure maximum pressure)

Model 2002 System Accessories

Enclosure Protection Vents

ONE REQUIRED WITH EACH SYSTEM

EPV-2-SA-00	Straight w/ Spark Arrestor
EPV-2-SA-90	Rt Angle w/ Spark Arrestor

Additional Items

SMK -2, -3 or -10	System Mounting Kit
RAH	Div. 1 Remote Alarm Horn
RAB-1	Div. 1 Remote Alarm Beacon
LCK	L Fitting Conduit Kit
TCK	T Fitting Conduit Kit
SRM-4000	Switch Resistor Module
NJ...	P+F NAMUR Sensor

Factory Installed Items

IS-A-1	Channel A Barrier
IS-B-2*	Channel B Barrier
IS-C-3*	Channel C Barrier
RP1	Redundant Safe Pressure Switch
RP2	Redundant Rapid Exchange® Pressure Switch
L	Key Lock Assembly

*Requires custom programming information

Enclosure & Device Design

Enclosure Design Requirements

1. All windows must be shatterproof and sized as small as possible.
2. All NFPA 496 required markings must be placed on or near **all** enclosure doors and covers.
3. The enclosure must withstand an internal pressure of five (5) inches of water without sustaining permanent deformation and resist all corrosive elements in the surrounding atmosphere.
4. All lightweight objects in the enclosure, such as paper or insulation, must be firmly secured.
5. The enclosure should be constructed from materials such as metal or anti-static polycarbonate to meet or exceed Type 4 or 12 performance requirements, but does not require third party approval.
6. The installation of obstructions or other barriers which block or impede the flow of protective gas must be avoided.
7. The creation of air pockets or other areas which trap flammable gases within the enclosure or devices must be avoided.
8. The enclosure should be located in an area where impact hazards are minimal.
9. If the enclosure is nonmetallic and contains equipment which utilizes or switches power loads greater than 2500 VA, it must be constructed from substantially noncombustible materials, such as materials designed to meet or exceed ANSI/UL94 ratings of 94 V-0 or 94 5V.

Adjacent Enclosures

1. Adjacent enclosures must be protected by one of the following means:
 - a) purged or pressurized in series with the protected enclosure;
 - b) purged or pressurized separately; or
 - c) protected by other means; e.g. explosion proof enclosures, hermetically sealed devices or intrinsic safe circuits.
2. Adjacent purged or pressurized enclosures must be designed to meet all construction requirements above.

Total Volume Calculation

1. The total volume of all pressurized enclosures, devices and wireways must be considered.
2. All enclosure, device and wireway volumes must be calculated without consideration of internally consumed space.

Device Ventilation

1. Enclosed devices within the protected enclosure which do not exceed 1.22 cubic inches of free volume do not require ventilation to the protected enclosure.
2. If the free volume of an internal device exceeds 1.22 cubic inches it must be protected by one of the following means:
 - a) ventilated on the top and bottom sides with one (1) square inch of opening for each four hundred (400) cubic inches of volume within the internal protected enclosure, at a minimum diameter of one (1) quarter inch;
 - b) purged in series with the protected enclosure or be purged separately; or
 - c) protected by other means; e.g. explosion proof devices, hermetically sealed housings or intrinsic safe circuits.

Temperature Limitations

1. The enclosure must have no surface area which exceeds 80 percent of the flammable or ignitable substance's auto-ignition temperature.
2. Internal devices which exceed this temperature must be protected by one of the following manners.
 - a) The device is enclosed in a chamber which is cUL or FM listed as a hermetically sealed device which prohibits the entrance of flammable or ignitable substance, and maintains a surface temperature below temperature limits.
 - b) It can be proven by testing that the devices will not ignite the substance involved.
 - c) The device is purged in a separate enclosure that bears an ETW (Enclosure Temperature Warning Nameplate). Devices may only be accessed after power has been removed and the device has been allowed to cool to safe temperature, or the area is positively known to be nonhazardous.

Installation Overview

Typical Left Hand Configuration Installation Diagram

Model 2002-STD-CI-LH Shown

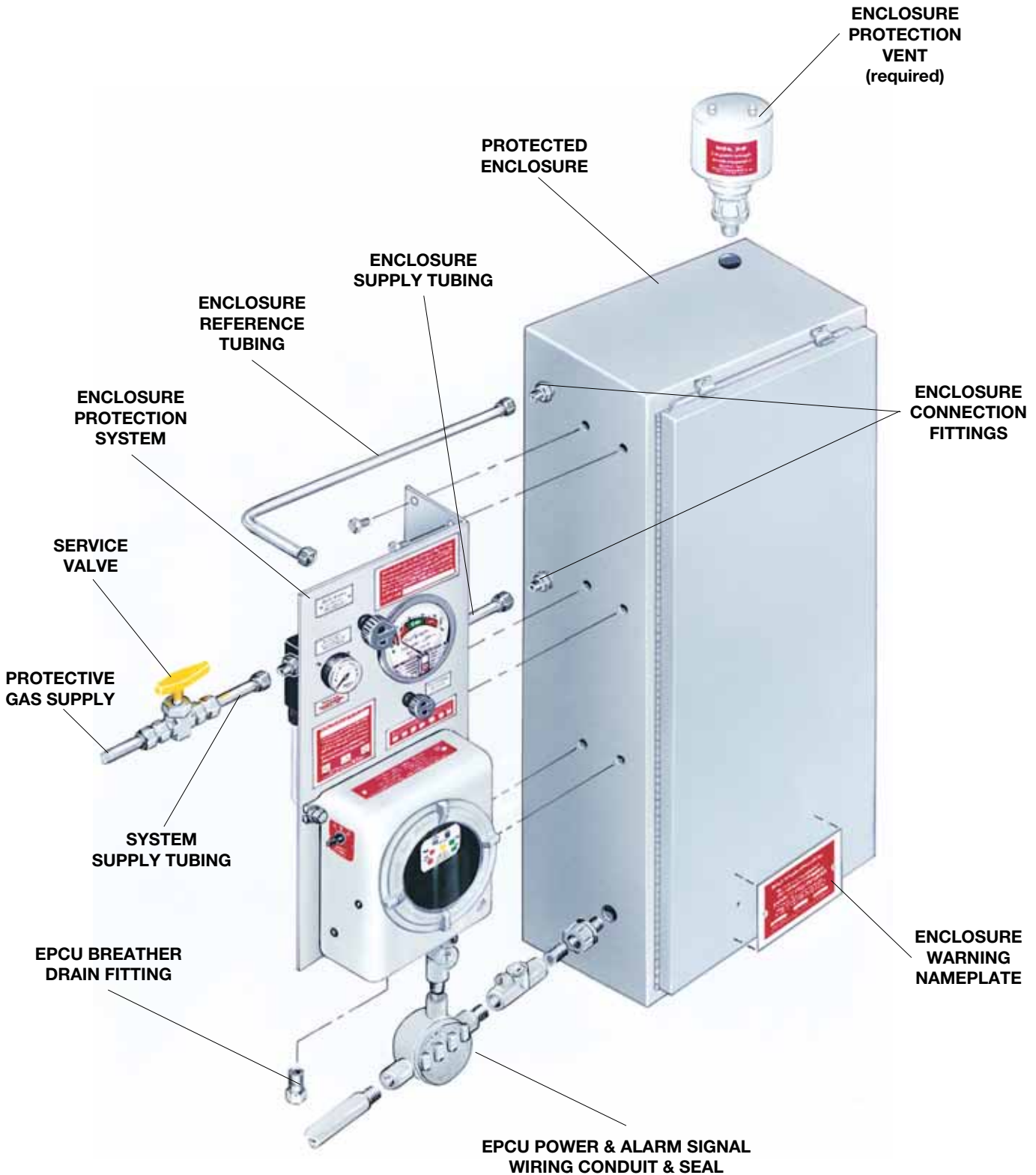

Getting Started

Establishing Connection Sizes, Lengths & Bends

TYPICAL SINGLE PROTECTED ENCLOSURE CONNECTIONS

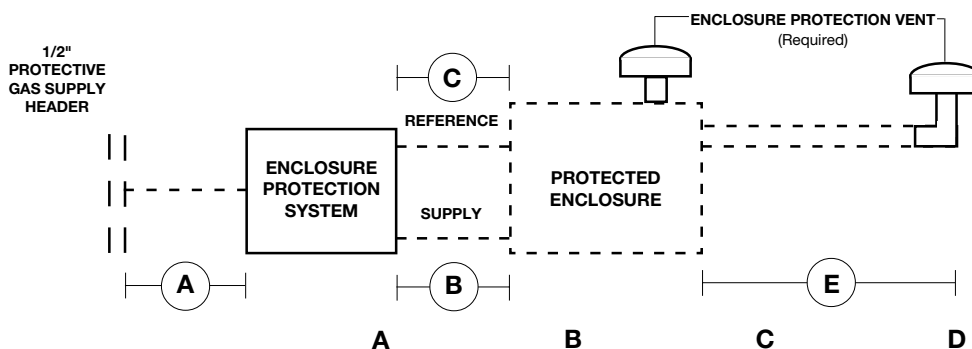

Description	System Supply Tubing	Enclosure Supply	Enclosure Reference	Multi - Enclosure Connections	Optional Remote Venting
*Tubing or Pipe Diameter	1/4" O.D. Tubing Fully Reamed	1/4" O.D. Tubing Fully Reamed	1/4" O.D. Tubing Fully Reamed	3/4" I.D. Pipe Fully Reamed	3/4" I.D. Pipe Fully Reamed
Maximum Tubing / Pipe Length and Maximum Number of Bends / Elbows	20 Feet 10 Bends	5 Feet 5 Bends	20 Feet 10 Bends	10 Feet 5 Elbows	30 Feet 5 Elbows

TYPICAL MULTIPLE PROTECTED ENCLOSURE CONNECTIONS

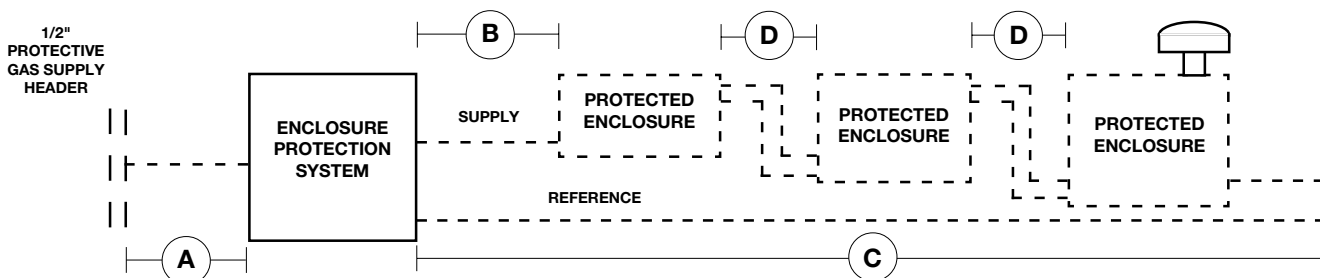

*NOTE: Tube and pipe sizes are trade sizes and are not equal in inside diameters. DO NOT substitute tube for pipe with same trade size.

HELPFUL HINTS

To ensure adequate protective gas flow to protected enclosure(s), all piping and tubing must be fully reamed. Precautions must be taken to prevent crimping and other damage to protective gas piping and tubing. When protecting multiple enclosures with a single enclosure protection system, the enclosures must be connected in series from the smallest to the largest to ensure adequate protective gas flow.

Determining Enclosure Inlet & Outlet Connection Locations

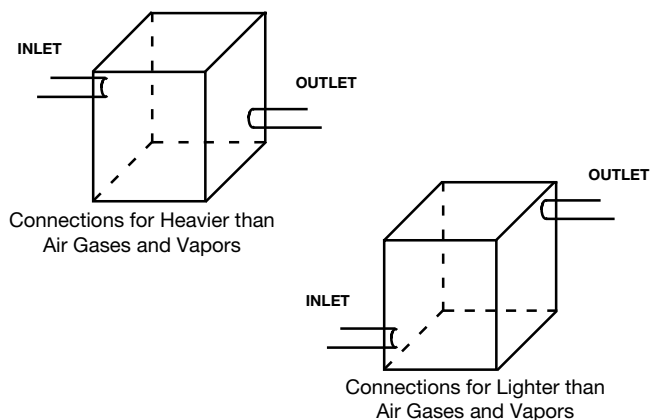

HELPFUL HINTS

If flammable gases are lighter than air, the inlet connection to each enclosure must enter near a bottom corner. The outlet connection, for an optional enclosure protection vent or piping to an adjacent protected enclosure, must exit near an extreme opposite top corner. See diagrams to the left. If flammable gases are heavier than air, inlet and outlet connections must be reversed. In all cases, the most prevalent gas must determine the location of inlet and outlet connections.

System Mounting

IMPORTANT NOTES

The system should be mounted at **EYE LEVEL**.

Care must be taken to ensure the system and all protruding components are clear of all enclosure accesses (doors and covers) and conduit, pipe, tubing or cable entries.

LH, RH, TM, BM and WM configurations are intended for mounting adjacent to the protected enclosure.

LH, RH, TM & BM configurations are also suitable for 2" schedule 40 pipe mounting.

Determine the mounting configuration of your system using the diagrams on pages 10 & 11.

Remove and save the manila envelope (containing the enclosure warning nameplate) which may be taped to the outer surface of the mounting flange.

Although all Bebco systems are factory tested and calibrated, we strongly suggest a bench test of basic functions prior to installation.

Mounting LH, RH, TM, BM & WM Configurations

1. Transfer hole pattern of System mounting plate to intended surface.
2. Check for obstructions hindering bolt fastening, drill and ream the mounting holes before mounting the system.
3. Secure the system to the enclosure, or other mounting surface, using one (1) SMK-3 or equivalent - six (6) 3/8" x 3/4" stainless steel bolts, nuts and lock washers.

*WM requires one (1) SMK-2 or equivalent - four (4) 3/8" x 3/4" stainless steel bolts, nuts and lock washers.

Mounting FM & PM Configurations

HELPFUL HINTS

FM and PM configurations are designed to mount through a panel cutout one (1) inch smaller than the overall height and width of the system mounting plate, using clips and fasteners provided with SMK -10. This design feature eliminates the need to drill the system mounting bolt holes in the protected enclosure.

FM configurations are intended for mounting adjacent to the protected enclosure.

PM configurations are intended for mounting through a cutout in the protected enclosure surface.

1. Transfer panel cutout pattern to the intended surface.
2. Check for obstructions which could prohibit bolt fastening or system pneumatic and electrical connections.
3. Cut panel cutout pattern on the intended surface.
4. Deburr all cutout surfaces.
5. Secure system to enclosure using SMK-10, or equivalent - ten (10) 1/4" x 3/4" stainless steel nuts, bolts, mounting clips and lock washers.

Typical Examples of Surface, Pipe, Panel & Frame Mounted Systems



Typical Surface Mounted System
(Model 1002-LPS-LH Type Z shown)



Typical Pipe Mounted System
(Model 1002-LPS-LH Type Z shown)



Typical Panel/Frame Mounted System
(Model 1002-LPS-PM Type Z shown)

Hardware Mounting

Required Enclosure Protection Vent

All configurations must be mounted in a true vertical position.

The vent must be located to provide access for routine testing of the vent's flapper assembly. A minimum 8" clearance is required below the vent opening.

1. Determine the vent's mounting configuration, i.e.; -00 vertical mount or -90 side mount. (See photos below)
2. Determine vent location and layout vent mounting hole on the protected enclosure. (As determined on page 7, "Getting Started")
3. Using a 1" hole saw or 3/4" conduit punch, drill and deburr the enclosure protection vent mounting hole.
4. Remove the hub mounting nut from the vent hub and place the hub, with O-ring intact, through the mounting hole. The O-ring must be on the outside of the protected enclosure.
5. Reinstall the hub mounting nut to the mounting hub from inside the protected enclosure and tighten.



EPV - 2 - SA - 00
Vertical Mount



EPV - 2 - SA - 90
Side Mount

Warning Nameplate(s)

An EWN (Enclosure Warning Nameplate) must be located in a prominent position on or near **all** enclosure accesses (doors and covers).

One (1) EWN is provided with each system, located in the manila envelope taped to the mounting flange of the system. Additional EWN's are available from Pepperl+Fuchs.

All EWNs provide labeled spaces allowing the customer to mark the protected enclosure with: 1) a T Code (temperature identification number), 2) Class, Group and Division of surrounding area, and 3) NFPA pressurization Type X, Y or Z, as may be required by plant and local codes and is required by NFPA 496.

An ETW (Enclosure Temperature Warning nameplate) must be located in a prominent position on or near all enclosure accesses (doors and covers) when the temperature of an internal component exceeds 80 percent of the ignition temperature of the flammable vapor, gas or dust involved.

An ETW warns the operator to deenergize all equipment for a specified length of time, allowing the protected equipment to cool before opening the protected enclosure. The length of time required is determined by the customer and can be factory or field engraved.

All EWNs and ETWs are furnished with an adhesive back, but should also be riveted or screwed to the protected enclosure.

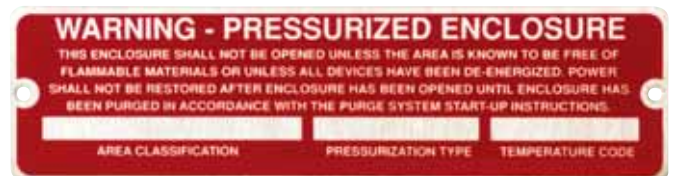

Enclosure Warning Nameplate - Class I



Enclosure Warning Nameplate - Class II



Enclosure Temperature Warning Nameplate

Mounting Plate Dimensions

Model 2002

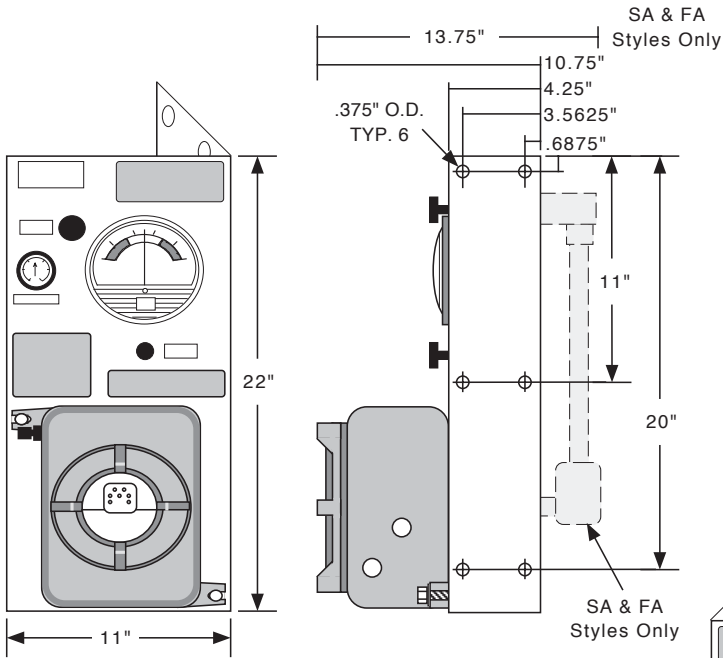

2002-LH
(Left Hand Configuration)

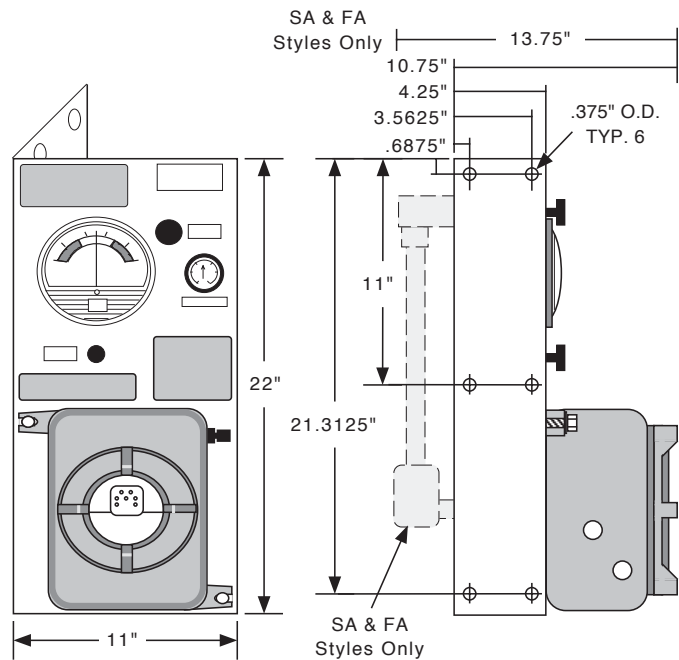

2002-RH
(Right Hand Configuration)

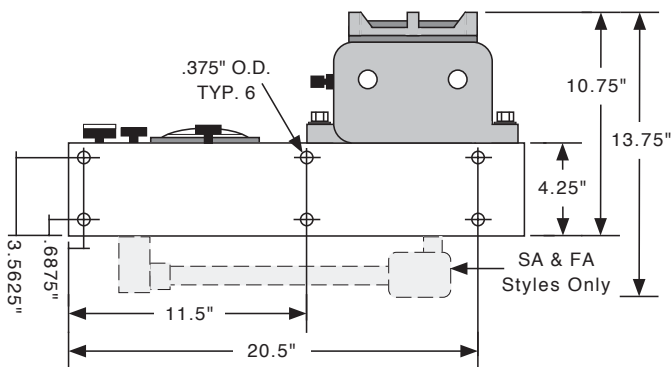
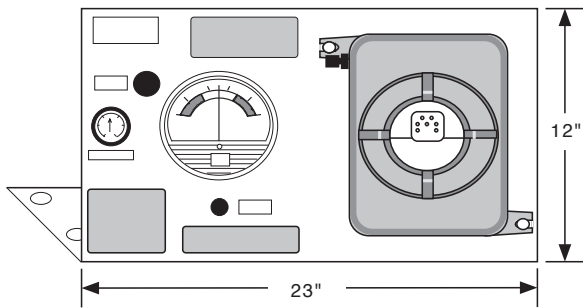

2002-TM
(Top Mount Configuration)

IMPORTANT NOTE

Dimensions DO NOT include Systems ordered with an Area Classification of IB (Class I, Division 1, Group B). Consult factory for mounting plate dimensions.

Mounting Plate Dimensions (cont.)

Model 2002

IMPORTANT NOTE

Dimensions DO NOT include Systems ordered with an Area Classification of IB (Class I, Division 1, Group B). Consult factory for mounting plate dimensions.

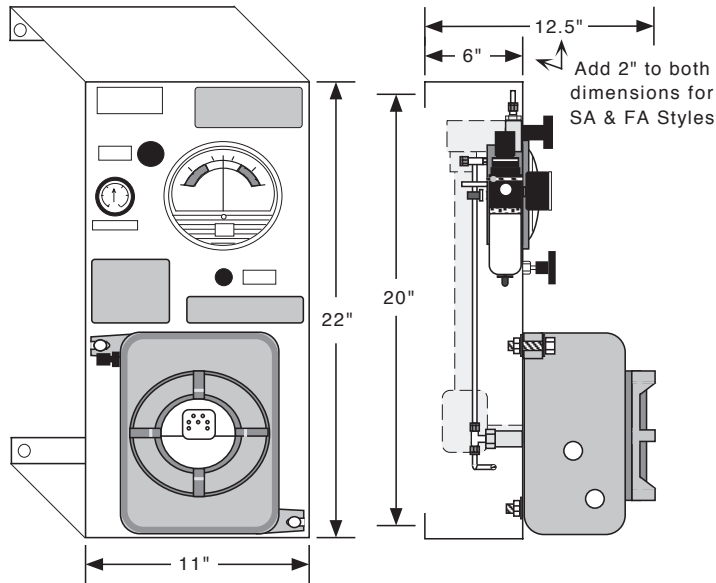

2002-WM
(Wall Mount Configuration)

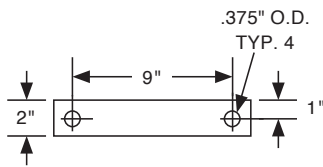

TYPICAL -WM
MOUNTING FLANGE

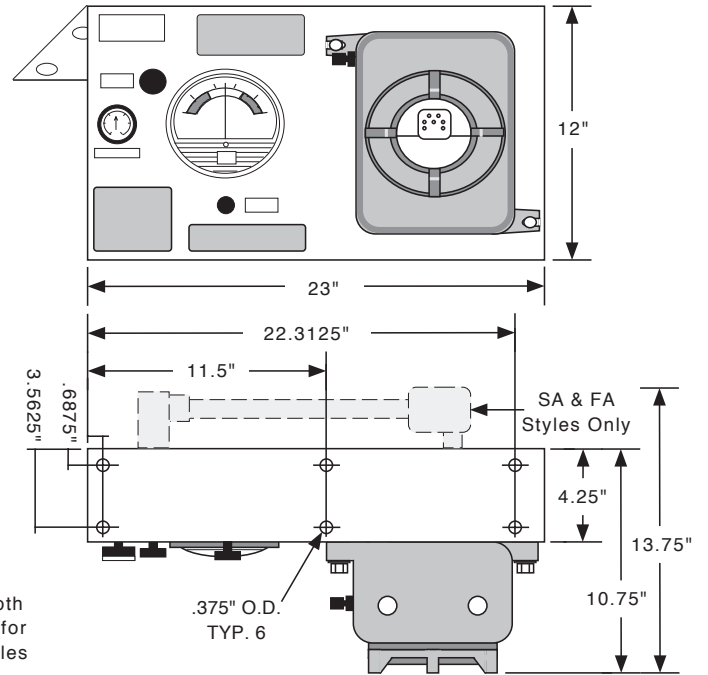

2002-BM
(Bottom Mount Configuration)

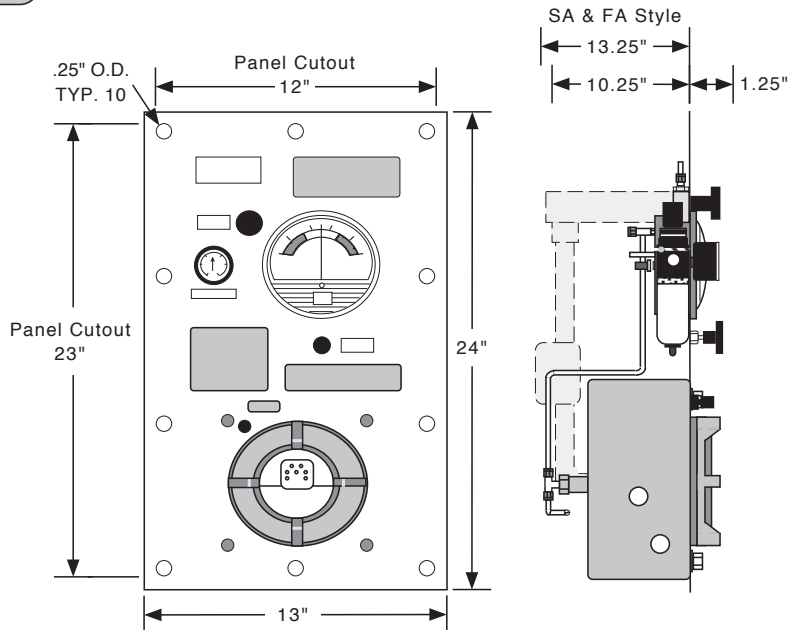

2002-FM & 2002-PM
(Frame & Panel Mount Configuration)

Pneumatic Tubing Requirements

Protective Gas Supply Requirements

The protective gas supply to the protection system must be a clean, instrument quality compressed air or nitrogen and must contain no more than trace amounts of flammable gas, vapor or dust.

The protective gas supply compressor intake must originate in a nonhazardous location. Suction duct passing through a hazardous location and the protection system tubing and piping must be fabricated from noncombustible materials suitable for prevailing hazards and environmental conditions.

The protective gas supply must originate from a dedicated instrument quality compressed air header (1/2" pipe or larger), no farther than twenty (20) feet from the protection system. Local compressors and gas cylinders should not be used before consulting with Pepperl+Fuchs.

The protective gas supply to the protection system must be regulated from 120 psi maximum to 80 psi minimum.



SC-4



NC-4

SYSTEM SUPPLY FITTINGS



EFC-4



EBC-4

ENCLOSURE SUPPLY & REFERENCE FITTINGS



EPC-12

MULTIPLE ENCLOSURE CONNECTION FITTING

Pneumatic Connection Requirements

ALL FITTINGS MAY BE CUSTOMER OR FACTORY FURNISHED

1. For system supply, one (1) SC-4 1/4" Male Straight Connector or one (1) NC-4 1/4" Male Elbow Connector or equivalent fitting per system.

One (1) similar fitting which will connect the inert gas supply tubing to the inert gas supply header connection point and one (1) lot of 1/4" O.D., .035" wall thickness, welded or seamless stainless steel tubing.

2. For enclosure supply, one (1) EFC-4 1/4" Flush Connector, or one (1) EBC-4 1/4" Feed-Through Connector or equivalent fitting per system.
3. For enclosure reference, one (1) EFC-4 1/4" Flush Connector, or one (1) EBC-4 1/4" Feed-Through Connector or equivalent fitting per system.
4. One (1) lot of 1/4" O.D., .035" wall thickness, welded or seamless stainless steel tubing.
5. For multiple enclosure connections, two (2) EPC-12 3/4" Pipe Mounting Hubs or equivalent and 3/4" 150# rated pipe couplings & unions per interconnection.

One (1) lot 150# rating 3/4" galvanized or aluminum pipe and fittings, fully reamed and unrestricted.

PM Pneumatic Connection Requirements

In addition to item numbers 1, 4 and 5 above, the following fittings are required for all PM configurations.

1. For system supply on PM configurations, one (1) additional EBC-4 or equivalent 1/4" Through Bulkhead Fitting per system is required.
2. For atmospheric reference, one (1) PRB-4 or equivalent 1/4" female bulkhead fitting and stainless steel sintered element is required.



PRB-4

SYSTEM ATMOSPHERIC REFERENCE FITTING

Tubing Connection Points

LH, RH, TM, BM, WM & FM Configuration Connection Points

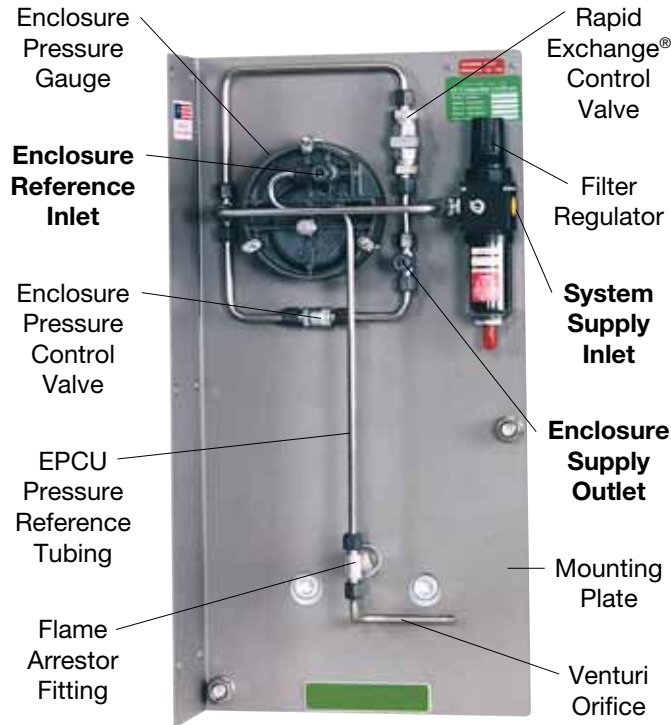

STD Style

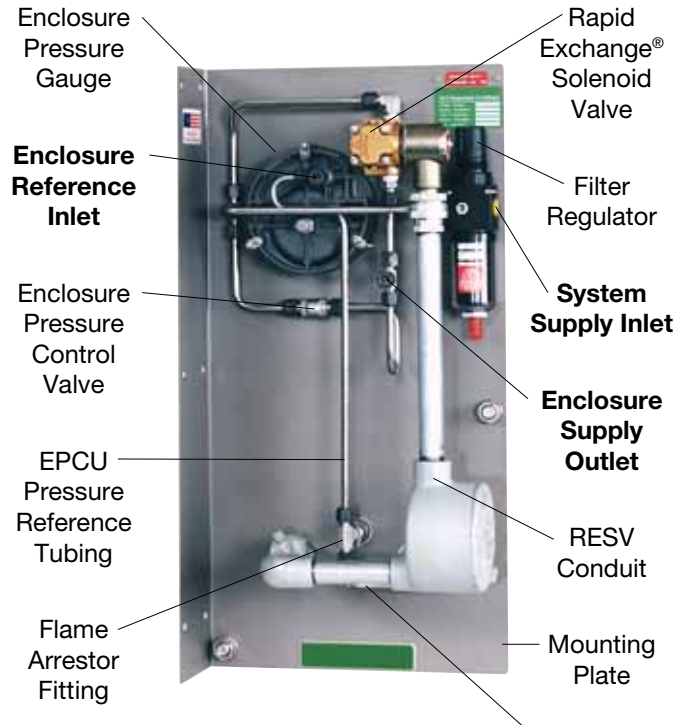

**SA & FA Style
(with Rapid Exchange[®]
Solenoid Valve)**

PM Configuration Connection Points

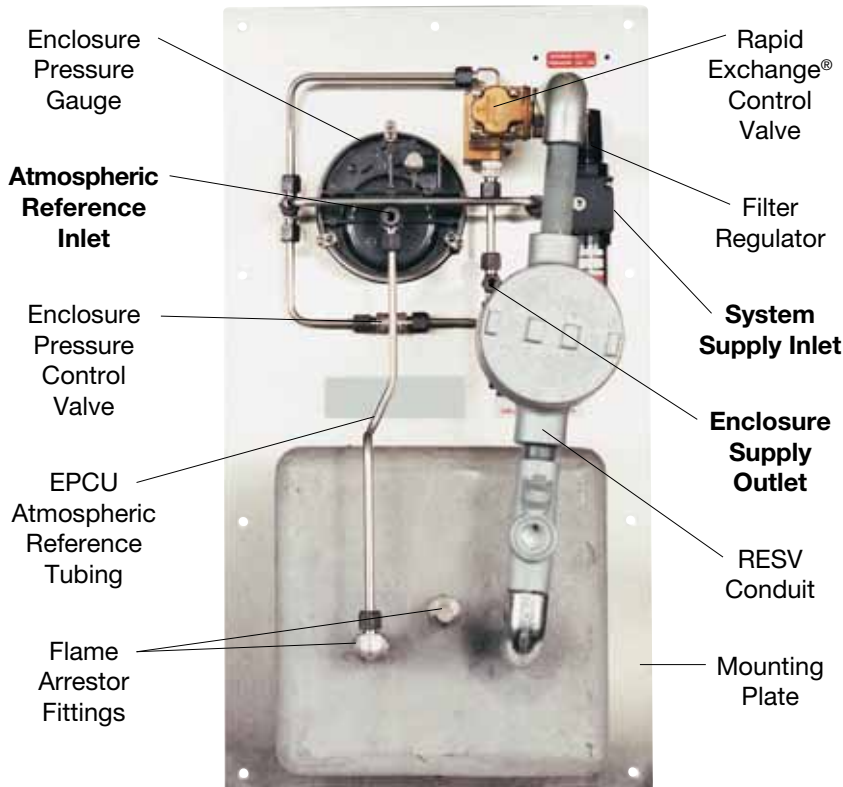

HELPFUL HINT

Pneumatic Connections are bolded.

Tubing Installation

HELPFUL HINTS

All work must be performed by technicians qualified in pneumatic tubing and electrical conduit installation.

Pepperl+Fuchs recommends the use of .035" wall thickness, welded or seamless stainless steel tubing. If flexible tubing is used, it must be installed in a manner which will protect it from damage and corrosion.

Tubing LH, RH, TM, BM, WM & FM Configurations

System Supply Connections

1. Select or install a protective gas supply header tap, fitted with the proper tube size fitting and located within twenty (20) feet of the enclosure protection system.
2. If a service valve is placed between the protective gas supply header and the enclosure protection system, it must be installed in close proximity of the protected enclosure and be labeled in accordance with NFPA 496, 2003 edition.
3. Select the appropriate fittings required to connect the protective gas supply to the protection system regulator as determined on page 12, "Pneumatic Tubing Requirements".
4. Determine appropriate tubing route from the protective gas supply header to the protection system regulator.
5. Bend tubing using industrial grade benders, check tubing fit to ensure proper seating between the tubing and fittings. Fully ream all tubing ends.
6. Install tubing and tighten all fittings to fitting manufacturer's specifications. Secure tubing to appropriate structural supports as required.

Enclosure Supply & Reference Connections

1. Choose location for the enclosure supply connection(s) based on the requirements on page 7, "Getting Started".
2. Place the enclosure reference connection fitting directly behind the enclosure protection system whenever possible. For systems protecting multiple enclosures in series, the enclosure reference connection fitting must be placed on the last enclosure in the series. (See page 7, "Getting Started")
3. Drill and deburr enclosure supply and reference fitting holes on the protected enclosure. Mount the fittings.
4. Determine appropriate route for the enclosure supply and reference tubing.
5. Bend tubing using industrial grade benders, check tubing fit to ensure proper seating between the tubing and fittings. Fully ream all tubing ends.
6. Install tubing and tighten all fittings to fitting manufacturer's specifications. Secure tubing to appropriate structural supports as required.

Tubing PM Configurations

Enclosure Bulkhead Fittings

1. Select the fittings required to install the System Supply, System Supply Bulkhead Fitting and Atmospheric Reference Bulkhead Fitting, (see page 12, "Pneumatic Tubing Requirements").
2. Choose location for the system supply bulkhead fitting. This fitting allows the protective gas supply to pass through the wall of a protected enclosure to the protection system's regulator supply inlet connection.
3. Choose location for the atmospheric reference bulkhead fitting. This fitting allows the enclosure pressure gauge and Electrical Power Control Unit (EPCU) to reference atmospheric pressure.
4. Drill and deburr system supply and reference bulkhead fitting holes in the protected enclosure. Mount the fittings.

System Supply & Reference Connections

1. Select or install a protective gas supply header tap, fitted with the proper tube size fitting and located within twenty (20) feet of the enclosure protection system.
2. If a service valve is placed between the protective gas supply header and the protection system, it must be in close proximity of the protected enclosure and labeled in accordance with NFPA 496.
3. Determine appropriate tubing route from the protective gas supply header to the system supply bulkhead fitting.
4. Determine appropriate tubing route from the system supply bulkhead fitting to the protection system regulator.
5. Determine appropriate tubing route from the atmospheric reference bulkhead fitting to the enclosure pressure gauge's reference inlet connection.
6. Bend tubing using industrial grade benders, check tubing fit to ensure proper seating between the tubing and fittings. Fully ream all tubing ends.
7. Install tubing and tighten all fittings to fitting manufacturer's specifications. Secure tubing as required.

Electrical Supply Requirements

General Wiring Requirements

WARNING

THIS DEVICE CONTAINS ELECTRICAL PARTS WHICH CAN CAUSE SHOCK OR INJURY

All electrical connections, conduit and fittings on the protected enclosure must be suitable for the hazardous location in which they are installed. In addition, all conduit and wire must be installed in accordance with NEC articles 500-1, 500-2 or 500-3 as required and all relevant plant and local codes.

Conduit seals must be utilized on all electrical conduit connections and poured with an approved compound prior to operation of the protection system.

Exception: Do not use seals on conduit used as a protected "wireway" to supply protective gas to adjacent protected enclosures. The same conduit can be utilized for both electrical and pneumatic service to an adjacent protected enclosure(s), provided the conduit is oversized to allow a minimum free clearance equal to or larger than the pipe size required between multiple enclosures as stated on page 7, "Getting Started".

HELPFUL HINT

Pepperl+Fuchs recognizes it may be impractical to pour all electrical conduit seals prior to installation in the field. However, all conduit connections must be sealed for proper testing and operation of the Enclosure Protection System. Therefore, Pepperl+Fuchs recommends the use of temporary seals such as duct seal or masking tape for bench or shop testing, prior to final field installation.

EPCU Power Requirements

The Electrical Power Control Unit's (EPCU) electrical power source must originate from a circuit breaker or fused disconnect suitable for the hazardous location in which it is installed. The power source should be uninterrupted and the switch must be located within fifty (50) feet of the protected enclosure(s) and the enclosure protection system and be properly marked. For EPCU power specifications see page 4, "System's Specifications".

Alarm Signal Requirements

Pepperl+Fuchs strongly recommends use of the optional alarm system contacts of the EPCU, connected to an alarm system located in a constantly attended location to indicate the failure of the enclosure protection system. For EPCU alarm signal specifications see page 4, "System's Specifications".

Typical Enclosure Wiring Methods

In a general sense, protected enclosures should be wired similar to explosion proof enclosures, in accordance with **Article 500** of the National Electric Code - **NFPA 70**.

Single conductor wiring should be placed in rigid metal conduit, seal-flex conduit or other mediums approved for use in the hazardous location surrounding the protected enclosure. Additionally, **NFPA 496** requires the use of approved seals on all pressurized enclosure conduit wiring entries, in accordance with **NFPA 70**. Furthermore, the use of an approved seal is simply the most practical way to prevent excessive leakage through conduit connections.

However, while explosion proof enclosures require conduit seals on all cable entries, in accordance with **NFPA 70**. Other methods of sealed cable entries that are suitable for hazardous locations can be used, such as compression glands.

In conclusion, there are two primary goals. First, the installer should ensure that all associated wiring and cable is protected by pressurization or other means, such as explosion proof conduit or intrinsic safety barriers. Secondly, the installer should ensure that all associated conduit and wireways are sealed to conserve protective gas, unless they are used to supply protective gas to other enclosures or devices.

Typical Enclosure Wiring Connections

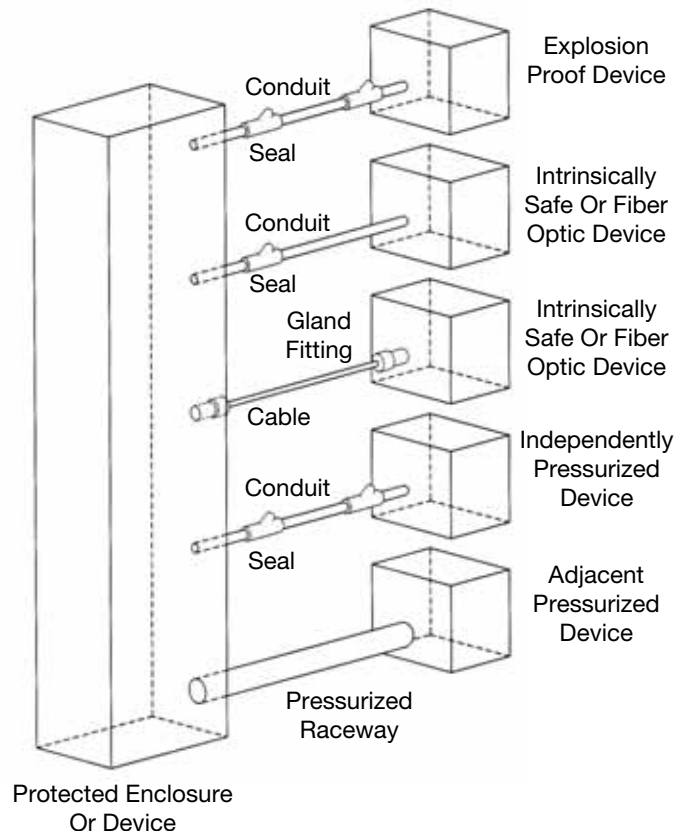

Electrical Power Control Unit

General Layout & Electrical Conduit Connections

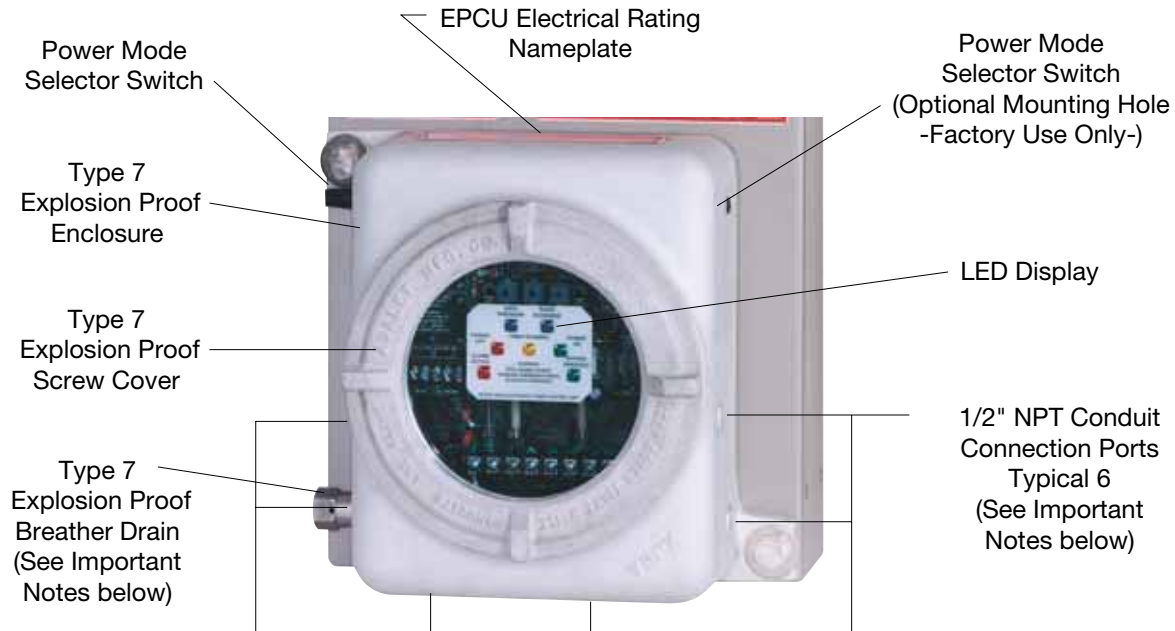

IMPORTANT NOTES

For proper moisture drainage of the Type 7 enclosure, the installer must 1) move the Type 7 breather drain to one of the bottom conduit entrances or 2) use drain seals on all conduit connected to the bottom two conduit entrances.

The Type 7 breather drain is not provided or required with PM configurations.

Top two conduit entrances will be dedicated for Intrinsic Safe wiring **ONLY** when the EPCU is supplied with Pepperl+Fuchs' optional ISB Intrinsic Safety Barriers.

EPCU LED Displays



Alarm Only



Alarm & Bypass

EPCU Power Rating

EPCU Electrical Power Rating Nameplate

The EPCU (Electrical Power Control Unit) of this Type "X" Rapid Exchange® purging system is offered in various styles. For proper installation and operation, begin by examining the EPCU Electrical Rating Nameplate to identify the System Input voltage and power requirements, enclosure power and alarm contact ratings and third party approval markings. Next, match the LED display of your EPCU with one of the displays shown on page 16. The EPCU LED Display will help identify the options featured on your system e.g. Normal Running mode or Conditional Bypass.

EPCU SERIAL NUMBER

REQUIRED WARNING STATEMENTS

MODEL 2000 ELECTRICAL POWER CONTROL UNIT
CAUTION: OPEN CIRCUIT BEFORE REMOVING COVER
ATTENTION: OUVRIR LE CIRCUIT AVANT D'ENLEVER LE COUVERCLE

SERIAL NO.	XXXXXX	INPUT VOLTAGE & POWER REQUIREMENTS
CSA Encl. 3 CLASS I, DIV. 1, Gr C&D CLASS II, DIV. 1, Gr E, F, G HAS UL & FM APPROVALS ONLY		ENCL POWER & ALARM CONTACTS ARE RATED 120/240 VAC, 20 AMPS <ul style="list-style-type: none"> ■ 120 SINGLE PHASE, 60 CYCLE, 1 AMP ■ 240 SINGLE PHASE, 50 CYCLE, 1 AMP

AREA CLASSIFICATION
 Defines the area classifications for which the EPCU is suitable for operation

EPCU INPUT POWER REQUIREMENTS
 Factory set at time of order

Assembled EPCU Electronics Module

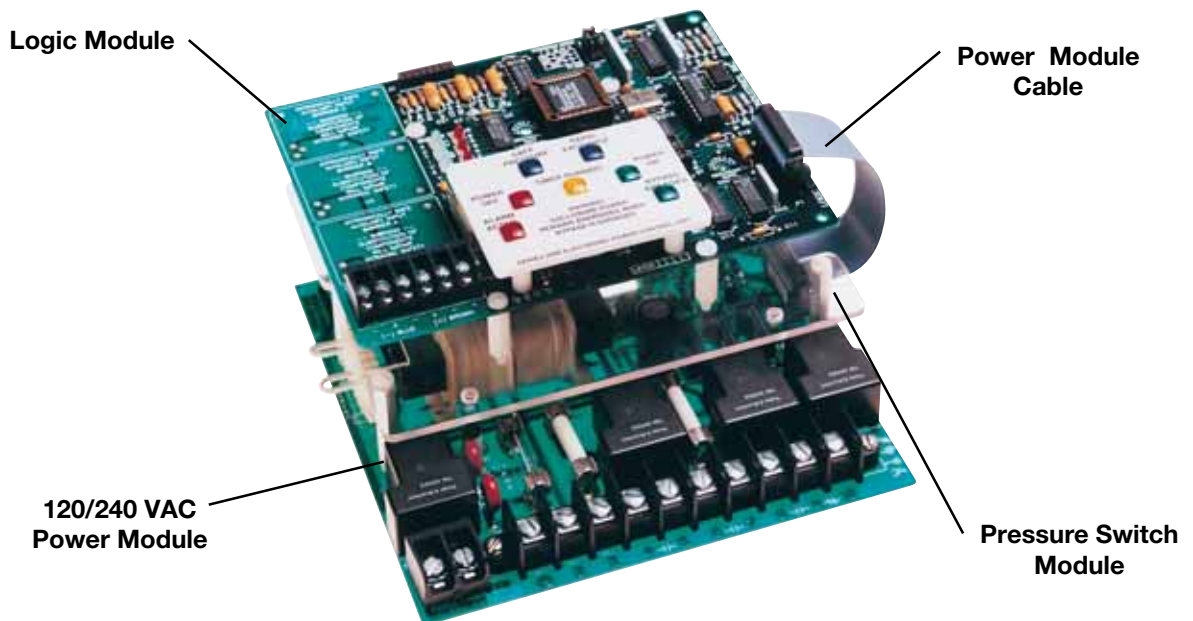

Electrical & Pneumatic Diagrams

LH, RH, TM, BM, WM & FM Configurations

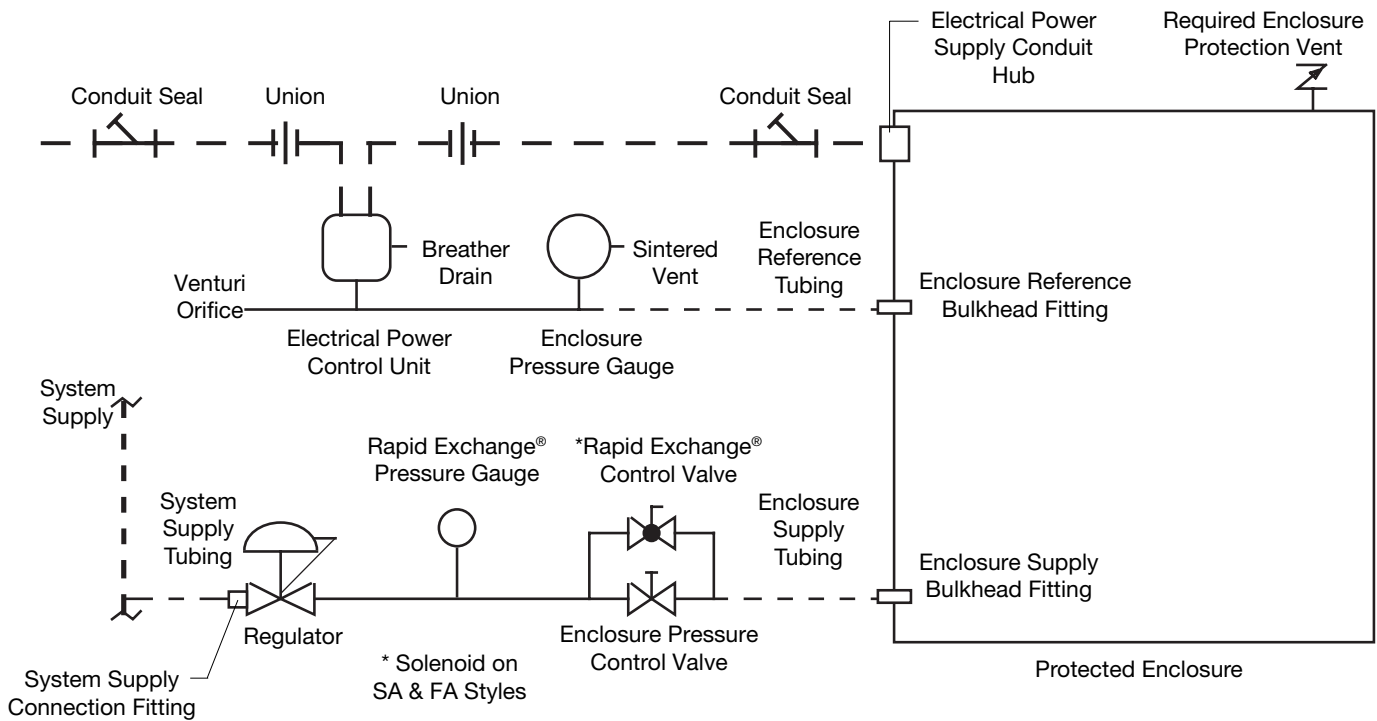

PM Configurations

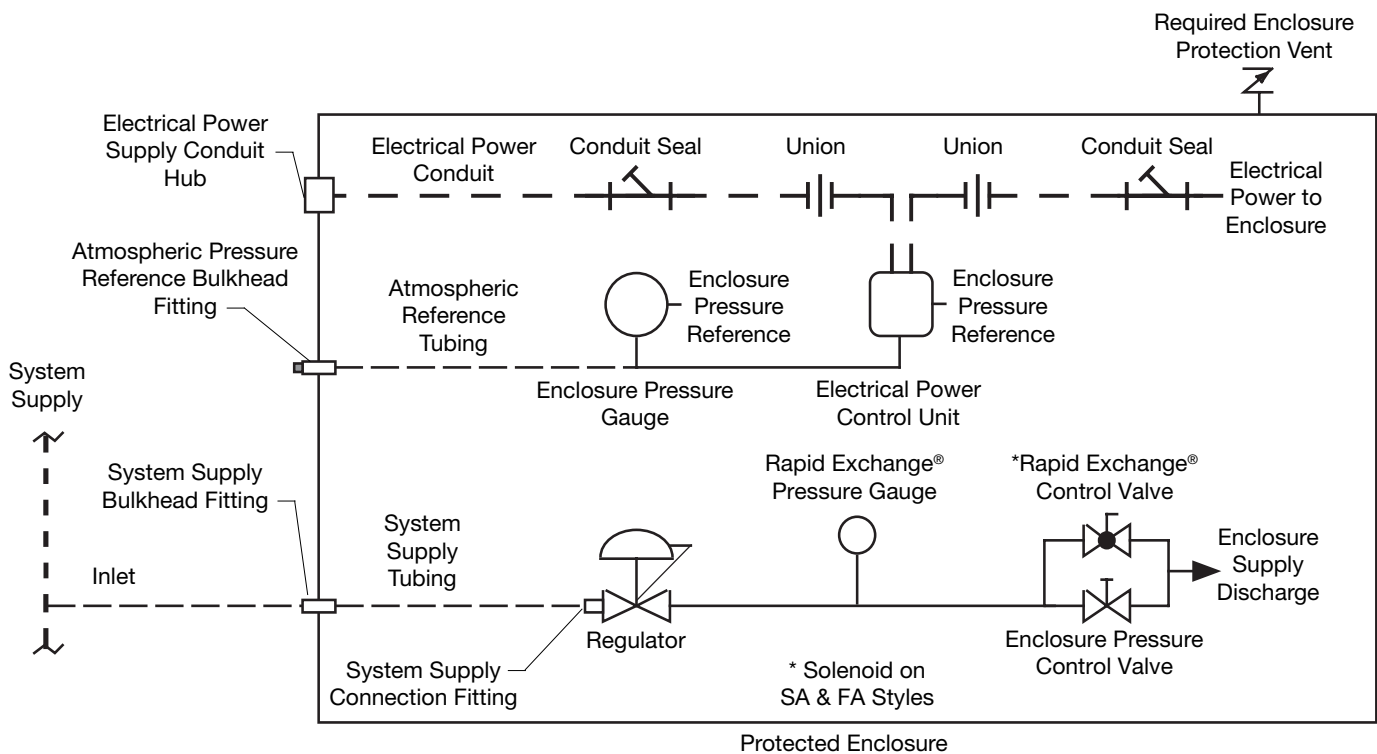

Conduit Installation

EPCU Electrical Conduit

Unplug the four unlabeled conduit entrances located on the sides and bottom of the EPCU enclosure (See page 16, "EPCU Layout" for conduit entrance layout).

The installer must mount the Type 7 drain fitting supplied with the system (except for PM configurations) in one of the bottom conduit entrances of the EPCU, or utilize drain seals on all conduit connected to the bottom two (2) conduit entrances of the EPCU.

Following the instructions listed below, install all conduit, fittings and seals (or drain seals if utilized) between the EPCU, alarm system (if utilized) and the protected enclosure(s). Plug all remaining EPCU conduit entrances.

1. Choose the location for the enclosure's electrical conduit connection(s) based on the requirements on page 15, "Electrical Supply Requirements".
2. Drill and deburr enclosure conduit fitting holes in the protected enclosure. Mount the fittings.
3. Determine appropriate route for the enclosure electrical enclosure and alarm signal conduit.
4. Measure, cut and thread conduit, check conduit fit to insure proper seating. Fully ream all conduit.
5. Install conduit and tighten all fittings to fitting manufacturers specifications. Secure conduit to appropriate structural supports as required.
6. Seal all conduit with an approved compound prior to operation of the protection system.

Optional Intrinsic Safety Barrier Conduit

Systems supplied with optional Intrinsic Safety Barriers (ISB) will be supplied with clearly labeled isolated conduit entries, a solid body wireway with snap cover and plexiglass wiring partitions. These accessories provide a fully isolated wiring path to the barrier wiring terminal located on the lower left corner of the EPCU Logic Module. All IS wiring must be isolated.

1. Choose the location for the enclosure's IS conduit connection(s) based on the requirements on page 15, "Electrical Supply Requirements".
2. Drill and deburr enclosure conduit fitting holes in the protected enclosure. Mount the fittings.
3. Determine appropriate route for the IS conduit.
4. Measure, cut and thread conduit, check conduit fit to insure proper seating. Fully ream all conduit.
5. Install conduit and tighten all fittings to fitting manufacturers specifications. Secure conduit to appropriate structural supports as required.
6. Seal all conduit with an approved compound prior to operation of the protection system.

EPCU Conduit Connection Parts

Fitting Kits Can Be FactoryFurnished

1. To connect enclosure power from the EPCU to the protected enclosure, one (1) LCK (L fitting Conduit Kit) or equivalent conduit elbow, coupling and seal fittings.
2. For EPCU to enclosure wiring connection with one (1) additional conduit connection path, one (1) TCK (T fitting Conduit Kit) or equivalent conduit tee, coupling and seal fittings.

IMPORTANT NOTE

Model LCK & TCK are offered primarily to OEM's attempting to achieve a "field ready" installation. In all cases, limited pipe fitting skills will be required. Pre-cut 150# galvanized steel pipe nipples can be acquired from local plumbing shops, but a hole saw or punch and wrenches are required to install kits.



**TCK "T" Fitting
Conduit Kit**



**LCK "L" Fitting
Conduit Kit**

Power Modules & Wiring Diagram

EPCU 120/240 VAC Power Module Layout

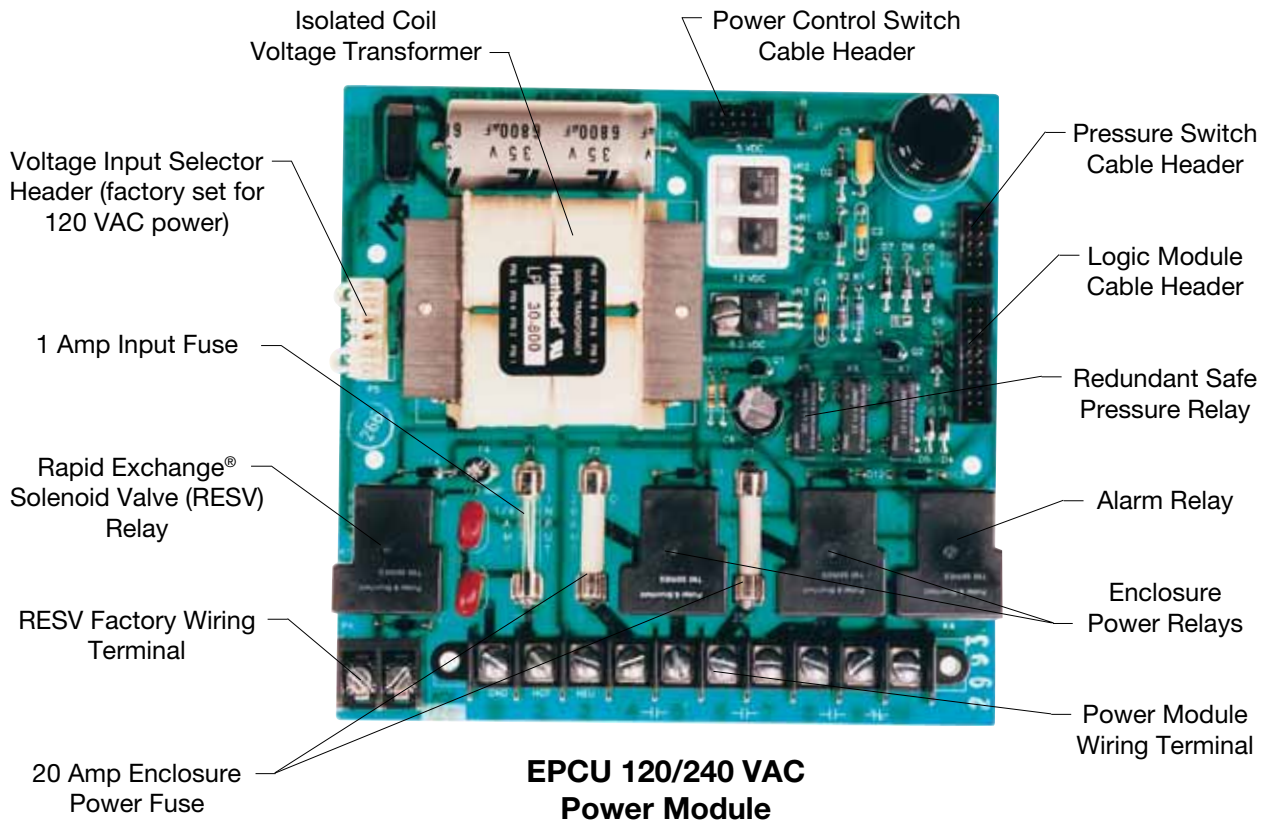

VAC & VDC Power Module Electrical Wiring Diagram

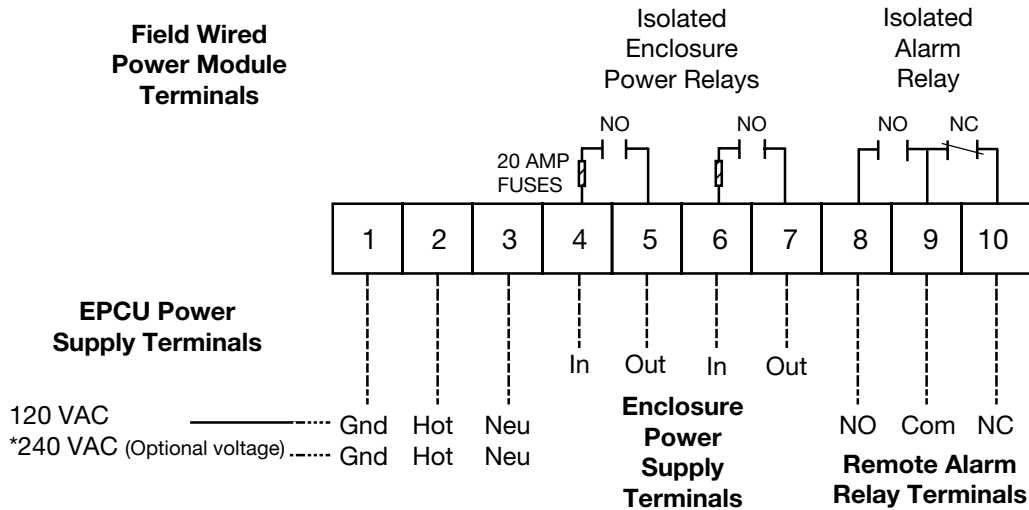

* European Single Phase 240 VAC only.

Power and alarm terminals are feed-thru dry switch contacts. Caution should be exercised to ensure that the EPCU wiring is properly connected.

All terminal connections to the EPCU should be wired with spade or round lugs.

Using 12 gauge maximum to 16 gauge minimum wire only, check EPCU power requirements (See page 15) and wire to the EPCU power source and alarm system (if utilized). Then route power source(s) through the EPCU power in and out terminals to all non-rated devices within the protected enclosure(s).

Logic Module & Barrier Wiring

EPCU Logic Module & Pressure Switch Module

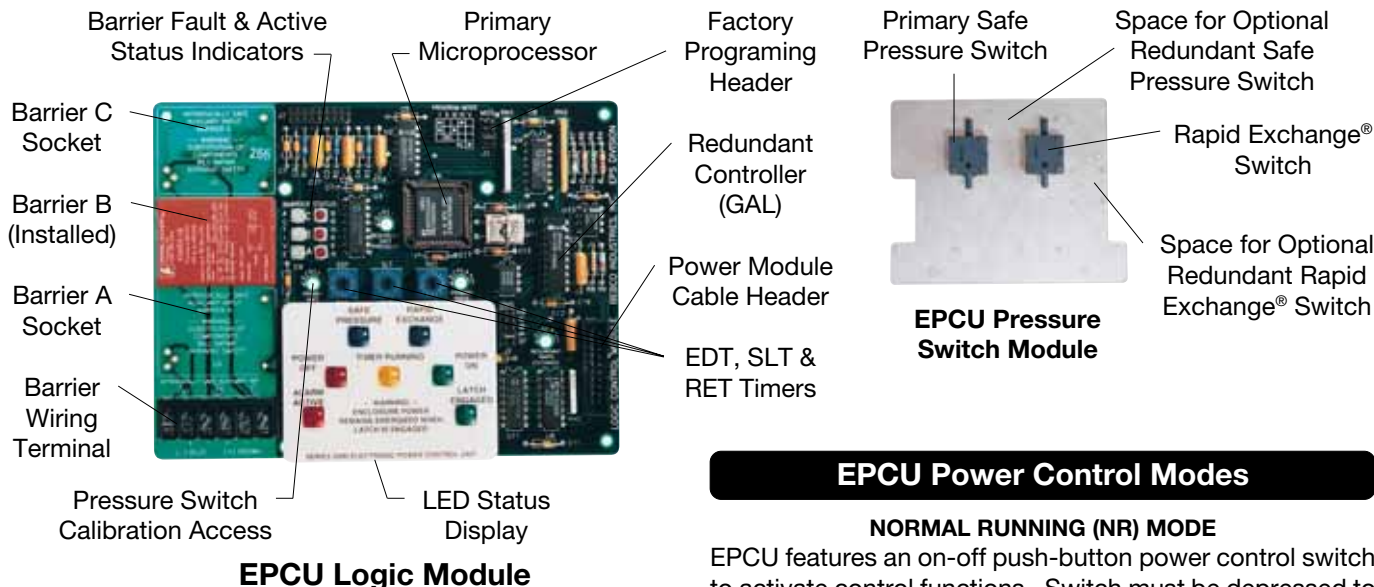

Optional ISB Wiring Requirements

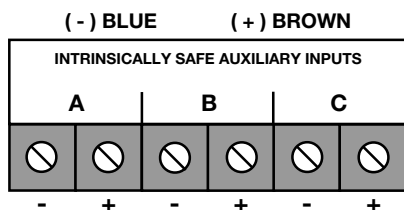

All optional intrinsic safety (IS) wiring must be isolated from all other electrical wiring using the dedicated IS conduit entrances and wireway of the EPCU, (See "Optional ISB Conduit Installation" on page 19 for more details). In addition, all wiring must be installed in accordance with the NEC and all relevant local and plant codes.

The ISB Intrinsic Safety Barriers are designed to function in conjunction with a customer furnished switch and SRM-4000 Switch Resistor Module, or an NJ...NAMUR Sensor. The customer supplied switch must have dry contacts which contain no inductance or capacitance.

The SRM-4000 Switch Resistor Module and the NJ...NAMUR Sensor are supplied with approximately ten (10) feet of wiring. Using 16 to 18 gauge shielded wire, the cable lengths can be extended to a maximum of 100 feet.

In all applications, the module of the Switch Resistor Module Cable must be installed as close to the customer supplied switch as possible for proper operation.

Wiring lugs are not recommended for Intrinsic Safety Barrier wiring connections.

See page 22 for barrier operation and factory programming.

EPCU Power Control Modes

NORMAL RUNNING (NR) MODE

EPCU features an on-off push-button power control switch to activate control functions. Switch must be depressed to initiate start-up. After completion of start-up, safe pressure must be lost or switch must be depressed to deenergize enclosure power relays.

CONDITIONAL BYPASS (CB) MODE

EPCU features an on-off-bypass power control switch to activate control functions. Switch must be set to "on" position to initiate start-up. After enclosure power is energized, safe pressure must be lost or switch must be set to "off" position to deenergize enclosure power. After enclosure power is energized, switch may be set to "bypass" position, to temporarily latch enclosure power relays. A flashing LED then indicates bypass engaged, and the enclosure can then be accessed without deenergizing power (performed under specific conditions). Following access, safe pressure must be reestablished to resume normal operation. At that time, the switch may be reset to the on position, without disruption of enclosure power. Alarm relay normally deenergizes only upon loss of safe pressure, but can be factory programmed to deenergize when bypass is engaged, if specified at time of order.

Barriers & Field Adjustments

Optional Intrinsic Safety Barriers Description

The EPCU Logic Module can accommodate up to three intrinsic safety barriers, to interact with remote devices and affect operation of the EPCU. The barriers are installed and programmed by the factory at time of order, and they are designed to function either in conjunction with a customer furnished switch and a Pepperl+Fuchs furnished resistor network cable, or a Pepperl+Fuchs furnished proximity detector. Each barrier develops a low power signal, to create a two wire closed loop circuit. Operational status of each barrier is indicated by a green LED to show active (closed switch) status, and by a red LED to show faulted (line breakage) cable status. All barriers can be reprogrammed to duplicate other barrier functions as required, upon specific request.

Optional ISB Factory Programming

Barrier A Function - when switch opens

Disables start-up cycle
Deenergizes enclosure power and alarm relay
Functions parallel to safe pressure switch

Barrier B Function - when switch opens

Disables Rapid Exchange® cycle
Functions parallel to Rapid Exchange® pressure switch

Barrier C Function - when switch closes

Energizes Rapid Exchange® solenoid valve relay

LED Display Indicators

Power Off: Enclosure Power Relays Deenergized
Power On: Enclosure Power Relays Energized
Safe Pressure: Enclosure Pressure > 0.15" or 0.50" w.c.
Rapid Exchange: Enclosure Pressure > 2.0" w.c.
Timer Running: Rapid Exchange® Timer Active
Alarm Active: Enclosure Pressure < 0.15" w.c.
Bypass Engaged: Control Bypass Active - CB Mode

Field Adjustable Timer Functions

EDT (Exchange Delay Timer) (FA Style only) provides a time delay to prevent Rapid Exchange® solenoid valve from energizing until safe pressure can be stabilized.

SLT (Solenoid Latching Timer) (FA Style only) provides a time delay to keep the Rapid Exchange® solenoid valve energized until Rapid Exchange® pressure is detected. If the pressure is not detected by completion of the time cycle, the EPCU will reset.

RET (Rapid Exchange® Timer) provides a time delay after Rapid Exchange® pressure is detected, to allow four volume exchanges (ten volumes for motors) prior to energizing the enclosure power relays. If Rapid Exchange® pressure is lost or interrupted during time delay cycle, the EPCU will reset.

EDT, SLT & RET Timer Settings

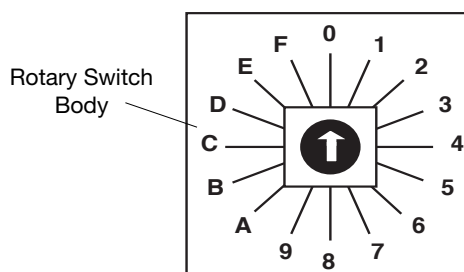

EDT & SLT Timer

POSITION	TIME IN SECONDS
0	5
1	10
2	15
3	20
4	25
5	30
6	35
7	40
8	45
9	50
A	55
B	60
C	65
D	70
E	75
F	80

RET Timer

POSITION	TIME IN MINUTES
0	5
1	10
2	15
3	20
4	25
5	30
6	35
7	40
8	45
9	50
A	55
B	60
C	65
D	70
E	75
F	80

NOTE: Power must be removed from the EPCU via the local disconnect for approximately 10 seconds for timer adjustments to reset.

Set-up Procedure

IMPORTANT NOTES

Regardless of any condition, the Type X Rapid Exchange® System is designed to automatically withhold power to the protected enclosure while inducing Rapid Exchange®, for at least five (5) minutes. Normal exchange times should be doubled if large obstructions block inert gas flow.

To test the vent's operation, gently prod the vent flapper open with a soft pointed object, (example: eraser end of a pencil) ensuring that the vent valve works freely. On vertically configured vents, this can be accomplished from within the protected enclosure. Side mounted -90 configured vents can be tested by removing the pipe plug at the bottom of the mounting tee. Multiple operations require only one test per day if enclosure is not opened or left unattended.

The volume exchange rate is based on a four (4) enclosure volume exchange. Multiply the required exchange time by 2.5 for applications requiring a ten (10) volume exchange (motors).

The Start-Up Instruction Nameplate Exchange Time Slot will feature the standard factor for this system "ONE MINUTE PER CUBIC FOOT", but the unit may feature a set of direct factor nameplates with self-adhesive backing such as "TEN MINUTES", for application to the start-up instructions, dependent on how the system was specified and purchased. Field modification of this nameplate, to show a direct factor, is acceptable as noted above if the method used to mark the nameplate does not deface the instructions listed. Materials used for the marking must be indelible and withstand prevailing environmental conditions.

Model 2002 Rapid Exchange® Purging Set-up

1. Close the Enclosure Pressure Control Valve (all Styles) and Rapid Exchange® Control Valve (STD Style only) fully by turning clockwise (CW).
2. Connect the inert gas supply to the System Supply Inlet and set the Rapid Exchange® Pressure Gauge to 60 psi.
3. Temporarily connect a 0-5 inch water column pressure gauge or manometer to the protected enclosure.
4. Check operation of Enclosure Protection Vent as detailed above. (see "Important Notes")
5. Seal enclosure(s) and adjust Enclosure Pressure Control Valve by opening slowly counterclockwise (CCW) to set a "Safe" pressure on the Enclosure Pressure Gauge.
Note: If pressure setting is difficult to stabilize or set, (see page 26, "Trouble-Shooting Procedures").
6. **STD Styles** - Open Rapid Exchange® Control Valve fully by turning 90° CCW and quickly ensure the Enclosure Protection Vent opens.
SA & FA Styles - With the aid of an assistant having two 1/2" combination wrenches on hand, place left hand on system mounting plate and pull Rapid Exchange® Manual Operator firmly with right hand and quickly ensure the Enclosure Protection Vent opens. If Enclosure Protection Vent operates properly, have assistant carefully place the open end of both wrenches behind handle to hold the manual operator in the out position temporarily.
Note: The Enclosure Pressure Gauge should move quickly off scale to the right, this is normal for all Rapid Exchange® purging systems.
7. Readjust the regulator to 60 psi minimum, while inducing Rapid Exchange®, the test gauge should then read approximately 2 inches of pressure and should not fluctuate. (insufficient enclosure pressure will cause the Enclosure Protection Vent to "shuttle") **DO NOT** exceed 5 inches of pressure within the protected enclosure.
8. Close Enclosure Pressure Control Valve and Rapid Exchange® Control Valve (STD Styles) or Remove the two 1/2" combination wrenches from behind the handle.
Note: The Rapid Exchange® Pressure Gauge may now indicate a higher set pressure than was originally set, this is normal for all Rapid Exchange® purging systems.
9. Set RET timer (see page 21 for timer location and settings) for required exchange time based on System exchange rate of ONE MINUTE PER CUBIC FOOT, five (5) minute minimum.
10. Install and tighten cover of EPCU. Ensure the conduit is sealed with approved compounds.
11. Depress the On-Off push-button (NR mode) or turn selector switch to the On position (CB mode). Each LED should illuminate fully for two seconds (self test), then all LEDs should turn off except Power Off (solid red) and Alarm Activated (flashing red) LEDs.
12. Turn Enclosure Pressure Control Valve slowly CW to set the Enclosure Pressure Indicator to a "Safe" 0.25 inch pressure. The Safe Pressure LED should be on, the Alarm Active LED should turn off. Check for a 0.10 to 0.15 inch trip point by slowly stroking the indicator from 0.10 to 0.25 inch readings. The Safe Pressure and Alarm Active LEDs should turn on and off when the indicator reads between 0.10 and 0.15 inches.
Note: FA Style only - Rapid Exchange® Solenoid Valve will engage automatically upon time out of the EDT Timer. Should the operator require additional time to set a stable Safe Pressure on the enclosure pressure indicator, reset the EDT timer setting as described on page 22.

Set-Up Procedure continued on page 24.

Set-up Procedure (cont.)

Model 2002 Rapid Exchange® Purging Set-up

13. **STD Style** - Open Rapid Exchange® Control Valve fully by turning 90° CCW and quickly ensure the Enclosure Protection Vent opens. The Rapid Exchange® and Timer Active LEDs should be on. Check for trip point by turning Rapid Exchange® Control Valve on and off. The Rapid Exchange® and Timer Running LEDs should turn on and off as exchange is engaged and disengaged, without disturbing the status of the Safe Pressure LED.

SA Style - Place left hand on system mounting plate and pull Rapid Exchange® Manual Operator firmly with right hand, until solenoid latches (to hold valve open automatically) then quickly ensure the Enclosure Protection Vent opens. The Rapid Exchange® and Timer Active LEDs should be on. Check for trip point by turning EPCU power switch off and on (to reset unit). The Rapid Exchange® and Timer Running LEDs should not turn on until valve is more than half open. Allow System to run through RET timer cycle and watch for solenoid to disengage. The valve should be able to shut off without disturbing the status of the Safe Pressure LED.

FA Style - Rapid Exchange® Solenoid Valve will engage automatically upon time out of the EDT Timer, then quickly ensure the Enclosure Protection Vent opens. The Rapid Exchange® and Timer Active LEDs should be on and SLT Timer will be running. Check for trip point by turning EPCU power switch off and on (to reset unit). The Rapid Exchange® and Timer Running LEDs should not turn on until valve is more than half open. Starting again, allow System to run through EDT, SLT and RET timer cycles and watch for solenoid to disengage. The valve should be able to shut off without disturbing the status of the Safe Pressure LED.

14. Having ensured that the Safe Pressure and Timer Running LEDs are functioning properly, Operating Procedures located on page 25 may now be followed to step through a complete start up cycle, ensuring that the System functions normally during all phases of operation.

15. Cease testing and remove test equipment .

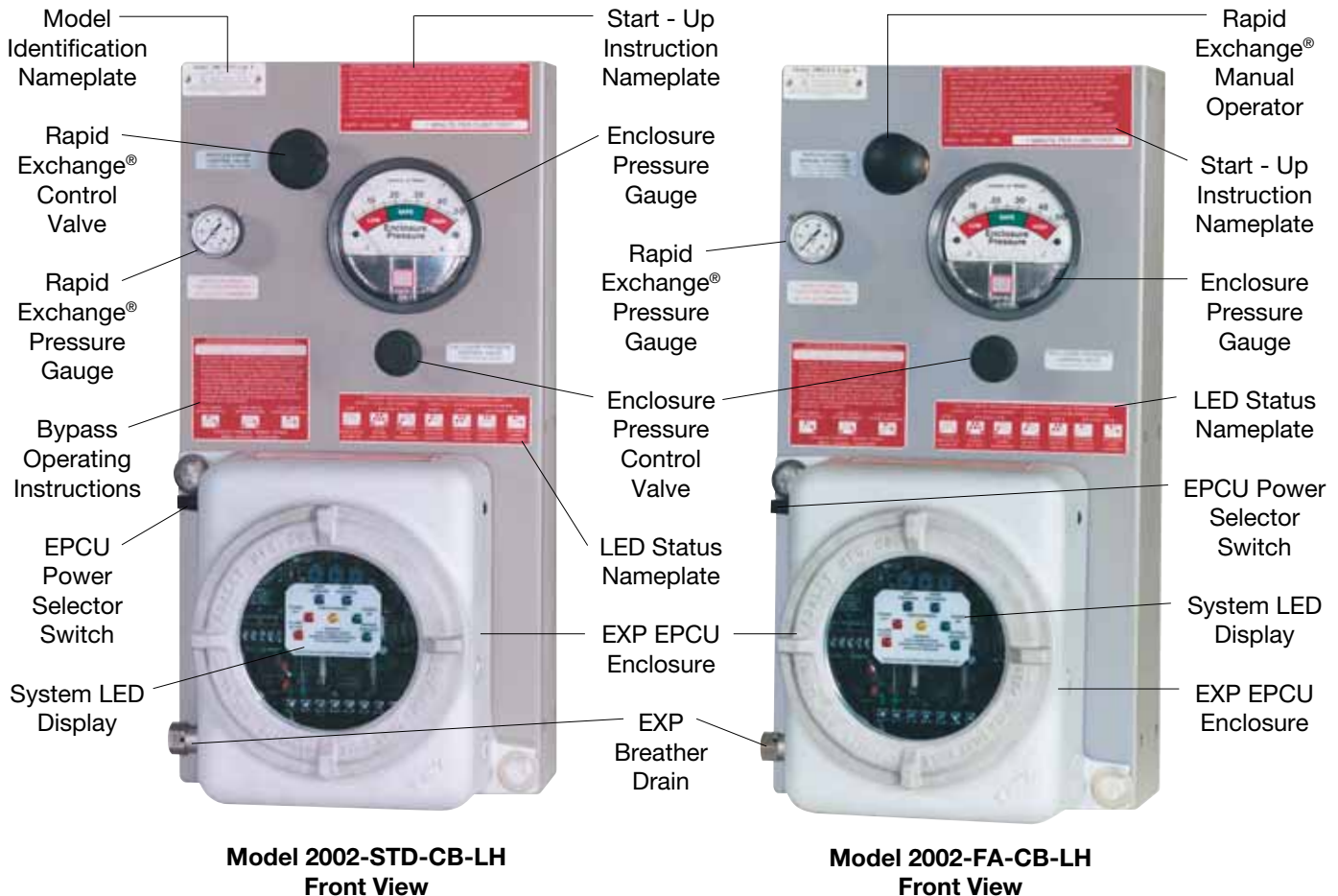

Operating Sequence

WARNING

Do not exceed a "Safe" pressure with the Enclosure Pressure Control Valve.

Operators must follow step-by-step sequence of the Start-Up Instructions Nameplate on the Protection System.

Do not use the Bypass Modes without first securing a "Hot Work" permit.

Never leave the system unattended in Bypass Modes.

Rapid Exchange® Purging Operation

With the inert gas supply on, RET Timer set properly (STD and SA Styles), EDT, SLT and RET Timers set properly (FA Styles), EPCU power and alarm system energized (if utilized) .

1. Carefully read Start-Up Instruction Nameplate on system.
2. Check operation of the Enclosure Protection Vent, EPV-2, opening it manually several times (see page 23, "Helpful Hint").
3. Seal protected enclosure(s).
4. Depress the On-Off push-button (NR mode) or turn selector switch to the On position (CB mode). Each LED should illuminate fully for two seconds as a self test, then all LEDs should turn off except Power Off (solid red) and Alarm Activated (flashing red) LEDs.
5. Turn Enclosure Pressure Control Valve slowly CCW to set the Enclosure Pressure Indicator to a "Safe" 0.25 inch pressure. The Safe Pressure LED should be on, the Alarm Active LED should turn off.
6. **STD Style** - Open Rapid Exchange® Control Valve **fully** by turning 90° CCW and quickly ensure the Enclosure Protection Vent opens. The Rapid Exchange® and Timer Active LEDs should turn on.

SA Style - Place left hand on system mounting plate and pull Rapid Exchange® Manual Operator firmly with right hand, until solenoid latches (to hold valve open automatically) then quickly ensure the Enclosure Protection Vent opens. The Rapid Exchange® and Timer Active LEDs should turn on.

FA Style - Rapid Exchange® Solenoid Valve will engage automatically upon time out of the EDT Timer, then quickly ensure the Enclosure Protection Vent opens. The Rapid Exchange® and Timer Active LEDs should be on and SLT Timer will be running.

Note: On all Styles, if the Safe Pressure or Timer Running LEDs blink on and off or "flicker" during this cycle, EPCU will reset RET timer.

7. Standby until the EPCU RET Timer completes the timing cycle and energizes enclosure power. Safe Pressure LED should stay on, Timer Running LED should turn off and Power On LED should turn on.

8. **STD Style** - Close Rapid Exchange® Control Valve fully by turning 90° CW. The Rapid Exchange® and Timer Active LEDs should be off.

SA & FA Styles - After completion of the RET timing cycle, Timmer Running LED should turn off and Power on LED should turn on. At the same time, the Rapid Exchange® Solenoid Valve should deenergize and the Rapid Exchange® LED should turn off.

9. Ensure the Protection System Enclosure Pressure Indicator maintains a "Safe" 0.25 inch pressure for one (1) minute. Readjust Enclosure Pressure Control Valve if required.

10. If "Safe" 0.25 inch pressure is lost, the EPCU will deenergize enclosure power and activate alarm system (if utilized).

Trouble - Shooting Procedures

Problem or Fault	Possible Causes	Corrective Action
Enclosure pressure control valve will not hold a safe .25 inch pressure.	Leakage around gasketing, covers, seams, piping and tubing connections, conduit connections and electrical conduit seals of the enclosure.	Tighten enclosure latches: Where tightening is not feasible, and gasketing materials are not practical, holes or gaps can be closed with silicone sealant applied from inside the protected enclosure.
Enclosure pressure indicator reading is difficult to stabilize.	Insufficient enclosure leakage or opening of the venturi orifice is crimped too small.	Remove the orifice, cut off the crimped end and ream the tube, then rerimp and reinstall the tube to note effect. As tube is shortened, reamed, and rerimped, sensitivity decreases, allowing easier adjustment of setpoint on the enclosure.
Enclosure Protection Vent "Shuttles" or Flutters"	Excessive leakage from protected enclosure. Insufficient protective gas supply header pressure.	Check all points above and verify a minimum 60 psi injection pressure reading on the Rapid Exchange® Pressure Indicator during Rapid Exchange®. With a 0.0" - 5" water column test gauge installed properly (see "Set-Up Procedures" page 23), slowly increase the Rapid Exchange® Injection pressure with the Rapid Exchange® valve engaged until this effect is eliminated. Do not exceed 3 inches of pressure within the protected enclosure.
Enclosure Pressure Indicator reads a "Safe" pressure but the Safe Pressure LED is not illuminated.	Conduit seal between EPCU and protected enclosure is not poured or is leaking pressure back into the EPCU. EPCU breather drain is clogged (all systems except PM configurations). Safe Pressure switch is out of calibration.	With area positively known to be non-hazardous, remove screw cover of the EPCU and attempt a complete start-up procedure. If the system works properly, check enclosure power conduit seal for leakage and the EPCU breather drain for blockage. If the system does not operate properly, calibrate the Safe Pressure switch. Calibrate by slowly adjusting CW to decrease the setpoint, and CCW to raise the setpoint. (Do not attempt to calibrate the switch until all efforts to make the switch respond properly have failed)
Rapid Exchange® LED does not illuminate when Rapid Exchange® is engaged. FA Style only - The Rapid Exchange® solenoid continues to cycle without starting the RET timer.	Conduit seal between EPCU and protected enclosure is not poured or is leaking pressure back into the EPCU. EPCU breather drain is clogged (all systems except PM configurations). Rapid Exchange® Pressure switch is out of calibration.	With area positively known to be non-hazardous, remove screw cover of the EPCU and attempt a complete start-up procedure. If the system works properly, check enclosure power conduit seal for leakage and the EPCU breather drain for blockage. If the system does not operate properly, calibrate the Rapid Exchange® Pressure switch. With Rapid Exchange® engaged, calibrate by slowly adjusting counterclockwise to decrease the setpoint, and clockwise to raise the setpoint. (Do not attempt to calibrate the switch until all efforts to make the switch respond properly have failed)
Problems persists, or if the system does not appear to be operating properly.	Persisting problems.	Contact Pepperl+Fuchs Applications/ Customer Service Department at (330) 486-0002 for more information.

Warranty Terms and Conditions

PEPPERL+FUCHS STANDARD 24-MONTH WARRANTY

1. Limited Warranty. Pepperl + Fuchs, Inc. ("P+F") warrants Purge Units and components for Purge Units manufactured by P+F ("Product" or "Products") to be free from defects in material and workmanship under Normal Use for a period of twenty-four (24) months from the date of shipment of such Products from P+F's warehouse or place of manufacture (or from P+F's authorized representative or distributor). Only the original purchaser of such Products (the "Customer") shall be entitled to the benefit of the foregoing Limited Warranty. No representative, agent or salesman of P+F is authorized to give or provide any warranty or make any representation contrary to or in addition to the foregoing Limited Warranty.
2. Inspection and Claims. Customer must inspect and test all Products upon receipt. All claims under the Limited Warranty provided herein must be made within thirty (30) days of the discovery of the defect. Customer must obtain shipping instructions from P+F prior to returning any Product, which Product must be returned at Customer's expense in accordance with P+F's instructions.
3. Limitations and Exclusions. "Normal Use" shall mean use and operation within rated capacities, at the correct voltage, and with any required maintenance as provided in the applicable P+F Operating Manuals. The Limited Warranty provided herein does not apply to (i) any Products which have been altered or modified in any way or disassembled by the Customer or anyone else, (ii) any Products which have been subject to misuse, negligence or accident, or improperly installed, changed, substituted or replaced, (iii) any part or component not manufactured by P+F, or (iv) any part or component that is subject to wear or consumption. For parts or components not manufactured by P+F, the Customer or any other user or owner shall have only the warranty provided by the manufacturer of such part or component. The Limited Warranty set forth herein is also subject to the following:
 - (1) The Limited Warranty is limited to electronic and mechanical performance only, as expressly detailed in the product specifications, and does not apply to cosmetic appearance;
 - (2) The Limited Warranty shall not apply to any cables attached to, or integrated with, any Products.
 - (3) The Limited Warranty shall not apply to any Products which are stored, or utilized, in harsh environmental or electrical conditions outside P+F's written specifications.

THE LIMITED WARRANTY SET FORTH HEREIN IS THE ONLY WARRANTY MADE BY P+F WITH RESPECT TO THE PRODUCTS. IT IS EXPRESSLY AGREED AND UNDERSTOOD THAT P+F MAKES NO WARRANTY OF MERCHANTABILITY OR FITNESS FOR A PARTICULAR PURPOSE. EXCEPT FOR THE LIMITED WARRANTY SET FORTH HEREIN, THERE IS NO OTHER WARRANTY, EXPRESS, IMPLIED OR STATUTORY; AND THERE IS NO AFFIRMATION OF FACT OR PROMISE BY P+F WITH REFERENCE TO THE PRODUCTS. IN NO EVENT SHALL P+F BE LIABLE FOR ACTUAL OR ANTICIPATED LOST PROFITS OR FOR INCIDENTAL OR CONSEQUENTIAL OR PUNITIVE DAMAGES OR FOR DAMAGES RESULTING FROM BUSINESS INTERRUPTION, OR INJURY OR DEATH OF PERSONS, OR INJURY TO PROPERTY. P+F'S LIABILITY ON ANY CLAIM OF ANY KIND ARISING OUT OF, CONNECTED WITH OR RESULTING FROM THE DESIGN, MANUFACTURE, SALE, REPAIR OR OPERATION OF A PRODUCT, SHALL NOT EXCEED THE PRICE ALLOCABLE TO THAT PRODUCT OR THE PART THEREOF WHICH GIVES RISE TO THE CLAIM. THE REMEDY SET FORTH IN THIS LIMITED WARRANTY CONSTITUTES THE SOLE AND EXCLUSIVE REMEDY OF THE CUSTOMER. P+F SHALL NOT BE LIABLE FOR PENALTIES OF ANY DESCRIPTION.

4. Limitation of Remedies. In the event of P+F's liability, whether on this Limited Warranty or based on contract, tort (including, but not limited to, negligence and strict liability) or otherwise, Customer's sole and exclusive remedy will be limited to, at P+F's option, the repair or replacement (f/o/b P+F's place of manufacture) by P+F of any non-conforming items for which claim is made by Customer in accordance with paragraph 2, or the repayment of the portion of the purchase price paid by Customer attributable to the non-conforming item.
5. Responsibility of Customer: Safety and Protection Precautions. P+F takes great care to design and build reliable and dependable Products; however, some Products can fail eventually. Customer must take precautions to design its equipment to prevent property damage and personal injury in the unlikely event of a failure. AS A MATTER OF POLICY, P+F DOES NOT RECOMMEND THE INSTALLATION OF PRODUCTS AS THE SOLE DEVICE FOR THE PROTECTION OF PERSONNEL OR PROPERTY AND, THEREFORE, THE CUSTOMER SHOULD BUILD IN REDUNDANCY OR DUAL CONTROL USING APPROVED SAFETY DEVICES FOR THESE APPLICATIONS.
6. Conflicts. In the event there is any conflict between the provisions of this Limited Warranty and any provisions contained in any orders, offers, acceptances or other writings or statements provided or made by Customer to P+F, the provisions of this Limited Warranty shall prevail, and the contract between P+F and the Customer shall be deemed formed only upon the provisions set forth in this Limited Warranty, and any additional or conflicting provision inserted by Customer shall be of no force or effect.

CUSTOMER NOTES



CUSTOMER NOTES



SYSTEMS IDENTIFICATION & APPLICATION INFORMATION

Date of Installation _____

Unit Serial # _____

Item _____

Customer P.O.# _____

Customer Project# _____

Service _____

Type _____

Features _____

Application _____

NOTES: _____

