

# TCA! Setup Sheet

Driver: WALTER HENDERSON Date: 9/25/05  
 Track: LAS VEGAS STARDUST Indoor  Outdoor   
 Event: INTERNATIONAL INDOOR CHAMPIONSHIP  
 Conditions: CARPET WITH FOAM TIRES

## Front Suspension

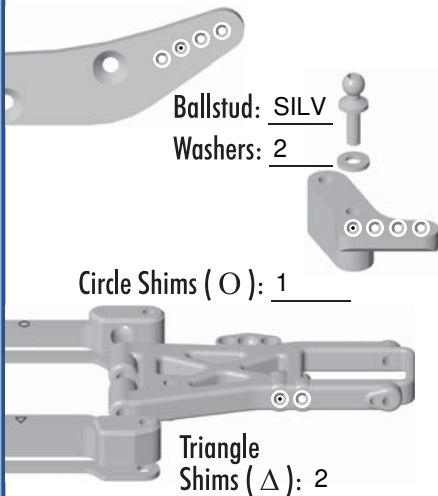

### Front Upright



### Front Shocks

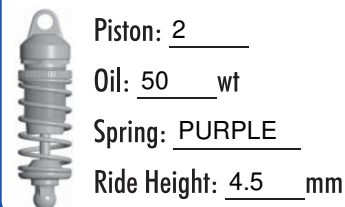

### Steering Rack

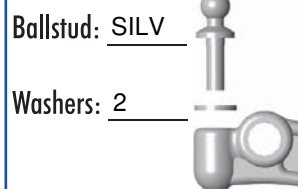

### Arm Spacing



### Anti-Roll Bar



### Alignment

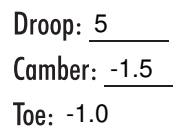

### Front Diff

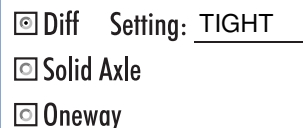

Notes: [ARM SPACING ABOVE: SECOND SPOT FROM BOTTOM S/B BLANK]

## Rear Suspension

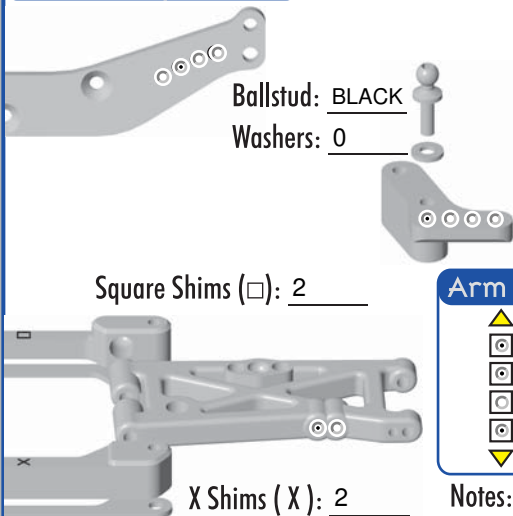

### Rear Upright



### Rear Shocks

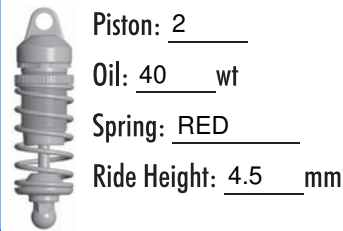

### Arm Spacing



### Anti-Roll Bar



### Alignment

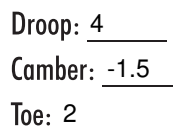

Notes: \_\_\_\_\_

## Turning Diameter

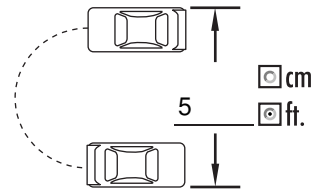

## Chassis Stiffness

Standoffs  Spine Plate

Notes: \_\_\_\_\_  
 \_\_\_\_\_  
 \_\_\_\_\_

## Tires

### Front Tires

Compound: JACO DBL PINK/ORANGE  
 Insert: \_\_\_\_\_  
 Wheel: \_\_\_\_\_  
 Tire Diameter: 2.18"  
 Traction Compound: JACK THE GRIPPER  
 Application - **Front**: 3/4  
 Notes: \_\_\_\_\_

### Rear Tires

Compound: JACO DBL PINK  
 Insert: \_\_\_\_\_  
 Wheel: \_\_\_\_\_  
 Tire Diameter: 2.18"  
 Application - **Rear**: FULL  
 Notes: \_\_\_\_\_

## Electronics

Motor: REEDY 7X1 Gear: 100 t/ 28 t  
 Motor Brush: 777 Motor Spring: BLACK  
 Motor Timing: 12  
 Battery: REEDY IB3800 Position: --  
 ESC: LRP QC2 Mode: 2  
 Drag Brake: 2 Initial Brake: 2

## Body & Wing

Sidedams  Spillplates  
 Body: PROTOFORM G6 Wing: STOCK  
 Notes: \_\_\_\_\_

## Race Comments

Main: \_\_\_\_\_ Qualifying Position: \_\_\_\_\_ Finish: \_\_\_\_\_  
 Notes: \_\_\_\_\_