

GENERAL NOTES:

- DIMENSIONS**
  - SHOWN IN INCHES W/ MM EQUIVALENTS IN BRACKETS
  - OVERALL LENGTH = CENTERS + FLOAT LENGTH + MATING FLANGE THICKNESS + 8.125" [206]
- OPERATING CONDITIONS**
  - MAX PRESSURE, MAX TEMPERATURE, & MIN SPECIFIC GRAVITY REQUIRED FOR PROPER GAGE DESIGN
- PART NUMBER**
  - CONSULT "MAGNicator® II MAGNETIC LIQUID LEVEL INDICATION PRODUCTS" (BULLETIN M100.01) FOR COMPLETE PART NUMBER DETAILS & LIST OF AVAILABLE OPTIONS
- STANDPIPE SIZE**
  - 2 1/2" [65] SCH. 40 (STANDARD) MAGNicator STANDPIPE / 3" [80] SCH. 40 (STANDARD) BY-PASS STANDPIPE
  - CONSULT FACTORY FOR OPTIONAL STANDPIPE SIZE AND/OR SCHEDULE (DEPENDENT ON OPERATING CONDITIONS)
- MATERIALS OF CONSTRUCTION**
  - 304/304LSS W/ CS TRIM (CAP, FLANGES, BOLTING, & PLUGS) (STANDARD)
  - 316/316LSS W/ CS TRIM (CAP, FLANGES, BOLTING, & PLUGS) (STANDARD)
  - ALL 304/304LSS (316SS BOLTING) (STANDARD)
  - ALL 316/316LSS (316SS BOLTING) (STANDARD)
  - CONSULT "MAGNicator® II MAGNETIC LIQUID LEVEL INDICATION PRODUCTS" (BULLETIN M100.01) FOR A COMPLETE LIST OF AVAILABLE MATERIALS
- FLOAT MATERIALS**
  - 316LSS (STANDARD)
  - TITANIUM (STANDARD)
  - MONEL 400
  - HASTELLOY C276
- FLOAT LENGTHS**
  - 12" [305] (STANDARD)
  - 17" [432] (STANDARD)
  - 22" [559] (STANDARD)
  - LENGTHS DEPENDENT ON OPERATING CONDITIONS
  - CONSULT FACTORY FOR CUSTOM LENGTHS
- GASKET MATERIALS**
  - FLEXITALLIC "CGI" (OR EQUAL) SPIRAL-WOUND (STANDARD) W/ CS OUTER RING, 304 OR 316SS INNER RING, & GRAPHITE FILLER
  - CONSULT FACTORY FOR OPTIONAL GASKET MATERIALS
- PROCESS CONNECTIONS**
  - 1/2" [15] THRU 1" [25] FSW & MSW (STANDARD)
  - 1 1/2" [40] THRU 6" [150] FSW & MSW AVAILABLE ON REQUEST (REQUIRE FITTINGS THAT INCREASE SECTION A-A DIMENSION SHOWN)
  - (2) SIDE CONNECTIONS (STANDARD)
  - (2+) SIDE CONNECTIONS AVAILABLE ON REQUEST
- VENT / DRAIN CONNECTIONS**
  - 1/2" [15] FNPT (SHOWN) (STANDARD)
  - 1/2" [15] THRU 1 1/2" [40] FNPT, MNPT, FSW, & MSW
  - 1/2" [15] TO 3" [80] RAISED-FACE ANSI/ASME & DIN FLANGED
- INDICATION**
  - YELLOW / BLACK FLAGS IN ALUMINUM HOUSING (SHOWN) (STANDARD)
  - HERMETICALLY-SEALED FLAGS IN POLYCARBONATE TUBE W/ 316SS FRAME (BULLETIN M100.110)
  - HERMETICALLY-SEALED FLAGS IN GLASS TUBE W/ 316SS FRAME (BULLETIN M100.110)
  - NIGHTSTAR™ (ILLUMINATED FLAGS) (120 OR 240 VAC) (BULLETIN M100.140)
  - LEVELSTAR™ (LED ILLUMINATOR) (120 OR 240 VAC) (BULLETIN M100.120)
- SCALES**
  - FEET / INCHES (SHOWN) (STANDARD)
  - METER / CENTIMETER
  - PERCENT
  - CONSULT FACTORY FOR SPECIAL SCALES
- POINT LEVEL SWITCHES**
  - SAS-16 TRI-MAGNET (BULLETIN M100.27)
  - RS-2 (SPDT) HERMETICALLY-SEALED REED (BULLETIN M100.20)
  - RS-2/2 (DPDT) HERMETICALLY-SEALED REED (BULLETIN M100.20)
- 4-20mA TRANSMITTERS**
  - GUIDED WAVE RADAR
  - MT11-4200 MAGNETOSTRICTIVE (BULLETIN M100.23)
  - RST2 REED SWITCH (BULLETIN M100.22)

OPTION	A
W/O STEAM COMPENSATION	8" [203]
W/ STEAM COMPENSATION	18" [457]

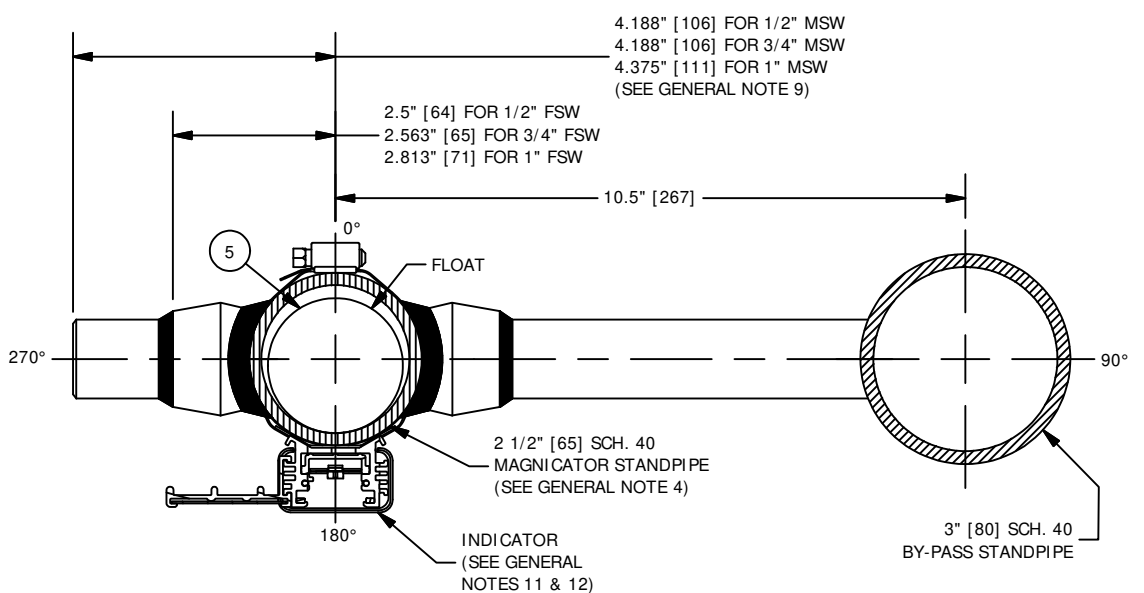
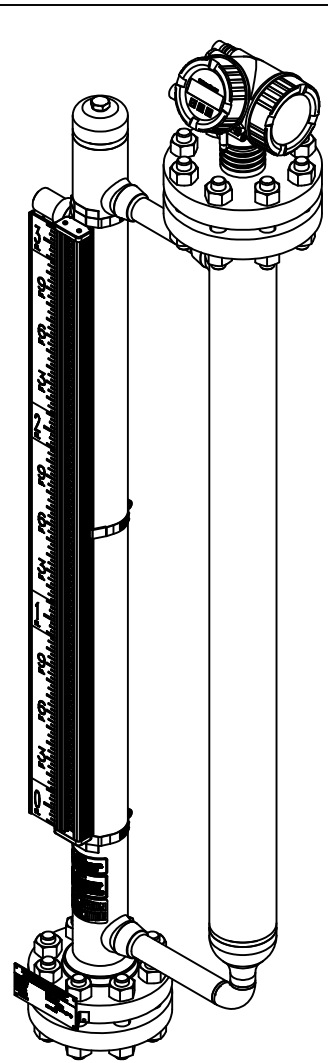
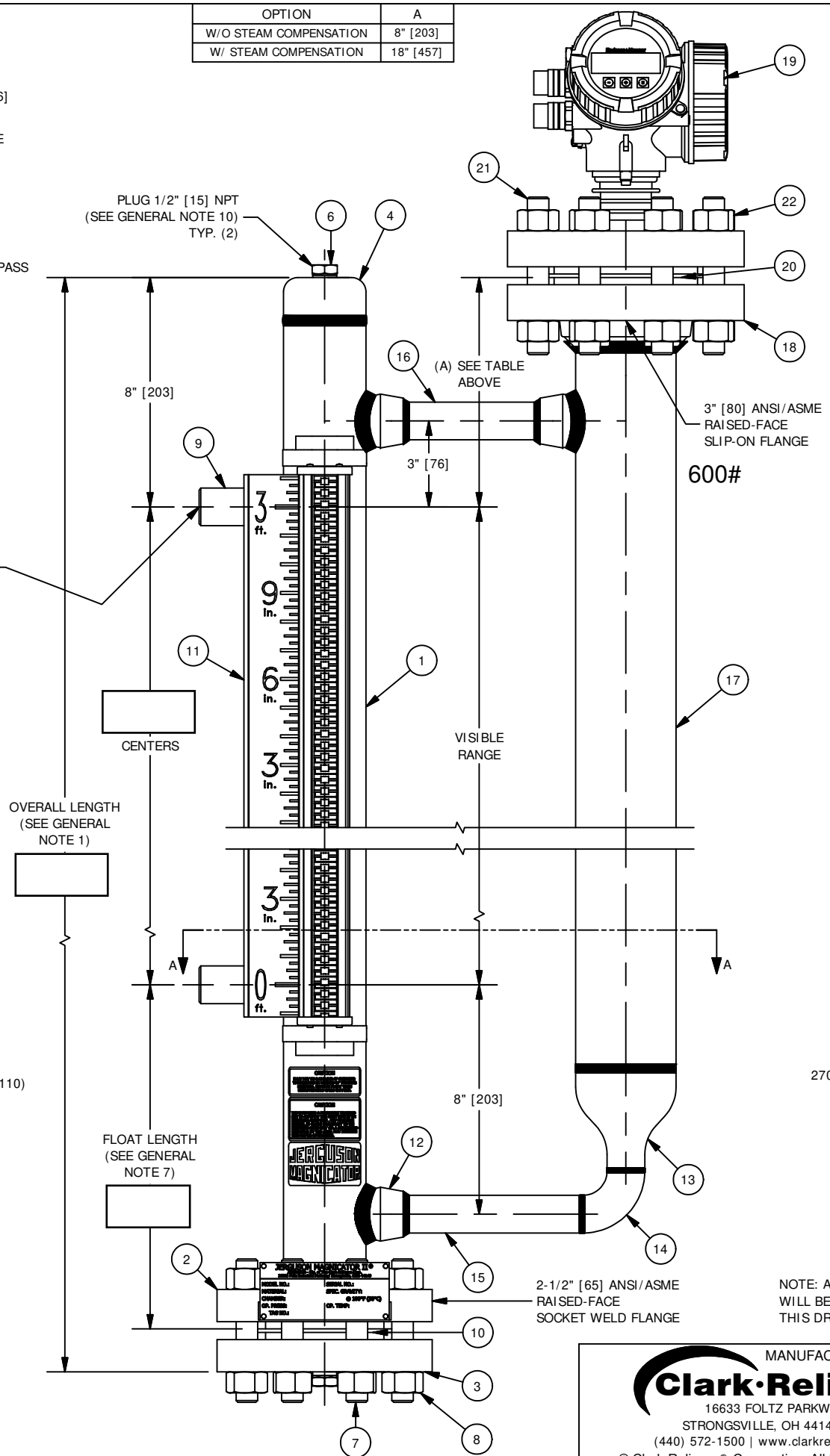

NOTE: AS STANDARD, PROCESS CONNECTIONS WILL BE ORIENTED AT 0°. THEY ARE SHOWN IN THIS DRAWING AT 90° FOR EASE OF VIEWING.

BILL OF MATERIAL			
NO.	NAME OF PART	MATERIAL	REMARKS
1	MAGNicator STANDPIPE		
2	FLANGE, SOCKET WELD		
3	FLANGE, THREADED		
4	CAP		
5	FLOAT		
6	PLUG		
7	STUD		
8	HEAVY HEX NUT		
9	PROCESS CONNECTION		
10	GASKET		
11	INDICATOR		
12	PIPET		
13	REDUCER, CONCENTRIC		
14	ELBOW		
15	STANDPIPE NIPPLE		
16	STANDPIPE NIPPLE		
17	BY-PASS STANDPIPE		
18	FLANGE, SOCKET WELD		
19	GUIDED WAVE RADAR, FLANGED		
20	GASKET		
21	STUD		
22	HEAVY HEX NUT		

OPERATING CONDITIONS	
MAX PRESSURE	
MAX TEMPERATURE	
MIN SPECIFIC GRAVITY	
PROCESS FLUID	

SECTION A-A

MANUFACTURED BY  
**Clark-Reliance®**  
 16633 FOLTZ PARKWAY  
 STRONGSVILLE, OH 44149 USA  
 (440) 572-1500 | www.clarkreliance.com  
 © Clark-Reliance® Corporation. All Rights Reserved.

**JERGUSON®**  
**MODEL MGWR-SW**  
 MAGNicator II COUPLED WITH BY-PASS CHAMBER  
 FOR GUIDED WAVE RADAR TRANSMITTER  
 (W/ 600-2500# ANSI/ASME FLANGES)

DRAWN: SSF	REV.:
CHECKED: MK	1
DATE: 1/22/2014	
REVISION: 1	
DRAWING NO.: MGWR-SW6	