



Level



Pressure



Flow



Temperature



Liquid  
Analysis



Registration



Systems  
Components



Services



Solutions

## Operating Instructions

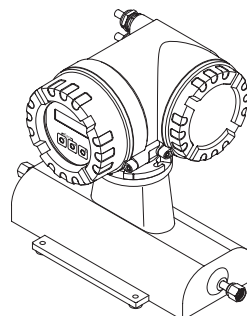
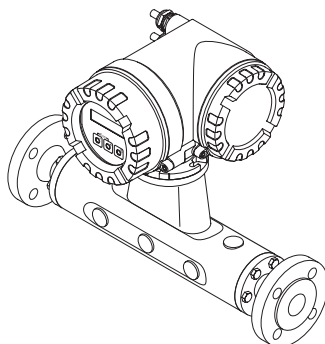
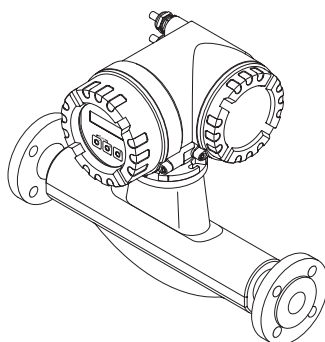

# Proline Promass 84

Coriolis Mass Flow Measuring System  
for Custody Transfer



## Brief operating instructions

These brief operating instructions show you how to configure your measuring device quickly and easily:

<b>Safety instructions</b>	Page 7
▼	
<b>Installation</b>	Page 13
▼	
<b>Wiring</b>	Page 24
▼	
<b>Display and operating elements</b>	Page 31
▼	
<b>Commissioning with “QUICK SETUP”</b>	Page 52
<p>You can commission your measuring device quickly and easily, using the special “Quick Setup” menu. It enables you to configure important basic functions using the local display, for example display language, measured variables, units of measures, type of signal, etc.</p> <p>The following adjustments can be made separately as necessary:</p> <ul style="list-style-type: none"> <li>– Zero point adjustment</li> <li>– Density adjustment</li> </ul>	
▼	
<b>Application-specific commissioning</b>	Page 53
<p>In the “Quick Setup Commissioning” you have the option of launching other, application-specific Quick Setups, for instance the menu for measuring pulsating flow, etc.</p>	
▼	
<b>Customer- specific configuration</b>	Page 34
<p>Complex measuring operations necessitate additional functions that you can configure as necessary with the aid of the function matrix, and customise to suit your process parameters.</p> <p> <b>Note!</b> All functions are described in detail, as is the function matrix itself, in the “<i>Description of Device Functions</i>” manual which is a separate part of these Operating Instructions!</p>	
▼	
<b>Data storage</b>	Page 34 ff.
<p>The configuration of the transmitter can be stored on the integrated T-DAT data storage device.</p> <p> <b>Note!</b> For time-saving commissioning, the settings stored in the T-DAT can be transmitted:</p> <ul style="list-style-type: none"> <li>– For equivalent measuring points (equivalent configuration,)</li> <li>– In the event of device/board replacement.</li> </ul>	



### Note!

Always start trouble-shooting with the checklist on Page 75 if faults occur after commissioning or during operation. The routine takes you directly to the cause of the problem and the appropriate remedial measures.

## QUICK SETUP "Commissioning"



Note!

More detailed information on running Quick Setup menus, especially for devices without a local display, can be found in the "Commissioning" section. see Page 52

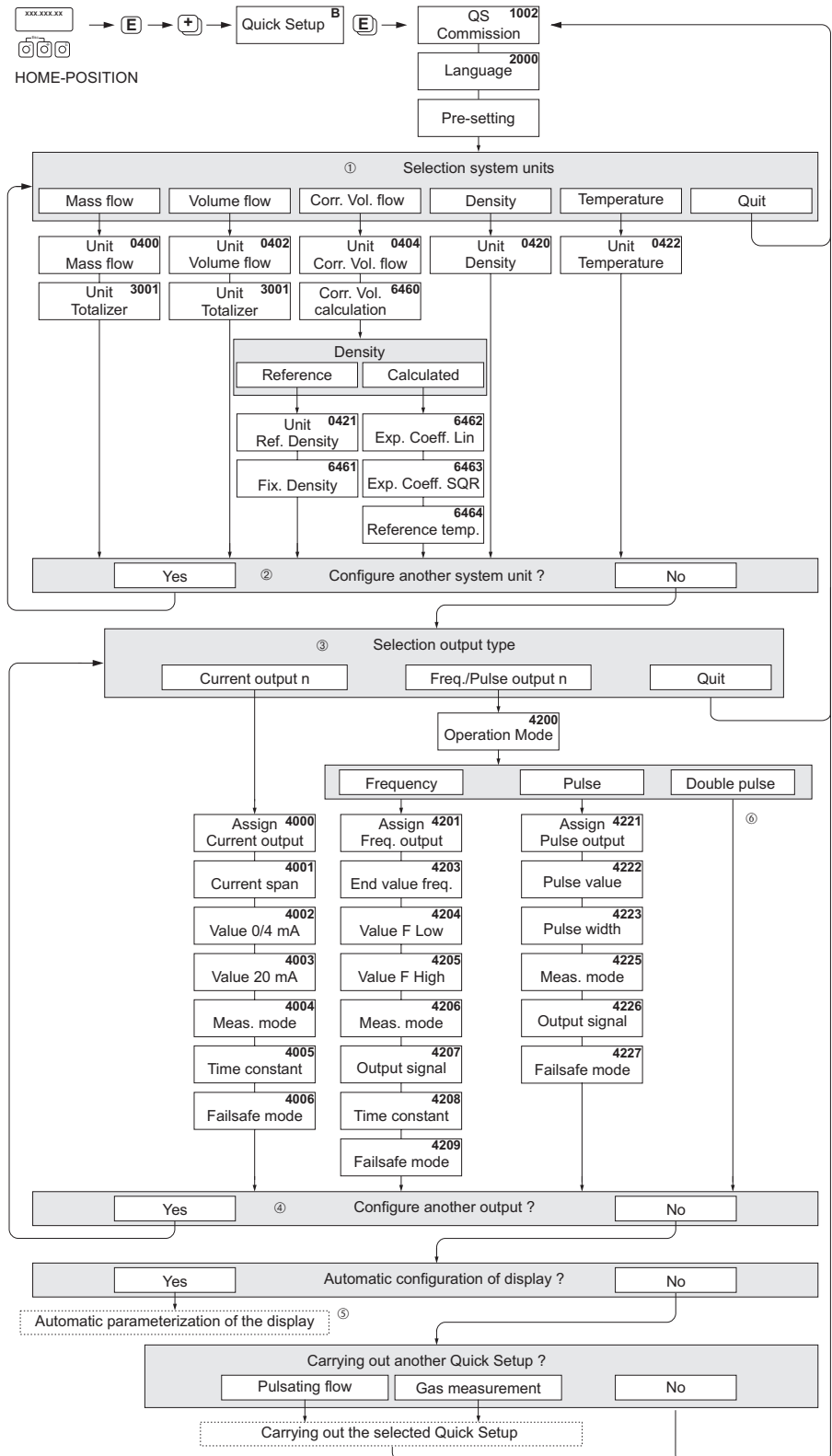

a0001786-en

Fig. 1: "QUICK SETUP COMMISSIONING"- menu for straightforward configuration of the major device functions



## Note!

- The display returns to the cell SETUP COMMISSIONING (1002) if you press the ESC key combination during parameter interrogation. The stored parameters remain valid.
- ① Only units not yet configured in the current Setup are offered for selection in each cycle.  
The unit for mass, volume and corrected volume is derived from the corresponding flow unit.
- ② The “YES” option remains visible until all the units have been configured.  
“NO” is the only option displayed when no further units are available.
- ③ Only the outputs not yet configured in the current Setup are offered for selection in each cycle.
- ④ The “YES” option remains visible until all the outputs have been parameterized.  
“NO” is the only option displayed when no further outputs are available.
- ⑤ The “automatic parameterization of the display” option contains the following basic settings/factory settings:  
YES: Main line = Mass flow; Additional line = Totalizer 1;  
Information line = Operating/system conditions  
NO: The existing (selected) settings remain.
- ⑥ The “DOUBLE PULS C.T.” function can only be selected for frequency/pulse output 2 and only if the "PULSE" operating mode was selected for frequency/pulse output 1.  
The frequency/pulse output 2 then works with the parameters selected by frequency/pulse output 1, but phase-shifted by 90°.

## Table of contents

<b>1</b>	<b>Safety instructions</b>	<b>7</b>	<b>5</b>	<b>Operation</b>	<b>31</b>
1.1	Designated use	7	5.1	Display and operating elements	31
1.2	Installation, commissioning and operation	7	5.1.1	Readings displayed (operation mode)	32
1.3	Operational safety	7	5.1.2	Additional display functions	32
1.4	Return	8	5.1.3	Icons	33
1.5	Notes on safety conventions and icons	8	5.2	Brief operating instructions to the function matrix	34
<b>2</b>	<b>Identification</b>	<b>9</b>	5.2.1	General notes	35
2.1	Device designation	9	5.2.2	Enabling the programming mode	35
2.1.1	Nameplate of the transmitter	9	5.2.3	Disabling the programming mode	35
2.1.2	Nameplate of the sensor	10	5.3	Error messages	36
2.1.3	Additional nameplate for suitability for custody transfer measurement	10	5.3.1	Type of error	36
2.1.4	Nameplate for connections	11	5.3.2	Error message type	36
2.2	Certificates and approvals	11	5.3.3	Confirming error messages	37
2.3	Registered trademarks	12	5.4	Communication	37
<b>3</b>	<b>Installation</b>	<b>13</b>	5.4.1	Operating options	38
3.1	Incoming acceptance, transport and storage	13	5.4.2	Current device description files	39
3.1.1	Incoming acceptance	13	5.4.3	Device and process variables	40
3.1.2	Transport	13	5.4.4	Universal / Common practice HART commands	41
3.1.3	Storage	14	5.4.5	Device status / Error messages	46
3.2	Installation conditions	14	5.4.6	Switching HART write protection on and off	51
3.2.1	Dimensions	14	<b>6</b>	<b>Commissioning</b>	<b>52</b>
3.2.2	Mounting location	14	6.1	Function check	52
3.2.3	Orientation	16	6.2	Switching on the measuring device	52
3.2.4	Heating	18	6.3	Quick Setup	53
3.2.5	Thermal insulation	18	6.3.1	Quick Setup "Commissioning"	53
3.2.6	Inlet and outlet runs	18	6.3.2	Quick Setup "Pulsating Flow"	55
3.2.7	Vibrations	19	6.3.3	Quick Setup "Gas Measurement"	58
3.2.8	Limiting flow	19	6.3.4	Data back-up with "T-DAT SAVE/LOAD"	60
3.3	Installation instructions	20	6.4	Configuration	61
3.3.1	Turning the transmitter housing	20	6.4.1	Current output: active/passive	61
3.3.2	Installing the wall-mount transmitter housing	21	6.4.2	Pulse/frequency outputs 1 and 2	62
3.3.3	Turning the local display	23	6.5	Adjustment	63
3.4	Post-installation check	23	6.5.1	Zero point adjustment	63
<b>4</b>	<b>Wiring</b>	<b>24</b>	6.5.2	Density adjustment	64
4.1	Connecting the remote version	24	6.6	Purge and pressure monitoring connections	66
4.1.1	Connecting connecting cable for sensor/transmitter	24	6.7	Memory (HistoROM)	66
4.1.2	Cable specification, connecting cable	25	6.7.1	HistoROM/S-DAT (sensor-DAT)	66
4.2	Connecting the measuring unit	25	6.7.2	HistoROM/T-DAT (transmitter-DAT)	66
4.2.1	Transmitter connection	25	<b>7</b>	<b>Custody transfer measurement</b>	<b>67</b>
4.2.2	Terminal assignment	27	7.1	Suitability for custody transfer measurement, approval by the Standards Authorities, repeated calibration due to legal metrology controls	67
4.2.3	HART connection	28	7.1.1	Approval for custody transfer	67
4.3	Degree of protection	29	7.1.2	Special features of working in the custody transfer mode	67
4.4	Post-connection check	30	7.2	Definition of terms	68
			7.3	Verification process	69
			7.3.1	Setting up custody transfer mode	69
			7.3.2	Disabling custody transfer mode	71

<b>8</b>	<b>Maintenance</b> .....	<b>72</b>
8.1	External cleaning .....	72
8.2	Replacing seals .....	72
<b>9</b>	<b>Accessories</b> .....	<b>73</b>
9.1	Device-specific accessories .....	73
9.2	Measuring principle-specific accessories .....	73
9.3	Communication-specific accessories .....	73
9.4	Service-specific accessories .....	74
<b>10</b>	<b>Trouble-shooting</b> .....	<b>75</b>
10.1	Trouble-shooting instructions .....	75
10.2	System error messages .....	76
10.3	Process error messages .....	80
10.4	Process errors without messages .....	81
10.5	Response of outputs to errors .....	82
10.6	Spare parts .....	83
	10.6.1 Removing and installing printed circuit boards .....	84
	10.6.2 Replacing the device fuse .....	88
10.7	Return .....	89
10.8	Disposal .....	89
10.9	Software history .....	89
<b>11</b>	<b>Technical data</b> .....	<b>90</b>
11.1	Technical data at a glance .....	90
	11.1.1 Applications .....	90
	11.1.2 Function and system design .....	90
	11.1.3 Input .....	90
	11.1.4 Output .....	93
	11.1.5 Power supply .....	94
	11.1.6 Performance characteristics .....	95
	11.1.7 Operating conditions: Installation .....	99
	11.1.8 Operating conditions: Environment .....	99
	11.1.9 Operating conditions: Process .....	99
	11.1.10 Mechanical construction .....	105
	11.1.11 Human interface .....	108
	11.1.12 Certificates and approvals .....	108
	11.1.13 Ordering information .....	109
	11.1.14 Accessories .....	109
	11.1.15 Documentation .....	110
	<b>Index</b> .....	<b>111</b>

# 1 Safety instructions

## 1.1 Designated use

The measuring device described in these Operating Instructions is to be used only for measuring the mass flow rate of liquids and gases. At the same time, the system also measures fluid density and fluid temperature. These parameters are then used to calculate other variables such as volume flow. Fluids with widely differing properties can be measured.

Examples:

- Chocolate, condensed milk, liquid sugar
- Oils, fats
- Acids, alkalis, lacquers, paints, solvents and cleaning agents
- Pharmaceuticals, catalysts, inhibitors
- Suspensions
- Gases, liquefied gases, etc.

Resulting from incorrect use or from use other than that designated the operational safety of the measuring devices can be suspended. The manufacturer accepts no liability for damages being produced from this.

## 1.2 Installation, commissioning and operation

Note the following points:

- Installation, connection to the electricity supply, commissioning and maintenance of the device must be carried out by trained, qualified specialists authorised to perform such work by the facility's owner-operator.  
The specialist must have read and understood these Operating Instructions and must follow the instructions they contain.
- The device must be operated by persons authorised and trained by the facility's owner-operator. Strict compliance with the instructions in the Operating Instruction is mandatory.
- Endress+Hauser will be happy to assist in clarifying the chemical resistance properties of parts wetted by special fluids, including fluids used for cleaning. However the user is responsible for the choice of fluid wetted materials as regards to their in-process resistance to corrosion. The manufacturer refuses to accept liability.
- If carrying out welding work on the piping, the welding unit may not be grounded by means of the measuring device.
- The installer must ensure that the measuring system is correctly wired in accordance with the wiring diagrams. The transmitter must be earthed unless special protection measures have been taken e.g. galvanically isolated power supply SELV or PELV! (SELV = Safe Extra Low Voltage; PELV = Protective Extra Low Voltage)
- Invariably, local regulations governing the opening and repair of electrical devices apply.

## 1.3 Operational safety

Note the following points:

- Measuring systems for use in hazardous environments are accompanied by separate "Ex documentation", which is an integral part of these Operating Instructions. Strict compliance with the installation instructions and ratings as stated in this supplementary documentation is mandatory.  
The symbol on the front of this supplementary Ex documentation indicates the approval and the certification body (Ex Europe, Ex USA, Ex Canada).
- The measuring device complies with the general safety requirements in accordance with EN 61010, the EMC requirements of EN 61326/A1, and NAMUR recommendation NE 21, NE 43 and NE 53.
- For measuring systems used in SIL 2 applications, the separate manual on functional safety must be observed.

- The manufacturer reserves the right to modify technical data without prior notice. Your Endress+Hauser distributor will supply you with current information and updates to these Operating Instructions.
- The separate document on the Pressure Equipment Directive must be observed for devices used in Category II, III or IV installations in accordance with the Pressure Equipment Directive.

## 1.4 Return

The following procedures must be carried out before a flowmeter requiring repair or calibration, for example, is returned to Endress+Hauser:

- Always enclose a duly completed “Declaration of contamination” form. Only then can Endress+Hauser transport, examine and repair a returned device.
- Enclose special handling instructions if necessary, for example a safety data sheet as per EN 91/155/EEC.
- Remove all residues. Pay special attention to the grooves for seals and crevices which could contain residues. This is particularly important if the substance is hazardous to health, e.g. flammable, toxic, caustic, carcinogenic, etc.  
With Promass A and Promass M the threaded process connections must first be removed from the sensor and then cleaned.



Note!

You will find a preprinted “Declaration of contamination” form at the back of this manual.



Warning!

- Do not return a measuring device if you are not absolutely certain that all traces of hazardous substances have been removed, e.g. substances which have penetrated crevices or diffused through plastic.
- Costs incurred for waste disposal and injury (burns, etc.) due to inadequate cleaning will be charged to the owner-operator.

## 1.5 Notes on safety conventions and icons

The devices are designed to meet state-of-the-art safety requirements, have been tested, and left the factory in a condition in which they are safe to operate. The devices comply with the applicable standards and regulations in accordance with EN 61010 “Protection Measures for Electrical Equipment for Measurement, Control, Regulation and Laboratory Procedures”. They can, however, be a source of danger if used incorrectly or for other than the designated use.

Consequently, always pay particular attention to the safety instructions indicated in these Operating Instructions by the following icons:



Warning!

“Warning” indicates an action or procedure which, if not performed correctly, can result in injury or a safety hazard. Comply strictly with the instructions and proceed with care.



Caution!

“Caution” indicates an action or procedure which, if not performed correctly, can result in incorrect operation or destruction of the device. Comply strictly with the instructions.



Note!

“Note” indicates an action or procedure which, if not performed correctly, can have an indirect effect on operation or trigger an unexpected response on the part of the device.



## 2 Identification

### 2.1 Device designation

The “Promass 84” flow measuring system consists of the following components:

- Promass 84 transmitter
- Promass F, Promass M, Promass A sensors

Two versions are available:

- Compact version: transmitter and sensor form a single mechanical unit.
- Remote version: transmitter and sensor are installed separately

#### 2.1.1 Nameplate of the transmitter

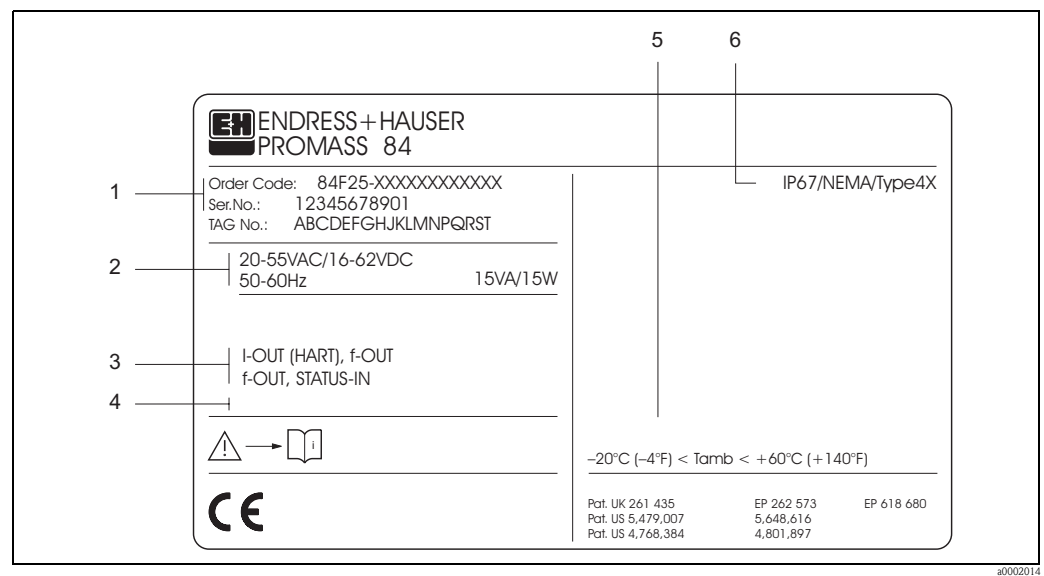

Fig. 2: Nameplate specifications for the “Promass 84” transmitter (example)

- 1 Order code / serial number: See the specifications on the order confirmation for the meanings of the individual letters and digits
- 2 Power supply / frequency: 20...55 V AC / 16...62 V DC / 50...60 Hz  
Power consumption: 15 VA / 15 W
- 3 Available inputs / outputs:  
I-OUT (HART): with current output (HART)  
f-OUT (1): with pulse/frequency output  
f-OUT (2): with pulse/frequency output  
STATUS-IN: with status input (auxiliary input)
- 4 Reserved for information on special products
- 5 Ambient temperature range
- 6 Degree of protection

### 2.1.2 Nameplate of the sensor

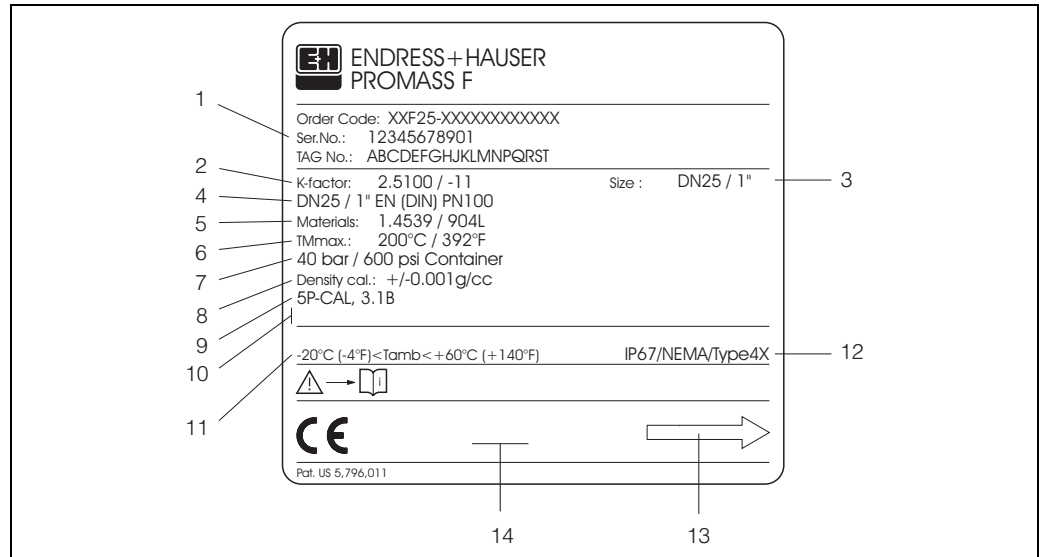

Fig. 3: Nameplate specifications for the "Promass F" sensor (example)

- 1 Order code / serial number: See the specifications on the order confirmation for the meanings of the individual letters and digits
- 2 Calibration factor: 2.5100; zero point: -11
- 3 Nominal diameter device: DN 25 / 1"
- 4 Flange nominal diameter: DN 25 / 1"  
Nominal pressure: EN (DIN) PN 100 bar
- 5 Material of measuring tubes: Stainless steel 1.4539/904L
- 6 TMmax +200 °C / +392 °F (max. fluid temperature)
- 7 Pressure range of secondary containment: max. 40 bar (600 psi)
- 8 Accuracy of density measurement: ± 0.001 g/cc
- 9 Additional information (examples):
  - With 5-point calibration
  - With 3.1 B certificate for wetted materials
- 10 Reserved for information on special products
- 11 Ambient temperature range
- 12 Degree of protection
- 13 Flow direction
- 14 Reserved for additional information on device version (approvals, certificates)

### 2.1.3 Additional nameplate for suitability for custody transfer measurement

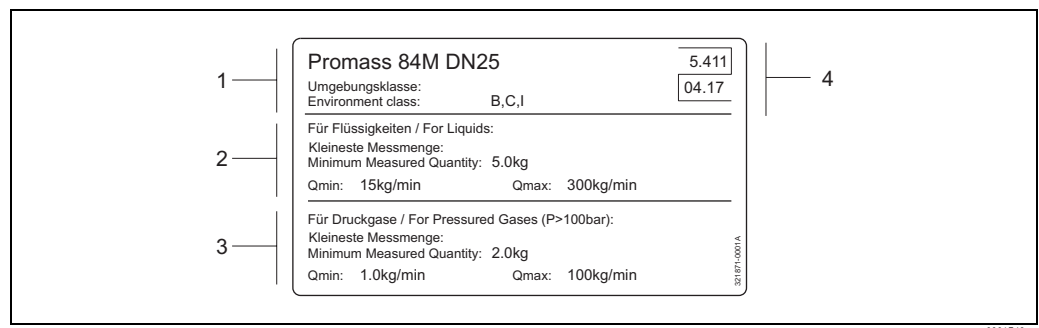

Fig. 4: Nameplate specifications for the suitability of "Promass 84" for custody transfer measurement (example)

- 1 Ambient classes
- 2 Smallest measured quantity for liquids
- 3 Smallest measured quantity for gases
- 4 Symbol for custody transfer consisting of the number and issue date

### 2.1.4 Nameplate for connections

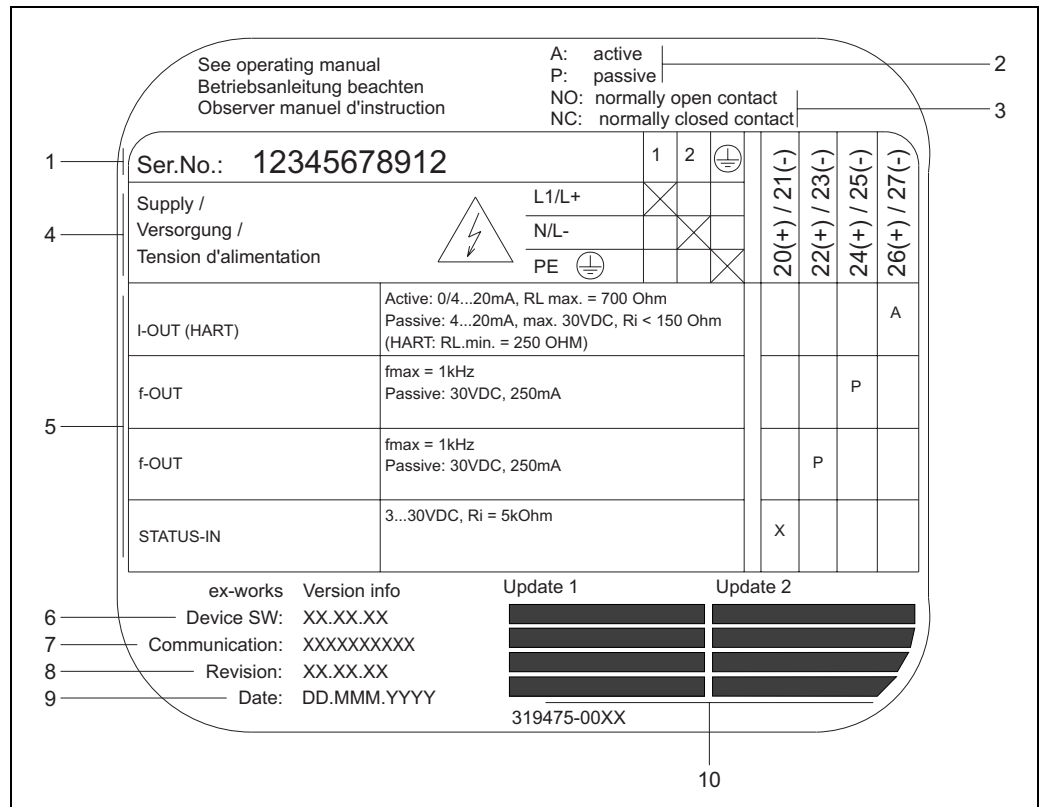

Fig. 5: Nameplate specifications for transmitter connections (example)

- 1 Serial number
- 2 Possible configuration of current output
- 3 Possible configuration of relay contacts
- 4 Terminal assignment, cable for power supply: 85...260 V AC, 20...55 V AC, 16...62 V DC  
Terminal No. 1: L1 for AC, L+ for DC  
Terminal No. 2: N for AC, L- for DC
- 5 Signals present at inputs and outputs, possible configuration and terminal assignment (20...27), see also "Electrical values of inputs/outputs" → Page 93
- 6 Version of device software currently installed
- 7 Installed communication type, e.g.: HART, PROFIBUS PA, etc.
- 8 Information on current communication software (Device Revision and Device Description), e.g.: Dev. 01 / DD 01 for HART
- 9 Date of installation
- 10 Current updates to data specified in points 6 to 9

### 2.2 Certificates and approvals

The devices are designed in accordance with good engineering practice to meet state-of-the-art safety requirements, have been tested, and left the factory in a condition in which they are safe to operate. The devices comply with the applicable standards and regulations in accordance with EN 61010 "Protection Measures for Electrical Equipment for Measurement, Control, Regulation and Laboratory Procedures" and with the EMC requirements of EN 61326/A1. The measuring system described in these Operating Instructions thus complies with the statutory requirements of the EC Directives. Endress+Hauser confirms successful testing of the device by affixing to it the CE mark.

## 2.3 Registered trademarks

KALREZ® and VITON®

Registered trademarks of E.I. Du Pont de Nemours & Co., Wilmington, USA

TRI-CLAMP®

Registered trademark of Ladish & Co., Inc., Kenosha, USA

SWAGELOK®

Registered trademark of Swagelok & Co., Solon, USA

HART®

Registered trademark of HART Communication Foundation, Austin, USA

HistoROM™, S-DAT®, T-DAT™, F-CHIP®, ToF Tool - Fieldtool® Package, Fieldcheck®,  
Applicator®

Registered or registration-pending trademarks of Endress+Hauser Flowtec AG, Reinach, CH

## 3 Installation

### 3.1 Incoming acceptance, transport and storage

#### 3.1.1 Incoming acceptance

On receipt of the goods, check the following points:

- Check the packaging and the contents for damage.
- Check the shipment, make sure nothing is missing and that the scope of supply matches your order.

#### 3.1.2 Transport

The following instructions apply to unpacking and to transporting the device to its final location:

- Transport the devices in the containers in which they are delivered.
- The covers or caps fitted to the process connections prevent mechanical damage to the sealing faces and the ingress of foreign matter to the measuring tube during transportation and storage. Consequently, do not remove these covers or caps until immediately before installation.
- Do not lift measuring devices of nominal diameters DN 40...250 by the transmitter housing or the connection housing in the case of the remote version (Fig. 6). - Use webbing slings slung round the two process connections. Do not use chains, as they could damage the housing.
- In the case of the Promass M / DN 80 sensor, use only the lifting eyes on the flanges to lift the assembly!



Warning!

Risk of injury if the measuring device slips. The center of gravity of the assembled measuring device might be higher than the points around which the slings are slung.

At all times, therefore, make sure that the device does not unexpectedly turn around its axis or slip.

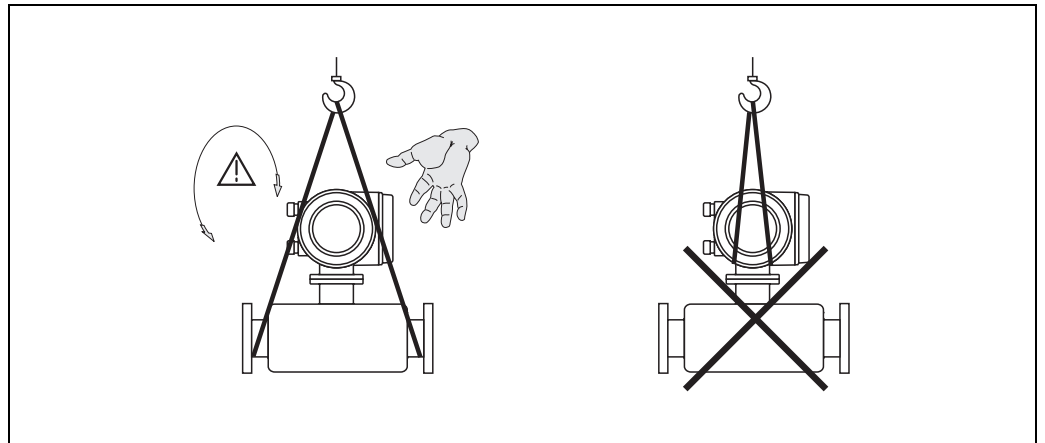

Fig. 6: Instructions for transporting sensors with DN 40...250

F06-xxxxxxx-22-00-00-xx-000

### 3.1.3 Storage

Note the following points:

- Pack the measuring device in such a way as to protect it reliably against impact for storage (and transportation). The original packaging provides optimum protection.
- The permissible storage temperature is  $-40\dots+80\text{ °C}$  (preferably  $+20\text{ °C}$ ).
- Do not remove the protective covers or caps on the process connections until you are ready to install the device.
- The measuring device must be protected against direct sunlight during storage in order to avoid unacceptably high surface temperatures.

## 3.2 Installation conditions

Note the following points:

- No special measures such as supports are necessary. External forces are absorbed by the construction of the instrument, for example the secondary containment.
- The high oscillation frequency of the measuring tubes ensures that the correct operation of the measuring system is not influenced by pipe vibrations.
- No special precautions need to be taken for fittings which create turbulence (valves, elbows, T-pieces, etc.), as long as no cavitation occurs.
- For mechanical reasons and in order to protect the pipe, it is advisable to support heavy sensors.

### 3.2.1 Dimensions

All the dimensions and lengths of the sensor and transmitter are provided in the separate documentation "Technical Information".

### 3.2.2 Mounting location

Entrained gas bubbles in the measuring tube can result in an increase in measuring errors.

**Avoid** the following locations:

- Highest point of a pipeline. Risk of air accumulating.
- Directly upstream of a free pipe outlet in a vertical pipeline.

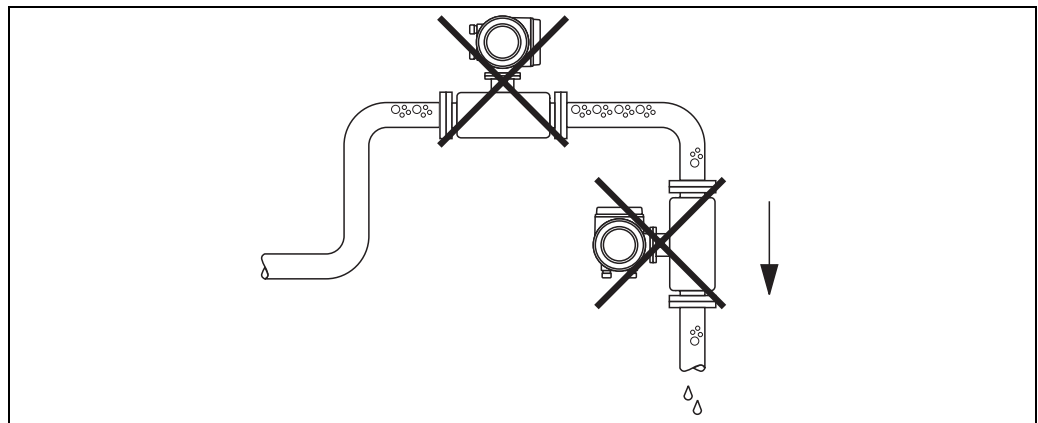

F06-xxxxxxx-11-00-00-xx-004

Fig. 7: Mounting location

The proposed configuration in the following diagram, however, permits installation in a vertical pipeline. Pipe restrictors or the use of an orifice plate with a smaller cross-section than the nominal diameter prevent the sensor from running empty during measurement.

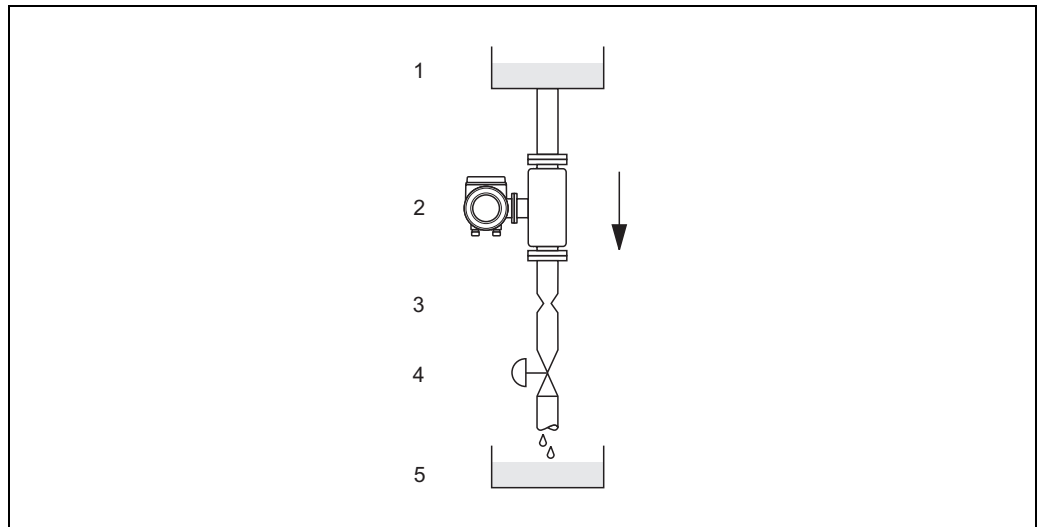

Fig. 8: Installation in a vertical pipe (e.g. for batching applications)

- 1 Supply tank
- 2 Sensor
- 3 Orifice plate, pipe restrictions (see Table)
- 4 Valve
- 5 Batching tank

Promass F, M / DN	8	15	25	40	50	80	100 <sup>1)</sup>	150 <sup>1)</sup>	250 <sup>1)</sup>
Ø Orifice plate, pipe restriction	6 mm	10 mm	14 mm	22 mm	28 mm	50 mm	65 mm	90 mm	150 mm
1) Promass F, M only									

Promass A / DN	2	4
Ø Orifice plate, pipe restriction	1.5 mm	3.0 mm

**System pressure**

It is important to ensure that cavitation does not occur, because it would influence the oscillation of the measuring tube. No special measures need to be taken for fluids which have properties similar to water under normal conditions.

In the case of liquids with a low boiling point (hydrocarbons, solvents, liquefied gases) or in suction lines, it is important to ensure that pressure does not drop below the vapour pressure and that the liquid does not start to boil. It is also important to ensure that the gases that occur naturally in many liquids do not outgas. Such effects can be prevented when system pressure is sufficiently high.

Consequently, it is generally best to install the sensor:

- downstream from pumps (no danger of vacuum),
- at the lowest point in a vertical pipe.

### 3.2.3 Orientation

Make sure that the direction of the arrow on the nameplate of the sensor matches the direction of flow (direction in which the fluid flows through the pipe).

#### Orientation Promass A

##### *Vertical:*

Recommended orientation with upward direction of flow. When fluid is not flowing, entrained solids will sink down and gases will rise away from the measuring tube. The measuring tubes can be completely drained and protected against solids build-up.

##### *Horizontal:*

When installation is correct the transmitter housing is above or below the pipe. This arrangement means that no gas or solid deposits can accumulate in the curved measuring tube (single-tube system).

Do not install the sensor in such a way that it is suspended in the pipe, in other words without support or attachment. This is to avoid excessive strain at the process connection. The base plate of the sensor housing is designed for mounting on a tabletop, wall or post.

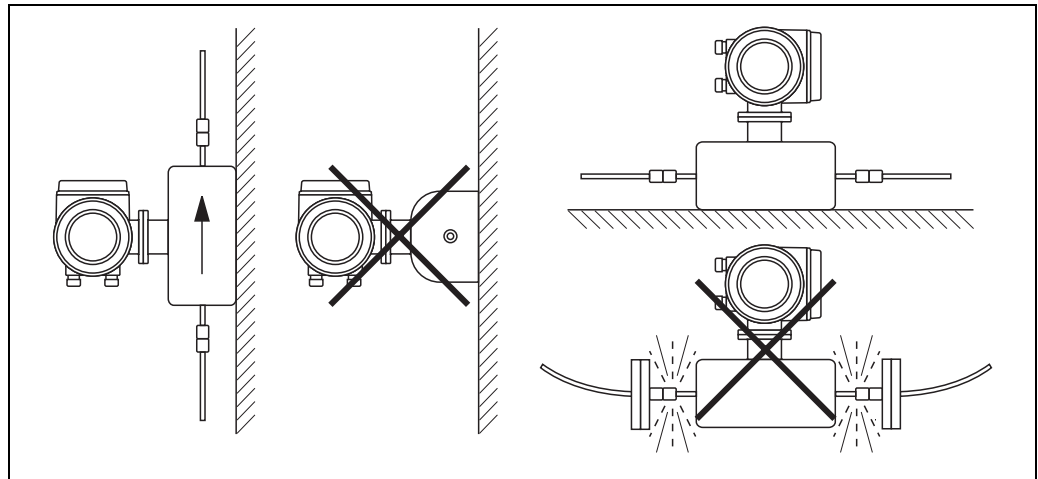

F06-xxxxxxx-11-00-00-xx-005

Fig. 9: Vertical and horizontal orientation (Promass A)



### Orientation Promass F, M

Make sure that the direction of the arrow on the nameplate of the sensor matches the direction of flow (direction in which the fluid flows through the pipe).

#### Vertical:

Recommended orientation with upward direction of flow (View V). When fluid is not flowing, entrained solids will sink down and gases will rise away from the measuring tube. The measuring tubes can be completely drained and protected against solids build-up.

#### Horizontal (Promass F, M):

The measuring tubes of Promass F and M must be horizontal and beside each other. When installation is correct the transmitter housing is above or below the pipe (View H1/H2). Always avoid having the transmitter housing in the same horizontal plane as the pipe.

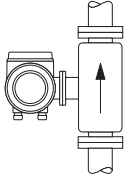
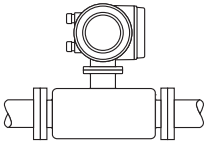
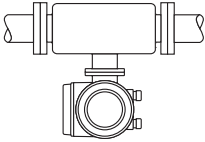
	Promass F, M Standard, compact	Promass F, M Standard, remote
<p><b>Fig. V: Vertical orientation</b></p>  <p>F06-xxxxxxxx-11-00-00-xx-008</p>	✓✓	✓✓
<p><b>Fig. H1: Horizontal orientation</b> Transmitter head up</p>  <p>F06-xxxxxxxx-11-00-00-xx-009</p>	✓✓	✓✓
<p><b>Fig. H2: Horizontal orientation</b> Transmitter head down</p>  <p>F06-xxxxxxxx-11-00-00-xx-010</p>	✓✓ ①	✓✓ ①
<p>✓✓ = Recommended orientation                      ✓ = Orientation recommended in certain situations                      ✗ = Impermissible orientation</p>		

In order to ensure that the maximum permissible ambient temperature for the transmitter (−20...+60 °C, optional −40...+60 °C) is not exceeded, we recommend the following orientations:

① = For fluids with low temperatures, we recommend the horizontal orientation with the transmitter head pointing upwards (Fig. H1) or the vertical orientation (Fig. V).

### Special installation instructions for Promass F



#### Caution!

The two measuring tubes for Promass F are slightly curved. The position of the sensor, therefore, has to be matched to the fluid properties when the sensor is installed horizontally.

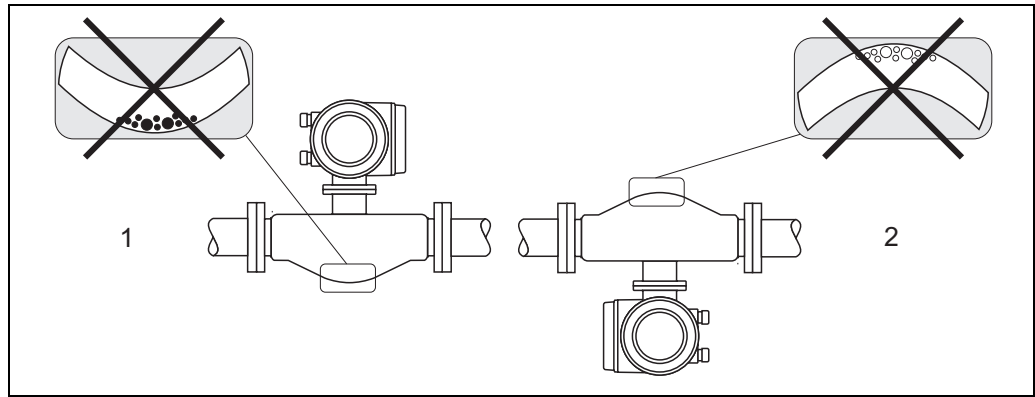

Fig. 10: Promass F, installed horizontally

- 1 Not suitable for fluids with entrained solids. Risk of solids accumulating.  
 2 Not suitable for outgassing fluids. Risk of air accumulating.

### 3.2.4 Heating

Some fluids require suitable measures to avoid loss of heat at the sensor. Heating can be electric, e.g. with heated elements, or by means of hot water or steam pipes made of copper.



#### Caution!

- Risk of electronics overheating! Consequently, make sure that the adapter between sensor and transmitter and the connection housing of the remote version always remain free of insulating material. Note that a certain orientation might be required, depending on the fluid temperature. → Page 16, → Page 17
- When using electrical heat tracing whose heat is regulated using phase control or by pulse packs, it cannot be ruled out that the measured values are influenced by magnetic fields which may occur, (i.e. at values greater than those permitted by the EC standard (Sinus 30 A/m)). In such cases, the sensor must be magnetically screened (except for Promass M).  
 The secondary containment can be shielded with tin plates or electric sheets without privileged direction (e.g. V330-35A) with the following properties:
  - Relative magnetic permeability  $\mu_r \geq 300$
  - Plate thickness  $d \cdot 0.35 \text{ mm}$
- Information on permissible temperature ranges → Page 99

Special heating jackets which can be ordered as accessories from Endress+Hauser are available for the sensors.

### 3.2.5 Thermal insulation

Some fluids require suitable measures to avoid loss of heat at the sensor. A wide range of materials can be used to provide the required thermal insulation.

### 3.2.6 Inlet and outlet runs

There are no installation requirements regarding inlet and outlet runs. If possible, install the sensor well clear of fittings such as valves, T-pieces, elbows, etc.

### **3.2.7 Vibrations**

The high oscillation frequency of the measuring tubes ensures that the correct operation of the measuring system is not influenced by pipe vibrations. Consequently, the sensors require no special measures for attachment.

### **3.2.8 Limiting flow**

Relevant information can be found in the “Technical Data” section under Measuring range  
→ Seite 91 or Limiting flow → Page 100.

### 3.3 Installation instructions

#### 3.3.1 Turning the transmitter housing

##### Turning the aluminium field housing



Warning!

The rotating mechanism for devices for hazardous area Zone 1 (ATEX) or Class I Div. 1 (FM/CSA) is different to that described here. The procedure for turning these housings is described in the Ex-specific documentation.

1. Loosen the two securing screws.
2. Turn the bayonet catch as far as it will go.
3. Carefully lift the transmitter housing as far as it will go.
4. Turn the transmitter housing to the desired position (max. 2 x 90° in either direction).
5. Lower the housing into position and re-engage the bayonet catch.
6. Retighten the two securing screws.

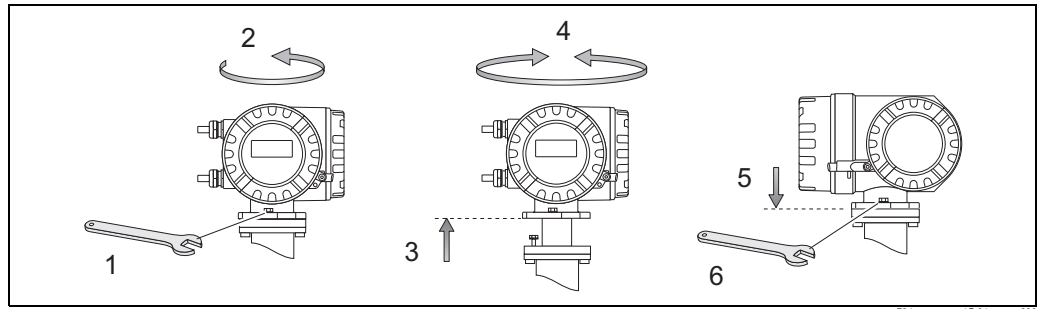

F06-xxxxxxx-17-06-xx-xx-000

Fig. 11: Turning the transmitter housing (aluminium field housing)

##### Turning the stainless steel field housing

1. Loosen the two securing screws.
2. Carefully lift the transmitter housing as far as it will go.
3. Turn the transmitter housing to the desired position (max. 2 x 90° in either direction).
4. Lower the housing into position.
5. Retighten the two securing screws.

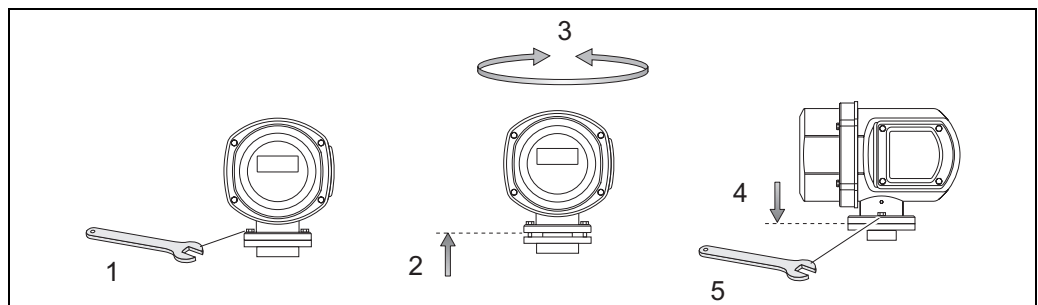

F06-xxxxxxx-17-06-xx-xx-001

Fig. 12: Turning the transmitter housing (stainless steel field housing)

### 3.3.2 Installing the wall-mount transmitter housing

There are various ways of installing the wall-mount transmitter housing:

- Mounted directly on the wall
- Installation in control panel (separate mounting set, accessories) → Page 22
- Pipe mounting (separate mounting set, accessories) → Page 22



Caution!

- Make sure that ambient temperature does not go beyond the permissible range (– 20...+60 °C, optional – 40...+60 °C). Install the device in a shady location. Avoid direct sunlight.
- Always install the wall-mount housing in such a way that the cable entries are pointing down.

#### Mounted directly on the wall

1. Drill the holes as illustrated in the diagram.
2. Remove the cover of the connection compartment (a).
3. Push the two securing screws (b) through the appropriate bores (c) in the housing.
  - Securing screws (M6): max. Ø 6.5 mm
  - Screw head: max. Ø 10.5 mm
4. Secure the transmitter housing to the wall as indicated.
5. Screw the cover of the connection compartment (a) firmly onto the housing.

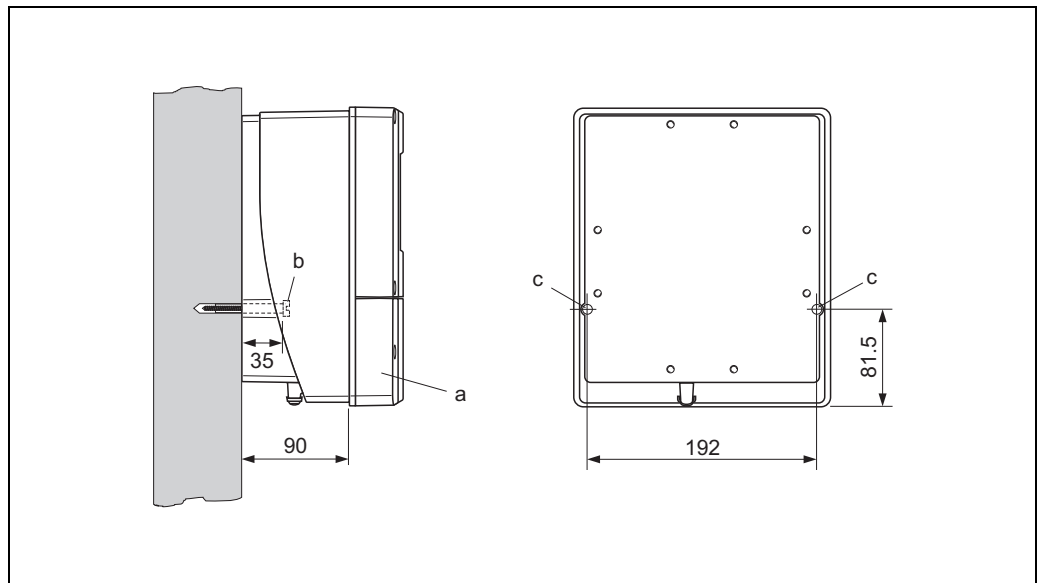

Fig. 13: Mounted directly on the wall

a0001130

### Installation in control panel

1. Prepare the opening in the panel as illustrated in the diagram.
2. Slide the housing into the opening in the panel from the front.
3. Screw the fasteners onto the wall-mount housing.
4. Screw threaded rods into holders and tighten until the housing is solidly seated on the panel wall. Afterwards, tighten the locking nuts. Additional support is not necessary.

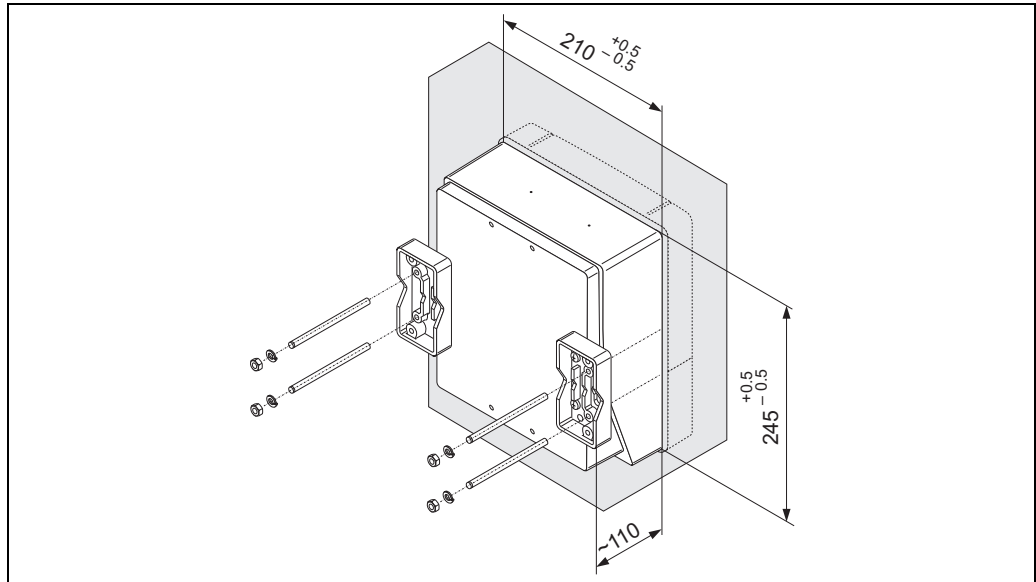

Fig. 14: Panel installation (wall-mount housing)

### Pipe mounting

The assembly should be performed by following the instructions in the diagram.



Caution!

If a warm pipe is used for installation, make sure that the housing temperature does not exceed the max. permitted value of +60 °C.

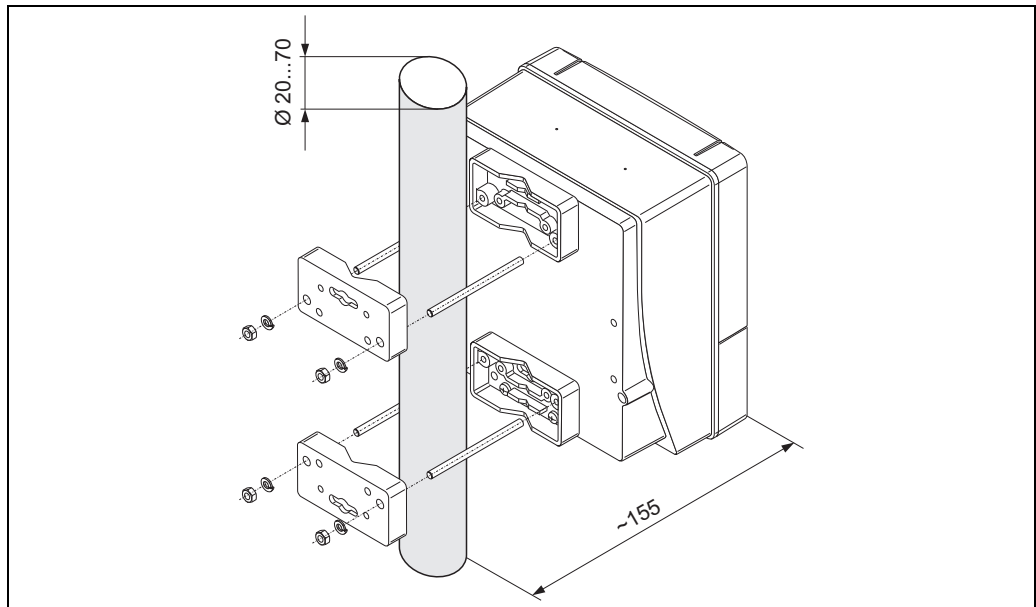

Fig. 15: Pipe mounting (wall-mount housing)

### 3.3.3 Turning the local display

1. Unscrew cover of the electronics compartment from the transmitter housing.
2. Press the side latches on the display module and remove the module from the electronics compartment cover plate.
3. Rotate the display to the desired position (max. 4 x 45 ° in both directions), and reset it onto the electronics compartment cover plate.
4. Screw the cover of the electronics compartment firmly back onto the transmitter housing.

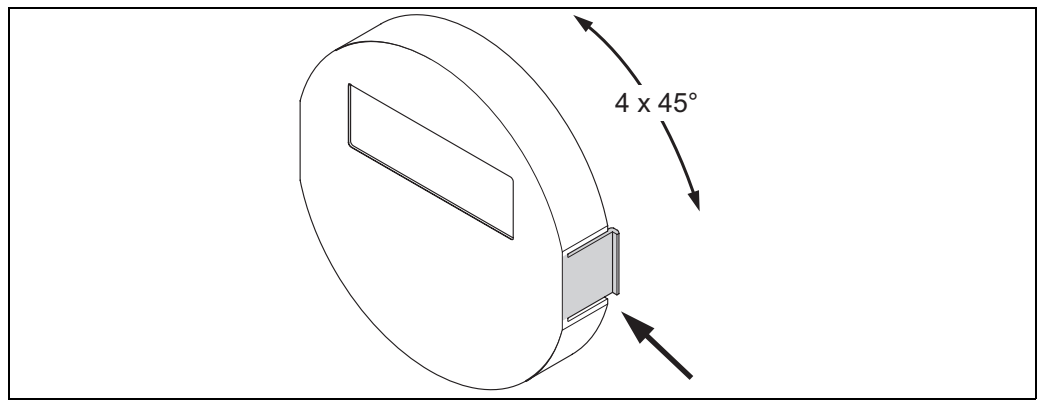

Fig. 16: Turning the local display (field housing)

### 3.4 Post-installation check

Perform the following checks after installing the measuring device in the pipe:

Device condition and specifications	Notes
Is the device damaged (visual inspection)?	-
Does the device correspond to specifications at the measuring point, including process temperature and pressure, ambient temperature, measuring range, etc.?	→ Page 7 ff.
Installation	Notes
Does the arrow on the sensor nameplate match the direction of flow through the pipe?	-
Are the measuring point number and labelling correct (visual inspection)?	-
Is the orientation chosen for the sensor correct, in other words suitable for sensor type, fluid properties (outgassing, with entrained solids) and fluid temperature?	→ Page 14 ff.
Process environment / process conditions	Notes
Is the measuring device protected against moisture and direct sunlight?	-

## 4 Wiring



### Warning!

When connecting Ex-certified devices, see the notes and diagrams in the Ex-specific supplement to these Operating Instructions. Please do not hesitate to contact your Endress+Hauser sales office if you have any questions.

### 4.1 Connecting the remote version

#### 4.1.1 Connecting connecting cable for sensor/transmitter



### Warning!

■ Risk of electric shock. Switch off the power supply before opening the device.

Do not install or wire the device while it is connected to the power supply.

Failure to comply with this precaution can result in irreparable damage to the electronics.

■ Risk of electric shock. Connect the protective earth to the ground terminal on the housing before the power supply is applied.

■ You may only connect the sensor to the transmitter with the same serial number. Communication errors can occur if this is not observed when connecting the devices.

1. Remove the connection compartment cover (a) by loosening the fixing screws on the transmitter and sensor housing.
2. Feed the connecting cable (b) through the appropriate cable runs.
3. Establish the connections between sensor and transmitter in accordance with the wiring diagram:
  - See Fig. 17
  - See wiring diagram in screw cap
4. Screw the connection compartment cover (a) back onto the sensor and transmitter housing.

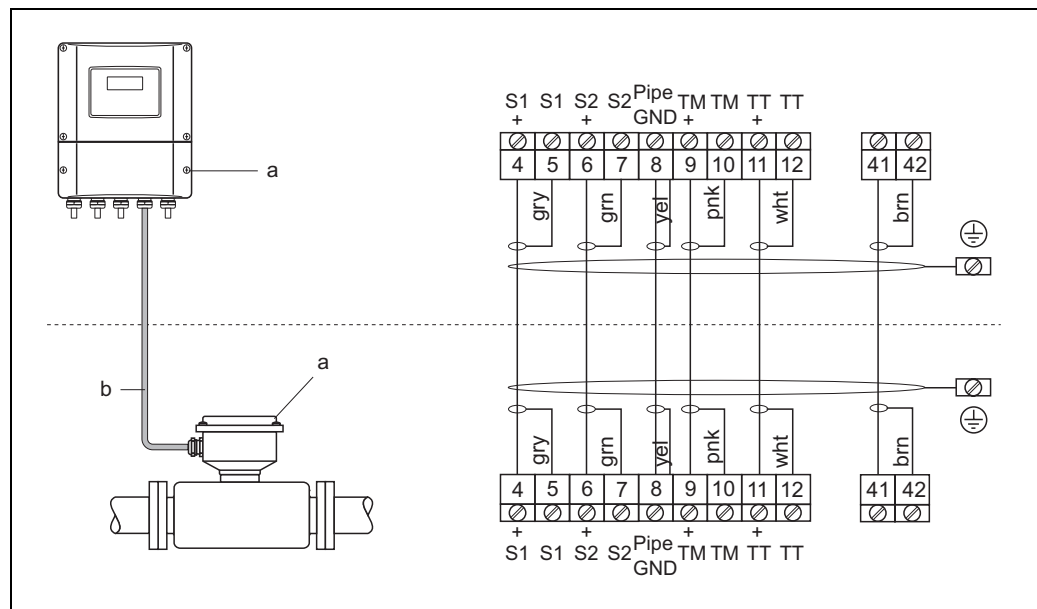

F06-8xxxxxxx-04-xx-xx-en-000

Fig. 17: Connecting the remote version

a Covers of the connection compartments (transmitter, sensor)

b Connecting cable (signal cable)



### 4.1.2 Cable specification, connecting cable

The specifications of the cable connecting the transmitter and the sensor of the remote version are as follows:

- 6 x 0.38 mm<sup>2</sup> PVC cable with common shield and individually shielded cores
- Conductor resistance:  $\leq 50 \Omega/\text{km}$
- Capacitance core/shield:  $\leq 420 \text{ pF/m}$
- Cable length: max. 20 m
- Permanent operating temperature: max. +105 °C



Note!

The cable must be installed securely, to prevent movement.

## 4.2 Connecting the measuring unit

### 4.2.1 Transmitter connection



Warning!

- Risk of electric shock. Switch off the power supply before opening the device. Do not install or wire the device while it is connected to the power supply. Failure to comply with this precaution can result in irreparable damage to the electronics.
  - Risk of electric shock. Connect the protective earth to the ground terminal on the housing before the power supply is applied unless special protection measures have been taken (e.g. galvanically isolated power supply SELV or PELV).
  - Compare the specifications on the nameplate with the local supply voltage and frequency. The national regulations governing the installation of electrical equipment also apply.
1. Unscrew the connection compartment cover (f) from the transmitter housing.
  2. Feed the power supply cable (a) and the signal cable (b) through the appropriate cable entries.
  3. Perform wiring:
    - Wiring diagram (aluminium housing) → Fig. 18
    - Wiring diagram (stainless steel housing) → Fig. 19
    - Wiring diagram (wall-mount housing) → Fig. 20
    - Terminal assignment → Seite 27
  4. Screw the cover of the connection compartment (f) back onto the transmitter housing.

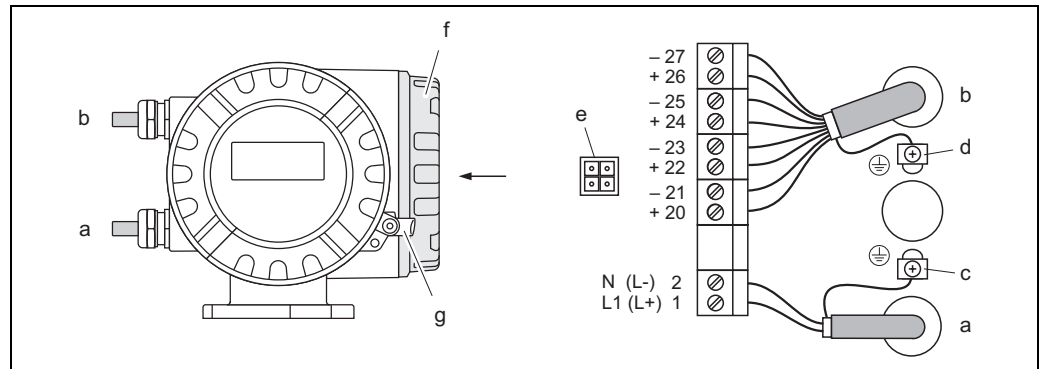

Fig. 18: Connecting the transmitter (aluminium field housing). Cable cross-section: max. 2.5 mm<sup>2</sup>

- a Cable for power supply: 85...260 V AC, 20...55 V AC, 16...62 V DC  
Terminal **No. 1:** L1 for AC, L+ for DC  
Terminal **No. 2:** N for AC, L- for DC
- b Signal cable: Terminals **Nos. 20-27** → Seite 27
- c Ground terminal for protective earth
- d Ground terminal for signal cable shield
- e Service adapter for connecting service interface FXA 193 (FieldCheck, ToF Tool - Fieldtool Package)
- f Cover of the connection compartment
- g Securing clamp

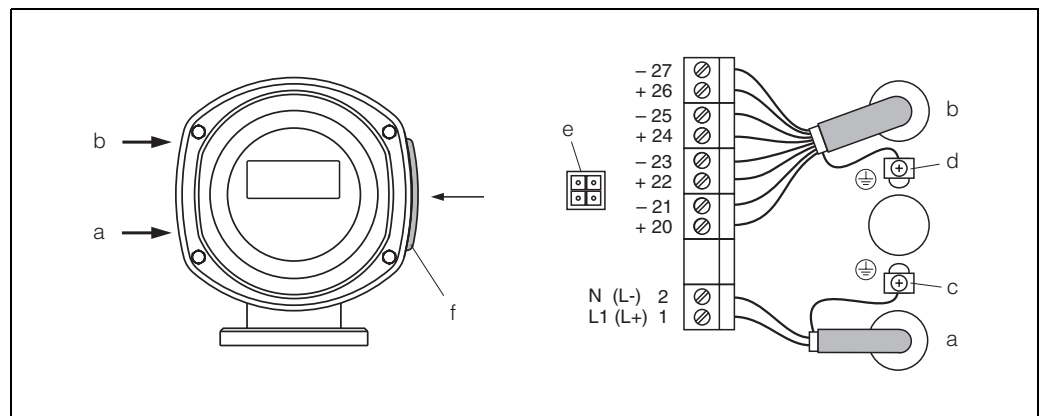

Fig. 19: Connecting the transmitter (stainless steel field housing); cable cross-section: max. 2.5 mm<sup>2</sup>

- a Cable for power supply: 85...260 V AC, 20...55 V AC, 16...62 V DC  
Terminal **No. 1:** L1 for AC, L+ for DC  
Terminal **No. 2:** N for AC, L- for DC
- b Signal cable: Terminals **Nos. 20-27** → Seite 27
- c Ground terminal for protective earth
- d Ground terminal for signal cable shield
- e Service adapter for connecting service interface FXA 193 (FieldCheck, ToF Tool - Fieldtool Package)
- f Cover of the connection compartment

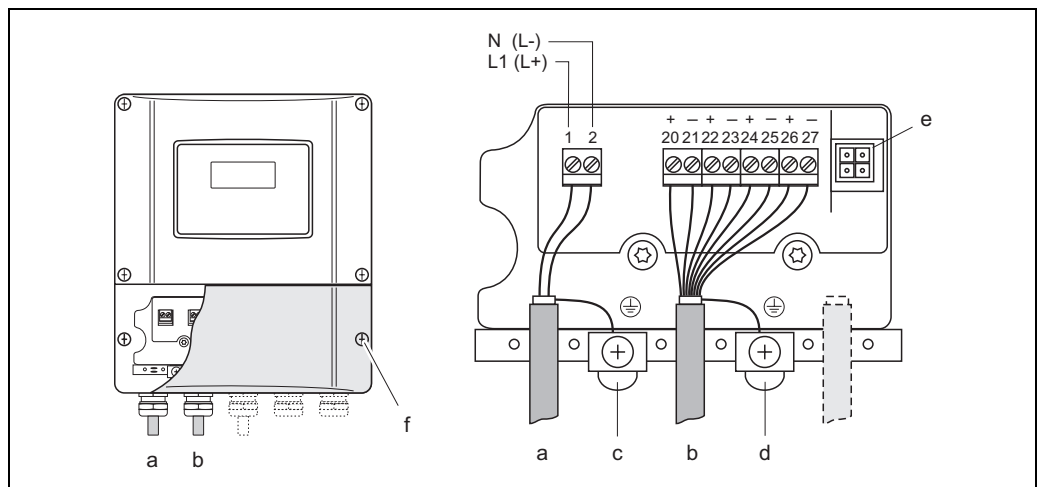

Fig. 20: Connecting the transmitter (wall-mount housing); cable cross-section: max. 2.5 mm<sup>2</sup>

- a Cable for power supply: 85...260 V AC, 20...55 V AC, 16...62 V DC  
Terminal **No. 1**: L1 for AC, L+ for DC  
Terminal **No. 2**: N for AC, L- for DC
- b Signal cable: Terminals **Nos. 20-27** → Seite 27
- c Ground terminal for protective earth
- d Ground terminal for signal cable shield
- e Service adapter for connecting service interface FXA 193 (FieldCheck, ToF Tool - Fieldtool Package)
- f Cover of the connection compartment

## 4.2.2 Terminal assignment

### Electrical values for inputs

→ Page 93

### Electrical values for outputs

→ Page 93

Order variant	Terminal No. (inputs/outputs)			
	20 (+) / 21 (-)	22 (+) / 23 (-)	24 (+) / 25 (-)	26 (+) / 27 (-)
<i>Flexible communication boards</i>				
84***_*****M	Status input	Frequency output 2	Frequency output 1	Current output HART

### 4.2.3 HART connection

Users have the following connection options at their disposal:

- Direct connection to transmitter by means of terminals 26(+) / 27(\*)
- Connection by means of the 4...20 mA circuit



Note!

- The measuring circuit's minimum load must be at least 250  $\Omega$ .
- The CURRENT SPAN function must be set to "4-20 mA" (individual options see device function).
- See also the documentation issued by the HART Communication Foundation, and in particular HCF LIT 20: "HART, a technical summary".

#### Connection of the HART handheld communicator

See also the documentation issued by the HART Communication Foundation, and in particular HCF LIT 20: "HART, a technical summary".

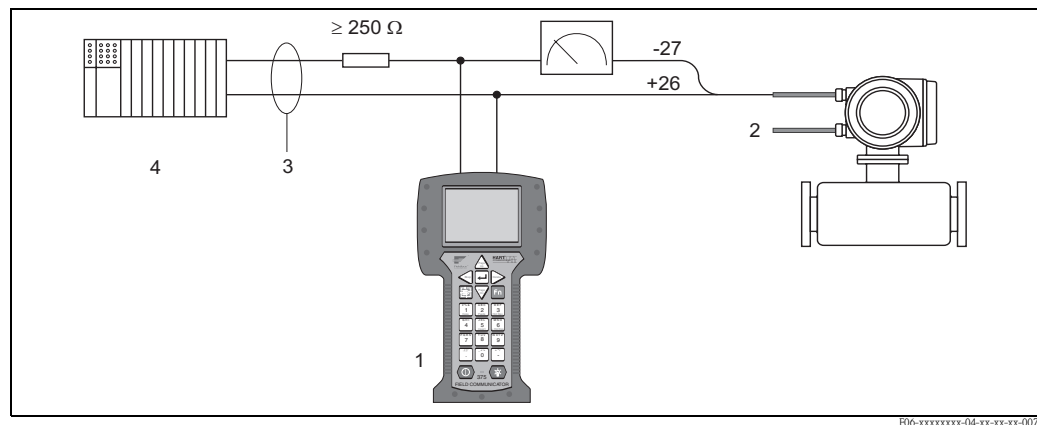

Fig. 21: Electrical connection of HART handheld terminal

- 1 HART handheld terminal
- 2 Auxiliary energy
- 3 Shielding
- 4 Other switching units or PLC with passive input

#### Connection of a PC with an operating software

In order to connect a PC with operating software (e.g. "ToF Tool - Fieldtool Package"), a HART modem (e.g. "Commubox FXA 191") is needed.

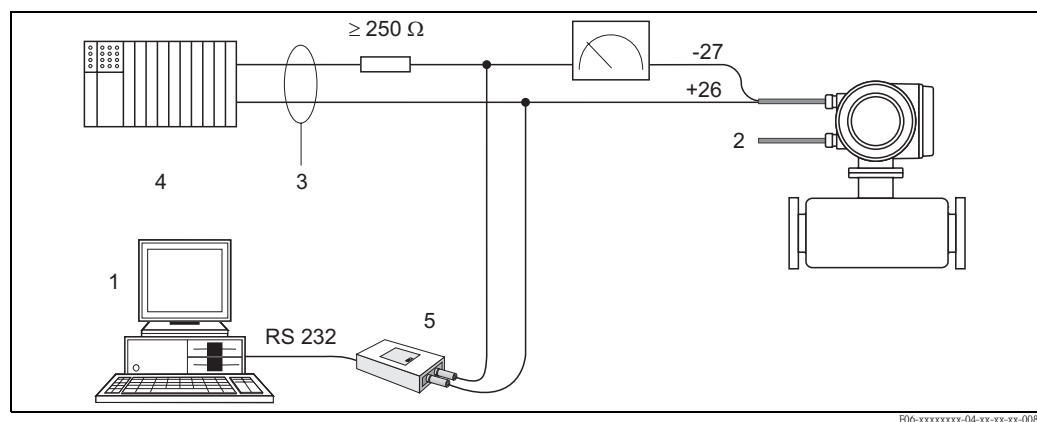

Fig. 22: Electrical connection of a PC with operating software

- 1 PC with operating software
- 2 Auxiliary energy
- 3 Shielding
- 4 Other switching units or PLC with passive input
- 5 HART modem, e.g. Commubox FXA 191

### 4.3 Degree of protection

The devices fulfill all the requirements for IP 67.

Compliance with the following points is mandatory following installation in the field or servicing, in order to ensure that IP 67 protection is maintained:

- The housing seals must be clean and undamaged when inserted into their grooves. The seals must be dried, cleaned or replaced if necessary.
- All threaded fasteners and screw covers must be firmly tightened.
- The cables used for connection must be of the specified outside diameter. → Page 94; Cable entry
- Firmly tighten the cable entries.
- The cables must loop down before they enter the cable entries (“water trap”). This arrangement prevents moisture penetrating the entry. Always install the measuring device in such a way that the cable entries do not point up.
- Remove all unused cable entries and insert plugs instead.
- Do not remove the grommet from the cable entry.

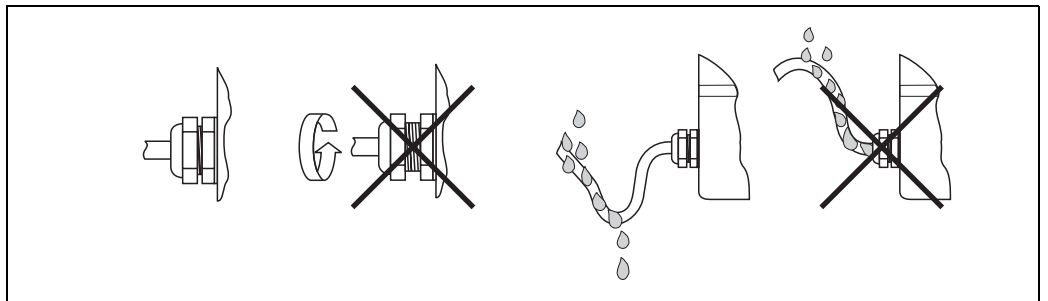

Fig. 23: Installation instructions, cable entries

a0001914

## 4.4 Post-connection check

Perform the following checks after completing electrical installation of the measuring device:

Device condition and specifications	Notes
Are cables or the device damaged (visual inspection)?	-
Electrical connection	Notes
Does the supply voltage match the specifications on the nameplate?	85...260 V AC (45...65 Hz) 20...55 V AC (45...65 Hz) 16...62 V DC
Do the cables comply with the specifications?	→ Page 25
Do the cables have adequate strain relief?	-
Cables correctly segregated by type? Without loops and crossovers?	-
Are the power supply and signal cables correctly connected?	See the wiring diagram inside the cover of the terminal compartment
Are all screw terminals firmly tightened?	-
Are all cable entries installed, firmly tightened and correctly sealed? Cables looped as "water traps"?	→ Page 29
Are all housing covers installed and firmly tightened?	-

## 5 Operation

### 5.1 Display and operating elements

The local display enables you to read all important parameters directly at the measuring point and configure the device using the “Quick Setup” or the function matrix.

The display consists of four lines; this is where measured values and/or status variables (direction of flow, empty pipe, bar graph, etc.) are displayed. You can change the assignment of display lines to different variables to suit your needs and preferences (→ see the “Description of Device Functions” manual).

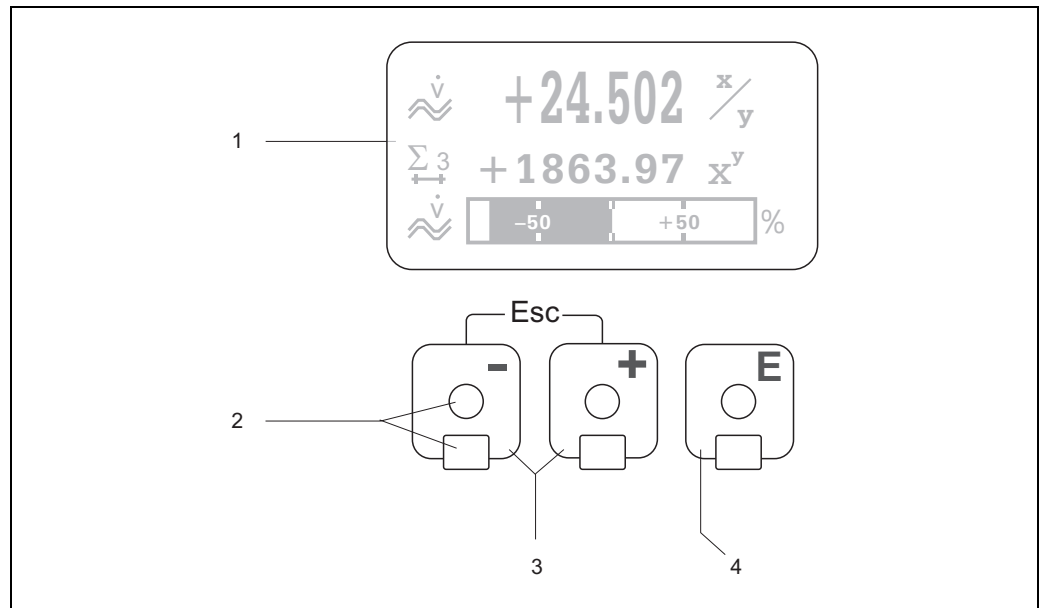

Fig. 24: Display and operating elements

- 1 **Liquid crystal display**  
The backlit, four-line liquid crystal display shows measured values, dialogue texts, fault messages and notice messages. HOME position (operating mode) is the term given to the display during normal operation.  
*Readings displayed*
- 2 **Optical sensors for "Touch Control"**
- 3 **Plus/minus keys**
  - HOME position → Direct access to totalizer values and actual values of inputs/outputs
  - Enter numerical values, select parameters
  - Select different blocks, groups and function groups within the function matrix*Press the +/- keys ( ) simultaneously to trigger the following functions:*
  - Exit the function matrix step by step → HOME position
  - Press and hold down +/- keys for longer than 3 seconds → Return directly to HOME position
  - Cancel data entry
- 4 **Enter key**
  - HOME position → Entry into the function matrix
  - Save the numerical values you input or settings you change

### 5.1.1 Readings displayed (operation mode)

The display area consists of three lines in all; this is where measured values are displayed, and/or status variables (direction of flow, bar graph, etc.). You can change the assignment of display lines to different variables to suit your needs and preferences (→ see the “Description of Device Functions” manual).

#### *Multiplex mode:*

A maximum of two different display variables can be assigned to each line. Variables multiplexed in this way alternate every 10 seconds on the display.

#### *Error messages:*

Display and presentation of system/process errors → Page 36

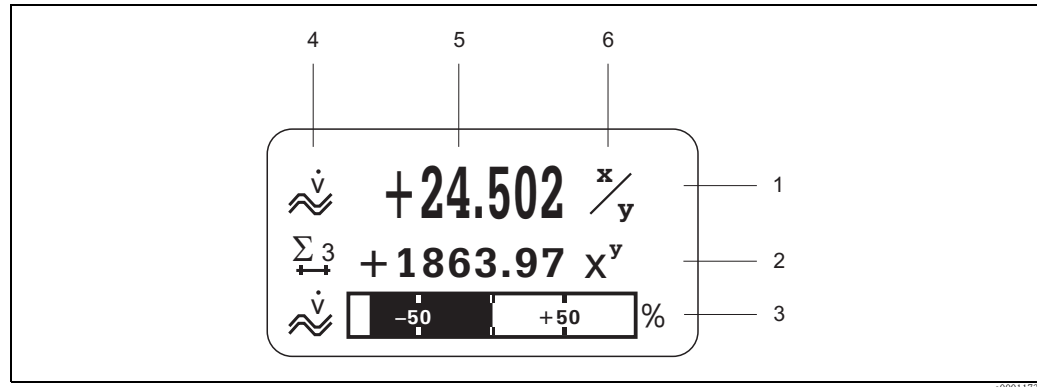

Fig. 25: Typical display for normal operating mode (HOME position)

- 1 Main display line: shows primary measured values, e.g. mass flow in [kg/h]
- 2 Additional line: shows measured variables and status variables, e.g. totalizer No. 3 in [t]
- 3 Information line: shows additional information on the measured variables and status variables, e.g. bargraph display of the full scale value achieved by the mass flow
- 4 “Info icons” field: Icons representing additional information on the measured values are shown in this field. For a full list of the icons and their meanings see
- 5 “Measured values” field: the current measured values appear in this field
- 6 “Unit of measure” field: the units of measure and time defined for the current measured values appear in this field

### 5.1.2 Additional display functions

Depending on the order options, the local display has different display functions.

#### **Device without batching software:**

From HOME position, use the +/- keys to open an “Info Menu” containing the following information:

- Totalizer (including overflow)
- Actual values or states of the configured inputs/outputs
- Device TAG number (user-definable)













→ Scan of individual values within the Info Menu

(Esc key) \* Back to HOME position



### 5.1.3 Icons

The icons which appear in the field on the left make it easier to read and recognise measured variables, device status, and error messages.

Icon	Meaning	Icon	Meaning
S	System error	P	Process error
⚡	Fault message (with effect on outputs)	!	Notice message (without effect on outputs)
I 1...n	Current output 1...n	P 1...n	Pulse output 1...n
F 1...n	Frequency output	Totalizer 1...n	$\Sigma$ 1...n
	Measuring mode; PULSATING FLOW		Measuring mode; SYMMETRY (bidirectional)
	Measuring mode; STANDARD		Counting mode, totalizer; BALANCE (forward and reverse flow)
	Counting mode, totalizer; forward		Counting mode, totalizer; reverse
	Status input		Volume flow
	Mass flow		Fluid density
	Reference density		Fluid temperature
	Remote configuration Active device operation via: <ul style="list-style-type: none"> <li>■ HART, e.g. ToF Tool - Fieldtool Package, DXR 375</li> <li>■ FOUNDATION Fieldbus</li> <li>■ PROFIBUS</li> </ul>		

## 5.2 Brief operating instructions to the function matrix



Note!

- See the general notes → Page 35
  - Function descriptions → see the “Description of Device Functions” manual
1. HOME position → **E** → Entry into the function matrix
  2. Select a block (e.g. OUTPUTS)
  3. Select a group (e.g. CURRENT OUTPUT 1)
  4. Select a function group (e.g. SETTINGS)
  5. Select a function (e.g. TIME CONSTANT)  
Change parameter / enter numerical values:
    - Select or enter enable code, parameters, numerical values
    - E** → Save your entries
  6. Exit the function matrix:
    - Press and hold down Esc key () for longer than 3 seconds → HOME position
    - Repeatedly press Esc key () → Return step by step to HOME position

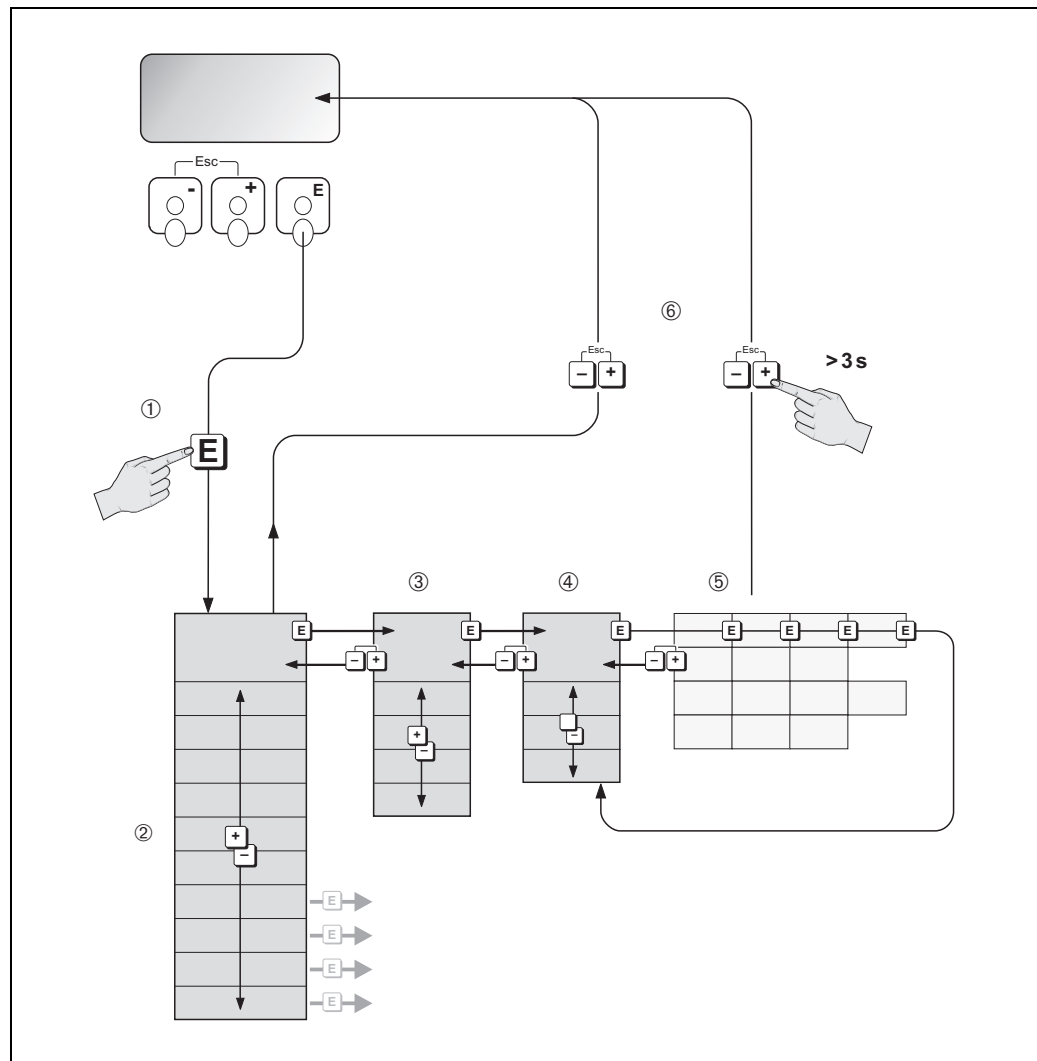



Fig. 26: Selecting functions and configuring parameters (function matrix)

### 5.2.1 General notes

The Quick Setup menu contains the default settings that are adequate for commissioning. Complex measuring operations on the other hand necessitate additional functions that you can configure as necessary and customise to suit your process parameters. The function matrix, therefore, comprises a multiplicity of additional functions which, for the sake of clarity, are arranged on a number of menu levels (blocks, groups, and function groups).

Comply with the following instructions when configuring functions:

- You select functions as described already. → Page 34  
Each cell in the function matrix is identified by a numerical or letter code on the display.
- You can switch off certain functions (OFF). If you do so, related functions in other function groups will no longer be displayed.
- Certain functions prompt you to confirm your data entries. Press  to select “SURE [ YES ]” and press  to confirm. This saves your setting or starts a function, as applicable.
- Return to the HOME position is automatic if no key is pressed for 5 minutes.
- Programming mode is disabled automatically if you do not press a key within 60 seconds following automatic return to the HOME position.



Caution!

All functions are described in detail, as is the function matrix itself, in the “Description of Device Functions” manual, which is a separate part of these Operating Instructions.



Note!

- The transmitter continues to measure while data entry is in progress, i.e. the current measured values are output via the signal outputs in the normal way.
- If the supply voltage fails all preset and parameterised values remain safely stored in the EEPROM.

### 5.2.2 Enabling the programming mode

The function matrix can be disabled. Disabling the function matrix rules out the possibility of inadvertent changes to device functions, numerical values or factory settings. A numerical code (factory setting = 84) has to be entered before settings can be changed.

If you use a code number of your choice, you exclude the possibility of unauthorised persons accessing data (→ see the “Description of Device Functions” manual).

Comply with the following instructions when entering codes:

- If programming is disabled and the  operating elements are pressed in any function, a prompt for the code automatically appears on the display.
- If “0” is entered as the customer's code, programming is always enabled!
- The Endress+Hauser service organisation can be of assistance if you mislay your personal code.



Caution!

Changing certain parameters such as all sensor characteristics, for example, influences numerous functions of the entire measuring system, particularly measuring accuracy.

There is no need to change these parameters under normal circumstances and consequently, they are protected by a special code known only to the Endress+Hauser service organisation. Please contact Endress+Hauser if you have any questions.

### 5.2.3 Disabling the programming mode

Programming mode is disabled if you do not press an operating element within 60 seconds following automatic return to the HOME position.

You can also disable programming in the “ACCESS CODE” function by entering any number (other than the customer's code).

## 5.3 Error messages

### 5.3.1 Type of error

Errors that occur during commissioning or measuring are displayed immediately. If two or more system or process errors occur, the error with the highest priority is the one shown on the display.

The measuring system distinguishes between two types of error:

- *System error*: This group includes all device errors, e.g. communication errors, hardware errors, etc. → Page 76
- *Process error*: This group includes all application errors, e.g. fluid not homogeneous, etc. → Page 80

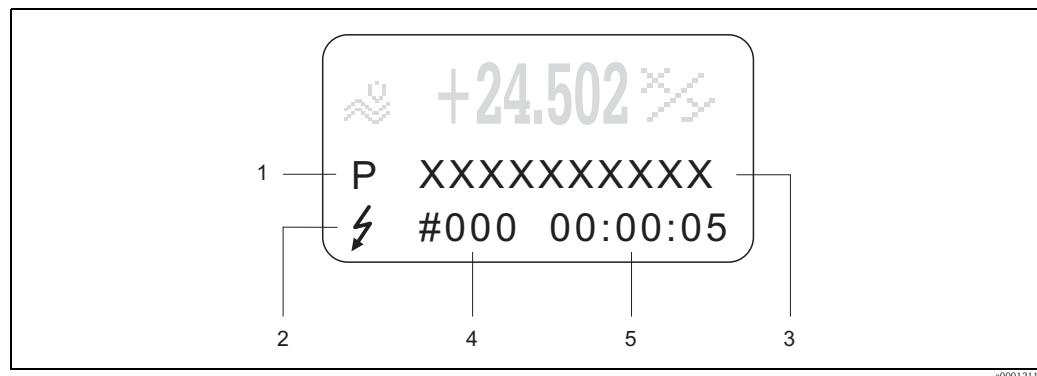

Fig. 27: Error messages on the display (example)

- 1 Error type: P = process error, S = system error
- 2 Error message type: ⚡ = Fault message, ! = Notice message
- 3 Error designation: e.g. FLUID INHOM. = fluid is not homogeneous
- 4 Error number: e.g. #702
- 5 Duration of most recent error occurrence (in hours, minutes and seconds)

### 5.3.2 Error message type

Users have the option of weighting system and process errors differently, by defining them as **Fault messages** or **Notice messages**. You can define messages in this way with the aid of the function matrix (see the “Description of Device Functions” manual).

Serious system errors, e.g. module defects, are always identified and classed as “fault messages” by the measuring device.

Notice message (!)

- Displayed as → Exclamation mark (!), error designation (S: system error, P: process error)
- The error in question has no effect on the outputs of the measuring device.

Fault message (⚡)

- Displayed as → Lightning flash (⚡), error designation (S: system error, P: process error).
- The error in question has a direct effect on the outputs.

The response of the outputs (failsafe mode) can be defined by means of functions in the function matrix. → Page 82



Note!

- Error conditions can be output via the relay outputs.
- If an error message occurs, an upper or lower signal level for the breakdown information according to NAMUR 43 can be output via the current output.

### 5.3.3 Confirming error messages

For the sake of plant and process safety, the measuring device can be configured in such a way that fault messages displayed (⚡) always have to be rectified and acknowledged locally by pressing . Only then do the error messages disappear from the display.

This option can be switched on or off by means of the “ACKNOWLEDGE FAULT MESSAGES” function (see the “Description of Device Functions” manual).



Note!

- Fault messages (⚡) can also be reset and confirmed via the status input.
- Notice messages (!) do not require acknowledgement. Note, however, that they remain visible until the cause of the error has been rectified.

## 5.4 Communication

In addition to local operation, the measuring device can be configured and measured values can be obtained by means of the HART protocol. Digital communication takes place using the 4-20 mA current output HART → Page 28.

The HART protocol allows the transfer of measuring and device data between the HART master and the field devices for configuration and diagnostics purposes. The HART master, e.g. a handheld terminal or PC-based operating programs (such as ToF Tool - Fieldtool Package), require device description (DD) files which are used to access all the information in a HART device. Information is exclusively transferred using so-called "commands". There are three different command groups:

There are three different command groups:

- *Universal Commands*

These are associated with the following functionalities for example: Universal commands are supported and used by all HART devices.

- Recognizing HART devices
- Reading digital measured values (volume flow, totalizer, etc.)

- *Common practice commands:*

Common practice commands offer functions which are supported and can be executed by most but not all field devices.

- *Device-specific commands:*

These commands allow access to device-specific functions which are not HART standard. Such commands access individual field device information, amongst other things, such as empty/full pipe calibration values, low flow cut off settings, etc.



Note!

The measuring device has access to all three command classes.

List of all "Universal Commands" and "Common Practice Commands": → Page 41

### 5.4.1 Operating options

For the complete operation of the measuring device, including device-specific commands, there are DD files available to the user to provide the following operating aids and programs:



Note!

- In the CURRENT RANGE function (current output 1), the HART protocol demands the setting “4...20 mA HART” or “4-20 mA (25 mA) HART”.
- HART write protection can be disabled or enabled by means of a jumper on the I/O board.  
→ Page 51

#### **HART handheld terminal DXR 375**

Selecting device functions with a HART Communicator is a process involving a number of menu levels and a special HART function matrix.

The HART manual in the carrying case of the HART Communicator contains more detailed information on the device.

#### **Operating program “ToF Tool - Fieldtool Package”**

Modular software package consisting of the service program “ToF Tool” for configuration and diagnosis of ToF level measuring devices (time-of-flight measurement) and evolution of pressure measuring instruments as well as the "Fieldtool" service program for the configuration and diagnosis of Proline flowmeters. The Proline flowmeters are accessed via a service interface or via the service interface FXA 193 or the HART protocol.

Contents of the “ToF Tool - Fieldtool Package”:

- Commissioning, maintenance analysis
- Configuring flowmeters
- Service functions
- Visualisation of process data
- Trouble-shooting

#### **Fieldcare**

FieldCare is Endress+Hauser's FDT-based plant asset management tool and allows the configuration and diagnosis of intelligent field devices. By using status information, you also have a simple but effective tool for monitoring devices. The Proline flowmeters are accessed via a service interface or via the service interface FXA 193.

#### **Operating program “SIMATIC PDM” (Siemens)**

SIMATIC PDM is a standardised, manufacturer-independent tool for the operation, configuration, maintenance and diagnosis of intelligent field devices.

#### **Operating program “AMS” (Emerson Process Management)**

AMS (Asset Management Solutions): program for operating and configuring devices

### 5.4.2 Current device description files

The following table illustrates the suitable device description file for the operating tool in question and then indicates where these can be obtained.

HART protocol:

<b>Valid for software:</b>	2.00.XX	→ Function "Device software" (8100)
<b>Device data HART</b>		
Manufacturer ID:	11 <sub>hex</sub> (ENDRESS+HAUSER)	→ Function "Manufacturer ID" (6040)
Device ID:	52 <sub>hex</sub>	→ Function "Device ID" (6041)
<b>HART version data:</b>	Device Revision 6/ DD Revision 1	
<b>Software release:</b>	11.2004	
<b>Operating program:</b>	<b>Sources for obtaining device descriptions:</b>	
Handheld terminal DXR 375	<ul style="list-style-type: none"> <li>■ Use update function of handheld terminal</li> </ul>	
ToF Tool - Fieldtool Package Update	<ul style="list-style-type: none"> <li>■ <a href="http://www.tof-fieldtool.endress.com">www.tof-fieldtool.endress.com</a> (→ Download → Software → Updates)</li> <li>■ Update CD-ROM (Endress+Hauser order number 50099820)</li> </ul>	
Fieldcare / DTM	<ul style="list-style-type: none"> <li>■ <a href="http://www.endress.com">www.endress.com</a> (→ Download → Software → Driver)</li> <li>■ CD-ROM (Endress+Hauser order number 56004088)</li> </ul>	
AMS	<ul style="list-style-type: none"> <li>■ <a href="http://www.endress.com">www.endress.com</a> (→ Download → Software → Driver)</li> </ul>	
SIMATIC PDM	<ul style="list-style-type: none"> <li>■ <a href="http://www.endress.com">www.endress.com</a> (→ Download → Software → Driver)</li> </ul>	

Operation via the service protocol

<b>Valid for device software:</b>	2.00.XX	→ Function "Device software" (8100)
<b>Software release:</b>	11.2004	
<b>Operating program:</b>	<b>Sources for obtaining device descriptions:</b>	
ToF Tool - Fieldtool Package	<ul style="list-style-type: none"> <li>■ <a href="http://www.tof-fieldtool.endress.com">www.tof-fieldtool.endress.com</a> (→ Download → Software → Device driver)</li> <li>■ Updates CD-ROM (Endress+Hauser order number 50099820)</li> </ul>	

### 5.4.3 Device and process variables

*Device variables:*

The following device variables are available using the HART protocol:

Code (decimal)	Device variable
0	OFF (unassigned)
2	Mass flow
5	Volume flow
6	Corrected volume flow
7	Density
8	Reference density
9	Temperature
250	Totalizer 1
251	Totalizer 2
252	Totalizer 3

*Process variables:*

At the factory, the process variables are assigned to the following device variables:

- Primary process variable (PV) → Mass flow
- Second process variable (SV) → Totalizer 1
- Third process variable (TV) → Density
- Fourth process variable (FV) → Temperature





Note!





You can set or change the assignment of device variables to process variables using Command 51 → Page 44.



### 5.4.4 Universal / Common practice HART commands



The following table contains all the universal commands supported by the device.



Command No. HART command / Access type		Command data (numeric data in decimal form)	Response data (numeric data in decimal form)
<b>Universal Commands</b>			
0	Read unique device identifier Access type = read	none	<p>Device identification delivers information on the device and the manufacturer. It cannot be changed.</p> <p>The response consists of a 12 - byte- device ID:</p> <ul style="list-style-type: none"> <li>– Byte 0: Fixed value 254</li> <li>– Byte 1: Manufacturer ID, 17 = E+H</li> <li>– Byte 2: Device type ID, e.g. 82 = Promass 84</li> <li>– Byte 3: Number of preambles</li> <li>– Byte 4: Universal commands rev. no.</li> <li>– Byte 5: Device-spec. commands rev. no.</li> <li>– Byte 6: Software revision</li> <li>– Byte 7: Hardware revision</li> <li>– Byte 8: Additional device information</li> <li>– Byte 9-11: Device identification</li> </ul>
1	Read primary process variable Access type = read	none	<ul style="list-style-type: none"> <li>– Byte 0: HART unit code of the primary process variable</li> <li>– Bytes 1-4: Primary process variable</li> </ul> <p><i>Factory setting:</i> Primary process variable = Mass flow</p> <p> <b>Note!</b></p> <ul style="list-style-type: none"> <li>■ Die You can set the assignment of device variables to process variables using Command 51.</li> <li>■ Manufacturer-specific units are represented using the HART unit code "240".</li> </ul>
2	Read the primary process variable as current in mA and percentage of the set measuring range Access type = read	none	<ul style="list-style-type: none"> <li>– Byte 0-3: Actual current of the primary process variable in mA</li> <li>– Bytes 4-7: Percentage of the set measuring range</li> </ul> <p><i>Factory setting:</i> Primary process variable = Mass flow</p> <p> <b>Note!</b> You can set the assignment of device variables to process variables using Command 51.</p>
3	Read the primary process variable as current in mA and four (preset using Command 51) dynamic process variables Access type = read	none	<p>24 bytes are sent as a response:</p> <ul style="list-style-type: none"> <li>– Bytes 0-3: Primary process variable current in mA</li> <li>– Byte 4: HART unit code of the primary process variable</li> <li>– Bytes 5-8: Primary process variable</li> <li>– Byte 9: HART unit code of the second process variable</li> <li>– Bytes 10-13: Second process variable</li> <li>– Byte 14: HART unit code of the third process variable</li> <li>– Bytes 15-18: Third process variable</li> <li>– Byte 19: HART unit code of the fourth process variable</li> <li>– Bytes 20-23: Fourth process variable</li> </ul> <p><i>Factory setting:</i></p> <ul style="list-style-type: none"> <li>■ Primary process variable = Mass flow</li> <li>■ Second process variable = Totalizer 1</li> <li>■ Third process variable = Density</li> <li>■ Fourth process variable = Temperature</li> </ul> <p> <b>Note!</b></p> <ul style="list-style-type: none"> <li>■ Die You can set the assignment of device variables to process variables using Command 51.</li> <li>■ Manufacturer-specific units are represented using the HART unit code "240".</li> </ul>



Command No. HART command / Access type		Command data (numeric data in decimal form)	Response data (numeric data in decimal form)
6	Set HART shortform address Access type = write	Byte 0: desired address (0...15) <i>Factory setting:</i> 0  Note! With an address >0 (multidrop mode), the current output of the primary process variable is set to 4 mA.	Byte 0: active address
11	Read unique device identification using the TAG (measuring point designation) Access type = read	Bytes 0-5: TAG	Device identification delivers information on the device and the manufacturer. It cannot be changed. The response consists of a 12-byte-device ID if the given TAG agrees with the one saved in the device: – Byte 0: Fixed value 254 – Byte 1: Manufacturer ID, 17 = E+H – Byte 2: Device type ID, 82 = Promass 84 – Byte 3: Number of preambles – Byte 4: Universal commands rev. no. – Byte 5: Device-spec. commands rev. no. – Byte 6: Software revision – Byte 7: Hardware revision – Byte 8: Additional device information – Byte 9-11: Device identification
12	Read user message Access type = read	none	Bytes 0-24: User message  Note! You can write the user message using Command 17.
13	Read TAG, descriptor and date Access type = read	none	– Bytes 0-5: TAG – Bytes 6-17: Descriptor – Byte 18-20: Date  Note! You can write the TAG, descriptor and date using Command 18.
14	Read sensor information on primary process variable	none	– Bytes 0-2: Sensor serial number – Byte 3: HART unit code of sensor limits and measuring range of the primary process variable – Bytes 4-7: Upper sensor limit – Bytes 8-11: Lower sensor limit – Bytes 12-15: Minimum span  Note! ■ Die The data relate to the primary process variable (= Mass flow). ■ Manufacturer-specific units are represented using the HART unit code "240".
15	Read output information of primary process variable Access type = read	none	– Byte 0: Alarm selection ID – Byte 1: Transfer function ID – Byte 2: HART unit code for the set measuring range of the primary process variable – Bytes 3-6: Upper range, value for 20 mA – Bytes 7-10: Start of measuring range, value for 4 mA – Bytes 11-14: Attenuation constant in [s] – Byte 15: Write protection ID – Byte 16: OEM dealer ID, 17 = E+H <i>Factory setting:</i> Primary process variable = Mass flow  Note! ■ You can set the assignment of device variables to process variables using Command 51. ■ Manufacturer-specific units are represented using the HART unit code "240".
16	Read the device production number Access type = read	none	Bytes 0-2: Production number

Command No. HART command / Access type		Command data (numeric data in decimal form)	Response data (numeric data in decimal form)
17	Write user message Access = write	You can save any 32-character long text in the device under this parameter: Bytes 0-23: Desired user message	Displays the current user message in the device: Bytes 0-23: Current user message in the device
18	Write TAG, descriptor and date Access = write	With this parameter, you can store an 8 character TAG, a 16 character descriptor and a date: – Bytes 0-5: TAG – Bytes 6-17: Descriptor – Byte 18-20: Date	Displays the current information in the device: – Bytes 0-5: TAG – Bytes 6-17: Descriptor – Byte 18-20: Date

The following table contains all the common practice commands supported by the device.

Command No. HART command / Access type		Command data (numeric data in decimal form)	Response data (numeric data in decimal form)
<b>Common Practice Commands</b>			
34	Write damping value for primary process variable Access = write	Bytes 0-3: Damping value of the primary process variable in seconds  <i>Factory setting:</i> Primary process variable = Mass flow	Displays the current damping value in the device: Bytes 0-3: Damping value in seconds
35	Write measuring range of primary process variable Access = write	Write the desired measuring range: – Byte 0: HART unit code of the primary process variable – Bytes 1-4: Upper range, value for 20 mA – Bytes 5-8: Start of measuring range, value for 4 mA  <i>Factory setting:</i> Primary process variable = Mass flow   <b>Note!</b> ■ Die You can set the assignment of device variables to process variables using Command 51. ■ If the HART unit code is not the correct one for the process variable, the device will continue with the last valid unit.	The currently set measuring range is displayed as a response: – Byte 0: HART unit code for the set measuring range of the primary process variable – Bytes 1-4: Upper range, value for 20 mA – Bytes 5-8: Start of measuring range, value for 4 mA   <b>Note!</b> Manufacturer-specific units are represented using the HART unit code "240".
38	Device status reset (Configuration changed) Access = write	none	none
40	Simulate output current of primary process variable Access = write	Simulation of the desired output current of the primary process variable. An entry value of 0 exits the simulation mode: Byte 0-3: Output current in mA  <i>Factory setting:</i> Primary process variable = Mass flow   <b>Note!</b> You can set the assignment of device variables to process variables with Command 51.	The momentary output current of the primary process variable is displayed as a response: Byte 0-3: Output current in mA
42	Perform master reset Access = write	none	none

Command No. HART command / Access type		Command data (numeric data in decimal form)	Response data (numeric data in decimal form)
44	Write unit of primary process variable Access = write	Set unit of primary process variable. Only unit which are suitable for the process variable are transferred to the device: Byte 0: HART unit code <i>Factory setting:</i> Primary process variable = Mass flow  Note! <ul style="list-style-type: none"> <li>■ If the written HART unit code is not the correct one for the process variable, the device will continue with the last valid unit.</li> <li>■ If you change the unit of the primary process variable, this has no impact on the system units.</li> </ul>	The current unit code of the primary process variable is displayed as a response: Byte 0: HART unit code  Note! Manufacturer-specific units are represented using the HART unit code "240".
48	Read additional device status Access = read	none	The device status is displayed in extended form as the response: Coding: see table → Page 46
50	Read assignment of the device variables to the four process variables Access = read	none	Display of the current variable assignment of the process variables: <ul style="list-style-type: none"> <li>– Byte 0: Device variable code to the primary process variable</li> <li>– Byte 1: Device variable code to the second process variable</li> <li>– Byte 2: Device variable code to the third process variable</li> <li>– Byte 3: Device variable code to the fourth process variable</li> </ul> <i>Factory setting:</i> <ul style="list-style-type: none"> <li>■ Primary process variable: Code 1 for mass flow</li> <li>■ Second process variable: Code 250 for totalizer 1</li> <li>■ Third process variable: Code 7 for density</li> <li>■ Fourth process variable: Code 9 for temperature</li> </ul>  Note! You can set the assignment of device variables to process variables with Command 51.
51	Write assignments of the device variables to the four process variables Access = write	Setting of the device variables to the four process variables: <ul style="list-style-type: none"> <li>– Byte 0: Device variable code to the primary process variable</li> <li>– Byte 1: Device variable code to the second process variable</li> <li>– Byte 2: Device variable code to the third process variable</li> <li>– Byte 3: Device variable code to the fourth process variable</li> </ul> <i>Code of the supported device variables:</i> See data → Page 40 <i>Factory setting:</i> <ul style="list-style-type: none"> <li>■ Primary process variable = Mass flow</li> <li>■ Second process variable = Totalizer 1</li> <li>■ Third process variable = Density</li> <li>■ Fourth process variable = Temperature</li> </ul>	The variable assignment of the process variables is displayed as a response: <ul style="list-style-type: none"> <li>– Byte 0: Device variable code to the primary process variable</li> <li>– Byte 1: Device variable code to the second process variable</li> <li>– Byte 2: Device variable code to the third process variable</li> <li>– Byte 3: Device variable code to the fourth process variable</li> </ul>

Command No.	HART command / Access type	Command data (numeric data in decimal form)	Response data (numeric data in decimal form)
53	Write device variable unit Access = write	<p>This command sets the unit of the given device variables. Only those units which suit the device variable are transferred:</p> <ul style="list-style-type: none"> <li>– Byte 0: Device variable code</li> <li>– Byte 1: HART unit code</li> </ul> <p><i>Code of the supported device variables:</i> See data → Page 40</p> <p> Note!</p> <ul style="list-style-type: none"> <li>■ If the written unit is not the correct one for the device variable, the device will continue with the last valid unit.</li> <li>■ If you change the unit of the device variable, this has no impact on the system units.</li> </ul>	<p>The current unit of the device variables is displayed in the device as a response:</p> <ul style="list-style-type: none"> <li>– Byte 0: Device variable code</li> <li>– Byte 1: HART unit code</li> </ul> <p> Note! Manufacturer-specific units are represented using the HART unit code "240".</p>
59	Write number of preambles in response message Access = write	<p>This parameter sets the number of preambles which are inserted in the response messages:</p> <p>Byte 0: Number of preambles (2...20)</p>	<p>As a response, the current number of the preambles is displayed in the response message:</p> <p>Byte 0: Number of preambles</p>

### 5.4.5 Device status / Error messages

You can read the extended device status, in this case, current error messages, via Command “48”. The command delivers information which are partly coded in bits (see table below).



Note!

You can find a detailed explanation of the device status and error messages and their elimination on: → Page 76 ff.

Byte-bit	Error No.	Short error description → Page 75 ff.
0-0	001	Serious device error
0-1	011	Measuring amplifier has faulty EEPROM
0-2	012	Error when accessing data of the measuring amplifier EEPROM
0-3	not assigned	–
0-4	not assigned	–
0-5	not assigned	–
0-6	not assigned	–
0-7	not assigned	–
1-0	not assigned	–
1-1	031	S-DAT: Defective or missing
1-2	032	S-DAT: Error accessing saved values
1-3	041	T-DAT: Defective or missing
1-4	042	T-DAT: Error accessing saved values
1-5	051	I/O board and the amplifier board are not compatible.
1-6	not assigned	–
1-7	not assigned	–
2-0	not assigned	–
2-1	not assigned	–
2-2	not assigned	–
2-3	not assigned	–
2-4	not assigned	–
2-5	not assigned	–
2-6	not assigned	–
2-7	not assigned	–
3-0	not assigned	–
3-1	not assigned	–
3-2	not assigned	–
3-3	111	Totalizer checksum error
3-4	121	I/O board and the amplifier board (software versions) are not compatible.
3-5	not assigned	–
3-6	205	T-DAT: Data download not successful
3-7	206	T-DAT: Data upload not successful
4-0	not assigned	–
4-1	not assigned	–
4-2	not assigned	–
4-3	251	Internal communication fault on the amplifier board.
4-4	261	No data reception between amplifier and I/O board

Byte-bit	Error No.	Short error description → Page 75 ff.
4-5	not assigned	–
4-6	not assigned	–
4-7	not assigned	–
5-0	not assigned	–
5-1	not assigned	–
5-2	not assigned	–
5-3	not assigned	–
5-4	not assigned	–
5-5	not assigned	–
5-6	not assigned	–
5-7	339	
6-0	340	Flow buffer: The temporarily buffered flow portions (measuring mode for pulsating flow) could not be cleared or output within 60 seconds.
6-1	341	
6-2	342	
6-3	343	
6-4	344	Frequency buffer: The temporarily buffered flow portions (measuring mode for pulsating flow) could not be cleared or output within 60 seconds.
6-5	345	
6-6	346	
6-7	347	
7-0	348	Pulse buffer: The temporarily buffered flow portions (measuring mode for pulsating flow) could not be cleared or output within 60 seconds.
7-1	349	
7-2	350	
7-3	351	
7-4	352	Current output: The actual value for the flow lies outside the set limits.
7-5	353	
7-6	354	
7-7	355	
8-0	356	Frequency output: The actual value for the flow lies outside the set limits.
8-1	357	
8-2	358	
8-3	359	Pulse output: Pulse output frequency is out of range.
8-4	360	
8-5	361	
8-6	362	
8-7	not assigned	–
9-0	379	The measuring tube oscillation frequency is outside the permitted range.
9-1	380	
9-2	381	The temperature sensor on the measuring tube is likely defective.
9-3	382	
9-4	383	The temperature sensor on the carrier tube is likely defective.
9-5	384	

Byte-bit	Error No.	Short error description → Page 75 ff.
9-6	385	Sensor coils probably defective
9-7	386	
10-0	387	
10-1	388	Amplifier error
10-2	389	
10-3	390	
10-4	not assigned	–
10-5	not assigned	–
10-6	not assigned	–
10-7	not assigned	–
11-0	not assigned	–
11-1	not assigned	–
11-2	not assigned	–
11-3	not assigned	–
11-4	not assigned	–
11-5	not assigned	–
11-6	471	Max. permitted batching time has been exceeded.
11-7	472	Underbatching: the minimum quantity was not reached. Overbatching: the maximum permitted batching quantity was exceeded.
12-0	473	The predefined batch quantity point was exceeded. End of filling process approaching.
12-1	474	Maximum flow value entered is overshoot.
12-2	not assigned	–
12-3	not assigned	–
12-4	not assigned	–
12-5	not assigned	–
12-6	not assigned	–
12-7	501	New amplifier software version is loaded. Currently no other commands are possible.
13-0	502	Upload and download of device files. Currently no other commands are possible.
13-1	not assigned	–
13-2	571	Batching process in progress (valves are open)
13-3	572	Batching process has been stopped (valves are closed)
13-4	not assigned	–
13-5	586	The fluid properties do not allow normal measuring operation.
13-6	587	Extreme process conditions exist. The measuring system can therefore not be started.
13-7	588	Overdriving of the internal analog to digital converter. A continuation of the measurement is no longer possible!
14-0	not assigned	–
14-1	not assigned	–
14-2	not assigned	–
14-3	601	Positive zero return active
14-4	not assigned	–
14-5	not assigned	–



Byte-bit	Error No.	Short error description → Page 75 ff.
14-6	not assigned	–
14-7	611	Simulation current output active
15-0	612	
15-1	613	
15-2	614	
15-3	621	Simulation frequency output active
15-4	622	
15-5	623	
15-6	624	
15-7	631	Simulation pulse output active
16-0	632	
16-1	633	
16-2	634	
16-3	641	Simulation status output active
16-4	642	
16-5	643	
16-6	644	
16-7	651	
17-0	652	
17-1	653	
17-2	654	
17-3	661	
17-4	662	
17-5	663	
17-6	664	
17-7	671	Simulation status input active
18-0	672	
18-1	673	
18-2	674	
18-3	691	Simulation of response to error (outputs) active
18-4	692	Simulation of volume flow active
18-5	not assigned	–
18-6	not assigned	–
18-7	not assigned	–
19-0	700	The process fluid density is outside the upper or lower limit values set in the “EPD” function
19-1	701	The maximum current value for the measuring tube exciter coils has been reached, since certain process fluid characteristics are extreme.
19-2	702	Frequency control is not stable, due to inhomogeneous fluid.
19-3	703	NOISE LIM. CH0 Overdriving of the internal analog to digital converter. A continuation of the measurement is still possible!
19-4	704	NOISE LIM. CH1 Overdriving of the internal analog to digital converter. A continuation of the measurement is still possible!

Byte-bit	Error No.	Short error description → Page 75 ff.
19-5	705	The electronics' measuring range will be exceeded. The mass flow is too high.
19-6	not assigned	–
19-7	not assigned	–
20-0	not assigned	–
20-1	not assigned	–
20-2	not assigned	–
20-3	not assigned	–
20-4	not assigned	–
20-5	731	The zero point adjustment is not possible or has been cancelled.
20-6	not assigned	–
20-7	not assigned	–
22-4	61	
24-5	363	

### 5.4.6 Switching HART write protection on and off

A jumper on the I/O board provides the means of switching HART write protection on or off.



**Warning!**

Risk of electric shock. Exposed components carry dangerous voltages. Make sure that the power supply is switched off before you remove the cover of the electronics compartment.

1. Switch off power supply.
2. Remove the I/O board → Page 84, → Page 86
3. Switch HART write protection on or off, as applicable, by means of the jumper (→ Fig. 28).
4. Installation of the I/O board is the reverse of the removal procedure.

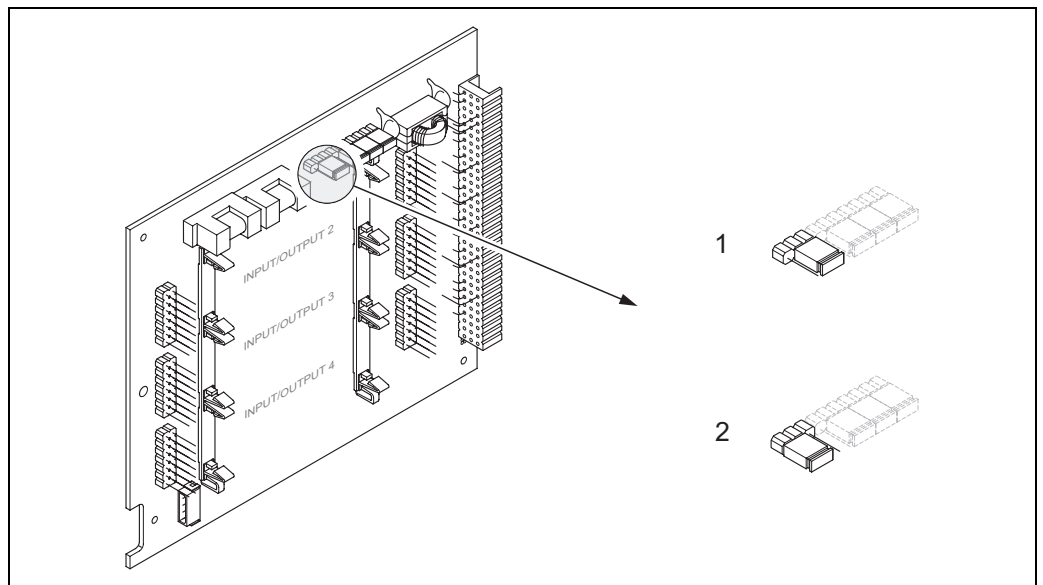

Fig. 28: Switching HART write protection on and off

- 1 Write protection OFF (default), that is: HART protocol unlocked
- 2 Write protection ON, that is: HART protocol locked

## 6 Commissioning

### 6.1 Function check

Make sure that all final checks have been completed before you start up your measuring point:

- Checklist for “Post-installation check” → Page 23
- Checklist for “Post-connection check” → Page 30

### 6.2 Switching on the measuring device

Once the post-connection checks have been successfully completed, it is time to switch on the supply voltage. The device is now operational.

The measuring device performs a number of power on self-tests. As this procedure progresses the following sequence of messages appears on the local display:

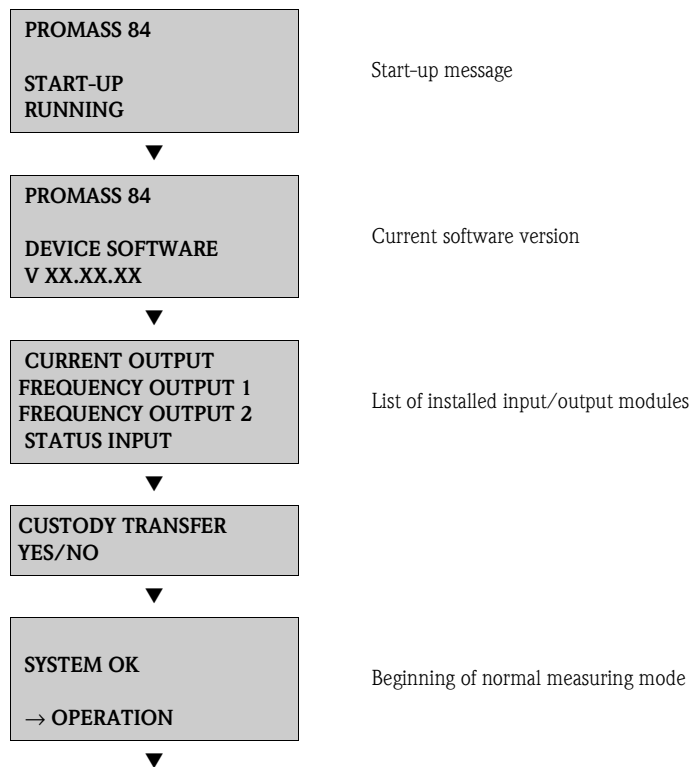

Normal measuring mode commences as soon as start-up completes. Various measured value and/or status variables appear on the display (HOME position).



Note!

If start-up fails, an error message indicating the cause is displayed.

## 6.3 Quick Setup

In the case of measuring devices without a local display, the individual parameters and functions must be configured via the configuration program, e.g. ToF Tool - Fieldtool Package. If the measuring device is equipped with a local display, all the important device parameters for standard operation can be configured quickly and easily by means of the "Commissioning" Quick Setup menu.

- Quick Setup "Commissioning", see below
- Quick Setup "Pulsating flow", → Page 55 ff.
- Quick Setup "Gas measurement", → Page 58 ff.

### 6.3.1 Quick Setup "Commissioning"



Note!

- The display returns to the cell SETUP COMMISSIONING (1002) if you press the ESC key combination during parameter interrogation. The stored parameters remain valid.
- The "Commissioning" Quick Setup must be carried out before one of the Quick Setups explained below is run.
- ① Only units not yet configured in the current Setup are offered for selection in each cycle.  
The unit for mass, volume and corrected volume is derived from the corresponding flow unit.
- ② The "YES" option remains visible until all the units have been configured.  
"NO" is the only option displayed when no further units are available.
- ③ Only the outputs not yet configured in the current Setup are offered for selection in each cycle.
- ④ The "YES" option remains visible until all the outputs have been parameterized.  
"NO" is the only option displayed when no further outputs are available.
- ⑤ The "automatic parameterization of the display" option contains the following basic settings/factory settings:  
YES: Main line = Mass flow; Additional line = Totalizer 1;  
Information line = Operating/system conditions  
NO: The existing (selected) settings remain.
- ⑥ The QUICK SETUP BATCHING is only available when the optional software package BATCHING is installed.

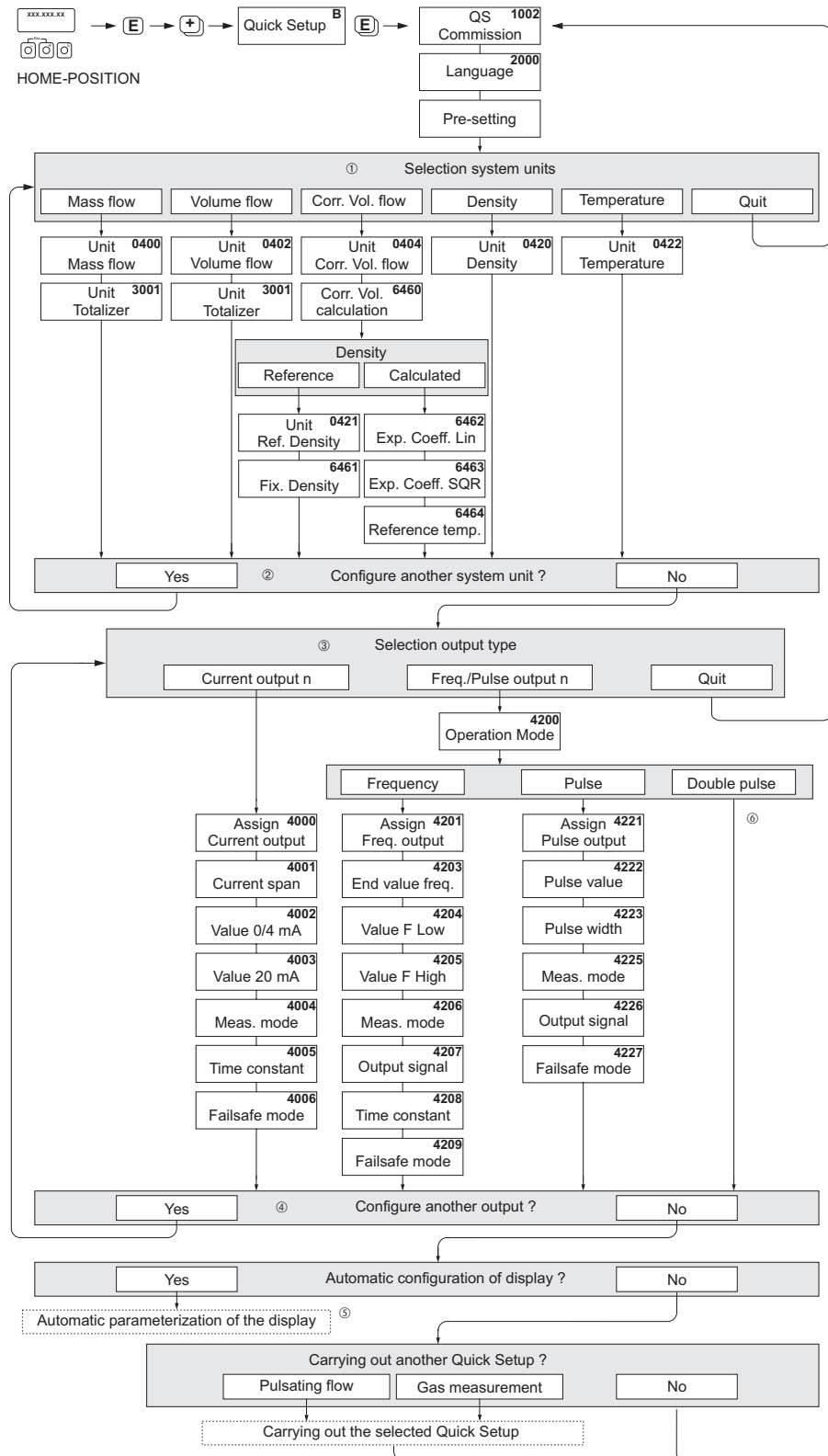

a0001786-en

Fig. 29: "QUICK SETUP COMMISSIONING"- menu for straightforward configuration of the major device functions

### 6.3.2 Quick Setup “Pulsating Flow”

Certain types of pump such as reciprocating, peristaltic and cam-type pumps, for example, create a flow characterised by severe periodic fluctuations. Negative flows can occur with pumps of these types on account of the closing volume of the valves or valve leaks.



Note!

Before carrying out the Quick Setup “Pulsating Flow” the Quick Setup “Commissioning” has to be executed. → Page 53

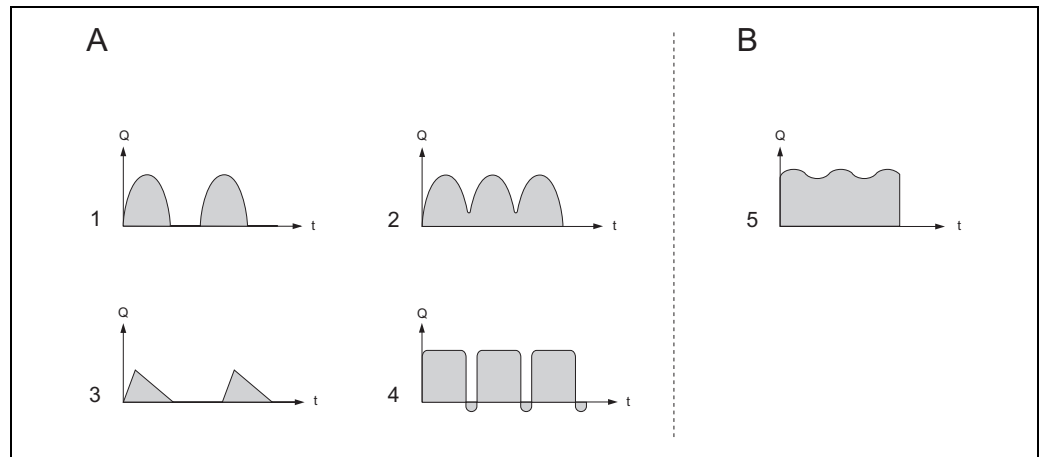

Fig. 30: Flow characteristics of various types of pump

- A With severely pulsating flow  
 B With low pulsating flow  
 1 1-cylinder cam pump  
 2 2-cylinder cam pump  
 3 Magnetic pump  
 4 Peristaltic pump, flexible connecting hose  
 5 Multi-cylinder reciprocating pump

#### Severely pulsating flow

Once several device functions have been configured in the “Pulsating flow” Quick Setup menu, flow fluctuations of this nature can be compensated over the entire flow range and pulsating fluid flows measured correctly. You will find detailed instructions on how to use this Quick Setup menu on the following pages.



Note!

It is always advisable to work through the “Pulsating flow” Quick Setup menu if there is any uncertainty about the exact flow characteristic.

#### Slightly pulsating flow

If flow fluctuations are no more than minor, as is the case, for example with gear-type, three-cylinder or multi-cylinder pumps, it is **not** absolutely necessary to work through the Quick Setup menu.

In cases of this nature, however, it is advisable to adapt the functions listed below in the function matrix (see the “Description of Device Functions” manual) to suit local process conditions in order to ensure a stable, unvarying output signal:

- Measuring system damping: "FLOW DAMPING" function. → Increase value
- Current output damping: TIME CONSTANT function \* increase the value

#### Performing the “Pulsating flow” Quick Setup

This Quick Setup menu guides you systematically through the setup procedure for all the device functions that have to be parameterised and configured for measuring pulsating flows. Note that this has no effect on values configured beforehand, such as measuring range, current range or full scale value.

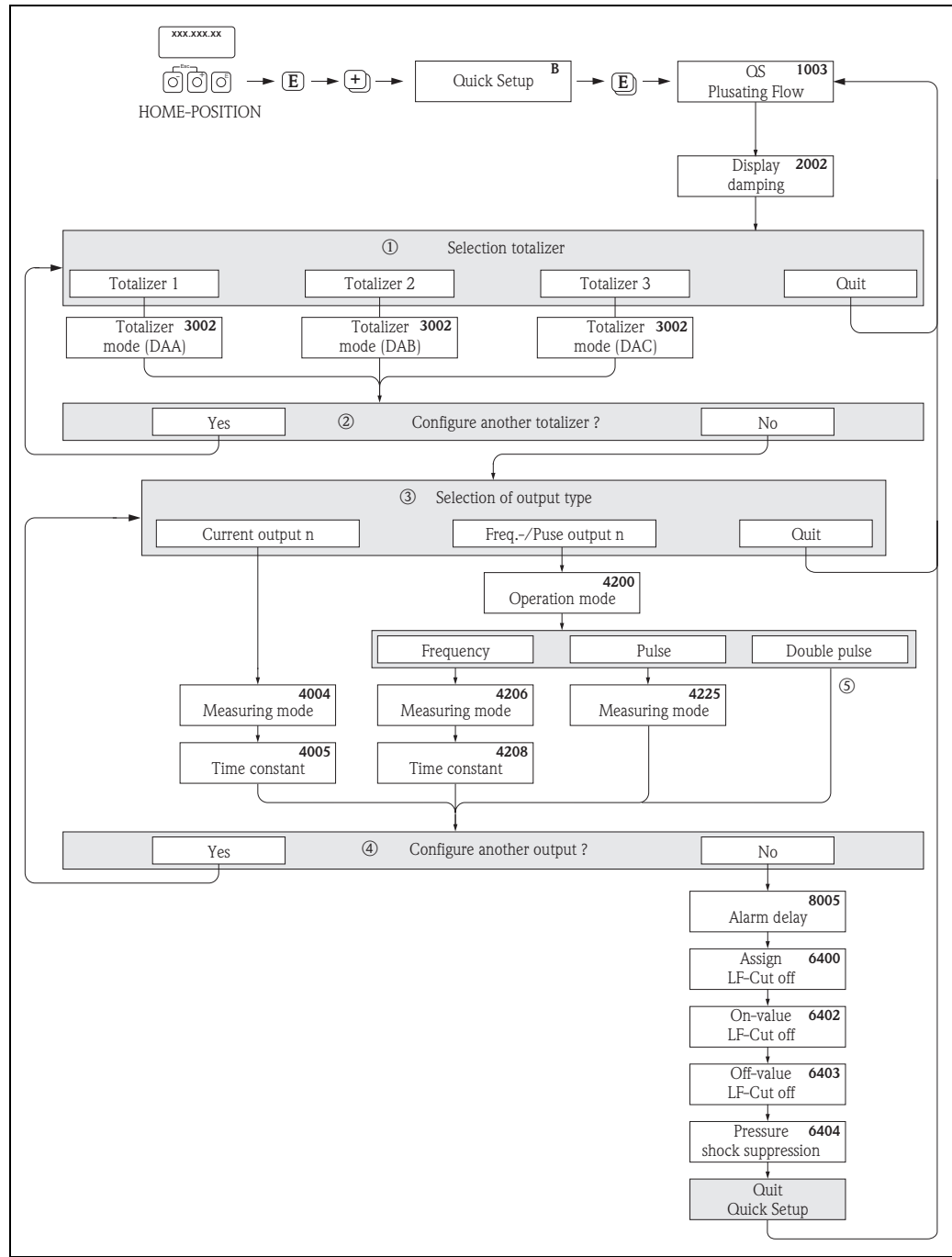

Fig. 31: Quick Setup for measuring severely pulsating flows.

Recommended settings are found on the following page.



#### Note!

- The display returns to the cell QUICK SETUP PULSATING FLOW (1003) if you press the ESC key combination during parameter interrogation.
- You can call up this Setup menu either directly from the "COMMISSIONING" Setup menu or manually by means of the function QUICK SETUP PULSATING FLOW (1003).
- ① Only totalizers not yet configured in the current Setup are offered for selection in each cycle.
- ② The "YES" option remains visible until all the totalizers have been parameterized. "NO" is the only option displayed when no further totalizers are available.
- ③ Only the outputs not yet configured in the current Quick Setup are offered for selection in each cycle.



- ④ The “YES” option remains visible until all the outputs have been parameterized.  
“NO” is the only option displayed when no further outputs are available.
- ⑤ The “DOUBLE PULS C.T.” function can only be selected for frequency output 2 and only if the "PULSE" operating mode was selected for frequency output 1.  
Frequency output 2 then works with the parameters selected by frequency output 1, but phase-shifted by 90°

<b>“Pulsating Flow” Quick Setup menu</b>		
HOME position →  → MEASURED VARIABLE (A) MEASURED VARIABLE →  → QUICK SETUP (B) QUICK SETUP →  → QS PULS. FLOW (1003)		
Function No.	Function name	Selection with (  )
1003	QS-PULS. FLOW	YES After  is pressed by way of confirmation, the Quick Setup menu calls up all the subsequent functions in succession.
▼		
<b>Basic configuration</b>		
2002	DISPLAY DAMPING	1 s
3002	TOTALIZER MODE (DAA)	BALANCE (Totalizer 1)
3002	TOTALIZER MODE (DAB)	BALANCE (Totalizer 2)
3002	TOTALIZER MODE (DAC)	BALANCE (Totalizer 3)
<b>Signal type for “CURRENT OUTPUT 1...n”</b>		
4004	MEASURING MODE	PULS. FLOW
4005	TIME CONSTANT	1 s
<b>Signal type for “FREQ./PULSE OUTPUT 1...n” (for FREQUENCY operating mode)</b>		
4206	MEASURING MODE	PULS. FLOW
4208	TIME CONSTANT	0 s
<b>Signal type for “FREQ./PULSE OUTPUT 1...n” (for PULSE operating mode)</b>		
4225	MEASURING MODE	PULS. FLOW
<b>Other settings</b>		
8005	ALARM DELAY	0 s
6400	ASSIGN LOW FLOW CUTOFF	MASS FLOW
6402	ON-VALUE LOW FLOW CUT OFF	Setting depends on diameter: DN 1 = 0.02 [kg/h] or [l/h] DN 2 = 0.10 [kg/h] or [l/h] DN 4 = 0.45 [kg/h] or [l/h] DN 8 = 2.0 [kg/h] or [l/h] DN 15 = 6.5 [kg/h] or [l/h] DN 25 = 18 [kg/h] or [l/h] DN 40 = 45 [kg/h] or [l/h] DN 50 = 70 [kg/h] or [l/h] DN 80 = 180 [kg/h] or [l/h] DN 100 = 350 [kg/h] or [l/h] DN 150 = 650 [kg/h] or [l/h] DN 250 = 1800 [kg/h] or [l/h]
6403	OFF-VALUE LOW FLOW CUTOFF	50%
6404	PRESSURE SHOCK SUPPRESSION	0 s
▼		
Back to the HOME position: → Press and hold down Esc key  for longer than three seconds or → Repeatedly press and release Esc key  → Exit the function matrix step by step		

### 6.3.3 Quick Setup “Gas Measurement”

The measuring device is not only suitable for measuring liquid flow. Direct mass measurement based on the Coriolis principle is also possible for measuring the flow rate of gases.



Note!

- Before carrying out the Quick Setup “Gas measurement” the Quick Setup “Commissioning” has to be executed. → Page 53
- Only mass and Corrected volume flow can be measured and output with the gas measurement mode. Note that direct density and/or volume measurement is not possible!
- The flow ranges and measuring accuracy that apply to gas measurement are not the same as those for liquids.
- If corrected volume flow (e.g. in Nm<sup>3</sup>/h) is to be measured and output instead of the mass flow (e.g. in kg/h), change the setting for the CORRECTED VOLUME CALCULATION function to “FIXED REFERENCE DENSITY” in the “Commissioning” Quick Setup menu.

Corrected volume flow can be assigned as follows:

- to a display line
- to the current output
- to the pulse/frequency output.

#### Performing the “Gas Measurement” Quick Setup

This Quick Setup menu guides you systematically through the setup procedure for all the device functions that have to be parameterised and configured for gas measurement.

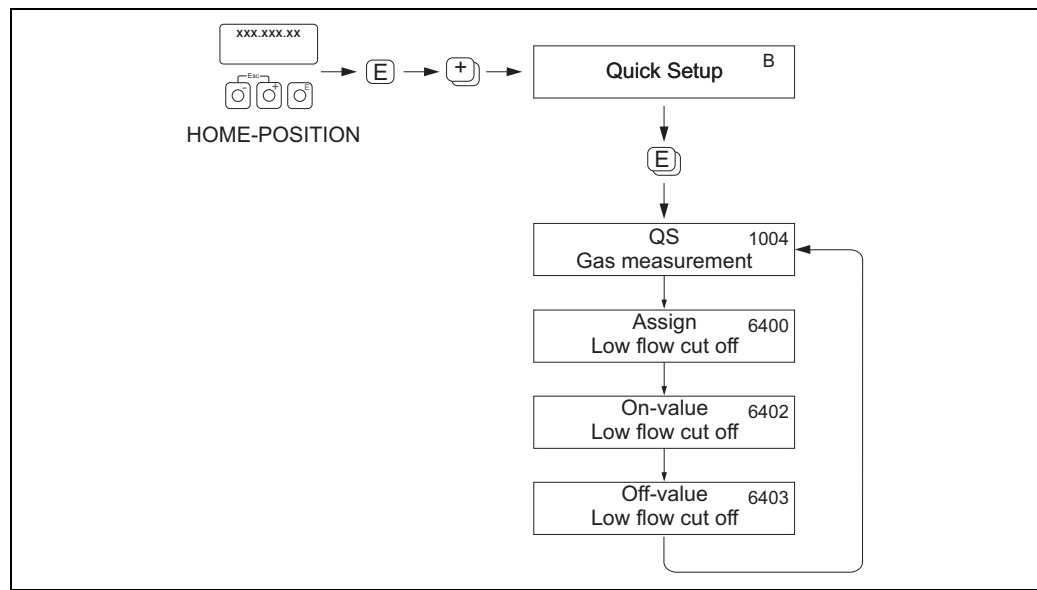









Fig. 32: "Gas Measurement" Quick Setup

Recommended settings are found on the following page.

"Gas Measurement" Quick Setup menu		
HOME position →  → MEASURED VARIABLE (A) MEASURED VARIABLE →  → QUICK SETUP (B) QUICK SETUP →  → QS-GAS MEASUREMENT (1004)		
Function No.	Function name	Setting to be selected (  ) (to next function with  )
1004	QS GAS MEASUREMENT	YES After  is pressed by way of confirmation, the Quick Setup menu calls up all the subsequent functions in succession.
▼		
6400	ASSIGN LOW FLOW CUTOFF	On account of the low mass flow involved when gas flows are measured, it is advisable not use a low flow cutoff. Setting: OFF
6402	ON-VALUE LOW FLOW CUT OFF	If the ASSIGNMENT LOW FLOW CUTOFF function was not set to "OFF", the following applies: Setting: 0.0000 [unit] User input: Flow rates for gas measurements are low, so the value for the switch-on point (= low flow cutoff) must be correspondingly low.
6403	OFF-VALUE LOW FLOW CUTOFF	If the ASSIGNMENT LOW FLOW CUTOFF function was not set to "OFF", the following applies: Setting: 50% User input: Enter the switch-off point as a positive hysteresis in %, referenced to the switch-on point.
▼		
Back to the HOME position: → Press and hold down Esc key  for longer than three seconds or → Repeatedly press and release Esc key  → Exit the function matrix step by step		



#### Note!

Quick Setup automatically deactivates the function EMPTY PIPE DETECTION (6420) so that the instrument can measure flow at low gas pressures.

### 6.3.4 Data back-up with "T-DAT SAVE/LOAD"

The "T-DAT SAVE/LOAD" function can be used to store all the settings and parameters of the device to the T-DAT data storage device.

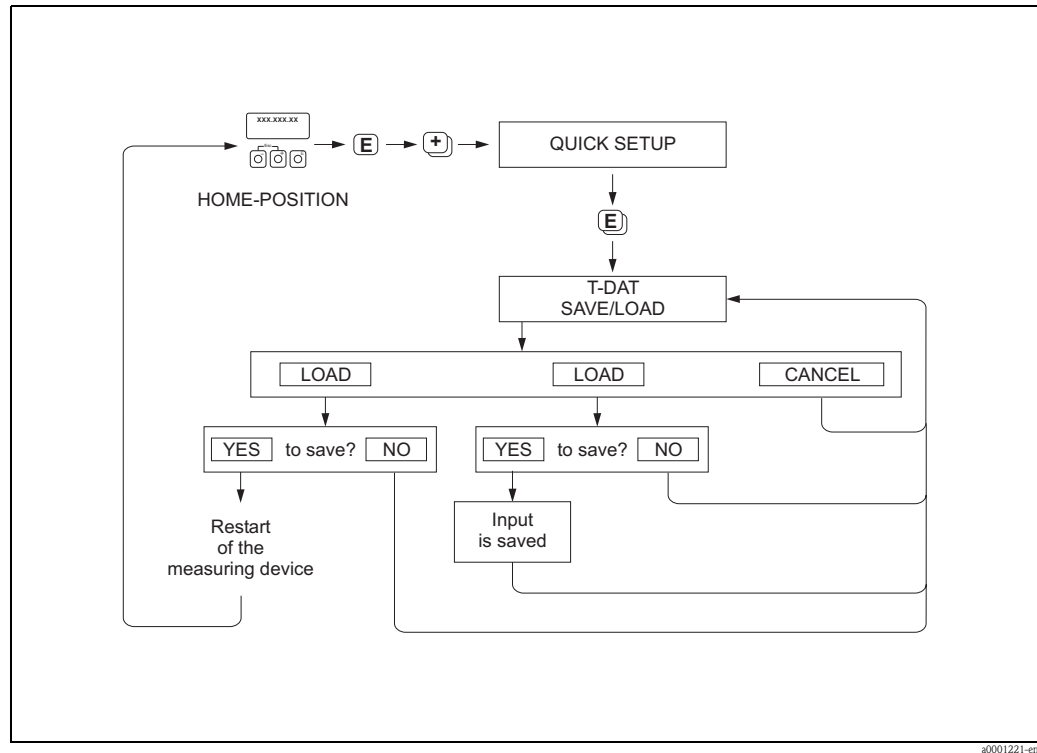

Fig. 33: Data back-up with "T-DAT SAVE/LOAD" function

#### Options

##### LOAD

Data on the T-DAT data storage device are copied to the device memory (EEPROM). This overwrites any settings and parameters of the device. The measuring device is restarted.

##### SAVE

Settings and parameters are copied from the device memory (EEPROM) to the T-DAT.

##### CANCEL

Cancels the option selection and returns you to the higher selection level.

#### Application examples

- After commissioning, the current measuring point parameters can be saved to the T-DAT as a backup.
- If the transmitter is replaced for some reason, the data from the T-DAT can be loaded into the new transmitter -(EEPROM).



#### Note!

- If the target device has an older software version, the message "TRANSM. SW-DAT" is displayed during start-up. Then only the "SAVE" function is available.
- **LOAD**  
This function is only possible if the target device has the same software version as, or a more recent software version than, the source device.
- **SAVE**  
This function is always available.

## 6.4 Configuration



**Warning!**

In the case of explosion-protected equipment, observe a cooling or discharge time of 10 minutes before opening the device.

### 6.4.1 Current output: active/passive

The current outputs are configured as “active” or “passive” by means of various jumpers on the I/O board or the current submodule.



**Warning!**

Risk of electric shock. Exposed components carry dangerous voltages. Make sure that the power supply is switched off before you remove the cover of the electronics compartment.

1. Switch off power supply
2. Remove the I/O board → Page 83 ff.
3. Set the jumpers → Fig. 34



**Caution!**

Risk of destroying the measuring device. Set the jumpers exactly as shown in the diagram. Incorrectly set jumpers can cause overcurrents that would destroy either the measuring device or external devices connected to it.

4. Installation of the I/O board is the reverse of the removal procedure.

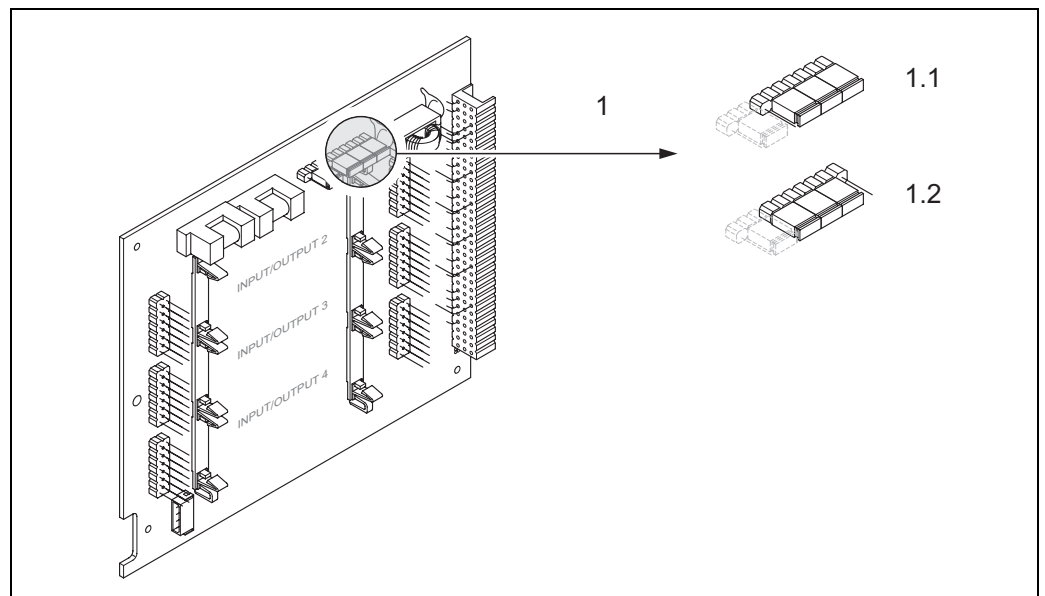

Fig. 34: Configuring current outputs with the aid of jumpers (I/O board)

- 1 Current output 1 with HART
- 1.1 Active current output (default)
- 1.2 Passive current output

## 6.4.2 Pulse/frequency outputs 1 and 2

The configuration of the pulse/frequency output with line monitoring “On” or “Off” takes place by means of various jumpers on the pulse/frequency output submodule.



**Warning!**

Risk of electric shock. Exposed components carry dangerous voltages. Make sure that the power supply is switched off before you remove the cover of the electronics compartment.

1. Switch off power supply
2. Remove the I/O board → → Page 84 ff.
3. Set the jumpers Fig. 35



**Caution!**

– Risk of destroying the measuring device. Set the jumpers exactly as shown in the diagram. Incorrectly set jumpers can cause overcurrents that would destroy either the measuring device or external devices connected to it.

4. Installation of the I/O board is the reverse of the removal procedure.

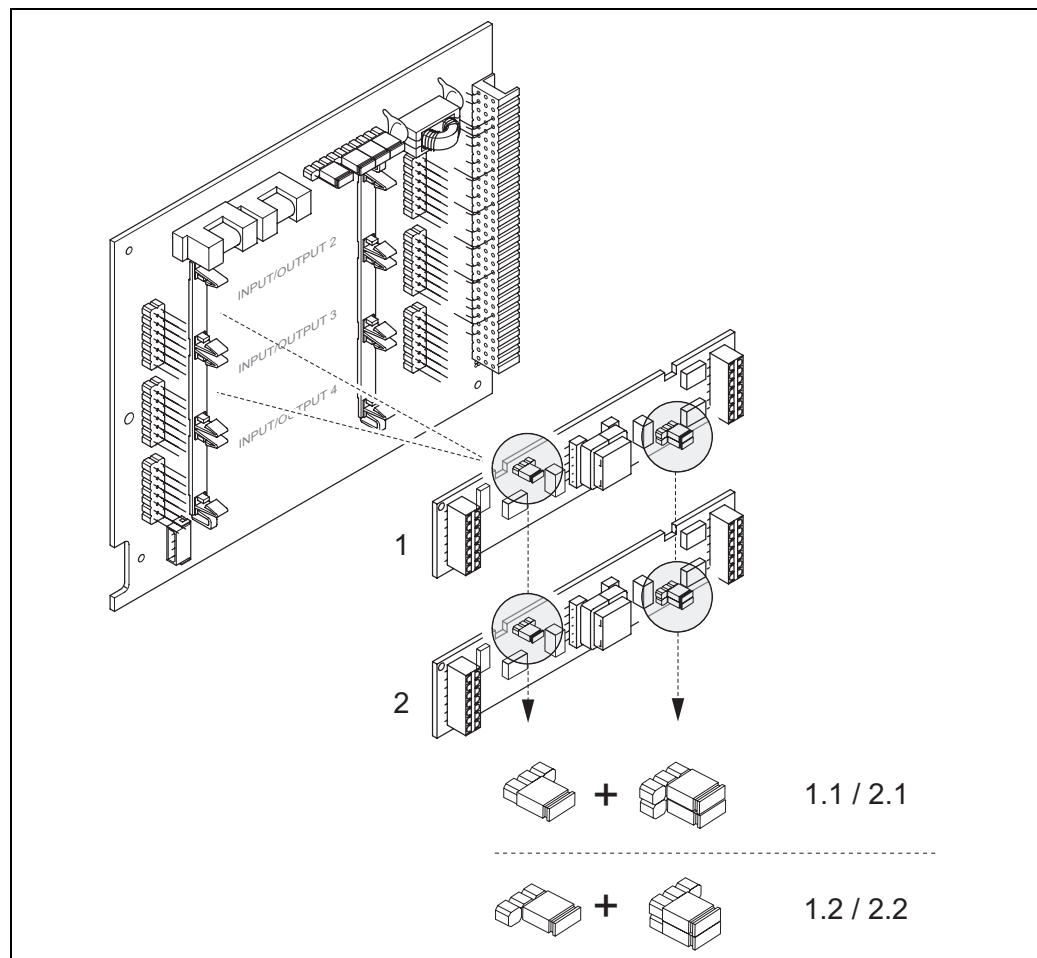

Fig. 35: Configuring pulse/frequency outputs with the aid of jumpers (I/O board)

- 1 Pulse/frequency output 1
  - 1.1 Line monitoring ON (factory setting)
  - 1.2 Line monitoring OFF
- 2 Pulse/frequency output 2
  - 2.1 Line monitoring ON (factory setting)
  - 2.2 Line monitoring OFF

## 6.5 Adjustment

### 6.5.1 Zero point adjustment

All Promass measuring devices are calibrated with state-of-the-art technology. The zero point obtained in this way is printed on the nameplate. Calibration takes place under reference operating conditions. → Page 95

Consequently, the zero point adjustment is generally **not** necessary for Promass!

Experience shows that the zero point adjustment is advisable only in special cases:

- To achieve highest measuring accuracy also with very small flow rates.
- Under extreme process or operating conditions (e.g. very high process temperatures or very high viscosity fluids).

#### Preconditions for a zero point adjustment

Note the following before you perform a zero point adjustment:

- A zero point adjustment can be performed only with fluids that contain no gas or solid contents.
- Zero point adjustment is performed with the measuring tubes completely filled and at zero flow ( $v = 0$  m/s). This can be achieved, for example, with shut-off valves upstream and/or downstream of the sensor or by using existing valves and gates.
  - Normal operation \* valves 1 and 2 open
  - Zero point adjustment *with* pump pressure → Valve 1 open / valve 2 closed
  - Zero point adjustment *without* pump pressure → Valve 1 closed / valve 2 open

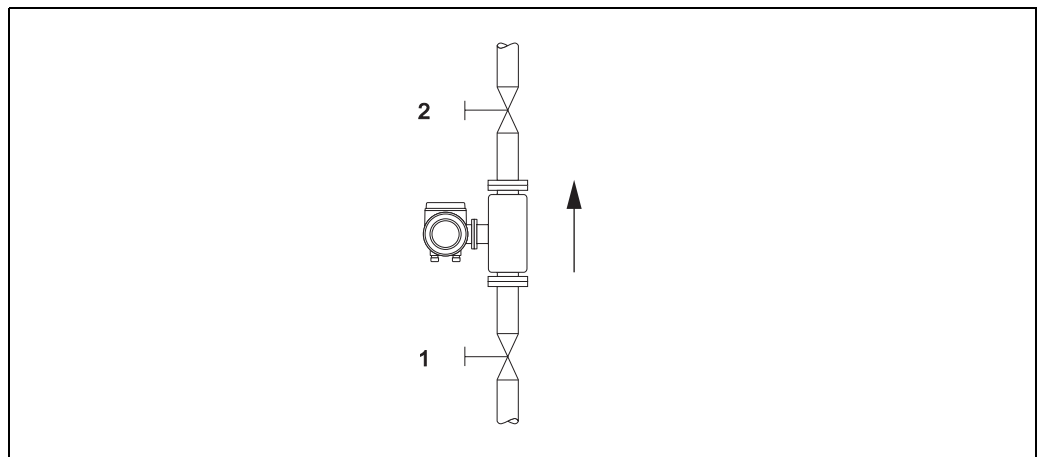

Fig. 36: Zero point adjustment and shut-off valves

F00-xxxxxxx-11-00-00-xx-001



#### Caution!

- If the fluid is very difficult to measure (e.g. containing entrained solids or gas) it may prove impossible to obtain a stable zero point despite repeated zero point adjustments. In instances of this nature, please contact your E+H service center.
- You can view the currently valid zero point value using the “ZERO POINT” function (see the “Description of Device Functions” manual).

### Performing a zero point adjustment

1. Operate the system until operating conditions have settled.
2. Stop the flow ( $v = 0$  m/s).
3. Check the shut-off valves for leaks.
4. Check that operating pressure is correct.
5. Using the local display, select the ZEROPOINT ADJUSTMENT function in the function matrix: BASIC FUNCTIONS → PROCESS PARAMETER → ADJUSTMENT → ZERO POINT ADJUSTMENT
6. When you press  $\left[ \right]$  or  $\left[ \right]$  you are automatically prompted to enter the access code if the function matrix is still disabled. Enter the code (factory setting = 84).
7. Using  $\left[ \right]$  or  $\left[ \right]$ , select the setting START and confirm with  $\left[ \right]$ . Click YES to acknowledge the security prompt and confirm again with  $\left[ \right]$ . Zero point adjustment is now started.
  - The message “ZEROPOINT ADJUST RUNNING” appears on the display for 30...60 seconds while adjustment is in progress.
  - If the flow in the pipe exceeds 0.1 m/s, the following error message appears on the display: "ZERO ADJUST NOT POSSIBLE".
  - When the zero point adjustment completes, the “ZERO ADJUST.” function reappears on the display.
8. Back to the HOME position:
  - Press and hold down Esc key ( $\left[ \right]$ ) for longer than three seconds or
  - Repeatedly press and release the Esc key ( $\left[ \right]$ ).

### 6.5.2 Density adjustment

It is advisable to perform a density adjustment when optimum measuring accuracy is required for calculating density dependent values. The application may require a 1-point or 2-point density adjustment.

#### *1-point density adjustment (with one fluid):*

This type of density adjustment is necessary under the following circumstances:

- The sensor does not measure exactly the density value that the user expects on the basis of laboratory analyses.
- The fluid properties are outside the measuring points set at the factory, or the reference operating conditions used to calibrate the measuring device.
- The system is used exclusively to measure a fluid's density which must be registered to a high degree of accuracy under constant conditions.

Example: Brix density measurement for apple juice.

#### *2-point density adjustment (with two fluids):*

This type of adjustment is always to be carried out if the measuring tubes have been mechanically altered by, e.g. material build-up, abrasion or corrosion. In such cases, the resonant frequency of the measuring tubes has been affected by these factors and is no longer compatible with the calibration data set at the factory. The 2-point density adjustment takes these mechanically-based changes into account and calculates new, adjusted calibration data.

### Performing a 1-point or 2-point density adjustment













Caution!

- On-site density adjustment can be performed only if the user has detailed knowledge of the fluid density, obtained for example from detailed laboratory analyses.
- The target density value specified in this way must not deviate from the measured fluid density by more than  $\pm 10\%$ .
- An error in defining the target density affects all calculated density and volume functions.
- The 2-point density adjustment is only possible if both target density values are different from each other by at least 0.2 kg/l. Otherwise the message "DENSITY ADJUST. ERROR" appears on the display.







- Density adjustment changes the factory density calibration values or the calibration values set by the service technician.
  - The functions outlined in the following instructions are described in detail in the “Description of Device Functions” manual.
1. Fill the sensor with fluid. Make sure that the measuring tubes are completely filled and that liquids are free of gas bubbles.
  2. Wait until the temperature difference between fluid and measuring tube has equalised. The time you have to wait for equalisation depends on the fluid and the temperature level.
  3. Using the local display, select the SETPOINT DENSITY function in the function matrix and perform density adjustment as follows:



Function No.	Function name	Setting to be selected (  or  ) (to next function with  )
6482	DENSITY ADJUST MODE	Use  to select a 1- or 2-point adjustment.   Note! When you press  you are automatically prompted to enter the access code if the function matrix is still disabled. Enter the code.
6483	DENSITY SET VALUE 1	Use  to enter the target density of the first fluid and press  to save this value (input range = actual density value ±10%).
6484	MEASURE FLUID 1	Use  to select START and press  . The message “DENSITY MEASUREMENT RUNNING” appears on the display for approximately 10 seconds. During this time Promass measures the current density of the first fluid (measured density value).





For 2-point density adjustment only:

6485	DENSITY SET VALUE 2	Use  to enter the target density of the second fluid and press  to save this value (input range = actual density value ±10%).
6486	MEASURE FLUID 2	Use  to select START and press  . The message “DENSITY MEASUREMENT RUNNING” appears on the display for approximately 10 seconds. During this time Promass measures the current density of the second fluid (measured density value).



6487	DENSITY ADJUSTMENT	Use  to select DENSITY ADJUSTMENT and press  . Promass compares the measured density value and the target density value and calculates the new density coefficient.
6488	RESTORE ORIGINAL	If the density adjustment does not complete correctly, you can select the RESTORE ORIGINAL function to reactivate the default density coefficient.



Back to the HOME position: → Press and hold down Esc key (  ) for longer than three seconds or → Repeatedly press and release Esc key (  ) → Exit the function matrix step by step		
--	--	--

## 6.6 Purge and pressure monitoring connections

The sensor housing protects the inner electronics and mechanics and is filled with dry nitrogen. Beyond that, up to a specified measuring pressure it additionally serves as secondary containment.



Warning!

For a process pressure above the specified containment pressure, the housing does not serve as an additional secondary containment. In case a danger of measuring tube failure exists due to process characteristics, e.g. with corrosive process fluids, we recommend the use of sensors whose housing is equipped with special pressure monitoring connections (ordering option). With the help of these connections, fluid collected in the housing in the event of tube failure can be drained off. This diminishes the danger of mechanical overload of the housing, which could lead to a housing failure and accordingly is connected with an increased danger potential. These connections can also be used for gas purging (gas detection).

The following instructions apply to handling sensors with purge or pressure monitoring connections:

- Do not open the purge connections unless the containment can be filled immediately with a dry inert gas.
- Use only low gauge pressure to purge. Maximum pressure 5 bar.

## 6.7 Memory (HistoROM)

At Endress+Hauser, the term HistoROM refers to various types of data storage modules on which process and measuring device data are stored. By plugging and unplugging such modules, device configurations can be duplicated onto other measuring devices to cite just one example.

### 6.7.1 HistoROM/S-DAT (sensor-DAT)

The S-DAT is an exchangeable data storage device in which all sensor relevant parameters are stored, i.e., diameter, serial number, calibration factor, zero point.

### 6.7.2 HistoROM/T-DAT (transmitter-DAT)

The T-DAT is an exchangeable data storage device in which all transmitter parameters and settings are stored.

Storing of specific parameter settings from the EEPROM to the T-DAT and vice versa has to be carried out by the user (= manual save function). Detailed instructions regarding this can be found in the handbook "Description of Device Functions" (function "T-DAT SAVE/LOAD", No. 1009).

## 7 Custody transfer measurement

Promass 84 is a flowmeter suitable for custody transfer measurement for liquids (other than water) and for gases under high pressure (> 100 bar).

### 7.1 Suitability for custody transfer measurement, approval by the Standards Authorities, repeated calibration due to legal metrology controls

- All Promass 84 flowmeters are verified on site using reference measurements. Only once it has been approved by the authority for legal metrology controls may the measuring device be regarded as verified and used for applications subject to legal metrology controls. The associated seal on the measuring device ensures this status.



Caution!

Only flowmeters verified by the Standards Authorities may be used for invoicing in applications subject to legal metrology controls.

- The owner-operator of a verified Promass 84 measuring system is obliged to carry out repeat calibration on the unit in accordance with the regulations of the authority for legal metrology controls.
- In contrast to mechanical counters, mass flowmeters which have been verified by the Standards Authorities may be operated continuously at  $Q_{100\%} = Q_{\max}$  in accordance with the approval certificate.

#### 7.1.1 Approval for custody transfer

The following guidelines for the custody transfer process were developed in accordance with the following authorities for legal metrology controls:

- **PTB**, Germany
- **NMi**, The Netherlands
- **METAS**, Switzerland
- **BEV**, Austria

#### 7.1.2 Special features of working in the custody transfer mode

- In the custody transfer mode, the flow may only be measured and totalized in one direction of flow (forward). For this reason, make sure that the “MEASURING MODE” function has been set to “FORWARD” for the totalizer and to “STANDARD” for the outputs.
- In the custody transfer mode, error messages that occur during operation must be confirmed and reset. The error messages can also be reset by means of the status input.

#### Switching on the power supply in custody transfer mode

If the device is started in custody transfer mode, for example also after a power outage, system error No. 271 “POWER BRK. DOWN” flashes on the local display. The fault message can be acknowledged or reset using the “Enter” key or by means of the status input configured accordingly.

## 7.2 Definition of terms

### Terms used in the subject area “suitability for custody transfer measurement for liquids other than water”

<ul style="list-style-type: none"> <li>■ Additional devices</li> </ul>	Equipment that does not have a direct effect on the measurement but which is needed to ensure correct measuring or make it easier (e.g. gas display units, filters, pumps, etc.)
<ul style="list-style-type: none"> <li>■ Adjust</li> </ul>	Adjustment on site (zero point, density) under operating conditions. Is performed by the facility's owner-operator.
<ul style="list-style-type: none"> <li>■ Ancillary equipment</li> </ul>	Equipment used for direct further processing of the measurement result (e.g. printers, quantity convertors, price calculators, pre-set devices, etc.)
<ul style="list-style-type: none"> <li>■ Calibrate</li> </ul>	Determine and save correction values for the individual measuring instrument to get as close as possible to the "real" value with the measured value.
<ul style="list-style-type: none"> <li>■ Counter</li> </ul>	Device for measuring, saving and displaying the variables subject to mandatory verification (mass, volume, density, etc.)
<ul style="list-style-type: none"> <li>■ Maintenance</li> </ul>	Upon request, the authority responsible can give companies that repair verified measuring devices (repairers) the authority to mark repaired devices (repairer mark) if they have the equipment necessary for repair and adjustment and have properly trained specialist staff. Endress+Hauser is authorised to carry out repair work on verified measuring devices.
<ul style="list-style-type: none"> <li>■ Measured error</li> </ul>	(Also known as limit of permissible error, error limit or inaccuracy). Relative measurement error, derived from the quotient (measured value – “true” measured value) / “true” measured value in per cent.
<ul style="list-style-type: none"> <li>■ Measuring system</li> </ul>	Measuring device that includes the counter and all the ancillary equipment and additional devices.
<ul style="list-style-type: none"> <li>■ <math>Q_{\min}</math></li> </ul>	Minimum flow as of which the counter must observe the error limits.
<ul style="list-style-type: none"> <li>■ <math>Q_{\max}</math></li> </ul>	Maximum flow of the counter while observing the error limits.
<ul style="list-style-type: none"> <li>■ Quantity convertor</li> </ul>	Unit for automatically converting the measured value determined to another variable (pressure, temperature, density, etc.) or non-volatile saved conversion values for the fluid.
<ul style="list-style-type: none"> <li>■ Stamp points</li> </ul>	To be provided on all parts of the measuring system which cannot otherwise be protected against any alteration (falsification) to measured value determination and processing. Lead stamping is preferably used but adhesive seals are also permitted. They may only be affixed by an authorised party, namely authority for legal metrology controls or service team with field service mark.
<ul style="list-style-type: none"> <li>■ Suitable for custody transfer measurement</li> </ul>	A measuring system or a part of the system, for example counters or accessory equipment, has the (type) “approval for national verification” of a (national) approval centre.
<ul style="list-style-type: none"> <li>■ Verified</li> </ul>	The measuring system has been inspected and sealed on site by a representative of the authority for legal metrology controls. This must be arranged by the facility's owner-operator.
<ul style="list-style-type: none"> <li>■ Verify</li> </ul>	Inspection of a measuring system to determine the measured error from the "true" value with subsequent system sealing. Verification can only be carried out on site by the authority for legal metrology controls responsible.

## 7.3 Verification process

Type-approved measuring systems for liquids other than water are always verified at their place of deployment. For this purpose, the facility's owner-operator must make everything available when the Standards Authorities come to inspect and approve the system. This includes:

- Scales or container with a reading unit with a load or volumetric capacity that corresponds to the operation of the system at  $Q_{\max}$  for one minute. The resolution of the scales display or the reading unit must be at least 0.1 % of the minimum measured quantity.
- Unit for removing the medium being measured after the totalizer to fill the scales or the container.
- Making a sufficient quantity of the medium being measured available. The quantity is derived from the operation of the system. The following rule of thumb applies - quantity at:
  - 3 x 1 minute at  $Q_{\min}$ ,
  - plus 3 x 1 minute at  $\frac{1}{2} Q_{\max}$ ,
  - plus 3 x 1 minute at  $Q_{\max}$ ,
  - plus adequate quantity in reserve.

### 3-stage process of approval by the Standards Authority

1. Properties inspection:  
The measuring system is inspected as to whether all the parts relevant to verification meet the general regulations (Verification Ordinance) and, in particular, the regulations for approval of the individual parts (counters, ancillary equipment, etc.). The data on the nameplate(s) are also checked.
2. Measuring inspection:  
In general, the system is examined with three measured values ( $Q_{\min}$ ,  $\frac{1}{2} Q_{\max}$ , and  $Q_{\max}$ ). All the results may not exceed the specified maximum measured error (e.g.  $\pm 0.5\%$ ).
3. Official stamp:  
The measuring system is sealed at the specified points (seal diagram) by the representative of the authority for legal metrology controls responsible.

### 7.3.1 Setting up custody transfer mode

The device has to be operational and not set to custody transfer mode.

1. Configure the functions important for custody transfer measurement, such as the output configuration, custody transfer variable and the measuring mode.  
In the "CUSTODY TRANSFER" block (function block Z; functions 2001...2008), the outputs relevant for custody transfer measurement can be set to custody transfer and the current custody transfer status can be displayed.  
In the "OUTPUTS" block (function block E), the custody transfer variables can be assigned to the existing outputs.  
In the "INPUTS" block (function block F), a switching behaviour is assigned to the input.

 Note!

Please refer to the separate Device Functions manual for a detailed description of the functions.

2. Once all the functions relevant to custody transfer have been configured, the custody transfer code is entered in the "ACCESS CODE (2020)" cell.

#### **Custody transfer code: 8400**

The functions are locked once you enter the custody transfer code. These functions are marked with a keyhole symbol in the separate Device Functions manual ().

3. Seal the device.  
(See next graphic)
4. The device is suitable for custody transfer measurement. The flow measurement may now be used in applications subject to legal metrology controls.

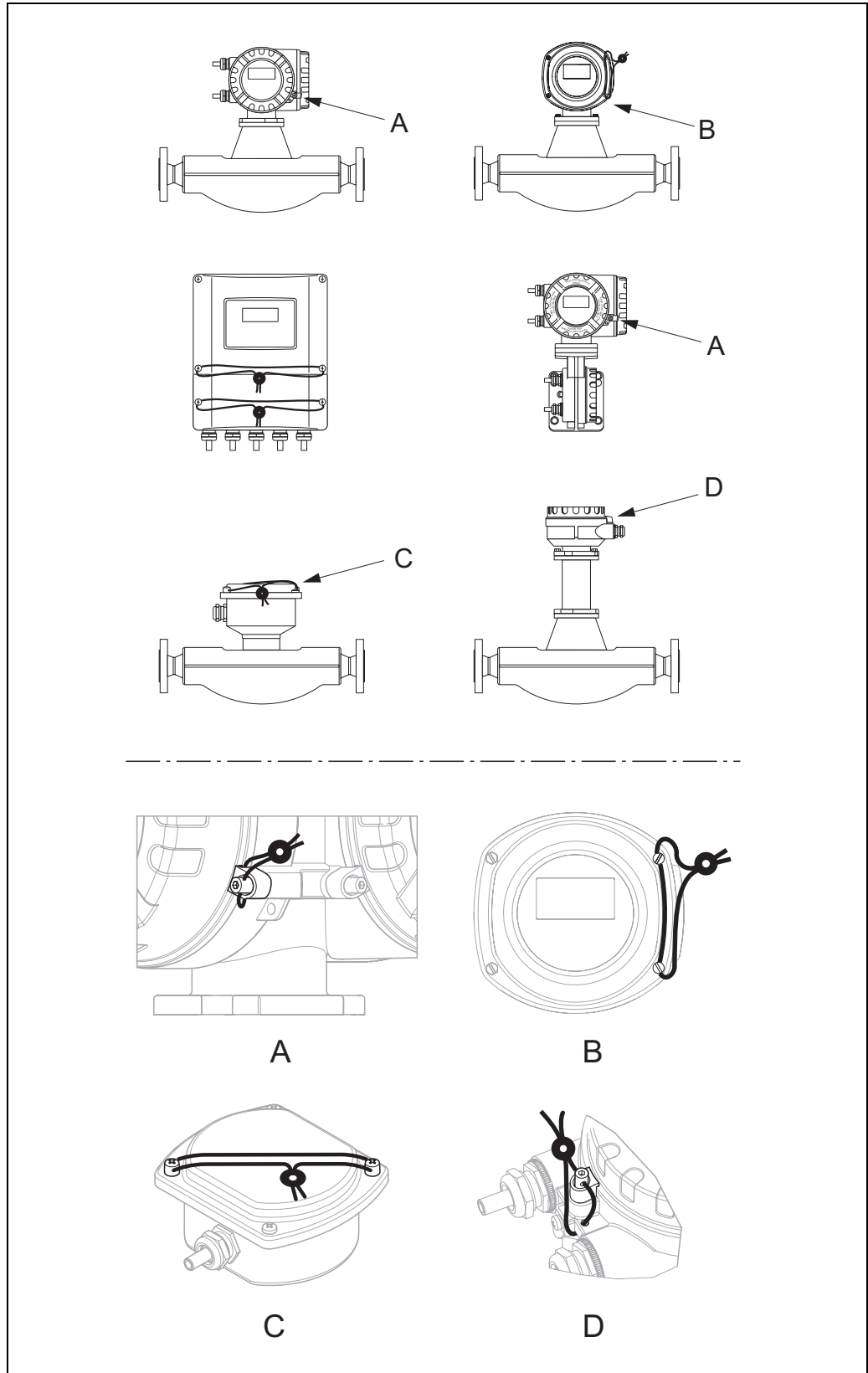

Fig. 37: Examples of how to seal the various device versions.

a0001778

### 7.3.2 Disabling custody transfer mode

The device has to be operational and already set to custody transfer mode.

1. Disconnect the device from the operating voltage.
2. Remove the custody transfer seals.



Warning!

In the case of explosion-protected equipment, observe a cooling or discharge time of 10 minutes before opening the device.

3. Open the cover of the transmitter housing electronics compartment.  
Detailed procedure for the compact version → Page 84  
Detailed procedure for the wall-mount housing → Page 86
4. Remove the S-DAT
5. Reconnect the device to the power supply.
6. The device runs through the start-up cycle.  
After start-up, the error message “#031 SENSOR HW-DAT” is displayed.



Note!

This error message appears because the S-DAT has been removed.  
This does not have any effect on the subsequent steps.

7. Disconnect the device from the power supply again.
8. Reinsert the S-DAT.
9. Screw the covers of the electronics compartment and the display module back on.
10. Reconnect the device to the power supply.
11. The device runs through the start-up cycle.  
During start-up, the message “CUSTODY TRANSFER NO” appears on the display.
12. The device is now operational and is not in custody transfer mode.
- 13.



Note!

To set the device back to custody transfer mode, proceed as described on Page 69.

## 8 Maintenance

No special maintenance work is required.

### 8.1 External cleaning

When cleaning the exterior of measuring devices, always use cleaning agents that do not attack the surface of the housing and the seals.

### 8.2 Replacing seals

Under normal circumstances, fluid wetted seals of the Promass A and Promass M sensors do not require replacement. Replacement is necessary only in special circumstances, for example if aggressive or corrosive fluids are incompatible with the seal material.



Note!

- The period between changes depends on the fluid properties and on the frequency of cleaning cycles in the case of CIP/SIP cleaning
- Replacement seals (accessories)



## 9 Accessories

Various accessories, which can be ordered separately from Endress+Hauser, are available for the transmitter and the sensor. Detailed information on the order code in question can be obtained from the Endress+Hauser service organisation.

### 9.1 Device-specific accessories

Accessory	Description	Order code
Transmitter Proline Promass 84	Transmitter for replacement or for stock. Use the order code to define the following specifications: <ul style="list-style-type: none"> <li>– Approvals</li> <li>– Degree of protection / version,</li> <li>– Cable entries</li> <li>– Display / power supply / operation</li> <li>– Outputs / inputs.</li> </ul>	84XXX - XXXXX * * * * *

### 9.2 Measuring principle-specific accessories

Accessory	Description	Order code
Mounting set for transmitter	Mounting set for remote version. Suitable for: <ul style="list-style-type: none"> <li>– Wall mounting</li> <li>– Pipe mounting</li> <li>– Installation in control panel</li> </ul> Mounting set for aluminium field housing: Suitable for pipe mounting (3/4"..."3")	DK8WM - *
Post mounting set for the Promass A sensor	Post mounting set for the Promass A	DK8AS - * *
Mounting set for the Promass A sensor	Mounting set for Promass A, comprising: <ul style="list-style-type: none"> <li>– 2 process connections</li> <li>– Seals</li> </ul>	DK8MS - * * * * *
Set of seals for sensor	For regular replacement of the seals of the Promass M and Promass A sensors. Set consists of two seals.	DKS - * * *

### 9.3 Communication-specific accessories

Accessory	Description	Order code
HART Communicator DXR 375 handheld terminal	Handheld terminal for remote parameterisation and for obtaining measured values via the current output HART (4...20 mA). Contact your Endress+Hauser representative for more information.	DXR375 - * * * * *





## 9.4 Service-specific accessories

Accessory	Description	Order code
Applicator	Software for selecting and configuring flowmeters. Applicator can be downloaded from the Internet or ordered on CD-ROM for installation on a local PC. Contact your Endress+Hauser representative for more information.	DKA80 - *
ToF Tool - Fieldtool Package	<p>Modular software package consisting of the service program "ToF Tool" for configuration and diagnosis of ToF level measuring devices (time-of-flight measurement) and the "Fieldtool" service program for the configuration and diagnosis of Proline flowmeters. The Proline flowmeters are accessed via a service interface or via the service interface FXA 193.</p> <p>Contents of the "ToF Tool - Fieldtool Package":</p> <ul style="list-style-type: none"> <li>- Commissioning, maintenance analysis</li> <li>- Configuring flowmeters</li> <li>- Service functions</li> <li>- Visualisation of process data</li> <li>- Trouble-shooting</li> <li>- Controlling the "Fieldcheck" tester/simulator"</li> </ul> <p>Contact your Endress+Hauser representative for more information.</p>	DXS10 - * * * * *

# 10 Trouble-shooting

## 10.1 Trouble-shooting instructions

Always start trouble-shooting with the following checklist if faults occur after commissioning or during operation. The routine takes you directly to the cause of the problem and the appropriate remedial measures.

Check the display	
No display visible and no output signals present.	<ol style="list-style-type: none"> <li>1. Check the supply voltage → Terminals 1, 2</li> <li>2. Check device fuse → Page 88 85...260 V AC: 0.8 A slow-blow / 250 V 20...55 V AC and 16...62 V DC: 2 A slow-blow / 250 V</li> <li>3. Measuring electronics defective → order spare parts → Page 83</li> </ol>
No display visible, but output signals are present.	<ol style="list-style-type: none"> <li>1. Check whether the ribbon-cable connector of the display module is correctly plugged into the amplifier board → Page 83 ff.</li> <li>2. Display module defective → order spare parts → Page 83</li> <li>3. Measuring electronics defective → order spare parts → Page 83</li> </ol>
Display texts are in a foreign language.	Switch off power supply. Press and hold down both the  keys and switch on the measuring device. The display text will appear in English (default) and is displayed at maximum contrast.
Measured value indicated, but no signal at the current or pulse output	Measuring electronics defective → order spare parts → Page 83
▼	
Error messages on display	
<p>Errors that occur during commissioning or measuring are displayed immediately. Error messages consist of a variety of icons. The meanings of these icons are as follows (example):</p> <ul style="list-style-type: none"> <li>– Type of error: <b>S</b> = System error, <b>P</b> = Process error</li> <li>– Error message type:  = Fault message,  = Notice message</li> <li>– <b>FLUID INHOM.</b> = error designation (e.g. fluid is not homogeneous)</li> <li>– <b>03:00:05</b> = Duration of error occurrence (in hours, minutes and seconds)</li> <li>– <b>#702</b> = Error number</li> </ul> <p> <b>Caution!</b></p> <ul style="list-style-type: none"> <li>■ See the information on → Page 36</li> <li>■ The measuring system interprets simulations and positive zero return as system errors, but displays them as notice message only.</li> </ul>	
Error number: No. 001 - 399 No. 501 - 699	System error (device error) has occurred → Page 76
Error number: No. 400 - 499 No. 700 - 799	Process error (application error) has occurred → Page 80
▼	
Other error (without error message)	
Some other error has occurred.	Diagnosis and rectification → Seite 81

## 10.2 System error messages

Serious system errors are **always** recognised by the instrument as “Fault message”, and are shown as a lightning flash (⚡) on the display! Fault messages immediately affect the inputs and outputs. Simulations and positive zero return, on the other hand, are classed and displayed as “Notice messages”.



Caution!

In the event of a serious fault, a flowmeter might have to be returned to the manufacturer for repair. Important procedures must be carried out before you return a flowmeter to Endress+Hauser.  
→ Page 8

Always enclose a duly completed "Declaration of contamination" form. You will find a preprinted blank of this form at the back of this manual.



Note!

- The listed error message types below correspond to the factory setting.
- Also observe the information on the following pages: → Page 36

No.	Error message / Type	Cause	Remedy / spare part
S = System error ⚡ = Fault message (with an effect on the inputs and outputs) ! = Notice message (without any effect on the inputs and outputs)			
<b>No. # 0xx * Hardware error</b>			
<b>001</b>	S: CRITICAL FAILURE ⚡: # 001	Serious device error	Replace the amplifier board. Spare part → Page 83
<b>011</b>	S: AMP HW EEPROM ⚡: # 011	Amplifier: Defective EEPROM	Replace the amplifier board. Spare parts → Page 83
<b>012</b>	S: AMP SW EEPROM ⚡: # 012	Measuring amplifier: Error when accessing data of the EEPROM	The EEPROM data blocks in which an error has occurred are displayed in the “TROUBLE-SHOOTING” function. Press Enter to acknowledge the errors in question; default values are automatically inserted instead of the errored parameter values. Note! The measuring device has to be restarted if an error has occurred in a totalizer block (see also error no. 111 / CHECKSUM TOTAL.).
<b>031</b>	S: SENSOR HW DAT ⚡: # 031	Sensor DAT: 1. SS-DAT is defective 2. -DAT is not plugged into the amplifier board or is missing.	1. Replace the S-DAT. Spare parts → Page 83 Check the spare part set number to ensure that the new, replacement DAT is compatible with the measuring electronics. 2. Plug the S-DAT into the amplifier board → Page 84 → Page 86
<b>032</b>	S: SENSOR SW DAT ⚡: # 032	Sensor DAT: Error accessing the calibration values stored in the S-DAT.	1. Check whether the S-DAT is correctly plugged into the amplifier board → Page 84 → Page 86 2. Replace the S-DAT if it is defective. Spare parts → Page 83 Before replacing the DAT, check that the new, replacement DAT is compatible with the measuring electronics. Check the: – Spare part set number – Hardware revision code 3. Replace measuring electronics boards if necessary. Spare parts → Page 83
<b>041</b>	S: TRANSM. HW DAT ⚡: # 041	Sensor DAT: 1. T-DAT is defective 2. T-DAT is not plugged into the amplifier board or is missing.	1. Replace the T-DAT. Spare parts → Page 83 Check the spare part set number to ensure that the new, replacement DAT is compatible with the measuring electronics. 2. Plug the T-DAT into the amplifier board → Page 84 → Page 86

No.	Error message / Type	Cause	Remedy / spare part
042	S: TRANSM. SW DAT !/: # 042	Sensor DAT: Error accessing the calibration values stored in the S-DAT.	<ol style="list-style-type: none"> <li>1. Check whether the T-DAT is correctly plugged into the amplifier board → Page 84 → Page 86</li> <li>2. Replace the T-DAT if it is defective. Spare parts → Page 83 Before replacing the DAT, check that the new, replacement DAT is compatible with the measuring electronics. Check the: <ul style="list-style-type: none"> <li>– Spare part set number</li> <li>– Hardware revision code</li> </ul> </li> <li>3. Replace measuring electronics boards if necessary. Spare parts → Page 83</li> </ol>
051	S: A / C COMPATIB. !/: # 051	The I/O board and the amplifier board are not compatible.	<p>Use only compatible modules and boards. Check the compatibility of the modules used.</p> <p>Check the:</p> <ul style="list-style-type: none"> <li>– Spare part set number</li> <li>– Hardware revision code</li> </ul>
<b>No. # 1xx * Software error</b>			
111	S: CHECKSUM TOTAL. !/: # 111	Totalizer checksum error	<ol style="list-style-type: none"> <li>1. Restart the measuring device</li> <li>2. Replace the amplifier board if necessary. Spare parts → Page 83</li> </ol>
121	S: A / C COMPATIB. !/: # 121	<p>Due to different software versions, I/O board and amplifier board are only partially compatible (possibly restricted functionality).</p> <p> <b>Note!</b></p> <ul style="list-style-type: none"> <li>– This message is only listed in the error history.</li> <li>– Nothing is displayed on the display.</li> </ul>	<p>Module with lower software version has either to be actualized by ToF Tool - Fieldtool Package with the required software version or the module has to be replaced. Spare parts → Page 83</p>
<b>No. # 2xx * Error in DAT / no communication</b>			
205	S: LOAD T-DAT !/: # 205	Transmitter DAT: Data backup (downloading) to T-DAT failed, or error when accessing (uploading) the calibration values stored in the T-DAT.	<ol style="list-style-type: none"> <li>1. Check whether the T-DAT is correctly plugged into the amplifier board → Page 84→ Page 86</li> <li>2. Replace the T-DAT if it is defective. Spare parts → Page 83 Before replacing the DAT, check that the new, replacement DAT is compatible with the measuring electronics. Check the: <ul style="list-style-type: none"> <li>– Spare part set number</li> <li>– Hardware revision code</li> </ul> </li> <li>3. Replace measuring electronics boards if necessary. Spare parts → Page 83</li> </ol>
206	S: SAVE T-DAT !/: # 206		
251	S: COMMUNICATION I/O !/: # 251	Internal communication fault on the amplifier board.	Remove the amplifier board. Spare parts → Page 83
261	S: COMMUNICATION I/O !/: # 261	No data reception between amplifier and I/O board or faulty internal data transfer.	Check the BUS contacts
271	S: POWER BRK. DOWN !/: # 271	Power supply interrupted. Error message appears during device start-up in custody transfer mode after a power failure.	Confirm with the ENTER key or reset via the auxiliary input.
<b>No. # 3xx → System limits exceeded</b>			
339 ... 342	S: STACK CUR OUT n !/: # 339...342	The temporarily buffered flow portions (measuring mode for pulsating flow) could not be cleared or output within 60 seconds.	<ol style="list-style-type: none"> <li>1. Change the upper or lower limit setting, as applicable</li> <li>2. Increase or reduce flow, as applicable</li> </ol> <p>Recommendations in the event of fault category = FAULT MESSAGE (!/):</p> <ul style="list-style-type: none"> <li>– Configure the fault response of the output to “ACTUAL VALUE”, so that the temporary buffer can be cleared. → Page 83</li> <li>– Clear the temporary buffer by the measures described under Item 1.</li> </ul>
343 ... 346	S: STACK FREQ. OUT n !/: # 343...346		

No.	Error message / Type	Cause	Remedy / spare part
347 ... 350	S: STACK PULSE OUT n !: # 347...350	The temporarily buffered flow portions (measuring mode for pulsating flow) could not be cleared or output within 60 seconds.	<ol style="list-style-type: none"> <li>Increase the setting for pulse weighting</li> <li>Increase the max. pulse frequency if the totalizer can handle a higher number of pulses.</li> <li>Increase or reduce flow, as applicable.</li> </ol> Recommendations in the event of fault category = FAULT MESSAGE (!): <ul style="list-style-type: none"> <li>Configure the fault response of the output to "ACTUAL VALUE", so that the temporary buffer can be cleared. → Page 83</li> <li>Clear the temporary buffer by the measures described under Item 1.</li> </ul>
351 ... 354	S: CURRENT RANGE n !: # 351...354	Current output: The actual value for the flow lies outside the set limits.	<ol style="list-style-type: none"> <li>Change the upper or lower limit setting, as applicable.</li> <li>Increase or reduce flow, as applicable.</li> </ol>
355 ... 358	S: FREQ. RANGE n !: # 355...358	Frequency output: The actual value for the flow lies outside the set limits.	<ol style="list-style-type: none"> <li>Change the upper or lower limit setting, as applicable.</li> <li>Increase or reduce flow, as applicable.</li> </ol>
359 ... 362	S: PULSE RANGE !: # 359...362	Pulse output: Pulse output frequency is out of range.	<ol style="list-style-type: none"> <li>Increase the setting for pulse weighting</li> <li>When selecting the pulse width, choose a value that can still be processed by a connected counter (e.g. mechanical counter, PLC etc.). <i>Determine the pulse width:</i> <ul style="list-style-type: none"> <li>Variant 1: Enter the minimum duration that a pulse must be present at the connected counter to ensure its registration.</li> <li>Variant 2: Enter the maximum (pulse) frequency as the half "reciprocal value" that a pulse must be present at the connected counter to ensure its registration.</li> </ul>                     Example: The maximum input frequency of the connected counter is 10 Hz. The pulse width to be entered is:                     <math display="block">\frac{1}{2 \cdot 10\text{Hz}} = 50\text{ms}</math> </li> <li>Reduce flow</li> </ol>
379 ... 380	S: FREQ. LIM !: # 379...380	The measuring tube oscillation frequency is outside the permitted range.  Causes: <ul style="list-style-type: none"> <li>Change the upper or lower limit setting, as applicable.</li> <li>Increase or reduce flow, as applicable.</li> </ul>	Contact your E+H service organisation.
381	S: FLUIDTEMP.MIN. !: # 381	The temperature sensor on the measuring tube is likely defective.	Check the following electrical connections before you contact your E+H service organisation: <ul style="list-style-type: none"> <li>Verify that the sensor signal cable connector is correctly plugged into the amplifier board. → Page 84 → Page 86</li> <li>Remote version: Check sensor and transmitter terminal connections No. 9 and 10. → Page 24</li> </ul>
382	S: FLUIDTEMP.MAX. !: # 382		
383	S: CARR.TEMP.MIN !: # 383	The temperature sensor on the carrier tube is likely defective.	Check the following electrical connections before you contact your E+H service organisation: <ul style="list-style-type: none"> <li>Verify that the sensor signal cable connector is correctly plugged into the amplifier board → Page 84 → Page 86</li> <li>Remote version: Check sensor and transmitter terminal connections No. 11 and 12. → Page 24</li> </ul>
384	S: CARR.TEMP.MAX !: # 384		

No.	Error message / Type	Cause	Remedy / spare part
385	S: INL.SENS.DEF. !: # 385	One of the measuring tube exciter coils (inlet) is likely defective.	Check the following electrical connections before you contact your E+H service organisation: – Verify that the sensor signal cable connector is correctly plugged into the amplifier board. → Page 84 → Page 86 – Remote version: Check sensor and transmitter terminal connections No. 4, 5, 6 and 7. → Page 24
386	S: OUTL.SENS.DEF. !: # 386	One of the measuring tube exciter coils (outlet) is likely defective.	
387	S: SEN.ASY.EXCEED !: # 387	Measuring pipe excitation coil is probably faulty.	
388 ... 390	S: AMP. FAULT !: # 388...390	Amplifier error	
<b>No. # 5xx</b> → Application error			
501	S: SW.-UPDATE ACT. !: # 501	New amplifier or communication (I/O module) software version is loaded. Currently no other functions are possible.	Wait until process is finished. The device will restart automatically.
502	S: UP-/DOWNLOAD ACT. !: # 502	Up- or downloading the device data via configuration program. Currently no other functions are possible.	Wait until process is finished.
586	S: OSC. AMP. LIMIT !: # 586	The fluid properties do not allow a continuation of the measurement.  Causes: – Extremely high viscosity – Process fluid is very inhomogeneous (gas or solid content)	Change or improve process conditions.
587	S: TUBE OSC. NOT !: # 587	Extreme process conditions exist. The measuring system can therefore not be started.	Change or improve process conditions.
588	S: GAIN RED.IMPOS !: # 588	Overdriving of the internal analog to digital converter.  Causes: – Cavitation – Extreme pressure pulses – High gas flow velocity  A continuation of the measurement is no longer possible!	Change or improve process conditions, e.g. by reducing the flow velocity.
<b>No. # 6xx</b> → Simulation mode active			
601	S: POSITIVE ZERO RETURN !: # 601	Positive zero return active.  Caution! This message has the highest display priority.	Switch off positive zero return
611 ... 614	S: SIM. CURR. OUT n !: # 611...614	Simulation current output active	
621 ... 624	S: SIM. FREQ. OUT n !: # 621...624	Simulation frequency output active	Switch off simulation
631 ... 634	S: SIM. PULSE n !: # 631...634	Simulation pulse output active	Switch off simulation
671 ... 674	S: SIM. STAT. IN n !: # 671...674	Simulation status input active	Switch off simulation
691	S: SIM. FAILSAFE !: # 691	Simulation of response to error (outputs) active	Switch off simulation
692	S: SIM. MEASURAND !: # 692	Simulation of measuring variables (e.g. mass flow)	Switch off simulation
698	S: DEV. TEST AKT. !: # 698	The measuring device is being checked on site via the test and simulation device.	–

### 10.3 Process error messages

Process errors can be defined as either “Fault” or “Notice” messages and can thereby be weighted differently. This is specified via the function matrix (→ “Description of Device Functions” manual).



Note!

- The listed error message types below correspond to the factory setting.
- Also observe the information on the following pages: → Page 36

No.	Error message / Type	Cause	Remedy / spare part
P = Process error ⚡ = Fault message (with an effect on the inputs and outputs) ! = Notice message (without any effect on the inputs and outputs)			
700	P: EMPTY PIPE ⚡: # 700	The process fluid density is outside the upper or lower limit values set in the “EPD” function  Causes: – Air in the measuring tube – Partly filled measuring tube	1. Ensure that there is no gas content in the process liquid. 2. Adapt the values in the “EPD” function to the current process conditions.
701	P: EXC. CURR. LIM ⚡: # 701	The maximum current value for the measuring tube exciter coils has been reached, since certain process fluid characteristics are extreme, e.g. high gas or solid content. The instrument continues to work correctly.	In particular with outgassing fluids and/or increased gas content, the following measures are recommended to increase system pressure:  1. Install the instrument at the outlet side of a pump. 2. Install the instrument at the lowest point of an ascending pipeline. 3. Install a flow restriction, e.g. reducer or orifice plate, downstream from the instrument.
702	P: FLUID INHOM. ⚡: # 702	Frequency control is not stable, due to inhomogeneous process fluid, e.g. gas or solid content.	
703	P: NOISE LIM. CH0 ⚡: # 703	Overdriving of the internal analog to digital converter.  Causes: – Cavitation – Extreme pressure pulses – High gas flow velocity  A continuation of the measurement is still possible!	Change or improve process conditions, e.g. by reducing the flow velocity.
704	P: NOISE LIM. CH1 ⚡: # 704		
705	P: FLOW LIMIT ⚡: # 705	The mass flow is too high. The electronics' measuring range will be exceeded.	Reduce flow
731	P: ADJ. ZERO FAIL !: # 731	The zero point adjustment is not possible or has been cancelled.	Make sure that zero point adjustment is carried out at “zero flow” only (v = 0 m/s). → Page 63



## 10.4 Process errors without messages

Symptoms	Rectification
<p>Comment: You may have to change or correct certain settings of the function matrix in order to rectify faults. The functions outlined below, such as DISPLAY DAMPING, for example, are described in detail in the "Description of Device Functions" manual.</p>	
Measured value reading fluctuates even though flow is steady.	<ol style="list-style-type: none"> <li>1. Check the fluid for presence of gas bubbles.</li> <li>2. "TIME CONSTANT" function * increase value (* OUTPUTS / CURRENT OUTPUT / CONFIGURATION)</li> <li>3. "DISPLAY DAMPING" function * increase value (* USER INTERFACE / CONTROL / BASIC CONFIGURATION)</li> </ol>
Flow values are negative, even though the fluid is flowing forwards through the pipe.	Change the "INSTALLATION DIRECTION SENSOR" function accordingly
Measured-value reading or measured-value output pulsates or fluctuates, e.g. because of reciprocating pump, peristaltic pump, diaphragm pump or pump with similar delivery characteristic.	<p>Run the "Pulsating Flow" Quick Setup. → Page 55 If the problem persists despite these measures, a pulsation damper will have to be installed between pump and measuring device.</p>
There are differences between the flowmeter's internal totalizer and the external metering device.	<p>This symptom is due primarily to backflow in the piping, because the pulse output cannot subtract in the "STANDARD" or "SYMMETRY" measuring modes.</p> <p>The problem can be solved as follows: Allow for flow in both directions. Set the "MEASURING MODE" function to "Pulsating Flow" for the pulse output in question.</p>
Measured value reading shown on display, even though the fluid is at a standstill and the measuring tube is full.	<ol style="list-style-type: none"> <li>1. Check the fluid for presence of gas bubbles.</li> <li>2. Activate the "ON-VAL. LF-CUTOFF" function, i.e. enter or increase the value for the low flow cut off (→ BASIC FUNCTION / PROCESSPARAMETER / CONFIGURATION).</li> </ol>

## 10.5 Response of outputs to errors



Note!

The failsafe mode of totalizers, current, pulse and frequency outputs can be customised by means of various functions in the function matrix. You will find detailed information on these procedures in the “Description of Device Functions” manual.

You can use positive zero return to set the signals of the current, pulse and status outputs to their fallback value, for example when measuring has to be interrupted while a pipe is being cleaned. This function takes priority over all other device functions. Simulations, for example, are suppressed.

Failsafe mode of outputs and totalizers		
	Process/system error is present	Positive zero return is activated
<b>Caution!</b> System or process errors defined as “Notice messages” have no effect whatsoever on the inputs and outputs. See the information on → Page 36 ff.		
Current output	<b>MIN. CURRENT</b> The current output will be set to the lower value of the signal on alarm level depending on the setting selected in the CURRENT SPAN (see the “Description of Device Functions” manual). <b>MAX. CURRENT</b> The current output will be set to the higher value of the signal on alarm level depending on the setting selected in the CURRENT SPAN (see the “Description of Device Functions” manual). <b>HOLD VALUE</b> Measured value display on the basis of the last saved value preceding occurrence of the fault. <b>ACTUAL VALUE</b> Measured value display on the basis of the current flow measurement. The fault is ignored.	Output signal corresponds to “zero flow”
Pulse output	<b>FALLBACK VALUE</b> Signal output → no pulses <b>HOLD VALUE</b> Last valid value (preceding occurrence of the fault) is output. <b>ACTUAL VALUE</b> Fault is ignored, i.e. normal measured value output on the basis of ongoing flow measurement.	Output signal corresponds to “zero flow”
Frequency output	<b>FALLBACK VALUE</b> Signal output → 0 Hz <b>FAILSAFE VALUE</b> Output of the frequency specified in the FAILSAFE VALUE function. <b>HOLD VALUE</b> Last valid value (preceding occurrence of the fault) is output. <b>ACTUAL VALUE</b> Fault is ignored, i.e. normal measured value output on the basis of ongoing flow measurement.	Output signal corresponds to “zero flow”
Totalizer	<b>STOP</b> The totalizers are paused until the error is rectified. <b>ACTUAL VALUE</b> The fault is ignored. The totalizer continues to count in accordance with the current flow value. <b>HOLD VALUE</b> The totalizers continue to count the flow in accordance with the last valid flow value (before the error occurred).	Totalizer stops

## 10.6 Spare parts

The previous sections contain a detailed trouble-shooting guide. → Page 75 ff.

The measuring device, moreover, provides additional support in the form of continuous self-diagnosis and error messages.

Fault rectification can entail replacing defective components with tested spare parts. The illustration below shows the available scope of spare parts.



Note!

You can order spare parts directly from your E+H service organisation by providing the serial number printed on the transmitter's nameplate → Seite 9.

Spare parts are shipped as sets comprising the following parts:

- Spare part
- Additional parts, small items (threaded fasteners, etc.)
- Mounting instructions
- Packaging

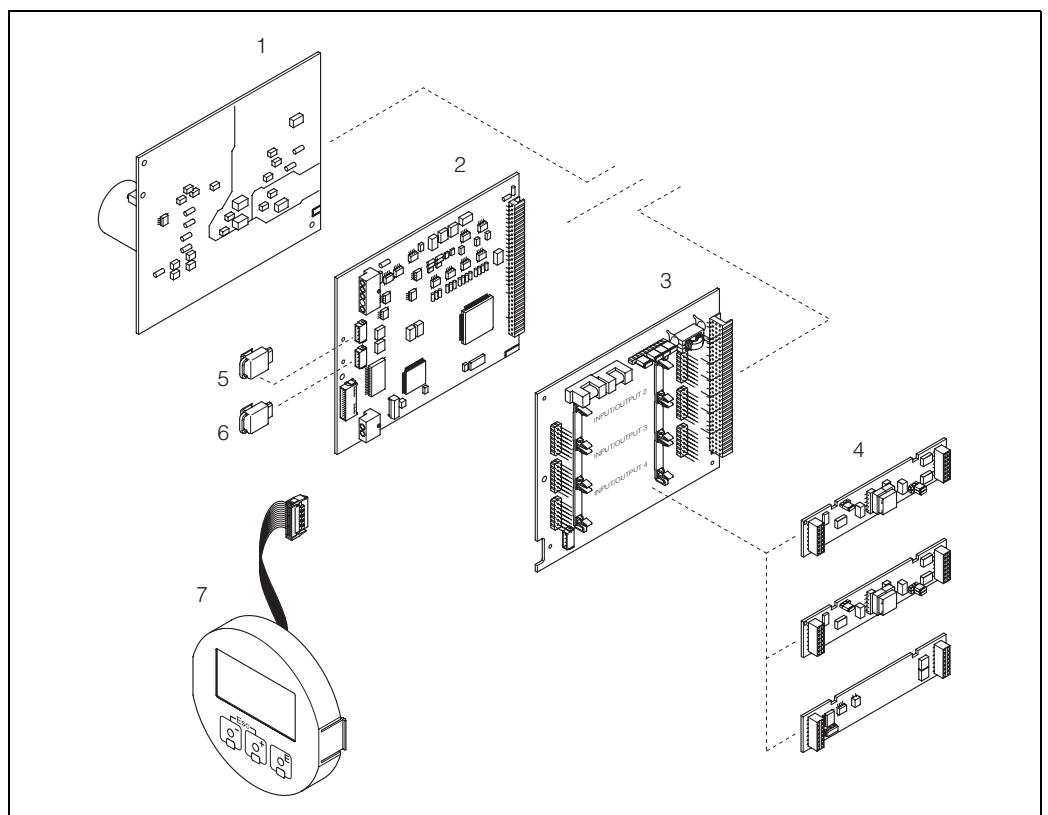

Fig. 38: Spare parts for transmitter 84 (field and wall-mount housings)

- 1 Power unit board (85...260 V AC, 20...55 V AC, 16...62 V DC)
- 2 Amplifier board
- 3 I/O board (COM module), flexible assignment
- 4 → Page 73 ff. Pluggable input/output submodules; ordering structure
- 5 S-DAT (sensor data memory)
- 6 T-DAT (transmitter data memory)
- 7 Display module

## 10.6.1 Removing and installing printed circuit boards

### Field housing



#### Warning!

- Risk of electric shock. Exposed components carry dangerous voltages. Make sure that the power supply is switched off before you remove the cover of the electronics compartment.
- In the case of explosion-protected equipment, observe a cooling or discharge time of 10 minutes before opening the device.
- Risk of damaging electronic components (ESD protection). Static electricity can damage electronic components or impair their operability. Use a workplace with a grounded working surface purposely built for electrostatically sensitive devices!
- If you cannot guarantee that the dielectric strength of the device is maintained in the following steps, then an appropriate inspection must be carried out in accordance with the manufacturer's specifications.
- When connecting Ex-certified devices, see the notes and diagrams in the Ex-specific supplement to these Operating Instructions.



#### Caution!

Use only original Endress+Hauser parts.

Fig. 39, installation and removal:

1. Unscrew cover of the electronics compartment from the transmitter housing.
  2. Remove the local display (1) as follows:
    - Press in the latches (1.1) at the side and remove the display module.
    - Disconnect the ribbon cable (1.2) of the display module from the amplifier board.
  3. Remove the screws and remove the cover (2) from the electronics compartment.
  4. Remove power unit board (4) and I/O board (6, 7):
    - Insert a thin pin into the hole (3) provided for the purpose and pull the board clear of its holder.
  5. Remove submodules (6.1):
    - No tools are required for removing the submodules (inputs/outputs) from the I/O board. Installation is also a no-tools operation.
-  **Caution!**  
 Only certain combinations of submodules on the I/O board are permissible. → Seite 27  
 The individual slots are marked and correspond to certain terminals in the connection compartment of the transmitter:
- Slot "INPUT / OUTPUT 2" = Terminals 24 / 25
  - Slot "INPUT / OUTPUT 3" = Terminals 22 / 23
  - Slot "INPUT / OUTPUT 4" = Terminals 20 / 21
6. Remove amplifier board (5):
    - Disconnect the plug of the sensor signal cable (5.1) including S-DAT (5.3) from the board.
    - Gently disconnect the plug of the excitation current cable (5.2) from the board, i.e. without moving it back and forward.
    - Insert a thin pin into the hole (3) provided for the purpose and pull the board clear of its holder.
  7. Installation is the reverse of the removal procedure.

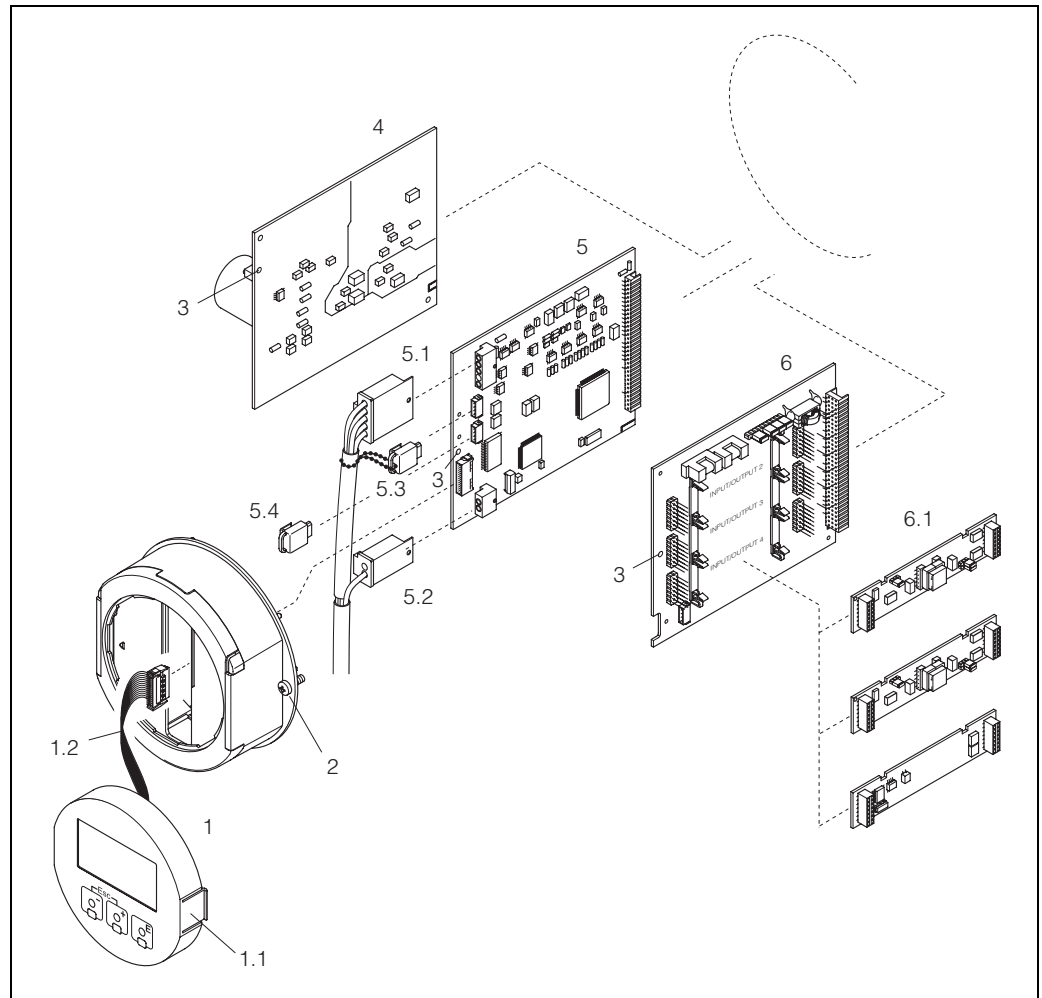

a0001744

Fig. 39: Field housing: removing and installing printed circuit boards

- 1 Local display
- 1.1 Latch
- 1.2 Ribbon cable (display module)
- 2 Screws of electronics compartment cover
- 3 Aperture for installing/removing boards
- 4 Power unit board
- 5 Amplifier board
- 5.1 Signal cable (sensor)
- 5.2 Excitation current cable (sensor)
- 5.3 S-DAT (sensor data memory)
- 5.4 T-DAT (transmitter data memory)
- 6 I/O board (flexible assignment)
- 6.1 Pluggable submodules (current output, pulse/frequency output, status input)

**Wall-mount housing****Warning!**

- Risk of electric shock. Exposed components carry dangerous voltages. Make sure that the power supply is switched off before you remove the cover of the electronics compartment.
- In the case of explosion-protected equipment, observe a cooling or discharge time of 10 minutes before opening the device.
- Risk of damaging electronic components (ESD protection). Static electricity can damage electronic components or impair their operability. Use a workplace with a grounded working surface purposely built for electrostatically sensitive devices!
- If you cannot guarantee that the dielectric strength of the device is maintained in the following steps, then an appropriate inspection must be carried out in accordance with the manufacturer's specifications.
- When connecting Ex-certified devices, see the notes and diagrams in the Ex-specific supplement to these Operating Instructions.

**Caution!**

Use only original Endress+Hauser parts.

Fig. 40, installation and removal:

1. Remove the screws and open the hinged cover (1) of the housing.
2. Remove the screws securing the electronics module (2). Then push up electronics module and pull it as far as possible out of the wall-mount housing.
3. Disconnect the following cable plugs from amplifier board (7):
  - Sensor signal cable plug (7.1) including S-DAT (7.3)
  - Unplug excitation current cable (7.2). Gently disconnect the plug, i.e. without moving it back and forward.
  - Ribbon cable plug (3) of the display module.
4. Remove the cover (4) from the electronics compartment by loosening the screws.
5. Remove the boards (6, 7, 8, 9):  
Insert a thin pin into the hole (5) provided for the purpose and pull the board clear of its holder.
6. Remove submodules (8.1):  
No tools are required for removing the submodules (inputs/outputs) from the I/O board. Installation is also a no-tools operation.

**Caution!**

Only certain combinations of submodules on the I/O board are permissible. → Seite 27

The individual slots are marked and correspond to certain terminals in the connection compartment of the transmitter:

Slot "INPUT / OUTPUT 2" = Terminals 24 / 25

Slot "INPUT / OUTPUT 3" = Terminals 22 / 23

Slot "INPUT / OUTPUT 4" = Terminals 20 / 21

7. Installation is the reverse of the removal procedure.

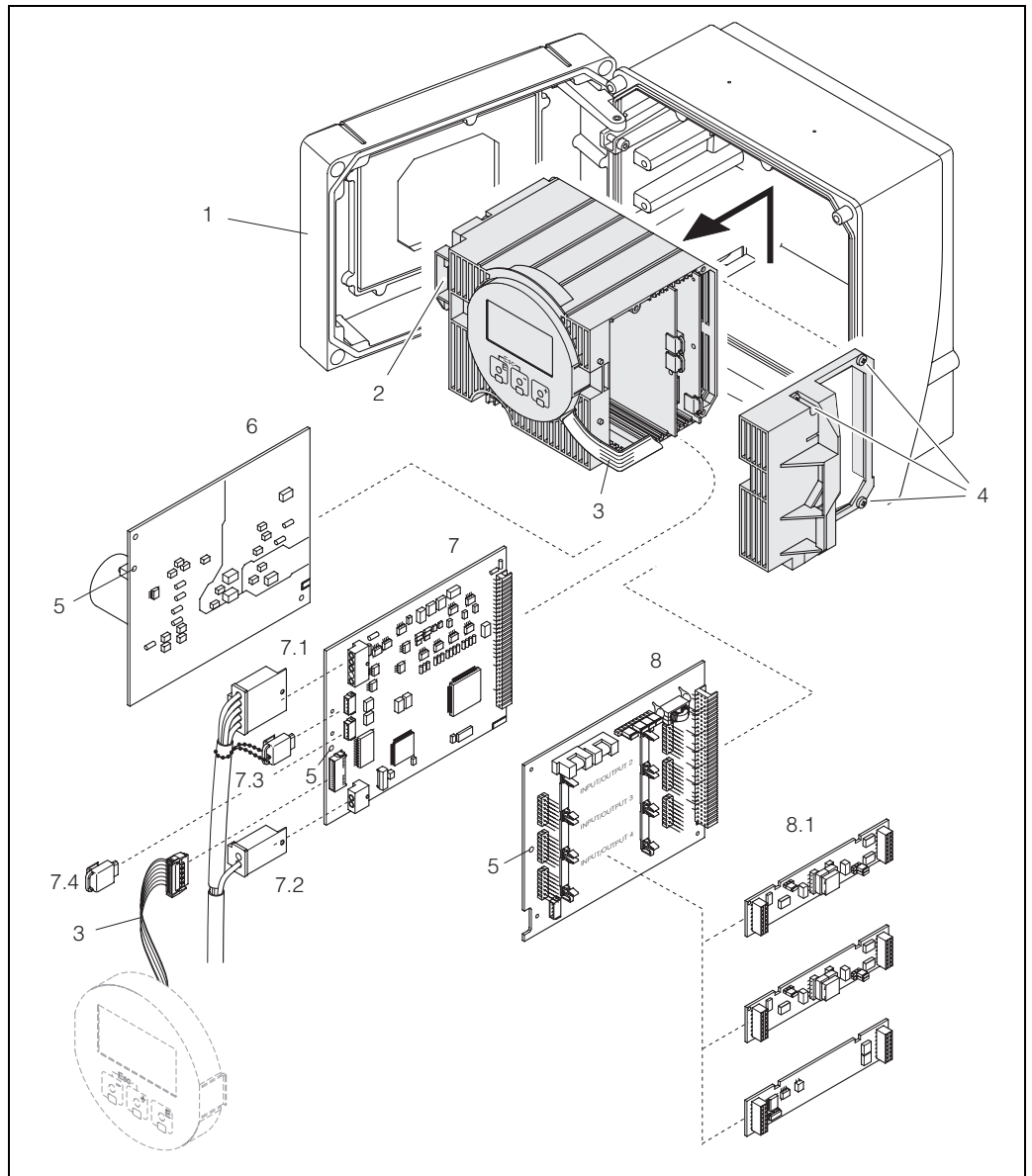

Fig. 40: Wall-mount housing: removing and installing printed circuit boards

- 1 Housing cover
- 2 Electronics module
- 3 Ribbon cable (display module)
- 4 Screws of electronics compartment cover
- 5 Aperture for installing/removing boards
- 6 Power unit board
- 7 Amplifier board
- 7.1 Signal cable (sensor)
- 7.2 Excitation current cable (sensor)
- 7.3 S-DAT (sensor data memory)
- 7.4 T-DAT (transmitter data memory)
- 8 I/O board (flexible assignment)
- 8.1 Pluggable submodules (current output, pulse/frequency output, status input)

### 10.6.2 Replacing the device fuse



Warning!

- Risk of electric shock. Exposed components carry dangerous voltages. Make sure that the power supply is switched off before you remove the cover of the electronics compartment.
- In the case of explosion-protected equipment, observe a cooling or discharge time of 10 minutes before opening the device.

The main fuse is on the power unit board.

The procedure for replacing the fuse is as follows:

1. Switch off power supply.
2. Remove the power unit board, → Page 84 → Page 86
3. Remove the protection cap (1) and replace the device fuse (2). Only use the following fuse type:  
Now remove the following cable connectors from the amplifier board (7):
  - 20...55 V AC / 16...62 V DC → 2.0 A slow-blow / 250 V; 5.2 x 20 mm
  - Power supply 85...260 V AC → 0.8 A slow-blow / 250 V; 5.2 x 20 mm
  - Ex-rated devices \* see the Ex documentation
4. Installation is the reverse of the removal procedure.



Caution!

Use only original Endress+Hauser parts.

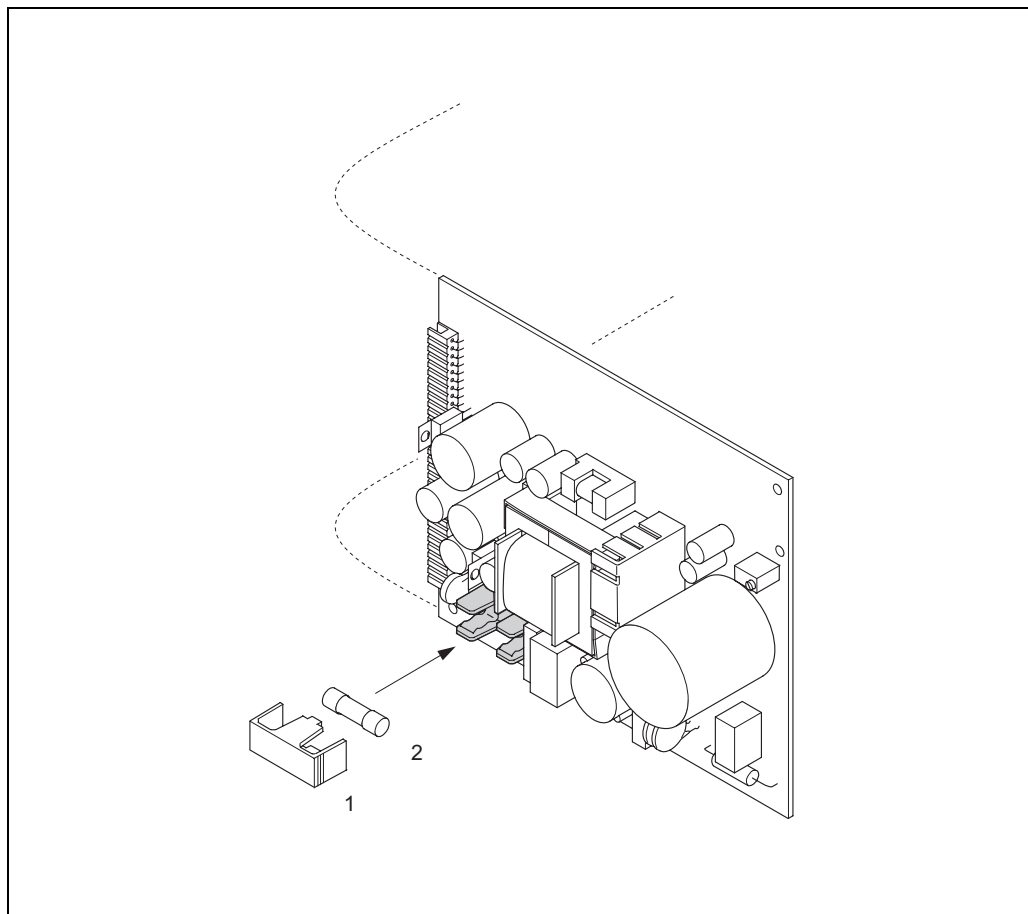

Fig. 41: Replacing the device fuse on the power unit board

- 1 Protective cap
- 2 Device fuse



## 10.7 Return

The following procedures must be carried out before a flowmeter requiring repair or calibration, for example, is returned to Endress+Hauser:

- Always enclose a duly completed “Declaration of contamination” form. Only then can Endress+Hauser transport, examine and repair a returned device.
- Enclose special handling instructions if necessary, for example a safety data sheet as per EN 91/155/EEC.
- Remove all residues. Pay special attention to the grooves for seals and crevices which could contain residues. This is particularly important if the substance is hazardous to health, e.g. flammable, toxic, caustic, carcinogenic, etc.  
With Promass A and Promass M the threaded process connections must first be removed from the sensor and then cleaned.



Note!

You will find a preprinted “Declaration of contamination” form at the back of this manual.



Warning!

- Do not return a measuring device if you are not absolutely certain that all traces of hazardous substances have been removed, e.g. substances which have penetrated crevices or diffused through plastic.
- Costs incurred for waste disposal and injury (burns, etc.) due to inadequate cleaning will be charged to the owner-operator.

## 10.8 Disposal

Observe the regulations applicable in your country!

## 10.9 Software history



Note!

Up or downloading a software version normally requires a special service software.

Date	Software version	Changes to software	Operating Instructions
11.2004	2.00.XX	Original software  Compatible with: - Fieldtool - HART Communicator DXR 375 Rev. 06, DD 1	50108928/03.05

## 11 Technical data

### 11.1 Technical data at a glance

#### 11.1.1 Applications

The measuring device described in these Operating Instructions is to be used only for measuring the mass flow rate of liquids and gases. At the same time, the system also measures fluid density and fluid temperature. These parameters are then used to calculate other variables such as volume flow. Fluids with widely differing properties can be measured.

Examples:

- Chocolate, condensed milk, liquid sugar
- Oils, fats
- Acids, alkalis, lacquers, paints, solvents and cleaning agents
- Pharmaceuticals, catalysts, inhibitors
- Suspensions
- Gases, liquefied gases, etc.

Resulting from incorrect use or from use other than that designated the operational safety of the measuring devices can be suspended. The manufacturer accepts no liability for damages being produced from this.

#### 11.1.2 Function and system design

---

Measuring principle

Mass flow measurement by the Coriolis principle

---

Measuring system

The “Promass 84” flow measuring system consists of the following components:

- Promass 84 transmitter
- Promass F, Promass M, Promass A sensors

Two versions are available:

- Compact version: transmitter and sensor form a single.
- Remote version: transmitter and sensor are installed separately.

#### 11.1.3 Input

---

Measured variable

- Mass flow (proportional to the phase difference between two sensors mounted on the measuring tube to register a phase shift in the oscillation)
- Fluid density (proportional to resonance frequency of the measuring tube)
- Fluid temperature (via temperature sensors)/(not suitable for custody transfer measurement)

Measuring range in non-custody transfer mode

*Measuring ranges for liquids (Promass F, M):*

DN	Range for full scale values (liquids) $\dot{m}_{\min(F)} \dots \dot{m}_{\max(F)}$
8	0...2000 kg/h
15	0...6500 kg/h
25	0...18000 kg/h
40	0...45000 kg/h
50	0...70000 kg/h
80	0...180000 kg/h
100 (only Promass F)	0...350000 kg/h
150 (only Promass F)	0...800000 kg/h
250 (only Promass F)	0...2200000 kg/h

*Measuring ranges for liquids (Promass A):*

DN	Range for full scale values (liquids) $\dot{m}_{\min(F)} \dots \dot{m}_{\max(F)}$
2	0...100 kg/h
4	0...450 kg/h

*Measuring ranges for gases*

The full scale values depend on the density of the gas. Use the formula below to calculate the full scale values:

$$\dot{m}_{\max(G)} = \dot{m}_{\max(F)} \cdot \rho_{(G)} / x \text{ [kg/m}^3\text{]}$$

$$\dot{m}_{\max(G)} = \text{Max. full scale value for gas [kg/h]}$$

$$\dot{m}_{\max(F)} = \text{Max. full scale value for liquid [kg/h]}$$

$$\rho_{(G)} = \text{Gas density in [kg/m}^3\text{] for process conditions}$$

$$x = 160 \text{ (Promass F DN 8...100, M); } x = 250 \text{ (Promass F DN 150...250);}$$

$$x = 32 \text{ (Promass A)}$$

Here,  $\dot{m}_{\max(G)}$  can never be greater than  $\dot{m}_{\max(F)}$

*Calculation example for gas:*

- Sensor type: Promass F, DN 50
- Gas: air with a density of 60.3 kg/m<sup>3</sup> (at 20 °C and 50 bar)
- Measuring range: 70000 kg/h
- x = 160 (for Promass F DN 50)

Max. possible full scale value:

$$\dot{m}_{\max(G)} = \dot{m}_{\max(F)} \cdot \rho_{(G)} / x \text{ [kg/m}^3\text{]} = 70000 \text{ kg/h} \cdot 60.3 \text{ kg/m}^3 \div 160 \text{ kg/m}^3 = 26400 \text{ kg/h}$$

*Recommended full scale values*

See → Page 100 ff. ("Limiting flow")

Measuring range in custody transfer mode

Measuring ranges for liquids in mass flow (Promass F, M):

DN	Range for mass flow (liquids) (in relation to 1.0 kg/dm <sup>3</sup> ) $Q_{min}$ [kg/min]... $Q_{max}$ [kg/min]	Smallest measured quantity [kg]
8	1.5...30	0.5
15	5...100	2
25	15...300	5
40	35...700	20
50	50...1000	50
80	150...3000	100
100 (only Promass F)	200...4500	200
150 (only Promass F)	350...12000	500
250 (only Promass F)	1500...35000	1000

Measuring ranges for liquids in mass flow (Promass A):

DN	Range for mass flow (liquids) (in relation to 1.0 kg/dm <sup>3</sup> ) $Q_{min}$ [kg/min]... $Q_{max}$ [kg/min]	Smallest measured quantity [kg]
2	0.1...2	0.05
4	0.4...8	0.20

Measuring ranges for high pressure fuel gases CNG (Promass M):

DN	Range for mass flow (liquids) (in relation to 1.0 kg/dm <sup>3</sup> ) $Q_{min}$ [kg/min]... $Q_{max}$ [kg/min]	Smallest measured quantity [kg]	Maximum pressure [bar]
8	0.1...10	0.2	250 / 350*
15	0.3...40	0.5	250 / 350*
25	1.0...100	2.0	250 / 350*
* High pressure version			

Measuring ranges for liquids in volume flow (also LPG) (Promass F, M):

DN	Range for volume flow (liquids) (in relation to 1.0 l/min) $Q_{min}$ [l/min]... $Q_{max}$ [l/min]	Smallest measured quantity [l]
8 (only Promass F)	1.5...30	0.5
15 (only Promass F)	5...100	2
25 (only Promass F)	15...300	5
40 (only Promass F)	35...700	20
50 (only Promass F)	50...1000	50
80	150...3000	100
100 (only Promass F)	200...4500	200
150 (only Promass F)	350...12000	500
250 (only Promass F)	1500...35000	1000

*Measuring ranges for liquids in volume flow (also LPG) (Promass A):*

DN	Range for mass flow (liquids) (in relation to 1.0 kg/dm <sup>3</sup> ) $Q_{\min}$ [l/min]... $Q_{\max}$ [l/min]	Smallest measured quantity [l]
2	0.1...2	0.05
4	0.4...8	0.20

Operable flow range Over 20 : 1 for verified device

Input signal

*Status input (auxiliary input):*

U = 3...30 V DC, R<sub>i</sub> = 5 kΩ, galvanically isolated.

Configurable for: totalizer reset, positive zero return, error message reset, start zero point adjustment

### 11.1.4 Output

Output signal

*Current output:*

Active/passive selectable, galvanically isolated, time constant selectable (0.05...100 s), full scale value selectable, temperature coefficient: typically 0.005% o.r./°C, resolution: 0.5 μA

- Active: 0/4...20 mA, R<sub>L</sub> < 700 Ω (for HART: R<sub>L</sub> ≥ 250 Ω)
- Passive: 4...20 mA; supply voltage V<sub>S</sub> 18...30 V DC; R<sub>i</sub> ≥ 150 Ω

*Pulse / frequency output:*

For custody transfer measurement, two pulse outputs can be operated, phase-shifted 90°.

Passive, galvanically isolated, open collector, 30 V DC, 250 mA

- Frequency output: full scale frequency 2...10000 Hz (f<sub>max</sub> = 12500 Hz), on/off ratio 1:1, pulse width max. 2 s
- Pulse output: pulse value and pulse polarity selectable, pulse width configurable (0.05...2000 ms)

Signal on alarm

*Current output:*

Failsafe mode selectable (for example, according to NAMUR recommendation NE 43)

*Pulse/frequency output:*

Failsafe mode selectable

*Status output:*

De-energised by fault or power supply failure

Load

See "Output signal"

Low flow cut off                      Switch points for low flow cut off are selectable.

Nominal diameter [mm]	Low flow cutoff / factory settings (v ~ 0.04 m/s)	
	SI units [kg/h]	US units [lb/min]
2	0.40	0.015
4	1.80	0.066
8	8.00	0.300
15	26.00	1.000
25	72.00	2.600
40	180.00	6.600
50	300.00	11.000
80	720.00	26.000
100	1200.00	44.000
150	2600.00	95.000
250	7200.00	260.000

Galvanic isolation                      All circuits for inputs, outputs, and power supply are galvanically isolated from each other.

### 11.1.5 Power supply

Electrical connections                      → Page 24 ff.

Supply voltage                      85...260 V AC, 45...65 Hz  
20...55 V AC, 45...65 Hz  
16...62 V DC

Cable entry                      Power supply and signal cables (inputs/outputs):

- Cable entry M20 x 1.5 (8...12 mm)
- Threads for cable entries, 1/2" NPT, G 1/2"

Connecting cable for remote version:

- Cable entry M20 x 1.5 (8...12 mm)
- Threads for cable entries, 1/2" NPT, G 1/2"

Cable specifications, remote version                      see Page 25

Power consumption                      AC: <15 VA (including sensor)  
DC: <15 W (including sensor)

Switch-on current

- max. 13.5 A (< 50 ms) at 24 V DC
- max. 3 A (< 5 ms) at 260 V AC

Power supply failure                      Lasting min. 1 power cycle:

- EEPROM or HistoROM T-DAT saves measuring system data if power supply fails.
- HistoROM/S-DAT: exchangeable data storage chip which stores the data of the sensor (nominal diameter, serial number, calibration factor, zero point, etc.)

Potential equalisation                      No measures necessary.  
For explosion-protected equipment → see separate Ex-documentation supplied

### 11.1.6 Performance characteristics

Reference operating conditions

Error limits following ISO/DIS 11631:

- 20...30 °C; 2...4 bar
- Calibration systems as per national norms
- Zero point calibrated under operating conditions
- Field density calibrated (or special density calibration)

Maximum measured error

The following values refer to the pulse/frequency output. Deviation at the current output is typically  $\pm 5 \mu\text{A}$ .

#### *Mass flow (liquid)*

*Promass F, M, A:*

$\pm 0.10\% \pm [(\text{zero point stability} / \text{measured value}) \times 100]\% \text{ o.r.}$

#### *Mass flow (gas)*

*Promass F:*

$\pm 0.35\% \pm [(\text{zero point stability} / \text{measured value}) \times 100]\% \text{ o.r.}$

*Promass M, A:*

$\pm 0.50\% \pm [(\text{zero point stability} / \text{measured value}) \times 100]\% \text{ o.r.}$

#### *Volume flow (liquid)*

*Promass F:*

$\pm 0.15\% \pm [(\text{zero point stability} / \text{measured value}) \times 100]\% \text{ o.r.}$

*Promass M, A:*

$\pm 0.25\% \pm [(\text{zero point stability} / \text{measured value}) \times 100]\% \text{ o.r.}$

*Zero point stability (Promass A):*

DN	Maximum full scale value [kg/h] or [l/h]	Zero point stability [kg/h] or [l/h]
2	100	0.0050
4	450	0.0225

Zero point stability (Promass F, M):

DN	Max. full scale value [kg/h] or [l/h]	Zero point stability		
		Promass F [kg/h] or [l/h]	Promass F (high-temperature) [kg/h] or [l/h]	Promass M [kg/h] or [l/h]
8	2000	0.060	–	0.100
15	6500	0.200	–	0.325
25	18000	0.540	1.80	0.90
40	45000	2.25	–	2.25
50	70000	3.50	7.00	3.50
80	180000	9.00	18.00	9.00
100	350000	14.00	–	–
150	800000	32.00	–	–
250	2200000	88.00	–	–

Sample calculation

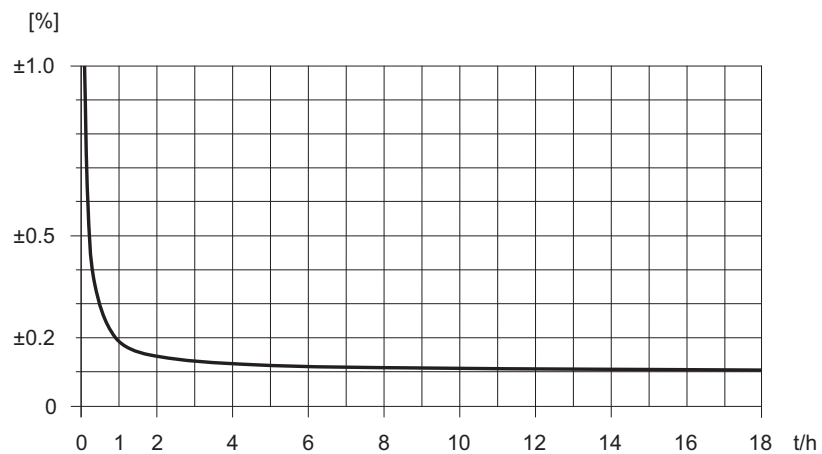

F06-83xxxxxx-05-xx-xx-xx-000

Fig. 42: Maximum measured error in % of reading (example: Promass 83 F / DN 25)

Calculation example (mass flow, liquid):

Given: Promass 83 F / DN 25, flow = 8000 kg/h

Max. measured error:  $\pm 0.10\% \pm [(zero\ point\ stability / measured\ value) \times 100]\%$  o.r.

Maximum measured error  $\rightarrow \pm 0.10\% \pm 0.54\ kg/h \div 8000\ kg/h \cdot 100\% = \pm 0.107\%$



**Density (liquid)***After field density calibration or under reference conditions:**Promass F:* $\pm 0.0005 \text{ g/cc}$ *Promass M, A:* $\pm 0.0010 \text{ g/cc}$ *Special density calibration (optional), not for high-temperature version  
(calibration range = 0.8...1.8 g/cc, 5...80 °C):**Promass F:* $\pm 0.001 \text{ g/cc}$ *Promass M, A:* $\pm 0.002 \text{ g/cc}$ *Standard calibration:**Promass F:* $\pm 0.01 \text{ g/cc}$ *Promass M, A:* $\pm 0.02 \text{ g/cc}$ *Temperature* $\pm 0.5 \text{ °C} \pm 0.005 \times T$  (T = fluid temperature in °C)

Repeatability

**Mass flow (liquid):***Promass F, M, A:* $\pm 0.05\% \pm [1/2 \times (\text{zero point stability} / \text{measured value}) \times 100]\% \text{ o.r.}$ **Mass flow (gas):***Promass F, M, A:* $\pm 0.25\% \pm [1/2 \times (\text{zero point stability} / \text{measured value}) \times 100]\% \text{ o.r.}$

**Volume flow (liquid):**

*Promass F:*

$\pm 0.05\% \pm [1/2 \times (\text{zero point stability} / \text{measured value}) \times 100]\% \text{ o.r.}$

*Promass M, A:*

$\pm 0.10\% \pm [1/2 \times (\text{zero point stability} / \text{measured value}) \times 100]\% \text{ o.r.}$

o.r. = of reading

Zero point stability: see "Max. measured error"

Calculation example (mass flow, liquid):

Given: Promass 83 F / DN 25, flow = 8000 kg/h

Repeatability:  $\pm 0.10\% \pm [(1/2 \times \text{zero point stability} / \text{measured value}) \times 100]\% \text{ o.r.}$

Repeatability  $\rightarrow \pm 0.10\% \pm 1/2 \cdot 0.54 \text{ kg/h} \div 8000 \text{ kg/h} \cdot 100\% = \pm 0.053\%$

**Density measurement (liquid)**

*Promass F:*

$\pm 0.00025 \text{ g/cc}$  (1 g/cc = 1 kg/l)

*Promass M, A:*

$\pm 0.0005 \text{ g/cc}$

**Temperature measurement**

$\pm 0.25 \text{ }^\circ\text{C} \pm 0.0025 \times T$  (T = fluid temperature in  $^\circ\text{C}$ )

Influence of medium temperature

When there is a difference between the temperature for zero point adjustment and the process temperature, the typical measured error of the Promass sensor is  $\pm 0.0002\%$  of the full scale value /  $^\circ\text{C}$ .

Influence of medium pressure

The tables below show the effect on accuracy of mass flow due to a difference between calibration pressure and process pressure.

*Promass F, M:*

DN	Promass F [% o.r./bar]	Promass M [% o.r./bar]	Promass M / (high pressure) [% o.r./bar]
8	No influence	0.009	0.006
15	No influence	0.008	0.005
25	No influence	0.009	0.003
40	-0.003	0.005	-
50	-0.008	No influence	-
80	-0.009	No influence	-
100	-0.012	-	-
150	-0.009	-	-
250	-0.009	-	-

o.r. = of reading

*Promass A:*

A difference between calibration pressure and process pressure has no effect on measuring accuracy.

### 11.1.7 Operating conditions: Installation

Installation instructions	see Page 14
Inlet and outlet runs	There are no installation requirements regarding inlet and outlet runs.
Length of connecting cable	Max. 20 meters (remote version)
System pressure	see Page 15

### 11.1.8 Operating conditions: Environment

Ambient temperature range	Standard: $-20\dots+60$ °C (sensor, transmitter) Optional: $-40\dots+60$ °C (sensor, transmitter)
 Note!	<ul style="list-style-type: none"> <li>■ Install the device at a shady location. Avoid direct sunlight, particularly in warm climatic regions.</li> <li>■ At ambient temperatures below <math>-20</math> °C the readability of the display may be impaired.</li> </ul>
Storage temperature	$-40\dots+80$ °C (preferably $+20$ °C)
Ambient class	B, C, I
Degree of protection	Standard: IP 67 (NEMA 4X) for transmitter and sensor
Shock resistance	According to IEC 68-2-31
Vibration resistance	Acceleration up to 2 g, 10...150 Hz, following IEC 68-2-6
CIP cleaning	yes
SIP cleaning	yes
Electromagnetic compatibility (EMC)	To EN 61326/A1 and NAMUR recommendation NE 21

### 11.1.9 Operating conditions: Process

Medium temperature range	<p><b>Sensor:</b></p> <p><i>Promass F, A:</i> <math>-50\dots+200</math> °C</p> <p><i>Promass M:</i> <math>-50\dots+150</math> °C</p>
--------------------------	--

**Seals:***Promass F:*

No internal seals

*Promass M:*

Viton -15...200 °C; EPDM -40...+160 °C; silicon -60...+200 °C; Kalrez -20...+275 °C;  
FEP sheathed (not for gas applications): -60...+200 °C

*Promass A*

(only for mounting sets with threaded connections)

Viton -15...200 °C; EPDM -40...+160 °C; silicon -60...+200 °C; Kalrez -20...+275 °C

---

Limiting medium pressure  
range (rated pressure)

The material load diagrams (pressure-temperature diagrams) for the process connections are to be found in the following documents:

- Technical Information Promass 84 F, M (TI067D/06/en)
- Technical Information Promass 80/83 A (TI068D/06/en)

*Pressure ranges of secondary containment:**Promass F:*

DN 8...50: 40 bar or 600 psi; DN 80: 25 bar or 375 psi;  
DN 100...150: 16 bar or 250 psi; DN 250: 10 bar or 150 psi

*Promass M:*

100 bar or 1500 psi

*Promass A:*

25 bar or 375 psi

---

Limiting flow

See "Measuring range" section. → Seite 91 ff.

Pressure loss

Pressure loss depends on the properties of the fluid and on its flow. The following formulas can be used to approximately calculate the pressure loss:

*Pressure loss formulas for Promass F, M*

Reynolds number	$Re = \frac{2 \cdot \dot{m}}{\pi \cdot d \cdot \nu \cdot \rho}$	F06-83xxxxxx-19-xx-xx-xx-000
$Re \geq 2300^{1)}$	$\Delta p = K \cdot \nu^{0.25} \cdot \dot{m}^{1.85} \cdot \rho^{-0.86}$	F06-83xxxxxx-19-xx-xx-xx-001
$Re < 2300$	$\Delta p = K1 \cdot \nu \cdot \dot{m} + \frac{K2 \cdot \nu^{0.25} \cdot \dot{m}^2}{\rho}$	F06-83xxxxxx-19-xx-xx-xx-002
$\Delta p$ = pressure loss [mbar] $\rho$ = fluid density [kg/m3] $\nu$ = kinematic viscosity [m2/s] $d$ = inside diameter of measuring tubes [m] $\dot{m}$ = mass flow [kg/s] $K...K2$ = constants (depending on nominal diameter)		
1) To compute the pressure loss for gases, always use the formula for $Re \geq 2300$ .		

*Pressure loss formulas for Promass A*

Reynolds number	$Re = \frac{4 \cdot \dot{m}}{\pi \cdot d \cdot \nu \cdot \rho}$	F06-83xxxxxx-19-xx-xx-xx-004
$Re \geq 2300^{1)}$	$\Delta p = K \cdot \nu^{0.25} \cdot \dot{m}^{1.75} \cdot \rho^{-0.75} \cdot \frac{K3 \cdot \dot{m}^2}{\rho}$	F06-83xxxxxx-19-xx-xx-xx-005
$Re < 2300$	$\Delta p = K1 \cdot \nu \cdot \dot{m} + \frac{K3 \cdot \dot{m}^2}{\rho}$	F06-83xxxxxx-19-xx-xx-xx-003
$\Delta p$ = pressure loss [mbar] $\rho$ = fluid density [kg/m3] $\nu$ = kinematic viscosity [m2/s] $d$ = inside diameter of measuring tubes [m] $\dot{m}$ = mass flow [kg/s] $K...K3$ = constants (depending on nominal diameter)		
1) To compute the pressure loss for gases, always use the formula for $Re \geq 2300$ .		

*Pressure loss coefficient for Promass F*

DN	d[m]	K	K1	K2
8	$5.35 \cdot 10^{-3}$	$5.70 \cdot 10^7$	$9.60 \cdot 10^7$	$1.90 \cdot 10^7$
15	$8.30 \cdot 10^{-3}$	$5.80 \cdot 10^6$	$1.90 \cdot 10^7$	$10.60 \cdot 10^5$
25	$12.00 \cdot 10^{-3}$	$1.90 \cdot 10^6$	$6.40 \cdot 10^6$	$4.50 \cdot 10^5$
40	$17.60 \cdot 10^{-3}$	$3.50 \cdot 10^5$	$1.30 \cdot 10^6$	$1.30 \cdot 10^5$
50	$26.00 \cdot 10^{-3}$	$7.00 \cdot 10^4$	$5.00 \cdot 10^5$	$1.40 \cdot 10^4$
80	$40.50 \cdot 10^{-3}$	$1.10 \cdot 10^4$	$7.71 \cdot 10^4$	$1.42 \cdot 10^4$
100	$51.20 \cdot 10^{-3}$	$3.54 \cdot 10^3$	$3.54 \cdot 10^4$	$5.40 \cdot 10^3$
150	$68.90 \cdot 10^{-3}$	$1.36 \cdot 10^3$	$2.04 \cdot 10^4$	$6.46 \cdot 10^2$
250	$102.26 \cdot 10^{-3}$	$3.00 \cdot 10^2$	$6.10 \cdot 10^3$	$1.33 \cdot 10^2$

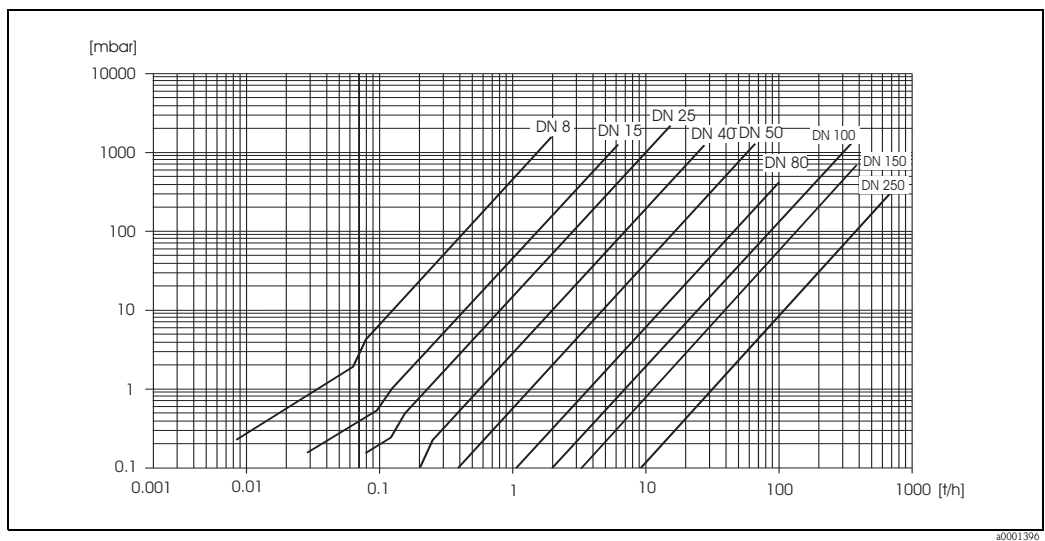

Fig. 43: *Pressure loss diagram for water*

Pressure loss coefficient for Promass M

DN	d[m]	K	K1	K2
8	$5.53 \cdot 10^{-3}$	$5.2 \cdot 10^7$	$8.6 \cdot 10^7$	$1.7 \cdot 10^7$
15	$8.55 \cdot 10^{-3}$	$5.3 \cdot 10^6$	$1.7 \cdot 10^7$	$9.7 \cdot 10^5$
25	$11.38 \cdot 10^{-3}$	$1.7 \cdot 10^6$	$5.8 \cdot 10^6$	$4.1 \cdot 10^5$
40	$17.07 \cdot 10^{-3}$	$3.2 \cdot 10^5$	$1.2 \cdot 10^6$	$1.2 \cdot 10^5$
50	$25.60 \cdot 10^{-3}$	$6.4 \cdot 10^4$	$4.5 \cdot 10^5$	$1.3 \cdot 10^4$
80	$38.46 \cdot 10^{-3}$	$1.4 \cdot 10^4$	$8.2 \cdot 10^4$	$3.7 \cdot 10^4$
High pressure version				
8	$4.93 \cdot 10^{-3}$	$6.0 \cdot 10^7$	$1.4 \cdot 10^8$	$2.8 \cdot 10^7$
15	$7.75 \cdot 10^{-3}$	$8.0 \cdot 10^6$	$2.5 \cdot 10^7$	$1.4 \cdot 10^6$
15	$10.20 \cdot 10^{-3}$	$2.7 \cdot 10^6$	$8.9 \cdot 10^6$	$6.3 \cdot 10^5$

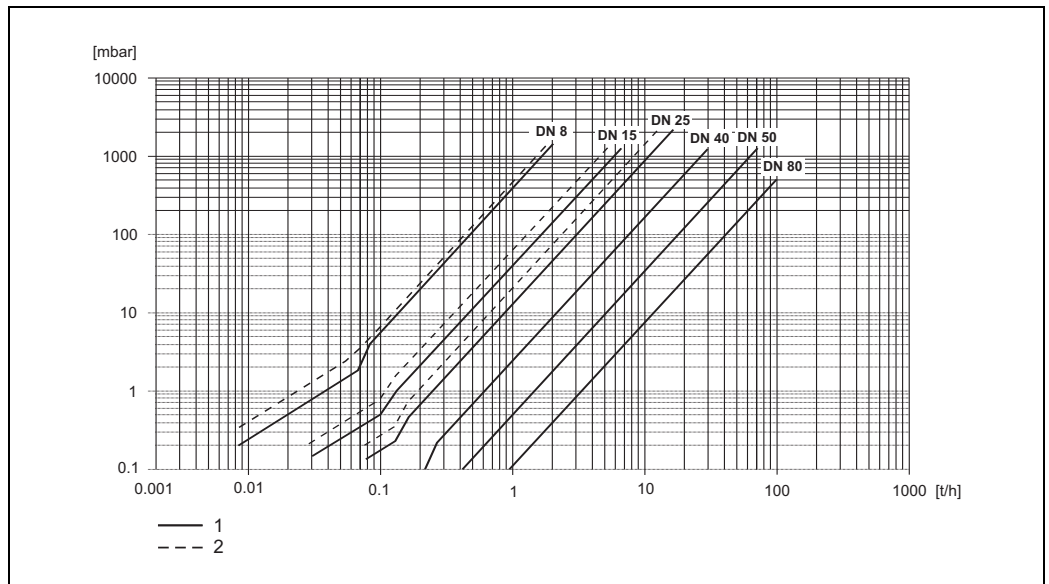
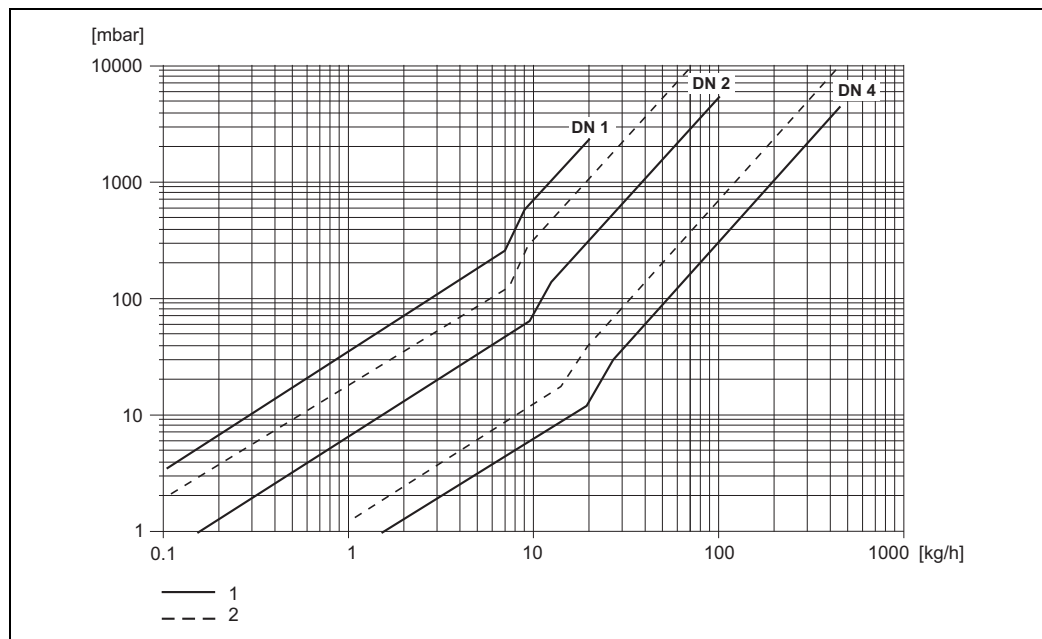

Fig. 44: Pressure loss diagram for water

- 1 Promass M
- 2 Promass M (high pressure version)

*Pressure loss coefficient for Promass A*

DN	d[m]	K	K1	K3
1	$1.1 \cdot 10^{-3}$	$1.2 \cdot 10^{11}$	$1.3 \cdot 10^{11}$	0
2	$1.8 \cdot 10^{-3}$	$1.6 \cdot 10^{10}$	$2.4 \cdot 10^{10}$	0
4	$3.5 \cdot 10^{-3}$	$9.4 \cdot 10^8$	$2.3 \cdot 10^9$	0
High pressure version				
2	$1.4 \cdot 10^{-3}$	$5.4 \cdot 10^{10}$	$6.6 \cdot 10^{10}$	0
4	$3.0 \cdot 10^{-3}$	$2.0 \cdot 10^9$	$4.3 \cdot 10^9$	0



F06-8xAxxxx-05-xx-xx-xx-000

Fig. 45: *Pressure loss diagram for water*

- 1 *Standard version*
- 2 *High pressure version*



### 11.1.10 Mechanical construction

Design / dimensions      Dimensions and the fitting lengths of the transmitter and sensor are given in the Technical Information.

Weight

- Compact version: see table below
- Remote version
  - Sensor: see table below
  - Wall-mount housing: 5 kg

Promass F / DN	8	15	25	40	50	80	100	150	250
Compact version	11	12	14	19	30	55	96	154	400
Compact version, high-temperature	–	–	14.7	–	30.7	55.7	–	–	–
Remote version	9	10	12	17	28	53	94	152	398
Remote version, high-temperature	–	–	13.5	–	29.5	54.5	–	–	–

Promass M / DN	8	15	25	40	50	80
Compact version	11	12	15	24	41	67
Remote version	9	10	13	22	39	65

Promass A / DN	2	4
Compact version	11	15
Remote version	9	13

Weight data in [kg].

All values (weight) refer to devices with EN/DIN PN 40 flanges.

## Material

***Transmitter housing:***

- Compact housing: stainless steel 1.4301/304
- Compact housing: powder coated die-cast aluminium
- Wall-mount housing: powder coated die-cast aluminium
- Remote field housing: powder-coated die-cast aluminium

***Sensor housing / containment:****Promass F:*

Acid- and alkali-resistant outer surface  
 DN 8...50: stainless steel 1.4301/304  
 DN 80...250: stainless steel 1.4301/304 and 1.4308/304L

*Promass M:*

Acid- and alkali-resistant outer surface  
 DN 8...50: steel, chemically nickel-plated  
 DN 80: stainless steel

*Promass A:*

Acid- and alkali-resistant outer surface  
 Stainless steel 1.4301/304

***Connection housing, sensor (remote version):***

- Stainless steel 1.4301/304 (standard)
- powder coated die-cast aluminium (high-temperature version and version for heating)

***Process connections****Promass F:*

- Flanges EN 1092-1 (DIN 2501) / ANSI B16.5 / JIS B2238 \* stainless steel 1.4404/316L
- Flanges EN 1092-1 (DIN 2501) / ANSI B16.5 / JIS B2238 \* Alloy C-22 2.4602/N 06022
- Flange DIN 11864-2 Form A (flat flange) \* stainless steel 1.4404/316L
- Hygienic coupling DIN 11851 / SMS 1145 \* stainless steel 1.4404/316L
- Couplings ISO 2853 / DIN 11864-1 \* stainless steel 1.4404/316L
- Tri-Clamp (OD-tubes)\* stainless steel 1.4404/316L

*Promass M:*

- Flanges EN 1092-1 (DIN 2501) / ANSI B16.5 / JIS B2238 \* stainless steel 1.4404/316L, titanium grade 2
- Flange DIN 11864-2 Form A (flat flange) \* stainless steel 1.4404/316L
- PVDF connection to DIN / ANSI / JIS
- Hygienic coupling DIN 11851 / SMS 1145 \* stainless steel 1.4404/316L
- Couplings ISO 2853 / DIN 11864-1 \* stainless steel 1.4404/316L
- Tri-Clamp (OD-tubes)\* stainless steel 1.4404/316L

*Promass M (high pressure version):*

- Connector \* stainless steel 1.4404/316L
- Couplings \* stainless steel 1.4401/316

*Promass A:*

- Mounting set for flanges EN 1092-1 (DIN 2501) / ANSI B16.5 / JIS B2238 → stainless steel 1.4539/904L, Alloy C-22 2.4602/N 06022.  
Loose flanges → stainless steel 1.4404/316L
- VCO coupling \* stainless steel 1.4539/904L, Alloy C-22 2.4602/N 06022
- Tri-Clamp (OD-tubes) (1/2") \* stainless steel 1.4539/904L
- Mounting set for SWAGelok (1/4", 1/8") \* stainless steel 1.4401/316
- Mounting set for NPT-F (1/4") → stainless steel 1.4539/904L, Alloy C-22 2.4602/N 06022

**Measuring tube(s):***Promass F:*

- DN 8...100: stainless steel 1.4539/904L
- DN 150: stainless steel 1.4404/316L
- DN 250: stainless steel 1.4404/316L; manifold: CF3M
- DN 8...150: Alloy C-22 2.4602/N 06022

*Promass M:*

- DN 8...50: titanium grade
- DN 80: titanium grade 2

*Promass M (high pressure version):*

- Titanium grade 9

*Promass A:*

- Stainless steel 1.4539/904L, Alloy C-22 2.4602/N 06022

**Seals:***Promass F:*

Welded process connections without internal seals

*Promass M:*

Viton, EPDM, silicon, Kalrez, FEP sheathing (not for gas applications)

*Promass A:*

Viton, EPDM, silicon, Kalrez

---

Material load diagram	<p>The material load diagrams (pressure-temperature diagrams) for the process connections are to be found in the following documents:</p> <ul style="list-style-type: none"> <li>■ Technical Information Promass 84 F, M (TI067D/06/en)</li> <li>■ Technical Information Promass 84 A (TI068D/06/en)</li> </ul>
Process connections	see Page 106

---

### 11.1.11 Human interface

Display elements

- Liquid crystal display: illuminated, four lines with 16 characters per line
- Selectable display of different measured values and status variables
- 3 totalizers
- At ambient temperatures below  $-20\text{ }^{\circ}\text{C}$  the readability of the display may be impaired.

Operating elements

- Local operation with three optical sensors (-, +, E)
- Application specific Quick Setup menus for straightforward commissioning

Language groups

Language groups available for operation in different countries:

- Western Europe and America (WEA):  
English, German, Spanish, Italian, French, Dutch and Portuguese
- Eastern Europe and Scandinavia (EES):  
English, Russian, Polish, Norwegian, Finnish, Swedish and Czech
- South and east Asia (SEA):  
English, Japanese, Indonesian
- China (CIN):  
English, Chinese

You can change the language group via the operating program "ToF Tool - Fieldtool Package."

Remote operation

Operation by means of HART protocol

### 11.1.12 Certificates and approvals

Ex approval

Information about currently available Ex versions (ATEX, FM, CSA) can be supplied by your E+H Sales Centre on request. All explosion protection data are given in a separate documentation which is available upon request.

Suitability for custody transfer measurement

PTB and NMi approval for determining the mass and volume of liquids, other than water, and of fuel gases.  
The device is qualified to OIML R117, DIN 19217.

Promass	DN	PTB approval			
		For liquids other than water			For high-pressure gas (CNG)
		Mass counter	Volume counter	Density measuring unit	Mass counter
A	2...4	YES	YES	YES	NO
F	8...250	YES	YES	YES	NO
M	8...50	YES	NO	NO	NO
M	80	YES	YES	YES	NO
M*	8...25	NO	NO	NO	YES
M* (high pressure)	8...25	NO	NO	NO	YES

\* For CNG applications

Promass	DN	NMI approval	
		Mass counter	Volume counter
		For liquids other than water as	
A	2...4	YES	YES
F	8...250	YES	YES
M	8..80	YES	YES
M*	8...25	NO	NO
M* (high pressure)	8...25	NO	NO
* For CNG applications			

## Sanitary compatibility

- 3A approval
- EHEDG-inspected (only Promass A)

## Pressure device approval

Flowmeters with a nominal diameter smaller or equal DN 25 are covered by Art. 3(3) of the European directive 97/23/EC (Pressure Equipment Directive) and are designed according to sound engineer practice. For larger nominal diameters, optional approvals according to Cat. II/III are available when required (depends on fluid and process pressure).

## Functional safety

SIL 2:  
In accordance with IEC 61508/IEC 61511-1 (FDIS)

## CE mark

The measuring system is in conformity with the statutory requirements of the EC Directives. Endress+Hauser confirms successful testing of the device by affixing to it the CE mark.

## Other standards and guidelines

EN 60529:  
Degrees of protection by housing (IP code)

EN 61010  
Protection Measures for Electrical Equipment for Measurement, Control, Regulation and Laboratory Procedures.

EN 61326/A1 (IEC 1326)  
"Emission in accordance with requirements for Class A". Electromagnetic compatibility (EMC-requirements)

NAMUR NE 21:  
Electromagnetic compatibility (EMC) of industrial process and laboratory control equipment.

NAMUR NE 43:  
Standardisation of the signal level for the breakdown information of digital transmitters with analogue output signal.

NAMUR NE 53:  
Software of field devices and signal-processing devices with digital electronics

### 11.1.13 Ordering information

The Endress +Hauser service organisation can provide detailed ordering information and information on the order codes on request.

### 11.1.14 Accessories

Various accessories, which can be ordered separately from Endress+Hauser, are available for the transmitter and the sensor. → Page 73

The Endress+Hauser service organisation can provide detailed information on the order codes of your choice.

### 11.1.15 Documentation

- System Information Promass (SI 032D/06/en)
- Technical Information Promass 84 F, M (TI067D/06/en)
- Technical Information Promass 84 A (TI068D/06/en)
- Description of Device Functions Promass 84 (BA110D/06/en)
- Supplementary documentation on Ex-ratings: ATEX, FM, CSA

## Index

### A

Accessories .....	73
Ambient class .....	99
Ambient temperature range .....	99
Applications .....	7, 90
Applicator (selection and configuration software) .....	74
Approval by the Standards Authorities .....	67
Approval for custody transfer .....	67
Approvals .....	11

### B

Blocks .....	34
--------------	----

### C

Cable entry	
Degree of protection .....	29
Technical data .....	94
Cable specifications (remote version) .....	25
CE mark (declaration of conformity) .....	11
Certificates .....	11
CIP cleaning .....	72
Cleaning	
CIP cleaning .....	72, 99
External cleaning .....	72
SIP cleaning .....	72
Code entry (function matrix) .....	35
Commissioning	
Two current outputs .....	61
Zero point adjustment .....	63
Commubox FXA 191 (electrical connection) .....	28
Communication .....	37
Connection	
See Electrical connection	
Current output	
Technical data .....	93
Current outputs, two	
Configuration active/passive .....	61
Custody transfer	
Approval .....	67
Definition of terms .....	68
Disabling custody transfer mode .....	71
Measurement .....	67
Setting up custody transfer mode .....	69
Verification process .....	69
Custody transfer measurement .....	67

### D

Data back-up .....	60
Declaration of conformity (CE mark) .....	11
Definition of terms (custody transfer) .....	68
Degree of protection .....	29, 99
Designated use .....	7, 90
Device description files .....	39
Device designation .....	9, 90
Device functions	
See "Description of Device Functions" manual	
Disabling custody transfer mode .....	71

### Display

Turning the display .....	23
Disposal .....	89
Documentation .....	110

### E

Electrical connection	
Cable specifications (remote version) .....	25
Commubox FXA 191 .....	28
Degree of protection .....	29
HART handheld terminal .....	28
Remote version .....	24
Error limits	
See Performance characteristics	
Error messages	
Confirming error messages .....	36
Process error (application error) .....	80
System error (device error) .....	76
Error types (system and process errors) .....	36
European Pressure Equipment Directive .....	109
Ex approval .....	108
External cleaning .....	72

### F

Fieldcare .....	38
Flow direction .....	16–17
Frequency output	
Technical data .....	93
Function check .....	52
function description	
See "Description of Device Functions" manual	
Function groups .....	34
Functions .....	34
Fuse, replacing .....	88

### G

Galvanic isolation .....	94
Groups .....	34

### H

HART	
Command classes .....	37
Command No. ....	41
Electrical connection .....	28
Error messages .....	41
Handheld terminal .....	38
Hazardous substances .....	8, 89
HOME position (display operating mode) .....	31

<b>I</b>	
Incoming acceptance .....	13
Inlet and outlet runs .....	99
Inlet runs .....	18
Input signal .....	93
Installation .....	99
Installation conditions	
Inlet and outlet runs .....	18
Installation dimensions .....	14
Mounting location .....	14
Orientation (vertical, horizontal) .....	16
System pressure .....	15
Vertical pipe .....	14
Vibrations .....	19
Installation instructions .....	99
Installing the wall-mount transmitter housing .....	21
Insulation of sensors .....	18
<b>L</b>	
Language groups .....	108
Length of connecting cable .....	99
Limiting flow	
See Measuring range	
Load .....	93
Local display	
See Display	
Low flow cut off .....	94
<b>M</b>	
Maintenance .....	72
Material .....	106
Material load diagram .....	100, 107
Measured variable .....	90
Measuring principle .....	90
Measuring range .....	91–93
Measuring system .....	9, 90
Medium pressure range .....	100
Medium temperature range .....	99
Mounting	
See Installation conditions	
<b>N</b>	
Nameplate	
Connections .....	11
Sensor .....	10
Nominal pressure	
See Medium pressure range	
<b>O</b>	
Operable flow range .....	93
Operating conditions .....	99
Operation	
Device description files .....	39
Fieldcare .....	38
HART handheld terminal .....	38
ToF Tool - Fieldtool Package (configuration and service software) .....	38
Operational safety .....	7
Order code	
Accessories .....	73

Sensor .....	11
Transmitter .....	9–10
Ordering information .....	109
Outlet runs .....	18
Output signal .....	93
<b>P</b>	
Performance characteristics	
Influence of medium pressure .....	98
Influence of medium temperature .....	98
Maximum measured error .....	95
Reference operating conditions .....	95
Repeatability .....	97–98
Post-installation check (checklist) .....	23
Power consumption .....	94
Power supply (supply voltage) .....	94
Power supply failure .....	94
Pressure device approval .....	109
Pressure loss (formulas, pressure loss diagrams) .....	101
Pressure monitoring connections .....	66
Printed circuit boards (installation/removal)	
Field housing .....	84
Wall-mount housing .....	86
Process connections .....	107
Process error	
Definition .....	36
Process error messages .....	80
Programming mode	
Enabling .....	35
Pulse output	
See Frequency output	
Pumps, mounting location, system pressure .....	15
Purge connections .....	66
<b>R</b>	
Registered trademarks .....	12
Remote operation .....	108
Repair .....	8, 89
Repeatability (performance characteristics) .....	97–98
Repeated calibration due to legal metrology controls .....	67
Replacement	
Printed circuit boards (installation/removal) .....	84, 86
Seals .....	72
Returning devices .....	8, 89
<b>S</b>	
Safety icons .....	8
Safety instructions .....	7
Sanitary compatibility .....	109
S-DAT (HistoROM) .....	66
Seals	
Material .....	107
Medium temperature range .....	100
Replacing, replacement seals .....	72
Secondary containment	
Gas purging, pressure monitoring connections .....	66
Pressure range .....	100
Sensor heating .....	18
Sensor installation	
See Installation conditions	



Serial number .....	9–11
Setting up custody transfer mode .....	69
Shock resistance .....	99
Signal on alarm .....	93
SIL (functional safety) .....	7, 109
SIP cleaning .....	72
Software	
Amplifier display .....	52
Versions (history) .....	89
Spare parts .....	83
Standards, guidelines .....	109
Status input	
Technical data .....	93
Storage .....	14
Suitability for custody transfer measurement .....	67
Supplementary Ex documentation .....	7
Supply voltage (power supply) .....	94
System error	
Definition .....	36
System error messages .....	76
<b>T</b>	
T-DAT .....	60
T-DAT (HistoROM) .....	66
Technical data at a glance .....	90
Temperature ranges	
Ambient temperature range .....	99
Medium temperature range .....	99
Storage temperature .....	99
Thermal insulation, general notes .....	18
ToF Tool - Fieldtool Package .....	38, 74
Transmitter	
Electrical connection .....	25
Installing the wall-mount transmitter housing .....	21
Turning the field housing (aluminium) .....	20
Turning the field housing (stainless steel) .....	20
Transporting the sensor .....	13
Trouble-shooting and remedy .....	75
<b>V</b>	
Verification process (custody transfer) .....	69
Vertical pipe .....	14
Vibration resistance .....	99
Vibrations .....	19, 99
<b>W</b>	
Wall-mount housing, installing .....	21
Weight .....	105
Wiring	
See Electrical connection	
<b>Z</b>	
Zero point adjustment .....	63



# Declaration of Contamination

## Erklärung zur Kontamination

Because of legal regulations and for the safety of our employees and operating equipment, we need the "declaration of contamination", with your signature, before your order can be handled. Please make absolutely sure to include it with the shipping documents, or - even better - attach it to the outside of the packaging.

*Aufgrund der gesetzlichen Vorschriften und zum Schutz unserer Mitarbeiter und Betriebseinrichtungen, benötigen wir die unterschriebene "Erklärung zur Kontamination", bevor Ihr Auftrag bearbeitet werden kann. Legen Sie diese unbedingt den Versandpapieren bei oder bringen Sie sie idealerweise außen an der Verpackung an.*

**Type of instrument / sensor**

Geräte-/Sensortyp \_\_\_\_\_

**Serial number**

Seriennummer \_\_\_\_\_

**Process data/ Prozessdaten**

Temperature / Temperatur \_\_\_\_\_ [°C] Pressure / Druck \_\_\_\_\_ [ Pa ]

Conductivity / Leitfähigkeit \_\_\_\_\_ [ S ] Viscosity / Viskosität \_\_\_\_\_ [mm<sup>2</sup>/s]

**Medium and warnings**

Warnhinweise zum Medium

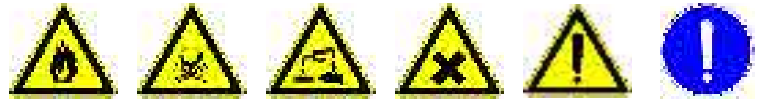

	Medium /concentration Medium /Konzentration	Identification CAS No.	flammable entzündlich	toxic giftig	corrosive ätzend	harmful/ irritant gesundheitsschädlich/ reizend	other * sonstiges*	harmless unbedenklich
Process medium Medium im Prozess								
Medium for process cleaning Medium zur Prozessreinigung								
Returned part cleaned with Medium zur Endreinigung								

\* explosive; oxidising; dangerous for the environment; biological risk; radioactive

\* explosiv; brandfördernd; umweltgefährlich; biogefährlich; radioaktiv

Please tick should one of the above be applicable, include security sheet and, if necessary, special handling instructions.

*Zutreffendes ankreuzen; trifft einer der Warnhinweise zu, Sicherheitsdatenblatt und ggf. spezielle Handhabungsvorschriften beilegen.*

**Reason for return / Grund zur Rücksendung** \_\_\_\_\_

\_\_\_\_\_

**Company data / Angaben zum Absender**

Company / Firma _____	Contact person / Ansprechpartner _____
_____	Department / Abteilung _____
Address / Adresse _____	Phone number/ Telefon _____
_____	Fax / E-Mail _____
_____	Your order No. / Ihre Auftragsnr. _____

We hereby certify that the returned parts have been carefully cleaned. To the best of our knowledge they are free from any residues in dangerous quantities.

*Hiermit bestätigen wir, dass die zurückgesandten Teile sorgfältig gereinigt wurden, und nach unserem Wissen frei von Rückständen in gefahrbringender Menge sind.*

\_\_\_\_\_ (place, date / Ort, Datum)

\_\_\_\_\_ (Company stamp and legally binding signature)  
(Firmenstempel und rechtsverbindliche Unterschrift)

[www.endress.com/worldwide](http://www.endress.com/worldwide)

---

**Endress+Hauser**   
People for Process Automation