

# HEAVY-DUTY COMMERCIAL GAS WATER HEATER SPARK IGNITION

## 3-Year Tank Warranty

## 1-Year Parts Warranty

- **2" Non-CFC Foam Insulation**

*Foam insulation saves fuel by retarding heat loss.*

- **Fused Ceramic Shield**

*Applied under pressure and fired at 1600°F to completely cover the tank interior. This provides a tough interior surface for storage tanks and maximum protection against the wearing effects of high-volume and high-temperature hot water.*

- **Self-Cleaning LimeFighter™**

*Reduces scale and corrosive deposits that are detrimental to the life cycle of commercial water heaters.*

- **Cleanout Opening**

- **24-Volt Thermostat Control**

*Adjustable to temperatures up to 180°F. A recycling energy cut-off (ECO) control shuts off gas in the event of an overheat condition.*

- **Electronic Thermister Sensor**

*For consistent water temperature control.*

- **Power Cord**

*Supplied and wired for easy installation and service or can be hard wired.*

- **Multiple Anode Rods**

*Promote longer tank life through even distribution, for protection against corrosion of tank interior.*

- **Factory-Installed Temperature and Pressure Relief Valve**

- **Electronic Intermittent Spark Ignition**

*Eliminates standing pilot light for maximum energy efficiency.*

- **Motorized Flue Damper**

*Reduces tank heat loss during standby periods for lowest operating costs.*

- **Design Certified**

*By CSA International for up to 180°F as an automatic storage heater in compliance with ANSI Z-21.10.3•CSA 4.3 test requirements.*

- **ASHRAE Standard 90.1 1989 addendum 90.1b.**

*Thermal efficiency and standby requirements are met or exceeded.*

- **California (CEC) and New York**

*Energy requirements met or exceeded.*

Copyright© by American Water Heater Company 2005.  
All rights reserved.



### **3-Year Limited Tank Warranty**

*Heavy gauge steel is automatically formed, rolled and welded to assure continuous seams for Fused Ceramic Shield™ lining. Each tank is triple tested to ensure quality.*

### **1-Year Parts Warranty**

*Original factory parts warranted for 1 year.*

*For complete warranty information consult the written warranty of American Water Heater Company at (800) 999-9515.*

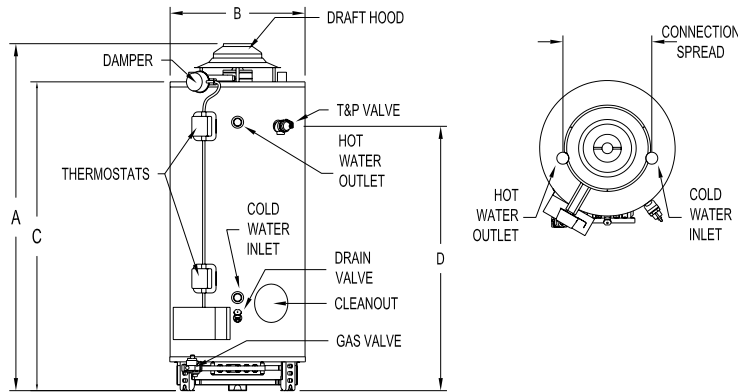

**ELECTRICAL REQUIREMENTS:**  
Need 120 Volt 60 Cycle AC Power Source.  
Draws less than 5 amps.

## Commercial Gas Dampered

Dimensions on all charts shown in inches.

MODEL NUMBER	GAL. CAP.	BTU INPUT NATURAL	BTU INPUT PROPANE	GPH RECOVERY NATURAL 100° RISE	GPH RECOVERY PROPANE 100° RISE	HEIGHT TOP OF VENT A	JACKET DIAM. B	HEIGHT TOP OF HEATER C	VENT SIZE	TOP NIP. SIZE	FRONT CONN. SIZE	HGT. TOP NIP.	TOP NIPPLE SPREAD	HEIGHT FRONT HOT	HEIGHT FRONT COLD	HEIGHT GAS CONN.	SIZE GAS CONN. D	HEIGHT T&P OPEN	T&P OPEN	APPROX SHIP WEIGHT
DCG32-80T199-6N	80	199,999	190,000	194	184	72 3/8	28 1/4	64 1/2	6	1 1/2	1 1/2	66 1/4	18 1/2	56	19 1/2	4 3/4	3/4	56	3/4	540
DCG32-80T250-6N	80	250,000	235,000	242	228	72 3/8	28 1/4	64 1/2	6	1 1/2	1 1/2	66 1/4	18 1/2	56	19 1/2	4 3/4	3/4	56	1	540

To order propane models, change "N" suffix to "P." Limited warranty on tank and parts. Complete details in manual.  
Dimensions and specifications subject to change without notice in accordance with our policy of continuous product improvement.  
For Low NOx (SCAQMD Rule 1146.2) substitute "NOX" for "N" in model number.

RECOVERY IN GALLONS AT VARIOUS TEMPERATURE RISES													
MODEL NUMBER	GAS TYPE	BTU INPUT	TEMPERATURE RISE										
			40°	50°	60°	70°	80°	90°	100°	110°	120°	130°	140°
DCG32-80T199-6N/P	NAT/PRO	199,999	485	388	322	277	242	215	194	176	162	149	139
DCG32-80T250-6N	NATURAL	250,000	605	484	402	346	303	269	242	220	202	186	173
DCG32-80T250-6P	PROPANE	235,000	570	456	378	326	285	253	228	207	190	175	163

Recoveries are based on thermal efficiencies ranging up to 80%. Recovery figures shown on water heater rating plates are based on 78% thermal efficiency in compliance with ANSI Z21.10.3-CSA4.3 requirements.

### Specification

Furnish and install, where indicated, in accordance with manufacturer's instructions and in compliance with all rules and regulations of authorities having jurisdiction.

Commercial gas-fired water heater(s) shall be American® Model \_\_\_\_\_ by American Water Heater Company designed to burn \_\_\_\_\_ gas and certified by CSA International under Volume III tests for commercial water heater(s) having delivery capabilities of 180° F water, shall be approved by the National Sanitation Foundation (NSF) and meet or exceed all applicable energy codes. Water heater(s) shall have a storage capacity of \_\_\_\_\_ gallons, a minimum input rating of \_\_\_\_\_ Btuh and a recovery rating of \_\_\_\_\_ GPH (based upon 80% thermal efficiencies) at a \_\_\_\_\_ ° F temperature rise. Water heater(s) steel tank is hydrostatic tested at 300 PSI having a working pressure of 150 PSI and shall have a Fused Ceramic Shield™ internally lined tank applied under pressure and fired at 1600° F allowing for maximum protection. Water heater(s) shall be equipped with a cleanout, a commercial LIMEFIGHTER™ to help reduce scale and corrosive deposits within the water heater, and an AGA/CSA/CGA approved pressure and temperature relief valve factory installed. Water heater(s) shall be equipped with a 24-volt integrated control circuit consisting of a 180° F adjustable thermostat with upper and lower sensors to maintain an average water temperature throughout the tank allowing maximum water temperature control. Water heater(s) shall be provided with a recycling energy cut-off (ECO) device, gas pressure regulator set for the type of gas supplied, IID electronic ignition, agency-approved flue damper and draft diverter, and anodes for cathodic protection. The outer jacketing shall have a baked enamel finish. The tank shall be foam insulated with an EPA-approved, non-CFC material. Water heater(s) shall be manufactured in United States of America and shall have a 3-year limited tank warranty against corrosion as outlined in the written warranty. Fully illustrated operation, installation and service manual included with unit.

ADDITIONAL SPECIFICATIONS FOR ASME-CODED COMMERCIAL WATER HEATER(S)  
Commercial gas-fired water heater(s) shall be American® Model \_\_\_\_\_ by American Water Heater Company, having an input of 200,000 Btuh or greater, shall be ASME certified, and a stamped National Board labeling permanently affixed to the tank and accessible for inspection.

### Order Entry and Sales

P.O. Box 4056, 500 Princeton Road  
Johnson City, TN 37602-4056  
(800) 937-1037  
(800) 581-7224 fax

### Product Service and Support

P.O. Box 1597, 500 Princeton Road  
Johnson City, TN 37605-1597  
(800) 456-9805  
(800) 999-5210 fax

**Distributed By**