

**Exhibit A**

**ELM PARK COMMUNITY ASSOCIATION  
Property Improvement Form**

Today's Date: \_\_\_\_\_ Property address: \_\_\_\_\_

Owner/Applicant's Name: \_\_\_\_\_

Mailing Address (if different than property address): \_\_\_\_\_

Daytime Phone: \_\_\_\_\_ Evening Phone: \_\_\_\_\_

Type of work (Please check appropriate items):

**Architectural**

**Landscape**

**Equipment**

- |                                            |                                                                                            |                                           |
|--------------------------------------------|--------------------------------------------------------------------------------------------|-------------------------------------------|
| <input type="checkbox"/> Deck              | <input type="checkbox"/> Landscape/Hardscape (circle one)                                  | <input type="checkbox"/> Play Equipment   |
| <input type="checkbox"/> Gazebo            | <input type="checkbox"/> Removal of Exist <input type="checkbox"/> New Install             | <input type="checkbox"/> Pool & Equipment |
| <input type="checkbox"/> Room Addition     | <input type="checkbox"/> Front <input type="checkbox"/> Rear <input type="checkbox"/> Side | <input type="checkbox"/> Spa & Equipment  |
| <input type="checkbox"/> Patio Cover(s)    | <input type="checkbox"/> Irrigation / Drains (circle one)                                  | <input type="checkbox"/> Water Feature    |
| <input type="checkbox"/> Chimney           | <input type="checkbox"/> Fence(s) / Wall(s) / Gate(s) (circle one)                         | <input type="checkbox"/> Barbeque/Counter |
| <input type="checkbox"/> Painting          | <input type="checkbox"/> Front <input type="checkbox"/> Side                               | <input type="checkbox"/> Fire Pit         |
| <input type="checkbox"/> Garage Door       | <input type="checkbox"/> Rear <input type="checkbox"/> Retaining                           | <input type="checkbox"/> Lighting         |
| <input type="checkbox"/> Outdoor Fireplace | <input type="checkbox"/> Extension                                                         | <input type="checkbox"/> Satellite Dish   |
| <input type="checkbox"/> Other: _____      |                                                                                            | <input type="checkbox"/> Other: _____     |

**Attach three (3) sets of plans and specifications, including elevations and cross-sections as needed to describe the project.**

**Fee \$ 0**

**Deposit \$ 0**

Include the submittal date and the property address on each sheet. Please fold to 8½ x 11 inches.

\_\_\_\_\_  
Owner's Signature

**OWNER'S SIGNATURE ABOVE SIGNIFIES ACCEPTANCE AND UNDERSTANDING  
OF THE GUIDELINES, CC&R'S AND EACH EXHIBIT ATTACHED HERETO.**

DATE: \_\_\_\_\_

PROPERTY ADDRESS: \_\_\_\_\_

**Do not write below this line**

---

- **Disapproved as presented (List Reasons/Specific Guidelines Not Met)**

---



---



---

- **Approved as presented**
- **Approved as revised/Conditional Approval:**

---



---

**Committee Signature** \_\_\_\_\_ **Date** \_\_\_\_\_

**Committee Signature** \_\_\_\_\_ **Date** \_\_\_\_\_

**Committee Signature** \_\_\_\_\_ **Date** \_\_\_\_\_

General Conditions and Disclaimers:

1. Committee approval does not waive or constitute or reflect compliance with any federal, state, or local law, ordinance, or code. Approval by the Committee does not relieve or satisfy an Owner’s obligation to comply with all government laws and regulations affecting use of premises, subject to any approved plans. Approval by the Committee does not constitute approval by the city or county; and approval by the city or county does not constitute approval by the Committee.
2. Committee approval does not constitute acceptance of any technical or engineering specifications; and the Association assumes no responsibility for such. The property owner is responsible for all technical and engineering specifications. Approval by the Committee does not warrant structural safety, conformance with building codes or other applicable governmental requirements. The Committee reviews for aesthetic purposes only.
3. Any oversight of a provision of the governing documents, or a provision of the Guidelines/Standards, does not waive the rule. Corrections may be required. Only improvements depicted on the plans can be reviewed by the Committee. The Owner is responsible to ensure all improvements are depicted on the plans submitted. Any improvements not depicted on the plans are not approved. Any change(s) to approved plans shall be deemed unapproved until resubmitted and approved. Approval of plans and specifications shall apply only to the property for which approval is granted and is not authorization to proceed with Improvements on any property other than the property reviewed by the Committee and owned by the Applicant.
4. The use of a neighbor’s yard for construction access is not permitted unless the neighbor has given written consent that includes a description of the access area. Access or storage of equipment used during the course of construction must be through the homeowner’s property only. Property owned and/or maintained by the Association shall not be used for construction access or storage, unless Owner obtains prior written authorization from Association, the Owner agrees in writing to indemnify Association for damage to property owned and/or maintained by Association which is damaged as a result of an Owner’s project, and Owner posts a construction deposit for restoration of damage to property owned and/or maintained by Association.
5. Owner is financially responsible for any repairs and/or replacement to property owned and/or maintained by Association which is damaged as a result of an Owner’s project.

DATE: \_\_\_\_\_

PROPERTY ADDRESS: \_\_\_\_\_

6. Building materials may not be stored on streets, sidewalks, or on property owned and/or maintained by the Association. Streets may not be obstructed by construction equipment. All rubbish, debris and unsightly material or objects of any kind shall be regularly removed from the property and shall not allowed to accumulate thereon.
7. The property owner is financially responsible for any repairs to property owned and/or maintained by the Association damaged by a property owner's project.
8. Approval of plans and specifications is not authorization to proceed with Improvements on any property other than the property reviewed by the Committee and owned by the Applicant.
9. Approval of plans and specifications is not authorization to revise the original drainage system installed by the Builder and approved by the City.
10. Applicant understands and agrees that Applicant must comply with all of the provisions of the Guidelines/Standards.
11. All of the provisions of the Guidelines/Standards (including, but not limited to, the Conditions of Approval) are the provisions of the governing documents regarding Design/Architectural Review; and are incorporated herein by this reference. The applicant has read and understands all provisions and agrees to comply therewith. Approval of plans is subject to and does not constitute a waiver of the terms and provisions of the Association's Declaration, Supplemental Declaration, Guidelines/Standards, Rules and Regulations or other Operative/Governing Documents. Any violation of the Governing Documents must be corrected upon notice of violation.
12. In the event that the City and/or County requires modifications to the plans and specifications previously approved by the Committee, the Owner shall submit to the Committee all modifications to the plans. The Committee shall have the right to review and impose further conditions on such modifications which are not inconsistent with the requirements imposed by the City and/or County. The Committee shall have the right to impose conditions of approval of proposed Improvements which are more restrictive than conditions as may be imposed by the City and/or County. The Committee shall have the right to impose conditions of approval of proposed Improvements which are more restrictive than conditions as may be imposed by the City and/or County.
13. It is the responsibility of the requesting owner to obtain all appropriate signatures on the Neighbor Awareness form INCLUDING revised signatures for any later changes to the improvements reflected thereon. Any failure to obtain all appropriate signatures could render an approval from the committee void.
14. Failure to comply with and satisfy all procedural requirements for an application may void approval.

**ELM PARK COMMUNITY ASSOCIATION**

**REQUIRED WITH PAINTING APPLICATION**

*Indicate the name and number of the paint color in the appropriate boxes.*

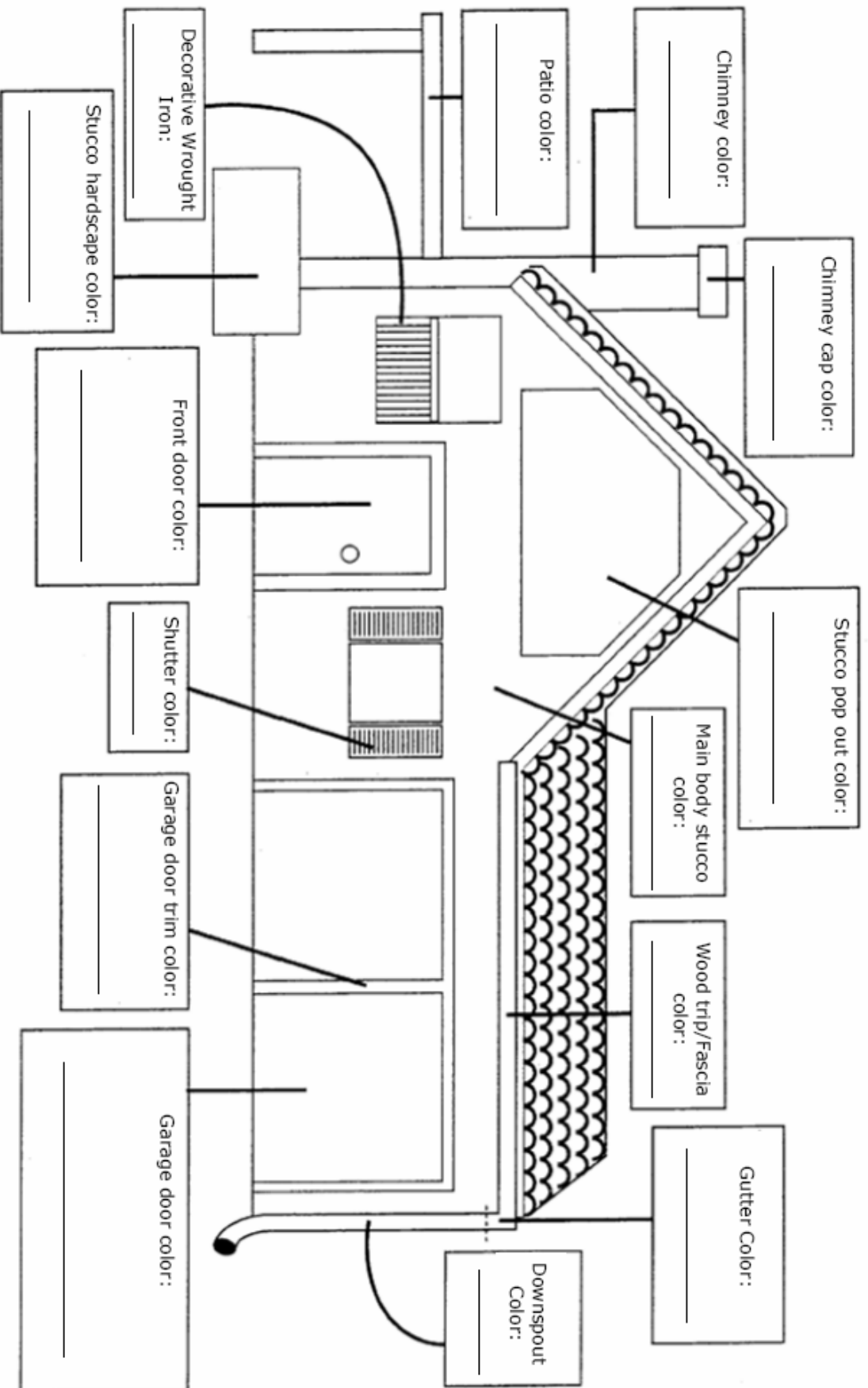

DATE: \_\_\_\_\_

PROPERTY ADDRESS: \_\_\_\_\_

\_\_\_\_\_

\_\_\_\_\_

\_\_\_\_\_

**Exhibit B**

***ELM PARK COMMUNITY ASSOCIATION***  
**Notice of Completion Form**

Today's Date: \_\_\_\_\_ Property address: \_\_\_\_\_

Owner's Name: \_\_\_\_\_

Mailing Address (if different than property address): \_\_\_\_\_

Daytime Phone: \_\_\_\_\_ Evening Phone: \_\_\_\_\_

ATTACH PHOTOGRAPHS OF ALL ANGLES OF IMPROVEMENTS, INCLUDING BOTH  
FRONT, SIDE AND REAR YARD, IF APPLICABLE.

MAIL TO:  
ELM PARK COMMUNITY ASSOCIATION  
c/o Keystone Pacific Property Management  
16775 Von Karman Avenue, Suite 100  
Irvine, California 92606-2600

E-MAIL TO:  
architectural@keystonepacific.com

**Do not write below this line**

---

- Disapproved as presented**
- 

- Approved as presented**
  - Approved as revised:**
- 

**Committee Signature** \_\_\_\_\_ **Date** \_\_\_\_\_

**Committee Signature** \_\_\_\_\_ **Date** \_\_\_\_\_

**Committee Signature** \_\_\_\_\_ **Date** \_\_\_\_\_

**Exhibit C1**

***ELM PARK COMMUNITY ASSOCIATION***  
**Variance Request Form**  
**FEE \$25**

Today's Date: \_\_\_\_\_ Property address: \_\_\_\_\_

Owner/Applicant's Name: \_\_\_\_\_

Mailing Address (if different than property address): \_\_\_\_\_

Daytime Phone: \_\_\_\_\_ Evening Phone: \_\_\_\_\_

**Description of Request (Please include drawings, photographs and a description of your special circumstance for the Board's review):**

\_\_\_\_\_  
\_\_\_\_\_  
\_\_\_\_\_  
\_\_\_\_\_

**Do not write below this line**

---

- Disapproved as presented**
- Approved as presented**
- Approved as revised:**

---

**Committee Signature** \_\_\_\_\_ **Date** \_\_\_\_\_

**Committee Signature** \_\_\_\_\_ **Date** \_\_\_\_\_

**Committee Signature** \_\_\_\_\_ **Date** \_\_\_\_\_

**Exhibit C2**

*ELM PARK COMMUNITY ASSOCIATION*  
APPLICATION FOR APPEAL OF ARCHITECTURAL DENIAL  
**FEE \$25**

The undersigned Owner, by completion of this form, hereby requests that the Association's Board of Directors reconsider the denial of certain Architectural improvements by the Committee, as described below.

1. **Owner's Name:** \_\_\_\_\_

2. **Property Address:** \_\_\_\_\_

3. **Summary of Prior Architectural Submittals:**

(a) Date of Original Submittal: \_\_\_\_\_

(b) Total Number of Submittals: \_\_\_\_\_

(c) Date of Submittal Being Appealed: \_\_\_\_\_

(d) Date of Denial by Committee: \_\_\_\_\_

4. **Copies of Application Information:**

I have included copies of all of the following for the denial that is being appealed:

Copy of original Architectural application;

Copy of Committee denial;

Copy of most recent Architectural plans;

Letter explaining in detail the portion of the Committee denial that you are appealing and explaining the reasons for reversal of the decision. (Please understand that the Board of Directors needs to understand specifically those improvements that the requesting member wishes the Board to reconsider and approve.)

Dated: \_\_\_\_\_

\_\_\_\_\_  
SIGNATURE OF OWNER(S)

**Do not write below this line**

---

- **Disapproved as presented**
- **Approved as presented**
- **Approved as revised:**

---

Board Signature \_\_\_\_\_ Date \_\_\_\_\_

Board Signature \_\_\_\_\_ Date \_\_\_\_\_

Board Signature \_\_\_\_\_ Date \_\_\_\_\_

Exhibit D

SAMPLE PLANTING PLAN

SAMPLE PLANTING PLAN

- Use symbols or numbers to represent individual plants, drawn to approximate spread at maturity.
- Plans should show complete coverage of areas to be landscaped.
- Include a legend with both botanical and common names.

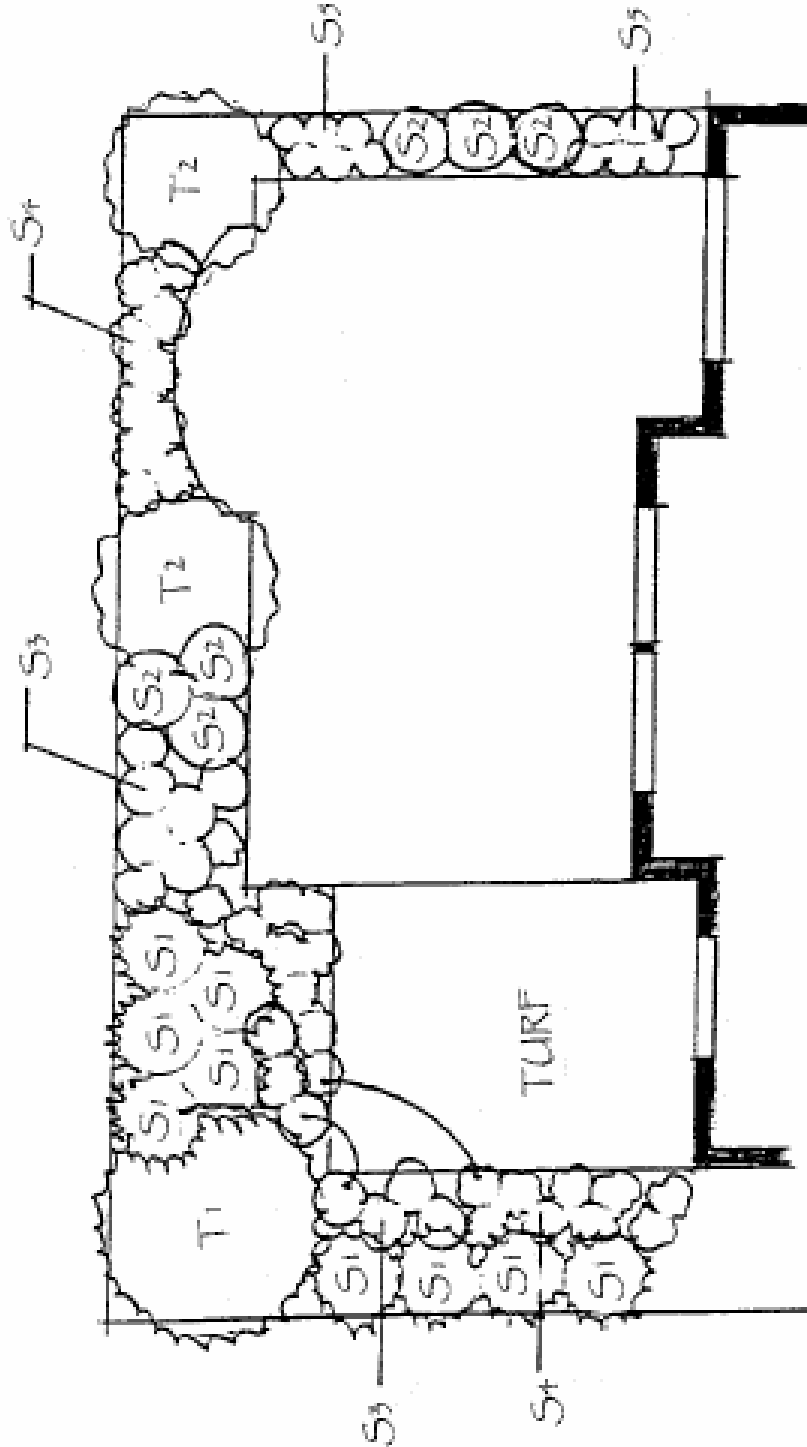

PLANTING LEGEND

SYM.	BOTANICAL NAME	COMMON NAME	SIZE	QTY.
T1	AGONIS FLEXUOSA	PEPPERMINT TREE	36" BOX	1
T2	FEUJOA SELLOWIANA	PINEAPPLE GUAVA	24" BOX	2
S1	PHORMIUM TENAX	NEW ZEALAND FLAX	5 GAL	9



DESIGNATE  
TREE LOCATIONS

CATCH BASIN

DECK DRAIN

DRAINLINE  
INDICATE SIZE

ATRIUM DRAIN

DESIGNATE  
EXISTING TREES

PLANT MATERIALS LIST:  
TREES:

VINES/ESPALIERS:

# PLANTING AND DRAINAGE PLAN

INDICATE ON PLAN WHETHER OR  
NOT YOUR EXISTING DRAINAGE  
WILL BE MAINTAINED OR YOU WILL  
USE DRAINAGE DEVICES TO  
DRAIN YOUR LOT

NAME:  
ADDRESS:  
TRACT NO:  
HOME BUILDER NAME:

SHRUBS:

GROUNDCOVERS:

DRAWING SCALE:  
DATE:

ATRIUM DRAIN

CATCH BASIN

EXISTING  
STREET  
TREES

DESIGNATE  
CURB CORE  
LOCATIONS

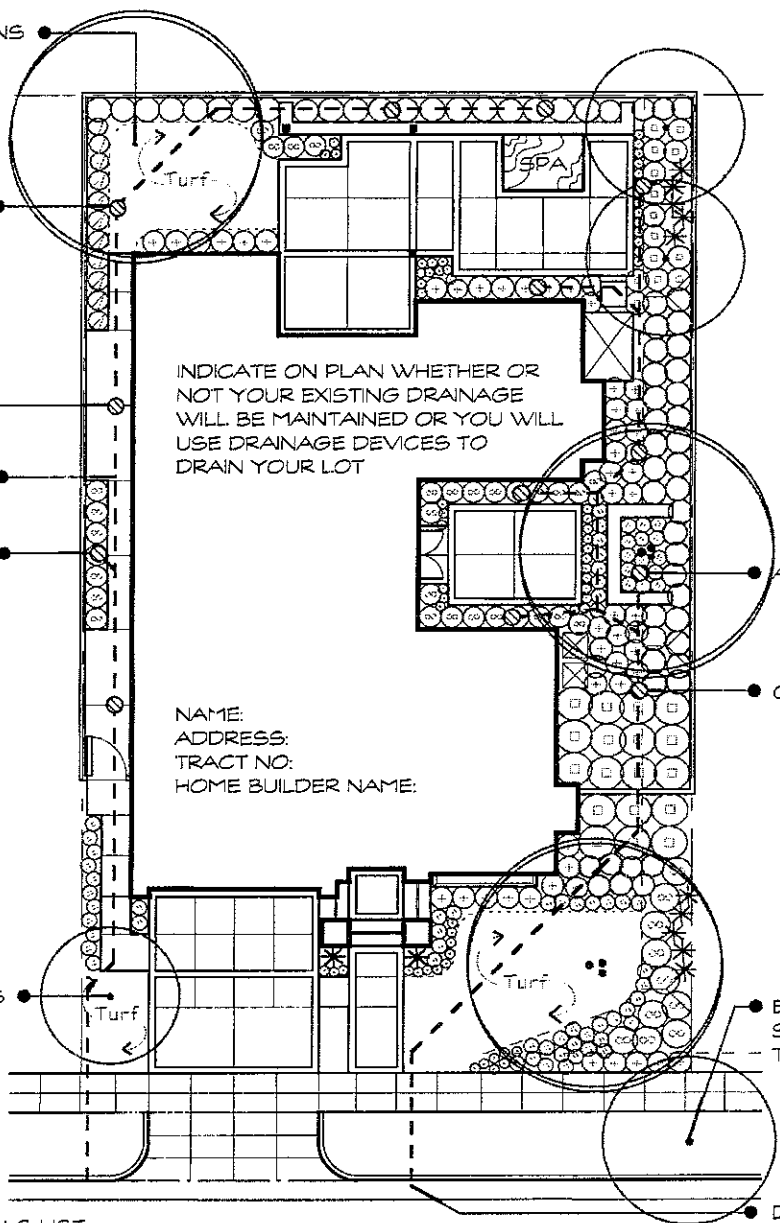

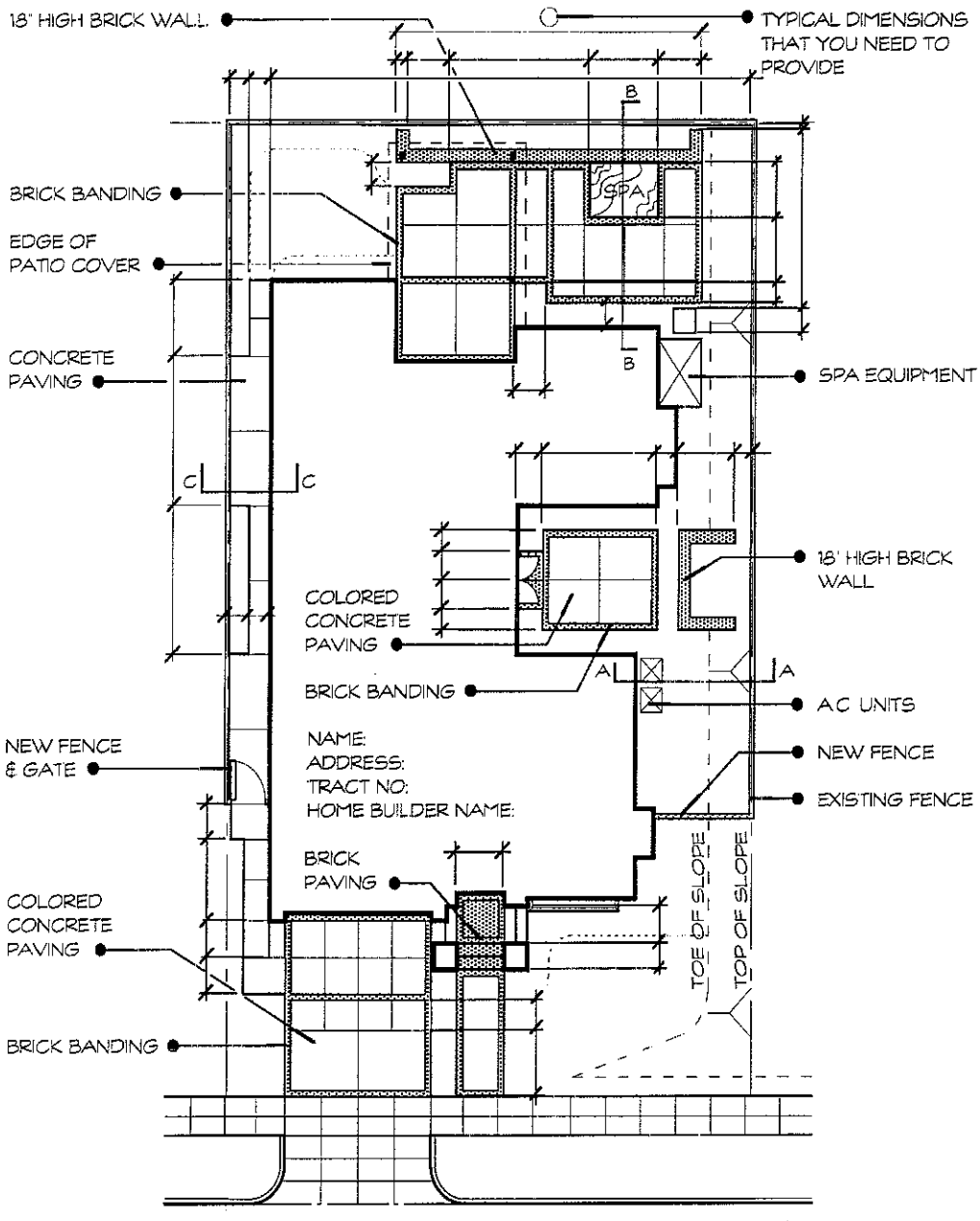

**MATERIALS LIST**

**CONCRETE:**

- COLOR
- SURFACE FINISH:

**BRICK:**

- TYPE:
- COLOR:

**WOOD PATIO COVER:**

- WOOD TYPE:
- COLOR/FINISH:

**WOOD FENCE:**

- WOOD TYPE:
- COLOR/FINISH:

**CONSTRUCTION PLAN**

DRAWING SCALE:

DATE:

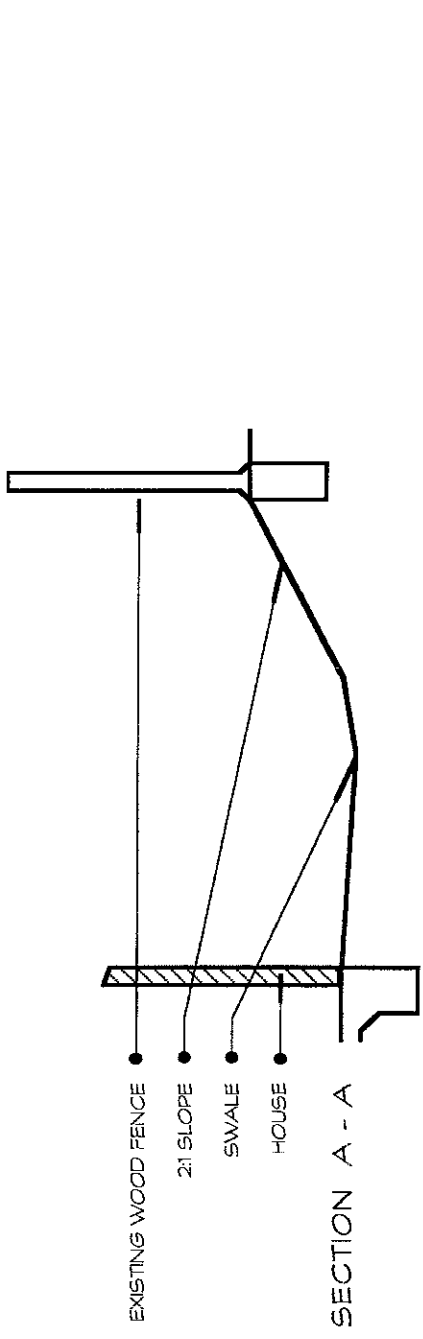

SECTION A - A

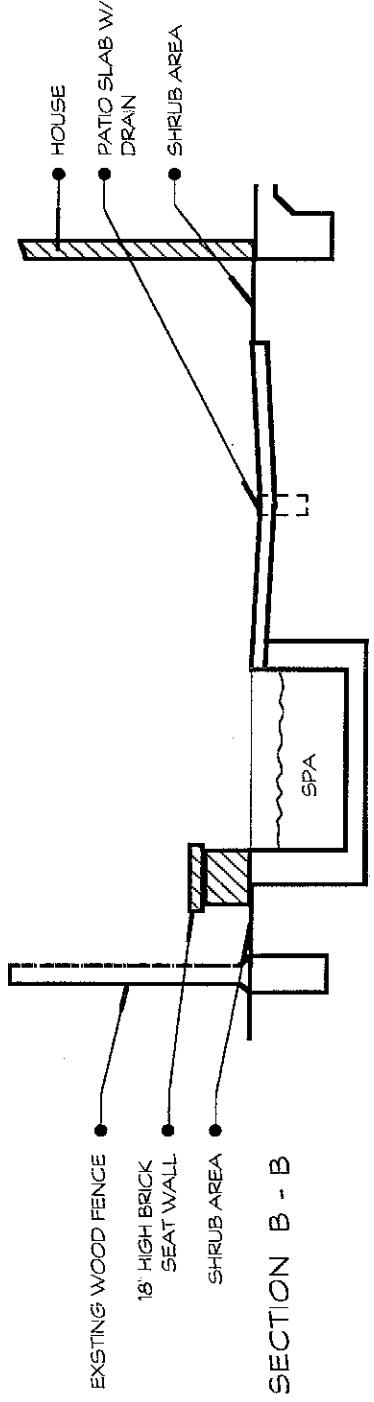

SECTION B - B

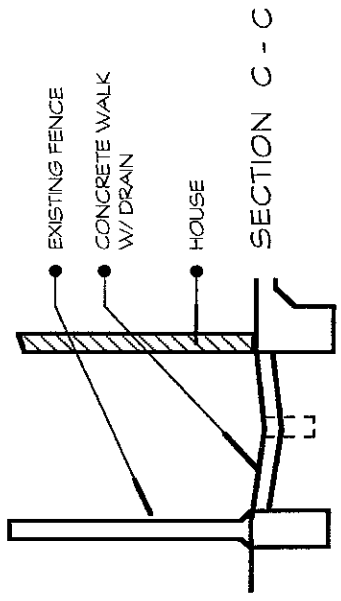

SECTION C - C

**TYPICAL SECTION**  
NOT TO SCALE

Exhibit E

**KEYSTONE PACIFIC PROPERTY MANAGEMENT, INC.**  
**ARCHITECTURAL APPLICATION PROCESSING DESK**

**PURPOSES:** (1) To take receipt of applications and plans, log them into the system and send them to the appropriate architectural committee for review; (2) To answer general questions from homeowners such as what to submit, how many copies are needed, if fees are required, etc.; and (3) To log and send approvals/denials/incomplete applications back to homeowners.

**SETS OF PLANS REQUIRED:** Refer to Architectural Guidelines/Application

**ARCHITECTURAL APPLICATIONS/GUIDELINES:**

1. Architectural Applications may be distributed to and or received from contractors; however applications must be completed and signed by homeowners.
2. When Architectural Applications are requested, the homeowner will be sent a copy of the application. Architectural Standards/Guidelines will only be sent upon request.
3. All plans will be accepted via mail or may be dropped off at the front desk. If mailed, all deadlines for approval will run from the date that the plans are received.
4. All applications and plans are processed through the Architectural Desk.
5. It is Each Owner's responsibility to obtain a receipt at the time that plans are delivered.
6. Any application missing information is considered incomplete, and will be sent back to the homeowner. The Architectural Desk will make every effort to ensure that an application is complete, but cannot guarantee that an application will not later be rejected as incomplete. One copy of every application and submitted set of plans will be kept for the Association's file.
7. It is each Applicant's responsibility to specifically call out all improvements that the Applicant seeks to gain approval for. Improvements which are omitted cannot be approved. Improvements which are not described with specificity may result in later disputes and potentially the removal or relocation of the ambiguous improvement. Thus it is in the best interests of all Applicants to ensure a thorough and detailed preparation of any architectural plans submitted for approval.
8. It is each Owner's responsibility to accurately depict all property lines and easements associated with their property. The Association's Architectural Review Committee does not have the authority to authorize construction upon common area or on easements.
9. Applicant should rely solely upon written responses to any application and should not rely upon any oral representations or opinions expressed by management personnel.

**REVIEW FEES AND/OR DEPOSITS:**

1. All checks submitted for review fees and/or deposits will be promptly processed.
2. Deposit checks will not be held. The purpose of a deposit is threefold. The first reason is to protect the Association against any damages which could occur to the common area during construction. The second reason is to procure timely installation of approved architectural improvements. The third reason is to ensure appropriate compliance with the architectural process.
3. Any application submitted without a required review fee and/or deposit will be returned to the homeowner as incomplete.

4. Refund checks will be issued upon receipt of Notice of Completion and verification by the Architectural Committee that work has been completed in accordance with approved plans.

**NEIGHBOR AWARENESS STATEMENTS/SIGNATURES:**

1. *Front Yard Improvements* – Neighbors to the right, left and front must sign the neighbor awareness form for all submitted front yard improvements. If more than one neighbor directly faces a home, then both must sign a neighbor awareness form.
2. *Rear Yard Improvements* - Neighbors to the right, left and rear of the home must sign the neighbor awareness form for all submitted rear yard improvements. Generally speaking, all neighbors that are adjacent to or which are facing the rear yard perimeter wall must sign a neighbor awareness form.
3. If a neighbor is unwilling to sign the form or if they are difficult to contact, the Applicant must mail a copy of the application to the neighbor by certified mail with a letter that advises the neighbor that they may review their plans if they would like. Their letter should set forth a reasonable deadline for the neighbor to respond by and let the neighbor know to contact management via written correspondence with any concerns they may have. The Applicant does not need to send a copy of their actual plans, but need only advise the neighbor that they are able to review them. The Applicant may send a copy of the certified return receipt with their Architectural Application, or, if they receive the certified mail back unopened/undeliverable, they should attach the original. Also, the homeowner must attach a copy of the letter sent to the neighbor.
4. If the homeowner has a neighbor who hasn't moved in yet, the home is vacant, or they are on a corner lot, they must indicate this on their neighbor awareness form and note the address.
5. Approval of an architectural application is not dependant upon any neighbor approving the project, but a diligent effort should be made to make sure that each neighbors concerns and comments are considered in the architectural process.

**PLANS PROCESSED:**

1. Once the Architectural Desk determines that a homeowner has submitted a complete application and plans, the application will be sent to the Architectural Committee for review.
2. One copy of the application and plans will be kept for the file in the event that the originals are lost.

**STATUS OF REVIEW BY THE ARCHITECTURAL COMMITTEE:**

1. All correspondence relating to Architectural Applications (approval, denial, incomplete) will be sent to homeowners ONLY.
2. All calls requesting status of review will be returned to homeowners only. Contractors may not call for status.
3. Homeowners are encouraged to wait for their application by mail. Once the Architectural Desk receives information from a committee, it is immediately processed and mailed the next business day. If you wish to have a phone call when the committee returns your information to management, please note this on your application. The more time spent returning phone calls that are requesting status of applications means that less time is spent actually processing mail.
4. Applications are processed as they are received. Rush orders can be requested; however it is up to the Architectural Committee to prioritize their workload. Keystone Pacific is

simply responsible for processing applications, but it has no control over expediting rush requests.

5. If you receive your application back indicating that there is missing information, please review the notes or explanation letter and address each item that the Architectural Committee and/or management has noted.
6. Once you make any necessary changes or additions, you must resubmit the number of plans required by the Architectural Guidelines with your application again. A typical architectural modification may require three (3) or more sets of plans.
7. Keystone Pacific is not permitted to give out phone numbers or names of Architectural Committee members or Architects hired to act on behalf of the Committee.
8. Questions relating to what the Architectural Committee is asking for may be directed to the Architectural Desk, who will answer your questions to the best of their ability.

**NOTICE OF COMPLETIONS:**

1. Once an Applicant submits their Notice of Completion, the Architectural Desk will pull the file and send it to the Architectural Committee for review.
2. When the Notice of Completion is approved, the Architectural Desk will pull the original copy of the deposit check and turn it into Accounts Payable to process for a refund with the Association's monthly check run. A copy of the approved Notice of Completion will also be attached to the information turned into Accounts Payable, which will be returned to the homeowner with their refund.
3. If a homeowner insists that their deposit be returned prior to the regular monthly check run, \$15.00 will be taken out of their deposit as a fee. Even in the event of a rush, there may be at least a one to two week turn around time in order to obtain the two necessary signatures from the Board. Management does not have the authority to sign refund checks.
4. If a Notice of Completion is not approved, a copy will be returned to the Applicant and the manager will be given a copy. The homeowner is responsible for making any necessary changes and resubmitting the Notice of Completion for review until it is finalized and approved.

**PAINTING:**

1. Unless the Association has paint color codes adopted as part of the Architectural Guidelines, management does not have this information. Any painting of the exterior of a home, even if it is intended that the same color is being applied. Requires that the architectural application process be followed. Each Applicant is responsible for ensuring that the paint actually used matches the color that is approved. The homeowner is responsible to insure that the paint color does not give off hues of different colors in different light. If the Association does have written color codes as a policy, the information shall be sent to homeowners in writing, via e-mail, fax or regular mail. Managers are not permitted to give this information out over the phone as the room for error is too great.
2. The Architectural Desk and managers are not responsible for answering questions specifically related to interpreting what is found in the Architectural Guidelines, pertaining to what hours contractors may work, or pertaining to what improvements are likely to be approved, allowed or not allowed.

## **Keystone Pacific's Architectural Desk Architectural Processes Q&A**

### **Definitions**

“Architectural Guidelines” – Otherwise referred to as Architectural Standards, Design Review Guidelines, Design Guidelines, Design Standards or any other document containing the parameters in which a homeowner is to follow when submitting an application.

“Reviewer” – Otherwise known as the person or persons responsible for reviewing the plans, such as a homeowner committee, Board of Directors or a qualified third party consultant hired to perform the review on behalf of the committee.

### **Facts**

The staff members working the architectural desk for Keystone Pacific **process** anywhere from 50 to 100+ plan submittals a day.

Keystone Pacific staff members **do not** review plans.

The staff members working the architectural desk for Keystone Pacific only make sure the application has been completed and submitted with your plans, a review fee/deposit check has been submitted (if applicable) and the correct number of plans have been submitted. This information is then forwarded to the party responsible for reviewing plans on behalf of the association.

### **Plan Review**

Who is responsible to review your plans?

Your association CC&R's contain a section devoted to architectural review, which indicates how many members need to be appointed to a committee and/or whether or not this task can be delegated to a third party consultant. Some CC&R's give the committee the right to delegate this task to a qualified third party consultant.

Who makes the final decision on approval or denial?

The designated party responsible for reviewing plans.

How do I find out how much time the committee has to review my plans?

Your CC&R's will provide this information and/or the architectural guidelines. Review periods vary from 30 to 90+ days. This means the committee and/or third party consultant can take up to that many days to review your plans. Sometimes it doesn't take that long, but nothing can be guaranteed.

Keystone Pacific has no jurisdiction over the committee members or the third party consultant. The committee is appointed by the Board of Directors and works at the pleasure of the Board and the third party consultant is retained by the Board of Directors on behalf of the association.

What if my plans are denied – do I have to wait another 30-90+ days for review?

Yes, each time a plan is resubmitted the time frame allowed for the review process starts over.

Why can't you “rush” the review upon request?

Keystone Pacific has no jurisdiction over the time constraints of the committee and/or third party consultant. As a courtesy, we can include a note requesting the appropriate party to “rush” the plan review, but we cannot guarantee this will occur.

Can't I pay for a “rush” review?

This policy would need to be adopted by the Board of Directors and could only realistically be implemented if a third party consultant were being employed. This concept would not be feasible with a volunteer homeowner committee.

What do I do if the plans are not back yet and the time period for review is past?

Place a call to Keystone Pacific's architectural desk at (949) 838-3239 or e-mail [architectural@keystonepacific.com](mailto:architectural@keystonepacific.com) to request information. Some CC&R's require the request be made in writing and then allows the committee 15 or more days to respond before your plans are deemed approved.

Why can't I contact the reviewer directly with my questions?

The third party consultant would be inundated with calls, thus taking away from their limited time to actually perform reviews in a timely manner. Homeowner committee members are volunteers and therefore their personal information cannot be provided. All questions can be submitted in writing and will be forwarded to the appropriate party and a response will be provided in writing.

Who pays for the qualified consultant to review the plans?

The association pays for this service. If a third party consultant is contracted to review plans on behalf of the association, the fees are paid via your submittal fee. The CC&R's typically give the association the right to collect fees in order to offset the costs related to plan review costs when a third party consultant is utilized.

Why can't Keystone Pacific give me approval?

Keystone Pacific is an independent third party managing agent and has no authority to review, approve or deny plans on behalf of any association. The only responsibility of Keystone Pacific is to make sure the application has been completed and submitted with your plans, a review fee/deposit check has been submitted (if applicable) and the correct number of plans have been submitted. This information is then forwarded to the party responsible for reviewing plans on behalf of the association. Keystone Pacific also takes receipt of the plans from either the committee and/or third party consultant and then notifies the homeowner of the decision.

Why can't KPPM give me the decision over the phone?

A plan review usually results in many comments from the reviewing party. In order to avoid any miscommunication, Keystone Pacific has a policy that all decisions made by either the committee and/or third party consultant must be communicated in writing.

Can I pick my plans up?

If you would like to pick your plans up, you need to notify the staff members at the architectural desk and every effort will be made to accommodate this request.

Why can't my contractor call and get the information or pick up my plans for me?

Unless the homeowner provides written authorization for a specific person to receive information on their behalf, Keystone Pacific can only communicate with the homeowner. All decisions must be mailed to the homeowner's mailing address on file.

Why can't KPPM give me interpretation of the guidelines or at least give me a general idea of whether my idea will be approved?

The details on any given set of architectural guidelines cannot possibly be known by the one person answering the phone at the architectural desk. Keystone Pacific would be guessing if they tried to assist someone in answering questions about the guidelines. As a homeowner, you need to consult with the professional assisting you with your plans regarding any questions you have pertaining to the guidelines.

If I want to make changes to my approved plan, do I have to re-submit?

Yes, any plan changes need to be submitted for approval.

If I am just painting my house the same colors, do I have to submit for review?

The safest bet is to submit. Many association documents require submittal regardless of whether or not the existing paint color is being used. Some documents do not require an architectural application to be submitted to repaint the existing color, however, you should refer to your architectural guidelines for the answer to this question or contact your community association manager.



Why are site photos sometimes required?

Depending on the complexity of the improvements, the committee and/or third party consultant needs a point of reference when visualizing the project you are proposing.

### **Neighbor Awareness**

What does a Neighbor Awareness form do for you?

A Neighbor Awareness form is merely a means of notifying your neighbors that you plan to make exterior modifications to your home. Your neighbor does not have the right to approve or deny proposed modifications to your home, but they do have the right to be aware and make comments for the reviewing party to consider. The committee and/or third party consultant is required to approve your plans if they meet the architectural guidelines.

Why use a Neighbor Awareness form if it doesn't influence the review?

Some associations utilize this form, as it is believed it keeps people informed. Some think it allows the owner the opportunity to modify proposed changes if their neighbor has a concern. There are several associations that do not require a Neighbor Awareness form. You need to check your architectural guidelines and/or architectural application to determine whether or not your association requires this form.

How many signatures are required on the Neighbor Awareness Form?

If you are on a single loaded street, meaning you have no neighbors across the street from you, then you only need your neighbors to the left, right and behind you. If you are on a double loaded street, meaning you have neighbors across the street, you need your neighbors to the left, right, behind you and across from you. Any property that touches your property should be signing your form. NOTE: Some associations also require signatures on the actual plans.

What would happen if I just leave a signature off the form or have a neighbor sign a few doors down, versus my immediate neighbors?

Leaving a signature off the form could also delay your submittal process, because if you don't provide the required signatures, your submittal may be deemed incomplete and will be returned to you. Additionally, leaving a signature off the form or getting a distant neighbor to sign may void your plan approval if later challenged.

What if my neighbor is a renter?

You may indicate this on the form and you should also mail a letter via certified mail to the address anyway notifying the owner of the property of your intentions to submit for exterior modifications. Provide a copy of the letter and returned receipt with your application.

### **After You Are Done With Improvements**

What do I need to do after my improvements are finished?

When complete, fill out the notice of completion form and attach photos of the improvements from all angles. You can e-mail these photos to [architectural@keystonepacific.com](mailto:architectural@keystonepacific.com) or mail a hard copy. Keep in mind that the photos should show set back requirements met (use a tape measure in your photo) and needs to show the overview of the improvements. The committee and/or third party consultant will take these photos and compare them to your plans to make sure all was installed per plan.

Where do I get the notice of completion form?

If your Association has a website, it will be under the architectural section or forms section. If not, e-mail [architectural@keystonepacific.com](mailto:architectural@keystonepacific.com) and request one be e-mailed to you. If no e-mail, call (949) 838-3239 and ask that one be mailed to you, or provide a fax number in which it can be sent.

How difficult is it to get my notice of completion signed off?

If you installed per plan and provide pictures of all improvements it is very easy. If you didn't install a tree that was on your plan, expect to be told to install it – in the size and species you put on your plans. Anything that wasn't installed per plan will hold up your notice of completion approval.

Can a site visit be performed in place of a notice of completion?

Site visits could be performed in place of a photo notice of completion review only if you are willing to pay, in advance, the cost for the third party consultant to perform the review. If your review is performed by a homeowner committee, you could request this; however it would be up to the committee/board to do this and most likely this would not happen due to the time involved.

What if my notice of completion keeps getting denied, what do I do?

The best thing to do is to do everything on the list of issues pointed out to you. If you feel you have completed those items, then you should address your concerns with the Board. If you have no plans to complete all of the items on the list, then you should resubmit your plans showing only what you actually installed. The Board of Directors does have the right to call you to a hearing and assess fines if you choose to ignore the notification to correct items. Most CC&R's give homeowners 30 days to correct issues. After this, the Board can move forward with hearings and fines.

How soon can I get my deposit back once my notice of completion is approved?

Associations cut checks once a month. If you happened to obtain approval for your notice of completion right after a check run was issued, you would have to wait until the following month, which could take up to 45 days.

### **Variations/Appeals**

What if I do not agree with the reviewer's decision?

You may fill out a variance/appeal form that will go to your Board of Directors for review and consideration, if the governing documents of the association allow for this. Some documents do not and the final authority lies with the committee. There is sometimes a fee required for these requests when a third party consultant is being utilized, which must be paid to the Association prior to the work being performed.