

**EBAC MODEL CS60  
INDUSTRIAL DEHUMIDIFIER  
OWNER'S MANUAL**

## INTRODUCTION

Designed for a wide range of applications, the CS60 dehumidifier is a rugged, industrial unit which utilizes an energy-efficient compressor and a compact portable design to provide easy efficient drying.

The CS60 has a number of special features:

- Compact Size
- High efficiency rotary compressor
- Ebac's "**Hot Gas**" defrost system
- Exterior epoxy powder-coated finish
- Provision for permanent drainage
- All galvanized interior
- Extra long power cord
- Humidistat

The fan draws the moist air through the cold evaporator coil, which cools the air below its dew point. Moisture forms on the evaporator coil and is collected in the condensate tray, which is equipped with a permanent drain. The cooled air then passes through the hot condenser coil where it is reheated using the same energy removed during the cooling phase, plus the additional heat generated by the compressor. The air is, therefore, discharged from the dehumidifier at a slightly higher temperature with a lower absolute humidity than that which entered. Continuous circulation of air through the dehumidifier gradually reduces the relative humidity within the area.

The CS60 dehumidifier is a rugged, reliable drying unit designed to operate effectively over a broad range of temperature and humidity conditions. An active hot gas defrost system, controlled by an electronic timer, guarantees positive de-icing, thereby optimizing operation at low temperatures.

The unit incorporates a welded and galvanized steel chassis and is finished in an epoxy coating for resilience to damage caused by rough handling.

## SPECIFICATIONS

<b>MODEL:</b>	CS60
<b>HEIGHT:</b>	13.25" (336.55mm)
<b>WIDTH:</b>	13.75" (349.25mm)
<b>DEPTH:</b>	20.25 " (514.35mm)
<b>WEIGHT:</b>	62.83lbs (28.5 kg)
<b>AIRFLOW:</b>	360 CFM
<b>EXTRACTION:</b>	56 Pints Per Day At 80°F/60% RH
<b>POWER SUPPLY:</b>	115V/ 60Hz/ 1 ph
<b>FINISH:</b>	Powder-coated Epoxy
<b>OPERATING RANGE:</b>	33°F – 105°F
<b>REFRIGERANT:</b>	R-22 (13 oz)

## OPERATION

The following procedures should be followed to test the CS60 for correct operation:

1. After unpacking, examine all external features to confirm damage-free shipment. Report all defects and damage at once. Connect the power cable to a grounded 15 Amp electrical outlet.
2. Check dehumidification process as follows:

<b>CAUTION: DO NOT REMOVE COVERS WHEN UNIT IS IN OPERATION.</b>
---

- A. Place unit on a level surface.
- B. Start up unit by turning the humidistat control knob until the unit turns on.
- C. Check that the compressor is running.
- D. Leave the machine running for 15 minutes.
- E. Observe the evaporator coils through the rear upper grill, to confirm frost operation.
  - i. If the air temperature is below 80° F, an even coating of frost should cover the entire evaporator coil
  - ii. If the air temperature is above 80° F, frost and/or droplets of condensed water should cover the entire evaporator coil.
- F. After continuous running time of approximately 55 minutes, the unit will enter “Hot Gas” defrost mode for 5 minutes and then automatically return to normal operation.

If, after carrying out the above procedures, the unit does not appear to function properly, refer to the *Trouble Shooting* section, which follows, or contact the Factory Service Center.

<b>CAUTION: Once the unit has been switched off, wait at least five minutes before restarting.</b>
--

## ROUTINE MAINTENANCE

**WARNING:** ENSURE THAT THE POWER CORD TO THE MACHINE HAS BEEN DISCONNECTED BEFORE CARRYING OUT ROUTINE MAINTENANCE.

To ensure continued full efficiency of the dehumidifier, maintenance procedures should be performed as follows:

1. Clean the surface of the evaporator and condenser coils by blowing the dirt out from behind the fins with compressed air. Hold the nozzle of the air hose away from the coil to avoid damaging the fins. Alternatively, vacuum clean the coils.

**WARNING:** DO NOT STEAM CLEAN REFRIGERATION COILS.

2. Check that the fan is firmly secured to the motor shaft and that the fan rotates freely. **The fan motor is sealed for life and therefore does not need oiling.**
3. To check the refrigerant charge, run the unit for 15 minutes and briefly remove the top cover. The evaporator coil should be evenly frost coated across its surface. At temperatures above 80°F, the coil may be covered with droplets of water rather than frost. Partial frosting accompanied by frosting of the thin capillary tubes, indicates loss of refrigerant gas or low charge.
4. Check all wiring connections.
5. To check the operation of the defrost system, switch the machine on and leave it running for approximately 55 minutes. The machine will then enter “Hot Gas” defrost mode for approximately 5 minutes before returning to normal operation. If the unit will not defrost, the printed circuit timer board may be defective or the by-pass valve may be inoperable.

**IF ANY OF THE PRECEDING PROBLEMS OCCUR, CONTACT THE EBAC SERVICE CENTER PRIOR TO CONTINUED OPERATION OF THE UNIT TO PREVENT PERMANENT DAMAGE.**

## REPAIRS

1. Should an electrical component fail, consult the Factory Service Center to obtain the proper replacement part.
2. If refrigerant gas is lost from the machine, it will be necessary to use a refrigeration technician to correct the fault. Contact the Factory Service Center prior to initiating this action.

Any competent refrigeration technician will be able to service the equipment. The following procedure must be used:

- a. The source of the leak must be determined and corrected.
- b. The machine should be thoroughly evacuated before recharging.
- c. The unit must be recharged with refrigerant measured accurately by weight.
- d. For evacuation and recharging of the machine, use the crimped and brazed charging stub attached to the side of the refrigerant compressor.

The charging stub should be crimped and rebrazed after servicing. **NEVER** allow permanent service valves to be fitted to any part of the circuit. Service valves may leak causing further loss of refrigerant gas.

3. The refrigerant compressor fitted to the dehumidifier is a durable unit that should give many years of service. Compressor failure can result from the machine losing its refrigerant gas. The compressor can be replaced by a competent refrigeration technician.

Failure of the compressor can be confirmed by the following procedure:

- a. Establish that power is present at the compressor terminals using a voltmeter.
- b. With the power disconnected, check the continuity of the internal winding by using meter across the compressor terminals. An open circuit indicates that the compressor should be replaced.
- c. Check that the compressor is not grounded by establishing that a circuit does not exist between the compressor terminals and the shell of the compressor.

## TROUBLESHOOTING

<u>SYMPTOM</u>	<u>CAUSE</u>	<u>REMEDY</u>
<b>Unit inoperative</b>	1. No power to unit	1. Check the power from power supply panel
<b>Little or no airflow</b>	1. Loose fan on shaft 2. Fan motor burnt out 3. Dirty refrigeration coils 4. Loose electrical wiring  5. Fuse blown or circuit breaker tripped	1. Tighten fan 2. Replace the fan motor 3. See <i>Routine Maintenance</i> Section 4. Check the wiring diagram to find fault and repair 5. Replace the fuse or reset the circuit breaker
<b>Little or no water extraction</b>	1. Insufficient air flow 2. Compressor fault 3. Loss of refrigerant gas	1. Check all of the above 2. Contact the Factory Service Center 3. Contact the Factory Service Center
<b>Little or no defrost when required</b>	1. Faulty timer 2. Faulty by-pass valve	1. Contact the Factory Service Center 2. Contact the Factory Service Center
<b>Unit vibrates excessively</b>	1. Loose compressor 2. Damaged fan	1. Tighten the nuts on the compressor mounts 2. Replace fan
<b>Water flooding inside the machine</b>	1. Drain pipe blocked/frozen 2. Drain pipe too high  3. Crimped or blocked tubing	1. Clear the obstruction 2. Ensure that no section of the drain hose is above the level of the water outlet 3. Straighten, clear, or replace tubing

Sales Inquiries: 800-934-9194

## CS 60 SPARE PARTS LIST

<u>NUMBER</u>	<u>DESCRIPTION</u>	<u>PART NUMBER</u>	<u>QUANTITY</u>
1	Defrost Timer	1600550	1
2	Control Knob	2019708	1
3	Capillary Tube	3014251	48"
4	Solenoid Valve	3020814	1
5	Filter Dryer	3020901	1
6	Compressor	3022163	1
7	Solenoid Coil	3030421	1
8	Capacitor	3030908	1
9	Humidistat	3035145	1
10	Mains Lead	3035148	1
11	Fan Motor	3035788	1
12	Relay	3036157	1
13	Axial Fan	3040129	1
14	Fan Inlet Ring	3040326	1
15	Rubber Foot	3101436	1
16	Drain Tubing	3014338	9 Feet
17	Drain Tube Jubilee Clip	3086101	1
18	Condenser Coil	2026014	1
19	Evaporator Coil	2026013	1





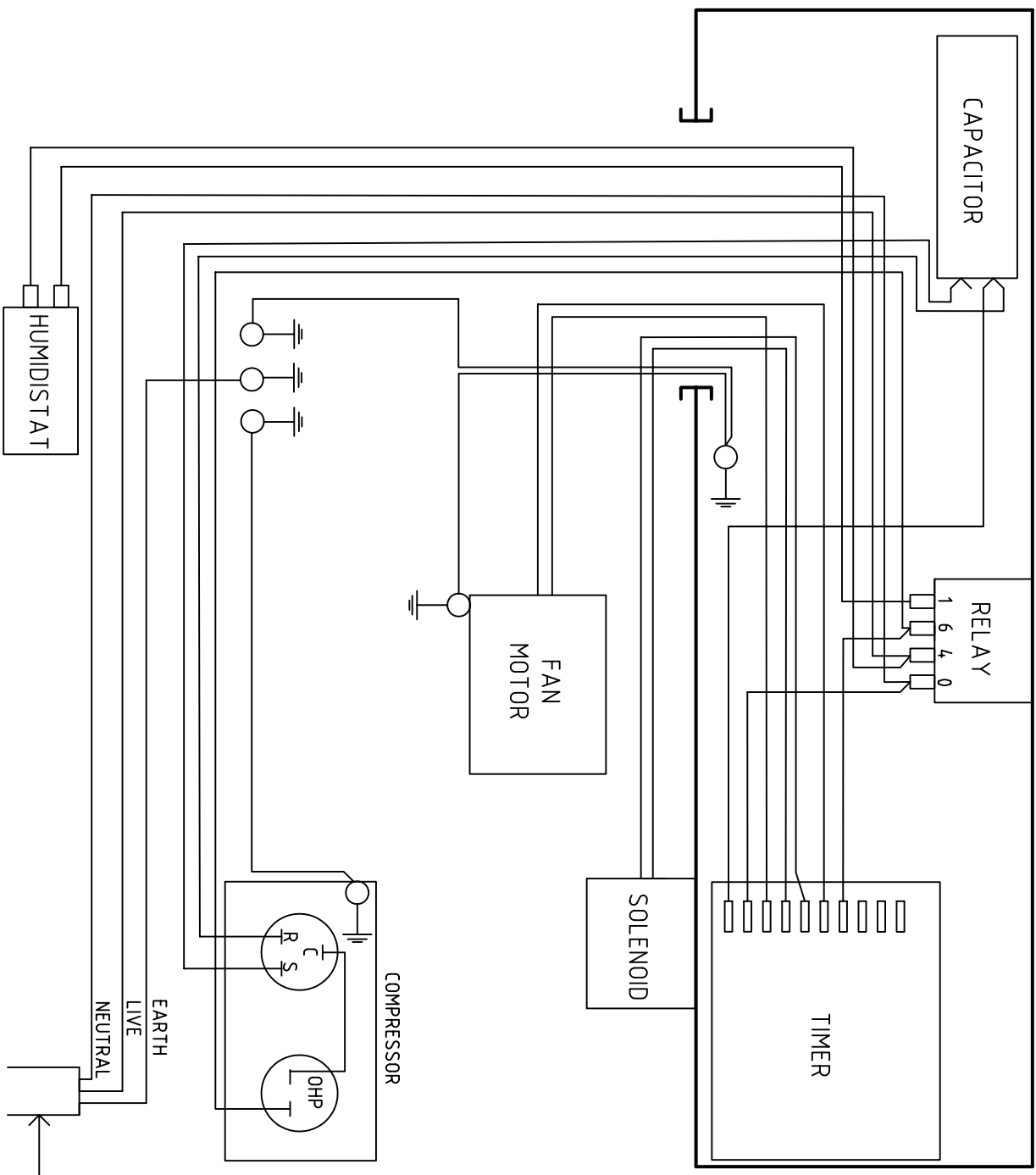

ISSUE	DATE	AMENDMENTS
1	24/06/04	ORIGINAL

PIGGYBACK FASTONS ON RELAY 4 & 6  
TO BE UPSIDE DOWN

**TITLE**  
CS60 WIRING DIAGRAM

**MATERIAL**

**FINISH**

**DRAWN:** C LILLY

**CAD SCALE:**

**DRG. NO.:** 5010283

**3RD ANGLE PROJECTION**  
DO NOT SCALE  
IF IN DOUBT ASK

**DIMENSIONS:** IN, m, m.  
TOLERANCES UNLESS  
OTHERWISE STATED

0.0 ± 1  
0.0 ± 0.25  
ANGULAR ± 0.05  
ANGULAR ± 0.5 DEGREE

**SHEET**  
1 OF 1

**SHEET**  
1 OF 1

ISSUE	DATE	AMENDMENTS
1	08/07/04	ORIGINAL

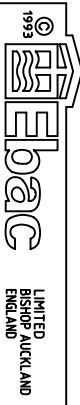
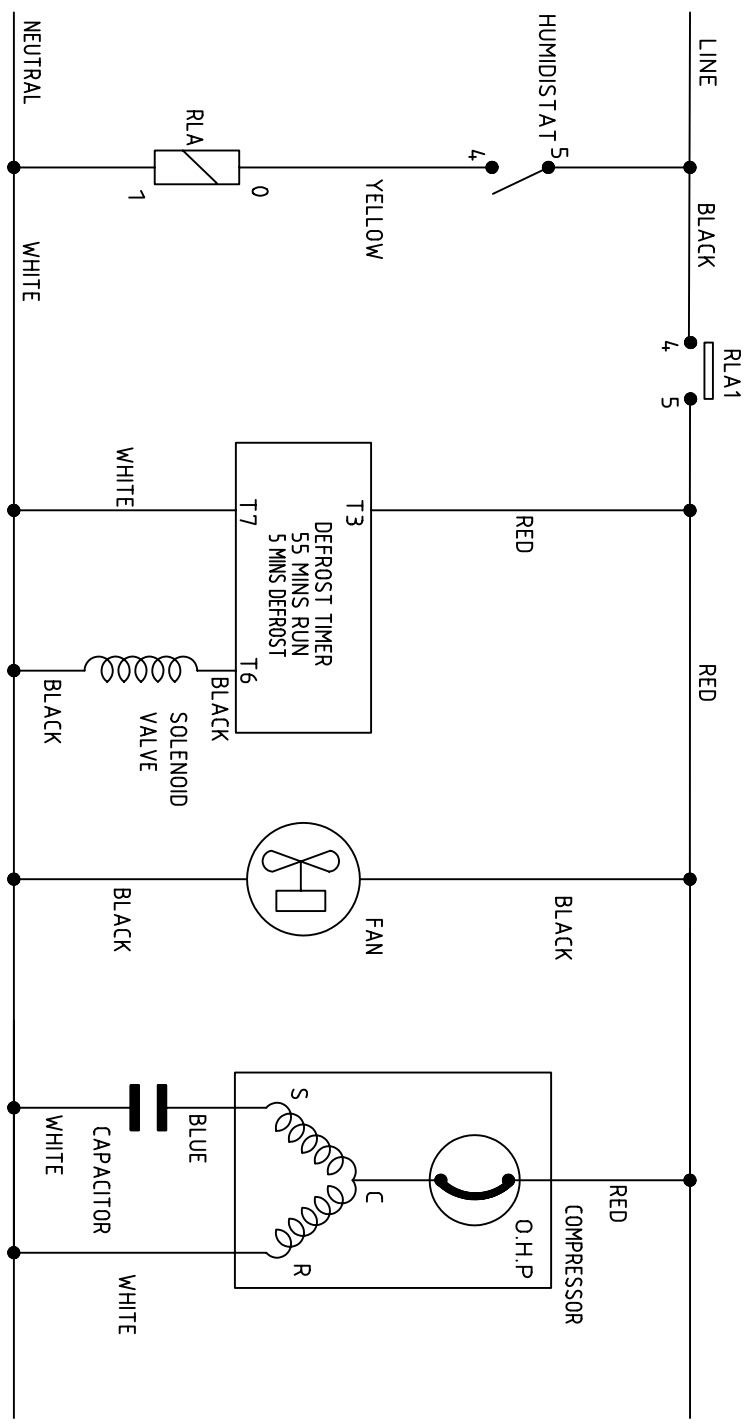

TITLE  
CS60 SCHEMATIC

3RD ANGLE PROJECTION  
DO NOT SCALE  
IF IN DOUBT ASK

DIMENSIONS IN IN. OR M.M.  
TOLERANCES UNLESS OTHERWISE STATED  
0.0 ± 1  
0.0 ± 0.25  
ANGULAR ± 0.5 DEGREE

MATERIAL	DRAWN: C LILLY	SHEET
FINISH	CAD SCALE:	1 OF 1
	DRG. NO. 5020252	

ISS.	DATE	COMMENTS
1	12/07/04	ORIGINAL

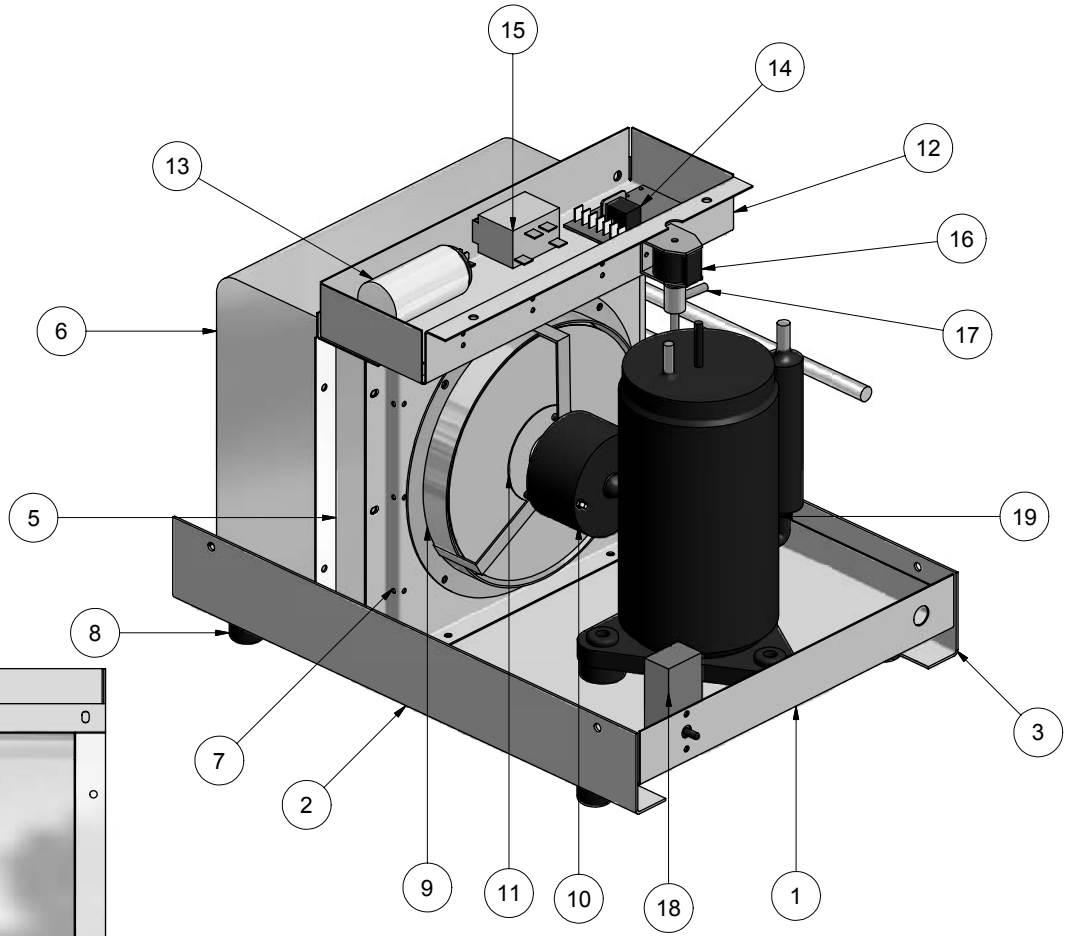
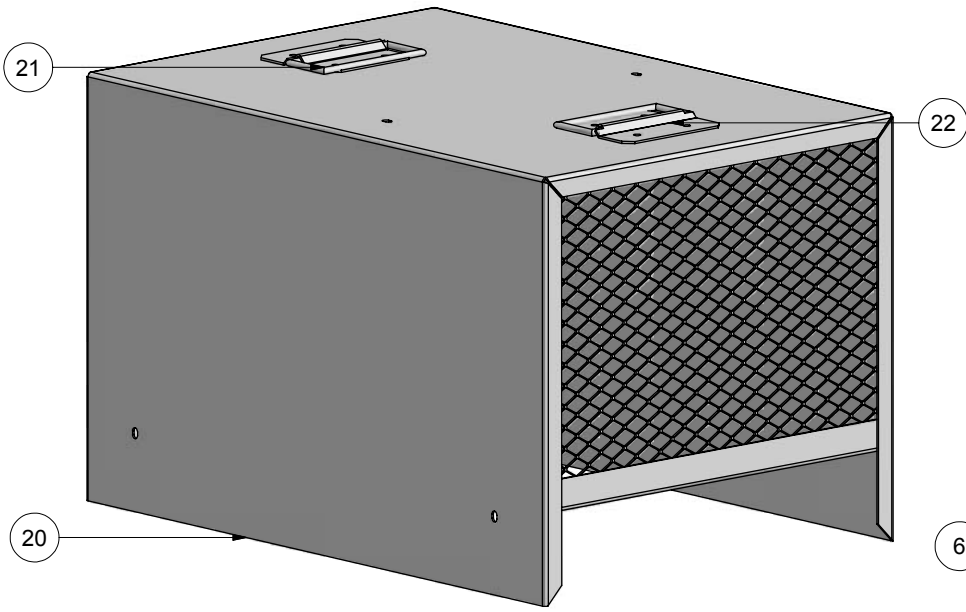

Parts List		
ITEM	QTY	DESCRIPTION
1	1	Base
2	1	Left Base Support
3	1	Right Base Support
4	1	Drain Pipe
5	1	Condenser
6	1	Evaporator Coil
7	1	Fan Housing
8	4	Rubber Foot
9	1	Fan Inlet Ring
10	1	Fan Motor
11	1	Fan Blade
12	1	Electrical Box
13	1	Capacitor
14	1	Timer
15	1	Relay
16	1	Solenoid Coil
17	1	Solenoid Valve
18	1	Humidistat
19	1	Compressor
20	1	Cover
21	1	Handle
22	1	Handle Support

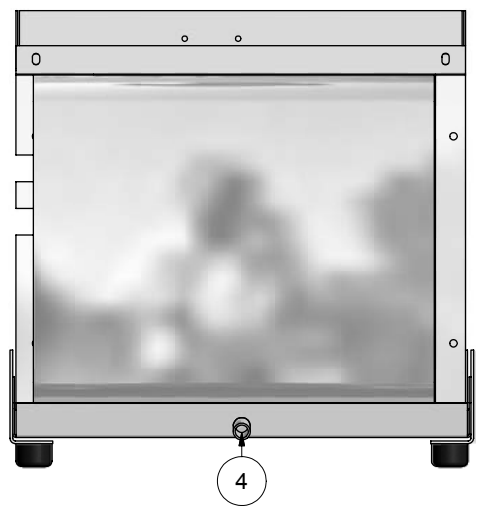

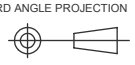
 LIMITED BISHOP AUCKLAND ENGLAND	TITLE <b>CS60 GENERAL ASSEMBLY</b>	
	MATERIAL <b>VARIOUS</b>	DRAWN : <b>C LILLY</b>
3RD ANGLE PROJECTION  DO NOT SCALE IF IN DOUBT ASK	DIMENSIONS IN m.m. TOLERANCES UNLESS OTHERWISE STATED 0. ± 1 0.0 ± 0.25 0.00 ± 0.05 ANGULAR ± 0.5 DEGREE	CAD SCALE : <b>1/4</b> DRG.NO. <b>10264CS-US</b>
FINISH		SHEET 1 OF 1