



Leica TPS1200 RoadRunner Tunnel Technical Reference Manual

Version 3.1
English

- when it has to be **right**

Leica
Geosystems

Introduction

Purchase

Congratulations on the purchase of a RoadRunner Tunnel application.



To use the product in a permitted manner, please refer to the detailed safety directions in the User Manual.

Product identification

The type and serial number of your product are indicated on the type plate. Enter the type and serial number in your manual and always refer to this information when you need to contact your agency or Leica Geosystems authorized service workshop.

Type: _____

Serial No.: _____

Symbols

The symbols used in this manual have the following meanings:

Type	Description
	Important paragraphs which must be adhered to in practice as they enable the product to be used in a technically correct and efficient manner.

Trademarks

- Windows and Windows CE are a registered trademark of Microsoft Corporation
 - CompactFlash and CF are trademarks of SanDisk Corporation
 - Bluetooth is a registered trademark of Bluetooth SIG, Inc
- All other trademarks are the property of their respective owners.

Table of Contents

In this manual

Chapter		Page
1	Introduction	6
1.1	Overview	6
1.2	Basic Terms	8
1.3	Elements for Tunnel Stake Out and Check Measurements	11
1.3.1	Tunnel Face	11
1.3.2	Tunnel Profiles	13
1.4	Shifts	17
1.4.1	Centre Line Shifts	18
1.4.2	Design Profile Shifts	20
2	Getting Started	22
2.1	Preparing Design Data	22
2.1.1	Tunnel Centreline	23
2.1.2	Design Profiles	24
2.1.3	Data transfer to sensor	27
2.2	Using the On-Board Application	28
2.2.1	Selecting the Application	29
2.2.2	RoadRunner Begin	30
2.2.3	RoadRunner Setup	32
3	Checking and Measuring the Tunnel	34
3.1	Overview	34
3.2	Checking Profiles	35
3.2.1	Working in Standard mode	35
3.2.2	Working in Advanced mode	37

	3.2.3	Checking the Profile	38
3.3		Scanning Profiles	42
	3.3.1	Working in Standard mode	42
	3.3.2	Working in Advanced mode	44
	3.3.3	Defining Profiles to Scan	45
	3.3.4	Scan Limits	48
	3.3.5	Defining Discrete Points to Measure	52
	3.3.6	Making a Scan	53
4		Setting Out the Tunnel	58
<hr/>			
	4.1	Overview	58
	4.2	Setting Out the Tunnel Face	59
		4.2.1 Working in Standard mode	63
		4.2.2 Working in Advanced mode	65
		4.2.3 Setting Out the Point	66
	4.3	Setting Out a Tunnel Profile	72
		4.3.1 Working in Standard mode	73
		4.3.2 Working in Advanced mode	75
		4.3.3 Setting Out the Point	76
5		Project and Job Management	84
<hr/>			
	5.1	Overview	84
	5.2	Selecting a Project	87
		5.2.1 Overview	87
		5.2.2 Browse for Existing Project	88
		5.2.3 Resuming the Last Task	89
	5.3	Creating a New Project	90
	5.4	Deleting a Project	92
	5.5	Editing a Project	94

6	Tunnel Job	96
6.1	Overview	96
6.2	Design Data	97
6.2.1	Horizontal and Vertical Alignments	97
6.2.2	Design Profiles	98
6.2.3	Layers	99
6.3	Tasks	100
6.3.1	Creating a New Task	101
6.3.2	Working with Shifts	104
6.4	Viewing and Editing the Design Data	107
6.4.1	Overview	107
6.4.2	Viewing the Design Data	109
6.4.3	Editing the Design Data	114
7	Configuration	116
7.1	Overview	116
7.2	Tunnel Configuration General Page	118
7.3	Tunnel Configuration Check Page	123
7.4	Tunnel Configuration Scan Page	125
7.5	Tunnel Configuration Info and Plot Page	127
7.5.1	Defining the Info Page Display	130
7.6	Tunnel Configuration Logfile Page	134
	Index	136

1

Introduction

1.1

Overview

Description

The RoadRunner Tunnel application is an "add-on" component to the System 1200 RoadRunner application. The tunnel application allows the user to perform tunnel specific survey tasks.

Functionality

The application consists of two main functions:

- **Check Tunnel** for checking a built or excavated tunnel with a tunnel design;
- **Stake Tunnel** for setting out tunnel features during construction.

Check Tunnel

Each function consists of two main tasks, in the case of Check Tunnel, these tasks are:

- **Check Profile** for measuring any point in the tunnel and comparing the measured point with the theoretical design point.
- **Scan Profile** for measuring profiles of the tunnel.

Stake Tunnel

The Stake Tunnel function consists of:

- **Stake Face**, a task that allows setting out at the point of excavation.
- **Stake Profile** for setting out any point of the tunnel at a given chainage.

LandXML data format

The centre line of the tunnel may be imported for use on-board the sensor using the industry standard LandXML data format or in formats exported from a number of other tunnel design packages using the Design to Field component of the Leica Geo Office application.

Refer to chapter "2.1.1 Tunnel Centreline" for more information regarding the import of centre line data.

Tunnel design profiles

Tunnel design profiles may be created using the tunnel profile editor PC application. This application is integrated into the Design to Field component.

Keys

The **ALL (F1)**, **DIST (F2)**, **REC (F3)**, **<PAGE (F5)** and **PAGE> (F6)** keys have the same functionality as throughout the rest of System 1200.

1.2

Basic Terms

Basics introduced

In order to make the following chapters on staking and checking tunnels easier to understand, the basics are introduced in this chapter.

Please be aware that the terminology or workflow used on different construction sites may vary from the one used in this manual, however, basic principles remain the same.

Technical terms

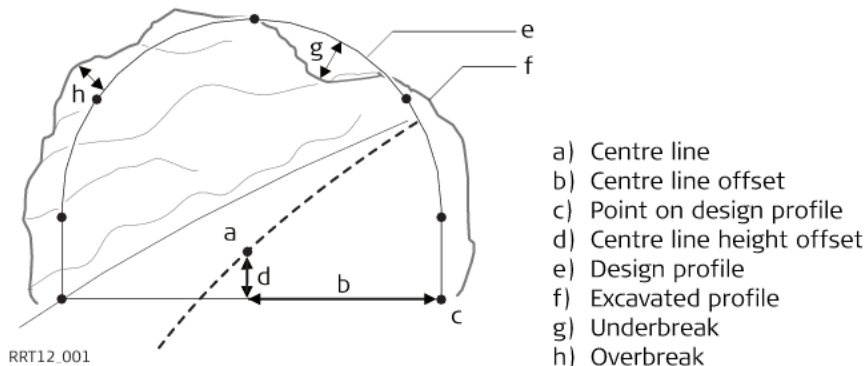

3D View

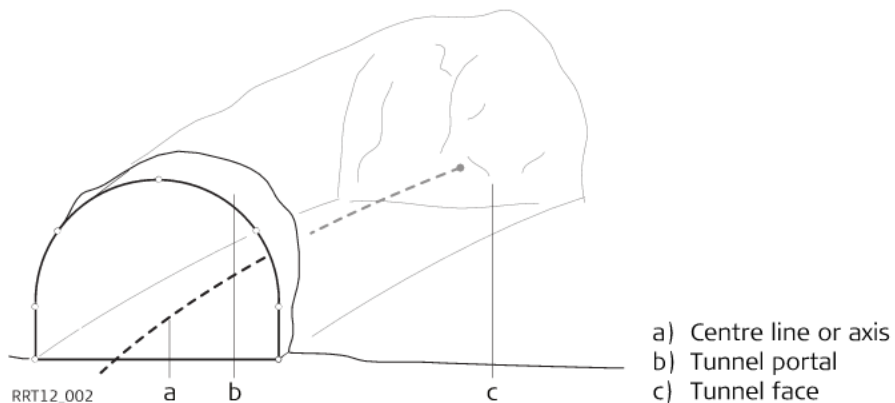

Superelevation

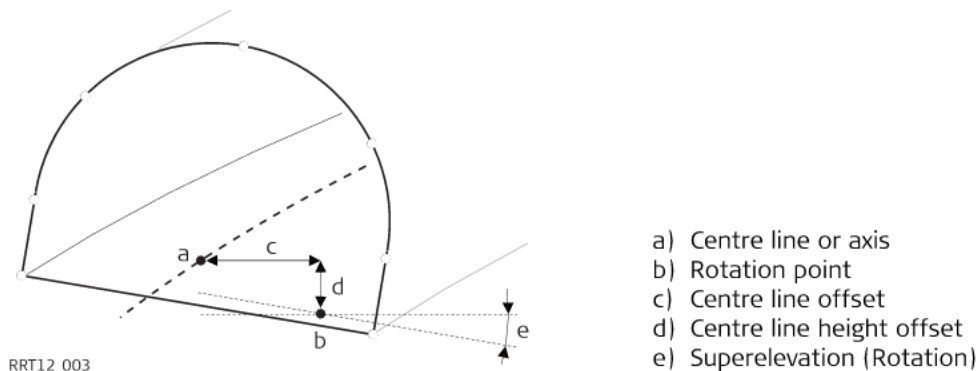

Refer to Chapter 3, RoadRunner Technical Reference manual for additional terms.

Technical Terms

Technical Term	Description
Centre line	Geometric alignment in two or three dimensions to which all design elements of the project are referenced.
Chainage or station	The cumulative distance along the centre line, frequently but not always starting at zero.
Design Profile	Geometric description of the designed shape of the cross-section of the tunnel. The design profile may contain straight or curve elements.
Excavated Profile	Shape of the cross-section of the tunnel that has been excavated.
Underbreak	When the excavated profile is inside the design profile, the underbreak is the perpendicular distance between the design profile and the excavated profile.
Overbreak	When the excavated profile is outside of the design profile, the overbreak is the perpendicular distance between the design profile and the excavated profile.
Tunnel Portal	The open end of a tunnel.
Tunnel Face	The point where the excavated tunnel meets existing terrain.
Superelevation (Rotation)	Angle of rotation of a design profile, used to take into account the velocity of a moving vehicle through a curve.
Rotation Point	The point about which the design profile is rotated. This point may or may not coincide with the centre line.

1.3

Basic stake out and check elements

1.3.1

Staking Tunnel Faces

Horizontal and vertical offsets

Elements for Tunnel Stake Out and Check Measurements

In general there are two different basic stake out and check elements within a tunnel:

- Tunnel Face
- Tunnel Profile

Tunnel Face

It is usually required to stake out the tunnel face to indicate the position to excavate when certain tunnelling methods are used (e.g. Drill and Blast or excavation using a roadheader).

The points to stake on the tunnel face may be defined in various ways:

By horizontal and vertical offsets with respect to the centre line:

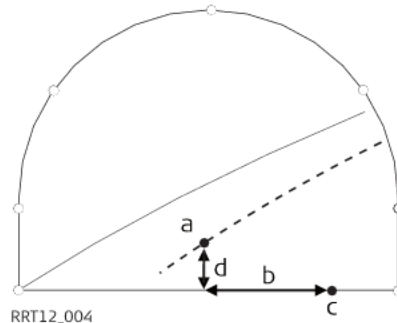

- a) Centre line
- b) Point on tunnel face to stake
- c) Centre line offset
- d) Centre line height offset

Distance along profile

By the distance from the start of the design profile and an offset from the design profile.

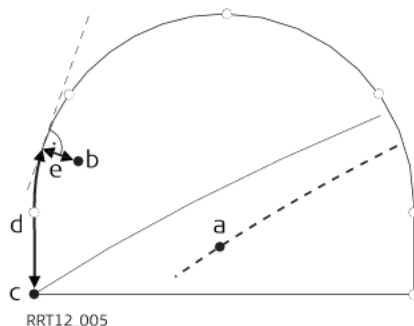

- a) Centre line
- b) Point on tunnel face to stake
- c) Point defining start of design profile
- d) Distance from start of design profile
- e) Offset perpendicular to design profile

Distance along a particular element

By the distance along a particular element of the design profile and an offset from the element.

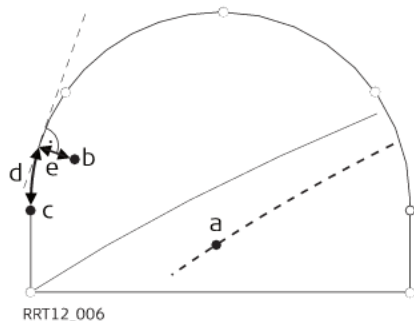

- a) Centre line
- b) Point on tunnel face to stake
- c) Element of design profile to stake
- d) Distance from start of design profile element
- e) Offset perpendicular to design profile

1.3.2

Tunnel Profiles

Staking tunnel profiles

Tunnel Profiles are normally staked after excavation to indicate the position of tunnel design elements or services such as lighting or ventilation.

Basic terms

Usually a tunnel under construction is designed and built in various stages such that a given chainage can have various design profiles (e.g. shotcrete, final lining...). Each design profile is called a layer.

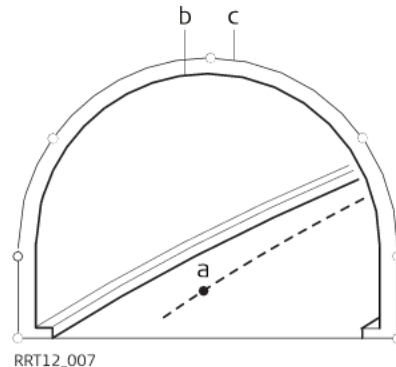

- a) Centre line or axis
- b) Final lining
- c) Shotcrete

Working areas

A tunnel profile is defined by its chainage and the design profile assigned to that chainage. Points to stake on any layer of the design profile may be defined using the same methods as those used to stake the tunnel face.

When staking out in a tunnel, it is normally the case that the excavated profile does not coincide exactly with the design profile. In these cases, the irregular form of the excavated profile may mean that it is not possible to stake a particular point at a particular chainage from a given instrument position (e.g. in a tight curve).

For this reason, a tight tolerance may be used to determine whether a staked point be accepted or not, the stake out process will stop once a measured point is within the tight tolerance limits.

In extreme cases where the instrument positions itself very far away from the point to stake, it may not be worth trying to stake the point. In this case a bailout tolerance may be introduced. If a measured point is outside of the bailout tolerance during the stake out iteration process, the stake out of the point is abandoned.

The bailout tolerance may also be exceeded if an obstruction such as plant machinery is situated between the measurement sensor and the point being measured.

Plan view

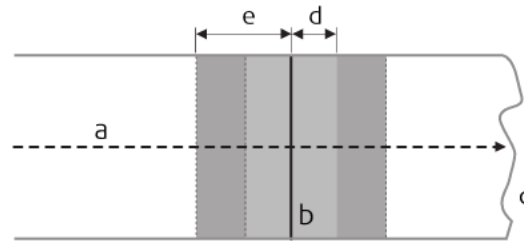

RRT12_008

- a) Centre line
- b) Profile to stake
- c) Tunnel face
- d) Tight tolerance
- e) Bailout tolerance

Measuring tunnel profiles

Tunnel Profiles are normally measured after excavation to compare the excavated profile with the design profile during the excavation phase of the project or for quality control checks of the built tunnel.

When measuring tunnel profiles, it is possible to scan various profile from one instrument position. The profiles to scan are defined with respect to a defined chainage. Profiles may be scanned at a given forward and back interval within a given forward and back distance from the defined profile.

Plan view

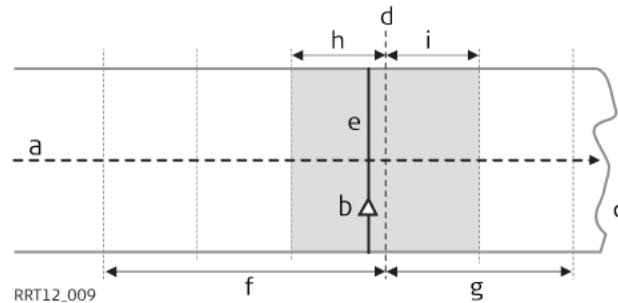

- a) Centre line
- b) Instrument position
- c) Tunnel face
- d) Defined profile to scan
- e) Instrument profile
- f) Back distance
- g) Forward distance
- h) Back interval
- i) Forward interval

Profile view

Tunnel profiles may be measured vertically, horizontally or perpendicular to the tunnel centre line.

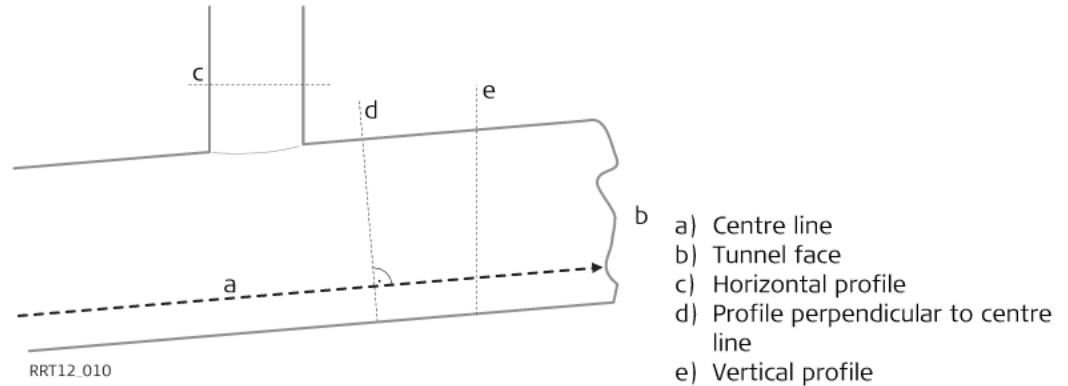

1.4

General



Shifts

When working on site, it is often the case that design data does not match the measured data. For example, an existing road surface that should intersect with the design surface may be 15 cm higher than the plans indicate. To guarantee a smooth intersection, this difference has to be distributed over the remaining 100 m of paving. To handle these situations, Road-Runner allows the possibility of adding shifts to the existing design data. A shift is applied when selecting the element to stake out/check.

Shifts do not change the stored design. They are applied temporarily for stake out purposes.

1.4.1

Centre Line Shifts

Horizontal and vertical shifts

Horizontal shifts are always perpendicular to the centre line whereas vertical shifts are applied along the plumb line.

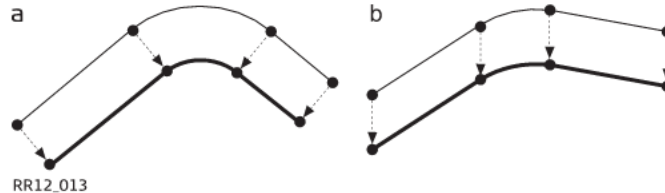

RR12_013

- a) Horizontal alignment with constant shift (Plan View)
- b) Vertical alignment with constant shift (Profile View)

Constant and linear shifts are supported

For both horizontal and vertical shifts two different types are available (can be applied):

Constant:

The shift remain the same from its start chainage or station to the end chainage or station.

Linear:

The shift is linearly interpolated along the chainage or station.

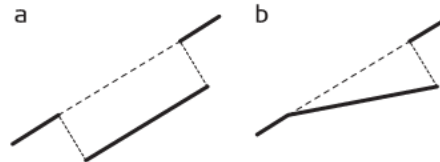

RRT12_025

- a) Constant shift
- b) Linear shift

Sign convention

The sign convention for design shifts is identical to that used for centre line offset and height shifts difference.

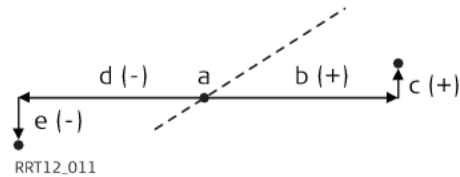

- a) Centre line
- b) Positive horizontal shift
- c) Positive vertical shift
- d) Negative horizontal shift
- e) Negative vertical shift

1.4.2

Design Profile Shifts

Profile shift

A shift may be applied to the design profile. The shift is applied perpendicularly to the design profile at any point along the design profile.

A positive shift will increase the size of the profile, a negative shift will decrease the size of the profile.

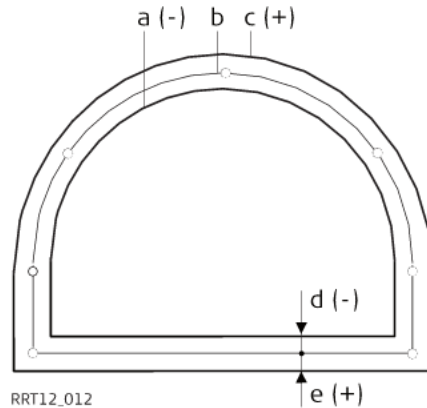

RRT12_012

- a) Design profile with negative shift
- b) Original design profile
- c) Design profile with positive shift
- d) Negative shift
- e) Positive shift

2

Getting Started

2.1

Preparing Design Data

Downloads section

The tunnel design data may be imported for use on-board the sensor using the industry standard LandXML data format or in formats exported from a number of other design packages using the Design to Field component of the Leica Geo Office PC application. Converters are available for more than 15 different design packages.



The latest version of the Design to Field importers may be found in the Downloads section of the Leica Geosystems web site at http://www.leica-geosystems.com/s-e/en/downloads/lgs_page_catalog.htm?cid=4948

2.1.1

Basics

Design to field

Tunnel Centreline

The tunnel centre line may be defined in two or three dimensions. A 3-dimensional centre line is required if design profiles are to be used.



To import a centre line using the Design to Field component select the **Tools/Design to Field** option of the Leica Geo Office PC application.

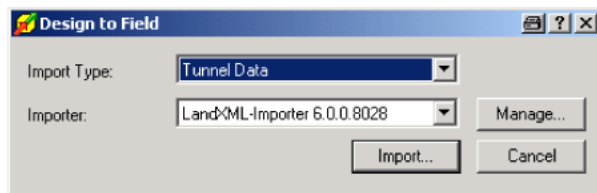

For general information about Design to Field please refer to the Leica Geo Office Manual or Online Help.

2.1.2**Design Profiles****Tunnel design profiles**

If tunnel design profiles are available, they may be created using the Tunnel Profile Editor PC application. This application is integrated in the Design to Field viewer. It allows to import or create tunnel data like profiles, layers and rotations. Refer to the Tunnel Profile Editor online help for more information.

Tunnel Profile Editor, Profile details view

X	Y	Type	Radius	Length	Center X	Center Y
-0.700	0.000	Line		0.100		
-0.700	0.100	Line		0.200		
-0.900	0.100	Curve	1.000	2.045	-0.007	0.550
0.000	1.550	Curve	1.000	2.045	0.007	0.550
0.900	0.100	Line		0.200		
0.700	0.100	Line		0.100		

Tunnel Profile Editor, Layer details view

The screenshot shows the 'Tunnel Profile Editor' application window. The main workspace is currently empty, with a red rectangular selection box visible. Below the workspace is a table with two columns: 'Chainage' and 'Theoretical Profile'. The table contains two rows of data. To the right of the table is a preview window showing a semi-circular tunnel cross-section with a dashed vertical centerline and a horizontal baseline. The bottom status bar displays the coordinates '130.993 ; 0.447', the units 'Meters Percent', and the copyright notice '© Leica Geosystems AG'. The taskbar at the bottom shows several open windows: 'Final Layer', 'Layers Overview', 'Final Layer', and 'Profiles Overview'.

Chainage	Theoretical Profile
130.000	Final Layer
200.000	Final Layer

2.1.3

Getting data onboard

Data transfer to sensor

Once the design data have been converted, copy the database files to the DBX folder of the CompactFlash card that will be used on the sensor. The file names are "jobname.x??".

These files are:

- Fixpoint job
- Meas job
- Tunnel job

2.2

Using the On-Board Application

Installation and licencing

The RoadRunner Tunnel application is an "add-on" component of the RoadRunner TPS1200 program. It is necessary that both the RoadRunner and RoadRunner Tunnel applications are loaded on the sensor before starting.

Both the RoadRunner and RoadRunner Tunnel applications are protected. They may be activated through a specific licence key. This licence key may be typed-in either through the Main Menu: Tools...\Licence Keys or, alternatively, the first time the application program is started.

2.2.1

Starting RoadRunner Tunnel

Selecting the Application

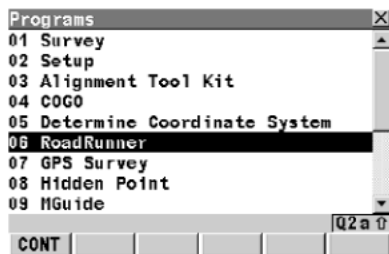

1. Select **Main Menu: Programs...**

OR

Press PROG.

2. TPS1200 Programs

Select **RoadRunner** in the menu.

3. **CONT (F1)** to access RoadRunner Begin panel.

2.2.2

RoadRunner Begin

Positioning the TPS

This screen shows the following:

To select the coordinate system, codelist, configuration set and reflector for the survey.

```

RoadRunner Begin
Coord System :      CS
CodeList      :      <None>
Config Set   :      TCRP
Reflector    :      Reflectorless
Add. Constant:      34.4 mm

CONT  CONF  SETUP  RESUM  CSYS

```

CONT (F1)

To continue to the next screen.

CONF (F2)

To access the configuration settings.
Refer to "7 Configuration".

SETUP (F3)

To set up an instrument station by determining the station coordinates and orienting the horizontal circle.

RESUM (F4)

To resume the last used and stored task. This is a recommended feature when using Advanced mode.

CSYS (F6)

To change the current coordinate system.

Field	Description of Field
Coord System	Output. The active coordinate system. Use CSYS (F6) to change the coordinate system. Tunnel jobs are defined in local grid coordinates. The right coordinate system must be chosen for the tunnel job.
Codelist	Choicelist. The active codelist. All codelists from Main Menu: Manage...\Codelists can be selected.
Config Set	Choicelist. The active configuration set. All configuration sets from Main Menu: Manage...\Configuration Sets can be selected.

Field	Description of Field
Reflector	Choicelist. The reflector currently set in the selected configuration set. All reflectors from 'Main Menu: Manage...\Reflectors' may be selected.
Add. Constant	Output. The additive constant stored with the chosen reflector.

2.2.3

RoadRunner Setup

RoadRunner Setup

This screen shows the following:

An overview of the setup information selected for the survey.

```

RoadRunner Setup
Application : RR Tunnel
Stake/Check : Stake
Method      : Stake Face
Mode        : Advanced
Project     : Soccer
Fixpoint Job : Default
Meas Job    : Default
Tunnel Job  : Tunnel 2 Layers
DTM Job     : <None>
CONT CONF PROJ DATA
  
```

CONT (F1)

To continue to the next screen.

CONF (F2)



To access the configuration settings.
Refer to "7 Configuration".

PROJ (F4)

To edit the currently selected project.
Refer to "5 Project and Job Management".

DATA (F5)

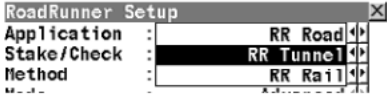
To view/edit the data in the tunnel job.
Refer to "6.4 Viewing and Editing the Design Data".

Field	Description of Field
Application	To select the relevant program. This field lists all of the programs that have been loaded into the RoadRunner group. Ensure that RR Tunnel is selected. 
Stake/Check	To select either Stake or Check for the survey. 

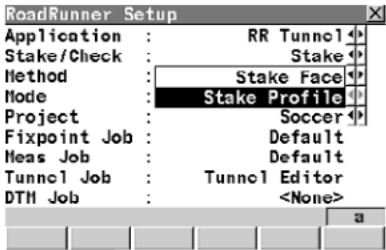
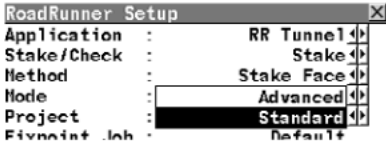
Field	Description of Field
Method	<p>To select the relevant method for the survey. All stake/check methods are listed.</p>  <p>The screenshot shows the 'RoadRunner Setup' dialog box with the following settings: Application: RR Tunnel, Stake/Check: Stake, Method: Stake Profile, Mode: Stake Profile, Project: Soccer, Fixpoint Job: Default, Meas Job: Default, Tunnel Job: Tunnel Editor, DTM Job: <None>. The 'Stake Profile' option is highlighted in the Method and Mode dropdown menus.</p>
Mode	<p>To select either Standard mode or Advanced mode.</p>  <p>The screenshot shows the 'RoadRunner Setup' dialog box with the following settings: Application: RR Tunnel, Stake/Check: Stake, Method: Stake Face, Mode: Standard, Project: Standard, Fixpoint Job: Default. The 'Standard' option is highlighted in the Mode dropdown menu.</p>
Project	To select the relevant project for the survey.
Fixpoint Job	The fixpoint job, as defined by the project.
Meas Job	The measure job, as defined by the project.
Tunnel Job	The tunnel job, as defined by the project.
DTM (Digital Terrain Model) Job	The DTM job, as defined by the project.

3 Checking and Measuring the Tunnel

3.1 Overview

Check and measure

The Check Profile and Scan Profile options can be accessed from the RoadRunner Tunnel Setup panel, when Stake/Check=Check.

The **Check Profile** option allows any point, anywhere in the tunnel to be checked against the design values. If no design profile has been defined in the Tunnel Job, the measured point is analysed with respect to the horizontal and vertical alignment.

The **Scan Profile** option allows profiles of the tunnel, perpendicular to the centre line to be measured. Various profiles may be measured from one instrument position.

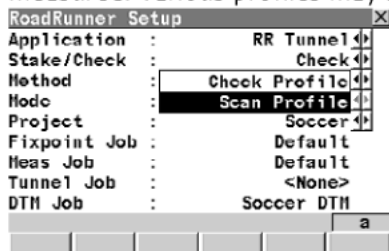

3.2

3.2.1

Standard mode

Checking Profiles

Working in Standard mode

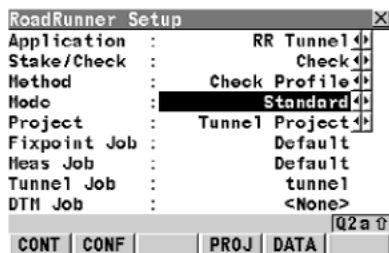

1. Selecting Mode=Standard.

For standard mode and using the Define Page, ensure that Mode=Standard is set.

Press 'CONT (F1)' to continue to the next screen.

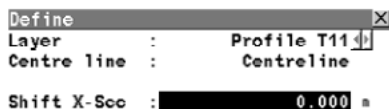

1. Working with the Define Page.

Layers contained in the active tunnel job can be selected from this page. These elements, combined with other settings on the page can easily be changed during the survey.

CONT (F1)

To continue to the next screen.

SHIFT CONF (F2)

To access the configuration settings.
Refer to "7 Configuration".

Press 'CONT (F1)' to continue to the next screen.

Field	Description of Field
Layer	Choicelist. To select a layer in the active tunnel job.

Field	Description of Field
Centre line	Output. The name of the layer centre line.
Shift X-Sec	User Input. The tunnel profile can be shifted horizontally to define another tunnel with a constant offset from the Centre line. The shape and the size of the tunnel profile will not be changed.

3.2.2

Working in Advanced mode

Advanced mode

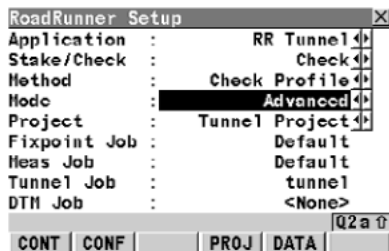

RoadRunner Setup

Application :	RR Tunnel
Stake/Check :	Check
Method :	Check Profile
Mode :	Advanced
Project :	Tunnel Project
Fixpoint Job :	Default
Heas Job :	Default
Tunnel Job :	tunnel
DTH Job :	<None>

Q2 a 0

CONT CONF PROJ DATA

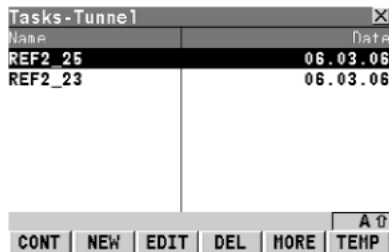

Tasks - Tunnel

Name	Date
REF2_25	06.03.06
REF2_23	06.03.06

A 0

CONT NEW EDIT DEL MORE TEMP

1. Selecting Mode=Advanced.

For advanced mode and using Tasks, ensure that Mode=Advanced is set.

Press 'CONT (F1)' to continue to the next screen.

2. Working with Task management.

In order to check a profile, a task needs to be created to define the shifts to be used during the check.

CONT (F1)

Selects the highlighted task and proceeds to the next screen.

NEW (F2)

Starts the task wizard.

TEMP (F3)

Creates a temporary task.



More information on shifts can be found in chapter "1.4 Shifts".



More information on creating tasks can be found in chapter "6.3 Tasks".

3.2.3

Checking the Profile

Settings

The **Check Profile** dialogue allows any point of the tunnel to be checked against the design values. If no design profile has been defined in the Tunnel Job, the measured point is analysed with respect to the horizontal and vertical alignment.

Enter Information regarding the measured point in the General panel of the Check Profile dialogue.

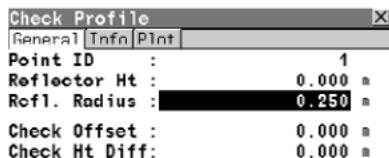

The screenshot shows the 'Check Profile' dialog box with the 'General' tab selected. The fields are as follows:

Field	Value
Point ID	1
Reflector Ht	0.000 m
Ref1. Radius	0.250 m
Check Offset	0.000 m
Check Ht Diff	0.000 m



The screenshot shows the footer controls of the dialog box, including a list of filter options and page navigation buttons.

Filter	Page
ALL	<PAGE PAGE>
DIST	
REC	

Point ID

The measured point will be recorded with the point ID displayed on the screen.

Reflector Ht

If a reflector is used, the vertical difference between the point to be measured and the point of the reflector pole should be entered.

Check Offset

Applies a horizontal shift perpendicular to the centre line used for comparing to the measured point.

Check Ht Diff

Applies a vertical shift to the centre line used for comparing to the measured point.



The **ALL (F1)**, **DIST (F2)**, **REC (F3)**, **< PAGE (F5)** and **PAGE > (F6)** keys have the same functionality as throughout the rest of System 1200.

Results

The differences between the measured and design data may be viewed in the Info panel of the **Check Profile** dialogue.

The parameters viewed in the **Info** panel may be configured by the user in the **Info&Plot** page of the application configuration.

The configuration may be accessed using the **CONF (SHIFT-(F2))** key. Refer to chapter "7 Configuration" for more details regarding the application configuration.

In this screen the most important values for checking the measured point against the design are:

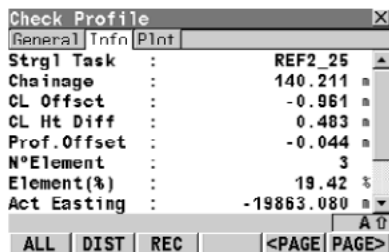

Check Profile	
General	Info
Strgl Task :	REF2_25
Chainage :	140.211 m
CL Offset :	-0.981 m
CL Ht Diff :	0.483 m
Prof. Offset :	-0.044 m
N°Element :	3
Element(%) :	19.42 %
Act Easting :	-19863.080 m

ALL | DIST | REC | <PAGE | PAGE>

CL Offset

The plan distance from the measured point to the horizontal alignment.

CL Ht Diff

The vertical distance between the vertical alignment and the measured point.

Prof. Offset

The perpendicular distance between the measured point and the design profile. A measured point that is located inside of the design profile will always have a negative profile offset.

Radial offset

When using a reflector to check a design profile it is important to take into account the reflector radius parameter in the **General** page of the application configuration.

If this parameter is set to **Yes**, the measured point will be projected by a distance equivalent to the radius of the reflector in a direction perpendicular to the tangent of the design profile. If this parameter is set to **No**, the design profile will be compared to the coordinates of the centre of the reflector at the measured position.

If reflectorless measurements are used or no design profile is has been defined, the reflector radius parameter will not be used in the calculation.

The **Plot** panel of the **Check Profile** dialogue displays a plot of the measured point with respect to the design profile.

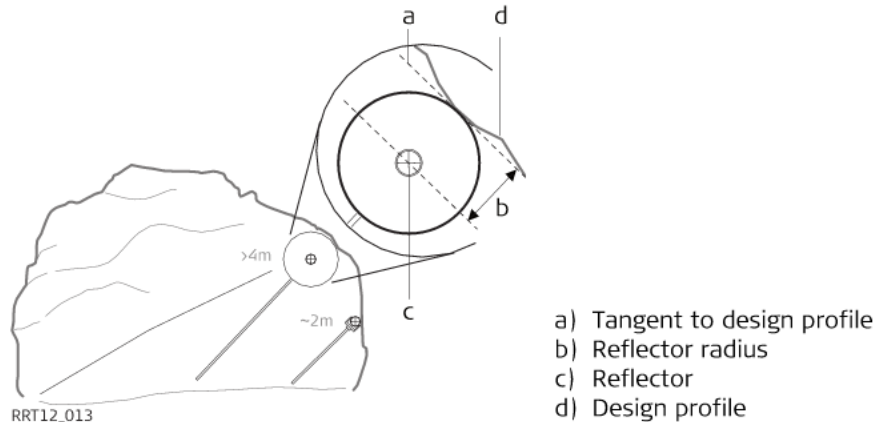

3.3 Scanning Profiles

3.3.1 Working in Standard mode

Standard mode

```

RoadRunner Setup
Application : RR Tunnel
Stake/Check : Check
Method : Scan Profile
Mode : Standard
Project : Tunnel Project
Fixpoint Job : Default
Meas Job : Default
Tunnel Job : tunnel
DTM Job : <None>

CONT CONF PROJ DATA
  
```

1. Selecting Mode=Standard.

For standard mode and using the Define Page, ensure that Mode=Standard is set.

Press 'CONT (F1)' to continue to the next screen.

```

Define
Layer : Profile T11
Centre line : Centreline

Shift X-See : 0.000
  
```

2. Working with the Define Page.

Layers contained in the active tunnel job can be selected from this page. These elements, combined with other settings on the page can easily be changed during the survey.

```

CONT CONF PROJ DATA
  
```

CONT (F1)

To continue to the next screen.

SHIFT CONF (F2)

To access the configuration settings.
Refer to "7 Configuration".

Press 'CONT (F1)' to continue to the next screen.

Field	Description of Field
Layer	Choicelist. To select a layer in the active tunnel job.

Field	Description of Field
Centre line	Output. The name of the layer centre line.
Shift X-Sec	User Input. The tunnel profile can be shifted horizontally to define another tunnel with a constant offset from the Centre line. The shape and the size of the tunnel profile will not be changed.

3.3.2

Working in Advanced mode

Advanced mode

RoadRunner Setup	
Application :	RR Tunnel
Stake/Check :	Check
Method :	Scan Profile
Mode :	Advanced
Project :	Tunnel Project
Fixpoint Job :	Default
Meas Job :	Default
Tunnel Job :	tunnel
DTM Job :	<None>
Q2a	
CONT	CONF
PROJ	DATA

Tasks - Tunnel	
Name	Date
REF2_25	06.03.06
REF2_23	06.03.06

					A
CONT	NEW	EDIT	DEL	MORE	TEMP

1. Selecting Mode=Advanced.

For advanced mode and using Tasks, ensure that Mode=Advanced is set.

Press 'CONT (F1)' to continue to the next screen.

2. Working with Task management.

In order to scan profiles, a task must be created and the instrument must be stationed and oriented. Once the task has been selected and the instrument stationed, the parameters for the scan have to be entered.

CONT (F1)

Selects the highlighted task and proceeds to the next screen.

NEW (F2)

Starts the task wizard.

TEMP (F3)

Creates a temporary task.



More information on shifts can be found in chapter "1.4 Shifts".



More information on creating tasks can be found in chapter "6.3 Tasks".

3.3.3

Profile settings

Defining Profiles to Scan

When measuring tunnel profiles, it is possible to scan various profiles from one instrument position. Note that the instrument will always measure the profile in the chainage where the instrument is stationed before measuring additional profiles.

If it is required to measure more than one profile from an instrument position, the profiles to scan are defined with respect to a defined chainage. This defined chainage, **Profile Chain**, may or may not coincide with the chainage at which the instrument is stationed. Profiles may be scanned at a given forward (**Fwd Interval**) and back interval (**Back Interval**) within a given forward (**Fwd Distance**) and back distance (**Back Distance**) from the defined profile.

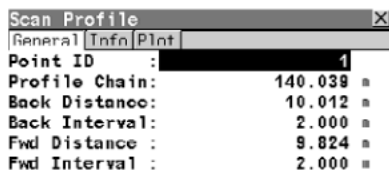

```
Scan Profile [X]
General Info Print
Point ID : 1
Profile Chain: 140.039 m
Back Distance: 10.012 m
Back Interval: 2.000 m
Fwd Distance : 9.824 m
Fwd Interval : 2.000 m
```



```
START GET B GET F MANU <PAGE PAGE>
```

Planview

A graphical representation of the parameters may be seen below.

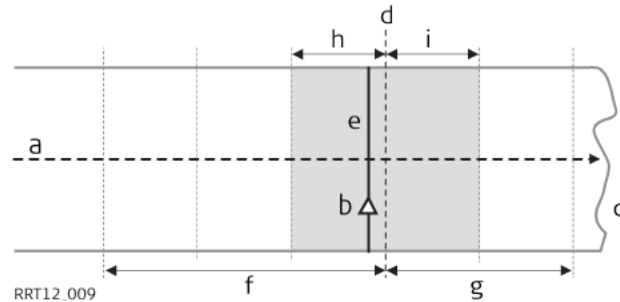

- a) Centre line
- b) Instrument position
- c) Tunnel face
- d) Defined profile to scan
- e) Instrument profile
- f) Back distance
- g) Forward distance
- h) Back interval
- i) Forward interval

Defining the Interval

The limits for the profile measurements, forward distance and back distance, may be entered manually in the **General** panel of the **Scan Profile** dialogue or may be measured using the **GET B** and **GET F** keys:

GET B (F2)

Measures a distance from the instrument position and calculates the difference in chainage between the measured point and the chainage of the instrument position. The calculated difference is then set as the **Back Distance**.

GET F (F3)

Measures a distance from the instrument position and calculates the difference in chainage between the measured point and the chainage of the instrument position. The calculated difference is then set as the **Forward Distance**.

Note that the measured point for a back distance must always be at a chainage less than the chainage of the instrument position. The measured point for a forward distance must always be at a chainage greater than the chainage of the instrument position. If these conditions are not met, an error message will be displayed and it will be necessary to redefine the distance.

3.3.4

Scan Limits

Inclusive and exclusive sections

Once the chainages of the profiles to scan have been defined, and before starting the measurement, it is necessary to define the limits of the scan.

The scan limits are used to define the angular limits to be scanned in a plane perpendicular to the centreline. These limits normally define the starting point and end point of the profile to scan as well as any zone that should not be measured.

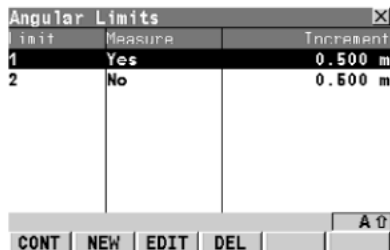

Limit	Measure	Increment
1	Yes	0.500 m
2	No	0.500 m

CONT NEW EDIT DEL A

The scan limits can be defined using the **LIMIT (SHIFT-(F5))** key in the **Scan Profile** dialogue.

Limits are defined with respect to the instrument axis. In the following example a limit is defined that includes the entire area to be scanned (Limit 1) and an overlapping area (Limit 2) that should not be scanned because a ventilation shaft is obstructing a clear view of the tunnel surface.

Any number of limits may be defined. In addition each limit needs to be defined as an include limit (ie. measure within the defined zone) or an exclude limit (ie. do not measure within the defined zone). If overlapping zones are defined, an exclude limit has priority over an include limit.

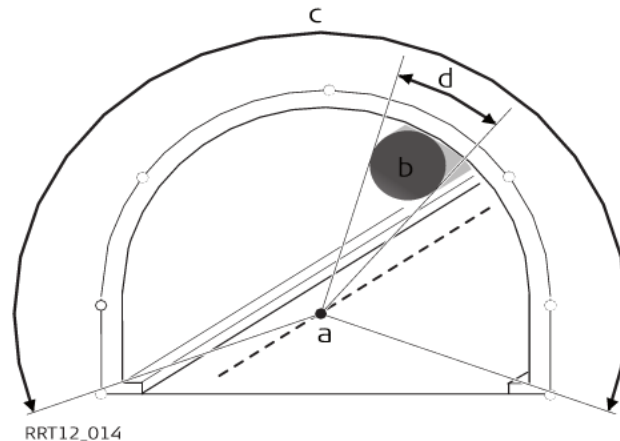

- a) Instrument axis
- b) Ventilation shaft
- c) Include limit
- d) Exclude limit



New limits can be defined by pressing the **NEW (F2)** button in the **Angular Limits** dialogue.

To define a limit

New Angular Limits		X
Hz	:	379.3453 g
V	:	98.7782 g
Slope Dist	:	40.116 m
Limit Name	:	3
Angle Start	:	98.0880 g
Angle End	:	98.7782 g
Meas. Status	:	No
Increment	:	0.500 m
CONT	DIST	POSIT
		A T

1. Enter the **Limit Name** and place the cursor on the **Angle Start** line.
2. Turn the instrument to point at the starting angle of the limit.
3. Press the **DIST (F2)** key to measure the distance.
4. Move the cursor to the **Angle End** line.
5. Turn the instrument to point at the end angle of the limit.
6. Press the **DIST (F2)** key to measure the distance.
7. Decide on whether the limit is an include limit within which points should be measured (**Meas.Status = Yes**) or an exclude limit which should not be measured (**Meas.Status = No**)
8. If the measurement status is set to **Yes**, enter the approximate distance between points to be measured on the line Increment.



The position of the limit can be reviewed once it has been defined by placing the cursor on the **Angle Start** or **Angle End** line and pressing the **POSIT (F4)** key. The instrument will turn to the corresponding angle.

Store a limit

Once the limit has been defined, it can be stored using the **CONT (F1)** key. The application will then return to the **Angular Limits** dialogue.

Limit	Measure	Increment
1	Yes	0.500 m
2	No	0.500 m

CONT NEW EDIT DEL A

Once the limits have been defined they may be edited from the **Angular Limits** dialogue by pressing the **EDIT (F3)** key or deleted by pressing the **DEL (F4)** key.

To return to the **Scan Profile** dialogue after defining the angular limits, press the **CONT (F1)** key.

3.3.5

Defining Discrete Points to Measure

Measure additional points

In addition to defining the chainage and the angular limits of the profiles to scan, it is also possible to define discrete points in the profile that should be measured at each chainage.

These points could represent a breakpoint in the section, for example, or a point that is required for positioning services such as electricity cables.

To define a manual point:

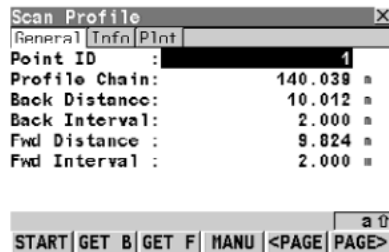

1. Press the **MANU (F4)** button in the **Scan Profile** dialogue.
2. Aim at the point to measure.
3. Use the **ALL (F1)**, **DIST (F2)** and **REC (F3)** keys to measure the point in the usual manner.
4. Repeat the process for all of the manual points that are required to be added to the profile.

3.3.6

Making a Scan

Starting the scan

Once all manual points have been defined, the scanning of the profiles may commence by pressing the **AUTO (F4)**. If no manual points are required, scanning of the profiles may be started by pressing the **START (F1)** key.

Once scanning has started, the values of the measured point may be viewed in the Info panel of the **Scan Profile** dialogue. The values shown in this panel may be configured in the application configuration. Refer to chapter "7 Configuration" for more information on modifying the Info panel.

It is possible to abort the scan once started using the **STOP (F1)** key. Should it be necessary to pause the scan, for example to allow passing site traffic through, this can be done using the **PAUSE (F2)** key.

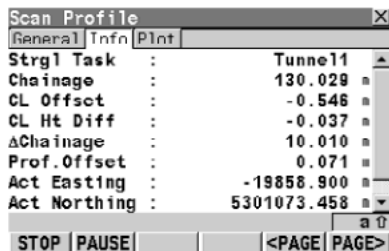

Pause and options before continuing

Once the scan has been paused, the user has several options available before continuing:

```
Scan Profile [X]
General Info Print
Point ID : 56
Profile Chain: 140.039 m
Back Distance: 10.012 m
Back Interval: 2.000 m
Fwd Distance : 9.824 m
Fwd Interval : 2.000 m
```

```
STOP RESUM PROF+ MANU <PAGE> PAGE>
```

STOP (F1)

Aborts the scan

RESUM (F2)

Continue the scan at the next position. Turn the instrument to skip a section of the profile if needed.

PROF+ (F3)

Skips the remaining points in the profile being measured and moves onto the next profile.

MANU (F4)

Allows a point measured manually to be added to the measured profile. The automatic scan may be resumed by pressing the **AUTO (F4)** key if this key has been pressed.

Scan settings

Whilst scanning, the application makes a series of checks based on the values entered in the Scan page of the application configuration. These checks ensure that the measurements are within the required tolerance values.



CONF (SHIFT-(F2))

To open the Scan page of the configuration within the application.

Scan Mode

The **Scan Mode** indicates the type of profile to be scanned. Vertical and perpendicular (tilted) profiles are supported.

Rotn.Method

The **Rotn.Method** defines how the distance between points is defined. At the present time, the only available method is by distance.

Chain.Limit

The **Chain.Limit** defines the maximum difference in chainage with which a point will be recorded. It is also related to the **Max.Iterations** parameter. When measuring parallel profiles it is necessary to check the measured chainage of a point against the nominal chainage. Since no information is available regarding the tunnel surface before scanning, the theoretical position of the point is measured.

If the difference between the measured values and the nominal values are greater than the chainage limit, the instrument iterates to a new position where its calculated point is likely to be.

Invalid measurements

This process is repeated until the measured point is within the chainage limit or the maximum number of iterations has been reached.

Should this happen, the user is advised that it has been unable to measure the point. This situation could occur, for example, in irregular tunnel surfaces, where the horizontal alignment is formed by a curve with a small radius or if the back distance or forward distance defined in the **General** page of the **Scan Profile** dialogue were too large.

Tolerance values

The tight behaviour (**Tight Behav.**), tolerance (**Tight Toleran**) and **Tight Ignore** refer to the distance of the measured point from the design profile. If the distance between the measured point and the design profile is greater than the tight tolerance and less than the tight ignore value, the application will perform the action defined as the tight behaviour. This may be Store all the values, Store only those values within the defiend tolerances, Pause the application with a warning message and store the values or pause the application with a warning message.



It is possible to return to the **Scan Profile** dialogue from the configuration by pressing the **CONT (F1)** key.

4

Setting Out the Tunnel

4.1

Overview

Stake Face and Profile

The Stake Face and Stake Profile options can be accessed from the RoadRunner Setup Panel.

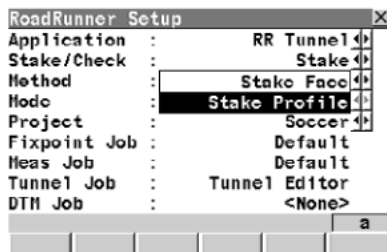

CONT (F1)

Select the required option and press the **CONT (F1)** key to proceed.

The **Stake Face** option allows any point on the excavation face of the tunnel to be set out. The points to set out may be defined with respect to the horizontal and vertical alignment or to the design profile.

The **Stake Profile** option allows any point at a given chainage in the tunnel to be staked. The points to set out may be defined with respect to the horizontal and vertical alignment or to the design profile.

4.2

Setting Out the Tunnel Face

Overview

When excavating a tunnel, it is usually required to set out the tunnel portal before excavation can begin. In addition, for excavation methods other than those involving tunnel boring machines (TBM's), it is then usually required to set out the tunnel face at given intervals during the excavation.

The tunnel face can be set out at any time within the System 1200 RoadRunner Tunnel application using the **Stake Face** function.

This function allows the setting out of a series of points perpendicular to the horizontal alignment that indicate the position of the design profile at the chainage of the tunnel face.

Cross-Section View

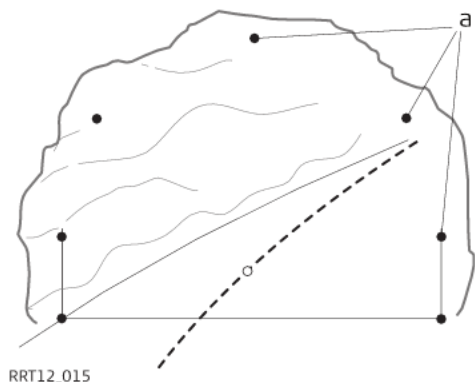

a Points to set out

Given that it is likely that a degree of rock debris is present at the tunnel face or that inexact excavation techniques such as blasting are used, it cannot be assumed that the tunnel face at any stage of the excavation is perpendicular to the horizontal alignment.

This in turn implies that we cannot set out a point on the tunnel face at a given chainage as the chainage of the tunnel face at any particular point is unknown. Iterative techniques are necessary to enable any defined point on the tunnel face to be set out accurately.

The **Stake Face** function involves setting out a point on the tunnel face at this unknown chainage. First of all the point to set out on the tunnel face is set out at an approximate chainage (e).

The point may be defined by offsets with respect to the centre line or by its position along the design profile and its offset from the profile. Given that the excavated tunnel face does not intersect the defined chainage, another point (e') is measured.

1st iteration

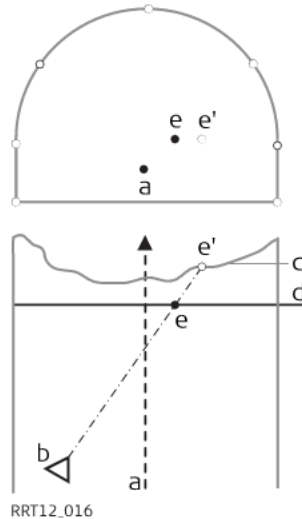

- a) Centre line
- b) Instrument position
- c) Tunnel face
- d) Approximate chainage to set out
- e) Point to set out at approximate chainage
- e' Point set out on tunnel face

The true chainage of the measured point of the first iteration (e') is then calculated and the defined point (e) is set out at the calculated chainage (d).

2nd iteration

This process is repeated until the differences between set out point and the defined point are within a tolerance set by the user.

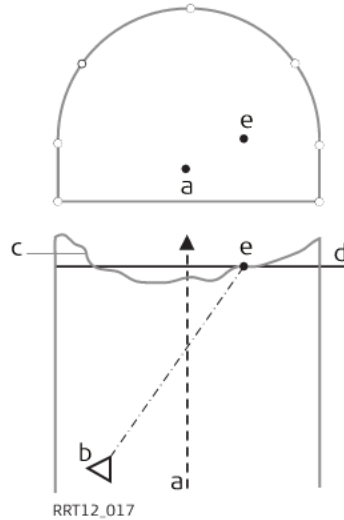

- a) Centre line
- b) Instrument position
- c) Tunnel face
- d) Calculated chainage from 1st iteration
- e) Point to set out at calculated chainage

4.2.1

Working in Standard mode

Standard mode

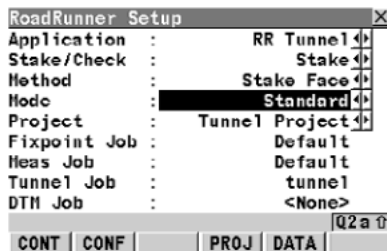

RoadRunner Setup

Application :	RR Tunnel
Stake/Check :	Stake
Method :	Stake Face
Mode :	Standard
Project :	Tunnel Project
Fixpoint Job :	Default
Heas Job :	Default
Tunnel Job :	tunnel
DTH Job :	<None>

Q2 a 0

CONT CONF PROJ DATA

1. Selecting Mode=Standard.

For standard mode and using the Define Page, ensure that Mode=Standard is set.

Press 'CONT (F1)' to continue to the next screen.

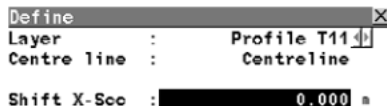

Define

Layer :	Profile T11
Centre line :	Centreline
Shift X-See :	0.000

2. Working with the Define Page.

Layers contained in the active tunnel job can be selected from this page. These elements, combined with other settings on the page can easily be changed during the survey.



Q2 a 0

CONT

CONT (F1)

To continue to the next screen.

SHIFT CONF (F2)

To access the configuration settings.
Refer to "7 Configuration".

Press 'CONT (F1)' to continue to the next screen.

Field	Description of Field
Layer	Choicelist. To select a layer in the active tunnel job.
Centre line	Output. The name of the layer centre line.

Field	Description of Field
Shift X-Sec	User Input. The tunnel profile can be shifted horizontally to define another tunnel with a constant offset from the Centre line. The shape and the size of the tunnel profile will not be changed.

4.2.2

Working in Advanced mode

Advanced mode

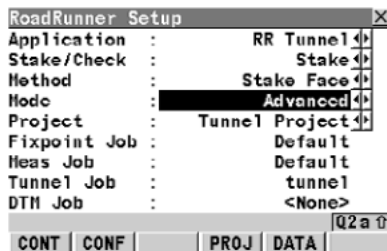

RoadRunner Setup

Application :	RR Tunnel
Stake/Check :	Stake
Method :	Stake Face
Mode :	Advanced
Project :	Tunnel Project
Fixpoint Job :	Default
Heas Job :	Default
Tunnel Job :	tunnel
DTH Job :	<None>

Q2 a 0

CONT CONF PROJ DATA

1. Selecting Mode=Advanced.

For advanced mode and using Tasks, ensure that Mode=Advanced is set.

Press 'CONT (F1)' to continue to the next screen.

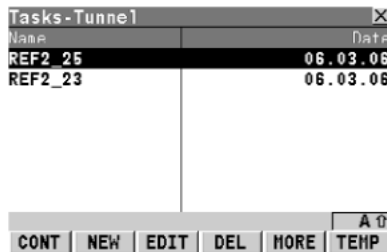

Tasks - Tunnel

Name	Date
REF2_25	06.03.06
REF2_23	06.03.06

A 0

CONT NEW EDIT DEL MORE TEMP

2. Working with Task management.

Before staking the tunnel face, a task needs to be created to define the shifts to be used during setting out.

CONT (F1)

Selects the highlighted task and proceeds to the next screen.

NEW (F2)

Starts the task wizard.

TEMP (F3)

Creates a temporary task.



More information on shifts can be found in chapter "1.4 Shifts".



More information on creating tasks can be found in chapter "6.3 Tasks".

4.2.3

Setting Out the Point

General Panel

The approximate chainage of the point to stake and the offsets from the centre line can be defined in the **General** panel of the **Stake Face** dialogue.

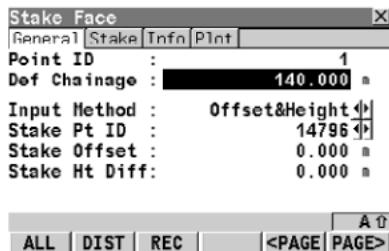
**Point ID**

The point identifier of the point that will be set out.

def Chainage

The defined or approximate chainage of the point to be set out.

Input Method

Three methods are available to define the position of the point to be set out:

- Offset & Height
- ProfDist & Offset
- Element & Offset

Offset & Height

- **Offset&Height:** The point is set out with a known perpendicular and vertical offset from the horizontal and vertical alignments respectively.
- If the **Offset&Height** method is used, the offsets of the point may be stored as coordinates in the fixpoint job.

- The **Stake Offset** may be stored as the X coordinate and the **Stake Height Difference** may be stored as the Y coordinate.
- To select a point stored in the fixpoint job, place the cursor on the **Stake Pt ID** and press the **ENTER** key.

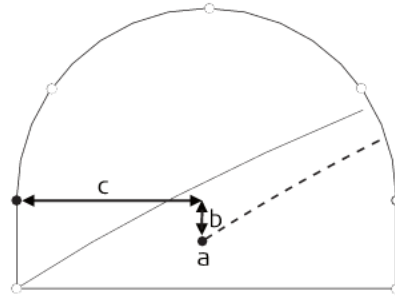

RRT12_018

- a) Centre line
- b) Centre line height difference
- c) Centre line Offset



For more information on working with points in the fixpoint job, refer to the TPS User manual.

ProfDist&Offset

The point is defined by the distance from the start of the profile and an offset perpendicular to the design profile.

If this option is used, enter the distance **Along Profile** and the **Profile Offset** to define the point to be set out.

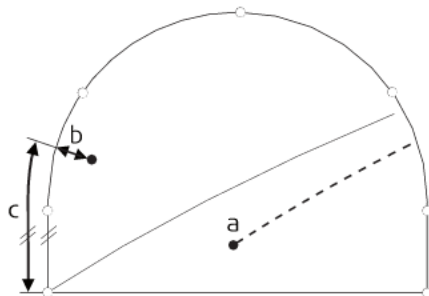

RRT12_019

- a) Centre line
- b) Profile offset
- c) Distance from start of design profile

Element&Offset

The point to set out is defined by the number of the element on which the point lies, the percentage of the distance along the element of the point to set out and the offset perpendicular to the design profile.

Element number 1 is the first element of the design profile. If the configuration parameter **Geometry** is set to **Clockwise** the number of each element increments in a clockwise direction. If this parameter is set to **CounterClockwise** the number of each element increments in a counter-clockwise direction.

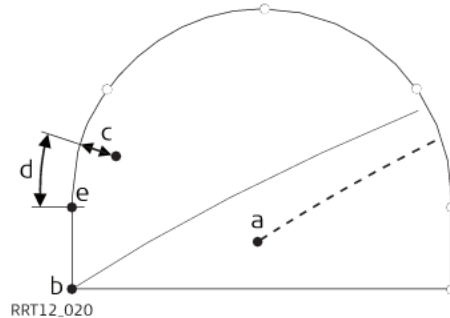

- a) Centre line
- b) Point defining start of design profile
- c) Offset perpendicular to profile segment
- d) Distance from start of Start point of segment
- e) Start point of segment



Auto positioning

Once the point to set out has been defined, the sensor may be positioned manually and the **ALL (F1)**, **DIST (F2)** and **REC (F3)** keys may be used to measure a point manually.

The **POSIT (SHIFT-(F5))** key may be pressed to stake the point automatically and start the iterative setting out process. The sensor will set out the point according to the process described in chapter "4.2 Setting Out the Tunnel Face" until:

- the number of iterations set as the configuration parameter **Max Iteration** is reached, or
- the difference between the measured point and the design point is less than the value set as the configuration parameter **Position Tol.**

Stake Face Panel

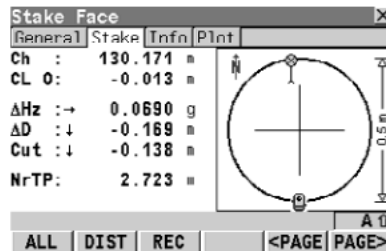

During stake out the differences between the measured point and the design point may be seen in the **Stake Face** panel.

The layout of this panel may appear with or without graphics depending upon the values set in the application configuration.



Refer chapter "7 Configuration" for more information on the configuration.

Info Panel

Stake Face	
General	Stake
Strgl Task	: REF2_25
Chainage	: 130.171 m
CL Offset	: -0.013 m
CL Ht Diff	: 0.138 m
ΔChainage	: -0.171 m
ΔOffset	: 0.013 m
ΔHeight	: -0.138 m
Dist to Point:	0.172 m
A 0	
ALL	DIST
REC	<PAGE
	PAGE>

The Info panel may be configured in the application configuration to display a series of values related to the setting out of the design point as required by the user.



Refer to chapter "7 Configuration" for more information on configuring the Info page.

4.3

Setting Out a Tunnel Profile

Overview

The **Stake Profile** option allows any point at a given chainage in the tunnel to be set out. The points to set out may be defined with respect to the horizontal and vertical alignment or to the design profile.

4.3.1

Working in Standard mode

Standard mode

```
RoadRunner Setup
Application : RR Tunnel
Stake/Check : Stake
Method : Stake Profile
Mode : Standard
Project : Tunnel Project
Fixpoint Job : Default
Heas Job : Default
Tunnel Job : tunnel
DTM Job : <None>
Q2 a 0
CONT CONF PROJ DATA
```

```
Define
Layer : Profile T11
Centre line : Centreline
Shift X-See : 0.000
```

```
Q2 a 0
CONT
```

1. Selecting Mode=Standard.

For standard mode and using the Define Page, ensure that Mode=Standard is set.

Press 'CONT (F1)' to continue to the next screen.

2. Working with the Define Page.

Layers contained in the active tunnel job can be selected from this page. These elements, combined with other settings on the page can easily be changed during the survey.

CONT (F1)

To continue to the next screen.

SHIFT CONF (F2)

To access the configuration settings.
Refer to "7 Configuration".

Press 'CONT (F1)' to continue to the next screen.

Field	Description of Field
Layer	Choicelist. To select a layer in the active tunnel job.
Centre line	Output. The name of the layer centre line.

Field	Description of Field
Shift X-Sec	User Input. The tunnel profile can be shifted horizontally to define another tunnel with a constant offset from the Centre line. The shape and the size of the tunnel profile will not be changed.

4.3.2

Working in Advanced mode

Advanced mode

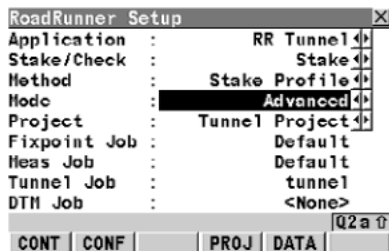

RoadRunner Setup

Application :	RR Tunnel
Stake/Check :	Stake
Method :	Stake Profile
Mode :	Advanced
Project :	Tunnel Project
Fixpoint Job :	Default
Heas Job :	Default
Tunnel Job :	tunnel
DTH Job :	<None>

Q2 a 0

CONT CONF PROJ DATA

1. Selecting Mode=Advanced.

For advanced mode and using Tasks, ensure that Mode=Advanced is set.

Press 'CONT (F1)' to continue to the next screen.

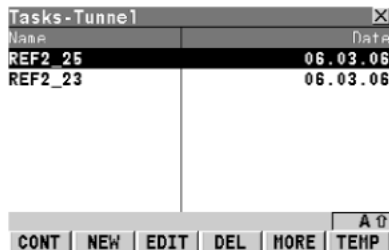

Tasks - Tunnel

Name	Date
REF2_25	06.03.06
REF2_23	06.03.06

A 0

CONT NEW EDIT DEL MORE TEMP

2. Working with Task management.

Before staking the tunnel profile, a task needs to be created to define the shifts to be used during setting out.

CONT (F1)

Selects the highlighted task and proceeds to the next screen.

NEW (F2)

Starts the task wizard.

TEMP (F3)

Creates a temporary task.



More information on shifts can be found in chapter "1.4 Shifts".



More information on creating tasks can be found in chapter "6.3 Tasks".

4.3.3

Setting Out the Point

General panel

The chainage of the point to stake and the offsets from the centre line can be defined in the **General** panel of the **Stake Profile** dialogue.

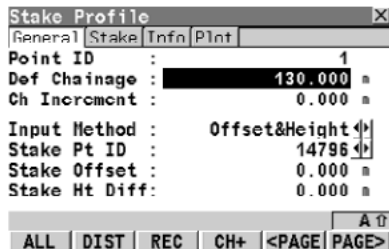

The screenshot shows the 'Stake Profile' dialog box with the 'General' tab selected. The fields are as follows:

Point ID :	1
Def Chainage :	130.000 m
Ch Increment :	0.000 m
Input Method :	Offset&Height
Stake Pt ID :	14796
Stake Offset :	0.000 m
Stake Ht Diff:	0.000 m

At the bottom, there are buttons for 'ALL', 'DIST', 'REC', 'CH+', '<PAGE', and 'PAGE>'. A small 'A' icon is also visible in the bottom right corner of the dialog box.

Point ID

The point identifier of the point that will be set out.

def Chainage

The defined or approximate chainage of the point to be set out.

Ch.Increment

If a point is to be staked at more than one chainage, a chainage increment may be defined. Once a point is set out at the current defined chainage and the **CH+1 (F4)** key is pressed, the defined chainage will be incremented by the chainage increment value to define a new point to set out with the same offsets at the incremented chainage.

Input Method

Three methods are available to define the position of the point to be set out:

Offset&Height

The point is set out with a known perpendicular and vertical offset from the horizontal and vertical alignments respectively.

If the **Offset&Height** method is used, the offsets of the point may be stored as coordinates in the fixpoint job. The **Stake Offset** may be stored as the X coordinate and the **Stake Height Difference** may be stored as the Y coordinate.

To select a point stored in the fixpoint job, place the cursor on the **Stake Pt ID** and press the **ENTER** key. For more information on working with points in the fixpoint job, refer to the TPS1200 User manual.

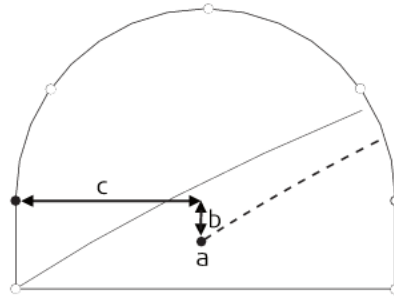

RRT12_018

- a) Centre line
- b) Centre line height difference
- c) Centre line offset



The chainage entered on the General page is used as horizontal chainage even if the tunnel job has perpendicular profiles.

ProfDist&Offset

The point is defined by the distance from the start of the profile and an offset perpendicular to the design profile. If this option is used, enter the distance **Along Profile** and the **Profile Offset** to define the point to be set out.

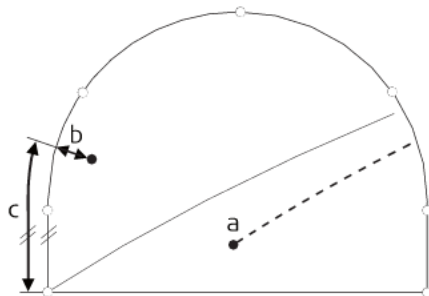

RRT12_019

- a) Centre line
- b) Profile offset
- c) Distance from start of design profile



If the tunnel job has perpendicular profiles the chainage entered on the General page is used as vertical chainage.

Element&Offset

The point to set out is defined by the number of the element on which the point lies, the percentage of the distance along the element of the point to set out and the offset perpendicular to the design profile. Element number 1 is the first element of the design profile. If the configuration parameter **Geometry** is set to **Clockwise** the number of each element increments in a clockwise direction. If this parameter is set to **CounterClockwise** the number of each element increments in a counter-clockwise direction.

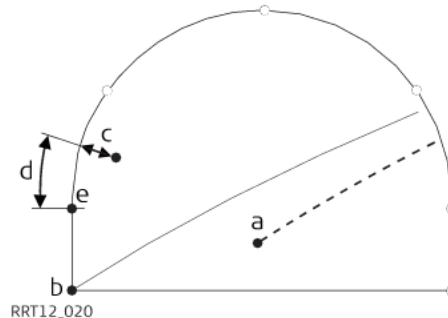

- a) Centre line
- b) Point defining start of design profile
- c) Offset perpendicular to profile segment
- d) Distance from start of Start point of segment
- e) Start point of segment



If the tunnel job has perpendicular profiles the chainage entered on the General page is used as vertical chainage.



Once the point to set out has been defined, the sensor may be positioned manually and the **ALL (F1)**, **DIST (F2)** and **REC (F3)** keys may be used to measure a point manually.

Auto positioning

The **POSIT (SHIFT-(F5))** key may be pressed to stake the point automatically. The sensor will aim towards the point at the given chainage and offsets and measure a distance. If this distance is not within the required tolerance an iterative process is started until:

- the number of iterations set as the configuration parameter **Max Iteration** is reached, or
- the difference between the measured point and the design point is less than the value set as the configuration parameter **Position Tol.**

Stake point on surface

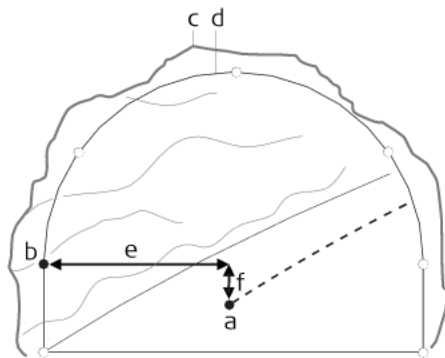

- a) Centre line
- b) Design point to set out
- c) Excavated profile
- d) Design profile
- e) Centre line offset
- f) Centre line height difference

If it is not possible to set out the defined point, as seen in the diagram, between successive iterations, the sensor will maintain the chainage and height difference from the vertical alignment fixed and modify the horizontal offset from the centre line to calculate the new position of the point. The point that will be set out will thus maintain the defined chainage and height difference but will have a modified offset value from the centreline.

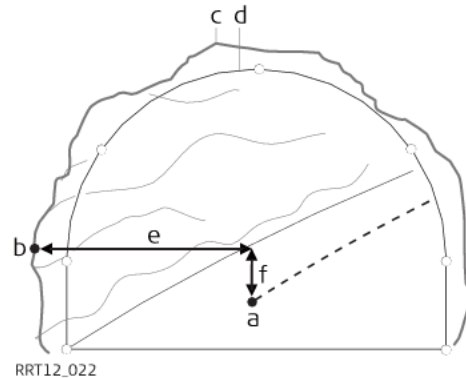

- a) Centre line
- b) Design point to set out
- c) Excavated profile
- d) Design profile
- e) Centre line offset
- f) Centre line height difference

Stake Profile panel

During stake out the differences between the measured point and the design point may be seen in the **Stake Profile** panel.

The layout of this panel may appear with or without graphics depending upon the values set in the application configuration.

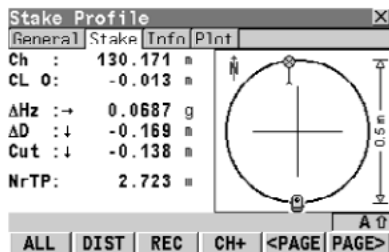

Refer to chapter "7 Configuration" for more information on the configuration.

Info panel

The **Info** panel may be configured in the application configuration to display a series of values related to the setting out of the design point as required by the user.

Stake Profile	
General	Stake
Strgl Task	: REF2_25
Chainage	: 130.171 m
CL Offset	: -0.013 m
CL Ht Diff	: 0.138 m
ΔChainage	: -0.171 m
ΔOffset	: 0.013 m
ΔHeight	: -0.138 m

ALL	DIST	REC	CH+	<PAGE	PAGE>
-----	------	-----	-----	-------	-------



Refer to chapter "7 Configuration" for more information on configuring the Info page.

5

Project and Job Management

5.1

Overview

Project data

Working on a tunnel construction site implies working with various data such as:

- Control points
- Horizontal and vertical alignments
- Measurement data
- Tunnel Profile design
- Digital Terrain Models

To avoid having to select individual data sets each time the application is used, data can be grouped into projects. This makes the selection much easier and reduces the risk of selecting wrong data set.

Project

A project consists of different kinds of jobs that are grouped together to form a project. By selecting a project automatically all referenced jobs are selected as well. A project can reference:

- one fixpoint job
- one measurement job
- one road job
- one tunnel job
- one DTM job.

Since jobs are only referenced by a project, they may be used in more than one RoadRunner project, as well as in other applications. For example the same collection of control points may be used in two different projects.

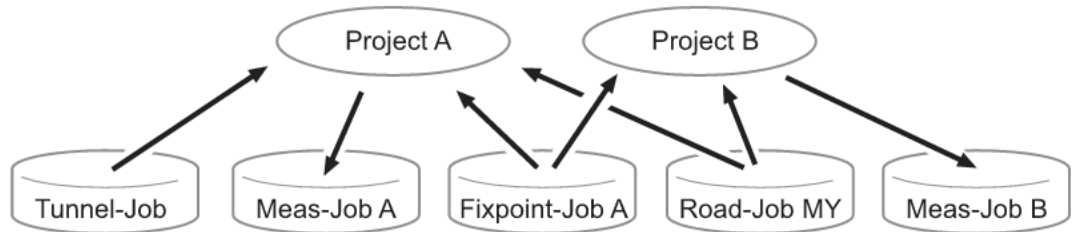

RRT12_027

Project A and Project B reference the same fixpoint job (**Fixpoint Job A**) and road job (**Road-Job MY**), however, their results are stored into different measurement jobs (**Meas-Job A**; **Meas-Job B**). In addition, Project A references the tunnel design data through a Tunnel Job (**Tunnel Job A**).

- Fixpoint job** The Fixpoint job holds all control point information needed in the field. For example, control points, points with known coordinates used for a TPS set-up.
- Measurement Job** The measurement job is where information generated in the field is recorded. All measurements, points and other values stored in the field are added to this job.
- Road Job** All road design information for road data outside of the tunnel, either typed in manually or exported from a design package is stored in the road job. Like the fixpoint job, it is a source of information. Refer to the RoadRunner Technical Reference Manual, chapter "6 Tunnel Job" for more information on road jobs.

Tunnel Job	Contains information relating to the design of the tunnel. The centre line of the tunnel and the tunnel design profiles are stored in the tunnel job. As with a road job, the tunnel job is a read-only source of information. Refer to chapter "6 Tunnel Job" of this manual for more information on tunnel jobs.
DTM Job	Holds DTM or TIN data (Digital Terrain Model; Triangular Irregular Network). Like a fixpoint job or road job, the DTM job is a source of information. Refer to the RoadRunner Technical Reference Manual, chapter 7 "DTM Job" for more information on DTM jobs.

The same job can be used as a data and measurement job.

Road jobs, Tunnel jobs and DTM jobs cannot be selected as a data or a measurement job. When selecting a job, a filter is applied to show only the relevant jobs in the selection list.

5.2

5.2.1

Overview

Selecting a Project

Overview

Upon starting the RoadRunner application, there are two different ways of selecting a project:

- **Select from list:**
Enter a list of projects stored on the CF Card or in the internal memory from the Road-Runner Setup panel.
 - **Resume:**
To resume the last task the project to which the task belongs to is selected automatically.
-

5.2.2

Browse for Existing Project

Browse for project

A list of all available projects in the internal memory or on the CompactFlash card will be opened when pressing **ENTER** on the Projects line of the RoadRunner Setup panel.

Projects (CF Card)	
Name	Date
Soccer	16.10.06
ELLIS	30.10.06
SAMPLE	17.10.06
RR_Exercise_3	31.03.04
RR_EXERCISE_2	31.03.04
RR_Exercise 5	30.03.04
Default Project	30.03.04

CONT NEW EDIT DEL MORE INTL

CONT (F1)

To select the highlighted project.

NEW (F2)

To create a new project. Refer to "5.3 Creating a New Project".

EDIT (F3)

To edit the highlighted project. This project also becomes the active project. Refer to "5.5 Editing a Project".

DEL (F4)

To delete the highlighted project. Refer to "5.4 Deleting a Project".

MORE (F5)

To toggle between Date and Time info.

CFCRD (F6) or INTL (F6)

To switch between the CompactFlash card and internal memory as the active device.

5.2.3

Resume task

Resuming the Last Task

RoadRunner retains the last active task used on any project. When the application is resumed, the last active task may be accessed again using the **RESUM (F4)** key. This avoids the selection of project, method and task to be staked out or checked every time the application is started.

```
RoadRunner Begin
Coord System : CS
CodeList : <None>

Config Set : TCRP
Reflector : Reflectorless
Add. Constant: 34.4 mm

CONT | CONF | SETUP | RESUM | CSYS
```

5.3 Creating a New Project

Create a project step-by-step

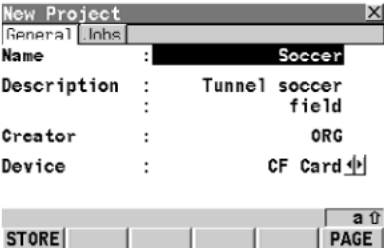
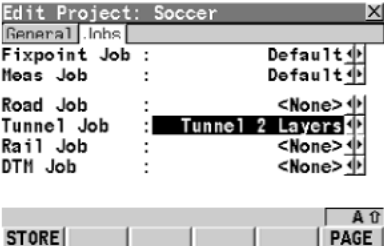
Step	Description
1.	 <p>Define the <Name:>, <Description:>, <Creator:> and <Device:> for the project. The <Name:> is mandatory.</p>
2.	<p>PAGE (F6) changes to the Jobs page.</p>
3.	 <p>Select the <Fixpoint Job:>, <Meas Job:>, <Road Job:>, <Tunnel Job:> and <DTM Job:> to be used in the new project. It is possible to add or remove jobs to the project at a later stage.</p>

Step	Description
4.	STORE (F1) to accept the changes and select the newly created project as the new active project.

5.4

Deleting a Project

General

Deleting a project will not delete the measurement job, fixpoint job, road job, tunnel job and DTM job that it references.

If two projects use the same control points by referencing the same fixpoint job, deleting one project will not delete the control points for the other project.

Deleting project step-by-step

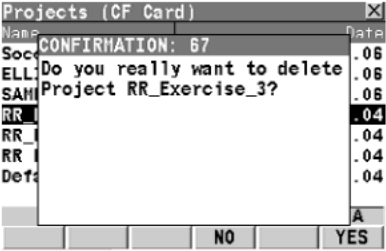
Step	Description
1.	Highlight the project to delete in the Projects panel.
2.	DEL (F4) to delete the project. 
3.	YES (F6) to confirm deletion, NO (F4) to return to the previous screen.
4.	CONT (F4) to return to the RoadRunner Start panel.

5.5

Editing a Project

General page

The project details contain general information about the project as well as the list of jobs referenced by the project. Project details may be edited using the EDIT (**F4**) key in the Projects panel.

Edit Project: Soccer				
General Inhs				
Name	:	Soccer		
Description	:	Tunnel soccer field		
Creator	:	ORG		
Device	:	CF Card		
STORE				A ↑
PAGE				

<Name:>

Project name, must be unique. This field is mandatory.

<Description:>

User input. Two line description of the project.

<Creator:>

User input. Name of the creator of the project.

<Device:>

CompactFlash Card or Internal Memory. The device on which the job is stored.

CONT (F1)

To accept changes and return to the screen from where this screen was accessed.

PAGE (F6)

changes to the Jobs page. All jobs referenced by the project are listed.

Job page

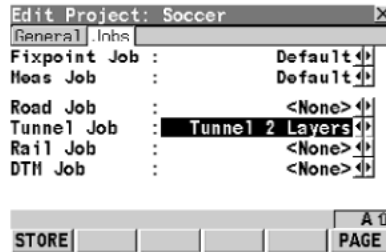

STORE (F1)

To accept the changes and return to the screen from where this screen was accessed.

<Fixpoint Job:>

The job that contains the point data to be used.

<Meas Job:>

The active job which also determines the coordinate system.

Points which are recorded during staking out or check are stored in this job.

<Road Job:>

The active road job.

<Tunnel Job:>

The active tunnel job.

<DTM Job:>

The active DTM job.

6

Tunnel Job

6.1

Overview

General

Each tunnel job consists of two major parts:

- **Design data:** Contains all the information about the tunnel design including the geometry of the centre line and the tunnel cross-section.
 - **Working tasks:** Tasks define how the design elements of the tunnel are staked out or checked in the field, they also define any offsets that should be applied to the design data. Refer to "6.3 Tasks" for more information on tasks.
-

6.2

6.2.1

Alignments

Design Data

Horizontal and Vertical Alignments

All tunnel jobs must consist of at least a horizontal and a vertical alignment. These data may be converted from a road design package using the Design To Field component within the Leica Geo Office application.

6.2.2**Design Profiles****Profiles**

Depending on the complexity of the tunnel job, the design data may vary from being a single horizontal and vertical alignment to a design containing many different design profiles with dozens of defined vertices.

Design profiles may be defined and edited in the Profile Editor application that is integrated into the LEICA Geo Office (LGO) application.

6.2.3

Layers

Layers

Tunnels generally consist of layers made of different materials, for example a shotcrete surface or a lining. At different times throughout a project it may be required to work with different layers of the tunnel.

RoadRunner allows the possibility of creating such layers by grouping together design profiles that will be used at the same chainage.

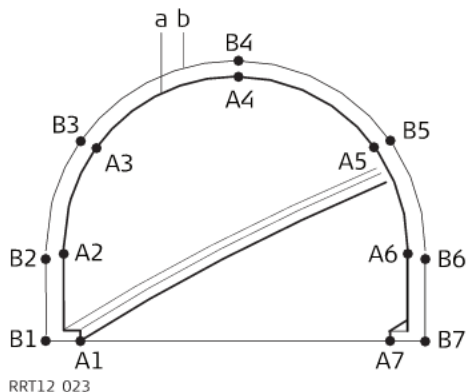

- The vertices **A1-A7** could be grouped together in a layer (**a**) and represent the final lining of the tunnel.
- The vertices **B1-B7** could be grouped together in a layer (**b**) and represent the inner shotcrete layer of the tunnel.

Design Profile Layers may be assigned to chainages along the centre line using the Profile Editor within LGO.

The layer of the tunnel to set out or check may be defined when creating a task.

6.3

Tasks

Overview

When staking out or checking a tunnel, it is often the case that it is not possible to finish a particular task in one go. RoadRunner Tunnel allows the possibility of storing the element to be staked out or checked together with all defined settings as a work task. Tasks are stored as a part of the project.

A task defines the offsets required for setting out and checking as well as the layer of the design profile to use and the chainage limits within which the task applies.

When pressing **CONT (F1)** on the RoadRunner Setup panel a list of available tasks will be shown.

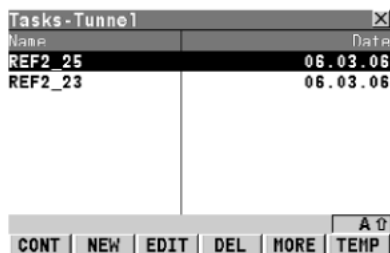

The screenshot shows a dialog box titled "Tasks - Tunnel" with a close button (X) in the top right corner. It contains a table with two columns: "Name" and "Date". The table lists two tasks: "REF2_25" and "REF2_23", both with a date of "06.03.06". Below the table is a control panel with buttons for "CONT", "NEW", "EDIT", "DEL", "MORE", and "TEMP". A small "A" icon with a double arrow is also visible in the top right of the control panel.

Name	Date
REF2_25	06.03.06
REF2_23	06.03.06

CONT NEW EDIT DEL MORE TEMP

CONT (F1)

Select the highlighted task and continue.

NEW (F2)

Create a new task.

EDIT (F3)

Modify selected task.

DEL (F4)

Delete selected task.

MORE (F5)

Toggle between Date and Time info.

TEMP (F6)

Create a new temporary task. The task is created in the same way as an ordinary task but the task is not saved.

6.3.1

Creating a New Task

Overview

The Selection Wizard-Start page defines the name of the task and whether shifts should be applied to the design data.

Shifts are applied temporarily to the design data for the defined task, the original design data is not modified when a shift is applied.



Creating a task step-by-step

Refer to chapter "6.3.2 Working with Shifts" for more information on applying shifts.

The same selection wizard is used for all tasks within the application.

The screenshot shows a dialog box titled "Selection Wizard-Start" with a close button (X) in the top right corner. It contains the following fields:

- Task Type : Tunnel (dropdown menu)
- Task Name : SHOTCRETE (text field)
- Shift Horiztl: None (dropdown menu)
- Shift Vertical: None (dropdown menu)
- Shift X-Sec : None (dropdown menu)

The screenshot shows a row of buttons. The first button is labeled "NEXT" and is highlighted. To its right are four empty buttons. In the top right corner of the row, there is a small box containing the text "A 0".

NEXT (F1)

Move on to the next page of the selection wizard.

The second page of the selection wizard defines the layer of the design profile to be used for the task.

**NEXT (F1)**

Move on to the next page of the selection wizard.

BACK (F6)

Go back to the previous page of the selection wizard.

The next page of the wizard displays the horizontal alignment. Given that this is the only stringline available in a tunnel job, this page is purely informative.

**NEXT (F1)**

Move on to the next page of the selection wizard.

BACK (F6)

Go back to the previous page of the selection wizard.

This page of the selection wizard defines whether the task should only be applied to a limited section of the alignment. If the defined chainage range is exceeded during stake out/check a warning appears.

Selection Wizard-Define X
Centre line : Centreline
Use Min/Max : Yes ↓
Min Chainage : 100.000 ■
Max Chainage : 285.746 ■

				A ↑
FINSH			DEFLT	BACK

FINSH (F1)

Finish the selection wizard and return to the task selection page.

DEFLT (F5)

Set the chainage limits to the maximum and minimum chainage available in the tunnel job.

BACK (F6)

Go back to the previous page of the selection wizard.

6.3.2**Working with Shifts**

Overview

If a shift is defined on the first page of the selection wizard, the parameters associated with the shift must be entered after defining the chainage limits.

Two types of shifts may be applied:

- Constant or
- linear.

The application of the shift is dependent upon to which entity it should be applied:

- Horizontal alignment,
- Vertical alignment or
- Design Profile.



Refer to chapter "1.4 Shifts" for more information on the type of shift for each entity.

For linear shifts

The parameters required for applying the shift are identical for all entities.

```
Selection Wizard-Shift [X]
Shift Type : Horiz- Linear
Beg Chainage : 100.000 m
Beg Shift : 0.000 m
End Chainage : 285.746 m
End Shift : 0.500 m
```

```
          A [↑]
NEXT | | | | | BACK
```

Beg Chainage

Chainage from which the shift should be applied.

Beg Shift

Magnitude of the shift to apply at the begin chainage.

End Chainage

Chainage at which the shift should end.

End Shift

Magnitude of the shift to apply at the end chainage.

For constant shifts

```
Selection Wizard-Shift [X]
Shift Type : Vert- Constant
Beg Chainage : 100.000 m
Beg Shift : 0.100 m
End Chainage : 285.746 m
```

```
          A [↑]
FINSH | | | | | BACK
```

Beg Chainage

Chainage from which the shift should be applied.

Beg Shift

Magnitude of the shift to apply.

End Chainage

Chainage at which the shift should end.

6.4

6.4.1

Viewing and Editing

Viewing and Editing the Design Data

Overview

The design data stored within the tunnel job contains all of the information about the tunnel design. This includes the stringlines and layers (for example, the geometry of the centre line or the layers of the different materials/surfaces which form the tunnel). The design data can be viewed and partially edited in these View and Edit screens.

View&Edit Data

Job Name : Tunnel 2 Layers

Layer : Final Layer

#Profiles : 2

Centre line : Centreline

Chainage : 100.000

Ch Increment : 10.000

CONT EDIT VIEW a

CONT (F1)

To return to the RoadRunner Tunnel Setup screen.

EDIT (F3)

To edit the following design data:

- 1) to edit the general job details,
- 2) to change the start chainage of the centre line of the selected layer.

VIEW (F4)

To view the following design data in a selected layer:

- 1) to view specific details of the layer centre line,
- 2) to view cross-section plots.

Field	Description of field
Job Name	The name of the active tunnel job, as defined in the project.
Layer	To select a layer from the active tunnel job. All of the layers within the active tunnel job can be selected.
#Profiles	The number of profiles from the selected layer.
Centre line	The name of the layer centre line.
Chainage	To enter a start chainage to use when viewing the data. The default value is the start chainage of the layer centre line.

Field	Description of field
Ch Increment	To enter a chainage increment to use when stepping through the data
	If a centre line has not been defined, a start chainage cannot be entered and the field will be shown as "----". If a centre line has not been defined, a chainage increment cannot be entered and the field will be shown as "----".

6.4.2

Viewing details of the layer centre line

Viewing the Design Data

This page shows the following:

Geometrical details of the selected stringline at the selected chainage.

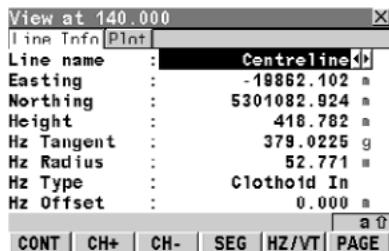

View at 140.000	
Line Infn	Print
Line name	: Centreline
Easting	: -18862.102
Northing	: 5301082.924
Height	: 418.782
Hz Tangent	: 379.0225
Hz Radius	: 52.771
Hz Type	: Clothoid In
Hz Offset	: 0.000

Buttons: CONT CH+ CH- SEG HZ/VT PAGE

CONT (F1)

To return to the View&Edit Data screen.

CH+ (F2)

To increase the chainage by the chainage increment, as defined in the View&Edit Data screen.

CH- (F3)

To decrease the chainage by the chainage increment, as defined in the View&Edit Data screen.

SEG (F4)

To enter the Segment Info screen.

HZ/VT (F5)

To toggle between the vertical alignment data and the horizontal alignment data.

PAGE (F6)

To move to the next page.

Field	Description of field
Line name	To select a stringline from the layer.
Easting	The East coordinate of the stringline.
Northing	The North coordinate of the stringline..
Height	The height of the stringline.
The following fields/values can be toggled, by using the HZ/VT (F5) softkey:	
Hz Tangent/Grade	The tangent direction or grade of the stringline.
Hz/Vt Radius	The horizontal/vertical radius of the stringline segment.

Field	Description of field
Hz/Vt Type	The horizontal/vertical segment type.
Hz/Vt Offset	The horizontal/vertical offset to the layer centre line.
 If a value has not been defined, the field will be shown as "----".	

Viewing profiles

This page shows the following:

A cross section view of the design data at the selected chainage. No selection or zoom/pan functionality is available.

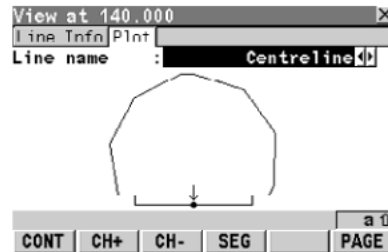

CONT (F1)

To return to the View&Edit Data screen.

CH+ (F2)

To increase the chainage by the chainage increment, as defined in the View&Edit Data screen.

CH-1 (F3)

To decrease the chainage by the chainage increment, as defined in the View&Edit Data screen.

SEG (F4)

To enter the Segment Info screen.

PAGE (F6)

To move to the next page.

Viewing the segment: the Hz Alignment page

This page shows the following:

Detailed horizontal alignment information about the current stringline segment.

Segment Info - Start Point	
Hz Alignment	Vt Alignment
Line name	: Centreline
Chainage	: 132.894 m
Easting	: -19859.504 m
Northing	: 5301076.311 m
Height	: 418.963 m
Hz Tangent	: 374.7382 y
Hz Radius	: 1000000.000 m
Hz Type	: Clothoid In
a u	
CONT	SEG+
SEG-	ENDP
PAGE	

CONT (F1)

To return to the View screens.

SEG+ (F2)

To move to the next segment.

SEG- (F3)

To move to the previous segment.

ENDP/STRTP (F4)

To toggle between the start point and the end point of the segment.

PAGE (F6)

To move to the next page.

Field	Description of field
Line Name	The name of the selected stringline.
The following fields/values can be toggled, by using the ENDP/STRTP (F4) softkey:	
Chainage	The chainage of start/end point of the segment.
Easting	The East coordinate of the start/end point of the segment.
Northing	The North coordinate of the start/end point of the segment.
Height	The height of the start/end point of the segment.
Hz Tangent	The tangent direction at the start/end point of the segment.
Hz Radius	The radius at the start/end point of the segment (is not toggled).
Hz Type	The current segment type (is not toggled).
	If a value has not been defined, the field will be shown as "----".

Viewing the segment: the Vz Alignment page

This page shows the following:

Detailed vertical alignment information about the current stringline segment.

Segment Info - Start Point				
Hz Alignment	Vt Alignment			
Line name :	Centreline			
Chainage :	127.442 m			
Easting :	-19857.397 m			
Northing :	5301071.283 m			
Height :	419.002 m			
Grade :	1:0 hv			
Vt Radius :	341.137 m			
Vt Type :	Circle/Arc			
a 0				
CONT	SEG+	SEG-	ENDP	PAGE

CONT (F1)

To return to the View screens.

SEG+ (F2)

To move to the next segment.

SEG- (F3)

To move to the previous segment.

ENDP/STRTP (F4)

To toggle between the start point and the end point of the segment.

PAGE (F6)

To move to the next page.

Field	Description of field
Line Name	The name of the selected stringline.
The following fields/values can be toggled, by using the ENDP/STRTP (F4) softkey:	
Chainage	The chainage of start/end point of the segment.
Easting	The East coordinate of the start/end point of the segment.
Northing	The North coordinate of the start/end point of the segment.
Height	The height of the start/end point of the segment.
Grade	The grade at the start/end poin of the segment (is not toggled).
Vt Radius	The radius at the start/end point of the segment (is not toggled).
Vt Type	The current segment type (is not toggled).
	If a value has not been defined, the field will be shown as "----".

6.4.3

Editing the Design Data

Editing the job details

```

Edit: Tunnel 2 Layers
Inh Centreline
Name      : Tunnel 2 Layers
Description :
          :
Creator   : --Core Developme
Device    : CF Card
  
```

STORE (F1)

To return to the View&Edit Data screen.

PAGE (F6)

To move to the next page.

Field	Description of field
Name	The unique name of the tunnel job. The name may be up to 16 characters long and may include spaces. This field is mandatory.
Description	A detailed description of the tunnel job (two lines are available). This field is optional.
Creator	The name of the person who created the tunnel job. This field is optional.
Device	CF Card or Internal Memory. The device on which the tunnel job is stored.

Changing the start chainage of the centre line of the selected layer

```

Edit: Final Layer
Inh Centreline
Centreline : Centreline
StartChainage: 100.000
End Chainage : 285.746
  
```

STORE (F1)

To store data and return to the View&Edit Data screen.

RESET (F4)

To clear all changes made to the start chainage reset to the original start chainage.

PAGE (F6)

To move to the next page.

Field	Description of field
Centreline	The name of the centre line.
StartChainage	To enter a start chainage for the layer centre line. By using the centre line length, the end chainage is automatically calculated.
End Chainage	The end chainage of the layer centre line, as calculated from the start chainage.

7

Configuration

7.1

Overview

Three parts of configuration

The configuration of the RoadRunner application is divided into three parts:

- Project Configuration
- Road Configuration
- Tunnel Configuration
- Rail Configuration

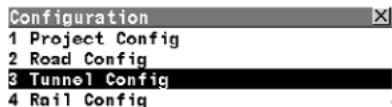

A screenshot of a configuration menu window titled "Configuration" with a close button (X) in the top right corner. The menu lists four options: "1 Project Config", "2 Road Config", "3 Tunnel Config", and "4 Rail Config". The "3 Tunnel Config" option is highlighted with a black background.



A screenshot of a menu bar with a "CONT" label on the left and a "A" label on the right. Below the "CONT" label are five empty rectangular boxes, and below the "A" label is one empty rectangular box.

Project and Road Configuration



The values in the **Project Configuration** are general parameters that apply to both Road and Tunnel projects. The values set in the **Road Configuration** apply only to Road projects and the values set in the **Tunnel Configuration** apply only to Tunnel projects.

For more information on the Project and Road Configuration, refer to the RoadRunner Technical Reference Manual.

Tunnel Configuration

The Tunnel Configuration consists of five pages where parameters relating to the configuration of the application may be modified. Refer to chapter "7.2 Tunnel Configuration General Page".

7.2

Tunnel Configuration General Page

General Settings

The **General** page allows parameters that will be used throughout the application to be set.

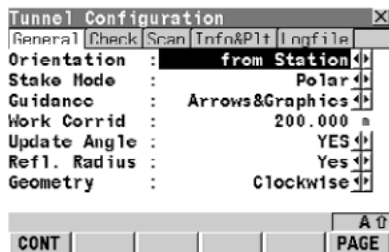

CONT (F1)

To confirm the changes and move to the previous screen.

PAGE (F6)

To go to the next page of the configuration.

Orientation

The reference direction used to stake out points. The stake out elements and the graphics displayed are based on this selection:

To Alignment: The position of the measured point and the calculated differences are displayed relative to the alignment.

To Station: The position of the measured point and the calculated differences are displayed relative to the position of somebody located at the measured point looking towards the sensor.

From Station: The position of the measured point and the calculated differences are displayed relative to the position of somebody located at the sensor looking towards the measured point.

Stake Mode

If the option **To Station** or **From Station** is used, the displayed differences between the measured point and the design point may be configured:

Orthogonal: The differences are displayed as two orthogonal distances left/right and forward/back with respect to the line of sight.

Polar: The differences are displayed as polar coordinates, angle and distance, with respect to the line of sight.

Guidance

Indication of direction and distance from measured point to point to set out:

Off: No graphical guidance is used, only numerical values are available on the screen.

Polar: Forward/Back and Left/Right arrows are shown on the screen.

Graphics: A bulls-eye is shown on the screen.

Arrows&Graphics: Forward/Back and Left/Right arrows and a bulls-eye are shown on the screen.

Work Corridor

Working corridor of tunnel job. If a measured point is further away from the working corridor distance, an error message is displayed.

Update Angle

Update of vertical angle after a distance measurement.

Yes: The measured point will be projected by a distance equivalent to the radius of the reflector in a direction perpendicular to the tangent of the design profile.

No: Angles and stake out values are updated only after a distance measurement. All values are then frozen until the next distance is taken.

Refl. Radius

When using a reflector to check a design profile it is important to take into account the reflector radius parameter in the **General** page of the application configuration.

Yes:

The measured point will be projected by a distance equivalent to the radius of the reflector in a direction perpendicular to the tangent of the design profile.

No:

The design profile will be compared to the coordinates of the centre of the reflector at the measured position.

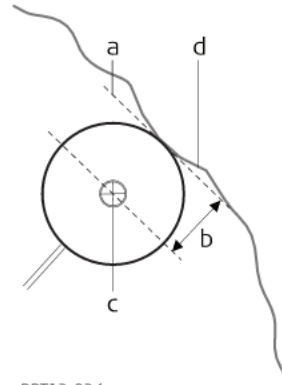

RRT12_024

- a) Tangent to design profile
- b) Reflector radius
- c) Reflector
- d) Design profile

If reflectorless measurements are used or no design profile has been defined, the reflector radius parameter will not be used in the calculation.

Geometry

Defines the sense in which the design profile is considered.

Clockwise: The design profile is defined in a clockwise direction. The number of each element also increments in a clockwise direction.

CounterClockwise: The design profile is defined in a counter-clockwise direction. The number of each element also increments in a counter-clockwise direction.

7.3

Tunnel Configuration Check Page

Check configuration

The **Check** page allows parameters that will be used during Tunnel Check to be set.

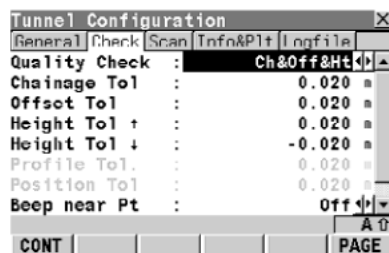

CONT (F1)

To confirm the changes and move to the previous screen.

PAGE (F6)

To go to the next page of the configuration.

Quality Check	Activates a position check when storing a staked or checked point. When the defined tolerance is exceeded, the stake out/check can be repeated, skipped or stored. Depending on this selection the lines below are enabled/disabled. NONE No quality check during stake out/check of points. Ch&Off&Ht Check for chainage, horizontal offset and height. Ch&Off Check for chainage and horizontal offset. Pos&Ht Check for 2D position and height. Position Check for 2D position. Height Check for height. Profile Check for distance from design profile.
Chainage Tol	From 0.001 to 100 maximum permitted difference in chainage.
Offset Tol	From 0.001 to 100 maximum permitted horizontal offset from defined position.
Height Tol	From 0.001 to 100 maximum permitted height difference.
Profile Tol	From 0.001 to 100 maximum permitted distance from design profile.
Position Tol	From 0.001 to 100 maximum permitted radial horizontal distance.
Beep near Pt	On or Off activates an acoustic warning signal when the horizontal radial distance from the current position to the point to stake out is equal or less than defined in Dist from Pt
Dist from Pt	Available when Beep near Pt: On is selected. Defines the horizontal radial distance from the current position to the point to stake out within which the acoustic warning signal is active.

7.4

Tunnel Configuration Scan Page

Scan configuration

The **Scan** page allows parameters that will be used when scanning profiles to be set.

The screenshot shows a window titled "Tunnel Configuration" with a close button (X) in the top right corner. Below the title bar are four tabs: "General", "Check", "Scan", and "InfoAPI", with "Scan" being the active tab. The main area contains the following configuration parameters:

Scan Mode	:	Vertical	↕
Rotn.Method	:	Distance	↕
Chain.Limit	:	0.050	■
Max.Iterations	:	3	↕
Tight Behav.	:	Store OnlyValid	↕
Tight Toleran	:	0.500	■
Tight Ignore	:	2.000	■

At the bottom of the window, there are two buttons: "CONT" and "PAGE". The "PAGE" button has a small "A" icon above it.

CONT (F1)

To confirm the changes and move to the previous screen.

PAGE (F6)

To go to the next page of the configuration.

Scan Mode	Indicates the type of profile to be scanned. At the present time the available modes are the measurement of vertical and tilted profiles.
Rotation method	Defines how the distance between points is defined. At the present time, the only available method is By distance .
Chain.Limit	Defines the maximum difference between the measured and defined chainage within which a point will be recorded.
Max.Iterations	The maximum number of attempts that should be made in measuring a point when measuring parallel profiles.
Tight Behav.	Defines the behaviour of the application when a measured point is outside of the defined Tight Tolerance . StoreAll: Store all measurements independent of whether they are within tolerance. Store OnlyValid: Store only the points that are within tolerance. Pause & Store: Store all measurements but if the point is out of tolerance, pause the scan. Pause: Pause the application if a point is out of tolerance.
Tight Toleran	Refers to the maximum permitted distance between the measured point from the design profile. If the distance between the measured point and the design profile is greater than the tight tolerance and less than the tight ignore value, the application will perform the action defined as the tight behaviour
Tight Ignore	If the distance between the measured point and the design profile is greater than the Tight Ignore value, the measurement will be ignored and the values will not be stored.

For more information about Thight Tolerance refer to chapter "1.3.2 Tunnel Profiles".



7.5

Tunnel Configuration Info and Plot Page

Overview

The **Info & Plot** page allows the definition of the parameters to be seen on the Info page whilst working with the application. It also allows the parameters to be used for plotting functions to be defined.

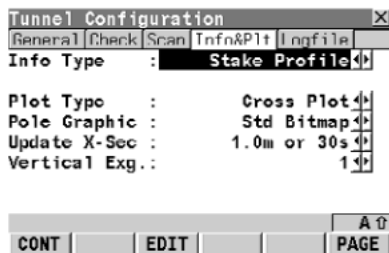

CONT (F1)

To confirm the changes and move to the previous screen.

EDIT (F3)

Edit parameters of current info page type. Refer to "7.5.1 Defining the Info Page Display" for more details.

PAGE (F6)

To go to the next page of the configuration.

Info Type

Defines the parameters to view on the Info page of the application. Different combinations of the parameters to view may be stored for the four main functions of the application: **Stake Face**, **Stake Profile**, **Check Profile**, **Scan Profile**.



For more information on the parameters that may be selected, refer to chapter "7.5.1 Defining the Info Page Display"

Plot configuration	Plot Type:	Defines the type of plot to be viewed on the Plot page.
		Cross Plot: View measured point with respect to design profile.
		Plan View: View position of measured point with respect to horizontal alignment.
		Profile View: View position of measured point with respect to vertical alignment.
	Pole Graphic:	Defines the graphical representation of the measured point on the plot page.
		Std Bitmap: Standard bitmap image of a reflector and pole.
		Actual Height: Reflector pole is not shown and position of reflector denotes the actual measured position.
	Update X-Sec:	Update frequency of the cross section view on the Plot page when working in tracking mode.
		0.5m or 2s: Update the plot every 2 seconds or when the measured point is more than 0.5 m from the previous plotted point.
		0.5m or 10s: Update the plot every 10 seconds or when the measured point is more than 0.5 m from the previous plotted point.
1.0m or 30s: Update the plot every 30 seconds or when the measured point is more than 1 metre from the previous plotted point.		
5.0m or 1m: Update the plot every 60 seconds or when the measured point is more than 5 metres from the previous plotted point.		

Vertical Exg.:

Vertical exaggeration for cross section plots.

(Vertical plot scale relative to horizontal.)

0.5: Ratio of vertical to horizontal scale 1:2

1: Ratio of vertical to horizontal scale 1:1

2: Ratio of vertical to horizontal scale 2:1

5: Ratio of vertical to horizontal scale 5:1

10: Ratio of vertical to horizontal scale 10:1

7.5.1

Defining the Info Page Display

Overview

The **Define Info Display** page allows the parameters to view on the **Info** page of the application to be defined. Different combinations of the parameters to view may be stored for the four main functions of the application:

Stake Face, Stake Profile, Check Profile, Scan Profile.

The process for defining each of these combinations is identical. The user defines which parameter should be viewed on each line. Up to 16 lines of parameters may be defined although a maximum of 9 lines may be viewed at any one time.



Selecting the parameters

It is necessary to scroll with the arrow keys to view additional lines.

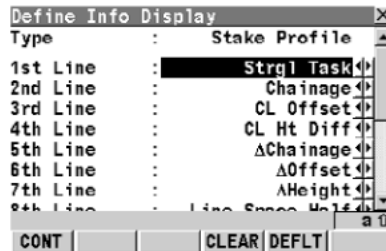
**CONT (F1)**

Confirm the changes and move to the previous screen.

CLEAR (F4)

Clear all parameters from all lines.

DEFLT (F5)

Set the default value for all lines.

To modify the selection on any particular line, place the cursor on the line to modify using the arrow keys and press the **ENTER** key.

Use the arrow keys to select the required parameter and press the **ENTER** key to confirm the choice. It is also possible to search for a parameter by entering the first character of the parameter name.

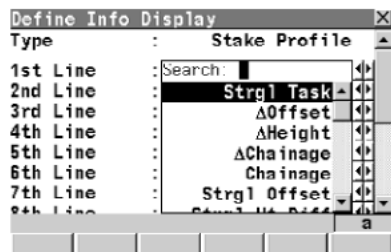

Available parameters

The following parameters are available in the Define Info Display:

Strgl Task:	Name of the current task.
ΔOffset:	Distance from the measured point to the point to set out in a direction perpendicular to the horizontal alignment.
ΔHeight:	Height difference between the measured point and the point to set out.
ΔChainage:	Chainage difference between the measured point and the point to set out.
Chainage:	Chainage of the measured point.
Strgl Offset:	Distance between the measured point and the shifted horizontal alignment when a shift is used.
Strgl Ht Diff:	Height difference between the measured point and the shifted vertical alignment when a shift is used.
Strgl Name:	Name of the centreline.
CL Ht Diff:	Height difference between the measured point and the height of the vertical alignment at the same chainage.
CL Height:	Height of the vertical alignment at the chainage of the measured point.
CL Radius:	Radius of the horizontal alignment at the at the chainage of the measured point.
CL Type:	Curve type of the horizontal alignment at the chainage of the measured point.
CL Offset:	Distance between the measured point and the horizontal alignment in a direction perpendicular to the horizontal alignment.
CL Tangent:	Direction of the tangent to the horizontal alignment at the at the chainage of the measured point.
Near Tang Pt:	Distance along the horizontal alignment from the measured point to the nearest tangent point.
CL Grade:	Grade of the vertical alignment at the chainage of the measured point.

Dirc to Point:	Direction from the point to the point to set out.
Dist to Point:	Distance from the point to the point to set out.
Def Easting:	Easting of the point to set out.
Def Northing:	Northing of the point to set out.
Def Height:	Height of the point to set out.
Act Easting:	Easting of the measured point.
Act Northing:	Northing of the measured point.
Act Height:	Height of the measured point.
Quality 3D:	Standard deviation of the point measurement.
Line Space	
Half/Full	
Prof.Offset:	Distance from the design profile to the measured point.
Prof.N^oElement:	Element number of the closest design profile element to the measured point.
Prof.Element(%):	Distance in percentage terms of the measured point along the design profile element.
DistAlongProf:	Distance of the measured point along the design profile.
Vert Chainage:	Chainage of the measured point projected perpendicular to the vertical component of the centreline.
Vert Sqr Off:	Offset perpendicular to the vertical component of the centreline.

7.6

Tunnel Configuration Logfile Page

Logfile settings

The **Logfile** page allows the user to define the name and format of any logfile that should be written. Data is recorded to the logfile each time a data is recorded to the database. The format of the logfile is determined by the selected format file. Format files may be defined in the Format Manager component of the Leica Geo Office application.

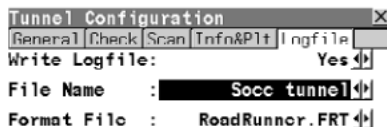
**CONT (F1)**

To confirm the changes and move to the previous screen.

PAGE (F6)

To go to the next page of the configuration.

Write Logfile:

Defines whether a logfile should be written or not.

File Name:

Name of logfile to be written. Logfiles are stored in the folder named DATA on the CompactFlash card.

Format File:

Format file to use when writing the logfile.

Index

- A**
- Act Easting 133
 - Act Height 133
 - Act Northing 133
 - Alignment 58
 - ALL 7, 39
 - Angular 48
 - Arrows&Graphics 119
- B**
- Back Interval 45
 - Back interval 45
 - Bailout 14
 - Beep near Pt 124
 - Begin panel 29
 - Breakpoint 52
- C**
- Centre Line 10
 - CL Grade 132
 - CL Height 132
 - CL Ht Diff 132
 - CL Offset 132
 - CL Radius 132
 - CL Tangent 132
 - CL Type 132
 - CH+1 76
 - Ch.Increment 76
 - Chain.Limit 55, 126
 - Chainage 6, 132
 - Chainage Tol 124
 - Check 6
 - Check Ht Diff 38
 - Check Offset 38
 - Check Profile 34
 - Clockwise 69
 - CompactFlash card 27
 - Constant 18
 - CONT 88
 - Control points 84
 - Converters 22
 - CounterClockwise 69
 - CProf.NºElement 133
 - Create
 - Create 90
 - Creating a New Project 90
 - Creating a new task 101
 - Cross Plot 128

D	
DBX	27
Define	
DChainage	132
Def Chainage	76
Def Easting	133
Def Height	133
Def Northing	133
Define	65
DEL	88
Deleting a Project	92
DHeight	132
Digital Terrain Model	86
Digital Terrain Models	84
Dirc to Point	133
Discrete points	52
Distance	
DIST	7, 39
Dist from Pt	124
Dist to Point	133
DistAlongProf	133
Distance	12, 45
DOffset	132
Downloads	22
DTM job	84
E	
EDIT	88
Editing a project	94
Element	69
Element&Offset	69, 79
End point	48
Error message	47
Exclude limit	49
Existing	88
F	
Face	6
Fixpoint job	84
Format	134
Format file	134
Format Manager	134
Forward	45
From Station	119
Fwd Distance	45
Fwd Interval	45
G	
General panel	47, 66
GET B	47
GET F	47
Graphics	119
Guidance	119

H

Height Tol	124
Horizontal	58

I

Include limit	49
Info Panel	71
Info Type	127
Info&Plot	39
Input Method	76
Iteration	61

J

Job	67
Jobs	84

L

LandXML	6
Layers	99
Licence key	28
Limits	48
Linear	18
Logfile	134

M

Main menu	6
Max.Iterations	55, 126
Measurement job	84
MORE	88

N

Near Tang Pt	132
NEW	88

O

Off	119
Offset Tol	124
Offset&Height	66, 77
Offsets	11
Option	58
Orientation	119
Orthogonal	119
Overbreak	10
Overlapping zones	49

P

PAGE	7, 39
PAUSE	53
Perpendicular	18
Plan View	128
Plane	48
Plot	41
Plot Type	128
Plumb line	18
Point ID	38, 76
Polar	119
Pole Graphic	128
Portal	10
POSIT	69
Position Tol	124

Profile	
Prof.Element(%)	133
Prof.Offset	133
ProfDist&Offset	68, 78
Profile	6, 45, 124
Profile Chain	45
Profile Tol	124
Profile View	128
Project Configuration	116
Q	
Quality 3D	133
Quality Check	124
R	
Rail Configuration	116
REC	7, 39
Reflector	
Refl Radius	121
Reflector Ht	38
reflector radius	41
Reflectorless	41
RESUM	89
Road Configuration	116
Road job	84
RoadRunner Tunnel Setup panel.	34
Rotation method	55, 126
Rotation Point	10

S	
Scan	15, 46
Scan Mode	55, 126
Scan Profile	34
Selection	102
Set out	58
Shifts	17
Sign convention	19
Stake	
Stake	6
Stake Height	77
Stake Height Difference	67
Stake Mode	119
Stake Offset	67
Stake Pt ID	67, 77
Starting point	48
STOP	53
Strgl Ht Diff	132
Strgl Name	132
Strgl Offset	132
Strgl Task	132
Stringline	102
Superelevation	10

T		Z	
Tangent	41	Zone	48
Tight Behav.	126		
Tight Ignore	126		
Tight Toleran	126		
Tight tolerance	14		
To Alignment	119		
To Station	119		
Triangular Irregular Network	86		
Tunnel			
Tunnel Centreline	23		
Tunnel Configuration	116		
Tunnel Job	34, 84		
Tunnel Profile Editor	24		
Layer details view	26		
Profile details view	25		
U			
Underbreak	10		
Update Angle	120		
Update X-Sec	128		
V			
Vertical	58		
Vertical exaggeration	129		
W			
Work Corridor	120		
Working with shifts	104		

Total Quality Management: Our commitment to total customer satisfaction.



Leica Geosystems AG, Heerbrugg, Switzerland, has been certified as being equipped with a quality system which meets the International Standards of Quality Management and Quality Systems (ISO standard 9001) and Environmental Management Systems (ISO standard 14001).

Ask your local Leica Geosystems dealer for more information about our TQM program.

Leica Geosystems AG
Heinrich-Wild-Strasse
CH-9435 Heerbrugg
Switzerland
Phone +41 71 727 31 31
www.leica-geosystems.com

- when it has to be **right**

Leica
Geosystems