

Torflex Axle Order Form

Please complete the form, sign, and **fax to 612-331-4159** to order the axle. **Special orders are non-returnable.**

Quantity: _____ Capacity: _____ Axle Serial Number: _____

Frame to Frame: _____ Hub Face: _____

Track: _____ (If duals are used)

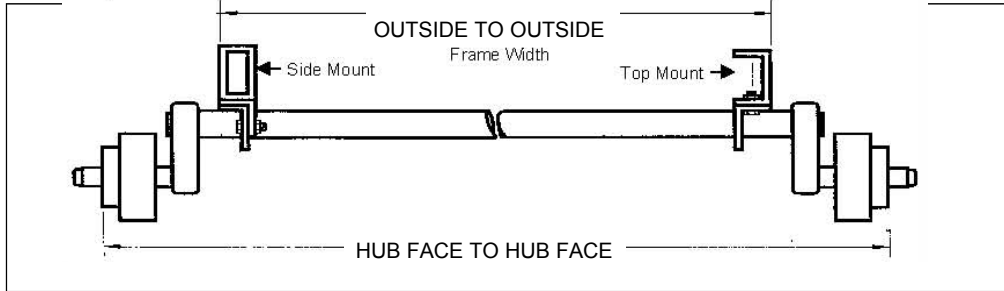

Single Tandem Triple **(circle one)**

Tire Size: _____ IE. 225/80R15

Starting Angle: _____

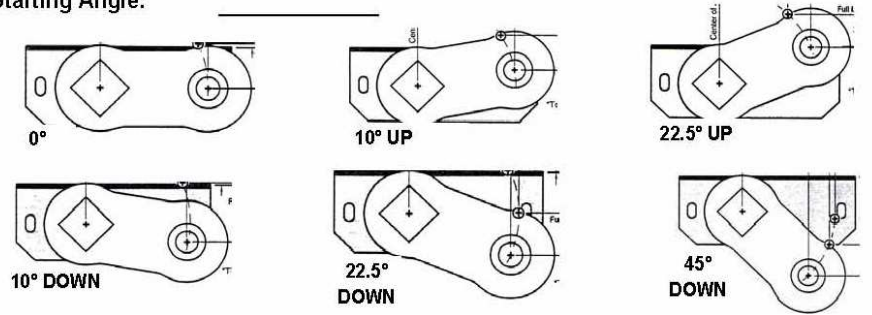

Bracket Mounting

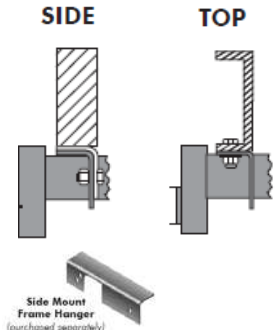

Bracket Orientation

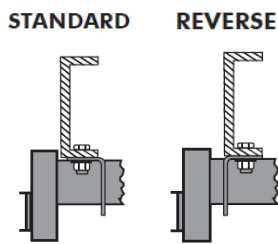

Bracket Profile

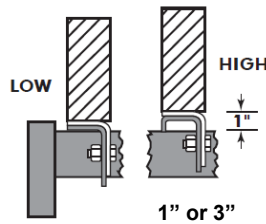

Hub Type: Grease Oil Bath EZ Lube™ Nev-R-Lube™ (circle one)

Brake Type: Electric: Nev-R-Adjust™ Manual Adj (circle one)

Hydraulic: Duo-Servo Uni-Servo (surge) (circle one)

Idler

Wheel Bolt Pattern: _____ Stud Size: 1/2 - 9/16 - 5/8 (circle one)

Attaching Kit: Top Mount Side Mount (circle one)

Special Features: _____
(other than above)

Date: _____ Account # _____

Account Name: _____

Address: _____

City: _____

State: _____ Zip: _____

Contact Person: _____

Email Address: _____

Phone #: _____ Fax #: _____

I verify that the axles indicated above are correct, that Dexter is allowed a 1/4" plus or minus tolerance on these measurements, *that all upgrades I need are listed above*, that non-refundable deposits may be required or forfeited if axles are not picked up in 30 days and that axles are not returnable.

Signature: _____

MADISON WAREHOUSE
1206 Femrite Dr. • Madison, WI 53716
(608) 222-4545
To Call Madison Toll Free
800-999-3394
Fax 608-222-8843

MINNEAPOLIS WAREHOUSE
2500 Kennedy St. N.E. • Mpls., MN 55413
(612) 331-1311
To Call Minneapolis Toll Free
800-888-1358
Fax 612-331-4159

FARGO WAREHOUSE
3453 7th Ave N.W. • Fargo, ND 58102
(701) 476-0600
To Call Fargo Toll Free
800-666-1670
Fax 701-476-0683

Salesperson

Salesperson

Salesperson

Return to: **PIONEER RIM & WHEEL CO**