

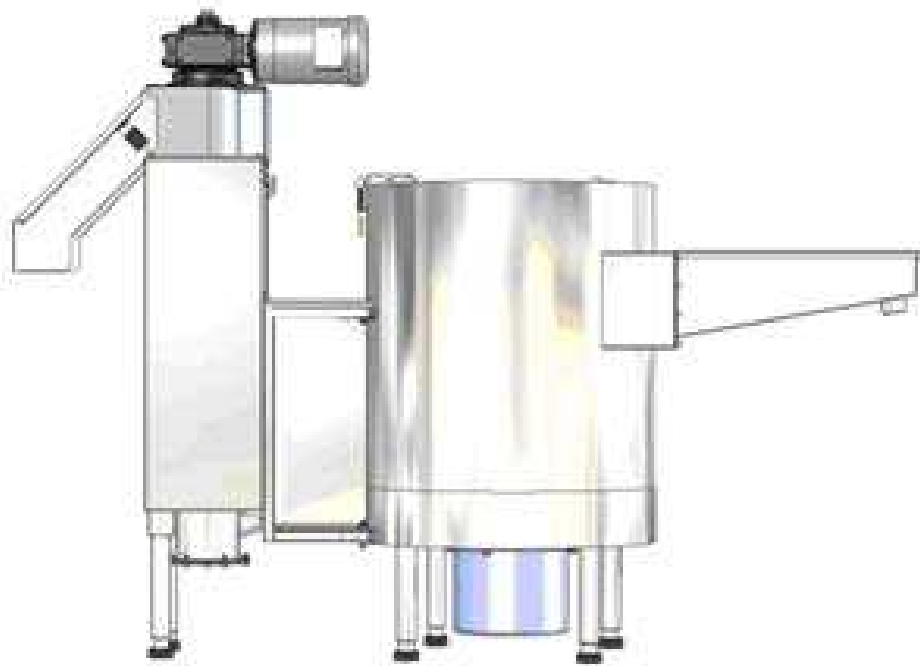

Operation/Service Manual

SPC-75s Close Coupled Pulping System





To better serve your needs in the future, please record your equipments information below.

Model Number: SPC-75	Serial Number:
Service Company:	Service Phone Number:
Rep/ Dealer:	Rep/Dealer Phone Number:
Somat Service Dept: 800-237-6628 x 176	
Somat Parts Dept: 800-237-6628 x 133	parts@somatcompany.com

To expedite service or parts, please have the above information available before you call. The serial number of your machine is located inside of the main electrical control panel for your Somat equipment.



SOMAT COMPANY LIMITED WARRANTY

SOMAT COMPANY warrants each new product manufactured by it to be free from defects in material and workmanship under normal use and service, which does not include normal wear of parts, ("normal use and service", with respect to Pulpers, Presses, water Hydra-Extractors, Waste Handling and Processing Systems, shall mean the handling only of waste items of the types listed in the SOMAT® Quotation or Sales Order therefore and within the **LIMITATIONS THEREIN** set forth), its obligation under this warranty being limited to repairing or replacing any part or parts thereof, free of charge **INCLUSIVE** of labor to remove and replace, f.o.b. factory from which shipped, which shall, within one year from initial start-up of the SOMAT® System or from date of original installation of the product if not a system be returned to SOMAT® at the factory from which shipped, with transportation charges prepaid, and which SOMAT's examination shall disclose to its satisfaction to have been thus defective. This warranty shall not apply to any product or part which shall have been repaired or altered by any person not employed or retained by SOMAT®, so as in the judgment of SOMAT® to affect its operation and reliability, nor which has been installed, operated, or maintained contrary to SOMAT® OPERATION or PREVENTIVE MAINTENANCE INSTRUCTION MANUALS or to other written instructions or drawings approved by SOMAT®, nor which has been subject to misuse, negligence, or accident. This warranty shall not apply should the SOMAT® System be initially started up without a duly authorized SOMAT® representative present.

EXCEPT AS HEREIN EXPRESSLY STATED, NO WARRANTY, EXPRESS, IMPLIED OR BY LAW, (INCLUDING BUT NOT LIMITED TO ANY IMPLIED WARRANTY OF MERCHANTABILITY OR FITNESS FOR A PARTICULAR PURPOSE), IS MADE BY SOMAT; AND IN ANY EVENT SOMAT'S LIABILITY, WHETHER IN CONTRACT, TORT, STRICT LIABILITY, OR UNDER ANY WARRANTY, OR OTHERWISE, SHALL NOT EXCEED THE PURCHASE PRICE RECEIVED BY IT AND SHALL IN NO EVENT INCLUDE ANY CONSEQUENTIAL, INCIDENTAL, PUNITIVE OR OTHER SPECIAL DAMAGES.

NO CHANGE IN THIS WARRANTY AND LIMITATION OF LIABILITY AND NO SUBSTITUTE THEREFORE (WHETHER INCORPORATED IN A PURCHASE ORDER OR OTHERWISE) SHALL BE EFFECTIVE UNLESS SPECIFICALLY SET FORTH IN A WRITTEN INSTRUMENT SIGNED BY AN OFFICER OF SOMAT®.

Table of Contents:

SPC-75S, SPC-75UDT

Introduction.....

Safety Instructions

General Description & Definitions

Installation.....

Unpacking

Mechanical Installation

Plumbing Installation

Electrical Installation

Start-up.....

Forms & Lists

Warranty Validation

Operation.....

Cleaning & Maintenance.....

Cleaning

Maintenance

Troubleshooting

Replacement Parts.....

Pulper

Extractor

Electrical Panel

Safety Precautions and Warnings



READ THE MANUAL COMPLETELY BEFORE ATTEMPTING TO OPERATE THE UNIT.

HIGH VOLTAGE! DO NOT PERFORM ANY REPAIRS TO MOTORS OR CONTROL SYSTEMS WITHOUT TURNING OFF THE MAIN POWER.

ALWAYS ***TURN THE MAIN POWER OFF*** AND LET ALL MOTORS COME TO A STANDSTILL BEFORE DOING ANY MAINTENANCE ADJUSTMENTS OR CLEANING OF THE UNIT.

BEFORE STARTING, BE SURE ***ALL PERSONNEL ARE CLEAR*** OF MOVING PARTS.

KNOW LOCATION AND FUNCTIONS OF ALL ***START/STOP BUTTONS*** AND SAFETY SWITCHES.

DURING PERIODIC MAINTENANCE, ***CHECK ALL SAFETY SWITCHES*** TO BE SURE THEY ARE OPERATING PROPERLY.

DO NOT REMOVE OR ALTER GUARDS.

DO NOT REMOVE SAFETY LABELS. IF LABELS ARE MISSING OR DESTROYED, CONTACT FACTORY FOR REPLACEMENT.

DO NOT OBSTRUCT ELECTRICAL PANELS OR PUSH BUTTONS.

GOOD HOUSEKEEPING IS THE MOST IMPORTANT SAFETY PROCEDURE.

Safety Precautions and Warnings

This equipment has locations which are hazardous and cause severe injury or death if warnings are not followed. Always turn off power before reaching into any unit!

Maintenance to be performed by trained and authorized personnel.



This equipment has moving parts operating at high speeds! Death or serious injury can occur if warnings are not followed.



This equipment has moveable lids protecting you from moving parts. Do not alter safety devices or guards. Do not reach into any part of the unit with the power turned on.



This equipment uses High Voltage! Only trained and authorized personnel should perform maintenance on the electrical components of this machine.



This equipment has moving parts that can crush and cut. Do not alter safety devices or guards. Do not reach into any part of the unit with the power turned on.

Caution: Damage will occur to this equipment if unsafe objects are fed into the machine(s). Keep these items out of the machine(s) to avoid component failure and unwanted downtime. When in doubt, keep it out of the machine(s)!



Always turn the power off before servicing the pulper!

GENERAL DESCRIPTION

The SOMAT® system prepares solid waste materials for disposal by transforming the materials, with water, into a pulp. This transformation takes place in a unit called a Pulper which is designed to pulp all forms of paper, plastic, foil, and food waste. The waste material is fed manually or automatically to the Pulper. The continual down flow of water and the rotation of the Pulper impeller create a strong vortex action which pulls the waste down against the cutting blades of the impeller. The resultant slurry is then forced through a perforated stainless steel Sizing Ring surrounding the impeller.

Items such as tin cans, silverware, nails, bolts and other non-palpable objects which may be inadvertently fed into the Pulper are separated out of centrifugal force and gravity and are caught in the junk box within the Pulper. This junk box should be emptied manually during cleanup.

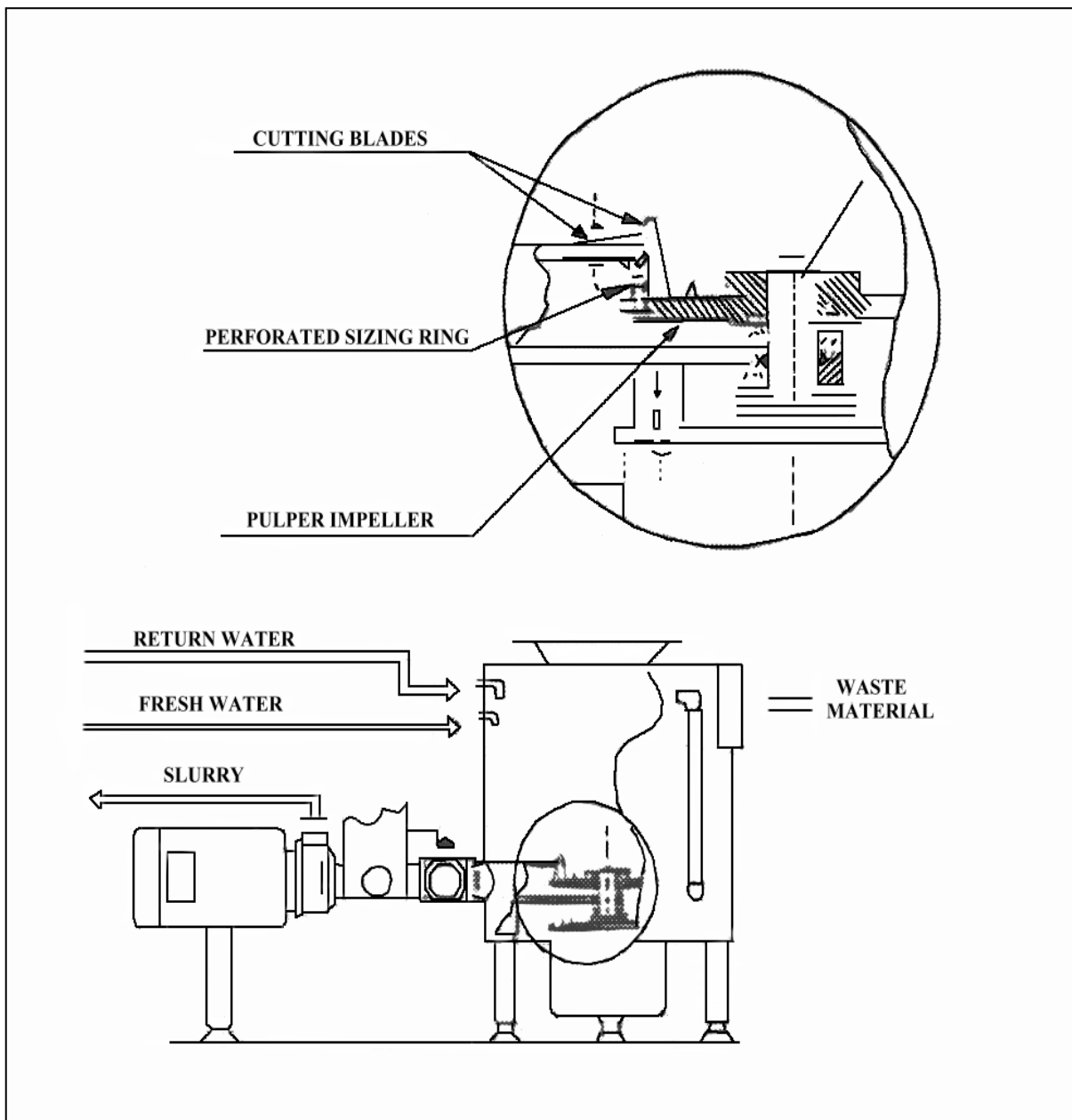

TYPICAL PULPER

The SOMAT® System is designed to pump the mixture of macerated solids and water, called slurry, to the Hydra-Extractor® where the slurry is reduced to a semi-dry pump. Within the Hydra-Extractor®, the slurry is carried by a helicoid screw within a perforated tubular screen. The water passes through the screen and is pumped back to the pulping unit. The solids continue up the helicoid screw to a compression chamber or plug area where additional water is removed by extrusion. The solids in this area are called the plug. This plug is broken up at the Hydra-Extractor® discharge opening by a cutter and the pulp then falls out of the discharge chute.

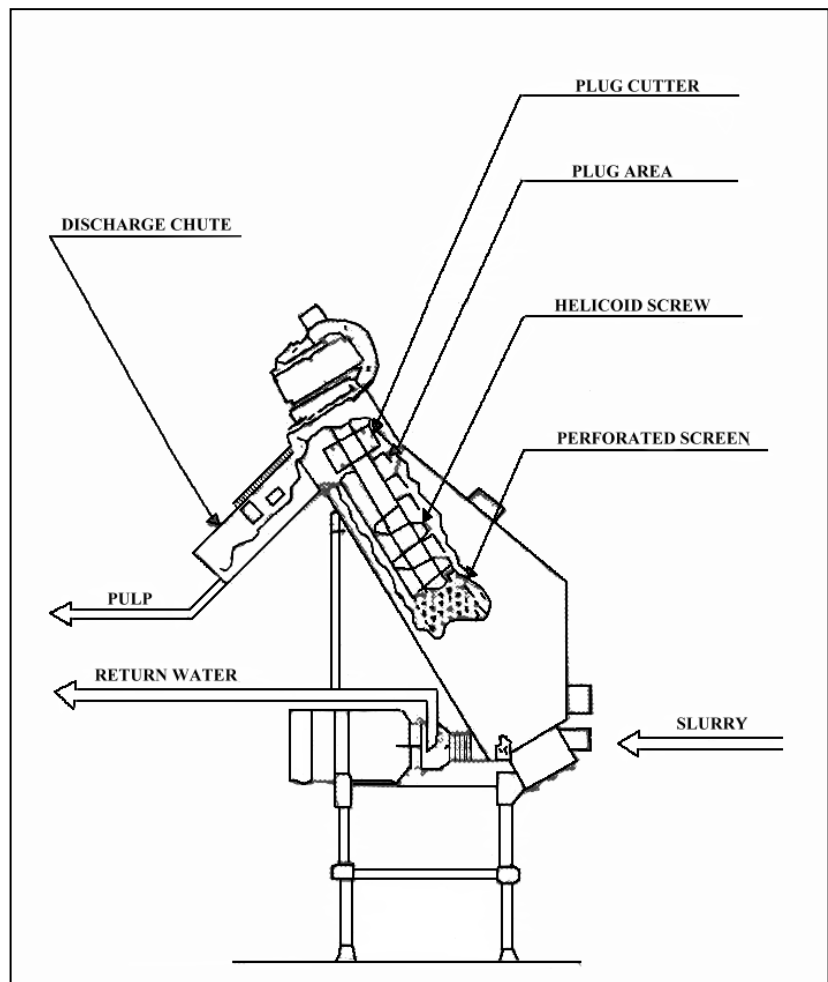

TYPICAL HYDRA-EXTRACTOR®

This system is capable of reducing the volume of average non-compacted waste by approximately 80 percent.

The system is powered by electric motors with the associated controls housed in Som-A-Trols (electric control panels). Since, in the course of operation, some water is absorbed by the pulp, fresh make-up water is supplied to the Pulper automatically through a solenoid valve which responds to a water level sensor.

In addition to the basic system as discussed to this point, numerous additional items of equipment may or may not be required to comprise a specific system.

DEFINITIONS – GENERAL

1. Pulper - SOMAT® device that contains an impeller and security ring to grind solid waste. The resultant mixture of waste particles and water is called slurry.
2. Hydra-Extractor® - Inclined screw-type press for removing transport water from pulp.
3. Slurry - A water solution containing a low percentage of suspended solids.
4. Pulp - Semi-dry solid from which transport water has been extracted.
5. Som-A-Trol® - Electrical control panel, including motor starters and sequencing controls for automatic operation of the SOMAT® system.
6. Slurry Pump - Specially designed pump used to transport slurry from a SOMAT® Pulper to Hydra-Extractor®.
7. Return Pump - Specially designed pump used to return water from Hydra-Extractor® to SOMAT® Pulpers.
8. Water Level Control - a PLC controlled function utilizing time based programming.
9. Chemical Additive Pump - A proportioning type Additive pump that adds de-foaming, deodorizer, and/or buffering solutions to the process water.
- * 10. Pulp Screw Conveyor - Transport screw used for conveying pulp to a point remote from Hydra-Extractor®.
- * 11. Distributing Type Pulp Screw Conveyor - Transport screw with discharge ports throughout its length for even distribution in large haul-away containers.
- * 12. Water economizing tank- Reservoir for return water used in large systems.
 - * Optional equipment which may not be furnished with your Pulping System.

DEFINITIONS – COMPONENTS

SOMAT® PULPER:

1. Tank - Pulping or grinding chamber of the SOMAT® Pulper.
2. Impeller - Rotating metal plate with Cutting Blades and Tungsten Carbide teeth which de-fiber and pulp the waste and along with the Security Ring provides a shearing action for non-fibrous waste.
3. Security Ring - Perforated stainless steel ring surrounding the impeller through which all slurry must pass after waste is pulped. Dimensions of security ring holes controls particle size of materials leaving the Pulper.
4. Junk Box - Chamber in bottom of tank that segregates non-pulpable materials from tank.

HYDRA-EXTRACTOR®:

1. Screw - Vertical helix which lifts and compresses solids from the slurry and permits water to drain off by gravity.
2. Screen - Mesh screen that surrounds the screw, through which water drains off.
3. Plug - Mass of pulp extending beyond last helix of the screw. The force required to extrude the plug squeezes additional water from pulp.
4. Brush - Nylon brush attached to edge of screw helix which serves to clean the screen.
5. Plug Cutter – Assists in breaking apart waste to discharge down the chute

GENERAL:

1. Throttling Valve - Full ported gate valve used to control water flow.
2. Timer - Electrical device used to automatically shut down the SOMAT® System at a pre-determined time.
3. Fresh Water Solenoid - Electric valve used to control fresh water make-up to the SOMAT® System.
4. Motor Operated Valve - (MOV) Electric valve used to control return water flow in the system.
5. PLC- Computer controller designed to handle pulper and extractor operation.

Installation

UNPACKING

The crate containing your SOMAT® Pulper will contain the following items:

Pulper

Tray, if so equipped

Som-A-Trol® Panel

Misc. parts box containing:

ALL UNITS:

Anti-Vibration



Pads

Installation Drawings

UDT UNITS ONLY:

Stainless Steel Lid

Stainless Steel Cone Adapter (Unless shipped directly to table manufacturer).

UDT Gasket

TRAY ONLY:

Gasket & Hardware

Return Water Assembly

TROUGH ONLY:

Trough Gasket & Hardware

Trough Nozzles & Throttling Gate Valves

(See Installation Drawing for quantity)

OPTIONAL EQUIPMENT:

Remote Push Button Station

Trough Magnet & Hardware

Feed hood

MECHANICAL INSTALLATION

HIGH TANK MODELS:

- 1) Put the pulper/extractor into position as shown on the Installation Drawings.
- 2) Place the Anti-Vibration Pads under each leg of the Pulper and Hydra-Extractor®.
- 3) TRAY FEED UNITS ONLY - Install the tray to the Pulper (if it was not already installed at the factory) using the provided gasket material and hardware.
- 4) TROUGH FEED UNITS ONLY - Install the provided trough gasket between the Pulpers inlet and the trough outlet and secure with the provided hardware.

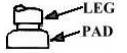

UDT MODELS:

- 1) Cut a hole in the top of the table as shown in the Installation Drawing using the following diameter: SPC-75S Pulper - 22" Diameter hole
- 2) Center the provided UDT Cone beneath the opening and weld it into place as shown. Please follow print detail for welding instructions.
- 3) Put the Pulper into position.
- 4) Place the anti-vibration pads under each leg of the Pulper and Hydra-Extractor®.
- 5) Install the UDT gasket onto the Pulper tank and around the outside of the adapter cone.
*see image on next page
- 6) Adjust the Pulper and Hydra-Extractor® legs so that the rubber UDT gasket provides a water tight seal with 2" clearance between Pulper and table.
- 7) Install the provided trough gasket between the Pulpers inlet and the trough outlet and secure with the provided hardware.

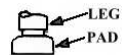

REV	DESCRIPTION	DATE	APPROVED

INSTALLATION OF UDT GASKET/FIT TO UDT ADAPTER RING

THE UDT GASKET IS HELD TO THE UNDERSIDE OF THE PULPER TOP BY THE FOUR SEAL CLAMPS AND BOLTS. ELEVATE THE PULPER UNTIL THE GASKET IS IN CONTACT WITH THE BOTTOM EDGE OF THE UDT ADAPTER RING. FROM THE INSIDE OF THE PULPER, CUT A HOLE IN THE GASKET USING THE ADAPTER RING AS A GUIDE (ROUGHLY 18 3/4 ϕ). ELEVATE THE PULPER THE REMAINDER OF THE WAY SINKING THE ADAPTER RING INTO THE HOLE IN THE GASKET.

*****IMPORTANT*** THE CIRCLE CUT MUST BE SMOOTH, JAGGED EDGES WILL ADVERSELY AFFECT THE SEALING CAPABILITY OF THE GASKET.**

<small>UNLESS OTHERWISE SPECIFIED DIMENSIONS ARE IN INCHES</small> TOLERANCES MACHINING: 18" ± 1/32" 16" ± .01" 10" ± .005" ANGLES: ± 1/2°	NOTICE <small>This is a reproduction of a user's copy. Reproduction without express permission is prohibited. All rights reserved. © SOMAT COMPANY, INC. 2014. Printed in the USA. 3-17-14</small> DRAWN BY: R/LH CHECKED BY: DATE: 06/24/14 ASSEMBLY:	 <small>SOMAT COMPANY WASTE-WELDING SYSTEMS 955 FOX CHASE, SUITE 107 COATSDALE, PA 19320</small> LID, GASKET & RING INSTALL SP-75S, SPC-75S
<small>UNLESS OTHERWISE SPECIFIED MACHINED SURFACE FINISH IS 32 RMS BRASS SHARP EDGES (SEE 615) FILLETS (SEE 625) AND CHAMFERED CORNERS MUST BE AT LEAST TREATING AND PLATING</small>	SIZE: B SCALE: 1/4"	FSCM NO: DWG NO: B100773 REV: — WEIGHT: SHEET: 1 OF 1

MOUNTING OF THE GRABBER MAGNETS:

Preferred: Locate per detail below and weld into place.

Optional: Drill four 7/32" diameter holes into the trough as shown below. Seal the heads of the provided screws with silicone and attach the magnet.

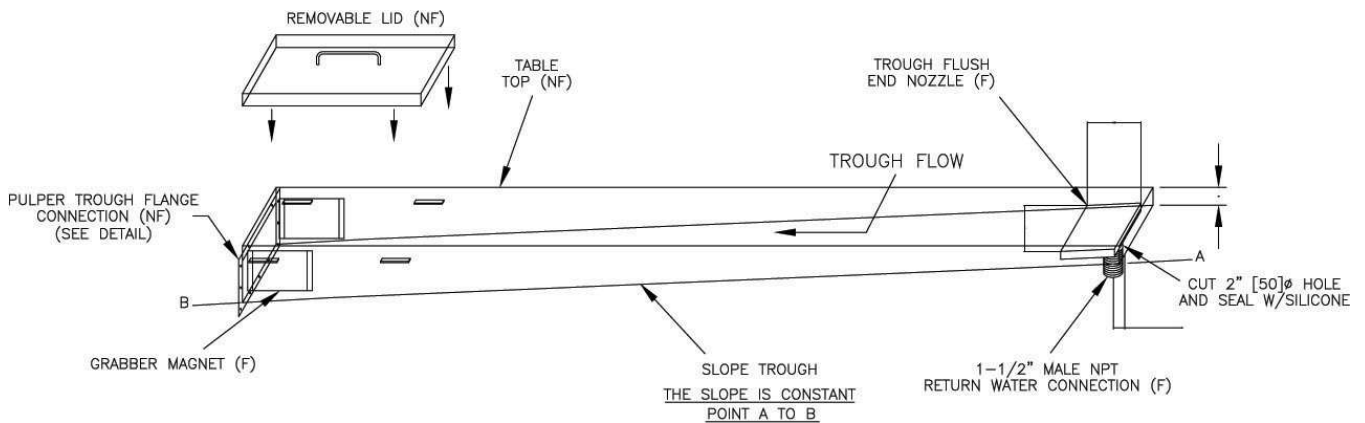

RECOMMENDED POSITION OF THE GRABBER MAGNETS

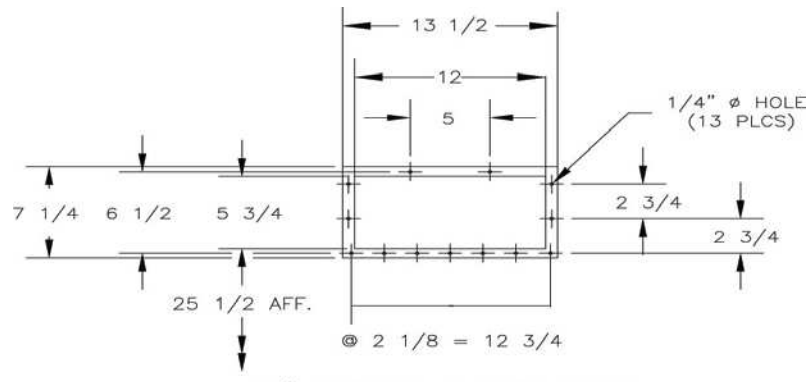

12" TROUGH FLANGE DETAIL

MOUNTING DETAIL OF TROUGH

PIPING INSTALLATION

- 1) PIPING FOR FRESH WATER LINES AND DRAIN LINES NOT SUPPLIED BY SOMAT®.
- 2) PIPE SIZES TO BE IN ACCORDANCE WITH SOMAT® RECOMMENDATIONS.
- 3) ALL FITTINGS MUST BE PRESSURE RATED DRAINAGE TYPE.
- 4) KEEP DRAINS ACCESSIBLE TO UNIT. DO NOT INSTALL DRAINS UNDER SOMAT® EQUIPMENT.
- 5) NO EXTERNAL STRAIN TO BE EXERTED ON SOMAT® EQUIPMENT.
- 6) PROTECT ALL SOMAT® EQUIPMENT AND PIPING FROM FREEZING AND CONDENSATION.
- 7) ALL PIPING TO BE IN ACCORDANCE WITH STATE AND LOCAL PLUMBING CODES.
- 8) "F" = FURNISHED BY SOMAT / "NF" = NOT FURNISHED BY SOMAT

FRESH WATER:

NOTE: In Massachusetts, the Public Water Supplier shall be contacted regarding the proper backflow prevention device to be installed.

- 1) Bring a 1/2" cold water line for the SPC-75S, to the pre-piped fresh water assembly. (See enclosed diagram and Installation Drawings)
- 2) Bring a 1/2" hot water line to the pre-piped fresh water assembly on the Hydra-Extractor (see enclosed diagram and Installation Drawing).

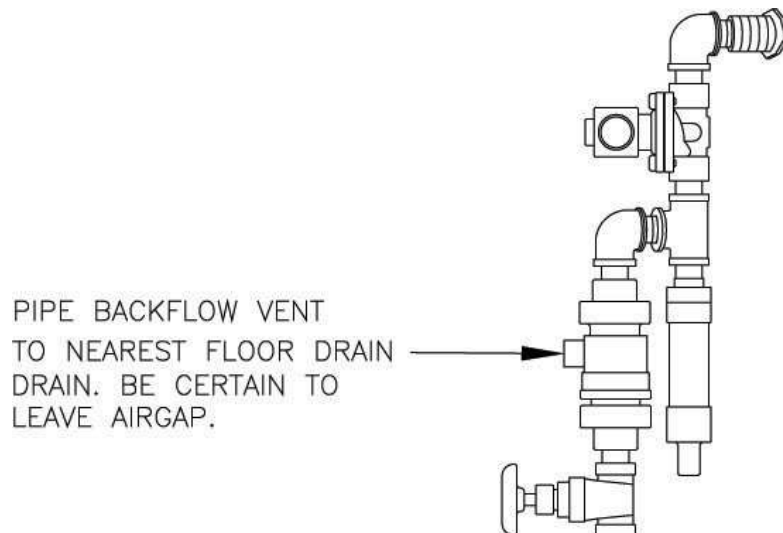

HYDRA-EXTRACTOR® OVERFLOW AND PULPER DRAIN:

- 1) Install 1-1/2" pipe from the Hydra-Extractor® overflow to floor drain (**DO NOT REDUCE**).
- 2) Install 2" pipe from the Pulper drain to floor drain (**DO NOT REDUCE**).

RETURN PIPING FOR UNITS WITH A TRAY FEED ONLY:

- 1) Install the pre-piped return water assembly onto the return pump (if not already factory installed) (see enclosed diagram and Installation Drawings).
- 2) Install one side of the provided tubing over the return water elbow on the feed tray and the other side onto the pump return water assembly (if not already factory installed).
- 3) Install the provided hose clamps at each connection.

RETURN PIPING FOR UNITS WITH A TROUGH:

- 1) Pipe from the return pump to the supplied trough end flush nozzle and silver saver connections as well as to the optional trough nozzles as shown in the trough detail on the Installation Drawing using the provided throttling gate valves

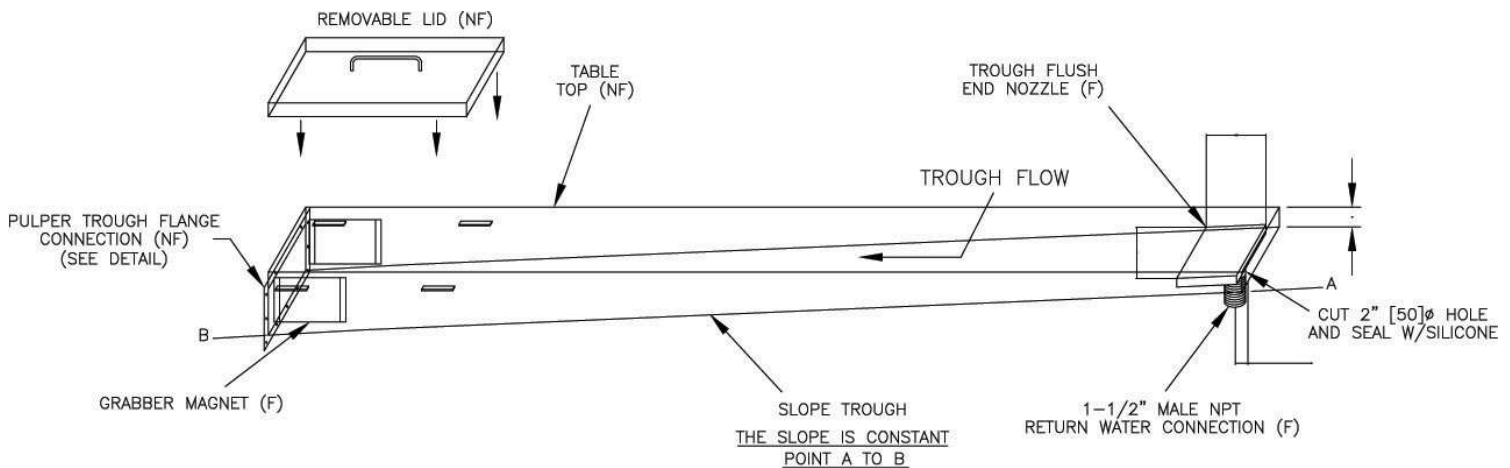

NOTE: All Pre-Piped Assemblies are hand tightened for shipping purposes only.

ELECTRICAL INSTALLATION

- 1) *PRE-WIRED CONTROL PANELS, OPERATOR DEVICES & ELECTRIC VALVES BY SOMAT.*
- 2) *INSTALL CONDUITS FROM PANEL TO PREWIRED JUNCTION BOX, PULL MOTOR WIRES AND CONTROL WIRES THRU SEPERATE CONDUIT AND DO THE FINAL TERMINATIONS.*
- 2) *GROUND ALL ELECTRICAL EQUIPMENT.*
- 3) *CONTROL CIRCUIT TO BE 115 VAC AND/OR 24VDC NOMINAL. (SEE APPROVED DRAWINGS)*
- 4) *ALL SOM-A-TROL PANELS ARE TO BE WIRED IN ACCORDANCE TO LOCAL, STATE AND/OR NATIONAL ELECTRIC CODE (NEC 1993) SPECIFICATIONS.*
- 5) *INTEGRAL PUSH BUTTONS ARE LOCATED IN PANEL DOOR AND PRE-WIRED AT FACTORY. OPTIONAL REMOTE PUSH BUTTON STATION IF SUPPLIED; TO BE MOUNTED & WIRED AT WORK STATION BY ELECTRICIAN. (BRACKET REQUIRED BY CUSTOMER).*

PANEL & OPTIONAL REMOTE PBS MOUNTING:

- 1) Mount the Som-A-Trol® in a suitable location (see Installation Drawings) so that the bottom of the panel is at least 42" above the finished floor or in accordance with ADA requirements.
- 2) Install the Optional Remote Push Button Station onto the Dish Table or at another convenient location. (See Diagram and Installation Drawings.)

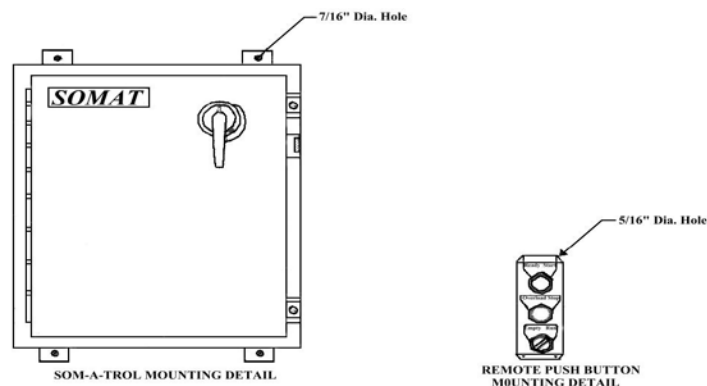

MOUNTING PATTERN FOR THREE HOLE PUSH BUTTON STATIONS

SUPPLYING THE SOM-A-TROL® WITH POWER

Bring the (4 wire) customer power supply to the top right side of the Som-A-Trol® and connect to the panel disconnect and ground lug. (See Diagram and Installation Drawings.)

All close couple systems are prewired; there is a prewired junction box mounted to the side of the extractor shell. Inside this prewired junction box there will be terminals that are the same as in the panel. Install conduits from the panel to the pre-wire junction box, pull the motor wires and control wires thru these conduits separately and do your final wire terminations matching numbers from panel to pre-wire junction box.

REMOTE PUSH BUTTON STATION

Mount the remote push button station, run the conduit from the remote push button station to the prewired junction box then pull the wires from the remote push button station to the prewired junction box and do your final hookups in the prewired junction box.

WARNING:

Improper connection of the equipment grounding conductor can result in a risk of electrical shock. An equipment grounding conductor must be run with the circuit conductors and connected to the pulper/extractor grounding terminal.

**CUSTOMER POWER SUPPLY
(BY ELECTRICAL CONTRACTOR)**

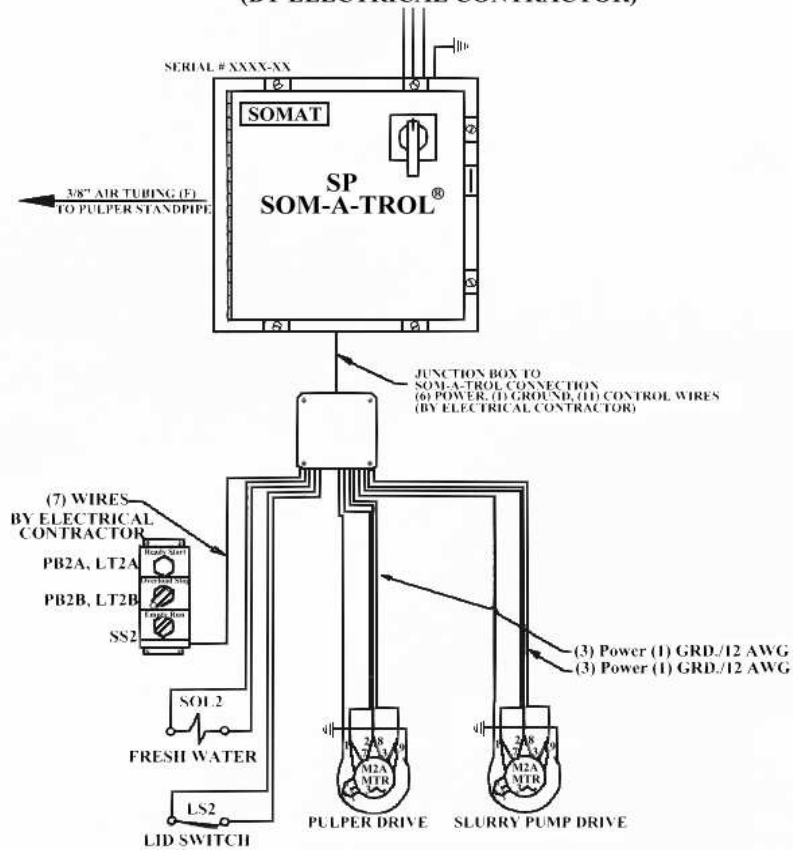

208/230 VAC

WIRE SIZING GUIDE		
DEVICE	WIRE SIZE	TYPE
SOM-A-TROL CONTROL LOGIC (LIMIT SWITCH) (SOL. VALVE ETC.)	18 AWG	THW-75C
3HP SLURRY PUMP 3HP RETURN PUMP MOTOR 208/230V	14 AWG	THW-75C
5HP SLURRY PUMP 5HP RETURN PUMP MOTOR 208/230V	12 AWG	THW-75C
3HP PULPER DRIVE 3HP EXTRTR DRIVE MOTOR 208/230V	14 AWG	THW-75C
5HP PULPER DRIVE 5HP EXTRTR DRIVE MOTOR 208/230V	12 AWG	THW-75C
7.5 PULPER DRIVE 7.5 PUMP DRIVE MOTOR 208/230V	10 AWG	THW-75C

USE NEXT SIZE AWG FOR RUNS OVER 150 FEET (48 METERS)

460 VAC

WIRE SIZING GUIDE		
DEVICE	WIRE SIZE	TYPE
SOM-A-TROL CONTROL LOGIC (LIMIT SWITCH) (SOL. VALVE ETC.)	18 AWG	THW-75C
3HP SLURRY PUMP 3HP RETURN PUMP MOTOR 460V	14 AWG	THW-75C
5HP SLURRY PUMP 5HP RETURN PUMP MOTOR 460V	14 AWG	THW-75C
3HP PULPER DRIVE 3HP EXTRTR DRIVE MOTOR 460V	14 AWG	THW-75C
5HP PULPER DRIVE 5HP EXTRTR DRIVE MOTOR 460V	14 AWG	THW-75C
7.5 PULPER DRIVE 7.5 PUMP DRIVE MOTOR 460V	14 AWG	THW-75C

USE NEXT SIZE AWG FOR RUNS OVER 150 FEET (48 METERS)

FOR REFERENCE ONLY

Start Up

After installation is complete, your equipment will be started up by a qualified Somat service representative. This start up will get your unit running in accordance with Somat guidelines. The equipment may be demonstrated to you by the service company or the equipment rep themselves.

The Somat equipment carries a 1 year warranty from date of start up. To accurately track this information, we ask that you fill out the Warranty Registration Sheet below and fax back to us. This will ensure your equipment is registered with Somat's Service Department and will allow Somat's Service Department to efficiently process a warranty claim if one should arise.

You will also find copies of instructions for the equipment operators if the originally packaged laminated sheets are lost or damaged.



WARRANTY REGISTRATION FORM

Serial # :	Model # :	SPC-75
------------	-----------	--------

Date of Start Up: ____/____/____

Customer Name: _____

Address: _____

City: _____ State: _____ Zip: _____

Contact Name: _____

Contact Number: _____ Fax: _____

Service Company: _____

City: _____ State: _____ Zip: _____

Please fax to:

Somat Company Service Department



717-291-0878

OR send with startup paperwork.

WARRANTY REGISTRATION FORM



SP-75 PULPER START/STOP INSTRUCTIONS

TO PRE-FILL AND START PULPER:

- ✓ TURN POWER ON AT MAIN CONTROL PANEL
- ✓ RELEASE LOCK LEVER ON STOP BUTTON 
- ✓ PRESS GREEN BUTTON AND UNIT WILL PRE-FILL 
- ✓ ONCE GREEN LIGHT IS LIT SOLID, UNIT IS READY TO RUN 
- ✓ IF UNIT DOES NOT PRE-FILL
 - RELEASE STOP BUTTON
 - PULL OUT ON EMERGENCY STOP
 - ENSURE POWER IS ON

- ✓ PRESS GREEN START BUTTON TO OPERATE MACHINE 

TO STOP AND SHUTDOWN PULPER:

- ✓ TO STOP PULPER, PRESS RED STOP BUTTON ONCE 
- ✓ AT END OF DAY PRESS BLACK 'TIMED STOP' PUSHBUTTON ONCE 
- ✓ WAIT UNTIL UNIT SHUTS DOWN BY ITSELF
- ✓ PRESS 'DRAIN' PUSHBUTTON ON MAIN PANEL DOOR 
- ✓ LOCK IN STOP BUTTON WITH LOCKING LEVER
- ✓ CLEAN UNIT

TO START UNIT AFTER TIMED STOP:

- ✓ PRESS GREEN PUSHBUTTON ONCE AND FOLLOW INSTRUCTIONS FROM THE TOP 

Operation

OPERATING INSTRUCTIONS

TYPICAL STARTUP AND OPERATING PROCEDURE - The following startup procedures must be followed prior to operating the System:

1. Check to ensure that the main power switch of the SOM-A-TROL® panels is in the "ON" position.
2. Unlock the Pulper **STOP** button. Push **GREEN** pushbutton on SOM-A-TROL panel or remote pushbutton station to close drain if opened. If drain is open, you will see a slow **GREEN** flash to indicate the drain is open. Once pressed, the drain will automatically close and pre-fill the pulper tank.
3. The Pulper will begin to fill with water, this is indicated by a steady flashing **GREEN** light. When the water has reached the prescribed level as indicated by a solid **GREEN** light, press the Pulper **START** button and wait until there is a continuous flow of return water before feeding waste to the Pulper either manually or by starting waste down the flushed trough, if so equipped.

Waste Feeding Instructions - Best results are obtained if the Pulper is fed waste at a **UNIFORM RATE**. *Under normal conditions, waste may be fed to the Pulper as long as a strong vortex is maintained in the tank. If waste is fed too fast the vortex will diminish to a point where it will no longer pull the material into the impeller for efficient grinding.*

Do not "starve" the Pulper. If no waste is available for disposal, Press the STOP button. Don't "slug" the Pulper for short periods of time with excessive feeding. Overloading interferes with the grinding process and takes longer to dispose of a given quantity of waste than if the machine is fed at a UNIFORM RATE.

When shutting down the Pulper for short periods, it is not necessary to run the Pulper until all the waste has been pumped out of the tank. Run the Pulper for a few minutes to thin down the slurry and then shut off the machine.

SHUTDOWN PROCEDURES - The following shutdown procedures must be followed prior to performing necessary cleaning and maintenance duties.



1. Allow the Pulper to operate approximately fifteen minutes after the last waste has been fed.
2. Depress black "**TIMED STOP**" pushbutton once to engage spray rinse system, system will then time out on its own. The Pulper will stop when the shutdown timer has timed out.
3. Press "**DRAIN EMPTY**" pushbutton on panel door to drain system. This pushbutton will **DRAIN ONLY**, you must press **GREEN** start button to close drain. This will pre-fill the system again.
4. Lock in the **STOP** button lock and turn power off to perform any cleaning or maintenance.
5. Refer to the applicable Pulper and Hydra-Extractor® maintenance sections of this manual for daily, weekly and long term shutdown cleaning procedures and maintenance instructions.

To ensure all food waste is removed from the extractor, you can use Styrofoam plates as a cleaning agent for the unit. The Styrofoam will force out the majority of food waste leaving only Styrofoam. Run the plates as you would any waste, and continue until nothing but Styrofoam exits the extractor. We do not recommend using cardboard as it will dry out and create a very hard obstruction in the extractor which could cause motor overload on restart.

Print sequence of operation on next page for display for operators.



SP-75 PULPER START/STOP INSTRUCTIONS

TO PRE-FILL AND START PULPER:

- ✓ TURN POWER ON AT MAIN CONTROL PANEL
- ✓ RELEASE LOCK LEVER ON STOP BUTTON 
- ✓ PRESS GREEN BUTTON AND UNIT WILL PRE-FILL 
- ✓ ONCE GREEN LIGHT IS LIT SOLID, UNIT IS READY TO RUN 
- ✓ IF UNIT DOES NOT PRE-FILL
 - RELEASE STOP BUTTON
 - PULL OUT ON EMERGENCY STOP
 - ENSURE POWER IS ON

- ✓ PRESS GREEN START BUTTON TO OPERATE MACHINE 

TO STOP AND SHUTDOWN PULPER:

- ✓ TO STOP PULPER, PRESS RED STOP BUTTON ONCE 
- ✓ AT END OF DAY PRESS BLACK 'TIMED STOP' PUSHBUTTON ONCE 
- ✓ WAIT UNTIL UNIT SHUTS DOWN BY ITSELF
- ✓ PRESS 'DRAIN' PUSHBUTTON ON MAIN PANEL DOOR 
- ✓ LOCK IN STOP BUTTON WITH LOCKING LEVER
- ✓ CLEAN UNIT

TO START UNIT AFTER TIMED STOP:

- ✓ PRESS GREEN PUSHBUTTON ONCE AND FOLLOW INSTRUCTIONS FROM THE TOP 

Light Codes:

Newer SOMAT systems employ a micro-computer to control many of the unit functions. If a fault or overload is detected, the system will flash a series of codes by lights located either on the pushbutton station OR on the panel enclosure itself. Below is a list of the most commonly used for close coupled machines.



Solid **Green**: All safeties are latched and secure, system is ready to run

Flashing **Green**: System is in timed stop mode, extractor will spray, after less than 10 minutes system will shut down.

Slow flashing **Green**: Unit drain is open, press **Green** pushbutton to close drain.

Two **Green** flash, pause, and repeat: All safeties are latched and secure, tank is filling.

Solid **Red**: One of systems 3 motors is overloaded and must be reset

Flashing **Red**: Lid switch on pulper or extractor lid is open, shut lid to resume normal operation

SPECIAL OPERATING CONDITIONS - While applications vary widely the following conditions could occur and should be watched for:

- A. Overfeeding - The SOMAT® Pulper is designed as a continuous process machine. In general, the feed rate should not exceed one tenth of the rated hourly capacity in any six minute period. Exceeding this will cause the machine to bog down and operate under its rated capacity.
- B. Foaming - this is caused by contaminants in the water, or by certain materials in the waste, such as glue in corrugated cardboard and excessive starches. Add a de-foamer, such as Somat® defoamer, or any of a number of commercial preparations.
- C. Corrosion - If the water and/or the waste are acidic or alkaline, use a buffering agent to neutralize the water. Regular testing is recommended, since rapid corrosion due to acidic or alkaline conditions can result in costly repairs.
- D. Freezing - All equipment and piping should be protected from freezing. Insulation and heating cable are often used where equipment is exposed.
- E. Non-Pulpables - The SOMAT® Pulper is designed to handle a limited amount of non-pulpable material. The lighter items are eventually ground and the heavier material is discharged into the junk box. However, the SOMAT® Pulper is not designed to handle heavy masonry materials or tramp iron and other materials of this nature. Such items will break away the cutting teeth and seriously reduce the machine's ability to handle material of any kind.

OPERATING INSTRUCTIONS

Occasionally, the amounts of non-pulpables may become excessive and, due to their slower processing rate, create a material build-up in the Pulper tank. Safely stop the Pulper, scoop out the non-pulpable matter, and then re-start the Pulper.

- F. Wear - Moving parts, and their mating surfaces, will wear with service, especially those which are part of cutting mechanisms. Your routine maintenance and inspection, as described in the applicable component sections, will disclose which parts are wearing and provide an indication as to when replacement will be necessary. The maintenance plan should include pre-ordering of spare parts and scheduled replacement. Rotating blades may be re-sharpened. To remove blades please follow instructions located in the "Cutting Mechanism" section of this manual.

CLEANING YOUR SYSTEM

CLEANING INSTRUCTIONS

After feeding waste to the SOMAT[®] System has been completed for the day, the equipment should be thoroughly cleaned. The cleaning operation requires only a few minutes daily and, if properly done, will keep the machine free of odor and at top-operating efficiency. A regular cleaning program will eliminate costly maintenance and unsatisfactory operation.

CLEANING THE PULPER:

With the system properly shut down, in accordance with the System "Shutdown Procedures", perform the following:



1. Clean the Junk Box of non-pulpable material

CAUTION!
THERE MAY BE BROKEN GLASS PRESENT
IN THE PULPER!

2. Wash the interior of the Pulper shell with a hose, suitable brush, detergent and deodorant or other cleaning solution. Exercise particular care in cleaning the underside of the upper shell flange.
3. Wipe down the equipment exterior.
4. Leave lid open (if allowed) to let machine air out and reduce odors. Close lid and follow start procedure to refill unit.

To ensure all food waste is removed from the extractor, you can use Styrofoam plates as a cleaning agent for the unit. The Styrofoam will force out the majority of food waste leaving only Styrofoam. Run the plates as you would any waste, and continue until nothing but Styrofoam exits the extractor. We do not recommend using cardboard as it will dry out and create a very hard obstruction in the extractor which could cause motor overload on restart.

CLEANING THE HYDRA-EXTRACTOR®:

1. With high pressure hose, wash down screens and interior walls of Hydra-Extractor® housing. If necessary, a long-handled brush can be used.

B. Long Term Shut Down Procedure - If the Pulper is to remain idle for a relatively long period (four weeks or more), special procedures should be taken to protect the equipment. These procedures are as follows:

1. Perform the daily cleaning procedure, and then circulate a solution of a cleaning and disinfecting agent through the lines to combat bacteria growth and odor.
2. Remove the impeller from the Pulper, (refer to Pulper Maintenance Section). Do not remove the mechanical seal. Using a hose and brush, thoroughly clean the mechanical seal, slurry chamber, and the underside of the impeller.

To ensure all food waste is removed from the extractor, you can use Styrofoam plates as a cleaning agent for the unit. The Styrofoam will force out the majority of food waste leaving only Styrofoam. Run the plates as you would any waste, and continue until nothing but Styrofoam exits the extractor. We do not recommend using cardboard as it will dry out and create a very hard obstruction in the extractor which could cause motor overload on restart.

CLEANING COMPOUNDS

The ideal cleaning compounds available for use with SOMAT® equipment combine four important functions: detergency, disinfection, pH buffering and odor counter action.

In order to help our customers overcome the problem of selecting chemicals for use with their SOMAT® System, we offer the chemicals that we believe will best meet their needs.

We offer:

SOMAT® NEUTRO PLUS (72000)

Designed for use in the SOMAT® System to keep it clean, to deodorize, and to reduce grease build-up. This is an industrial strength product. The surfactants in this detergent/deodorant are bio-degradable.



SOMAT® DEFOAMER (73000)

A neutral, liquid silicone emulsion specifically designed for suppressing and controlling undesirable foam. This is an industrial strength product. The surfactants in this de-foamer are bio-degradable.

Dilution: Five (5) parts water to one (1) part de-foamer.

Please direct all orders, whether by mail, phone, or by email to our PARTS DEPARTMENT. If you have any questions, please feel free to contact us at this office.

CAUTION – CORROSION

In isolated cases, depending on local water supply characteristics and operating conditions, the mild steel components in the SOMAT® System can be subject to corrosion.

This condition is generally associated with food service machines. Corrosion may occur in steel piping, pulping tanks, fittings, and pump parts. Corrosion works very rapidly and the pitting of metal parts can cause early failure, requiring extensive repairs.

Acid corrosion is caused by low pH level in the system water, but it can be easily controlled by the addition of commercial grade soda ash. Soda ash is readily available and costs only a few cents a pound in bulk lots.

Alkaline Corrosion is caused by high pH level in the system water. While damages done by this condition does not occur as quickly as that of Acid corrosion, neutralizing agents should be added to the system to help eliminate potential corrosion problems. The proper pH level of the system water should be maintained at a minimum of 7.0 and not over 8.5. The pH level can be determined by a simple test using litmus paper indicators.

GENERAL TEST AND TREATMENT PROCEDURE

1. After the system is in operation under normal load conditions, dip litmus test paper in grinder slurry (or return water from Hydra-Extractor[®] and determine whether the liquid is acid or alkaline.
2. Neutral water is neither acidic nor alkaline and will have a pH of 7.0. An acid liquid will have a pH of less than 7.0, as is indicated by the color change of the litmus paper.
3. If the liquid is neutral (a pH of 7.0) no treatment is required.

NOTE: SOMAT Company cannot be responsible for failure due to corrosion resulting from improper water conditions.

MAINTENANCE

PERIODIC MAINTENANCE AND INSPECTION

These procedures consist primarily of regularly scheduled cleaning and inspections. The time intervals cited are based on normal use of the SOMAT® unit; approximately **six hours per day**, seven days per week. Equipment operating more than this or in severe service will require more frequent inspection/maintenance.

Particular attention should be paid to cutting blades and grinding teeth as these will sustain the highest degree of wear. Continued adherence to these inspections will provide adequate lead time when ordering spare parts, thereby minimizing unnecessary and costly equipment downtime.

PREVENTIVE MAINTENANCE INSPECTION SCHEDULE

PULPER	DAILY	WEEKLY	MONTHLY	QUARTERLY
1. GENERAL				
a. Check shell and slurry chamber for wear.			X	
b. Check exterior finish for corrosion.			X	
2. IMPELLERS				
a. Check impeller blades for wear.		X		
b. Check stationary blades for wear.		X		
c. Check impeller for wear.		X		
d. Check security ring for wear.		X		
3. DRIVE				
a. Check seal for leakage.	X			
b. Check bearings for noise and wear.				X

	DAILY	WEEKLY	MONTHLY	QUARTERLY
1. GENERAL (Overhaul yearly)				
a. Check cutting mechanism for non-pulpable object impact damage.	X			
b. Check bolts for tightness.		X		
c. Check stationary cutter block to impeller cutter ear clearance.			X	
EXTRACTOR	DAILY	WEEKLY	MONTHLY	QUARTERLY

1. GENERAL (Overhaul Yearly)				
a. Check exterior finish for corrosion.				X

2. EXTRACTING UNIT				
a. Check screw and brush for wear.				X
b. Check screen for wear.				X

3. DRIVE				
a. Check reducer for noise and leakage.				X
b. Check bushing and screw shaft for wear.				X

Lubrication Chart	FREQUENCY	TYPE OF FITTING	LUBRICANT
Hydra-Extractor® speed reducer	6 months to 1 year	Oil fill plug	Amer. Worm Gear Oil (Amoco) Gear Oil 629 (Mobil)

Return Pump	DAILY	WEEKLY	MONTHLY	QUARTERLY
1. GENERAL				
a. Check exterior finish for corrosion				X
b. Check pump casing for wear				X
c. Check impeller for wear				X
2. DRIVE				
a. Check seals for leakage	X			
b. Check bearings for noise and wear				X

COMPONENT REMOVAL AND REPLACEMENT - The following steps are required in the removal and replacement of major components, assemblies, or piece parts necessary for corrective action.

*Use exploded view diagrams located in the exploded view sections of this manual.



CUTTING MECHANISM REMOVAL - See the Cutting Mechanism Section of this manual.

DRIVE MOTOR REMOVAL -

- After turning the circuit breaker off, remove cover on drive motor junction box and disconnect motor leads.
- Remove conduit from motor junction box.
- Remove the drive motor (4) from the slurry chamber assembly by removing four machine screws (5 & 6).

MECHANICAL SEAL REMOVAL -

- Remove spring and upper seal ring prior to removing motor.
- With motor removed push upward on Ni-Resist Seal until it can be removed.

MECHANICAL SEAL INSTALLATION -

- Clean the seal cavity and moisten the o-ring of the Ni-Resist Seal with soapy water.
- Tap the Ni-Resist Seal in the cavity with seal installation tool (part number 89711). The unpolished side of the seal (some marked with an X) must face down.
- Lubricate the upper seal ring and slip it over the drive shaft.
- Slide the retainer spring onto the shaft.

SECURITY RING REMOVAL -

- * Remove mounting bolts (8) and lift Security Ring Assembly out of machine.

REPLACEMENT OF SECURITY RING STATIONARY CUTTER BLOCK -

- * Remove stationary cutter block mounting screws (10) and replace stationary cutter block (9). Shim if needed to a clearance of 0.005" to 0.010".

IMPELLER REMOVAL -

- * Remove impeller hold down bolt (2) and carefully remove the impeller assembly (1) from the motor drive shaft with an impeller puller (Somat P/N 84150). Remove key (5) from shaft.

IMPELLER CUTTER EAR REPLACEMENT -

- * Remove two screws (7) that hold impeller cutter ear (6) to impeller (1).

NOTE: Screws may be loosened by gently heating with a propane torch.

IMPELLER CUTTER EAR RE-SHARPENING-

Rotating blades may be re-sharpened as cutting efficiency decreases. Remove impeller as described above. Remove attaching hardware for cutting ears. Using a gloved hand, firmly grasp blade and with an angle grinder, grind a new edge on interior of blade only. Interior of blade will face center bolt of impeller. The picture below has the edge to be resurfaced highlighted in black. DO NOT grind on opposing side of blade as this will reduce or impair any cutting ability.

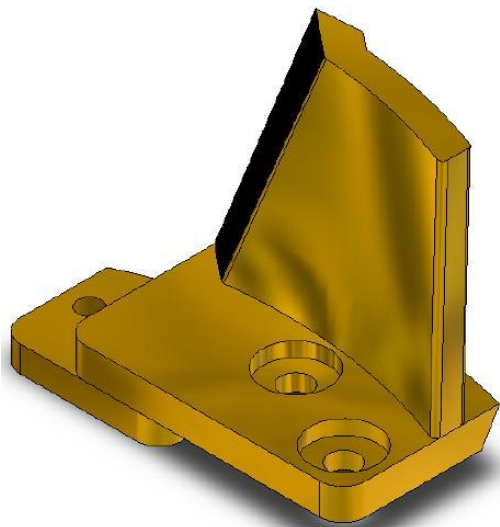

Grind ONLY on area highlighted in black

EXTRACTOR DRIVE MOTOR REMOVAL -

- After turning the circuit breaker off, remove cover on drive motor junction box and disconnect motor leads.
- Remove conduit from motor junction box.
- The drive motor (1) can be removed from the head assembly by removing four screws (3 & 4).

EXTRACTOR SPEED REDUCER REMOVAL -

- Remove bolt (6 & 7) and four machine screws (8, 9, and 10).
- Loosen four set screws in collar of reducer (5) to free it from the screw shaft (19).
- Access to the bottom two set screws can be gained by turning the reducer until the set screws line up with the openings in the side of the reducer. The reducer can now be lifted off the screw shaft.

EXTRACTOR SCREEN AND SCREW REMOVAL -

- After removing four machine screws (12, 13, & 14), from head assembly (11) lift head with screen (15) and screw assembly (19) attached, from the Hydra-Extractor® shell (27).
- By removing a machine screw (23, 24, 25), the plug cutter (22) can be removed from the screw assembly.
- Remove the screw assembly from the screen assembly by pulling the screw assembly through the bottom opening of the screen, while turning bottom of screw counter-clockwise with a pipe wrench.
- After removing the screw assembly, remove two button head machine screws (16, 17, 18), from the screen and slip the screen from the head assembly.

EXTRACTOR BOTTOM PIN REMOVAL -

- Remove six machine screws (44, 45, and 46).
- The bottom pin plate (41) with bottom pin (39) attached can now be removed.
- Remove screw (42 & 43). The bottom pin can now be separated from the bottom pin plate.

MP PUMP

REMOVAL AND INSTALLATION OF MECHANICAL SEAL or MOTOR

MECHANICAL SEAL:

1. Turn off power and lock out machine
2. Remove (4) 5/16-18 hex nuts from Impeller housing
3. Remove housing from pump-pak assembly
4. The impeller will now be visible, take care to **NOT** place anything in impeller vanes. This will cause damage to the vane and will not be covered under warranty.
5. Loosen 2 bolts holding drive sleeve to motor shaft.
6. Remove impeller with drive sleeve as an assembly, mechanical seal should come off with drive sleeve.
7. Replace mechanical seal. Install with raised carbon face towards motor. Take care to install straight onto sleeve. Install ceramic disc into adapter seat bore with polished side up. Take extreme caution to not damage polished side as this will cause immediate leaks. Ensure seal is seated to bottom of adapter seat bore. If needed use a wooden dowel and gently tap into place to ensure tight seat into bore.
8. Replace impeller assembly back onto motor shaft. Use a light coating of anti-seize on motor shaft to ensure smooth seating.
9. Push down onto impeller head using a gloved hand to reach a gap of .030 between the bottom of impeller to top of adapter.
10. Tighten sleeve clamp while maintaining .030 clearance
11. Check rotation of impeller to ensure proper seating and gap clearance
12. If rotation and clearance are ok, then replace housing to adapter
13. Install (4) 5/16-18 nuts and lock-washers onto studs and tighten to 15-ft.lbs.
14. Verify that impeller does **NOT** hit or scrape housing.

MOTOR REPLACEMENT:

1. Turn off power and lock out machine.
2. Remove (4) 5-16-18 hex head nuts from impeller housing
3. Remove housing from pump-pak assembly
4. Loosen 2 bolts holding drive sleeve to motor shaft
5. Remove impeller with drive sleeve as an assembly, taking care not to damage mechanical seal or pumping vanes
6. Remove (4) 3/8 – 16 x 3/4 hex head screws from adapter plate to motor.
7. Remove adapter unit from motor.
8. Replace motor as required properly wiring unit. Ensure that wiring is for correct voltage
9. Replace pump-pak as described in MECHANICAL SEAL REMOVAL SECTION #'s 8-14

Stenner Chemical Pump

Tube Replacement Instructions

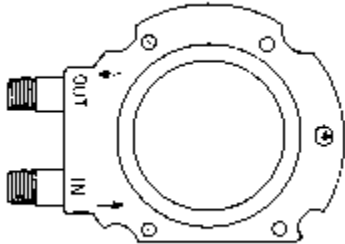

1. Remove the three cover screws. Lift the cover free.

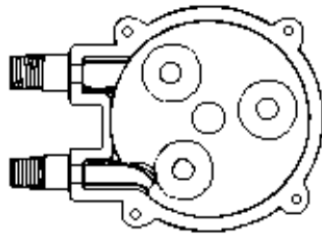

2. Set the Feed Rate Dial on #1. Turn the feeder switch on. Line up the slot in the roller assembly with the lower or "IN" tube fitting.

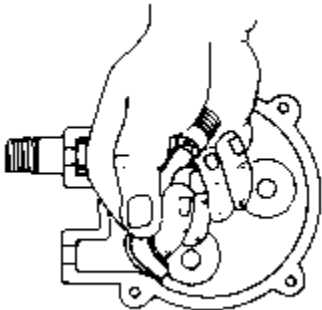

3. With the feeder dial set on #1, lift the tube housing out of the housing slot and pull it toward the center of the roller. Start the motor while pulling on the tube until it comes completely out of the housing. Turn the feeder off.

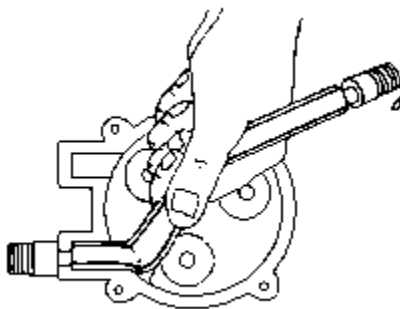

4. To install a new tube assembly, position the roller assembly until the slot is again in line with the "IN" or suction fitting (See drawing for roller position). Place the tube fitting into position and push the tube into the slot of the roller assembly. With the feed rate dial set on #1, start the motor and feed the tube into the slot as the roller assembly turns. Be careful of your fingers. Do not force the tube. Avoid kinks. When the roller assembly slot lines up with the "OUT" tube housing slot, quickly pull the tube

into position. Turn the feeder off.

5. Replace the cover and the three screws except the one over the "IN" tube fitting. Leave this screw loose enough to turn tube fitting for adjustment. NOTE: To obtain maximum tube life, the tube assembly must ride in the center of the rollers. To center the tube assembly on the rollers, set the feed rate dial on #10, turn the feeder on, turn the "IN" tube fitting not more than 1/8 of a turn in the direction which the tube must move. Observe the tube assembly. It should move toward the center of the rollers. If the tube moves further from the center of the rollers, turn "IN" tube fitting in the opposite direction until the tube centers. Turn the feeder off and tighten the tube housing cover screws left loose.

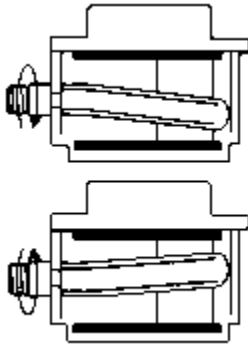

Major Components

Disassembly/Assembly Instructions

No tools are necessary

TO DISASSEMBLE:

1. Unplug feeder power cord and remove chemical lines.
2. Grasp the mechanical feed rate control section and turn it clockwise until it stops. Pull straight off shaft.
3. The tube housing complete can be removed from the feed rate control in the same manner

TO ASSEMBLE:

1. Align the mechanical feed rate control with the flat on the gear motor shaft. Push on straight. Turn the feed rate control until mounting rivets on gear motor fit into the keyhole slots in the feed rate control unit. Turn the feed rate control unit counter-clockwise until the snap lock engages. Insure the feed rate dial pointer is on the top.
2. Align the tube housing complete with the flat on the feed rate control output shaft. Push on straight. The mounting rivets will fit into the keyhole slots on the back of the tube housing complete.

TROUBLESHOOTING

SYMPTOM	POSSIBLE CAUSE	CORRECTIVE ACTION
Not enough water in Pulper.	<ol style="list-style-type: none"> 1. Water make up shut-off valve closed. 2. Low water pressure 3. Faulty operation of solenoid valve (see equipment schematic for location). 	<ol style="list-style-type: none"> 1. Open valve. 2. Increase "POT 1" setting to increase pre-fill. Increase "POT 2" setting to increase frequency of make-up water 3. Check for loose electrical connections. If the valve plunger is stuck or the coil is burned out, replace with a new valve.
SYMPTOM	POSSIBLE CAUSE	CORRECTIVE ACTION
Too much water in Pulper.	<ol style="list-style-type: none"> 1. Trough valve open too far 2. Misadjusted PLC POT setting. 3. Faulty operation at valve. (see equipment schematic for location.) 4. Overflow fitting and line clogged. 	<ol style="list-style-type: none"> 1. Throttle down valve to decrease water in pulper and increase water in extractor (more overflow) 2. The PLC controls the circuit to the solenoid valve. Too high a setting would tend to hold the solenoid valve open too long letting too much water into the Pulper. Adjust POT 2 to correct the problem. 3. Repair or replace solenoid valve. 4. Clean fitting and line.

SYMPTOM	POSSIBLE CAUSE	CORRECTIVE ACTION
<p>Pulper operates but pulping rate is low.</p>	<ol style="list-style-type: none"> 1. Plugging of sizing ring. 2. Worn or missing impeller blades. 3. Worn or missing stationary blades. 4. Excessive foaming. 5. Sluggish vortex due to: <ol style="list-style-type: none"> a. Too little water in Pulper. b. Overload of waste. 6. Clogged or worn pump. 7. Clogged slurry lines. 	<ol style="list-style-type: none"> 1. Check stationary blades and ears. If dull, replace. Refer to Pulper maintenance section. Check water level control - it may be adjusted too low. See previous section. 2. Refer to Pulper maintenance section for replacement procedure. 3. Adjust or replace blades in accordance with Pulper maintenance section of manual. 4. Add a de-foamer or any other suitable commercial preparation. (See Section 5.) 5. (See below) <ol style="list-style-type: none"> a. See Previous section. b. Revise waste feeding rate (see Feeding Instructions, Section 4). 6. See pump section for require corrective action. 7. Check individual cleanouts for loss of pressure to locate blockage. Remove blockage.

SYMPTOM	POSSIBLE CAUSE	CORRECTIVE ACTION
<p>Pulper operates but pulping rate is low.</p>	<ol style="list-style-type: none"> 1. Plugging of sizing ring. 2. Worn or missing impeller blades. 3. Worn or missing stationary blades. 4. Excessive foaming. 5. Sluggish vortex due to: <ol style="list-style-type: none"> a. Too little water in Pulper. b. Overload of waste. 6. Clogged or worn pump. 7. Clogged slurry lines. 	<ol style="list-style-type: none"> 1. Check stationary blades and ears. If dull, replace. Refer to Pulper maintenance section. Check water level control - it may be adjusted too low. See previous section. 2. Refer to Pulper maintenance section for replacement procedure. 3. Adjust or replace blades in accordance with Pulper maintenance section of manual. 4. Add a de-foamer or any other suitable commercial preparation. (See Section 5.) 5. (See below) <ol style="list-style-type: none"> a. See Previous section. b. Revise waste feeding rate (see Feeding Instructions, Section 4). 6. See pump section for require corrective action. 7. Check individual cleanouts for loss of pressure to locate blockage. Remove blockage.

SYMPTOM	POSSIBLE CAUSE	CORRECTIVE ACTION
Hydra-Extractor® stops frequently.	1. Worn Screw.	1. Replace screw.
Heavy flow from overflow pipe.	1. Excessive foaming 2. Blockage of return line. 3. Improper Return water flow.	1. Add a de-foamer. (See Section 5) 2. Check individual cleanouts to locate blockage. Locate blockage. Remove blockage. 3. Readjust throttling valves.
Excessively wet pulp discharge from Hydra-Extractor®.	1. Blockage of screen. 2. Worn screw and brush.	1. Clean the Hydra-Extractor® screen. Refer to Hydra-Extractor® Maintenance Section of the manual. 2. Send worn screw back to SOMAT Company for repair. Remove screw and replace. Refer to Hydra-Extractor® Maintenance Section of this manual.
SYMPTOM	POSSIBLE CAUSE	CORRECTIVE ACTION
Hydra-Extractor® stops frequently.	1. Worn Screw.	1. Replace screw.
Heavy flow from overflow pipe.	1. Excessive foaming 2. Blockage of return line. 3. Improper Return water flow.	1. Add a de-foamer. (See Section 5) 2. Check individual cleanouts to locate blockage. Locate blockage. Remove blockage. 3. Readjust throttling valves.

Excessively wet pulp discharge from Hydra-Extractor®.	1. Blockage of screen.	1. Clean the Hydra-Extractor® screen. Refer to Hydra-Extractor® Maintenance Section of the manual.
	2. Worn screw and brush.	2. Send worn screw back to SOMAT Company for repair. Remove screw and replace. Refer to Hydra-Extractor® Maintenance Section of this manual.

SYMPTOM	POSSIBLE CAUSE	CORRECTIVE ACTION
Decreased pulping rate or excessive unpulped material left in Pulper tank after shut down.	Dull stationary cutter block or impeller cutter ear, or excessive clearance between the two.	Replace the dull stationary cutter block and impeller cutter ear and/or shim the impeller cutter ear so that the proper clearance is maintained.
Impeller jams when Pulper is stopped and will not restart.	The clearance between the security ring and the impeller assembly is excessive.	Replacement of the impeller assembly and/or the security ring is required.
Slight clicking sound when machine is operating.	Impeller cutter ear may be loose.	Tighten the hex head bolts that hold the impeller cutter ear. Use Loctite red.
SYMPTOM	POSSIBLE CAUSE	CORRECTIVE ACTION
Decreased pulping rate or excessive unpulped material left in Pulper tank after shut down.	Dull stationary cutter block or impeller cutter ear, or excessive clearance between the two.	Replace the dull stationary cutter block and impeller cutter ear and/or shim the impeller cutter ear so that the proper clearance is maintained.
Impeller jams when Pulper is stopped and will not restart.	The clearance between the security ring and the impeller assembly is excessive.	Replacement of the impeller assembly and/or the security ring is required.
Slight clicking sound when machine is operating.	Impeller cutter ear may be loose.	Tighten the hex head bolts that hold the impeller cutter ear. Use Loctite red.

SYMPTOM	POSSIBLE CAUSE	CORRECTIVE ACTION
No water delivered	<ol style="list-style-type: none"><li data-bbox="597 149 846 226">1. Impeller worn or clogged.<li data-bbox="597 317 808 344">2. Clogged lines	<ol style="list-style-type: none"><li data-bbox="1042 149 1406 226">1. Check impeller, clean or replace as required.<li data-bbox="1042 260 1446 430">2. Check individual cleanouts for loss of pressure to locate blockage. Remove blockage.
Seal Leaking	<ol style="list-style-type: none"><li data-bbox="597 474 927 552">1. Worn or damaged seal or motor	<ol style="list-style-type: none"><li data-bbox="1042 474 1422 552">1. Check seal and motor shaft. Replace as required.

REPLACEMENT PARTS & EXPLODED VIEWS

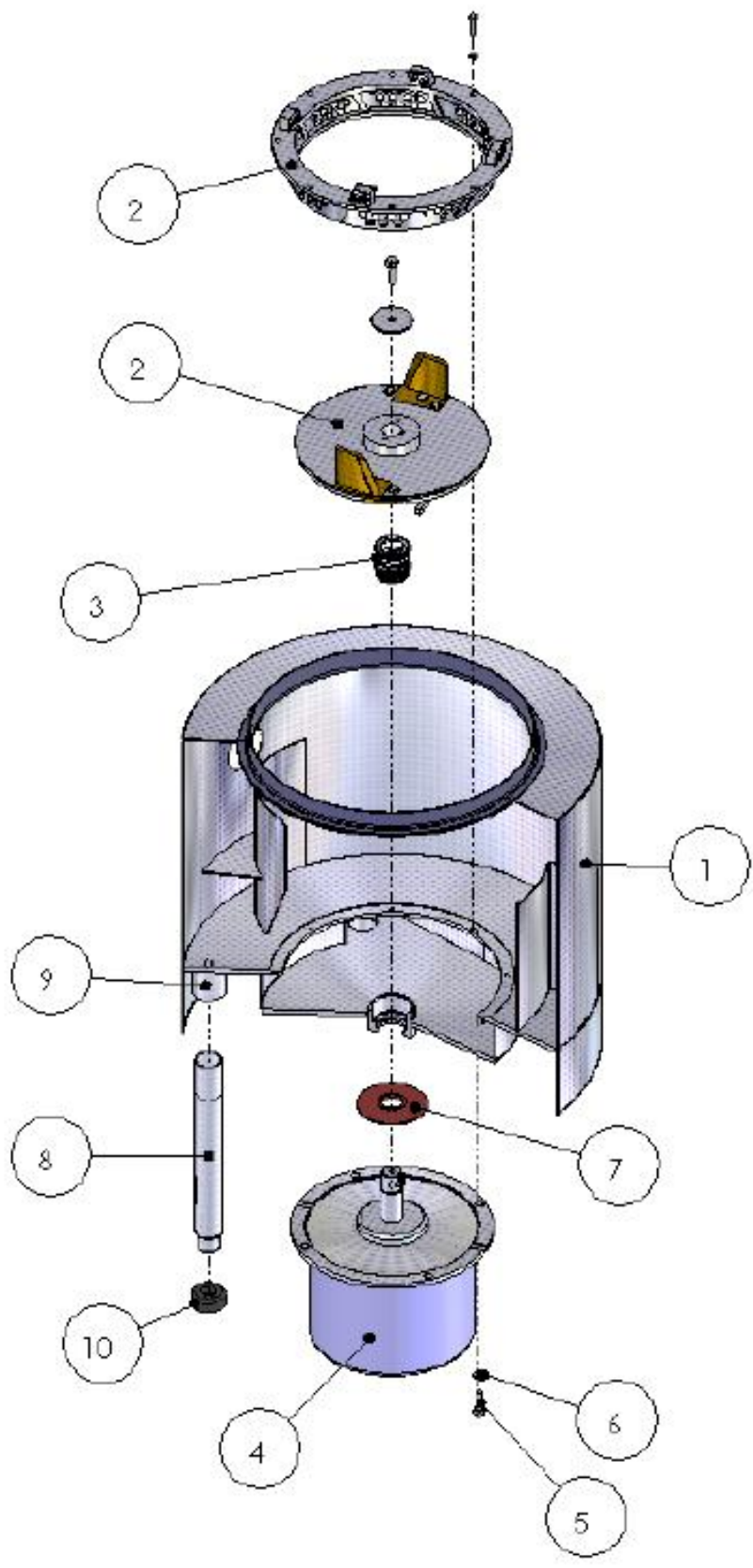

SPC-75 PULPER PARTS LIST

Figure & Item #	Description	Part Number	Required
1	Shell and slurry chamber		1
2	Cutting mechanism (see cutting mechanism)		1
3	Seal, Mechanical	54325	1
4	Motor, 7.5HP	41734	1
	Motor Attaching Parts: ↓		
5	Screw, Hex	½-13 x 1-1/4	4
6	Lock washer	½ ID	4
7	Flinger	32460	1
8	Leg, adjustable	39705	4
9	Set screw	¼-20 x 3/8	4
10	Vibration Isolator	16200	4
	Items Not Shown		
High Tank Only			
	Lid latch	35100	1
	Lid hinge	35613	2
	Limit switch, magnetic	54999-1	1*
	Magnet	55005	1*
UDT ONLY			
	UDT Lid	84772-1	1
	UDT Gasket	SP75-UDTGASKET	1
	UDT Cone	57316-1	1
	UDT Clamp Ring	SP75-UDTCLAMPRING	4
	Limit switch, in-tube style	59942	1*
	Limit switch cord	59943	1
	Pipe Cap	20469	1
	Nipple	43041	1
	Elbow	26850-1	1
TRAY ONLY			
	Curtain (23-3/4 x 13")	23070	1
	Curtain (22 x 11")	1531068	1
TROUGH ONLY			
	Trough gasket (9")	82781	1
	Trough gasket (12")	82780	1
TOOLS			
	Impeller puller	84150	1

*Recommended spare part

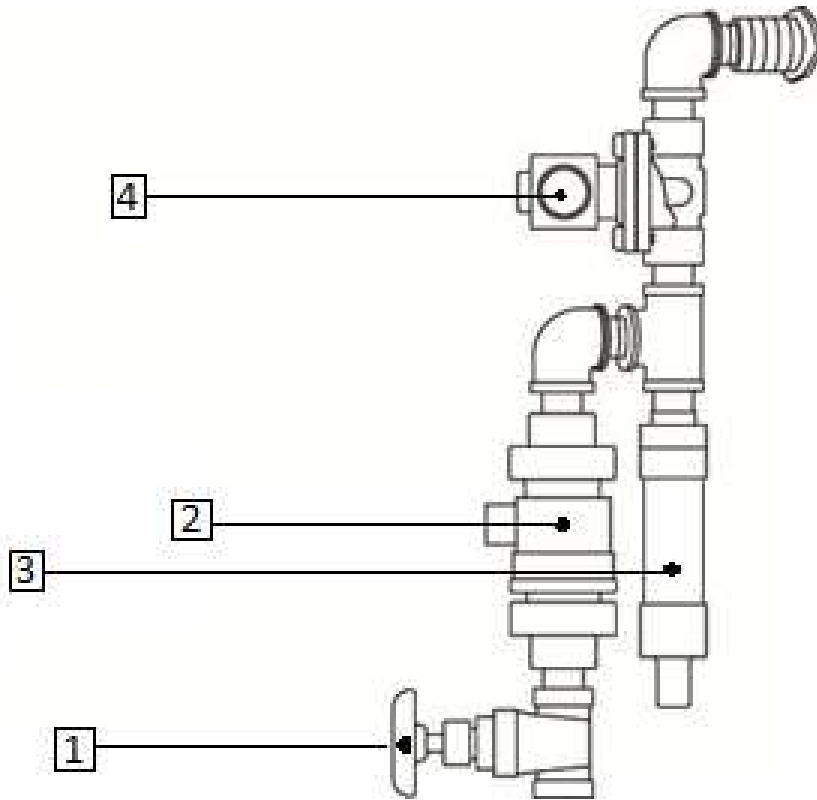

SPC-75 PULPER PLUMBING PARTS LIST

Figure	Description	Part Number	Required
1	½" Gate valve	64803	2
2	½" Backflow preventer	11310	2*
3	½" Shock arrestor	11303	2
4	½" Solenoid valve	64710	2*
Not Shown			
	2" Motor Operated Valve	64742	1
	1-1/2" Gate valve	64825	2

*Recommended spare part

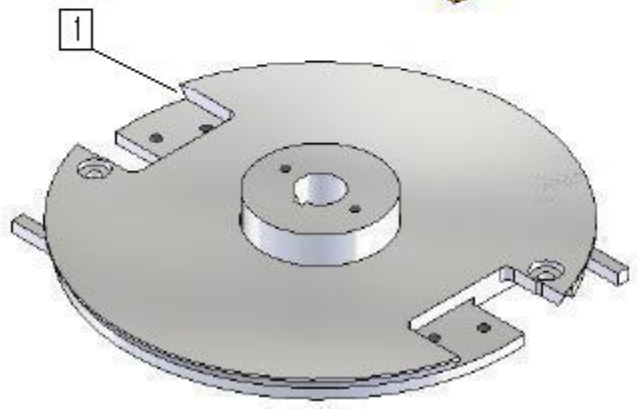
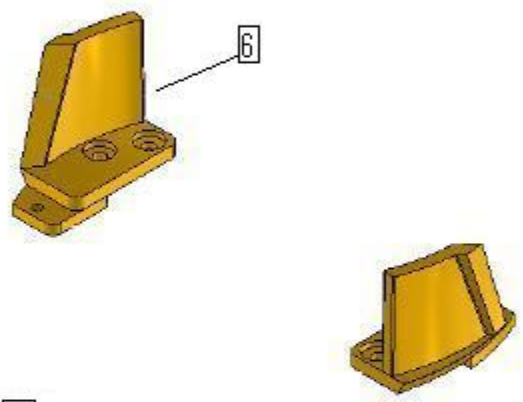
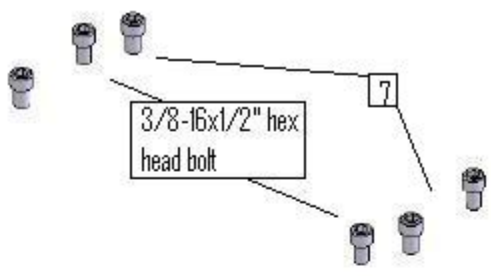
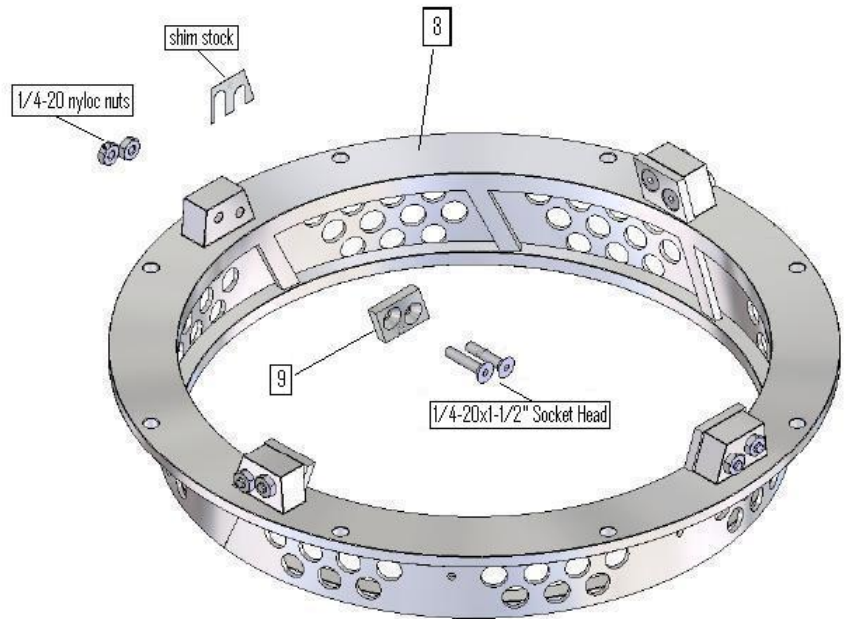

SPC-75 HY-POINT CUTTING MECHANISM

PARTS LIST

ITEM	DESCRIPTION	PART NUMBER	QUANTITY
1	Impeller	85576	1
	Impeller Attaching Parts ↓		
2(not shown)	Screw, hex	½-13 x 1-1/4"	1
3(not shown)	Lock washer	½" ID	1
4(not shown)	75 Impeller washer	89201	1
5(not shown)	Key stock	5/16x5/16x1	1
6	Rotating blade	24975	2*
	Rotating Blade Attaching Hardware ↓		
7	Screw, hex	3/8-16 x 5/8"	6*
8	Security ring assembly, with blades	87075	1
9	Stationary blades	80988	4*
	Stationary Blade Attaching Hardware ↓		
10	Screw, socket head, flat	¼-20 x 1-1/4"	2 ea blade*

*Recommended spare part

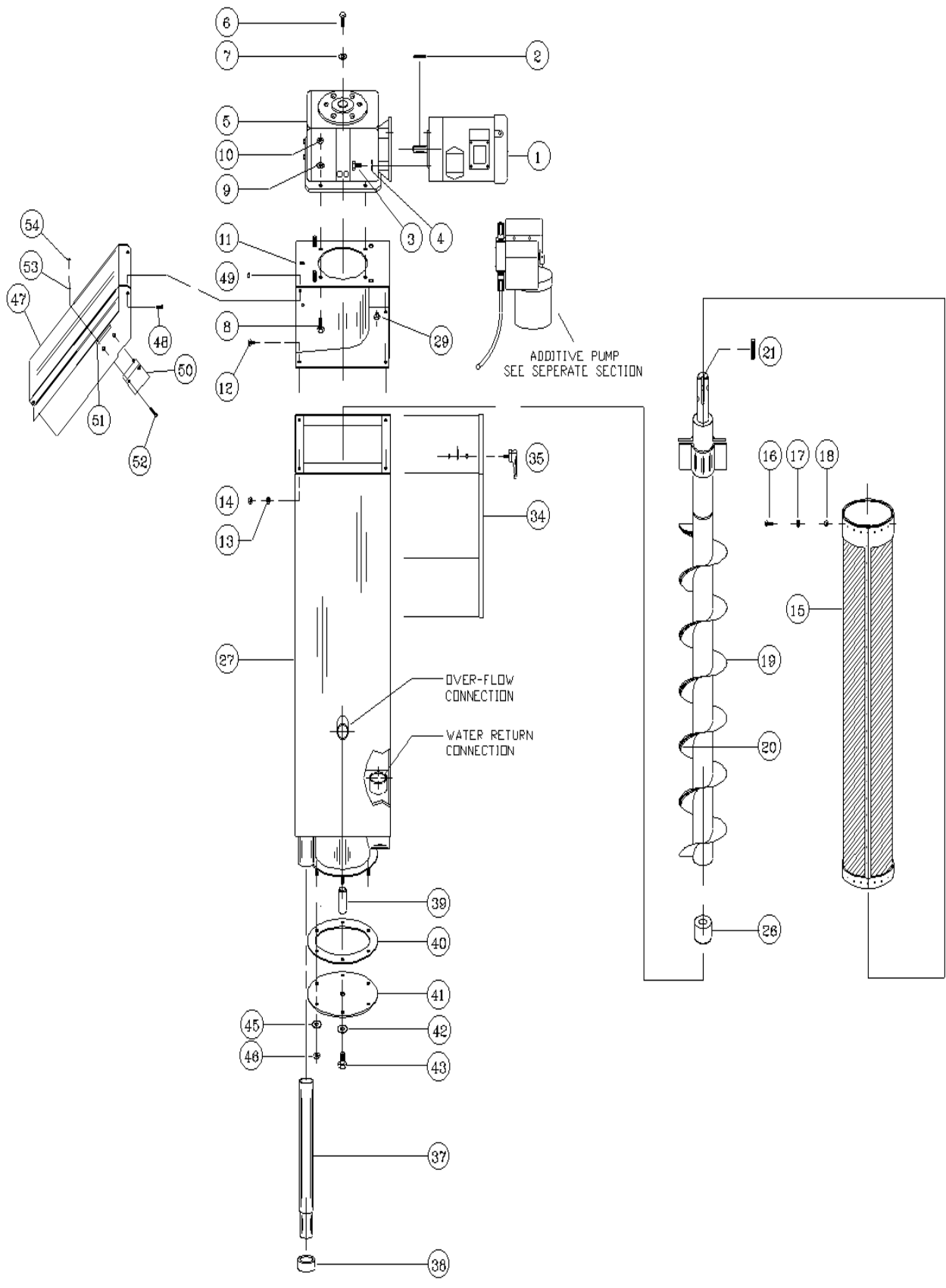

SPC-75 HYDRA-EXTRACTOR PARTS LIST

ITEM	DESCRIPTION	PART NUMBER	QUANTITY
1	Drive Motor, 2HP	41631	1
2	Key stock	3/16x3/16x1-5/8"	1
3	Bolt, hex	3/8-16 x 3/4"	4
4	Lock washer	3/8 ID	4
5	Gear reducer, 2HP	51687-3	1
	Gear Reducing Attaching Parts ↓		
6	Bolt, hex	3/8-16 x 1"	1
7	Washer, flat	3/8"ID x 2"OD	1
8	Screw, hex	3/8-16 x 1-1/4"	4
9	Lock washer	3/8" ID	4
10	Nut, hex	3/8-16	4
11	Head assembly	89306	1
	Head Assembly Attaching Parts ↓		
12	Screw, hex	5/16-18 x 1/2"	4
13	Lock washer	5/16" ID	4
14	Nut, hex	5/16-18	4
15	Screen assembly	54005	1*
	Screen Assembly Attaching Parts ↓		
16	Screw, buttonhead	5/16-18 x 1/2"	2
17	Lock washer	5/16" ID	2
18	Nut, hex	5/16-18	2
19	Screw assembly	86820	1*
20	Brush, nylon	16000	4
21	Key stock	3/8 x 3/8 x 3"	1
22-25	No part		
26	Bushing, lower	81350	1*
27	Shell, weldment	89306	1
28	Not available		
29-33	No part		
34	Access cover	80020	1
35	Lid fastener	35202-1	1
36	Vibration isolator	16200	2

ITEM	DESCRIPTION	PART NUMBER	QUANTITY
37	Leg, adjustable	39706	2
38	No Part		
39	Bottom Pin	81055	1*
40	Gasket, bottom plate	82786	1
41	Bottom plate	81025	1
	Bottom Pin Attaching Parts ↓		
42	Washer, flat	½" ID	1
43	Screw, hex	½-13 x 1"	1
44	Screw, hex	3/8-16 x 1"	6
45	Lock washer	3/8" ID	6
46	Nut, hex	3/8-16	6
47	Discharge Chute	81531	1
	Discharge Chute Attaching Parts ↓		
48	Screw, round head	10-32x ¾"	2
49	Nut, hex	10-32	2
50	Limit switch, magnetic	54999-1	1
	Limit Switch Attaching Parts ↓		
51	Magnet, high energy	55007	1
52	Screw, round head	10-32 x 1-1/4	2
53	No part		
54	Nut, nyloc	10-32	2
55(not shown)	Rubber hose to return pump	26805-1	

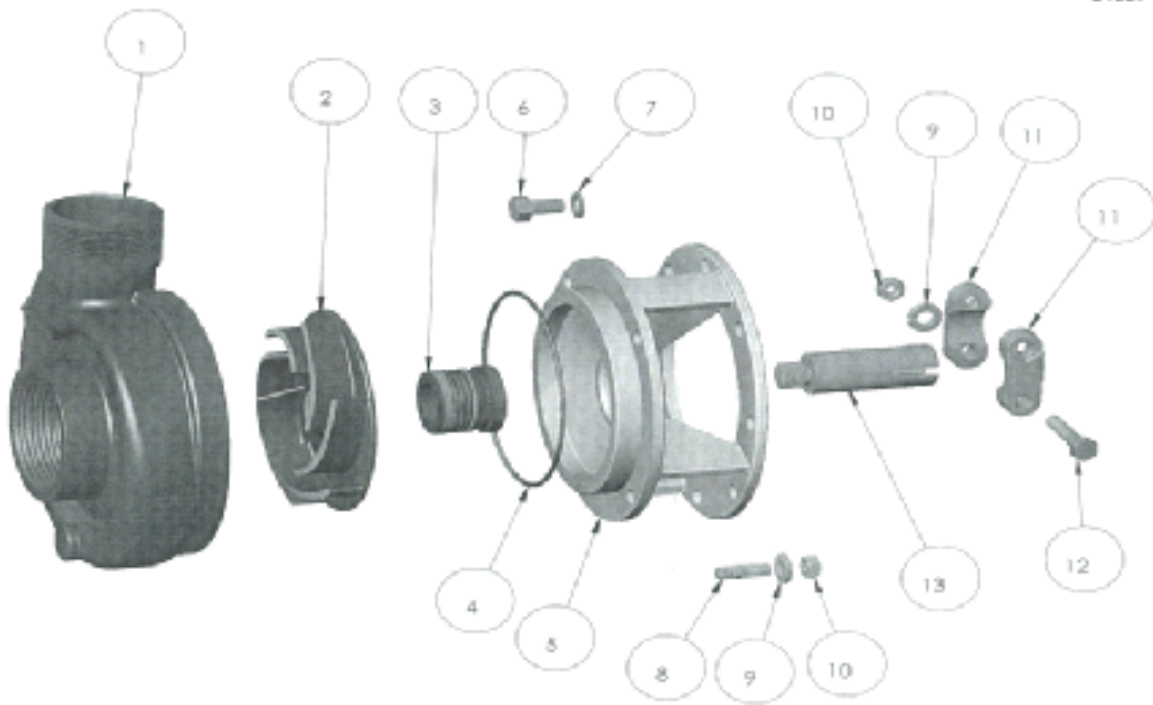

MP PUMP REPLACEMENT PARTS LIST

ITEM	DESCRIPTION	PART NUMBER	QUANTITY
1	Housing	MP34520	1
2	Impeller	MP34631**	1
3	Mechanical Seal 1"	MP22272*	1*
4	O Ring	MP34555	1
5	Spacer Ring	MP34521	1
6	Screw, hex	3/8-16 x 3/4	4
7	Lock washer	3/8" ID	4
8	Stud	5/16-18 x 1"	4
9	Lock washer	5/16" ID	4
10	Nut, hex	5/16-18	4
11	Clamp, S.S.	5/16"	2
12	Screw, hex	5/16-18 x 1-3/4"	2
13	Drive sleeve	MP30670**	1

*Recommended spare part

**Item comes as one piece assembly, not individual parts

SOMAT ELECTRICAL PANEL

Due to the inherently involved and potentially dangerous nature of all electrical control equipment, Somat Company recommends maintenance and repair of the Som-A-Trol be performed by qualified personnel only. Qualified personnel should find the electrical drawings supplied to be sufficient guidance for troubleshooting.