



## Diaphragm Valves SDV Series

are ideally suited for Shut-off, Flow Control and Throttling of corrosive and abrasive process media in either liquid or gaseous state.

### Modular Design

Diaphragm Valves SDV Series are available as DIN- or ANSI-Valves, with handwheel for manual operation as per standard.

The sturdy design bodies are made of cast steel 1.0619 (WCB), coating RAL 5005 signal-blue or stainless steel casting 1.4408 (CF-8M), with resistant linings such as PFA or PFA-AS (anti-static).

Proven PTFE/EPDM-diaphragms assure faultless closing function at any time.



### Main Features

- Heavy-duty, robust construction, maintenance-free
- Bubble-tight shut-off throughout the full pressure and temperature range
- Spindle protected against atmospheric corrosion
- Force limiting device protecting diaphragm from cold flow and other deformations, high life cycle
- Yellow sight indicator showing actual position of diaphragm
- Easy replacement of components on site
- Flanges acc. to DIN PN10/16 resp. ANSI 150lbs for installation into existing piping systems

**CE** Conformity according to European Pressure Equipment Directive 97/23/EC (PED)

### Options



#### Sliding Spindle

Body 1.0619/PFA, for external actuators



#### Automated Valve

Body CF-8M/PFA, with pneum. actuator, el. position indicator and solenoid valve



#### Automated Valve

with el.-pneum. positioner

# SDV: Technical Data, Construction

21 Diaphragm Valves, plastomer-lined

PM 21 M.01 e

March 2006



## Operating Conditions

- Temperature range from  $-30^{\circ}\text{C}$  up to  $+150^{\circ}\text{C}$  (depending on lining material)
- Pressure range from 13.33 mbar up to 16 bar (depending on size)

## Testing / Marking

- Pressure- and tightness testing acc. to EN 12266-1, leakage rate A, and spark testing at 35 kV to assure lining integrity. Marking of valves on body and name plate acc. to EN 19.
- Material- resp. test certificate acc. to EN 10204-3.1

## Construction of Valve

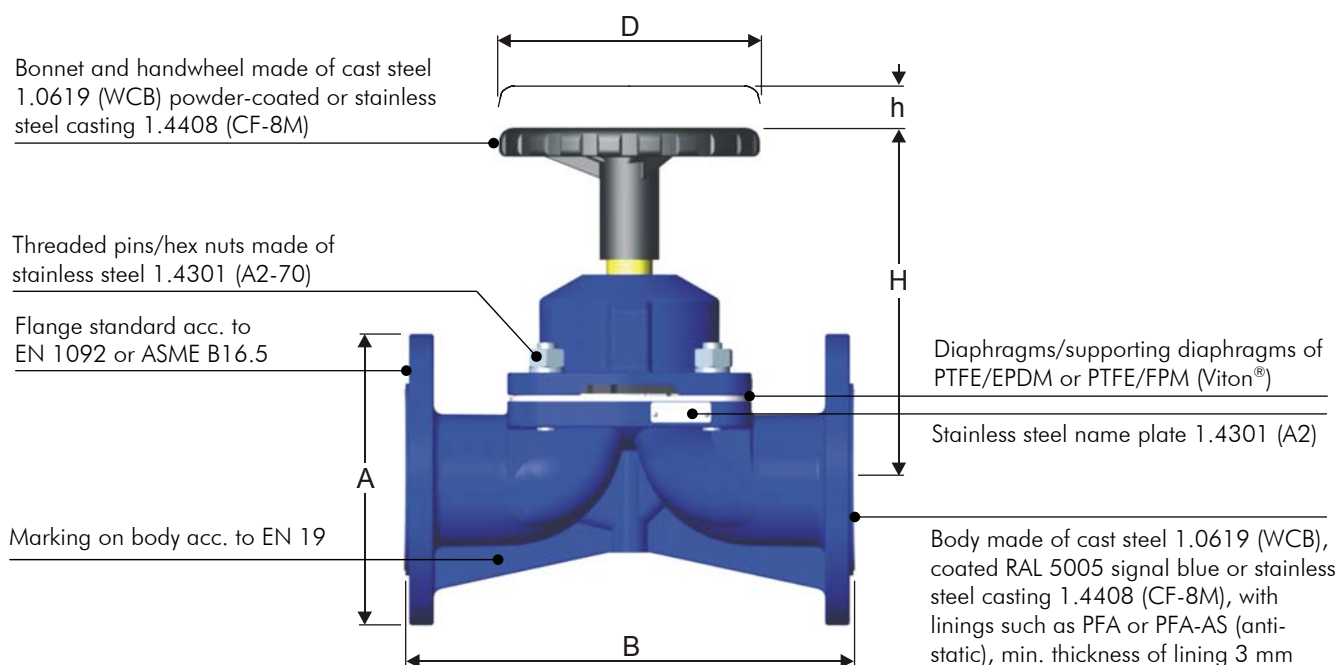

## Technical Data

Dimensions in mm (usg/min. = m<sup>3</sup>/hr x 1.16)

DN	A DIN	A ANSI	B DIN	B ANSI	D	H	h Stroke	Revol. per stroke	kg	PS max. bar	Closing Force (N)	Kv-Value (m <sup>3</sup> /hr)
15/1/2"	95	95	130	130	85	115	8	4.5	2.5	16	1'900	7.8
20/3/4"	105	105	150	150	85	117	8	4.5	3.0	16	2'400	10.0
25/1"	115	108	160	146	85	124	10	5.5	3.8	16	2'900	15.0
32/1 1/4"	140	140	180	180	85	134	12	7.0	5.2	16	3'600	22.5
40/1 1/2"	150	127	200	174	120	173	24	12.0	7.4	16	4'400	37.0
50/2"	165	152	230	200	120	186	30	15.0	9.7	16	6'000	65.0
65/2 1/2"	185	185	290	290	180	208	30	12.0	13.5	10	7'800	95.0
80/3"	200	190	310	260	180	233	34	13.5	18.0	8	9'100	134.0
100/4"	220	229	350	327	250	282	40	13.5	30.0	7	11'400	200.0
125/5"	250	250	400	400	250	345	52	17.5	43.0	7	17'000	320.0
150/6"	285	279	480	416	400	412	60	15.0	66.0	7	33'300	452.0
200/8" <sup>1)</sup>	340	340	600	600	400	442	90	22.5	122.0	5	43'500	650.0

Face to face B acc. to DIN EN 558-1 range 1, ANSI-Valves acc. to US standard (1/2", 3/4", 1 1/4", 2 1/2", 5", 8" acc. to EN 558-1 range 1

<sup>1)</sup> above PS max. 3 bar: supplier to be contacted



**Pressure-/Temperature Diagram**

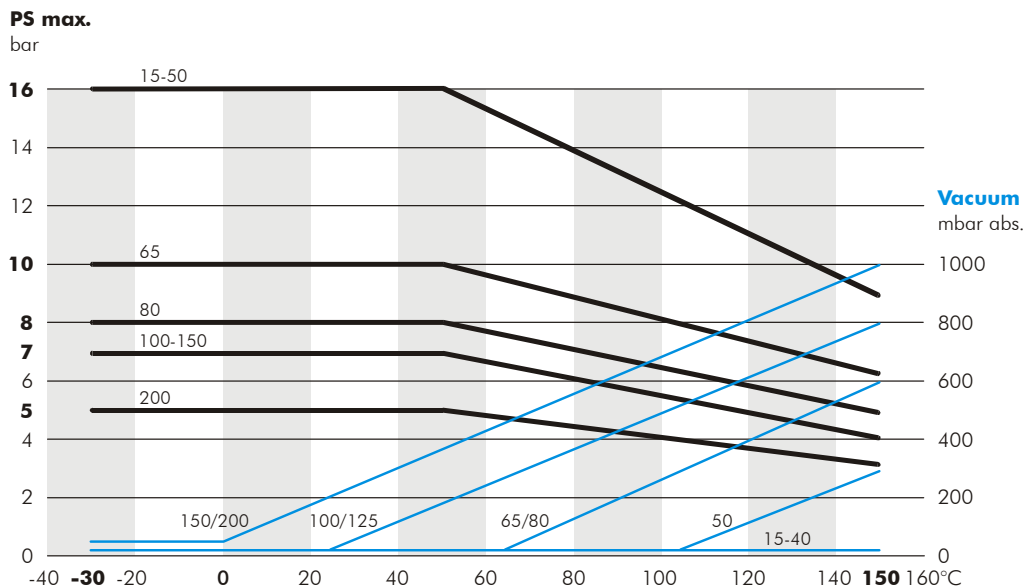

**Bonnet Option**

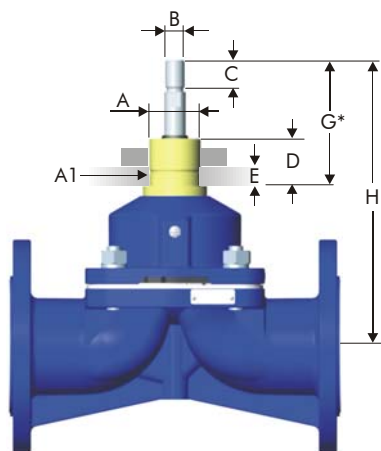

**Type Ss**  
 Bonnet with sliding spindle for easy actuation with pneumatic or electric actuators (not suitable for Swissfluid type actuators)

**Dimensions** in mm

DN	A	A1	B	C	D	E	G*	H	H1*
15/1/2"	M30x1.5	32	M12	26	26	10	110	168	223
20/3/4"	M30x1.5	32	M12	26	26	10	110	170	225
25/1"	M30x1.5	32	M12	26	26	10	110	179	229
32/1 1/4"	M30x1.5	32	M12	26	26	10	110	190	239
40/1 1/2"	M40x1.5	40	M16	28	35	12	110	208	284
50/2"	M40x1.5	40	M16	28	35	12	110	221	291
65/2 1/2"	M48x1.5	48	M18x1.5	35	38	12	110	232	335
80/3"	M48x1.5	48	M18x1.5	35	38	12	110	257	356
100/4"	M52x1.5	52	M24x2	35	38	12	110	290	430
125/5"	M52x1.5	52	M24x2	35	38	12	110	305	443
150/6"	M62x1.5	62	M30x2	35	38	12	110	357	564
200/8"	M62x1.5	62	M30x2	35	38	12	110	432	564

\* Valve in closed position



**Construction of Linear Stroke Actuator** Sectional view and accessories

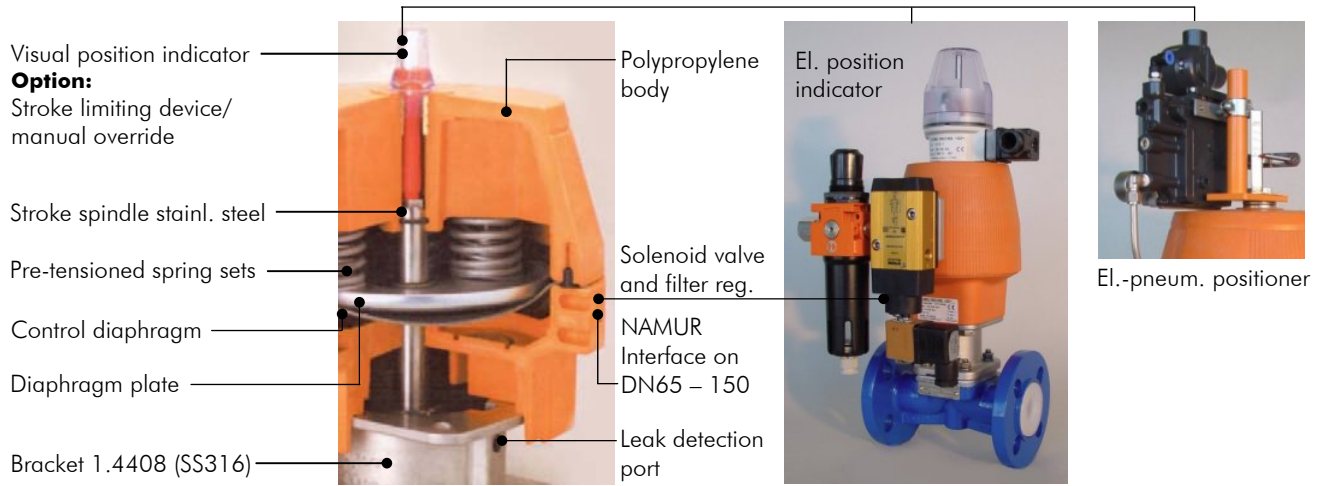

**Mounting Options** Dimensions in mm (lbs = kg x 2.2)

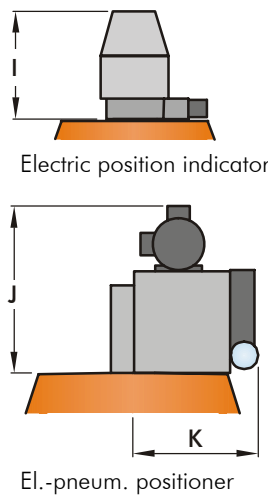
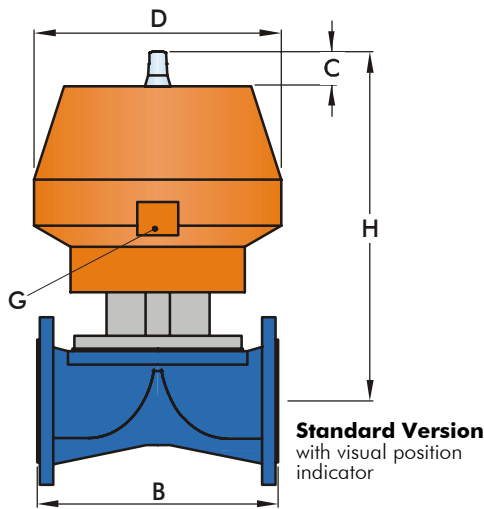

**Accessories**

- Electric position indicator
- Adapter mounting kit  
must be applied if valve with stroke limiter and manual override is combined with an electric position indicator
- Stroke limiter/manual override
- Mounting flange kit for el.-pneum. positioner
- Electro-pneum. positioner
- 3/2-way solenoid valve for single-acting actuators
- 5/2-way solenoid valve for double-acting actuators
- Pneum. positioner
- NAMUR adapter plate

DN	B DIN	B ANSI	C	D	G	H	I	J	K	kg
15/1/2"	130	130	22.5	96	1/8"	211	100	233	190	4.8
20/3/4"	150	150	22.5	96	1/8"	213	100	233	190	5.3
25/1"	160	146	22.5	96	1/8"	227	100	233	190	6.4
32/1 1/4"	180	180	35.5	120	1/8"	253	100	233	190	7.8
40/1 1/2"	200	174	35.5	150	1/4"	284	100	233	190	13.9
50/2"	230	200	35.5	150	1/4"	302	100	233	190	16.0
65/2 1/2"	290	290	46	280	1/8"	366	129	233	190	19.8
80/3"	310	260	46	280	1/8"	373	129	233	190	32.8
100/4"	350	327	46	335	1/8"	448	129	233	190	46.7
125/5"	400	400	46	335	1/8"	533	129	233	190	60.0
150/6"	480	416	46	335	1/8"	620	129	233	190	84.0
200/8"	600	600	-	-	-	-	-	-	-	-

Standard Version w/o stroke limiter and manual override



**Modes of Operation**

**FC: Single-acting (Spring to close)**

In the de-energized state, the valve is **closed** by spring force. When the control media is admitted to the actuator (connection **A**), the valve opens; as soon the control media escapes, the valve is closed again by spring force.

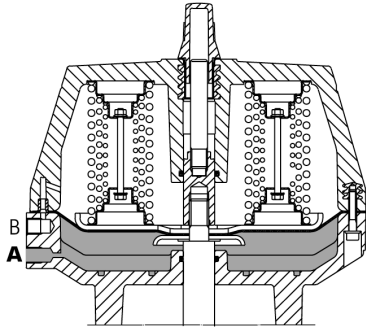

**FO: Single-acting (Spring to open)**

In the de-energized state, the valve is **opened** by spring force. When the control media is admitted to the actuator (connection **B**), the valve closes; as soon the control media escapes, the valve is opened again by spring force.

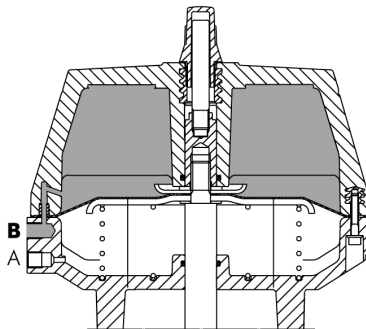

**DA: Double-acting**

The valve has no defined position, it is **opened** and **closed** by applying control air pressure to the corresponding **control connections**, i.e. connection **A** for open, connection **B** for close.

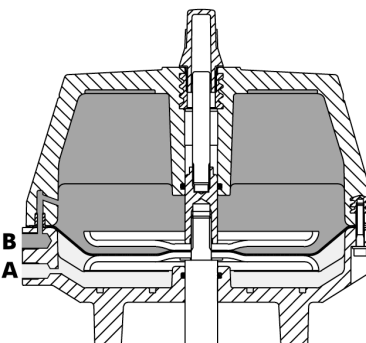

**Air Supply Diagrams**

Guide lines, lower air pressures are possible by reducing the spring force.

- Control media: inert, non-aggressive gases
- Temperature of control media: max. 40°C

**FC: Single-acting (Spring to close)**

Air supply allowable max. 7 bar

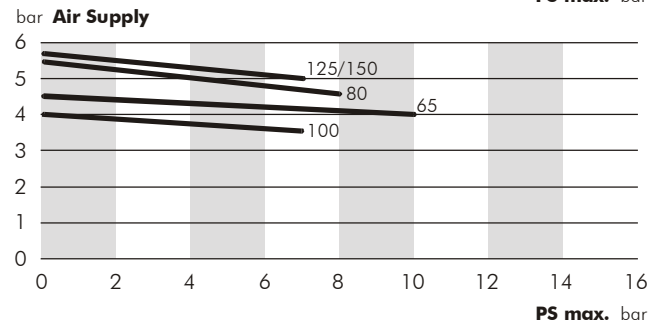
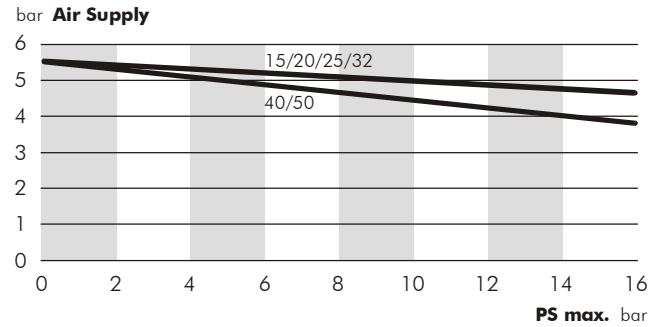

**DA: Double-acting  
FO: Single-acting (Spring to open)**

Air supply allowable max. 5 bar

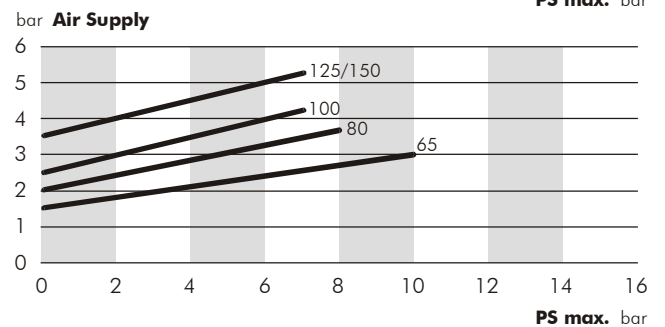
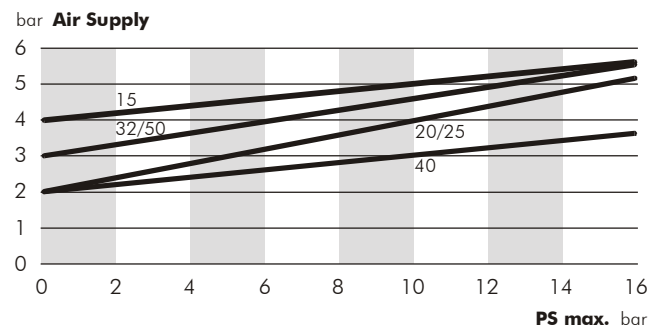



**Standard Version** (Picture showing DN 80 PN16, PFA-lined, with handwheel)

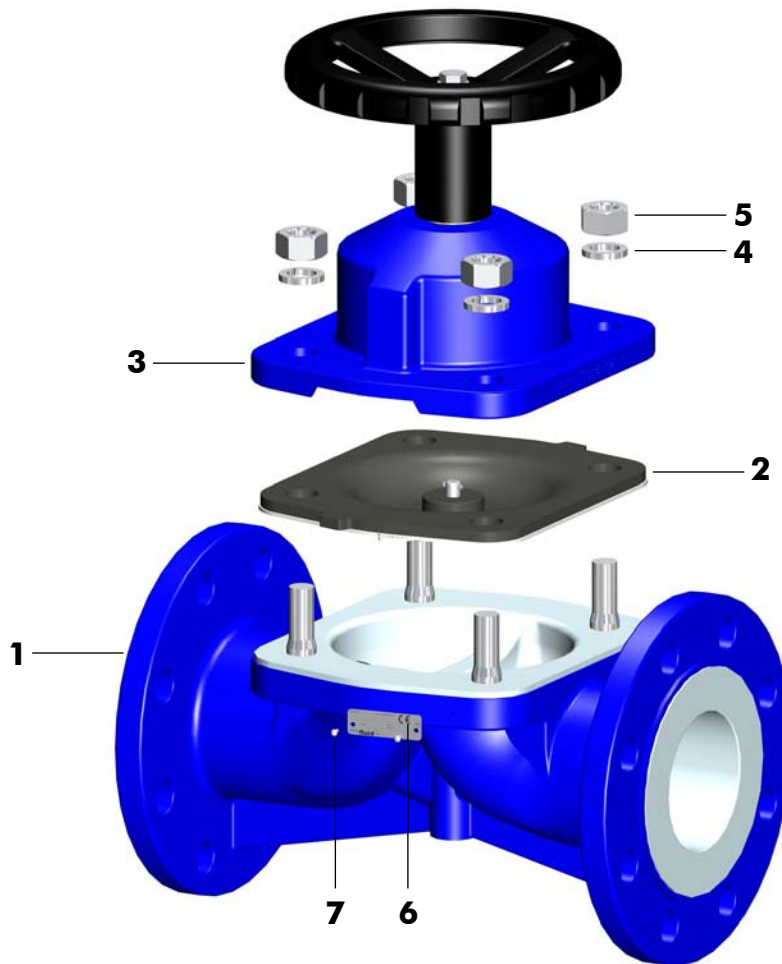

Item	Qty.	Description	Material	No.
1	1	Body PFA-lined, RAL 5005	WCB	1.0619
2	1	Diaphragm complete	PTFE/EPDM	
3	1	Bonnet complete RAL 5005, with handwheel RAL 9004	WCB	1.0619
4	4	Spring Washer	A2	1.4310
5	4	Hex. Nut	A2-70	1.4310
6	1	Name Plate 42 x 14 CE	A2	1.4301
7	2	Hammer Screw 2.49 x 4.76	A2	1.4310

**SDV: Parts List Bonnet compl.**

21 Diaphragm Valves, plastomer-lined

**PM 21 M.06 e**

March 2006



**Standard Version** (Picture showing DN 80, with handwheel)

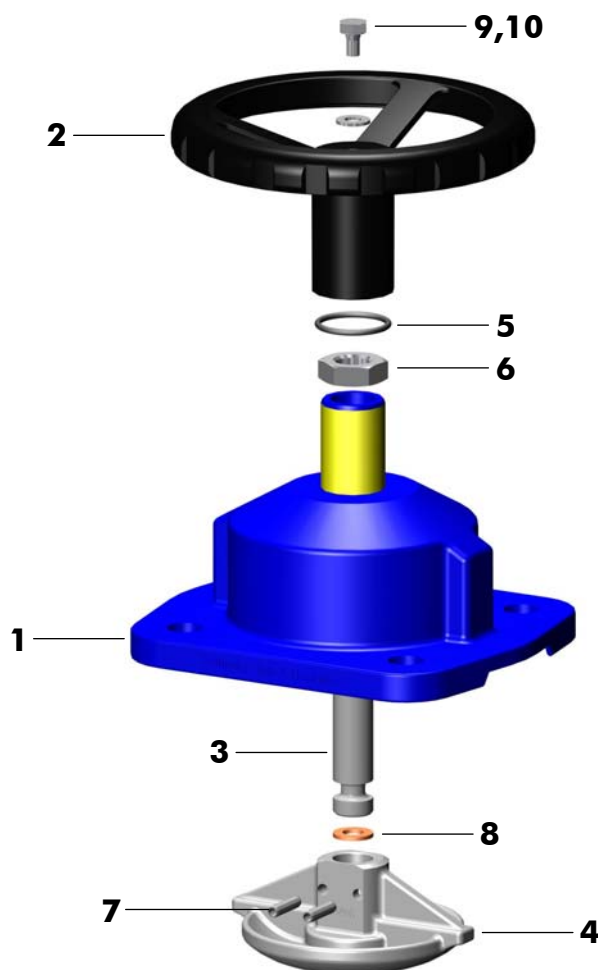

Item	Qty.	Description	Material	No.
1	1	Bonnet, RAL 5005	WCB	1.0619
2	1	Handwheel, RAL 9004	WCB	1.0619
3	1	Spindle	A2	1.4305
4	1	Compressor Plug Bayonet	CF-8M	1.4408
5	1	O-Ring Handwheel	NBR	
6	1	Hex. Nut	A2	1.4310
7	2	Spring Tension Pin	A2	1.4310
8	1	Spacer	Ms60Pb	2.0371
9	1	Spring Washer	A2	1.4310
10	1	Hex. Head Screw	A2-70	1.4310



**Standard Version** (Picture showing DN 80 PN16, PFA-lined, actuator with visual position indicator)

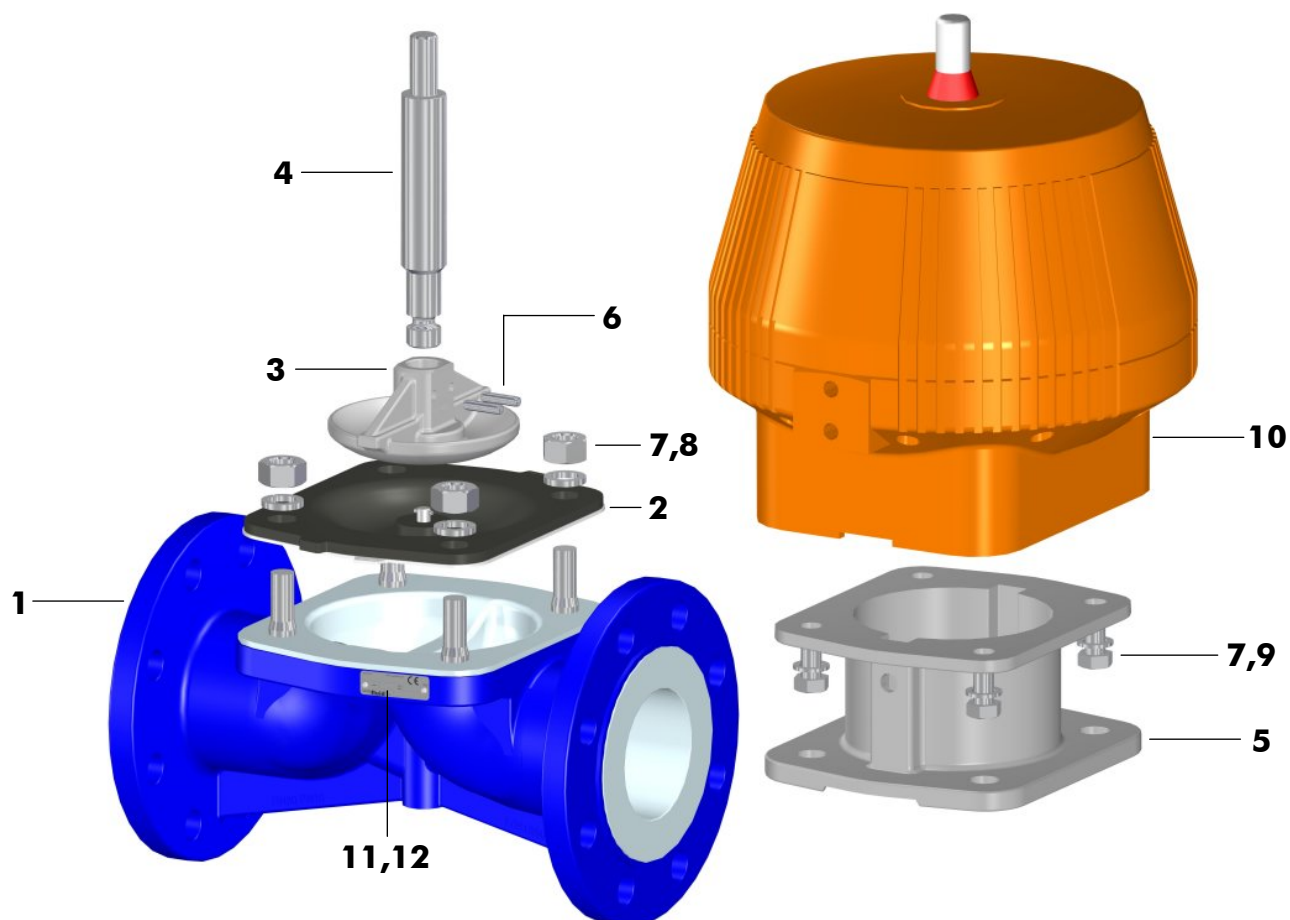

Item	Qty.	Description	Material	No.
1	1	Body PFA-lined, RAL 5005	WCB	1.0619
2	1	Diaphragm complete	PTFE/EPDM	
3	1	Compressor Plug Bayonet	CF-8M	1.4408
4	1	Actuator Spindle	A2	1.4305
5	1	Bracket	CF-8M	1.4408
6	2	Spring Tension Pin	A2	1.4310
7	8	Lock Washer	A2	1.4310
8	4	Hex. Nut	A2-70	1.4310
9	4	Hex. Head Screw	A2-70	1.4310
10	1	Pneumatic Linear Stroke Actuator	PP	SPA-L
11	1	Name Plate 42 x 14 CE	A2	1.4301
12	2	Hammer Screw 2.49 x 4.76	A2	1.4310





**Standard Version** (Picture showing DN 80 PN16, PFA-lined, with sliding spindle)

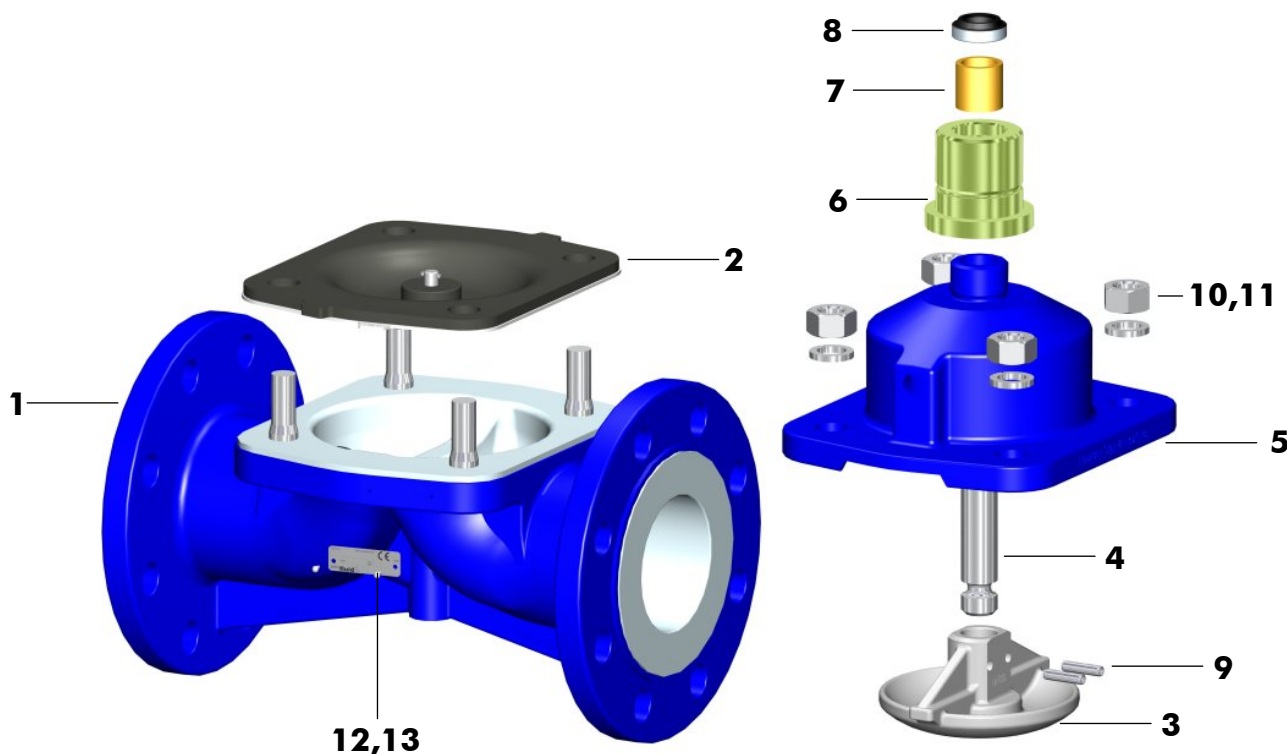

Item	Qty.	Description	Material	No.
1	1	Body PFA-lined, RAL 5005	WCB	1.0619
2	1	Diaphragm complete	PTFE/EPDM	
3	1	Compressor Plug Bayonet	CF-8M	1.4408
4	1	Sliding Spindle	A2	1.4305
5	1	Bonnet, RAL 5005	WCB	1.0619
6	1	Threaded Bushing	C.St/galv.	1.0737
7	1	Bushing	Bronze	
8	1	Scraper	St/Nitrile	
9	2	Spring Tension Pin	A2	1.4310
10	4	Lock Washer	A2	1.4310
11	4	Hex. Nut	A2-70	1.4310
12	1	Name Plate 42 x 14 CE	A2	1.4301
13	2	Hammer Screw 2.49 x 4.76	A2	1.4310

# SDV: Specification

21 Diaphragm Valves, plastomer-lined

PM 21 M.10 e

March 2006



Project-/Customer Data		Inquiry/Date:	Ref. Swissfluid
Company:		Contact Person:	Phone:
Address:		Function:	Fax:
ZIP/Place:		Department:	E-mail:
Project:		Phone direct:	Mobile:

## Operating Conditions

### Media / Chemical Composition:

<input type="checkbox"/> liquid	<input type="checkbox"/> powdery	<input type="checkbox"/> crystallizing	<input type="checkbox"/> sticky	<input type="checkbox"/> Spec. Grav. ____
<input type="checkbox"/> gaseous	<input type="checkbox"/> Solids ____ %	<input type="checkbox"/> viscous	<input type="checkbox"/> Flow Velocity ____ m/s	
<input type="checkbox"/> abrasive	<input type="checkbox"/> Particle ____ mm	<input type="checkbox"/> Visc. ____ cp	<input type="checkbox"/> Flow Rate ____ m <sup>3</sup> /hr	

### Pressure

max. \_\_\_\_ bar  
min. \_\_\_\_ bar

### Temperature

max. \_\_\_\_ °C  
min. \_\_\_\_ °C

### Mode

On/Off  
 Flow Control  
\_\_\_\_ cycles/ \_\_\_\_

### Installation / Environment

horizontal  Room dry  
 vertical  Room humid  
 outdoor

Remarks:

## Specification of a complete Diaphragm Valve SDV Series

