





# TABLE OF CONTENTS

<b>1. INTRODUCTION .....</b>	<b>1</b>
1.1 INTRODUCTION .....	1
1.2 REQUIRED USER-SUPPLIED HARDWARE .....	1
1.3 UPGRADING FROM THE IQ DATA PLUS II .....	2
1.4 REPLACEMENT PARTS .....	2
<b>2. HARDWARE DESCRIPTION .....</b>	<b>3</b>
2.1 INTRODUCTION .....	3
2.1.1 Operator Panel .....	3
2.1.2 Rear Access Area .....	3
2.1.3 User-Supplied External Hardware .....	5
2.1.4 Optional Communications Module .....	5
2.2 SPECIFICATIONS .....	5
2.2.1 General Specifications .....	5
2.2.2 Protective Function Specifications .....	6
2.2.3 Metering Specifications .....	7
<b>3. OPERATOR PANEL .....</b>	<b>8</b>
3.1 INTRODUCTION .....	8
3.1.1 Pushbuttons .....	8
3.1.2 Display Window .....	9
3.1.3 LEDs .....	9
<b>4. INSTALLATION AND STARTUP .....</b>	<b>12</b>
4.1 INTRODUCTION .....	12
4.2 PANEL PREPARATION AND MOUNTING THE IQ DP-4000 .....	12
4.2.1 Cutout, Clearances .....	12
4.2.2 Mounting .....	12
4.3 MOUNTING THE POWER SUPPLY MODULE SEPARATELY .....	13
4.4 WIRING .....	13
4.5 INITIAL STARTUP .....	20
4.5.1 During Initial Power Application .....	20
<b>5. PROGRAMMING THE IQ DP-4000 .....</b>	<b>21</b>
5.1 INTRODUCTION .....	21
5.2 SETTING SETPOINT SWITCHES .....	22
5.2.1 Setpoint Switch Programming Example .....	23
5.3 SYSTEM CONFIGURATION SETPOINT .....	23
5.4 FREQUENCY SELECTION SETPOINT .....	23
5.5 NOMINAL AC LINE VOLTAGE SETPOINT .....	23
5.6 VOLTAGE TRANSFORMER RATIO SETPOINT .....	24
5.7 CURRENT TRANSFORMER PRIMARY SETPOINT .....	24
5.8 PHASE SEQUENCE SETPOINT .....	24
5.9 DEMAND SETPOINTS .....	24
5.9.1 Power Demand, Fixed/Sliding .....	25
5.9.2 Power Demand Time Interval .....	25
5.9.3 Current Demand Time Interval .....	25
5.10 ENERGY SETPOINTS .....	25
5.10.1 Reset Energy From Faceplate Setpoint .....	25
5.10.2 Energy Resolution Setpoint .....	25
5.11 VAR/POWER FACTOR SIGN CONVENTION SETPOINT .....	26
5.12 ALARM FUNCTIONS - GENERAL .....	26
5.12.1 Relay Modes Alarm Setpoint .....	26

5.12.2	Latched/Unlatched (Auto-reset) Alarm Setpoint.....	27
5.12.3	Activate on Overvoltage Alarm Setpoint .....	27
5.12.4	Activate on Undervoltage Alarm Setpoint .....	27
5.12.5	Activate on Voltage Phase Loss Alarm Setpoint.....	27
5.12.6	Activate on Voltage Phase Unbalance Alarm Setpoint .....	27
5.12.7	Activate on Voltage Phase Reversal Alarm Setpoint .....	28
5.12.8	Activate on Current Phase Loss Alarm Setpoint.....	28
5.12.9	Enable/Disable Alarm Setpoint .....	28
5.12.10	Alarm Delay Setpoint .....	28
5.12.11	Alarm Reset Delay Setpoint .....	28
5.12.12	Overvoltage Detection Level Alarm Setpoint .....	29
5.12.13	Undervoltage Detection Level Alarm Setpoint .....	29
5.12.14	Voltage Phase Unbalance Detection Level Alarm Setpoint .....	29
5.12.15	Alarm Reset Threshold Setpoint .....	29
5.13	POWERNET PROGRAMMABLE SETPOINT .....	34
5.14	DP-4000 / DP-2 MODE SETPOINT.....	34
5.15	OPTIONAL I/O SETPOINTS.....	34
5.15.1	Discrete Input Setup Setpoint.....	34
5.15.2	Sync Pulse Setpoint.....	34
5.15.3	Pulse Initiator/Shed Load Setpoint.....	34

## 6. TROUBLESHOOTING AND MAINTENANCE

6.1	LEVEL OF REPAIR .....	39
6.2	MAINTENANCE AND CARE.....	39
6.3	TROUBLESHOOTING .....	39
6.4	REPLACEMENT .....	39
6.5	TECHNICAL ASSISTANCE .....	40
6.6	RETURN PROCEDURE.....	42

## LIST OF TABLES

TABLE 1.A	MODEL COMPARISON.....	1
TABLE 1.B	PARTS AND ACCESSORIES .....	2
TABLE 2.A	GENERAL SPECIFICATIONS.....	6
TABLE 2.B	PROTECTION FUNCTION (TRIP) SPECIFICATIONS .....	6
TABLE 2.C	METERING SPECIFICATIONS.....	7
TABLE 3.A	ALARM CODES .....	11
TABLE 5.A	SETPOINT MASTER SHEET .....	21
TABLE 5.B	GENERAL SYSTEM FUNCTIONS .....	22
TABLE 5.C	ALARM FUNCTIONS .....	22
TABLE 5.D	OPTIONAL I/O FUNCTIONS .....	22
TABLE 5.E	SETPOINT SWITCH SETTINGS.....	23
TABLE 5.F	AC LINE VOLTAGE .....	24
TABLE 5.G	POWER DEMAND INTERVALS FOR WATTS, VARS AND VA.....	25
TABLE 5.H	DEMAND SAMPLING INTERVAL FOR IA, IB, AND IC.....	25
TABLE 5.I	ALARM RELAY MODE SETTING.....	26
TABLE 5.J	LATCHED/UNLATCHED SETTINGS .....	27
TABLE 5.K	ACTIVATE ON OVERVOLTAGE SETTINGS.....	27
TABLE 5.L	ACTIVATE ON UNDERVOLTAGE SETTINGS.....	27
TABLE 5.M	ACTIVATE ON VOLTAGE PHASE LOSS SETTINGS .....	27
TABLE 5.N	ACTIVATE ON VOLTAGE PHASE UNBALANCE SETTINGS .....	27
TABLE 5.O	ACTIVATE ON VOLTAGE PHASE REVERSAL SETTINGS .....	28
TABLE 5.P	ACTIVATE ON CURRENT PHASE LOSS SETTINGS .....	28
TABLE 5.Q	ENABLE/DISABLE ALARM SETTINGS.....	28
TABLE 5.R	ALARM DELAY SETTINGS .....	28
TABLE 5.S	RESET DELAY SETTINGS .....	28
TABLE 5.T	OVERVOLTAGE DETECTION LEVEL SETTINGS .....	29
TABLE 5.U	UNDERVOLTAGE DETECTION LEVEL SETTINGS.....	29
TABLE 5.V	VOLTAGE PHASE UNBALANCE DETECTION LEVEL SETTINGS .....	29
TABLE 5.W	RESET THRESHOLD SETTINGS .....	30
TABLE 5.X	PULSE INITIATOR PARAMETER SELECTION SETTINGS.....	35
TABLE 5.Y	LOAD SHED AND RESTORE LOAD SETTINGS .....	36
TABLE 5.Z	LOAD SHED PARAMETER SELECTION SETTINGS.....	38
TABLE 5.AA	PULSE INITIATOR RATE SELECTION SETTINGS.....	38
TABLE 6.A	INITIAL POWER-ON TROUBLESHOOTING .....	40
TABLE 6.B	OPERATIONAL TROUBLESHOOTING .....	41

## LIST OF FIGURES

FIGURE 2.1	THREE PHASE POWER MODULE FOR MODELS 4030 AND 4130.....	3
FIGURE 2.2	REAR ACCESS AREA OF CHASSIS .....	4
FIGURE 3.1	OPERATOR PANEL .....	8
FIGURE 3.2	POWER QUADRANTS, MATHEMATICAL .....	10
FIGURE 3.3	POWER QUADRANTS, POWER ENGINEER'S SIGN CONVENTION.....	10
FIGURE 3.4	INDUCTION MOTOR LOAD .....	11
FIGURE 3.5	POWER DISTRIBUTION .....	11
FIGURE 4.1	CHASSIS CUTOOUT DIMENSIONS.....	12
FIGURE 4.2	SIDE PROFILE DEPTH DIMENSIONS .....	13
FIGURE 4.3	POWER MODULE DIMENSIONS .....	13
FIGURE 4.4	3-PHASE, 3-WIRE (UP TO 600 VOLTS) WIRING DIAGRAM.....	14
FIGURE 4.5	3-PHASE, 3-WIRE (ABOVE 600 VOLTS) WIRING DIAGRAM .....	15
FIGURE 4.6	3-PHASE, 3-WIRE (UP TO 600 VOLTS) WIRING DIAGRAM.....	15
FIGURE 4.7	3-PHASE, 3-WIRE (ABOVE 600 VOLTS) WIRING DIAGRAM .....	16
FIGURE 4.8	3-PHASE, 4-WIRE (UP TO 600 VOLTS) WIRING DIAGRAM.....	16
FIGURE 4.9	3-PHASE, 4-WIRE (ABOVE 600 VOLTS) WIRING DIAGRAM .....	17
FIGURE 4.10	3-PHASE, 3-WIRE (UP TO 600 VOLTS) WIRING DIAGRAM.....	17
FIGURE 4.11	3-PHASE, 3-WIRE (ABOVE 600 VOLTS) WIRING DIAGRAM .....	18

FIGURE 4.12	3-PHASE, 3-WIRE (UP TO 600 VOLTS) WIRING DIAGRAM.....	18
FIGURE 4.13	3-PHASE, 3-WIRE (ABOVE 600 VOLTS) WIRING DIAGRAM .....	19
FIGURE 4.14	3-PHASE, 4-WIRE ( UP TO 600 VOLTS) WIRING DIAGRAM.....	19
FIGURE 4.15	3-PHASE, 4-WIRE (ABOVE 600 VOLTS) WIRING DIAGRAM .....	20
FIGURE 5.1	OVERVOLTAGE DETECTION AND RESET LEVELS .....	31
FIGURE 5.2	UNDERVOLTAGE DETECTION AND RESET LEVELS .....	32
FIGURE 5.3	VOLTAGE PHASE UNBALANCE DETECTION/RESET LEVELS .....	33
<b>APPENDIX A - PT RATIO AND CT PRIMARY SETTINGS .....</b>		<b>43</b>
	PT RATIO SETTINGS .....	43
	CT PRIMARY SETTINGS.....	57
<b>APPENDIX B - SETPOINT RECORD SHEETS.....</b>		<b>71</b>

## USING THE MANUAL

This manual covers the installation, setup, operation, maintenance, and troubleshooting of the IQ DP-4000. It gives step-by-step instructions for programming the IQ DP-4000 to meet your specific application requirements.

If you are installing the IQ DP-4000 for the first time, you should read and become familiar with the following sections of the manual:

1. Introduction
2. Hardware Description
3. Operator Panel
4. Installation and Startup
5. Programming the IQ DP-4000
6. Maintenance and Troubleshooting Maintenance

If you are replacing an IQ Data Plus II with an IQ DP-4000, you should read and become familiar with the following sections of the manual:

1. Introduction, Section 1.3, Upgrading From the IQ Data Plus II
2. Troubleshooting and Maintenance, Section 6.3. The instructions for removing and replacing the IQ Data Plus II are the same as for removing and replacing the IQ DP-4000.

---

---

# SAFETY PRECAUTIONS AND LIABILITY INFORMATION

## PRELIMINARY COMMENTS AND SAFETY PRECAUTIONS

This Technical Document covers all aspects of installation, operation, and unit-level maintenance of the IQ DP-4000. This document is a guide only for authorized and qualified personnel who select and use the IQ DP-4000. Please refer to the specific Warning and Caution in this section before proceeding. If you require further information regarding a particular installation, application, or maintenance activity, contact your Cutler-Hammer Representative.

### Warranty and Liability Information

No warranties, expressed or implied, including warranties of fitness for a particular purpose of merchantability, or warranties arising from course of dealing or usage of trade are made regarding this information, recommendations, and descriptions contained herein. In no event will Cutler-Hammer be responsible to the purchaser or user in contract, in tort (including negligence), strict liability, or otherwise for any special, indirect, incidental, or consequential damage or loss whatsoever, including but not limited to damage or loss of use of equipment plant or power system, cost of capital, loss of power, additional expenses in the use of existing power facilities, or claims against the purchaser or user by its customers resulting from the use of the information and descriptions contained herein.

### Safety Precaution

All safety codes, safety standards, and/or regulations must be strictly observed in the installation, operation, and maintenance of this device.

---

 **WARNING**

---

**THE WARNINGS AND CAUTIONS INCLUDED AS PART OF THE PROCEDURAL STEPS IN THIS DOCUMENT ARE FOR PERSONNEL SAFETY AND PROTECTION OF EQUIPMENT FROM DAMAGE. AN EXAMPLE OF A TYPICAL WARNING LABEL IS SHOWN ABOVE IN REVERSE TYPE TO FAMILIARIZE PERSONNEL WITH THE STYLE OF PRESENTATION. THIS WILL HELP TO ENSURE THAT PERSONNEL ARE ALERT TO WARNINGS WHICH MAY APPEAR THROUGHOUT THE DOCUMENT. IN ADDITION, CAUTIONS ARE ALL UPPER CASE AND BOLDFACED AS SHOWN BELOW.**

---

 **CAUTION**

---

**COMPLETELY READ AND UNDERSTAND THE MATERIAL PRESENTED IN THIS DOCUMENT BEFORE ATTEMPTING TO INSTALL, OPERATE OR USE THE EQUIPMENT. IN ADDITION, ONLY QUALIFIED PERSONS SHOULD BE PERMITTED TO PERFORM ANY WORK ASSOCIATED WITH THE EQUIPMENT. ANY WIRING INSTRUCTIONS PRESENTED IN THIS DOCUMENT MUST BE FOLLOWED PRECISELY. FAILURE TO DO SO COULD CAUSE PERMANENT EQUIPMENT DAMAGE.**

### Factory Correspondence

Contact the Power Management Applications Support (PMAS) at 1-800-809-2772 if you have any questions about operating or troubleshooting the IQ DP-4000.

*<http://www.ch.cutler-hammer.eaton.com/pmp>*



**1.1 INTRODUCTION**

The IQ DP-4000 is a microprocessor-based monitoring and protective device that provides electrical metering and system voltage protection. This device is a compact, self-contained, panel-mounted device designed to replace numerous individual meters, relays, and recorders. The IQ DP-4000 is available in six models - 4010, 4020, 4030, 4110, 4120 and 4130. Table 1.A compares the models' features.

Model	Power Module	I/O
4010	Separate Source	No
4020	24-48Vdc source	No
4030	3-Phase	No
4110	Separate Source	Yes
4120	24-48Vdc source	Yes
4130	3-Phase	Yes

**Table 1.A Model Comparison**

The IQ DP-4000 measures:

- AC Line Current (each phase)
- AC Line to Line Voltage
- AC Line to Neutral Voltages (for 4 wire systems)
- Watts
- Vars
- VA
- Power Factor (apparent and displacement)
- Demand (Watts, Vars, VA, Currents)
- Frequency
- %THD (currents and voltages)
- Watt-hours
- Var-hours
- VA-hours

The IQ DP-4000 monitors the ac line feeding a specific load or loads and detects conditions that exceed your chosen parameters. In all cases, it detects the following listed conditions. If equipped with the optional I/O module (models 4110, 4120, and 4130), it can protect the loads against:

- Undervoltage
- Overvoltage
- Current Phase Loss
- Voltage Phase Loss
- Phase Reversal
- Phase Unbalance

Voltage may be directly monitored on 3-phase AC lines within a range of 100 to 600 VAC nominal without external potential transformers and within a range above 600VAC to 510 KV with external potential transformers (PTs). Current monitoring is through external current transformers (CTs) with ratios between 5/5 to 12,800/5.

Typical applications for the IQ DP-4000 are:

- Incoming 3-Phase AC lines
- Transformer feeder circuits
- Branch circuits
- Motor starters
- 3-Phase electrical loads

Based upon transformer ratios, the device will automatically display the appropriate unit value (in Units, Kilo-Units, or Mega-Units) of the item displayed on the screen. The values have a floating decimal point.

The program directing the monitoring function is permanently stored in the IQ DP-4000. The setpoints you choose are also retained by the non-volatile EEPROM memory.

The non-volatile memory of the IQ DP-4000 will save a snapshot of all metered values just after an alarm condition. The IQ DP-4000 can store two alarm conditions at the same time. You can view the snapshot for each alarm and record the values before or after resetting the unit.

The operator panel, the unit's front faceplate, has a display window that indicates the actual value of the selected item. The Display Window also indicates the cause of the detected alarm signal.

You choose and enter the individual setpoints by setting the setpoint switches, so you do not need a specialized programming language. A Configuration Disk is included with each DP-4000. This disk contains a Windows-95/3.XX tool that assists you with the proper switch settings; however, it does not download settings to the meter.

**1.2 REQUIRED USER-SUPPLIED HARDWARE**

In all instances, it is recommended that the IQ DP-4000 use three user-supplied external current transformers, with 5 amp secondaries, for metering current functions. In retrofit cases, where only two current transformers are provided, refer to the sample wiring diagrams (Figures 4.4 - 4.15).

*Note: A 2 CT arrangement will work, but will not detect a current phase loss on L2.*

For voltages above 600V, you must supply potential transformers to step down the voltage to match the maximum allowable voltage permitted by the unit. See Table 5.F (p.24) for the voltage ranges that the IQ DP-4000 monitors.

For backward compatibility with existing IMPACC systems, the IQ DP-4000 features an IQ Data Plus II communications mode that formats all buffers as if the product were a Data Plus II. This is the default communications mode when the unit is manufactured. See Section 5.14 (p.34) to change this setpoint.

**1.3 UPGRADING FROM THE IQ DATA PLUS II**

The IQ DP-4000 replaces the IQ Data Plus II (DP II). The IQ DP-4000 features all the monitor and display parameters of the DP II and also adds:

- Metering of VA, Var-hours, VA-hours, and %THD
- Optional I/O module
- Min/Max for voltages, current, and power
- Demand/Peak Demand
- Max % THD (currents and voltages)
- Metering parameters with an active alarm condition present
- Expanded PowerNet / IMPACC functionality
- Increased range and resolution for metered parameters

**⚠ CAUTION**

**FOR FULL BACKWARD COMPATIBILITY, ALL SETPOINTS MUST CORRESPOND WITH AN EXISTING VALID DP II SETPOINT. SEE TD 17271 FOR DATA PLUS II SETTINGS. THE WIRING IS IDENTICAL WITH THE EXCEPTION OF THE SEPARATE SOURCE POWER MODULE TERMINALS. NOTE THAT NO JUMPERS ARE REQUIRED FOR 120/240 VOLT SELECTION.**

**1.4 REPLACEMENT PARTS**

Refer to Table 1.B for a list of available parts and accessories for the IQ DP-4000. For ordering information, contact your local Cutler-Hammer distributor.

Description	Catalog Number
IQ DP-4000 with 100-240V separate source power module without I/O module	IQDP4010
IQ DP-4000 with 24 - 48Vdc power module without I/O module	IQDP4020
IQ DP-4000 with 100-600Vac 3-phase power module without I/O module	IQDP4030
IQ DP-4000 with 100-240V separate source power module with I/O module	IQDP4110
IQ DP-4000 with 24-48Vdc power module with I/O module	IQDP4120
IQ DP-4000 with 100-600Vac 3-phase power module with I/O module	IQDP4130
3-phase power module (100-600Vac)	IQM3PPM
Separate source power module (100-240Vac, 100-250Vdc)	IQMSSPM
24 - 48Vdc power module	IQMDCPM
36" extension cable	IQACABLE
45" extension cable	IQA45CABLE
IQ mounting flange	IQFLANGE
Communication modules: INCOM Product Operated Network Interface Ethernet Product Operated Network Interface (10Base-T only) Ethernet Product Operated Network Interface (10Base-T & 10Base-FL)	IPONI EPONI EPONIF
IQ DP-4000 Auxiliary Power Supply	IQDPAUXPS
IQ DP-4000 Configuration Utility (setpoint programming aid, included with DP-4000)	See the Cutler-Hammer website at <a href="http://www.ch.cutler-hammer.eaton.com/pmp">http://www.ch.cutler-hammer.eaton.com/pmp</a>

**Table 1.B Parts and Accessories**

**ORDERING NOTE:**

**IQA3PPM and IQASSPM are no longer compatible with the DP-4000 (66D2040). Order IQM3PPM, IQMSSPM, or IQMDCPM. The IQA3PPM and IQASSPM modules are replacements for use on the previous DP-4000 (4D13110).**

**2.1 INTRODUCTION**

The IQ DP-4000 is designed for mounting through a cutout in a panel (usually a cabinet face or door). The hardware description is divided into the following:

- Operator Panel
- Rear Access Area
- User-Supplied External Hardware
- Optional Communications Module

**2.1.1 Operator Panel**

The operator panel, the front face of the IQ DP-4000, is accessible from the outside of the panel or door into which it is mounted and allows you to:

- Monitor the actual metered values on the display window
- Determine which metered value is being displayed
- Step through the list of metered items
- Determine that an alarm condition exists
- Determine the cause of the alarm condition
- Reset the unit after an alarm condition
- View and reset minimum and maximum values from the faceplate
- Reset energy

See Section 3 for a detailed description of the operator panel.

**2.1.2 Rear Access Area**

You can access the rear of the IQ DP-4000 by opening the door onto which it is mounted. Make all wiring connections to the unit from the rear of the chassis. Figure 2.2 shows the rear of the chassis and includes:

1. The 3-Phase AC line connections to the voltage terminal block at the bottom of the power module.
2. The current transformer terminal block at the top of the chassis connects to the required external current transformers.
3. The Alarm 1/Alarm 2 terminal block connects to controlled, external devices (with the optional I/O module only).

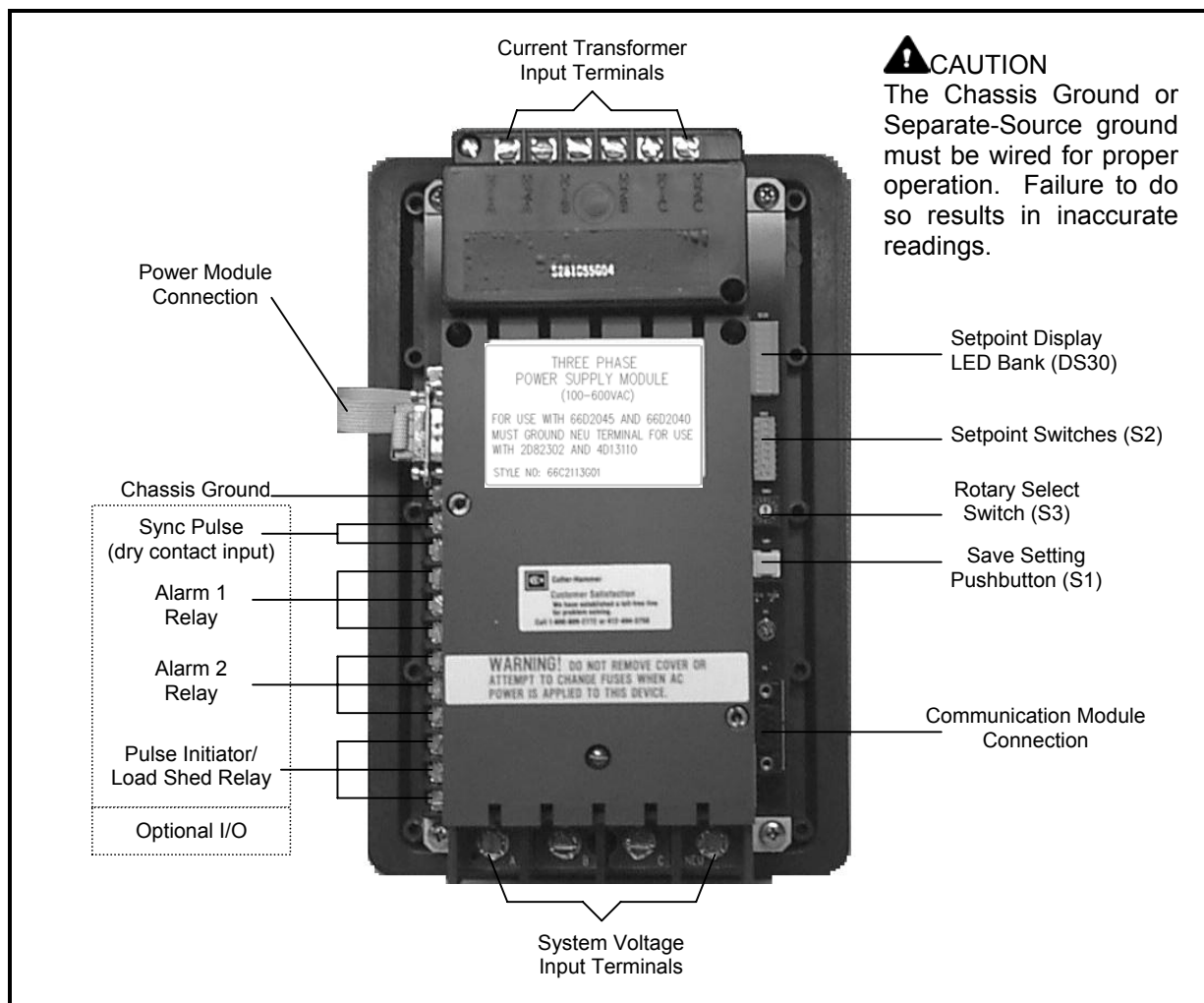
4. Setpoint Switches, located on the rear right side of the chassis, allow you to tailor each IQ DP-4000 model for your specific applications. For a complete description of each Setpoint Switch setting see Section 5.
5. The power module is available as a separate source power module (Models 4010, 4110), as a 3-Phase power module (Models 4030, 4130), and as a dc power module (Models 4020, 4120).

The Power Module for the IQ DP-4000 is mounted on the rear of the chassis when shipped, but can be detached and moved up to 45 inches (91cm) away using an optional ribbon cable (Cat. No. IQA45CABLE) if local codes prevent AC power devices from being located on the cabinet door.



**Figure 2.1 The Three-Phase Power Module for Models 4030 and 4130**

*Note: The Separate source power supply can be powered by 100-240VAC or 100-250VDC ± 10%.*



**Figure 2.2 Rear Access Area of Chassis**

**! WARNING**

**REMOVE ALL VOLTAGE FROM THE IQ DP-4000 BEFORE REMOVING AND/OR REPLACING FUSES.**

6. A fuse, internal to the three-phase power module, is located in series with each of the 3 incoming AC lines. The fuses are 3/4 amp, 600 volt, 200kA interrupting rating. These fuses are internal to the power module. You can access them by removing the three screws holding the cover in place (see Figures 2.1 and 2.2).

**Required:** The voltage terminal block has four terminals for wiring (one is neutral). The neutral must be connected to Neutral or Ground depending on your configuration.

7. The communication port, located on the lower right chassis, is designed to connect with the optional communication module (a PONI module). See Section 2.1.4 for a detailed description.
8. The discrete input can be configured to be either a reset input or a sync pulse input. The input is activated by a contact closure across terminal block contacts 1 and 2. See Section 5.15.1 (p.34) for configuring this input.
9. Watt-hour Pulse. The Watt-hour pulse initiator is a set of contacts that completes a circuit and sends a

pulse signal to an external pulse recorder. You can program the amount of energy between pulses using Setpoint Switches (see Section 5.15.3 p.34). The pulse initiator is a KYZ output, meaning the relay will change state for each pulse.

### 2.1.3 User-Supplied External Hardware

The IQ DP-4000 requires you to wire at least 2, and up to 3 current transformers into the CT terminal block from an external location (see Figures 4.4 - 4.15 pp.14-20). These are user-supplied and must have a 5 Amp secondary. Potential transformers are required only for voltages above 600 V and are wired directly to the AC line connection terminals.

### 2.1.4 Optional Communication Module

The IQ DP-4000 is a PowerNet compatible device. PowerNet can remotely monitor, control, and program the IQ DP-4000.

Communications is made possible by attaching a communications module (IPONI, EPONI, or EPONIF). Since the DP-4000 is always supplied with a communications port, any PONI (Product Operated Network Interface) can be easily retrofitted at any time. The PONI modules may be connected to or disconnected from the DP-4000 under power without risk of damage to either product.

#### 2.1.4.1 IPONI

The IPONI (INCOM Product Operated Network Interface) is a small, addressable communication module that attaches to the back of the DP-4000. The module can be mounted directly to the back of the DP-4000 or to a Power Module that is already mounted on the DP-4000. Addresses and BAUD Rates are established on the IPONI itself. Refer to the instruction details supplied with the IPONI for details.

#### 2.1.4.2 EPONI and EPONIF

The EPONI is an Ethernet Product Operated Network Interface that attaches directly to the back of the DP-4000. The power module can then be mounted to the PONI or mounted remotely (36 inches away). The EPONIF is an Ethernet PONI with a 10Base-FL (fiber-optic) interface. Refer to the instruction details supplied with the IPONI for details.

#### 2.1.4.3 PowerNet Software Suite

Regardless of the type of PONI chosen, PowerNet offers a two-tiered communication system that is based on an Ethernet backbone and an INCOM frequency carrier signal, running inside equipment rooms. The Ethernet backbone follows standard Ethernet wiring rules, allowing a mix of CAT5 cable and Fiber based networks. The INCOM signal may extend up to 10,000 feet and connect 200 devices through a NetLink to the Ethernet backbone.

The PowerNet Software Suite provides the ability to monitor and record power distribution system data as it occurs. PowerNet is a Microsoft™ Windows 95/98/NT compatible application featuring user-friendly, menu-driven screens.

#### 2.1.4.4 PowerNet Graphics

PowerNet Graphics software provides the capability to generate custom animated color graphics. For example, animated one-line drawings of electrical power distribution systems, flow diagrams of processes, equipment elevation view, and other graphical representations can be developed.

#### 2.1.4.5 Connectivity

A computer running the PowerNet Software Suite can interface with other networks. Examples of connectivity interfaces include:

- PLCs (Programmable Logic Controllers)
- DCSs (Distributed Control Systems)
- BMSs (Building Management Systems)
- PC-based graphical operator interface programs

## 2.2 SPECIFICATIONS

This section covers the following specifications:

- General Specifications (Table 2.A p.6)
- Protection Function Specifications (Table 2.B p.6)
- Metering specifications (Table 2.C p.7)

### 2.2.1 General Specifications

The IQ DP-4000 is intended for indoor use only, and meets the following specifications:

Function	Specifications
Power Requirement	PT Burden (3-Phase power module) 10VA PT Burden (separate source & dc power modules) 0.02 VA CT Burden 0.003 VA
Frequency	50/60 Hz
Line Characteristics / Transient Overvoltage Category	Three phase source: 100 – 600VAC ± 10% Category III  Separate source: 100 – 240VAC ± 10% 100 – 250Vdc ± 10% Category II  dc source: 24 – 48Vdc ± 20% Category I
Pollution Degree	2 (IEC664)
Altitude	3000m
Operating Temperature	-20° to 70°C (-4° to 158°F)
Storage Temperature	-30° to 85°C (-22° to 185°F)
Humidity	5 to 95% RH non-condensing
Fuses	3/4 ampere, 600 volts, Buss Type KTK-R-3/4 (3 required).
Alarm/WH Contact Ratings	10 amps @ 120/240 VAC (Resistive) 10 amps @ 30 VDC (Resistive)
Terminal Specs.	Wire Size: #14-22 AWG Screw Size: #6-32 Torque: 8-10 in.-lbs.
DP-4000 Dimensions	Overall Depth: 4.42 in. Overall Height: 10.25 in. Overall Width: 6.72 in.
DP-4000 Weight	3.7 pounds
Cleaning / Maintenance	Never clean or change fuses at the rear of the DP-4000 with power applied. Clean the rear with a clean dry cloth. Clean the face of the unit with a dry cloth or a damp cloth with water or a mild detergent.

**Table 2.A General Specifications**

**2.2.2 Protective Function Specifications**

You can individually select each of the protection functions to initiate an alarm on any, all, or no functions. A short description of each of the protection functions follows:

- Voltage phase loss. A Voltage phase loss is detected when the amplitude of any single phase is less than 50% of the nominal amplitude.
- Current phase loss. A Current phase loss is detected when the current amplitude of the smallest phase is 6.25% of the current amplitude of the largest phase.
- Phase Unbalance. A phase voltage unbalance is detected when the difference between the largest and smallest line-to-line voltages exceeds the percentage of nominal line voltage by a factor of 5, 10, 15, 20, 25, 30, 35, or 40%. (The Setpoint Switch position determines the % factor.)Phase Reversal. A phase reversal is detected if a phase sequence different from that which was programmed (ABC or CBA) is detected.
- Overvoltage. An overvoltage is detected when the amplitude of the AC line voltage exceeds 105, 110, 115, 120, 125, 130, 135, or 140% of the nominal line voltage. (The Setpoint Switches determine the % factor.)
- Undervoltage. An undervoltage is detected when the amplitude of the AC line voltage falls below 95, 90, 85, 80, 75, 70, 65, or 60% of the nominal line voltage. (The Setpoint Switches determine the % factor.)

All protected functions update every 1.4 seconds with a 60 Hz line, or every 1.5 seconds with a 50 Hz line.

Protection Function	Description
Voltage Phase Loss	Any phase less than 50% of nominal
Current Phase Loss	Smallest phase less than 6.25% of largest phase
Phase Unbalance	Line voltage ± nominal in ranges from 5 to 40%
Phase Reversal	3-Phase Sequence
Overvoltage	Range 105 to 140%
Undervoltage	Range 95 to 60%
Alarm Delay	Range 1 to 20 seconds
Reset Delay	Range 1 to 120 seconds

**Table 2.B Protection Function Specifications**

**2.2.3 Metering Specifications**

Table 2.C shows the metering specifications for the IQ DP-4000.

<b>Item</b>	<b>Displayed through PowerNet</b>	<b>Local Display</b>
AC Amperes Phases A, B, C	+/- 0.3%	+/- 0.3% +/- 1 digit
AC Voltage Phase A-B, B-C, C-A	+/- 0.3%	+/- 0.3% +/- 1 digit
Phase A-N, B-N, C-N	+/- 0.3%	+/- 0.3% +/- 1 digit
Watts	+/- 0.6%	+/- 0.6% +/- 1 digit
Vars	+/- 0.6%	+/- 0.6% +/- 1 digit
VA	+/- 0.6%	+/- 0.6% +/- 1 digit
Watt-hours	+/- 0.6%	+/- 0.6% +/- 1 digit
Var-hours	+/- 0.6%	+/- 0.6% +/- 1 digit
VA-hours	+/- 0.6%	+/- 0.6% +/- 1 digit
Power Factor	+/- 1 %	+/- 1 %
Frequency	+/- 0.1Hz	+/- 0.1 Hz
% THD	Through 31st Harmonic	

**Table 2.C Metering Specifications**

Accuracy is maintained from 10% to 250% of the full scale of the device.

Nominal Full Scale Current: 5 Amps ac

Nominal Full Scale Voltage: 120-600 Vac

**Certification**

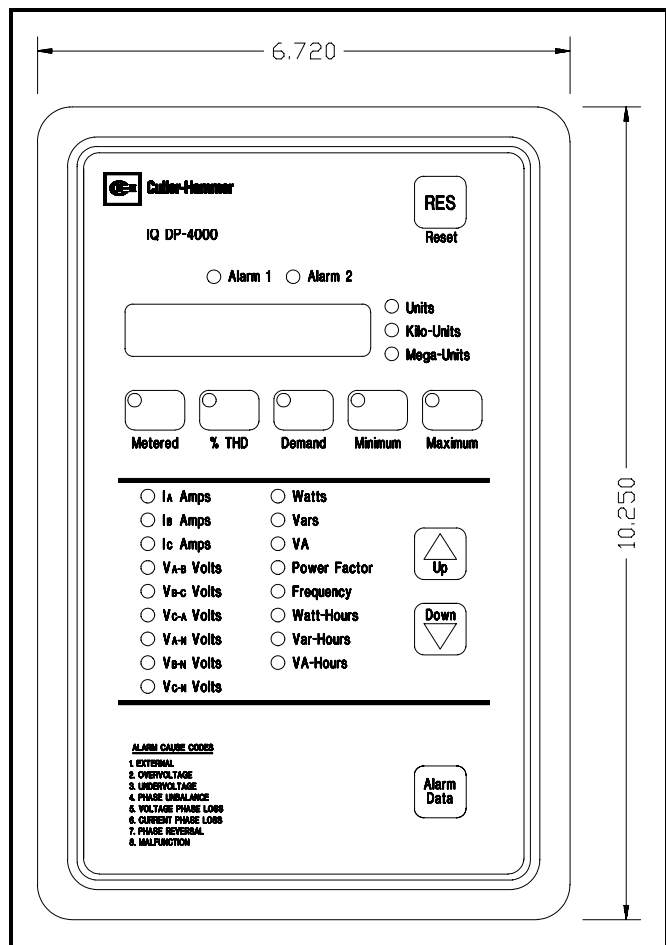
- UL / cUL: Listed UL-508, File E62791, NKCR Auxiliary Devices (with IQM3PPM)  
Listed UL-3111, File E185559, Metering (with IQMSSPM, IQMDCPM)
- NEMA: 3R, 12 (with supplied gasket)
- FCC: Part 15, Class A
- CISPR: CISPR-11 Class A
- CE: Units marked with CE comply with IEC 1010-1 (1990) incl. Amend 1&2 (1995)  
EN61010-1 (1993), CSA C22.2#1010.1 (1992), and EN50082-2 (1994)

**3.1 INTRODUCTION**

This section describes the operator panel of the IQ DP-4000. The discussion of the operator panel contains the following sections:

- pushbuttons
- display window
- LEDs

The operator panel is shown in Figure 3.1



**Figure 3.1 Operator Panel**

**3.1.1 Pushbuttons**

The operator panel has nine membrane pushbuttons. They are:

- **Reset.** After an alarm event, the Reset pushbutton allows you to reset the alarms. The Reset pushbutton is the red button marked RES, located in the upper right-hand corner of the faceplate.
- **Up/Down Step Display.** The Up/Down pushbuttons step through the items that the IQ DP-4000 monitors. If you press the Up and the Down buttons

at the same time, the INCOM network address for your unit appears in the Display Window. It monitors the following items:

- I<sub>A</sub> Amps
- I<sub>B</sub> Amps
- I<sub>C</sub> Amps
- V<sub>A-B</sub> Volts
- V<sub>B-C</sub> Volts
- V<sub>C-A</sub> Volts
- V<sub>A-N</sub> Volts
- V<sub>B-N</sub> Volts
- V<sub>C-N</sub> Volts
- Watts
- Vars
- VA
- Power Factor (apparent and displacement)
- Frequency
- Watt-Hours
- Var-Hours
- VA-Hours

Each time you press the Up or Down pushbuttons, the LED to the left of the selected item illuminates. At the same time, the present operating value corresponding to that item is in the display window.

- **Alarm Data pushbutton.** The Alarm Data pushbutton, located on the bottom right of the operator panel, allows you to toggle between Alarm 1, Alarm 2, and presently metered values. A blinking LED indicates you are viewing the snapshot (data saved at the time an alarm condition occurred for that particular alarm. An LED that is constantly illuminated indicates an active alarm condition for that particular alarm. (Please note that the Alarm LED will always blink when being viewed, even for an active alarm).

If you press the Alarm Data button before there has been an alarm condition, no light appears beside the Alarm.

- **Monitor pushbuttons.** The Monitor pushbuttons, located in a row just below the LED display window are:



- Metered. The Metered pushbutton displays the metered values for all the parameters on the Operator Panel.
- %THD. This button displays Percent Total Harmonic Distortion for the amps and volts for each phase.
- Demand. The Demand button displays the demand current for each phase, as well as the demand Watts, Vars, and VA.
- Minimum. This button displays the minimum values for all currents and voltages as well as Watts, Vars, VA, Power Factor (apparent and displacement) and Frequency. You can view and reset this value from the faceplate.
- Maximum. This button displays the maximum values for all currents and voltages as well as Watts, Vars, VA, Power Factor (apparent and displacement) and Frequency. You can view and reset this value from the faceplate.
- Stepup and Stepdown. Holding the Stepup and Stepdown pushbuttons will display the INCOM address (only if the PONI module is attached and communication has been established).
- Minimum and Maximum pushbuttons. Holding the Maximum and Minimum pushbuttons simultaneously will display the version of firmware the device is currently using. This is useful when troubleshooting the device.

*Note: The Metered, %THD, and Demand pushbuttons can work with the Minimum and Maximum pushbuttons to display minimum and maximum metered values, maximum % THD, and maximum peak demand.*

- Pushbutton combinations.
  - Reset and Metered. Holding the Reset and Metered pushbuttons simultaneously for three to four seconds will reset minimum and maximum values for all metered parameters. This will cause the display to blank, and the Metered LED to blink. When the display is restored, the Metered Min/Max values have been reset.
  - Reset and %THD. Holding the Reset and the %THD pushbuttons simultaneously for three to four seconds will reset maximum values for all %THD parameters. This will cause the display to blank, and the %THD LED to blink. When the display is restored, the Maximum %THD values have been reset.
  - Reset and Demand. Holding the Reset and the Demand pushbuttons simultaneously for three to four seconds will reset maximum values for all Demand parameters. This will cause the display to blank, and the Demand LED to blink. When the display is restored, the Maximum Demand values have been reset.

### 3.1.2 Display Window

The IQ DP-4000 has a large, easy to read 6-digit LED display window that shows the value for the associated Monitor pushbuttons, the values for the protective functions and the alarm cause codes. The display window is at the top of the faceplate, just below the Alarm LEDs.

### 3.1.3 LEDs

The Operator Panel LEDs are divided into four types:

- Monitor LEDs
- Parameter LEDs
- Units LEDs
- Alarm LEDs

#### 3.1.3.1 Monitor LEDs

At any given time, one or more of the LEDs associated with a Monitor pushbutton is illuminated. Each one identifies which monitor item is currently displayed. The Monitor LEDs are part of the Monitor pushbuttons and are labeled:

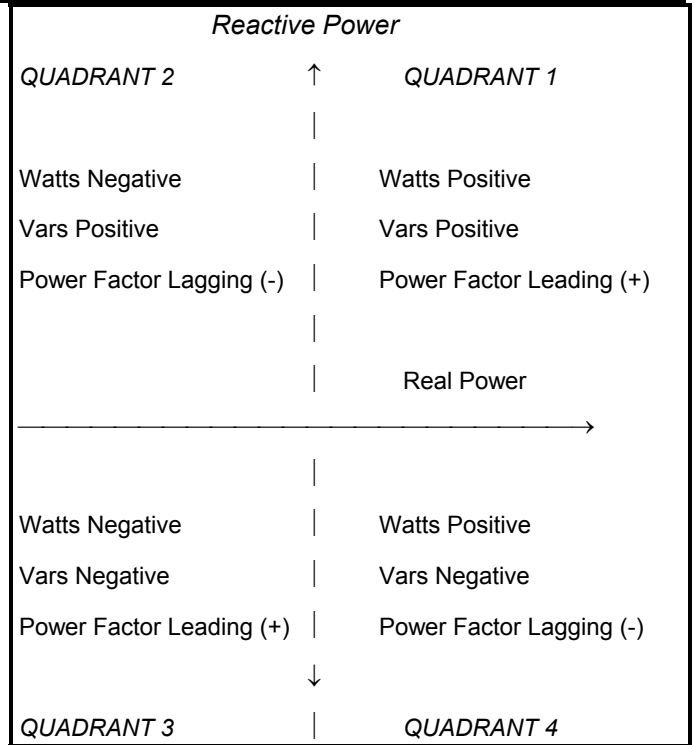
- Metered
- %THD
- Demand
- Minimum
- Maximum

#### 3.1.3.2 Parameter LED's:

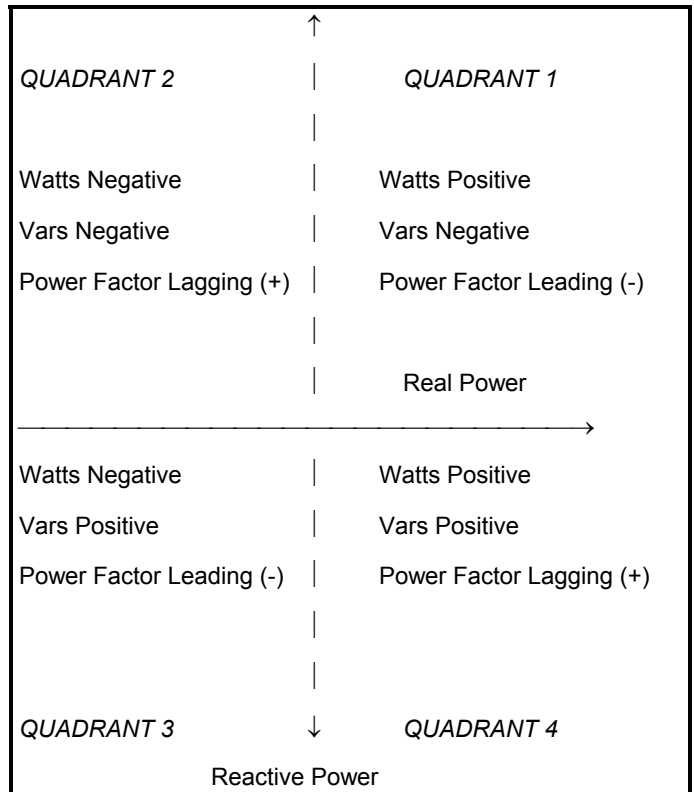
The LEDs that monitor the following conditions will blink in response to several monitoring situations:

*Note: The following examples assume that the unit is using the mathematic sign convention.*

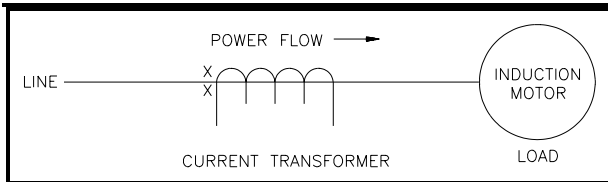
- Watts, Vars and/or Power Factor. The selected LEDs blink when viewing reverse power flow, lagging (negative) Power Factor, and negative Vars. The LEDs do not blink if the values are positive (leading). Refer to Figures 3.2, 3.3, 3.4 and 3.5 for further explanation.
- Induction Motor Loads. Typically when monitoring induction motor loads the power flow is in Quadrant 4. The Watts are positive and the Power Factor is lagging. By definition, the Power Factor and Vars are negative and the LEDs will blink for these two values. Refer to Figure 3.2.
- Power Factor Correction Capacitors. When monitoring a load that also has Power Factor correction capacitors and/or leading Power Factor synchronous motors so that the new load is capacitive, then the power flow is in Quadrant 1. In this case, none of the LED's will blink.
- Power Distribution. Typically you will encounter three conditions when monitoring power distribution (Refer to Figure 3.5 p.10):
  1. Breakers A and B are closed and C is open. Power flow is in Quadrant 4. The Power Factor and Vars will be negative and the respective LED's will blink.
  2. Breakers A and C are closed and B is open. Power flow for Breaker A and C is in Quadrant 4. The Power Factor and Vars will be negative, and the LED's will blink for Power Factor and Vars readings.
  3. Breakers B and C are closed and A is open. The power flow for Breaker B is in Quadrant 4 and the metering condition is the same as Conditions 1 and 2. However, the power flow for Breaker C is reversed and is in Quadrant 2. Only the Watts LED and Power Factor LED will blink.



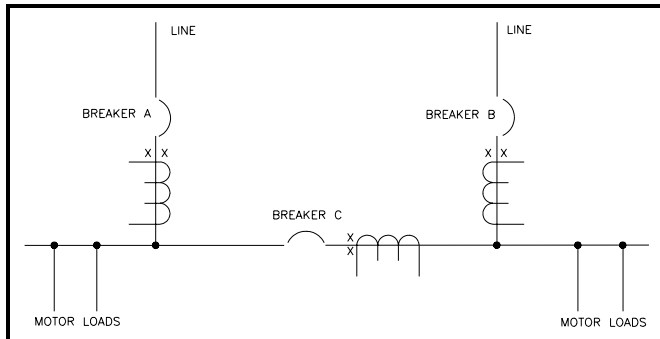
**Figure 3.2 Power Quadrants, Mathematical**



**Figure 3.3 Power Quadrants, Power Engineer's Sign Convention**



**Figure 3.4 Induction Motor Load**



**Figure 3.5 Power Distribution**

*Note: Refer to section 5.11(p.26) VAR/Power Factor Sign Convention Setpoint for more information about + and - values.*

Alarm Cause Code	Operator Panel Designation	Description
1	External	Remote device initiates alarm
2	Overvoltage	An alarm condition occurs
3	Undervoltage	
4	Phase Voltage Unbalance	
5	Voltage Phase Loss	
6	Current Phase Loss	
7	Phase Reversal	
8	Malfunction	Internal Data Out of Range  Cycle Power.

**Table 3.A Alarm Codes**

**3.1.3.3 Units LEDs: Auto Range Units for Monitoring**

The units for monitoring are Units, Kilo-Units, and Mega-Units. Figure 3.1 (p.8) shows the location of these LEDs to the right of the display window. These units are fixed, based on your selection for PT and CT ratios so that the display is consistent with the PT and CT sizes. They let you know the measurement unit for the displayed function.

**3.1.3.4 Alarm LED's**

The Alarm LEDs, (Alarm 1, Alarm 2) when continuously lit, indicate that an alarm condition exists. If there is an alarm condition when you press the Alarm Data button, the corresponding LED blinks and the display window shows a digit, from 1 to 8. This digit represents the specific type of alarm condition that is occurring for the selected alarm. The alarm cause codes are listed at the bottom of the faceplate for easy reference. Table 3.A describes the alarm codes by number.

**4.1 INTRODUCTION**

This section provides the information for installing the IQ DP-4000 into a metal cabinet door, and performing initial startup. Before beginning installation, be sure to read and understand both this section and Section 2, Hardware Description.

Installing the IQ DP-4000 includes four steps:

1. Mounting the IQ DP-4000
2. Mounting the power source separately from the IQ DP-4000 (if necessary)
3. Wiring the IQ DP-4000
4. Starting the unit for the first time



**DO NOT HIGH-POT OR MEGGER THIS DEVICE**

**4.2 PANEL PREPARATION AND MOUNTING**

The IQ DP-4000 is typically mounted on a metal cabinet door. To install the device you must:

- Cut an opening in the door
- Mount the unit

**4.2.1 Cutout, Clearances**

Before mounting the IQ DP-4000, you must prepare the cutout location. Figure 4.1 shows the chassis cutout dimensions and the location of the ten mounting holes. Before cutting the panel, be sure that the required 3-dimensional clearances for the IQ DP-4000 chassis allow mounting in the desired location (Figure 4.1 shows height and width dimensions, while Figure 4.2 shows depth dimensions.)

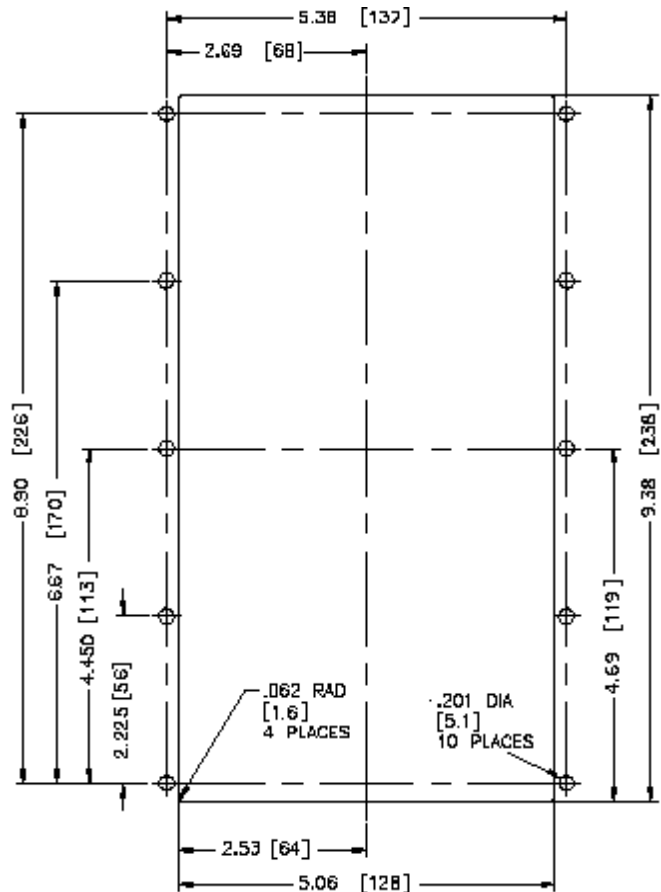
It is necessary to hold several tolerances when making the cutout and placing the holes for the mounting screws. Referring to Figure 4.1, the holes must be located within 1/16" of the drawing specifications, and a .201" to 7/32" drill bit is recommended. The height and width are less critical and have a 1/4" tolerance. In fact, the width of the cutout may extend to the center of the drilled holes if the holes are pre-drilled..

**4.2.2 Mounting**

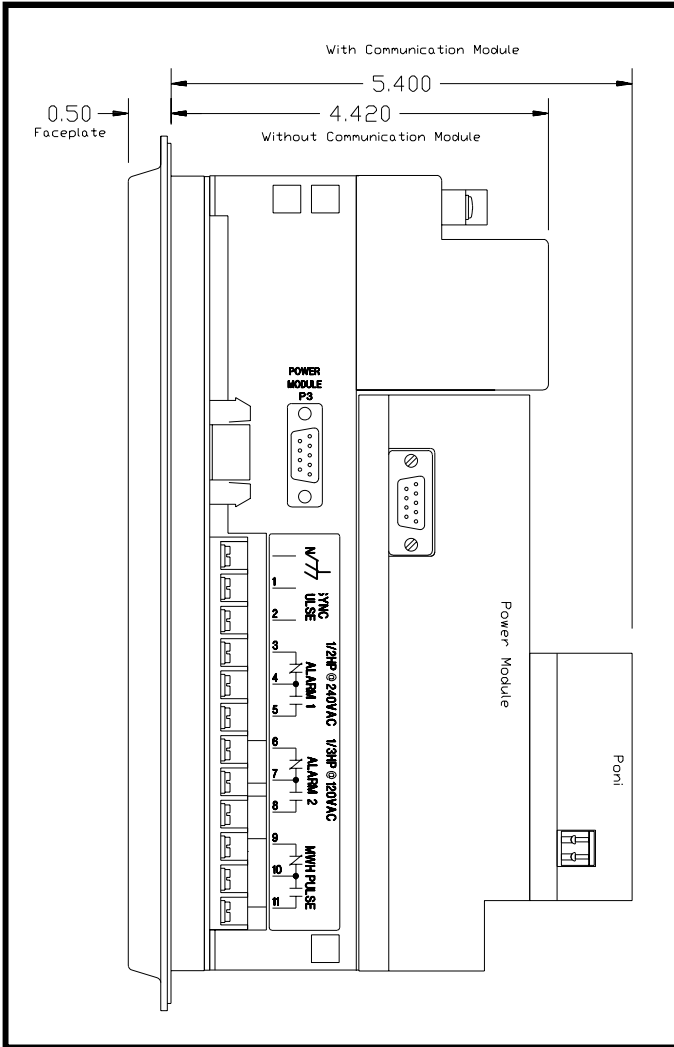
Place the IQ DP-4000 through the cutout in the panel, making sure that the operator panel faces out. Use the 0.5" screws that are included with the unit, and be sure to start the screws from the inside of the panel so they go through the metal first.

The IQ DP-4000 has ten places to attach the unit to the door. While the holes are not threaded, do not use a tap since this removes excess plastic from the holes. This leaves less threaded material to secure the unit to its mounting panel.

Be careful not to over-tighten. For initial installation, 8 in-lbs. of torque is sufficient for the 10 self-tapping screws that are supplied with the unit. If for some reason the screws are replaced, limit the torque to 2 in-lbs. or carefully tighten by hand.



**Figure 4.1 Chassis Cutout Dimensions (inch [mm])**



**Figure 4.2 Side Profile Depth Dimensions**

**4.3 MOUNTING THE POWER SUPPLY MODULE SEPARATELY (OPTIONAL)**

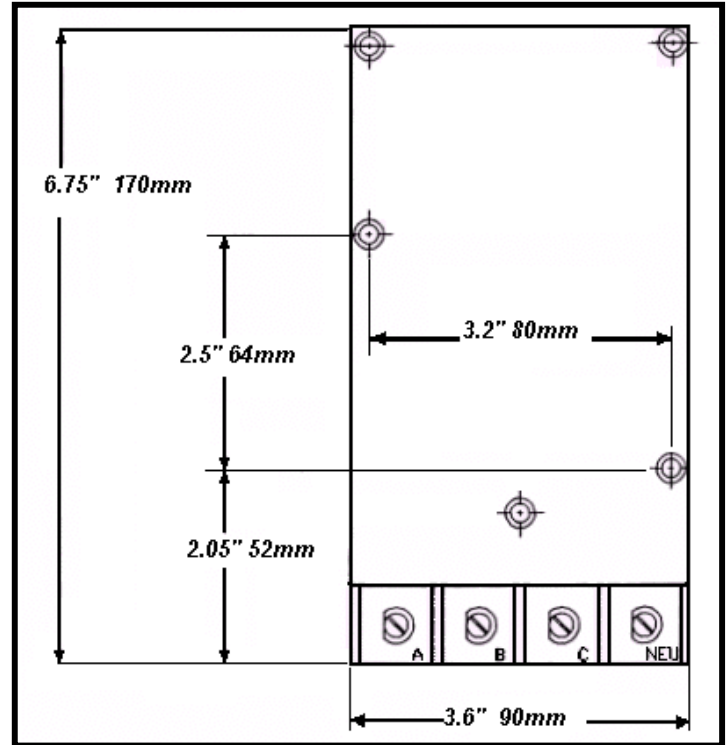
The IQ DP-4000 uses one of two power modules, a 3-Phase power module or a separate source power supply module:

- A 3-Phase power module (Models 4030 and 4130) receives its power from the same source it monitors. The advantage is that the IQ DP-4000 does not need a separate power source to run.
- The IQ DP-4000, equipped with a separate source or dc power supply module (Models 4010, 4110 and 4020, 4120), receives power from a source other than the one it monitors. The advantage to these styles is that if there is a loss of power to the monitored system, the IQ DP-4000 will not lose power. You may mount any of the power modules separately from the chassis. If you do, check that:

- The location allows for a cable connection between the IQ DP-4000 chassis and the power module using either the 36 in. (91cm)

or the 45 in. (114cm) Extension Cable Option

- The separated power module can physically fit in the desired location (See clearance dimensions in Figure 4.3)
- To separate the power module from the IQ DP-4000, remove the two screws that secure it to the IQ DP-4000. Use the power module as a drilling template at the new location. Remount it in the properly drilled and tapped holes, using the two 8-32 screws.



**Figure 4.3 Power Module Dimensions**

**4.4 WIRING**

When you wire the IQ DP-4000, you must follow a suitable wiring plan drawing. A wiring plan, created either by you or your OEM, describes all electrical connections between the IQ DP-4000 and the machine or process equipment. All wiring must conform to applicable federal, state, and local codes.

Shorting blocks for CTs and switches or circuit breakers for voltage connections are recommended near the equipment for ease of installation.



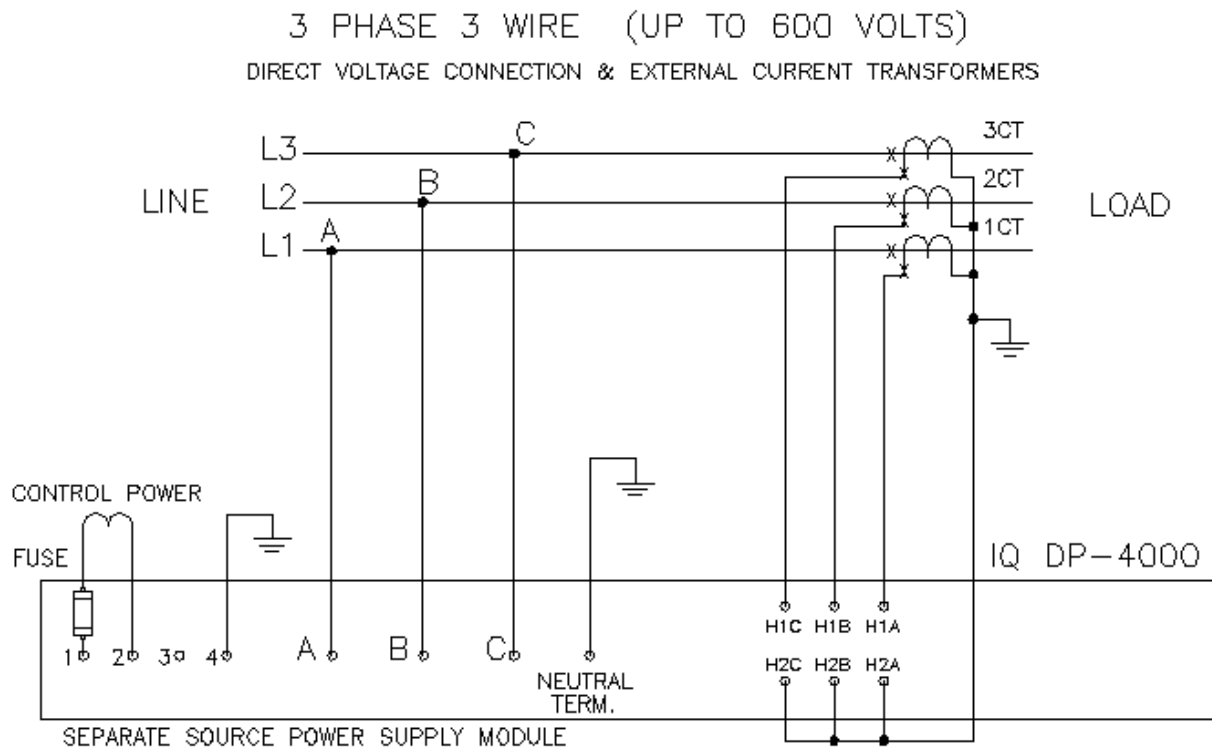
**ENSURE THAT THE INCOMING AC POWER AND ALL 'FOREIGN' POWER SOURCES ARE TURNED**

**OFF AND LOCKED OUT BEFORE PERFORMING ANY WORK ON THE IQ DP-4000 OR ITS ASSOCIATED EQUIPMENT. FAILURE TO OBSERVE THIS PRACTICE CAN RESULT IN SERIOUS OR EVEN FATAL INJURY AND/OR EQUIPMENT DAMAGE.**

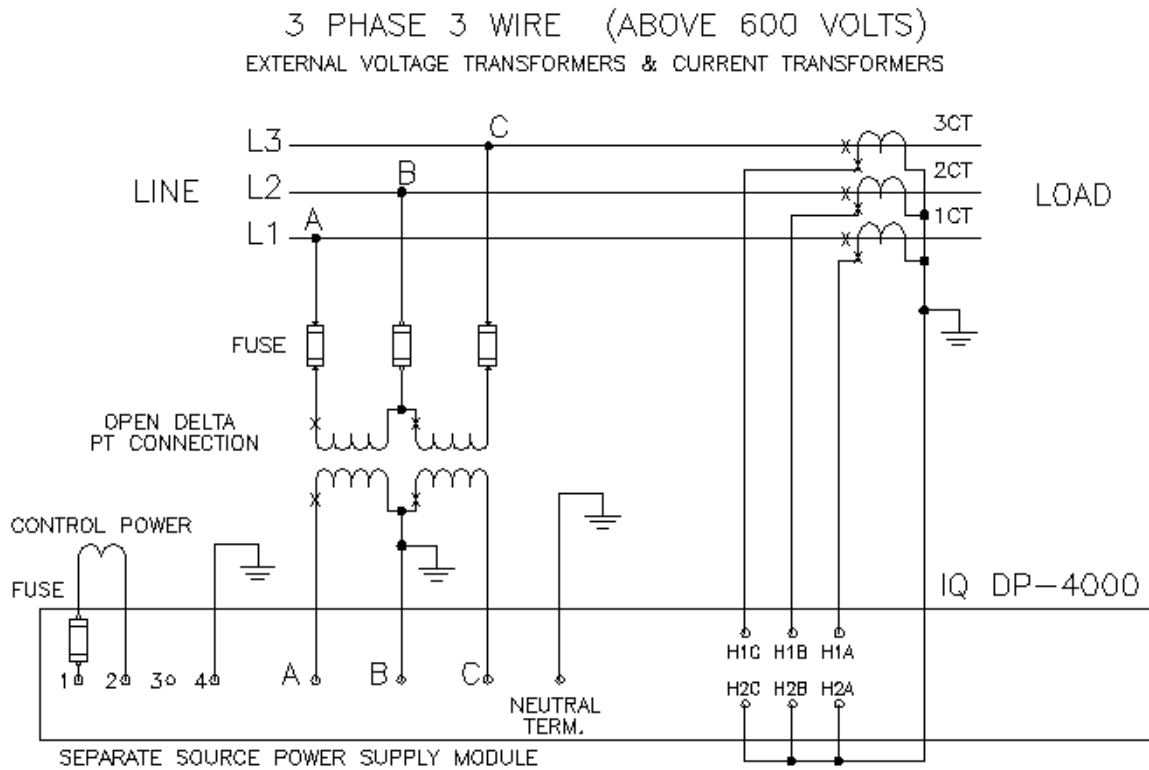
Figures 4.4 - 4.15 show typical wiring plans. When referring to the figures, note the following:

1. Phasing and polarity of the AC current inputs and the AC voltage inputs and their relationship are critical to the correct operation of the wattmeter.
2. The incoming AC line phases A, B, and C connect from three external potential transformers (PT's) to the AC line connection terminals on the chassis (above 600V).

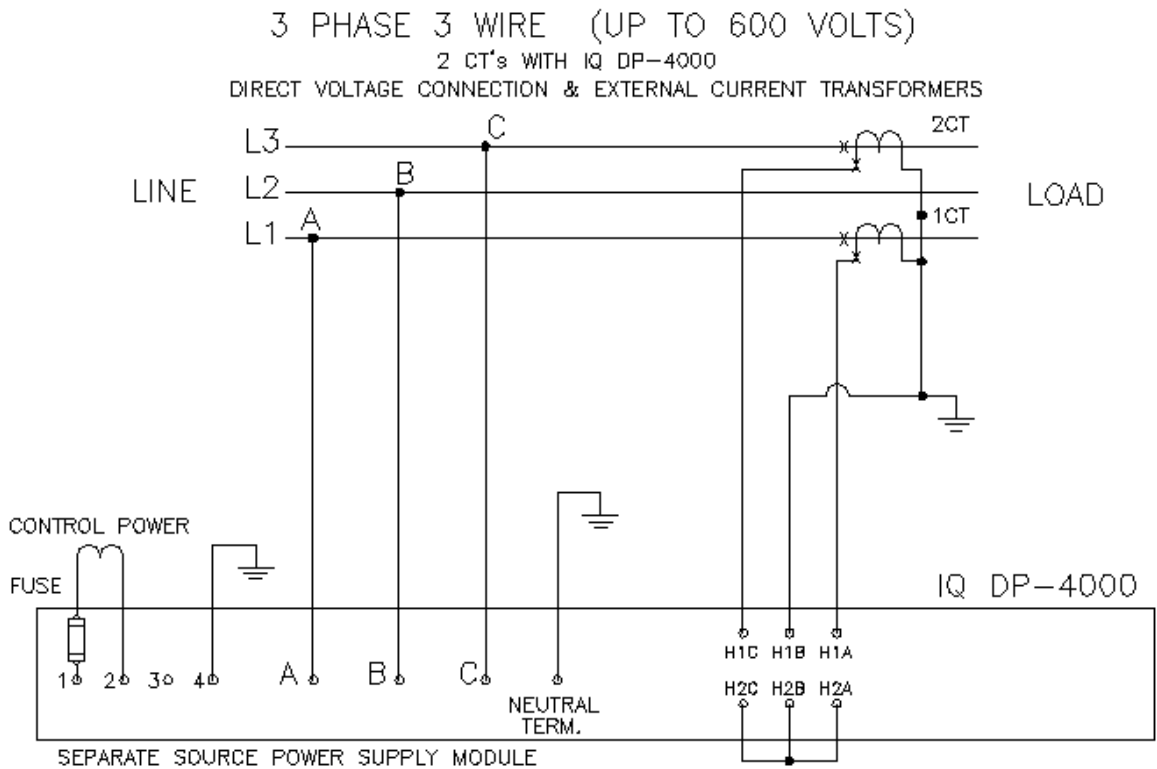
3. You can use NO and NC contacts from the Relays to control external devices. These contacts are rated at 10 amps for 120/240 VAC or 30 VDC.
4. The wires connecting to the IQ DP-4000 must not be larger than AWG No. 14. Larger wires will not connect properly with the various terminal blocks.
5. Keep the wiring between the current transformers and the IQ DP-4000 as short as possible (200 feet max.). Whenever possible, route these lines away from other AC lines and inductive devices. If the lines must cross other AC lines, cross them at right angles.
6. The protective functions of the IQ DP-4000 (with the optional I/O module) directly control the Relays, as described in Section 5.
7. Connect the sync pulse terminals to the dry contact input only. The 24VDC is supplied by the IQ DP-4000 on Terminal 1.



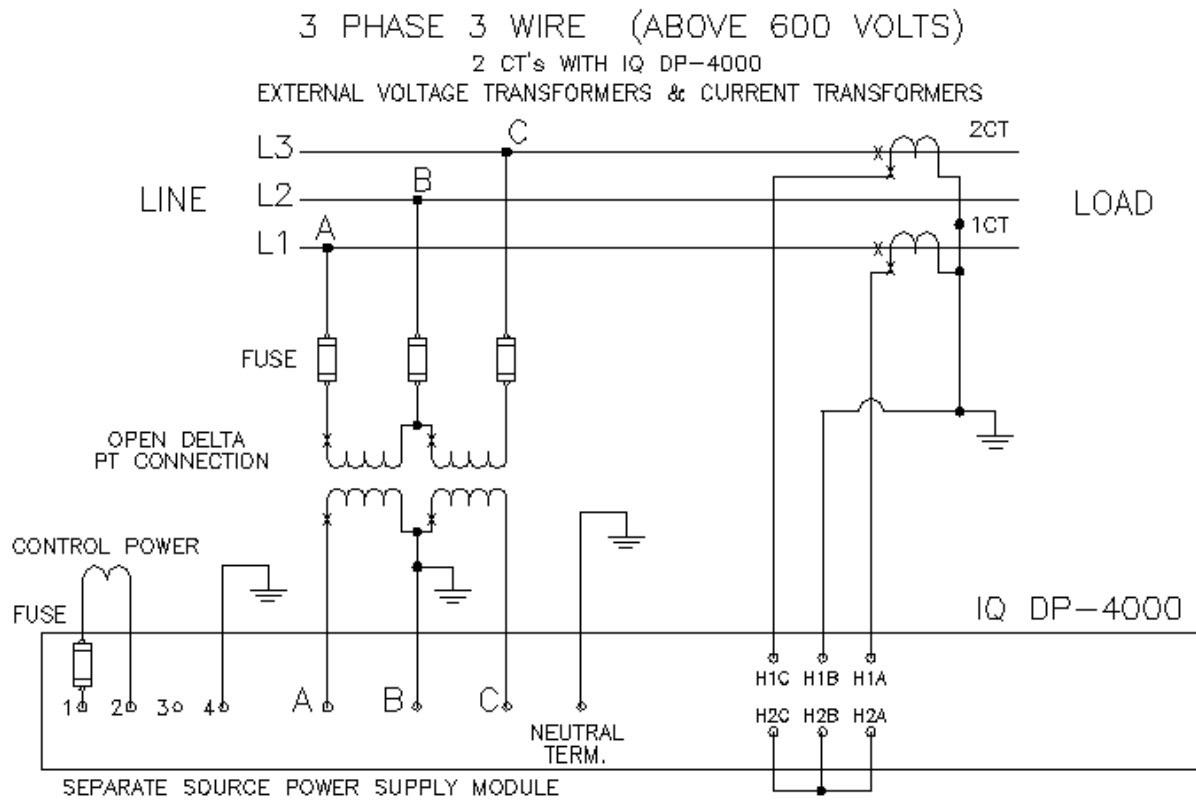
**Figure 4.4 3-Phase, 3 Wire (up to 600 volts) Wiring Diagram (Separate Source)**



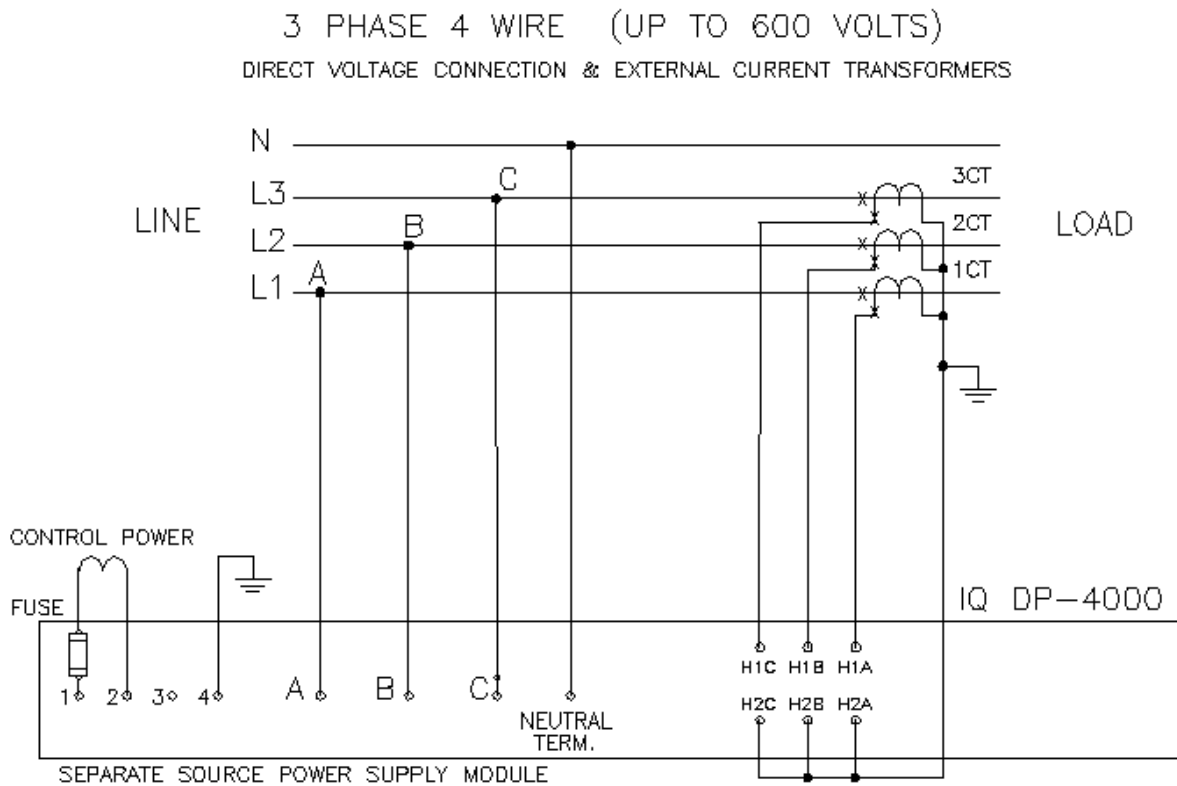
**Figure 4.5 3-Phase, 3-Wire (above 600 volts) Wiring Diagram (Separate Source)**



**Figure 4.6 3-Phase, 3-Wire (up to 600 volts) Wiring Diagram (Separate Source, 2 CTs)**

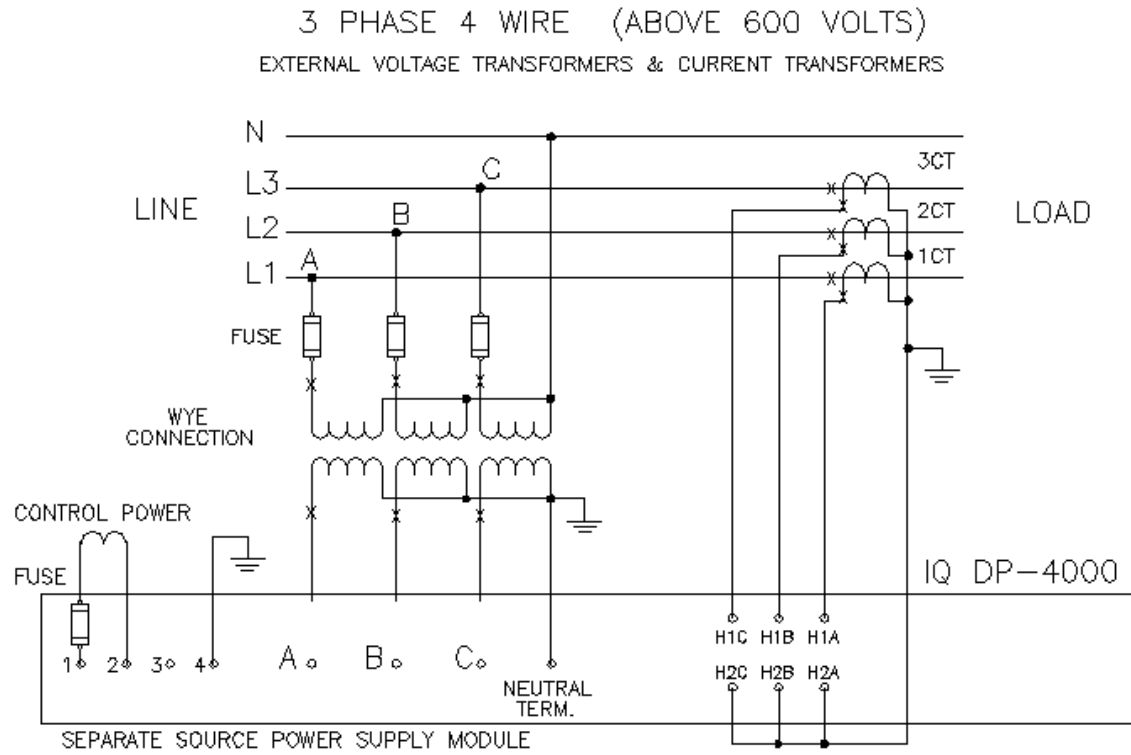


**Figure 4.7 3-Phase, 3-Wire (above 600 volts) Wiring Diagram (Separate Source, 2 CTs)**

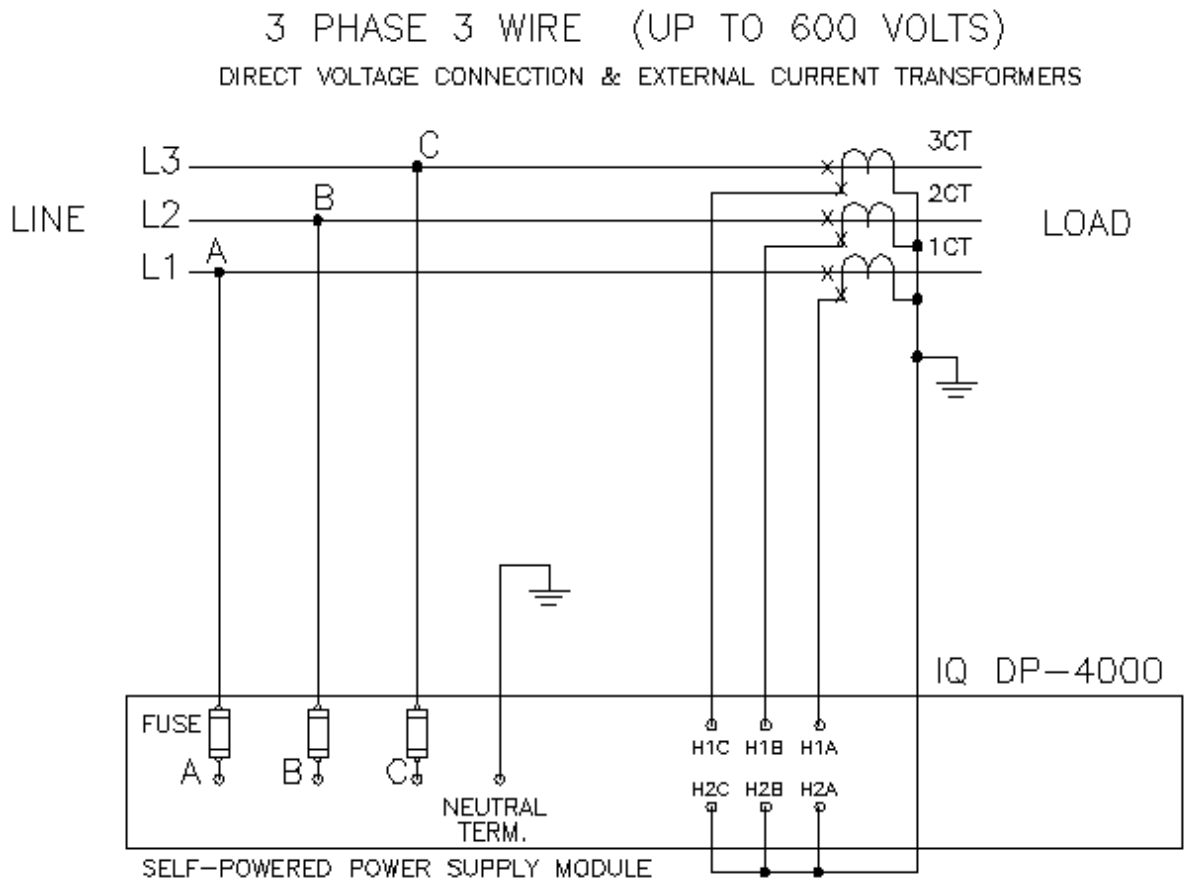


**Figure 4.8 3-Phase, 4-Wire (up to 600 volts) Wiring Diagram (Separate Source)**

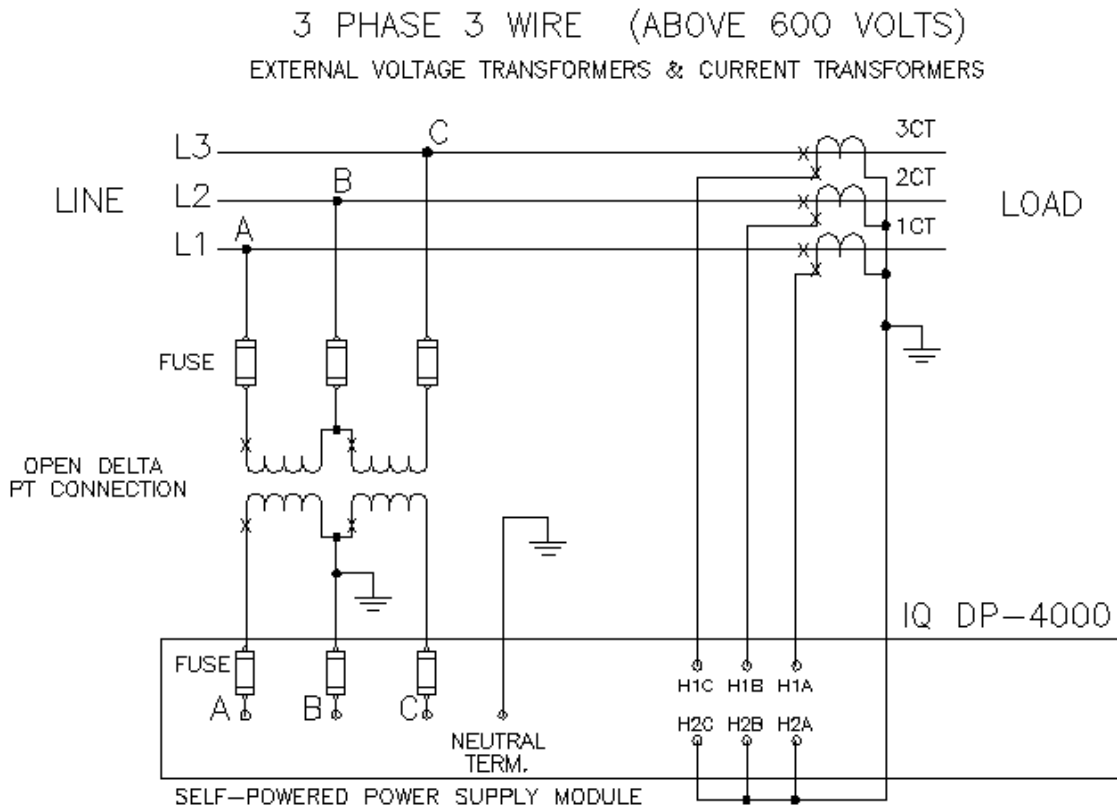




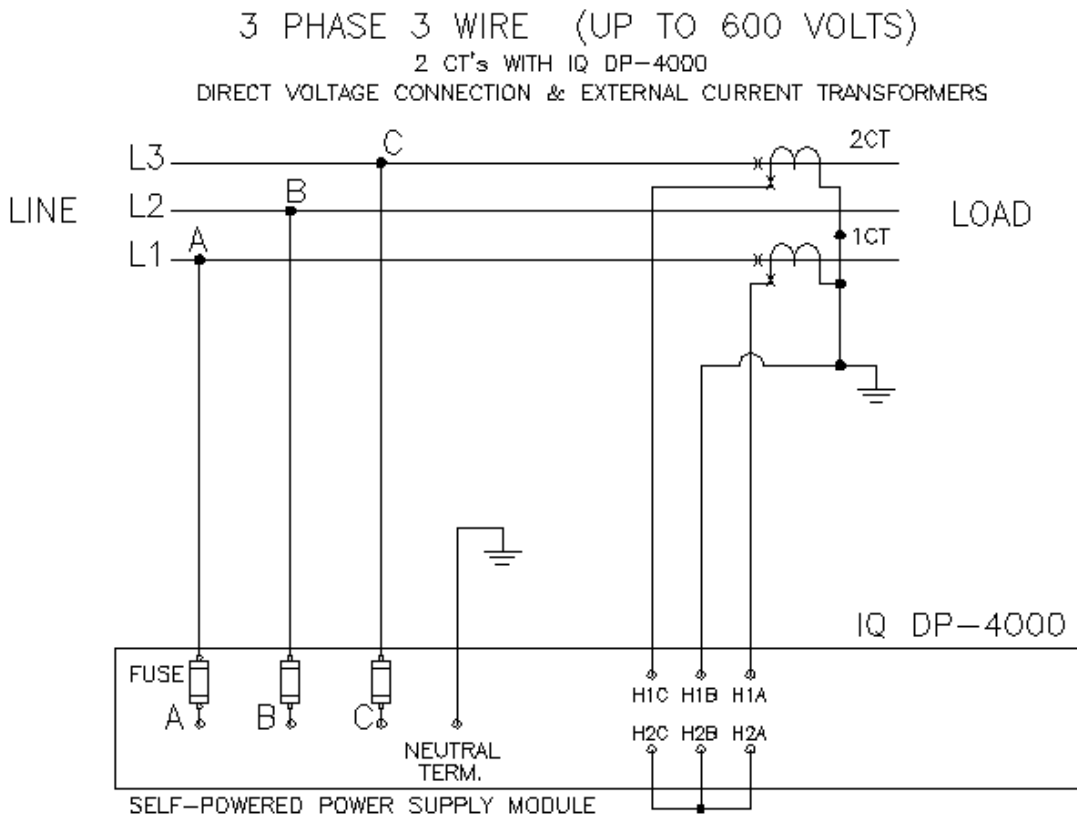
**Figure 4.9 3-Phase, 4-Wire (above 600 volts) Wiring Diagram (Separate Source)**



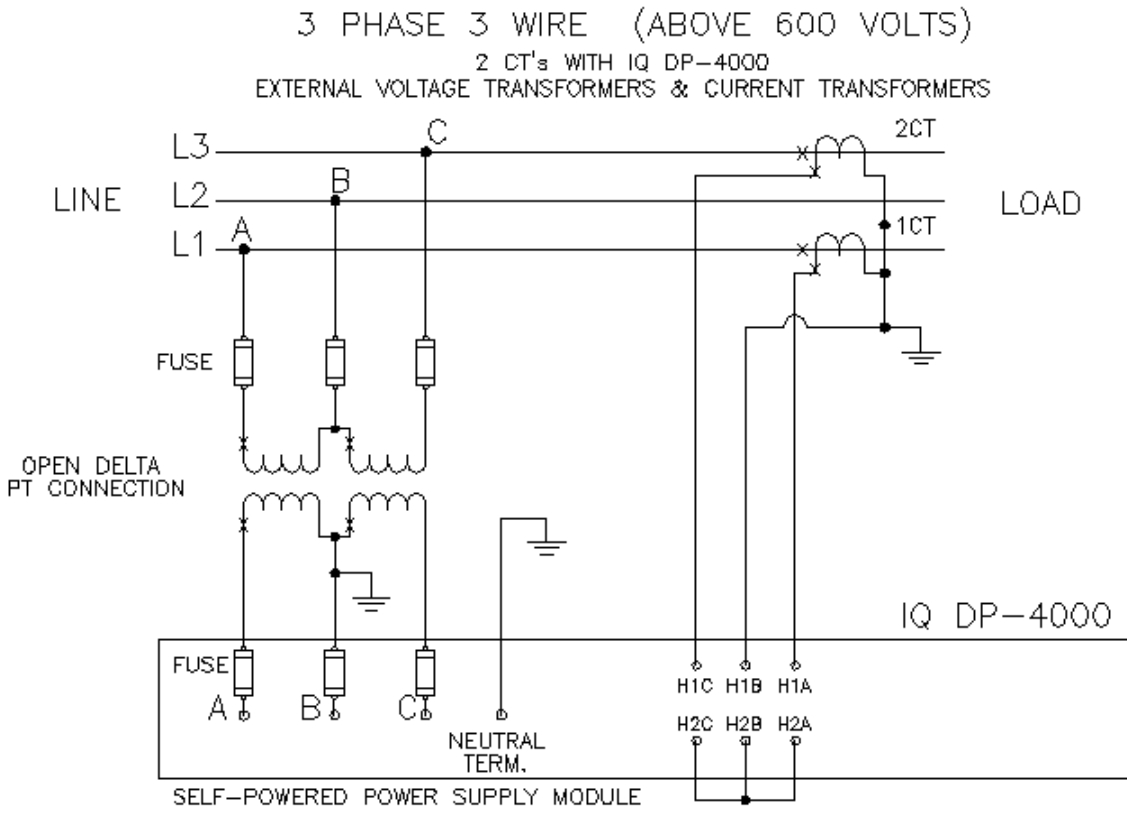
**Figure 4.10 3-Phase, 3-Wire (up to 600 volts) Wiring Diagram**



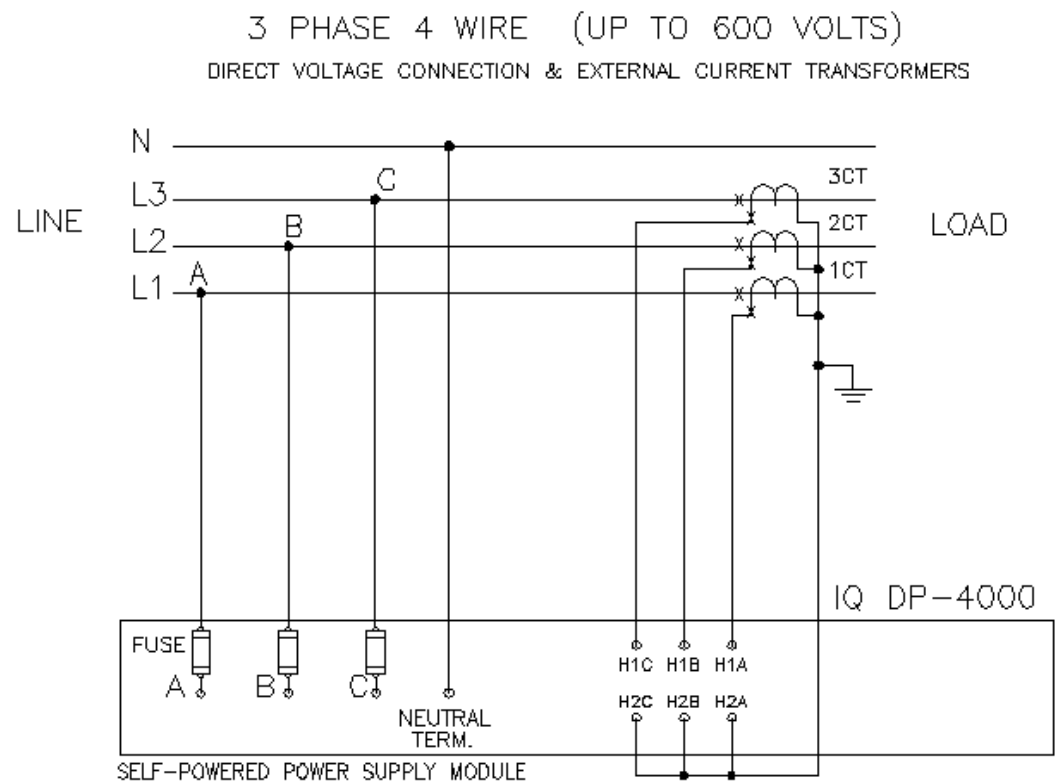
**Figure 4.11 3-Phase, 3-Wire (above 600 volts) Wiring Diagram**



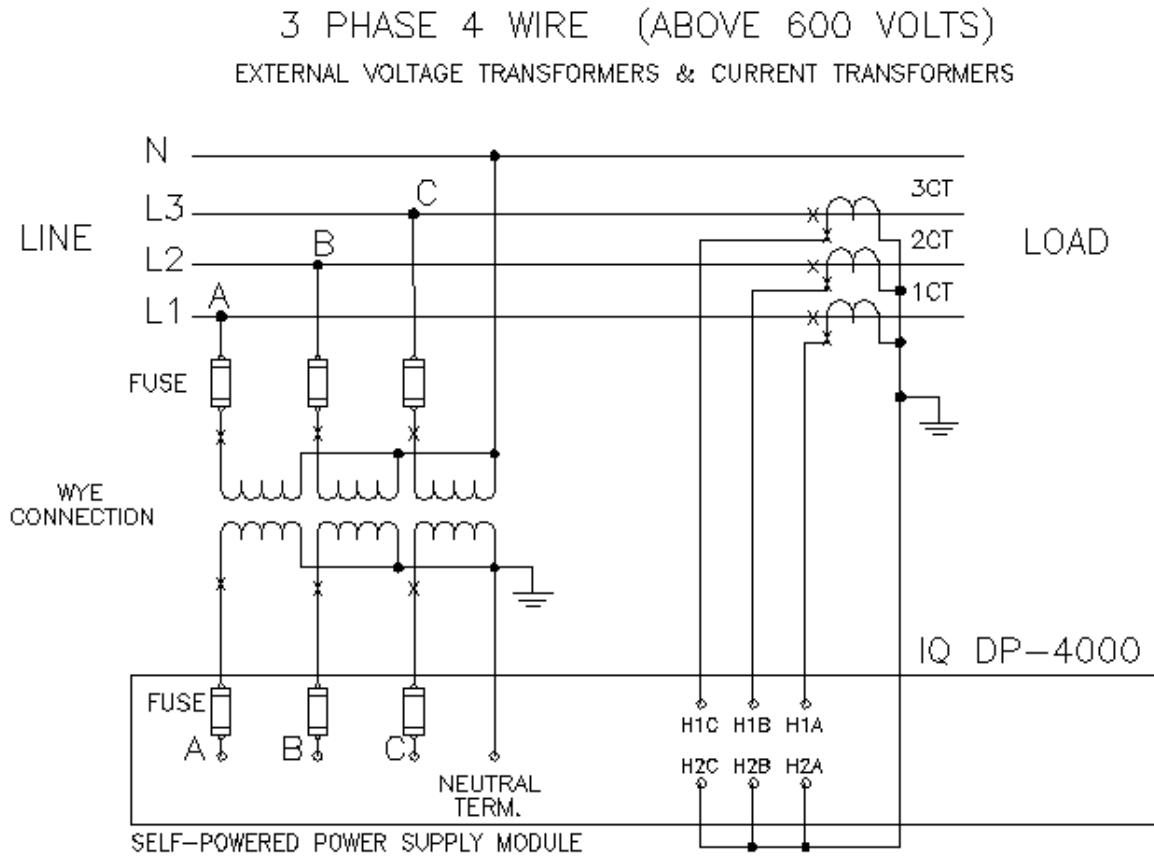
**Figure 4.12 3-Phase, 3-Wire (up to 600 volts) Wiring Diagram (2 CTs)**



**Figure 4.13 3-Phase, 3-Wire (above 600 volts) Wiring Diagram ( 2 CTs)**



**Figure 4.14 3-Phase, 4-Wire (up to 600 volts) Wiring Diagram**



**Figure 4.15 3-Phase, 4-Wire (above 600 volts) Wiring Diagram**

**4.5 INITIAL STARTUP**

Follow the initial startup procedure before and when you first apply AC power to the IQ DP-4000. Use this as a checklist to be sure you do not miss any steps.

**⚠ WARNING**

**THE FOLLOWING STARTUP PROCEDURES MUST BE PERFORMED ONLY BY QUALIFIED PERSONNEL WHO ARE FAMILIAR WITH THE IQ DP-4000 AND ITS ASSOCIATED ELECTRICAL AND/OR MECHANICAL EQUIPMENT. FAILURE TO OBSERVE THIS CAUTION CAN RESULT IN SERIOUS INJURY OR EVEN DEATH.**

**⚠ CAUTION**

**THE CHASSIS GROUND ON THE IQ DP-4000 OR SEPARATE-SOURCE POWER MODULE MUST BE WIRED TO GROUND FOR PROPER OPERATION. FAILURE TO DO SO RESULTS IN INACCURATE READINGS.**

**DURING INITIAL POWER APPLICATION**

To apply AC power to the IQ DP-4000 for the first time:

1. Verify that the AC power is off.
2. Verify that the line-to-line voltages fall within the correct range, as noted on the wiring plan drawing.
3. Check that all wiring is correct according to the wiring plan drawings and that the chassis is grounded.
4. When possible, lockout any foreign power sources and disable the IQ DP-4000 until all other machines or processes are started and thoroughly checked.
5. Restore AC power and verify the operator panel functions, after an initial delay, as follows:
  - The IA Amps LED lights.
  - The Display Window shows the actual line phase A amperes.
6. Set all Setpoint Switches according to the Master Setpoint Record Sheet (Appendix B).

**5.1 INTRODUCTION**

This section identifies all of the programmable functions of the IQ DP-4000. The device is programmed by specifying setpoint values for functions you want monitored. Setpoints are entered using the Save button (S1), Setpoint Switches (S2), Rotary Select Switch (S3), and are displayed via the Setpoint Display LED Bank (DS30) (see Figure 2.2). Set the Rotary Select Switch (S3) to 0 when you are finished programming.

You use the Setpoint switches (S2) in conjunction with the Rotary Select switch (S3) to program setpoint values specific to your needs. Table 5.A, Setpoint Master Record Sheet, lists all of the possible functions that may be set. The left column lists the 16 Rotary Select Switch Positions and the top row lists the Setpoint Switches. Appendix B contains a blank Master Setpoint Record Sheet for recording your setpoint values. Use the details in this section to define your setpoint values and record the values in the blank

Rotary Select Switch (S3)	Setpoint Switches (S2)							
	S2.1	S2.2	S2.3	S2.4	S2.5	S2.6	S2.7	S2.8
S3.0	Test Position—When you are not programming the unit, turn the Rotary Select Switch to 0.							
S3.1	System Configuration	Frequency	Nominal AC Line Voltage				Voltage Transformer Ratio	Current Transformer Primary
S3.2	Voltage Transformer Ratio							
S3.3	Current Transformer Primary							
S3.4	Phase Sequence	Power Demand Fixed/Sliding	Power Demand Time Interval			Current Demand Time Interval		
S3.5	Reset Energy	Energy Resolution	Not Used			Var/Power Factor Sign	Discrete Input	Sync Pulse
S3.6	Alarm 1 Relay Mode	Alarm 1 Latch/Unlatch	Alarm 1 Overvoltage	Alarm 1 Undervoltage	Alarm 1 Voltage Phase Loss	Alarm 1 Voltage Phase Unbalance	Alarm 1 Voltage Phase Reversal	Alarm 1 Current Phase Loss
S3.7	Alarm 2 Relay Mode	Alarm 2 Latch/Unlatch	Alarm 2 Overvoltage	Alarm 2 Undervoltage	Alarm 2 Voltage Phase Loss	Alarm 2 Voltage Phase Unbalance	Alarm 2 Voltage Phase Reversal	Alarm 2 Current Phase Loss
S3.8	Alarm 1 Disable/Enable	Alarm 1 Trip Delay			Alarm 1 Reset Delay			Alarm 1 Overvoltage Detection
S3.9	Alarm 1 Overvoltage Detection		Alarm 1 Undervoltage Detection			Alarm 1 Voltage Phase Unbalance Detection		
S3.A	Alarm 2 Disable/Enable	Alarm 2 Trip Delay			Alarm 2 Reset Delay			Alarm 2 Overvoltage Detection
S3.B	Alarm 2 Overvoltage Detection		Alarm 2 Undervoltage Detection			Alarm 2 Voltage Phase Unbalance Detection		
S3.C	Alarm 1 Reset Threshold			Alarm 2 Reset Threshold			PowerNet Programming	DP-4000 / DP - 2 Mode
S3.D	Pulse Initiator Load Shed	Pulse Initiator Parameter			Load Shed /Restore Load Range Settings			
S3.E	Load Shed /Restore Load Range							
S3.F	Load Shed Parameter				Pulse Initiator Rate			

**Table 5.A Setpoint Master Sheet (The Most Important Page in This Manual)**

## Setpoint Master Record Sheet.

In this section, the available functions are broken into three categories -- general system (Table 5.B), alarm (Table 5.C) and optional I/O (Table 5.D). In each table, the functions are listed in the first column. The second column of the table identifies the corresponding section that describes valid setpoint values.

General System Functions	Section
System Configuration 3/4 Wire	5.3
Frequency Selection - 50/60 Hz	5.4
Nominal AC Line Voltage setting	5.5
Voltage Transformer Ratio	5.6
Current Transformer Primary	5.7
Phase Sequence - ABC/CBA	5.8
Demand Parameters	
Power Demand, Fixed/Sliding	5.9.1
Power Demand Time Interval	5.9.2
Current Demand Time Interval	5.9.3
Energy Setpoints	
Reset Energy - Enable/Disable	5.10.1
Energy Resolution	5.10.2
Var/Power Factor sign convention (+ or -)	5.11
PowerNet Network Programmable	5.13
DP-4000/DP-2 Mode	5.14

**Table 5.B General System Functions**

Alarm Functions	Section
Relay Mode 1/Mode 2	5.12.1
Latched/Unlatched Alarm	5.12.2
Activate on Overvoltage	5.12.3
Activate on Undervoltage	5.12.4
Activate on Voltage Phase Loss	5.12.5
Activate on Voltage Phase Unbalance	5.12.6
Activate on Voltage Phase Reversal	5.12.7
Activate on Current Phase Loss	5.12.8
Enable/Disable Alarm	5.12.9
Alarm Delay	5.12.10
Alarm Reset Delay	5.12.11
Overvoltage Detection Level	5.12.12
Undervoltage Detection Level	5.12.13
Voltage Phase Unbalance Detection	5.12.14
Alarm Reset Threshold	5.12.15

**Table 5.C Alarm Functions**

Optional I/O Functions	Section
Discrete Input Setup	5.15.1
Sync Pulse Setpoints	5.15.2
Pulse Initiator/Load Shed	
Pulse Initiator Settings, Parameter	5.15.3.1
Load Shed Range	5.15.3.2
Load Shed Parameter	5.15.3.3
Pulse Initiator Settings, Rate Selection	5.15.3.4

**Table 5.D Optional I/O Functions**

## 5.2 SETTING SETPOINT SWITCHES

To program the IQ DP-4000, you must determine which setpoints you want and then **record and verify all the setpoints before starting any entry**. Appendix B contains both a blank Setpoint Master Record Sheet for recording your setpoint values and, for each function, a table displaying the required Select Switch and Setpoint Switches. A Configuration Disk is included with each IQ DP-4000. This disk contains a Windows95/3.XX tool that assists you with the proper switch settings; however, it does not download settings to the meter.

### CAUTION

**BE CAREFUL WHEN REPROGRAMMING THE IQ DP-4000. WHEN YOU CHANGE THE VALUES FOR ONE SETPOINT, BE SURE THAT THE SETPOINT SWITCHES FOR THAT SELECT SWITCH ARE SET TO THE PROPER SETTINGS. WHEN YOU PRESS THE SAVE BUTTON, ALL OF THE SETTINGS FOR THAT SWITCH CHANGE TO THE NEW SETTINGS.**

The Setpoint Switches (S2) are located on a strip at the rear right portion of the chassis just below the Setpoint Display LED bank (DS30). Directly below them is the Rotary Select Switch (S3) and the Save button (S1). See Figure 2.2 (p.4).

***It is essential that all of the desired Setpoint Switch settings for each Select Switch are recorded in the Master Setpoint Record Sheet before programming!***

To program the Setpoint Switches:

1. **Use the Master Setpoint Record Sheet** as a guide for the settings.
2. Turn Select Switch to the desired position (S3.1-F).
3. Set the Setpoint Switches (S2) based on the information in the **Master Setpoint Record Sheet** by sliding the Setpoint Switch to the left to turn the switch off, or to the right to turn it on.

4. Press the Save button briefly to see if the LED's light properly. The corresponding LED will light if the switch is turned on.
5. When the Setpoint Switches for that Rotary Select Switch are all in the proper location, press and hold the Save button until the tenth LED lights. The settings are now stored permanently in the device's non-volatile memory.
6. Repeat steps 1 to 5 for each Rotary Select Switch position.
7. When you are done, set the Rotary Select Switch to the 0 position.

**5.2.1 Setpoint Switch Programming Example**

As an example, let us program the device to accept 100:5 current transformers (CT's). To do this:

1. Turn to Appendix A of this manual and look for the size of CT's that are being used (100:5).

■ = OFF   □ = ON   ▒ = Not Applicable

**Select Switch(S3)      Setpoint Switch (S2)**

Position	1	2	3	4	5	6	7	8
1	▒	▒	▒	▒	▒	▒	▒	▒
3	▒	▒	■	■	▒	■	▒	▒

**Table 5.E Setpoint Switch Settings**

2. Turn the Rotary Select Switch to position 1 (**S3.1**). As stated in Appendix A, set the Setpoint Switches (**S2**) as shown in Table 5.E (gray indicates reserved for other setpoints, black indicates OFF and white indicates ON).
3. Push the eighth Setpoint Switch to the left (off). When you press the Save button in step 9, you will save all 8 switches and overwrite any previous settings made for **S3.1**.
4. Briefly press the Save button to confirm the settings. The 8th LED will not light indicating the off position.
5. Press and hold the Save button until the tenth LED lights. The setting for Rotary Select Switch position 1 (**S3.1**) is now permanently stored in the device's long-term memory.
6. Turn the Rotary Select Switch to position 3 (**S3.3**).
7. Push the first, second and fifth Setpoint Switches to the right (on). Push the third, fourth, sixth, seventh, and eighth to the left (off).

8. Briefly press the Save button to confirm the settings. The first, second, and fifth LEDs light indicating they are in the on position.
9. Press and hold the Save button until the tenth LED lights. The setting for Select Switch 3 is now permanently stored in the device's long-term memory.
10. Place the Select Switch to the 0 position.

**5.3 SYSTEM CONFIGURATION SETPOINT**

The IQ DP-4000 monitors either a 3-conductor or 4-conductor AC line. For example, in a 4-wire system, a transformer's secondary winding is wired in a wye configuration, with the XO neutral terminal ground as the fourth wire. In this case, the XO fourth wire connects to the screw terminal on the power supply. Refer to Figures 4.9 and 4.15.

Record the desired Setpoint Switch setting **S2.1**, for Rotary Switch position **S3.1** in Appendix B as follows:

- OFF position for a 3-wire wiring configuration
- ON position for a 4-wire wiring configuration

When you choose the OFF position for the 3-wire configuration, the front panel will not display the 3 line-to-neutral AC line measurements. The measurements not displayed are: **You must set all 8 S2 switches**

- V<sub>A-N</sub> Volts
- V<sub>B-N</sub> Volts
- V<sub>C-N</sub> Volts

**5.4 FREQUENCY SELECTION SETPOINT**

The IQ DP-4000 accepts a nominal line frequency of either 50 or 60 Hz. Record the desired **S2.2**.setting for Rotary Switch position **S3.1**: **Set all 8 S2 switches**

- OFF position for a 50 Hz system
- ON position for a 60 Hz system

**5.5 NOMINAL AC LINE VOLTAGE SETPOINT**

The IQ DP-4000 measures AC line voltage in one of two ways:

- Line-to-line (3 Phase 3 Wire)
- Line-to-neutral (3 Phase 4 Wire)

Based on the wiring configuration for the system, you must set switches to indicate the nominal AC line voltage applied to the AC line terminals. Line-to-neutral

voltages will not be displayed if the IQ DP-4000 is configured as a 3-wire system.

*Note: When external voltage transformers are used, the nominal AC line voltage setting indicates the voltage present on the secondary terminals of the PTs. Also, L-N voltages will not be displayed if the unit is configured as a three-wire.*

Setpoint Switches **S2.(3 to 6)** for Rotary Switch position **S3.1** specify the nominal AC line voltage. Record the desired switch settings according to Table 5.F. Follow the table's line-to-line column when the wiring configuration of the AC line is 3-wire. Use the line-to-neutral column when the AC line configuration is 4-wire.

■ = OFF □ = ON

Voltages (Nominal)		S3.1 Switch Settings (Set all 8 S2 switches)			
Line-to-Line	Line-to-Neutral	S2.3	S2.4	S2.5	S2.6
100	58	on	on	on	on
110	64	off	off	off	off
120	69	on	off	off	off
208	120	off	on	off	off
220	127	on	on	off	off
240	138	off	off	on	off
380	219	on	off	on	off
416	240	off	on	on	off
460	266	on	on	on	off
480	277	off	off	off	on
575	332	on	off	off	on
600	336	off	on	off	on
600	336	Any other selection			

**Table 5.F AC Line Voltage**

**5.6 VOLTAGE TRANSFORMER RATIO SETPOINT**

Some systems may include optional, user-provided potential voltage transformers (this is required above 600V). You must take these ratios into account by using Setpoint Switches **S2.7** for Rotary Switch position **S3.1**, and the eight Setpoint Switches **S2.(1 to 8)** for Rotary Switch position **S3.2**. See Appendix A for a listing of the available PT ratios, and their corresponding settings. **You must set all 8 S2 switches.**

**5.7 CURRENT TRANSFORMER PRIMARY SETPOINT**

The primary winding of the user-provided external current transformers can vary from 5 amps to 12,800 amps; the secondary winding is assumed to be 5 amps. Setpoint Switches **S2.8** for Rotary Switch position **S3.1**,

and the eight switch settings **S2.(1 to 8)** for Rotary Switch position **S3.3**, must correspond to the external current transformer's primary rating. See Appendix A for a listing of the available CT primary ratings, and their corresponding settings.

**5.8 PHASE SEQUENCE SETPOINT**

The IQ DP-4000 can be programmed to correspond to either a nominal ABC or CBA sequence, by a single Setpoint Switch **S2.1** for Rotary Switch position **S3.4**. A power system with an ABC sequence has phase A leading phase B by 120 degrees, and phase B leading phase C by 120 degrees. A system with a CBA sequence has phase C leading phase B by 120 degrees, and phase B leading phase A by 120 degrees.

Record the desired setting for **S2.1** for Rotary Switch position **S3.4**: **(You must set all 8 S2 switches)**

- OFF position for an ABC sequence
- ON position for a CBA sequence

**5.9 DEMAND SETPOINTS**

If you set up the IQ DP-4000 to use an internal sync pulse (see Section 5.15.2 p.34), you must determine the type of demand, and time interval for the demand window. The present demand and peak demand are computed for the following parameters:

- Current Related Parameters. For the current related parameters, the demand calculation is always based on a fixed window. Section 5.9.3 describes programming the current demand times. The current related parameters are:
  - I<sub>A</sub> Amps
  - I<sub>B</sub> Amps
  - I<sub>C</sub> Amps
- Power Related Parameters. For the power related parameters, the demand can be based on either a fixed or sliding window. See Section 5.9.1 for selecting a fixed or sliding demand window and Section 5.9.2 for programming the power related demand times. The power related parameters are:
  - Watts
  - Vars
  - VA



**5.9.1 Power Demand, Fixed/Sliding**

The IQ DP-4000 is programmed for the power related demand to correspond to either a fixed or sliding window.

- Fixed Power Demand. With a fixed demand window, the demand calculation is based on, and updated at, the user-selected time interval. For example, if you select a 15-minute demand window, a new demand will compute every 15 minutes, based on the energy used during the last 15 minutes.
- Sliding Power Demand. For a sliding window, the demand calculation is based on the user-selected interval time, and is updated every minute. For example, if you select a 15-minute demand window, the calculated demand is based upon the previous 15 minutes, but is updated every minute.

Record the desired setting of Setpoint Switch **S2.2** for Rotary Switch position **S3.4**:

- OFF position for the sliding power demand window
- ON position for the fixed power demand window

**5.9.2 Power Demand Time Interval**

Setpoint Switches **S2.(3 to 5)** for Rotary Switch position **S3.4** determine the time interval, in minutes, that the consumption sampling for the power related demand calculations are based. Table 5.G shows the settings for selecting the power demand interval.

■ = OFF □ = ON

Time Interval (minutes)	S3.4 Settings (Set all 8 S2 switches)		
	S2.3	S2.4	S2.5
5	off	off	off
10	on	off	off
15	off	on	off
20	on	on	off
25	off	off	on
30	on	off	on
45	off	on	on
60	on	on	on

**Table 5.G Power Demand Intervals for Watts, Vars and VA**

**5.9.3 Current Demand Time Interval**

Setpoint Switches **S2.(6 to 8)** for Rotary Switch position **S3.4** determine the time interval, in minutes, that the consumption sampling for the current related demand calculations are based. Table 5.H shows the settings for selecting the current demand time intervals.

■ = OFF □ = ON

Time Interval (minutes)	S3.4 Settings (Set all 8 S2 switches)		
	S2.6	S2.7	S2.8
5	off	off	Off
10	on	off	Off
15	off	on	off
20	on	on	off
25	off	off	on
30	on	off	on
45	off	on	on
60	on	on	on

**Table 5.H Demand Sampling Interval for I<sub>A</sub>, I<sub>B</sub>, and I<sub>C</sub>**

**5.10 ENERGY SETPOINTS**

**5.10.1 Reset Energy from Faceplate Setpoint**

This setpoint enables or prevents you from resetting the energy values (Watt-hours, Var-hours, and VA-hours) from the faceplate. Record the desired setting of Setpoint Switch **S2.1** for Rotary Switch position **S3.5**: **(Set all 8 S2 switches)**.

- OFF position to prevent resetting an energy value from the faceplate
- ON position to enable resetting at the faceplate. To reset an energy value from the faceplate, you select the parameter (Metered Watt-hours, Var-hours, or VA-hours), and then hold down the Reset button until the value is 0.

**5.10.2 Energy Resolution**

The IQ DP-4000 can be programmed to display energy readings in KILO or MEGA energy units. A single Select switch sets the energy resolution. The energy value rolls-over to zeros when it exceeds 999999.

Record the desired setting of Setpoint switch **S2.2** for Rotary Switch position **S3.5**: **(Set all 8 S2 switches)**.

- OFF position for KILO energy units
- ON position for MEGA energy units

**5.11 VAR/POWER FACTOR SIGN CONVENTION SETPOINT**

This setpoint selects the sign convention (+ or -) for the Var and the Power Factor values. The sign conventions can be either negative or positive.

- A negative sign convention corresponds to:
  - Inductive Load = Negative Var and Power Factor Values (Lagging Power Factor)
  - Capacitive Load = Positive Var and Power Factor Value(Leading Power Factor)
- A positive sign convention corresponds to:
  - Inductive Load = Positive Var and Power Factor Values (Lagging Power Factor)
  - Capacitive Load = Negative Var and Power Factor Values (Leading Power Factor)

Power engineers typically use the positive sign convention as the standard convention; the negative sign convention is mathematically correct.

Figures 3.2 and 3.3 illustrate the two Var and Power Factor sign conventions.

**S2.6** setting for Rotary Select Switch position **S3.5:** (Set all 8 S2 switches).

- OFF position for a negative sign convention
- ON position for a positive sign convention

**5.12 ALARM FUNCTIONS - GENERAL**

The DP-4000 has two independent alarms, Alarm 1 and Alarm 2. The faceplate of the IQ DP-4000 has two LEDs to indicate the state of each of these alarms. A “steady-on” LED indicates an active alarm. If the optional I/O module is installed, the relays will change state when the corresponding alarm LED is illuminated. Both of the alarms have the features outlined in Table 5.C (p.22).

**5.12.1 Relay Modes Alarm Setpoint**

This setpoint is used only if the IQ DP-4000 is equipped with the optional I/O module. Select one of two different alarm relay reaction modes in response to a number of operating conditions. These are:

- Mode 1. Alarm relay is de-energized normally and energizes during an alarm condition
- Mode 2. Alarm relay is energized normally and de-energizes during a loss of AC control power

You must select one of these two modes for each alarm. Your choice depends on the desired effect of an AC power loss on an application, as described in

Paragraph 5.12.13 (p.29). See Table 5.I for setting the alarm modes for the relays.

**5.12.1.1 Mode 1**

When alarm mode 1 is selected, the alarm relay will energize only on an alarm condition. The alarm relay is in the de-energized state:

- When the IQ DP-4000 is not powered
- During normal operation, with no alarms active (the corresponding Alarm LED is not “steady-on” when viewing from the faceplate)

During **normal operation**, when the alarm relay is in the de-energized state, the **normally-closed contacts are closed**.

When an alarm occurs, the normally-closed contacts open, and the normally open contacts close. The advantage of this mode of operation is that if a failure of the IQ DP-4000 occurs (a loss of power), the relay will remain in the same state, as if no alarms are active.

*Note: It is your responsibility to choose the NO/NC pair of Alarm Relay contact to perform the desired operation.*

**5.12.1.2 Mode 2**

When alarm mode 2 is selected, the alarm relay will energize after initial power up and de-energize on a trip condition. The alarm relay is in the energized state. This occurs when:

- After the normal AC power-up sequence
- During normal operation, with no alarms active (the corresponding Alarm LED is not “steady-on” when viewing from the faceplate)

During **normal operation**, when the alarm relay is in the energized state, the **normally-closed contacts are open**.

When an alarm occurs, the normally-closed contacts close, and the normally-open contacts open.

The advantage of this mode of operation is that if a failure of the IQ DP-4000 occurs (a loss of power), the relay will change state, as if an alarm occurs.

Alarm 1		Alarm 2		Position (Set all 8 S2 switches)
S3.6	S2.1	S3.7	S2.1	OFF for Mode 1 ON for Mode 2

**Table 5.I Alarm Relay Mode Setting**

**5.12.2 Latched/Unlatched (Auto-reset) Alarm Setpoint**

This setpoint allows the IQ DP-4000 to operate in one of two ways - the latched mode or the unlatched mode.

See Table 5.J for setting this option.

- Latched Mode. In the latched mode, you can only reset an active alarm manually (either from the faceplate, the reset input, or over PowerNet / IMPACC). The alarm **will not** automatically clear once the reset conditions are met. If the alarm condition still exists, you cannot reset the alarm unless you disable it.
- Unlatched Mode (auto-reset). If an alarm occurs, the DP-4000 will automatically reset the alarm when the reset conditions are met, based on the program settings (for example, reset thresholds and reset delays). The DP-4000 will not reset if the alarm condition still exists.

Alarm 1	Alarm 2	Position (Set all 8 S2 switches)
S3.6	S3.7	OFF for Unlatched
S2.2	S2.2	ON for Latched

**Table 5.J Latched/Unlatched Settings**

**5.12.3 Activate on Overvoltage Alarm Setpoint**

This setpoint activates the selected alarm on an overvoltage condition. When enabled, the IQ DP-4000 compares the metered line-to-line voltage of each phase to the overvoltage detection level (see 5.12.12 p.29), and activates the alarm if the threshold is exceeded for a time greater than the alarm delay on any phase (see 5.12.10 p.28). See Table 5.K for setting this option.

Alarm 1	Alarm 2	Position (Set all 8 S2 switches)
S3.6	S3.7	OFF disables Activate on Overvoltage
S2.3	S2.3	ON enables Activate on Overvoltage

**Table 5.K Activate on Overvoltage Settings**

**5.12.4 Activate on Undervoltage Alarm Setpoint**

This setpoint activates the selected alarm on an undervoltage condition. If enabled, the IQ DP-4000 compares the metered line-to-line voltage of each phase to the undervoltage detection level (see Section 5.12.13), and activates the alarm if the metered voltage is below the threshold for a time greater than the alarm delay on any phase. See Section 5.12.10 (p.28) and Table 5.L for setting this option.

Alarm 1	Alarm 2	Position (Set all 8 S2 switches)
S3.6	S3.7	OFF disables Activate on Undervoltage
S2.4	S2.4	ON enables Activate on Undervoltage

**Table 5.L Activate on Undervoltage Settings**

**5.12.5 Activate on Voltage Phase Loss Alarm Setpoint**

This setpoint activates the selected alarm on a voltage phase loss condition. A voltage phase loss occurs when the line-to-line voltage on any phase is less than 50% of the nominal line voltage.

When this alarm is set, the IQ DP-4000 compares the metered voltage to 50% of the selected nominal voltage (see Section 5.5 p.23), and activates the alarm if a voltage phase loss exists for a time greater than the alarm delay (see 5.12.10 p.28). See Table 5.M for setting this option.

Alarm 1	Alarm 2	Position (Set all 8 S2 switches)
S3.6	S3.7	OFF disables Activate on Voltage Phase Loss
S2.5	S2.5	ON enables Activate on Voltage Phase Loss

**Table 5.M Activate on Voltage Phase Loss Settings**

**5.12.6 Activate on Voltage Phase Unbalance Alarm Setpoint**

This setpoint activates the alarm on a voltage phase unbalance condition. The IQ DP-4000 compares the metered voltage to the voltage phase unbalance detection level (see 5.12.14 p.29), and activates the alarm if the maximum deviation between any two phases of the metered voltage exceeds the threshold for longer than the alarm delay (see 5.12.10 p.28). Table 5.N shows the settings for this option.

Alarm 1	Alarm 2	Position (Set all 8 S2 switches)
S3.6	S3.7	OFF disables Activate on Voltage Phase Unbalance
S2.6	S2.6	ON enables Activate on Voltage Phase Unbalance

**Table 5.N Activate on Voltage Phase Unbalance Settings**

**5.12.7 Activate on Voltage Phase Reversal Alarm Setpoint**

This setpoint activates the alarm on a voltage phase reversal condition. The IQ DP-4000 compares the phase rotation of the metered voltages to the selected phase sequence of the system (see Section 5.8 p.24), and activates the alarm if the order of the phases does not correspond for longer than the alarm delay (see 5.12.10 p.28). See Table 5.O for setting this option.

Alarm 1	Alarm 2	Position (Set all 8 S2 switches)
S3.6 S2.7	S3.7 S2.7	OFF disables Activate on Voltage Phase Reversal ON enables Activate on Voltage Phase Reversal

**Table 5.O Activate on Voltage Phase Reversal Settings**

**5.12.8 Activate on Current Phase Loss Alarm Setpoint**

This setpoint allows the selected alarm to activate on a current phase loss condition. A current phase loss occurs when the current on any one phase is less than 6.25% of the largest current of the other 2 phases. The IQ DP-4000 activates the alarm if a current phase loss exists for longer than the alarm delay (see 5.12.10 p.28). Table 5.P shows the settings for this option.

Alarm 1	Alarm 2	Position
S3.6 S2.8	S3.7 S2.8	OFF disables Activate on Current Phase Loss ON enables Activate on Current Phase Loss

**Table 5.P Activate on Current Phase Loss Settings**

**5.12.9 Enable/Disable Alarm Setpoint**

The alarms disable or enable with a single switch (see Table 5.Q). When you select OFF, the alarm will not activate on any of the six conditions, regardless of the other setpoints. A PowerNet / IMPACC external alarm will, however, activate the alarm.

Alarm 1	Alarm 2	Position (Set all 8 S2 switches)
S3.8 S2.1	S3.A S2.1	OFF to disable alarm ON to enable alarm

**Table 5.Q Enable/Disable Alarm**

**5.12.10 Alarm Delay Setpoint**

To determine how long a condition exists before an alarm activates, you must set the alarm delay. Both alarms have an independent alarm delay; however, the delay setting is common to all six alarm conditions.

The alarm delay times how long the condition is continuously above any active alarm threshold, and activates the alarm when the preset time is exceeded. The timer resets when the condition is below the alarm threshold. See Table 5.R for setting the alarm delays.

■ = OFF □ = ON

Alarm 1 (Set all 8 S2 switches)			Alarm 2			Delay
S3.8			S3.A			Time (seconds)
S2.2	S2.3	S2.4	S2.2	S2.3	S2.4	
off	off	off	off	off	off	1
on	off	off	on	off	off	2
off	on	off	off	on	off	3
on	on	off	on	on	off	4
off	off	on	off	off	on	5
on	off	on	on	off	on	10
off	on	on	off	on	on	15
on	on	on	on	on	on	20

**Table 5.R Alarm Delay Settings**

**5.12.11 Alarm Reset Delay Setpoint**

For the reset delay, the IQ DP-4000 determines how long the condition must be corrected before the corresponding alarm is reset. Both alarms have an independent reset delay; however, the delay setting is common to all six alarm conditions.

The reset delay measures how long the condition is continuously within the reset threshold, and clears the alarm only when the preset delay time is exceeded. The delay timer resets to zero when the condition is no longer within the alarm reset threshold. See Table 5.S to set the alarm reset delays.

■ = OFF □ = ON

Alarm 1 (Set all 8 S2 switches)			Alarm 2			Delay
S3.8			S3.A			Time (seconds)
S2.5	S2.6	S2.7	S2.5	S2.6	S2.7	
off	off	off	off	off	off	1
on	off	off	on	off	off	5
off	on	off	off	on	off	10
on	on	off	on	on	off	20
off	off	on	off	off	on	30
on	off	on	on	off	on	60
off	on	on	off	on	on	90
on	on	on	on	on	on	120

**Table 5.S Reset Delay Settings**

**5.12.12 Overvoltage Detection Level Alarm Setpoint**

This setpoint activates the alarm on an overvoltage condition (see Section 5.12.3). You must determine the overvoltage detection level. The overvoltage detection level is selected as a larger percentage of the nominal AC line voltage (see Section 5.5 p.23).

If the sampled voltage is greater than the overvoltage detection level for longer than the alarm delay (see 5.12.10 p.28), the enabled alarm activates. See Table 5.T for setting the overvoltage detection level.

■ = OFF □ = ON

Alarm 1 (Set all 8 S2 switches)			Alarm 2			Detection Level
S3.8	S3.9		S3.A	S3.B		%
S2.8	S2.1	S2.2	S2.8	S2.1	S2.2	
off	off	off	off	Off	off	105
on	off	off	on	off	off	110
off	on	off	off	on	off	115
on	on	off	on	on	off	120
off	off	on	off	off	on	125
on	off	on	on	off	on	130
off	on	on	off	on	on	135
on	on	on	on	on	on	140

**Table 5.T Overvoltage Detection Level Settings**

**5.12.13 Undervoltage Detection Level Setpoint**

The undervoltage detection level is a lower percentage of the nominal AC line voltage. When the alarm is set to activate on an undervoltage, you must determine the detection level. See Sections 5.5 (p.23) & 5.12.4 (p.27).

The alarm activates when the sampled voltage is less than the undervoltage detection level for longer than the alarm delay (see 5.12.10 p.28).

■ = OFF □ = ON

Alarm 1 (Set all 8 S2 switches)			Alarm 2			Detection Level
S3.9			S3.B			%
S2.3	S2.4	S2.5	S2.3	S2.4	S2.5	
off	off	off	off	off	off	60
on	off	off	on	off	off	65
off	on	off	off	on	off	70
on	on	off	on	on	off	75
off	off	on	off	off	on	80
on	off	on	on	off	on	85
off	on	on	off	on	on	90
on	on	on	on	on	on	95

**Table 5.U Undervoltage Detection Level Settings**

**5.12.14 Voltage Phase Unbalance Detection Level Alarm Setpoint**

If the selected alarm has been set to activate on a voltage phase unbalance (see 5.12.6 p.27), you must determine the voltage phase unbalance detection level. A voltage phase unbalance is calculated by taking the maximum voltage deviation between any two phases and comparing that voltage to a percentage of the nominal AC line voltage.

If the sampled voltage deviation is greater than the voltage phase unbalance detection level for longer than the alarm delay (see 5.12.10 p.28), the alarm activates. See Table 5.V for setting the voltage phase unbalance detection level.

■ = OFF □ = ON

Alarm 1 (Set all 8 S2 switches)			Alarm 2			Detection Level
S3.9			S3.B			%
S2.6	S2.7	S2.8	S2.6	S2.7	S2.8	
off	off	off	off	off	off	5
on	off	off	on	off	off	10
off	on	off	off	on	off	15
on	on	off	on	on	off	20
off	off	on	off	off	on	25
on	off	on	on	off	on	30
off	on	on	off	on	on	35
on	on	on	on	on	on	40

**Table 5.V Voltage Phase Unbalance Detection Level Settings**

**5.12.15 Alarm Reset Threshold Setpoint**

The IQ DP-4000 has three alarm conditions with programmable thresholds:

- overvoltage
- undervoltage
- voltage phase unbalance

You must set the levels for the IQ DP-4000 alarm to reset. Both alarms have an independent reset threshold; however, the reset threshold is common to all three alarm conditions.

The reset threshold is based on the detection levels set for the alarm conditions, as well as the nominal AC line voltage. The reset thresholds are described for each of the three programmable alarm conditions. See Table 5.W for setting the reset threshold.

■ = OFF □ = ON

Alarm 1 (Set all 8 S2 switches)			Alarm 2			Reset Level,
S3.C			S3.C			%
S2.1	S2.2	S2.3	S2.4	S2.5	S2.6	
off	off	off	off	off	off	0
on	off	off	on	off	off	10
off	on	off	off	on	off	20
on	on	off	on	on	off	30
off	off	on	off	off	on	40
on	off	on	on	off	on	50
off	on	on	off	on	on	75
on	on	on	on	on	on	100

**Table 5.W Reset Threshold Settings**

**5.12.15.1 Overvoltage Reset Threshold**

To determine the threshold level to reset the overvoltage, find the voltage when an overvoltage alarm will occur. This is the nominal AC line voltage (see Section 5.5) multiplied by the overvoltage detection level (see 5.12.12 p.29). Figure 5.1 (p.31) illustrates the overvoltage set and reset levels.

The reset voltage is a percentage of the difference (0 to 100%) between the nominal voltage and the overvoltage detection level, as determined by the reset threshold. You can calculate this by:

$$OVR = OVDL - RST \times (OVDL - NOM)$$

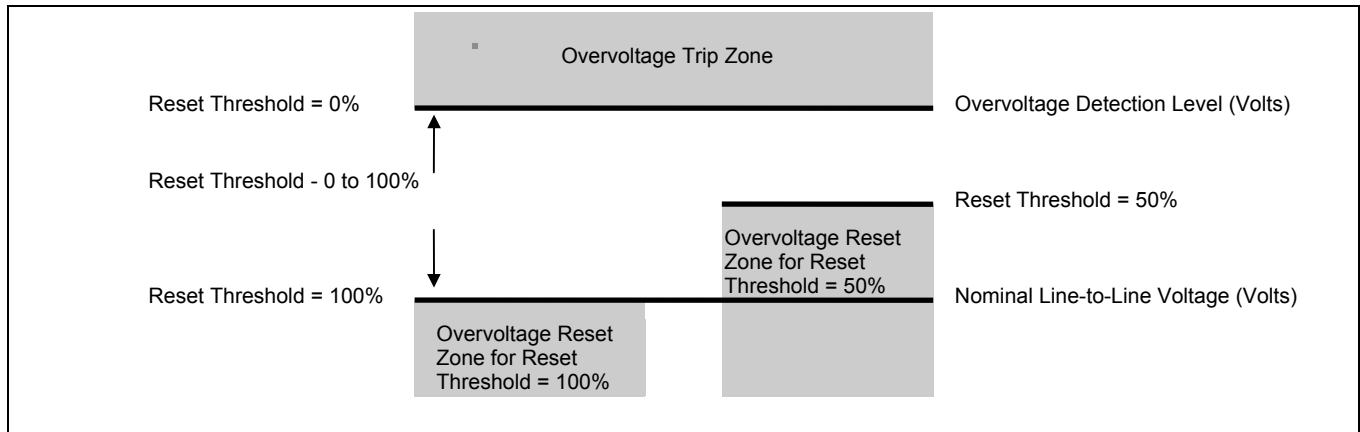
where

OVR = Overvoltage Reset (Volts)

RST = Reset Threshold

OVDL = Overvoltage Detection Level (Volts)

NOM = Nominal AC line Voltage (Volts)



**Figure 5.1 Overvoltage Detection and Reset Levels**

**Example 1**

A system has the following settings:

- Nominal AC Line Voltage = 208 V
- Overvoltage Detection Level = 125%
- Reset Threshold = 75%

For this system an overvoltage alarm will occur at:

$$208V \times 125\% = 260V$$

The overvoltage alarm will reset at:

$$\begin{aligned} &260V - 75\% \times (260V - 208V) \\ &= 260V - 75\% \times (52V) \\ &= 260V - 39V = 221V \end{aligned}$$

In this example, the overvoltage alarm will not reset until the system voltage is below 221V.

**Example 2**

A system has the following settings:

- Nominal AC Line Voltage = 480 V
- Overvoltage Detection Level = 110%

To determine the Reset Threshold setting for the overvoltage alarm to reset below 504 V:

The overvoltage alarm will occur at

$$480V \times 110\% = 528 V$$

$$504V = 528V - RST\% \times (528V - 480V)$$

$$504V = 528V - RST\% \times (48V)$$

$$RST\% \times (48V) = 528V - 504V = 24V$$

$$RST\% = 24V / 48V = 0.50$$

In this case, set the reset threshold to 50%

**5.12.15.2 Undervoltage Reset Threshold**

To determine where to reset an undervoltage alarm, find the voltage where the undervoltage alarm occurs. This voltage is the nominal AC line voltage (see Section 5.5 p.23) multiplied by the undervoltage detection level (see Section 5.12.13 p.29).

The reset voltage is a percentage of the difference (0 to 100%) between the nominal Voltage and the undervoltage detection level, as determined by the reset threshold. Compute this by:

$$UVR = UVDL + RST \times (NOM - UVDL)$$

where

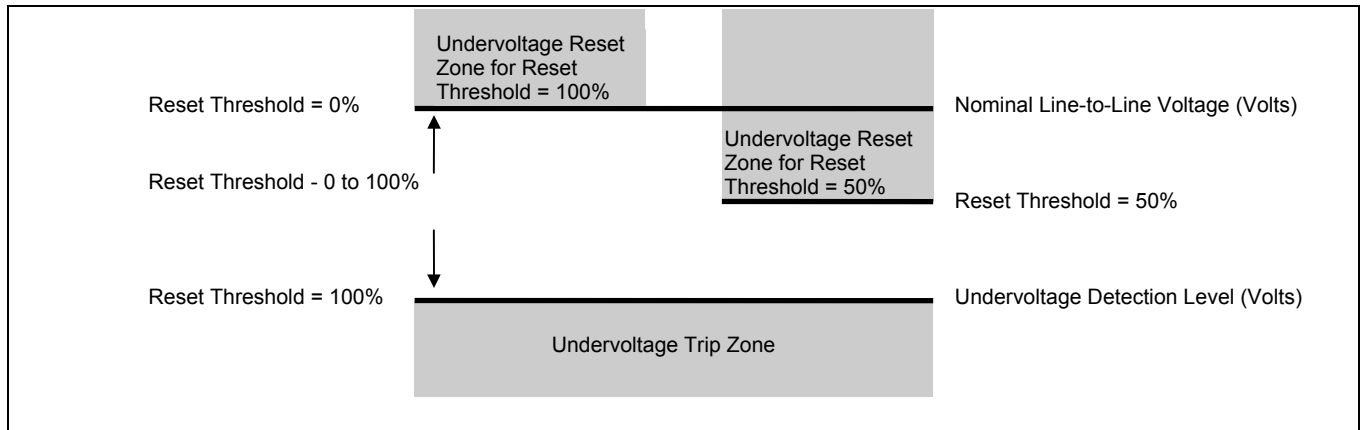
UVR = Undervoltage Reset (Volts)

UVDL = Undervoltage Detection Level (Volts)

RST = Reset Threshold

NOM = Nominal AC line Voltage (Volts)

On the following page, Figure 5.2 illustrates the undervoltage detection and reset levels.



**Figure 5.2 Undervoltage Detection and Reset Levels**

**Example 1**

A system has the following settings:

- Nominal AC Line Voltage = 208 V
- Undervoltage Detection Level = 80%
- Reset Threshold = 75%

For this system: An undervoltage alarm will occur at

$$208V \times 80\% = 166V$$

The undervoltage alarm will reset at

$$\begin{aligned} &166V + 75\% \times (208V - 166V) \\ &= 166V + 75\% \times (42V) \\ &= 166V + 32V = 198V \end{aligned}$$

In this example, the undervoltage alarm will not reset until the system voltage is above 198V.

**Example 2**

A system has the following settings:

- Nominal AC Line Voltage = 480 V
- Undervoltage Detection Level = 75%

Determine the reset threshold setting for the undervoltage alarm to reset above 420 V. The undervoltage alarm occurs at:

$$\begin{aligned} &480V \times 75\% = 360V \\ &420V = 360V + RST\% \times (480V - 360V) \end{aligned}$$

$$\begin{aligned} 420V &= 360V + RST\% \times (120V) \\ RST\% \times (120V) &= 420V - 360V = 60V \\ RST\% &= 60V / 120V = 0.50 \end{aligned}$$

In this case, set the reset threshold to 50% .

**5.12.15.3 Voltage Phase Unbalance Reset Threshold**

A voltage phase unbalance occurs when the maximum voltage deviation between two phases is greater than a percentage of the nominal AC line voltage. To find the voltage level, calculate where a voltage phase unbalance alarm will occur. To do this, multiply the nominal AC line voltage (see Section 5.5 p.23) by the voltage phase unbalance detection level (see Section 5.12.14 p.29).

The reset voltage is a percentage of the difference (100 to 0%) between zero volts (all of the phases being equal in voltage) and the voltage phase unbalance detection level, as determined by the reset threshold. Compute this by:

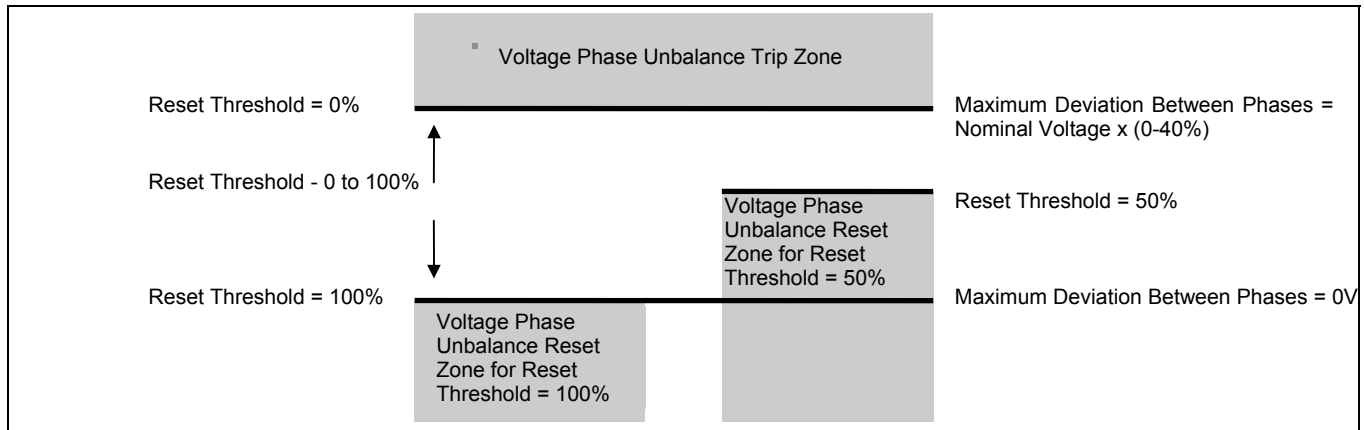
$$VPU = MVD - MVD \times RST$$

where

- VPU = Voltage Phase Unbalance Reset (Volts)
- MVD = Maximum Voltage Deviation where a Phase Unbalance Alarm occurs (Volts)
- RST = Reset Threshold

On the following page, Figure 5.3 illustrates the voltage phase unbalance detection and reset levels.





**Figure 5.3 Voltage Phase Unbalance Detection and Reset Levels**

**Example 1**

A system has the following settings:

Nominal AC Line Voltage = 208 V

Voltage Phase Unbalance Detection Level = 15%

Reset Threshold = 75%

For this system a voltage phase unbalance alarm occurs when any 2 phases have a voltage difference greater than:

$$208V \times 15\% = 31V$$

The voltage phase unbalance alarm resets when all 3 phases are within:

$$31V - (31V \times 75\%) = 8V \text{ of each other}$$

**Example 2**

A system has the following settings:

Nominal AC Line Voltage = 480 V

Voltage Phase Unbalance Detection Level = 25%

Determine the reset threshold setting for the voltage phase unbalance alarm to reset when all 3 phases of voltage are within 84V of each other: The voltage phase unbalance alarm will occur when any 2 phases have a voltage difference greater than:

$$480V \times 25\% = 120V$$

$$84V = 120V - 120V \times RST$$

$$120V \times RST = 120V - 84V$$

$$120V \times RST = 36V$$

$$RST = 36V / 120V = 0.3$$

In this case, set the reset threshold to 30% .

### **5.13 POWERNET PROGRAMMABLE SETPOINT**

You can allow programming of the IQ DP-4000 using PowerNet / IMPACC with this setpoint. You must enable this setpoint in order to download information to the IQ DP-4000 from Cutler Hammer's PowerNet software. Record the desired setting of Switch **S2.7** for Rotary Select Switch position **S3.C** as follows: **(You must set all 8 S2 switches; otherwise, communication mode and alarm thresholds will be overwritten)**

- OFF position to disable programming of the DP-4000 via PowerNet / IMPACC
- ON position to enable programming of the DP-4000 via PowerNet / IMPACC

If disabled, the DP-4000 will continue to communicate over PowerNet / IMPACC, although you cannot change the setpoints remotely.

### **5.14 DP-4000 / DP-2 MODE SETPOINT**

This setpoint allows the DP-4000 to communicate over PowerNet / IMPACC either as a DP-4000 or as a Data Plus II (DP2). This setpoint affects communications only. It does not affect the operation of the unit. This allows DP-4000 compatibility with older, existing systems. Record the desired setting of Switch **S2.8** for Rotary Select Switch position **S3.C** as follows: **(You must set all 8 S2 switches)**

- OFF position to communicate as a Data Plus II
- ON position to communicate as a DP-4000

### **5.15 OPTIONAL I/O SETPOINTS**

These setpoints are relevant only if the IQ DP-4000 is equipped with the optional I/O module.

#### **5.15.1 Discrete Input Setup Setpoint**

*Note: This setpoint is relevant only if the IQ DP-4000 is equipped with the optional I/O module.*

The discrete input is configured to either a sync or a reset input. Record the desired setting of Switch **S2.7** for Rotary Select Switch position **S3.5** as follows: **(You must set all 8 S2 switches)**

- OFF position to function as a sync pulse
- ON position to have the discrete input function as a reset input

If the discrete input is set up as a sync pulse input, a dry contact closure across the terminal blocks of the discrete input will cause the start of a new demand window. The sync window time can be variable or fixed, determined by setting the sync pulse setpoint (see 5.15.3 p.34).

If the discrete input is set up as a reset input, a dry contact closure across the terminal blocks of the discrete input will attempt to reset an active alarm. (This is identical to using the Reset pushbutton when resetting an alarm.)

#### **5.15.2 Sync Pulse Setpoint**

*Note: This setpoint is relevant only if the IQ DP-4000 is equipped with the optional I/O module.*

The IQ DP-4000 is designed to calculate the demand either by an internal synchronizing timer or by an external signal.

Record the desired setting of Setpoint Switch **S2.8** for Rotary Select Switch position **S3.5** as follows:

- OFF to calculate demand based on an external signal (see Section 5.15.1 p.34 - Discrete Input Setup)
- ON to calculate demand based on a pre-programmed time(see Section 5.9 p.24 - Demand Parameters)

#### **5.15.3 Pulse Initiator/Load Shed Setpoint**

The IQ DP-4000 has a relay which can be programmed based on the amount of power and energy measured. The pulse initiator function tracks the amount of energy measured and the load shed function changes the state of a relay when a predetermined power threshold is exceeded.

Record the desired setting of Setpoint Switch **S2.1** for Rotary Select Switch position **S3.D** as follows:

- OFF to use relay for the pulse initiator function (see paragraph 5.15.3.1, p.34)
- ON to use relay for the load shed function (see paragraph 5.15.3.4, p.38)

##### **5.15.3.1 Pulse Initiator Settings, Parameter Selection**

The pulse initiator changes the state of the pulse initiator relay at a rate proportional to the amount of energy the IQ DP-4000 measures, based on a user-selected energy parameter and pulse rate. Select one of the following parameters to track with the pulse initiator:

- Watt-hours (positive or negative)
- Var-hours (positive or negative)
- VA-hours

See Table 5.X for selecting the energy parameter.

■ = OFF □ = ON

Energy Parameter	S3.D Settings (Set all 8 S2 switches)		
	S2.2	S2.3	S2.4
Positive Watt-hours	on	off	off
Negative Watt-hours	off	on	off
Positive Var-hours	on	on	off
Negative Var-hours	off	off	on
VA-hours	on	off	on
Invalid	Any Other Selection		

**Table 5.X Pulse Initiator Parameter Selection Settings**

*5.15.3.2 Load Shed Settings, Range Selection*

Two ranges are associated with the load shed feature: a Load Shed range and a Restore Load range. Both ranges are set as a percentage of the nominal values for the system. When the Load Shed range is exceeded, the relay activates. This relay remains active until the value of the selected parameter drops below the Restore Load range.

The nominal system voltage is explained in Section 5.5 (p.23).

The nominal system current is the value selected for the CT primary in Section 5.7 (p.24).

The nominal system power is the product of the nominal system voltage and nominal system current. See Table 5.Y for setting the load shed and restore load ranges.

■ = OFF    □ = ON

Ranges		Switch Settings (Set all 8 S2 switches)					
Load Shed, % of nominal	Rotary Switch	S3.E				S3.D	
	Setpoint Switch	S2.1	S2.2	S2.3	S2.4	S2.5	S2.6
Restore Load, % of nominal	Rotary Switch	S3.E				S3.D	
	Setpoint Switch	S2.5	S2.6	S2.7	S2.8	S2.7	S2.8
10		off	off	off	off	off	off
12		on	off	off	off	off	off
14		off	on	off	off	off	off
16		on	on	off	off	off	off
18		off	off	on	off	off	off
20		on	off	on	off	off	off
22		off	on	on	off	off	off
24		on	on	on	off	off	off
26		off	off	off	on	off	off
28		on	off	off	on	off	off
30		off	on	off	on	off	off
32		on	on	off	on	off	off
34		off	off	on	on	off	off
36		on	off	on	on	off	off
38		off	on	on	on	off	off
40		on	on	on	on	off	off
42		off	off	off	off	on	off
44		on	off	off	off	on	off
46		off	on	off	off	on	off
48		on	on	off	off	on	off
50		off	off	on	off	on	off
52		on	off	on	off	on	off
54		off	on	on	off	on	off
56		on	on	on	off	on	off
58		off	off	off	on	on	off
60		on	off	off	on	on	off
62		off	on	off	on	on	off
64		on	on	off	on	on	off
66		off	off	on	on	on	off
68		on	off	on	on	on	off
70		off	on	on	on	on	off
72		on	on	on	on	on	off
74		off	off	off	off	off	on
76		on	off	off	off	off	on
78		off	on	off	off	off	on
80		on	on	off	off	off	on
82		off	off	on	off	off	on

**Table 5.Y Load Shed and Restore Load Settings (continued on next page)**

■ = OFF    □ = ON

Ranges		Switch Settings (Set all 8 S2 switches)					
Load Shed, % of nominal	Rotary Switch	S3.E				S3.D	
	Setpoint Switch	S2.1	S2.2	S2.3	S2.4	S2.5	S2.6
Restore Load, % of nominal	Rotary Switch	S3.E				S3.D	
	Setpoint Switch	S2.5	S2.6	S2.7	S2.8	S2.7	S2.8
84		on	off	on	off	off	on
86		off	on	on	off	off	on
88		on	on	on	off	off	on
90		off	off	off	on	off	on
92		on	off	off	on	off	on
94		off	on	off	on	off	on
96		on	on	off	on	off	on
98		off	off	on	on	off	on
100		on	off	on	on	off	on
102		off	on	on	on	off	on
104		on	on	on	on	off	on
106		off	off	off	off	on	on
108		on	off	off	off	on	on
110		off	on	off	off	on	on
112		on	on	off	off	on	on
114		off	off	on	off	on	on
116		on	off	on	off	on	on
118		off	on	on	off	on	on
120		on	on	on	off	on	on
122		off	off	off	on	on	on
124		on	off	off	on	on	on
126		off	on	off	on	on	on
128		on	on	off	on	on	on
130		off	off	on	on	on	on
132		on	off	on	on	on	on
134		off	on	on	on	on	on
136		on	on	on	on	on	on

**Table 5.Y Load Shed and Restore Load Settings**

CT = 1400:5

PT = 240:120

**5.15.3.3 Load Shed Settings, Parameter Selection**

The load shed feature activates the pulse initiator relay when a user-selected parameter exceeds a preprogrammed range (see 5.15.3.2 p.35). Select one of the following parameters to monitor:

- Watts - Metered or Demand
- VA - Metered or Demand
- Metered Currents - I<sub>A</sub>, I<sub>B</sub>, I<sub>C</sub>, or average
- Demand Currents- I<sub>A</sub>, I<sub>B</sub>, I<sub>C</sub>, or average

See Table 5.Z for selecting the parameter to monitor with the load shed feature.

■ = OFF □ = ON

Parameter	S3.F Settings (Set all 8 S2 switches)			
	S2.1	S2.2	S2.3	S2.4
Watts, metered	off	off	off	off
Watts, demand	on	off	off	off
VA, metered	off	on	off	off
VA, demand	on	on	off	off
I <sub>A</sub> Current, metered	off	off	on	off
I <sub>B</sub> Current, metered	on	off	on	off
I <sub>C</sub> Current, metered	off	on	on	off
Ave. Current, metered	on	on	on	off
I <sub>A</sub> Current, demand	off	off	off	on
I <sub>B</sub> Current, demand	on	off	off	on
I <sub>C</sub> Current, demand	off	on	off	on
Ave. Current, demand	on	on	off	on
Invalid	Any other selection			

**Table 5.Z Load Shed Parameter Selection Settings**

**5.15.3.4 Pulse Initiator Settings, Rate Selection**

For this function, select the rate at which the relay changes state as a value of energy to track with the pulse initiator. For example, if you choose Watt-hours as the parameter to track with the pulse initiator, the IQ DP-4000 will change the state of the relay at every specified interval of Watt-hours. If 50 Watt-hours per Pulse is selected, the relay changes state every time 50 Watt-hours accumulate.

The energy per pulse corresponds to the energy (in units), at the **secondary** winding of the PTs and CTs. Therefore, you must consider the user-selected CT and PT ratios when selecting the Energy per Pulse value. See Table 5.AA for selecting the rate at which the pulse initiator relay changes state.

Example: A system has the following configuration:

The IQ DP-4000 is monitoring a constant power of 16,800 Watts.

Watt-hours is selected as the parameter for the pulse initiator setting.

The CT ratio is 1400 / 5 = 280

The PT ratio is 240 / 120 = 2

The power at the secondary of the CTs and PTs is:

$$16,800 \text{ Watts} / 280 \times 2 =$$

$$16,800 \text{ Watts} / 560 =$$

$$30 \text{ Watts (or 30 Watt-hours in 1 hour)}$$

- If the energy per pulse is set to 1, each pulse will equal 560 Watt-hours.

$$1400 \times 240 \times 1 = 560 \text{ Watt-hours per pulse.}$$

$$5 \quad 120$$

- If the energy per pulse is set to 7, each pulse will equal 3,920 Watt-hours.

$$1400 \times 240 \times 7 = 3920 \text{ Watt-hours per pulse.}$$

$$5 \quad 120$$

■ = OFF □ = ON

Energy per Pulse	S3.F Settings (Set all 8 S2 switches)			
	S2.5	S2.6	S2.7	S2.8
1	off	off	off	off
2	on	off	off	off
3	off	on	off	off
4	on	on	off	off
5	off	off	on	off
6	on	off	on	off
7	off	on	on	off
8	on	on	on	off
9	off	off	off	on
10	on	off	off	on
20	off	on	off	on
40	on	on	off	on
50	off	off	on	on
60	on	off	on	on
80	off	on	on	on
100	on	on	on	on

**Table 5.AA Pulse Initiator Rate Selection Settings**

### **6.1 LEVEL OF REPAIR**

This manual is written assuming you will perform only unit-level troubleshooting. If you trace the cause of a malfunction to the IQ DP-4000, replace the unit with a spare and return the malfunctioning unit to Cutler-Hammer for factory repairs.

### **6.2 MAINTENANCE AND CARE**

The IQ DP-4000 is designed to be a self-contained and maintenance-free unit. The printed circuit boards are calibrated and conformal coated at the factory. They are intended for service by factory trained personnel only.

Operate the IQ DP-4000 in an environment within the temperature range of -25°C to +70°C. The environment should also be free of excess humidity.

If you have spare units, store them in the original packing material and container.

### **6.3 TROUBLESHOOTING**

This section divides troubleshooting into two parts:

- Troubleshooting during initial startup (refer to Table 6.A, p.40)
- Troubleshooting during operation (refer to Table 6.B, p.41)

---

 **WARNING**

---

**ALL MAINTENANCE PROCEDURES MUST BE PERFORMED ONLY BY QUALIFIED PERSONNEL WHO ARE FAMILIAR WITH THE IQ DP-4000 AND ITS USES. FAILURE TO OBSERVE THIS WARNING COULD RESULT IN SERIOUS INJURY, DEATH, AND/OR EQUIPMENT DAMAGE.**

**TROUBLESHOOTING PROCEDURES MAY INVOLVE WORKING ON EQUIPMENT IN AREAS WITH EXPOSED LIVE PARTS WHERE THE HAZARD OF A FATAL ELECTRIC SHOCK IS PRESENT. PERSONNEL MUST EXERCISE EXTREME CAUTION TO AVOID INJURY OR EVEN DEATH.**

**ALWAYS DISCONNECT AND LOCK OUT THE CURRENT SOURCE AND CONTROL POWER SUPPLY BEFORE TOUCHING THE COMPONENTS ON THE REAR OF THE IQ DP-4000.**

### **6.4 REPLACEMENT**

To replace the IQ DP-4000:

1. Turn off control power at the main disconnect or isolation switch of the power supply. If the switch is not located in view of the IQ DP-4000, lock it out to guard against other personnel accidentally turning on the switch.
2. Verify that all “foreign” power sources wired to the IQ DP-4000 are de-energized. These sources may also be present on the relay and the input/output terminal block. Temporarily short the current transformer (CT) inputs at a point prior to the IQ DP-4000’s terminals before attempting to open the terminals on the IQ DP-4000.
3. Before disconnecting any wires from the unit, you must individually identify them to assure that you can reconnect them properly. Make a sketch to aid in terminal and wire identification.
4. If an optional ribbon cable connects with the communication port, carefully disconnect it.
5. If the power module for the unit is in a remote location, carefully unplug the optional extension cable from the IQ DP-4000 chassis, not from the power module. Remove the wires by loosening the wire connection at the screw terminal.

---

 **WARNING**

---

**SUPPORT THE IQ DP-4000 FROM THE FRONT SIDE WHEN THE SCREWS ARE LOOSENED OR REMOVED IN STEP 6. WITHOUT SUCH SUPPORT, THE UNIT COULD FALL OR THE PANEL COULD BE DAMAGED.**

6. Remove the mounting screws holding the unit against the door or panel. The screws are accessible from the rear of the unit. Carefully lay the screws aside for later use.
7. Remove the present unit and mount the replacement unit according to 4.2.2 (p.12). Do not over-tighten screws.
8. To connect the replacement unit, reverse the procedure outlined in steps 4 - 7.
9. Use the sketch you made in step 3 to replace each wire at the correct terminal.
10. Go to Section 4.5 (p.20) and perform initial startup.

**6.5 TECHNICAL ASSISTANCE**

For information, technical assistance, or referral to an authorized distributor, contact Cutler-Hammer Power Management Applications Support (PMAS) at 1-800-809-2772.

Symptom	Probable Cause(s)	Solution
All Operator Panel indicators are off.	Supply voltage level is deficient.	Measure the supply voltage and locate the cause of the deficiency.
	Control power is deficient (only if using separate source or dc source power modules).	Locate the cause of the deficiency in the control power line. If power is sufficient, replace unit.
	AC line, or optional, external PTs are not properly selected, wired, or installed.	Verify that the AC line and/or PTs are wired as shown on the wiring plan drawings for the application.
Both voltage and current readings are incorrect and unstable.	The case is not grounded	Attach ground wire to either the power module or DP4000 ground terminal.
Digit 1 flashes in the display window, indicating an external trip.	A trip condition has been externally initiated through the Communications Port.	Determine why the trip was initiated from the external device through the Communications Option.
Digit 2 flashes in the display window indicating an overvoltage	AC line, or optional, external PTs are not properly installed or wired.	Verify that the AC line, and PTs are installed and wired as shown on the wiring plan drawing for the application.
Digit 3 flashes in the display window, indicating an undervoltage.	An Undervoltage condition actually exists.	Isolate the AC line deficiency's cause.
Digit 4 flashes in the display window, indicating a phase unbalance.	A Phase Unbalance condition exists.	Isolate the cause of the AC line deficiency.
Digit 5 flashes in the display window, indicating a voltage phase loss.	A Voltage Phase Loss condition exists.	Isolate the cause of the AC line phase cause.
	Blown or loose fuse(s).	Check the fuse(s) on the affected phase(s). Reseat fuse(s). Replace if necessary.
Digit 6 flashes in the display window, indicating a current phase loss.	A Current Phase Loss condition exists.	Correct the improper wiring.
Digit 7 flashes in display window, indicating a phase reversal.	A Phase Reversal condition exists.	Isolate the cause of the AC line reversal. Check the utility to determine their phase sequence.
Digit 8 flashes in display window, indicating an internal malfunction.	IQ DP-4000 is detecting an internal malfunction or data is out of range.	Cycle Power. If the problem persists, replace the unit.
One or more voltage phases read incorrectly.	Blown or loose fuse(s).	Check fuse(s) on the affected phase(s). Reseat the fuse(s). Replace if necessary.
	Incorrect PT ratio.	Check PT ratio.
Current readings are not accurate or read zero.	Incorrect size CTs used.	Replace with proper size CTs.
	Incorrect CT ratio.	Check CT ratio.
Power readings are incorrect.	Phasing for voltage and current is incorrect.	Check phasing. Verify connections with wiring diagrams.

**Table 6.A Initial Power-On Troubleshooting**



<b>Symptom</b>	<b>Probable Cause(s)</b>	<b>Solution</b>
All Operator Panel LEDs are off.	AC line being monitored is below 96 VAC.	Locate the cause of the deficiency in the monitored AC line.
	Separate Source AC line voltage is deficient.	Locate the cause of the deficiency in the AC control power line.
	AC line fuses are blown, missing, or not contacting correctly.	Verify that the incoming AC line is at the correct voltage level. Check that the fuses are sitting correctly in their clips.
	IQ DP-4000 is malfunctioning.	Replace the unit.
Digit 1 flashes in the display window.	A trip condition has been externally initiated through the Communications Port.	Determine why the trip was initiated from the external device through the Communications Port.
Digit 2 flashes in the display window.	An overvoltage condition is detected.	Isolate the cause in the line.
Digit 3 flashes in the display window.	An undervoltage condition is detected.	Isolate the cause in the line.
Digit 4 flashes in the display window.	A phase unbalance condition is detected.	Isolate the cause in the line.
Digit 5 flashes in the display window.	A voltage phase loss condition is detected.	Isolate the cause in the line.
	Blown or loose fuse(s).	Check fuse(s) on affected phase(s). Reseat the fuse(s). Replace the fuse(s) if necessary.
Digit 6 flashes in the display window.	A current phase loss condition is detected.	Isolate the cause of the AC current phase loss.
Digit 7 flashes in the display window.	The IQ DP-4000 is detecting a phase reversal.	Isolate the cause of the AC line phase reversal.
Digit 8 flashes in the display window.	The IQ DP-4000 is detecting an internal malfunction.	Replace the unit.
One or more voltage phases read incorrectly	Blown or loose fuse(s).	Check fuse(s) on affected phase(s). Reseat the fuse(s). Replace the fuse(s) if necessary.
	Incorrect PT ratio.	Check PT ratio.
Current readings are not accurate or read zero.	Incorrect size CTs used.	Replace with proper size CTs.
	Incorrect CT ratio.	Check CT ratio.
Power readings are incorrect.	Phasing for voltage and current is incorrect.	Check phasing. Verify connections with wiring diagrams.

**Table 6.B Operational Troubleshooting**

**6.6 RETURN PROCEDURE**

The troubleshooting section is intended for service personnel to identify whether an observed problem is external or internal to the unit. For assistance with this determination, please contact Power Management Applications Support (PMAS) at 1-800-809-2772. If a problem is identified as internal, return the unit to the factory for repair or replacement. To return your unit, contact your local Cutler-Hammer authorized distributor.

■ = OFF    □ = ON

PT		Switch Setting								
Values		Pressing & Holding S1 causes all 8 switches on S2 to be saved according to the Rotary Switch S3. Always set all 8 S2 switches. See Figure 2.2 (p.4) and Table 5.A (p.21).								
PT Ratio (PT:1)	Rotary Switch	S3.1	S3.2							
	Setpoint Switch	S2.7	S2.1	S2.2	S2.3	S2.4	S2.5	S2.6	S2.7	S2.8
1		off	off	off	off	off	off	off	off	off
1.1		off	on	off	off	off	off	off	off	off
1.2		off	off	on	off	off	off	off	off	off
1.3		off	on	on	off	off	off	off	off	off
1.4		off	off	off	on	off	off	off	off	off
1.5		off		off	on	off	off	off	off	off
1.6		off	off	on	on	off	off	off	off	off
1.7		off	on	on	on	off	off	off	off	off
1.8		off	off	off	off	on	off	off	off	off
1.9		off	on	off	off	on	off	off	off	off
2		off	off	on	off	on	off	off	off	off
2.1		off	on	on	off	on	off	off	off	off
2.2		off	off	off	on	on	off	off	off	off
2.3		off	on	off	on	on	off	off	off	off
2.4		off	off	on	on	on	off	off	off	off
2.5		off	on	on	on	on	off	off	off	off
2.6		off	off	off	off	off	on	off	off	off
2.7		off	on	off	off	off	on	off	off	off
2.8		off	off	on	off	off	on	off	off	off
2.9		off	on	on	off	off	on	off	off	off
3.0		off	off	off	on	off	on	off	off	off
3.1		off	on	off	on	off	on	off	off	off
3.2		off	off	on	on	off	on	off	off	off
3.3		off	on	on	on	off	on	off	off	off
3.4		off	off	off	off	on	on	off	off	off
3.5		off	on	off	off	on	on	off	off	off
3.6		off	off	on	off	on	on	off	off	off
3.7		off	on	on	off	on	on	off	off	off
3.8		off	off	off	on	on	on	off	off	off
3.9		off	on	off	on	on	on	off	off	off
4.0		off	off	on	on	on	on	off	off	off
4.1		off	on	on	on	on	on	off	off	off
4.2		off	off	off	off	off	off	on	off	off
4.3		off	on	off	off	off	off	on	off	off
4.4		off	off	on	off	off	off	on	off	off
4.5		off	on	on	off	off	off	on	off	off

■ = OFF      □ = ON

PT		Switch Settings								
Values	Pressing & Holding S1 causes all 8 switches on S2 to be saved according to the Rotary Switch S3. Always set all 8 S2 switches. See Figure 2.2 (p.4) and Table 5.A (p.21).									
PT Ratio (PT:1)	Rotary Switch	S3.1	S3.2							
	Setpoint Switch	S2.7	S2.1	S2.2	S2.3	S2.4	S2.5	S2.6	S2.7	S2.8
4.6		off	off	off	on	off	off	on	off	off
4.7		off	on	off	on	off	off	on	off	off
4.8		off	off	on	on	off	off	on	off	off
4.9		off	on	on	on	off	off	on	off	off
5.0		off	off	off	off	on	off	on	off	off
5.1		off	on	off	off	on	off	on	off	off
5.2		off	off	on	off	on	off	on	off	off
5.3		off	on	on	off	on	off	on	off	off
5.4		off	off	off	on	on	off	on	off	off
5.5		off	on	off	on	on	off	on	off	off
5.6		off	off	on	on	on	off	on	off	off
5.7		off	on	on	on	on	off	on	off	off
5.8		off	off	off	off	off	on	on	off	off
5.9		off	on	off	off	off	on	on	off	off
6		off	off	on	off	off	on	on	off	off
7		off	on	on	off	off	on	on	off	off
8		off	off	off	on	off	on	on	off	off
9		off	on	off	on	off	on	on	off	off
10		off	off	on	on	off	on	on	off	off
11		off	on	on	on	off	on	on	off	off
12		off	off	off	off	on	on	on	off	off
13		off	on	off	off	on	on	on	off	off
14		off	off	on	off	on	on	on	off	off
15		off	on	on	off	on	on	on	off	off
16		off	off	off	on	on	on	on	off	off
17		off	on	off	on	on	on	on	off	off
18		off	off	on	on	on	on	on	off	off
19		off	on	on	on	on	on	on	off	off
20		off	off	off	off	off	off	off	on	off
25		off	on	off	off	off	off	off	on	off
30		off	off	on	off	off	off	off	on	off
35		off	on	on	off	off	off	off	on	off
40		off	off	off	on	off	off	off	on	off
45		off	on	off	on	off	off	off	on	off
50		off	off	on	on	off	off	off	on	off
55		off	on	on	on	off	off	off	on	off
60		off	off	off	off	on	off	off	on	off

■ = OFF      □ = ON

PT		Switch Settings								
Values	Pressing & Holding S1 causes all 8 switches on S2 to be saved according to the Rotary Switch S3. Always set all 8 S2 switches. See Figure 2.2 (p.4) and Table 5.A (p.21).									
PT Ratio (PT:1)	Rotary Switch	S3.1	S3.2							
	Setpoint Switch	S2.7	S2.1	S2.2	S2.3	S2.4	S2.5	S2.6	S2.7	S2.8
65		off	on	off	off	on	off	off	on	off
70		off	off	on	off	on	off	off	on	off
75		off	on	on	off	on	off	off	on	off
80		off	off	off	on	on	off	off	on	off
85		off	on	off	on	on	off	off	on	off
90		off	off	on	on	on	off	off	on	off
95		off	on	on	on	on	off	off	on	off
100		off	off	off	off	off	on	off	on	off
105		off	on	off	off	off	on	off	on	off
110		off	off	on	off	off	on	off	on	off
115		off	on	on	off	off	on	off	on	off
120		off	off	off	on	off	on	off	on	off
125		off	on	off	on	off	on	off	on	off
130		off	off	on	on	off	on	off	on	off
135		off	on	on	on	off	on	off	on	off
140		off	off	off	off	on	on	off	on	off
145		off	on	off	off	on	on	off	on	off
150		off	off	on	off	on	on	off	on	off
155		off	on	on	off	on	on	off	on	off
160		off	off	off	on	on	on	off	on	off
165		off	on	off	on	on	on	off	on	off
170		off	off	on	on	on	on	off	on	off
175		off	on	on	on	on	on	off	on	off
180		off	off	off	off	off	off	on	on	off
185		off	on	off	off	off	off	on	on	off
190		off	off	on	off	off	off	on	on	off
195		off	on	on	off	off	off	on	on	off
200		off	off	off	on	off	off	on	on	off
205		off	on	off	on	off	off	on	on	off
210		off	off	on	on	off	off	on	on	off
215		off	on	on	on	off	off	on	on	off
220		off	off	off	off	on	off	on	on	off
225		off	on	off	off	on	off	on	on	off
230		off	off	on	off	on	off	on	on	off
235		off	on	on	off	on	off	on	on	off
240		off	off	off	on	on	off	on	on	off
245		off	on	off	on	on	off	on	on	off
250		off	off	on	on	on	off	on	on	off
255		off	on	on	on	on	off	on	on	off
260		off	off	off	off	off	on	on	on	off

■ = OFF      □ = ON

PT		Switch Settings								
Values	Pressing & Holding S1 causes all 8 switches on S2 to be saved according to the Rotary Switch S3. Always set all 8 S2 switches. See Figure 2.2 (p.4) and Table 5.A (p.21).									
PT Ratio (PT:1)	Rotary Switch	S3.1	S3.2							
	Setpoint Switch	S2.7	S2.1	S2.2	S2.3	S2.4	S2.5	S2.6	S2.7	S2.8
270		off	on	off	off	off	on	on	on	off
280		off	off	on	off	off	on	on	on	off
290		off	on	on	off	off	on	on	on	off
300		off	off	off	on	off	on	on	on	off
310		off	on	off	on	off	on	on	on	off
320		off	off	on	on	off	on	on	on	off
330		off	on	on	on	off	on	on	on	off
340		off	off	off	off	on	on	on	on	off
350		off	on	off	off	on	on	on	on	off
360		off	off	on	off	on	on	on	on	off
370		off	on	on	off	on	on	on	on	off
380		off	off	off	on	on	on	on	on	off
390		off	on	off	on	on	on	on	on	off
400		off	off	on	on	on	on	on	on	off
410		off	on	on	on	on	on	on	on	off
420		off	off	off	off	off	off	off	off	on
430		off	on	off	off	off	off	off	off	on
440		off	off	on	off	off	off	off	off	on
450		off	on	on	off	off	off	off	off	on
460		off	off	off	on	off	off	off	off	on
470		off	on	off	on	off	off	off	off	on
480		off	off	on	on	off	off	off	off	on
490		off	on	on	on	off	off	off	off	on
500		off	off	off	off	on	off	off	off	on
510		off	on	off	off	on	off	off	off	on
520		off	off	on	off	on	off	off	off	on
530		off	on	on	off	on	off	off	off	on
540		off	off	off	on	on	off	off	off	on
550		off	on	off	on	on	off	off	off	on
560		off	off	on	on	on	off	off	off	on
570		off	on	on	on	on	off	off	off	on
580		off	off	off	off	off	on	off	off	on
590		off	on	off	off	off	on	off	off	on
600		off	off	on	off	off	on	off	off	on
610		off	on	on	off	off	on	off	off	on
620		off	off	off	on	off	on	off	off	on
630		off	on	off	on	off	on	off	off	on
640		off	off	on	on	off	on	off	off	on

■ = OFF      □ = ON

PT		Switch Settings								
Values		Pressing & Holding S1 causes all 8 switches on S2 to be saved according to the Rotary Switch S3. Always set all 8 S2 switches. See Figure 2.2 (p.4) and Table 5.A (p.21).								
PT Ratio (PT:1)	Rotary Switch	S3.1	S3.2							
	Setpoint Switch	S2.7	S2.1	S2.2	S2.3	S2.4	S2.5	S2.6	S2.7	S2.8
650		off	on	on	on	off	on	off	off	on
660		off	off	off	off	on	on	off	off	on
670		off	on	off	off	on	on	off	off	on
680		off	off	on	off	on	on	off	off	on
690		off	on	on	off	on	on	off	off	on
700		off	off	off	on	on	on	off	off	on
710		off	on	off	on	on	on	off	off	on
720		off	off	on	on	on	on	off	off	on
730		off	on	on	on	on	on	off	off	on
740		off	off		off	off	off	on	off	on
750		off	on	off	off	off	off	on	off	on
760		off	off	on	off	off	off	on	off	on
770		off	on	on	off	off	off	on	off	on
780		off	off	off	on	off	off	on	off	on
790		off	on	off	on	off	off	on	off	on
800		off	off	on	on	off	off	on	off	on
810		off	on	on	on	off	off	on	off	on
820		off	off	off	off	on	off	on	off	on
830		off	on	off	off	on	off	on	off	on
840		off	off	on	off	on	off	on	off	on
850		off	on	on	off	on	off	on	off	on
860		off	off	off	on	on	off	on	off	on
870		off	on	off	on	on	off	on	off	on
880		off	off	on	on	on	off	on	off	on
890		off	on	on	on	on	off	on	off	on
900		off	off	off	off	off	on	on	off	on
910		off	on	off	off	off	on	on	off	on
920		off	off	on	off	off	on	on	off	on
930		off	on	on	off	off	on	on	off	on
940		off	off	off	on	off	on	on	off	on
950		off	on	off	on	off	on	on	off	on
960		off	off	on	on	off	on	on	off	on
970		off	on	on	on	off	on	on	off	on
980		off	off	off	off	on	on	on	off	on
990		off	on	off	off	on	on	on	off	on
1000		off	off	on	off	on	on	on	off	on
1010		off	on	on	off	on	on	on	off	on
1020		off	off	off	on	on	on	on	off	on

■ = OFF      □ = ON

PT		Switch Settings								
Values	Pressing & Holding S1 causes all 8 switches on S2 to be saved according to the Rotary Switch S3. Always set all 8 S2 switches. See Figure 2.2 (p.4) and Table 5.A (p.21).									
PT Ratio (PT:1)	Rotary Switch	S3.1	S3.2							
	Setpoint Switch	S2.7	S2.1	S2.2	S2.3	S2.4	S2.5	S2.6	S2.7	S2.8
1030		off	on	off	on	on	on	on	off	on
1040		off	off	on	on	on	on	on	off	on
1050		off	on	on	on	on	on	on	off	on
1060		off	off	off	off	off	off	off	on	on
1070		off	on	off	off	off	off	off	on	on
1080		off	off	on	off	off	off	off	on	on
1090		off	on	on	off	off	off	off	on	on
1100		off	off	off	on	off	off	off	on	on
1110		off	on	off	on	off	off	off	on	on
1120		off	off	on	on	off	off	off	on	on
1130		off	on	on	on	off	off	off	on	on
1140		off	off	off	off	on	off	off	on	on
1150		off	on	off	off	on	off	off	on	on
1160		off	off	on	off	on	off	off	on	on
1170		off	on	on	off	on	off	off	on	on
1180		off	off	off	on	on	off	off	on	on
1190		off	on	off	on	on	off	off	on	on
1200		off	off	on	on	on	off	off	on	on
1210		off	on	on	on	on	off	off	on	on
1220		off	off	off	off	off	on	off	on	on
1230		off	on	off	off	off	on	off	on	on
1240		off	off	on	off	off	on	off	on	on
1250		off	on	on	off	off	on	off	on	on
1260		off	off	off	on	off	on	off	on	on
1270		off	on	off	on	off	on	off	on	on
1280		off	off	on	on	off	on	off	on	on
1290		off	on	on	on	off	on	off	on	on
1300		off	off	off	off	on	on	off	on	on
1310		off	on	off	off	on	on	off	on	on
1320		off	off	on	off	on	on	off	on	on
1330		off	on	on	off	on	on	off	on	on
1340		off	off	off	on	on	on	off	on	on
1350		off	on	off	on	on	on	off	on	on
1360		off	off	on	on	on	on	off	on	on
1370		off	on	on	on	on	on	off	on	on
1380		off	off	off	off	off	off	on	on	on
1390		off	on	off	off	off	off	on	on	on
1400		off	off	on	off	off	off	on	on	on



■ = OFF      □ = ON

PT Values		Switch Settings								
Pressing & Holding S1 causes all 8 switches on S2 to be saved according to the Rotary Switch S3. Always set all 8 S2 switches. See Figure 2.2 (p.4) and Table 5.A (p.21).										
PT Ratio (PT:1)	Rotary Switch	S3.1	S3.2							
	Setpoint Switch	S2.7	S2.1	S2.2	S2.3	S2.4	S2.5	S2.6	S2.7	S2.8
1410		off	on	on	off	off	off	on	on	on
1420		off	off	off	on	off	off	on	on	on
1430		off	on	off	on	off	off	on	on	on
1440		off	off	on	on	off	off	on	on	on
1450		off	on	on	on	off	off	on	on	on
1460		off	off	off	off	on	off	on	on	on
1470		off	on	off	off	on	off	on	on	on
1480		off	off	on	off	on	off	on	on	on
1490		off	on	on	off	on	off	on	on	on
1500		off	off	off	on	on	off	on	on	on
1510		off	on	off	on	on	off	on	on	on
1520		off	off	on	on	on	off	on	on	on
1530		off	on	on	on	on	off	on	on	on
1540		off	off	off	off	off	on	on	on	on
1550		off	on	off	off	off	on	on	on	on
1560		off	off	on	off	off	on	on	on	on
1570		off	on	on	off	off	on	on	on	on
1580		off	off	off	on	off	on	on	on	on
1590		off	on	off	on	off	on	on	on	on
1600		off	off	on	on	off	on	on	on	on
1610		off	on	on	on	off	on	on	on	on
1620		off	off	off	off	on	on	on	on	on
1630		off	on	off	off	on	on	on	on	on
1640		off	off	on	off	on	on	on	on	on
1650		off	on	on	off	on	on	on	on	on
1660		off	off	off	on	on	on	on	on	on
1670		off	on	off	on	on	on	on	on	on
1680		off	off	on	on	on	on	on	on	on
1690		off	on	on	on	on	on	on	on	on
1700		on	off	off	off	off	off	off	off	off
1710		on	on	off	off	off	off	off	off	off
1720		on	off	on	off	off	off	off	off	off
1730		on	on	on	off	off	off	off	off	off
1740		on	off	off	on	off	off	off	off	off
1750		on	on	off	on	off	off	off	off	off
1760		on	off	on	on	off	off	off	off	off
1770		on	on	on	on	off	off	off	off	off
1780		on	off	off	off	on	off	off	off	off

■ = OFF      □ = ON

PT		Switch Settings								
Values		Pressing & Holding S1 causes all 8 switches on S2 to be saved according to the Rotary Switch S3. Always set all 8 S2 switches. See Figure 2.2 (p.4) and Table 5.A (p.21).								
PT Ratio (PT:1)	Rotary Switch	S3.1	S3.2							
	Setpoint Switch	S2.7	S2.1	S2.2	S2.3	S2.4	S2.5	S2.6	S2.7	S2.8
1790		on	on	off	off	on	off	off	off	off
1800		on	off	on	off	on	off	off	off	off
1810		on	on	on	off	on	off	off	off	off
1820		on	off	off	on	on	off	off	off	off
1830		on	on	off	on	on	off	off	off	off
1840		on	off	on	on	on	off	off	off	off
1850		on	on	on	on	on	off	off	off	off
1860		on	off	off	off	off	on	off	off	off
1870		on	on	off	off	off	on	off	off	off
1880		on	off	on	off	off	on	off	off	off
1890		on	on	on	off	off	on	off	off	off
1900		on	off	off	on	off	on	off	off	off
1910		on	on	off	on	off	on	off	off	off
1920		on	off	on	on	off	on	off	off	off
1930		on	on	on	on	off	on	off	off	off
1940		on	off	off	off	on	on	off	off	off
1950		on	on	off	off	on	on	off	off	off
1960		on	off	on	off	on	on	off	off	off
1970		on	on	on	off	on	on	off	off	off
1980		on	off	off	on	on	on	off	off	off
1990		on	on	off	on	on	on	off	off	off
2000		on	off	on	on	on	on	off	off	off
2010		on	on	on	on	on	on	off	off	off
2020		on	off	off	off	off	off	on	off	off
2030		on	on	off	off	off	off	on	off	off
2040		on	off	on	off	off	off	on	off	off
2050		on	on	on	off	off	off	on	off	off
2060		on	off	off	on	off	off	on	off	off
2070		on	on	off	on	off	off	on	off	off
2080		on	off	on	on	off	off	on	off	off
2090		on	on	on	on	off	off	on	off	off
2100		on	off	off	off	on	off	on	off	off
2110		on	on	off	off	on	off	on	off	off
2120		on	off	on	off	on	off	on	off	off
2130		on	on	on	off	on	off	on	off	off
2140		on	off	off	on	on	off	on	off	off
2150		on	on	off	on	on	off	on	off	off

■ = OFF      □ = ON

PT Values		Switch Settings								
Pressing & Holding S1 causes all 8 switches on S2 to be saved according to the Rotary Switch S3. Always set all 8 S2 switches. See Figure 2.2 (p.4) and Table 5.A (p.21).										
PT Ratio (PT:1)	Rotary Switch	S3.1	S3.2							
	Setpoint Switch	S2.7	S2.1	S2.2	S2.3	S2.4	S2.5	S2.6	S2.7	S2.8
2160		on	off	on	on	on	off	on	off	off
2170		on	on	on	on	on	off	on	off	off
2180		on	off	off	off	off	on	on	off	off
2190		on	on	off	off	off	on	on	off	off
2200		on	off	on	off	off	on	on	off	off
2210		on	on	on	off	off	on	on	off	off
2220		on	off	off	on	off	on	on	off	off
2230		on	on	off	on	off	on	on	off	off
2240		on	off	on	on	off	on	on	off	off
2250		on	on	on	on	off	on	on	off	off
2260		on	off	off	off	on	on	on	off	off
2270		on	on	off	off	on	on	on	off	off
2280		on	off	on	off	on	on	on	off	off
2290		on	on	on	off	on	on	on	off	off
2300		on	off	off	on	on	on	on	off	off
2310		on	on	off	on	on	on	on	off	off
2320		on	off	on	on	on	on	on	off	off
2330		on	on	on	on	on	on	on	off	off
2340		on	off	off	off	off	off	off	on	off
2350		on	on	off	off	off	off	off	on	off
2360		on	off	on	off	off	off	off	on	off
2370		on	on	on	off	off	off	off	on	off
2380		on	off	off	on	off	off	off	on	off
2390		on	on	off	on	off	off	off	on	off
2400		on	off	on	on	off	off	off	on	off
2410		on	on	on	on	off	off	off	on	off
2420		on	off	off	off	on	off	off	on	off
2430		on	on	off	off	on	off	off	on	off
2440		on	off	on	off	on	off	off	on	off
2450		on	on	on	off	on	off	off	on	off
2460		on	off	off	on	on	off	off	on	off
2470		on	on	off	on	on	off	off	on	off
2480		on	off	on	on	on	off	off	on	off
2490		on	on	on	on	on	off	off	on	off
2500		on	off	off	off	off	on	off	on	off
2510		on	on	off	off	off	on	off	on	off
2520		on	off	on	off	off	on	off	on	off

■ = OFF      □ = ON

PT		Switch Settings								
Values	Pressing & Holding S1 causes all 8 switches on S2 to be saved according to the Rotary Switch S3. Always set all 8 S2 switches. See Figure 2.2 (p.4) and Table 5.A (p.21).									
PT Ratio (PT:1)	Rotary Switch	S3.1	S3.2							
	Setpoint Switch	S2.7	S2.1	S2.2	S2.3	S2.4	S2.5	S2.6	S2.7	S2.8
2530		on	on	on	off	off	on	off	on	off
2540		on	off	off	on	off	on	off	on	off
2550		on	on	off	on	off	on	off	on	off
2560		on	off	on	on	off	on	off	on	off
2570		on	on	on	on	off	on	off	on	off
2580		on	off	off	off	on	on	off	on	off
2590		on	on	off	off	on	on	off	on	off
2600		on	off	on	off	on	on	off	on	off
2610		on	on	on	off	on	on	off	on	off
2620		on	off	off	on	on	on	off	on	off
2630		on	on	off	on	on	on	off	on	off
2640		on	off	on	on	on	on	off	on	off
2650		on	on	on	on	on	on	off	on	off
2660		on	off	off	off	off	off	on	on	off
2670		on	on	off	off	off	off	on	on	off
2680		on	off	on	off	off	off	on	on	off
2690		on	on	on	off	off	off	on	on	off
2700		on	off	off	on	off	off	on	on	off
2710		on	on	off	on	off	off	on	on	off
2720		on	off	on	on	off	off	on	on	off
2730		on	on	on	on	off	off	on	on	off
2740		on	off	off	off	on	off	on	on	off
2750		on	on	off	off	on	off	on	on	off
2760		on	off	on	off	on	off	on	on	off
2770		on	on	on	off	on	off	on	on	off
2780		on	off	off	on	on	off	on	on	off
2790		on	on	off	on	on	off	on	on	off
2800		on	off	on	on	on	off	on	on	off
2810		on	on	on	on	on	off	on	on	off
2820		on	off	off	off	off	on	on	on	off
2830		on	on	off	off	off	on	on	on	off
2840		on	off	on	off	off	on	on	on	off
2850		on	on	on	off	off	on	on	on	off
2860		on	off	off	on	off	on	on	on	off
2870		on	on	off	on	off	on	on	on	off
2880		on	off	on	on	off	on	on	on	off
2890		on	on	on	on	off	on	on	on	off

■ = OFF      □ = ON

PT Values		Switch Settings								
Pressing & Holding S1 causes all 8 switches on S2 to be saved according to the Rotary Switch S3. Always set all 8 S2 switches. See Figure 2.2 (p.4) and Table 5.A (p.21).										
PT Ratio (PT:1)	Rotary Switch	S3.1	S3.2							
	Setpoint Switch	S2.7	S2.1	S2.2	S2.3	S2.4	S2.5	S2.6	S2.7	S2.8
2900		on	off	off	off	on	on	on	on	off
2910		on	on	off	off	on	on	on	on	off
2920		on	off	on	off	on	on	on	on	off
2930		on	on	on	off	on	on	on	on	off
2940		on	off	off	on	on	on	on	on	off
2950		on	on	off	on	on	on	on	on	off
2960		on	off	on	on	on	on	on	on	off
2970		on	on	on	on	on	on	on	on	off
2980		on	off	off	off	off	off	off	off	on
2990		on	on	off	off	off	off	off	off	on
3000		on	off	on	off	off	off	off	off	on
3010		on	on	on	off	off	off	off	off	on
3020		on	off	off	on	off	off	off	off	on
3030		on	on	off	on	off	off	off	off	on
3040		on	off	on	on	off	off	off	off	on
3050		on	on	on	on	off	off	off	off	on
3060		on	off	off	off	on	off	off	off	on
3070		on	on	off	off	on	off	off	off	on
3080		on	off	on	off	on	off	off	off	on
3090		on	on	on	off	on	off	off	off	on
3100		on	off	off	on	on	off	off	off	on
3110		on	on	off	on	on	off	off	off	on
3120		on	off	on	on	on	off	off	off	on
3130		on	on	on	on	on	off	off	off	on
3140		on	off	off	off	off	on	off	off	on
3150		on	on	off	off	off	on	off	off	on
3160		on	off	on	off	off	on	off	off	on
3170		on	on	on	off	off	on	off	off	on
3180		on	off	off	on	off	on	off	off	on
3190		on	on	off	on	off	on	off	off	on
3200		on	off	on	on	off	on	off	off	on
3210		on	on	on	on	off	on	off	off	on
3220		on	off	off	off	on	on	off	off	on
3230		on	on	off	off	on	on	off	off	on
3240		on	off	on	off	on	on	off	off	on
3250		on	on	on	off	on	on	off	off	on

■ = OFF      □ = ON

PT		Switch Settings								
Values	Pressing & Holding S1 causes all 8 switches on S2 to be saved according to the Rotary Switch S3. Always set all 8 S2 switches. See Figure 2.2 (p.4) and Table 5.A (p.21).									
PT Ratio (PT:1)	Rotary Switch	S3.1	S3.2							
	Setpoint Switch	S2.7	S2.1	S2.2	S2.3	S2.4	S2.5	S2.6	S2.7	S2.8
3260		on	off	off	on	on	on	off	off	on
3270		on	on	off	on	on	on	off	off	on
3280		on	off	on	on	on	on	off	off	on
3290		on	on	on	on	on	on	off	off	on
3300		on	off	off	off	off	off	on	off	on
3310		on	on	off	off	off	off	on	off	on
3320		on	off	on	off	off	off	on	off	on
3330		on	on	on	off	off	off	on	off	on
3340		on	off	off	on	off	off	on	off	on
3350		on	on	off	on	off	off	on	off	on
3360		on	off	on	on	off	off	on	off	on
3370		on	on	on	on	off	off	on	off	on
3380		on	off	off	off	on	off	on	off	on
3390		on	on	off	off	on	off	on	off	on
3400		on	off	on	off	on	off	on	off	on
3410		on	on	on	off	on	off	on	off	on
3420		on	off	off	on	on	off	on	off	on
3430		on	on	off	on	on	off	on	off	on
3440		on	off	on	on	on	off	on	off	on
3450		on	on	on	on	on	off	on	off	on
3460		on	off	off	off	off	on	on	off	on
3470		on	on	off	off	off	on	on	off	on
3480		on	off	on	off	off	on	on	off	on
3490		on	on	on	off	off	on	on	off	on
3500		on	off	off	on	off	on	on	off	on
3510		on	on	off	on	off	on	on	off	on
3520		on	off	on	on	off	on	on	off	on
3530		on	on	on	on	off	on	on	off	on
3540		on	off	off	off	on	on	on	off	on
3550		on	on	off	off	on	on	on	off	on
3560		on	off	on	off	on	on	on	off	on
3570		on	on	on	off	on	on	on	off	on
3580		on	off	off	on	on	on	on	off	on
3590		on	on	off	on	on	on	on	off	on
3600		on	off	on	on	on	on	on	off	on
3610		on	on	on	on	on	on	on	off	on

■ = OFF      □ = ON

PT Values		Switch Settings									
Pressing & Holding S1 causes all 8 switches on S2 to be saved according to the Rotary Switch S3. Always set all 8 S2 switches. See Figure 2.2 (p.4) and Table 5.A (p.21).											
PT Ratio (PT:1)	Rotary Switch	S3.1	S3.2								
	Setpoint Switch		S2.7	S2.1	S2.2	S2.3	S2.4	S2.5	S2.6	S2.7	S2.8
3620		on	off	off	off	off	off	off	off	on	on
3630		on	on	off	off	off	off	off	off	on	on
3640		on	off	on	off	off	off	off	off	on	on
3650		on	on	on	off	off	off	off	off	on	on
3660		on	off	off	on	off	off	off	off	on	on
3670		on	on	off	on	off	off	off	off	on	on
3680		on	off	on	on	off	off	off	off	on	on
3690		on	on	on	on	off	off	off	off	on	on
3700		on	off	off	off	on	off	off	off	on	on
3710		on	on	off	off	on	off	off	off	on	on
3720		on	off	on	off	on	off	off	off	on	on
3730		on	on	on	off	on	off	off	off	on	on
3740		on	off	off	on	on	off	off	off	on	on
3750		on	on	off	on	on	off	off	off	on	on
3760		on	off	on	on	on	off	off	off	on	on
3770		on	on	on	on	on	off	off	off	on	on
3780		on	off	off	off	off	on	off	off	on	on
3790		on	on	off	off	off	on	off	off	on	on
3800		on	off	on	off	off	on	off	off	on	on
3810		on	on	on	off	off	on	off	off	on	on
3820		on	off	off	on	off	on	off	off	on	on
3830		on	on	off	on	off	on	off	off	on	on
3840		on	off	on	on	off	on	off	off	on	on
3850		on	on	on	on	off	on	off	off	on	on
3860		on	off	off	off	on	on	off	off	on	on
3870		on	on	off	off	on	on	off	off	on	on
3880		on	off	on	off	on	on	off	off	on	on
3890		on	on	on	off	on	on	off	off	on	on
3900		on	off	off	on	on	on	off	off	on	on
3910		on	on	off	on	on	on	off	off	on	on
3920		on	off	on	on	on	on	off	off	on	on
3930		on	on	on	on	on	on	off	off	on	on
3940		on	off	off	off	off	off	on	off	on	on
3950		on	on	off	off	off	off	on	off	on	on
3960		on	off	on	off	off	off	on	off	on	on
3970		on	on	on	off	off	off	on	off	on	on

■ = OFF      □ = ON

PT		Switch Settings								
PT Ratio (PT:1)	Rotary Switch	Pressing & Holding S1 causes all 8 switches on S2 to be saved according to the Rotary Switch S3. Always set all 8 S2 switches. See Figure 2.2 (p.4) and Table 5.A (p.21).								
	Setpoint Switch	S3.1	S3.2							
		S2.7	S2.1	S2.2	S2.3	S2.4	S2.5	S2.6	S2.7	S2.8
3980		on	off	off	on	off	off	on	on	on
3990		on	on	off	on	off	off	on	on	on
4000		on	off	on	on	off	off	on	on	on
4010		on	on	on	on	off	off	on	on	on
4020		on	off	off	off	on	off	on	on	on
4030		on	on	off	off	on	off	on	on	on
4040		on	off	on	off	on	off	on	on	on
4050		on	on	on	off	on	off	on	on	on
4060		on	off	off	on	on	off	on	on	on
4070		on	on	off	on	on	off	on	on	on
4080		on	off	on	on	on	off	on	on	on
4090		on	on	on	on	on	off	on	on	on
4100		on	off	off	off	off	on	on	on	on
4110		on	on	off	off	off	on	on	on	on
4120		on	off	on	off	off	on	on	on	on
4130		on	on	on	off	off	on	on	on	on
4140		on	off	off	on	off	on	on	on	on
4150		on	on	off	on	off	on	on	on	on
4160		on	off	on	on	off	on	on	on	on
4170		on	on	on	on	off	on	on	on	on
4180		on	off	off	off	on	on	on	on	on
4190		on	on	off	off	on	on	on	on	on
4200		on	off	on	off	on	on	on	on	on
4210		on	on	on	off	on	on	on	on	on
4220		on	off	off	on	on	on	on	on	on
4230		on	on	off	on	on	on	on	on	on
4240		on	off	on	on	on	on	on	on	on
4250		on	on	on	on	on	on	on	on	on



■ = OFF      □ = ON

<b>CT</b>		<b>Switch Settings</b>								
<b>Values</b>		Pressing & Holding S1 causes all 8 switches on S2 to be saved according to the Rotary Switch S3. Always set all 8 S2 switches. See Figure 2.2 (p.4) and Table 5.A (p.21).								
<b>CT Primary (CT:5)</b>	Rotary Switch	S3.1	S3.3							
	Setpoint Switch	S2.8	S2.1	S2.2	S2.3	S2.4	S2.5	S2.6	S2.7	S2.8
5		off	off	off	off	off	off	off	off	off
10		off	on	off	off	off	off	off	off	off
15		off	off	on	off	off	off	off	off	off
20		off	on	on	off	off	off	off	off	off
25		off	off	off	on	off	off	off	off	off
30		off	on	off	on	off	off	off	off	off
35		off	off	on	on	off	off	off	off	off
40		off	on	on	on	off	off	off	off	off
45		off	off	off	off	on	off	off	off	off
50		off	on	off	off	on	off	off	off	off
55		off	off	on	off	on	off	off	off	off
60		off	on	on	off	on	off	off	off	off
65		off	off	off	on	on	off	off	off	off
70		off	on	off	on	on	off	off	off	off
75		off	off	on	on	on	off	off	off	off
80		off	on	on	on	on	off	off	off	off
85		off	off	off	off	off	on	off	off	off
90		off	on	off	off	off	on	off	off	off
95		off	off	on	off	off	on	off	off	off
100		off	on	on	off	off	on	off	off	off
105		off	off	off	on	off	on	off	off	off
110		off	on	off	on	off	on	off	off	off
115		off	off	on	on	off	on	off	off	off
120		off	on	on	on	off	on	off	off	off
125		off	off	off	off	on	on	off	off	off
130		off	on	off	off	on	on	off	off	off
135		off	off	on	off	on	on	off	off	off
140		off	on	on	off	on	on	off	off	off
145		off	off	off	on	on	on	off	off	off
150		off	on	off	on	on	on	off	off	off
155		off	off	on	on	on	on	off	off	off
160		off	on	on	on	on	on	off	off	off
165		off	off	off	off	off	off	on	off	off
170		off	on	off	off	off	off	on	off	off
175		off	off	on	off	off	off	on	off	off
180		off	on	on	off	off	off	on	off	off

■ = OFF      □ = ON

CT		Switch Settings								
Values		Pressing & Holding S1 causes all 8 switches on S2 to be saved according to the Rotary Switch S3. Always set all 8 S2 switches. See Figure 2.2 (p.4) and Table 5.A (p.21).								
CT Primary (CT:5)	Rotary Switch	S3.1	S3.3							
	Setpoint Switch	S2.8	S2.1	S2.2	S2.3	S2.4	S2.5	S2.6	S2.7	S2.8
185		off	off	off	on	off	off	on	off	off
190		off	on	off	on	off	off	on	off	off
195		off	off	on	on	off	off	on	off	off
200		off	on	on	on	off	off	on	off	off
205		off	off	off	off	on	off	on	off	off
210		off	on	off	off	on	off	on	off	off
215		off	off	on	off	on	off	on	off	off
220		off	on	on	off	on	off	on	off	off
225		off	off	off	on	on	off	on	off	off
230		off	on	off	on	on	off	on	off	off
235		off	off	on	on	on	off	on	off	off
240		off	on	on	on	on	off	on	off	off
245		off	off	off	off	off	on	on	off	off
250		off	on	off	off	off	on	on	off	off
255		off	off	on	off	off	on	on	off	off
260		off	on	on	off	off	on	on	off	off
265		off	off	off	on	off	on	on	off	off
270		off	on	off	on	off	on	on	off	off
275		off	off	on	on	off	on	on	off	off
280		off	on	on	on	off	on	on	off	off
285		off	off	off	off	on	on	on	off	off
290		off	on	off	off	on	on	on	off	off
295		off	off	on	off	on	on	on	off	off
300		off	on	on	off	on	on	on	off	off
305		off	off	off	on	on	on	on	off	off
310		off	on	off	on	on	on	on	off	off
315		off	off	on	on	on	on	on	off	off
320		off	on	on	on	on	on	on	off	off
325		off	off	off	off	off	off	off	on	off
330		off	on	off	off	off	off	off	on	off
335		off	off	on	off	off	off	off	on	off
340		off	on	on	off	off	off	off	on	off
345		off	off	off	on	off	off	off	on	off
350		off	on	off	on	off	off	off	on	off
355		off	off	on	on	off	off	off	on	off
360		off	on	on	on	off	off	off	on	off
365		off	off	off	off	on	off	off	on	off

■ = OFF      □ = ON

CT		Switch Settings								
Values	Rotary Switch	Pressing & Holding S1 causes all 8 switches on S2 to be saved according to the Rotary Switch S3. Always set all 8 S2 switches. See Figure 2.2 (p.4) and Table 5.A (p.21).								
CT Primary (CT:5)	Setpoint Switch	S3.1	S3.3							
		S2.8	S2.1	S2.2	S2.3	S2.4	S2.5	S2.6	S2.7	S2.8
370		off	on	off	off	on	off	off	on	off
375		off	off	on	off	on	off	off	on	off
380		off	on	on	off	on	off	off	on	off
385		off	off	off	on	on	off	off	on	off
390		off	on	off	on	on	off	off	on	off
395		off	off	on	on	on	off	off	on	off
400		off	on	on	on	on	off	off	on	off
405		off	off	off	off	off	on	off	on	off
410		off	on	off	off	off	on	off	on	off
415		off	off	on	off	off	on	off	on	off
420		off	on	on	off	off	on	off	on	off
425		off	off	off	on	off	on	off	on	off
430		off	on	off	on	off	on	off	on	off
435		off	off	on	on	off	on	off	on	off
440		off	on	on	on	off	on	off	on	off
445		off	off	off	off	on	on	off	on	off
450		off	on	off	off	on	on	off	on	off
455		off	off	on	off	on	on	off	on	off
460		off	on	on	off	on	on	off	on	off
465		off	off	off	on	on	on	off	on	off
470		off	on	off	on	on	on	off	on	off
475		off	off	on	on	on	on	off	on	off
480		off	on	on	on	on	on	off	on	off
485		off	off	off	off	off	off	on	on	off
490		off	on	off	off	off	off	on	on	off
495		off	off	on	off	off	off	on	on	off
500		off	on	on	off	off	off	on	on	off
505		off	off	off	on	off	off	on	on	off
510		off	on	off	on	off	off	on	on	off
515		off	off	on	on	off	off	on	on	off
520		off	on	on	on	off	off	on	on	off
525		off	off	off	off	on	off	on	on	off
530		off	on	off	off	on	off	on	on	off
535		off	off	on	off	on	off	on	on	off
540		off	on	on	off	on	off	on	on	off
545		off	off	off	on	on	off	on	on	off
550		off	on	off	on	on	off	on	on	off
555		off	off	on	on	on	off	on	on	off
560		off	on	on	on	on	off	on	on	off
565		off	off	off	off	off	on	on	on	off

■ = OFF      □ = ON

CT Switch Settings										
Values	Pressing & Holding S1 causes all 8 switches on S2 to be saved according to the Rotary Switch S3. Always set all 8 S2 switches. See Figure 2.2 (p.4) and Table 5.A (p.21).									
CT Primary (CT:5)	Rotary Switch	S3.1	S3.3							
	Setpoint Switch	S2.8	S2.1	S2.2	S2.3	S2.4	S2.5	S2.6	S2.7	S2.8
570		off	on	off	off	off	on	on	on	off
575		off	off	on	off	off	on	on	on	off
580		off	on	on	off	off	on	on	on	off
585		off	off	off	on	off	on	on	on	off
590		off	on	off	on	off	on	on	on	off
595		off	off	on	on	off	on	on	on	off
600		off	on	on	on	off	on	on	on	off
605		off	off	off	off	on	on	on	on	off
610		off	on	off	off	on	on	on	on	off
615		off	off	on	off	on	on	on	on	off
620		off	on	on	off	on	on	on	on	off
625		off	off	off	on	on	on	on	on	off
630		off	on	off	on	on	on	on	on	off
635		off	off	on	on	on	on	on	on	off
640		off	on	on	on	on	on	on	on	off
645		off	off	off	off	off	off	off	off	on
650		off	on	off	off	off	off	off	off	on
655		off	off	on	off	off	off	off	off	on
660		off	on	on	off	off	off	off	off	on
665		off	off	off	on	off	off	off	off	on
670		off	on	off	on	off	off	off	off	on
675		off	off	on	on	off	off	off	off	on
680		off	on	on	on	off	off	off	off	on
685		off	off	off	off	on	off	off	off	on
690		off	on	off	off	on	off	off	off	on
695		off	off	on	off	on	off	off	off	on
700		off	on	on	off	on	off	off	off	on
705		off	off	off	on	on	off	off	off	on
710		off	on	off	on	on	off	off	off	on
715		off	off	on	on	on	off	off	off	on
720		off	on	on	on	on	off	off	off	on
725		off	off	off	off	off	on	off	off	on
730		off	on	off	off	off	on	off	off	on
735		off	off	on	off	off	on	off	off	on
740		off	on	on	off	off	on	off	off	on
745		off	off	off	on	off	on	off	off	on
750		off	on	off	on	off	on	off	off	on
755		off	off	on	on	off	on	off	off	on

■ = OFF      □ = ON

CT		Switch Settings								
Values		Pressing & Holding S1 causes all 8 switches on S2 to be saved according to the Rotary Switch S3. Always set all 8 S2 switches. See Figure 2.2 (p.4) and Table 5.A (p.21).								
CT Primary (CT:5)	Rotary Switch	S3.1	S3.3							
	Setpoint Switch	S2.8	S2.1	S2.2	S2.3	S2.4	S2.5	S2.6	S2.7	S2.8
760		off	on	on	on	off	on	off	off	on
765		off	off	off	off	on	on	off	off	on
770		off	on	off	off	on	on	off	off	on
775		off	off	on	off	on	on	off	off	on
780		off	on	on	off	on	on	off	off	on
785		off	off	off	on	on	on	off	off	on
790		off	on	off	on	on	on	off	off	on
795		off	off	on	on	on	on	off	off	on
800		off	on	on	on	on	on	off	off	on
805		off	off	off	off	off	off	on	off	on
810		off	on	off	off	off	off	on	off	on
815		off	off	on	off	off	off	on	off	on
820		off	on	on	off	off	off	on	off	on
825		off	off	off	on	off	off	on	off	on
830		off	on	off	on	off	off	on	off	on
835		off	off	on	on	off	off	on	off	on
840		off	on	on	on	off	off	on	off	on
845		off	off	off	off	on	off	on	off	on
850		off	on	off	off	on	off	on	off	on
855		off	off	on	off	on	off	on	off	on
860		off	on	on	off	on	off	on	off	on
865		off	off	off	on	on	off	on	off	on
870		off	on	off	on	on	off	on	off	on
875		off	off	on	on	on	off	on	off	on
880		off	on	on	on	on	off	on	off	on
885		off	off	off	off	off	on	on	off	on
890		off	on	off	off	off	on	on	off	on
895		off	off	on	off	off	on	on	off	on
900		off	on	on	off	off	on	on	off	on
905		off	off	off	on	off	on	on	off	on
910		off	on	off	on	off	on	on	off	on
915		off	off	on	on	off	on	on	off	on
920		off	on	on	on	off	on	on	off	on
925		off	off	off	off	on	on	on	off	on
930		off	on	off	off	on	on	on	off	on
935		off	off	on	off	on	on	on	off	on
940		off	on	on	off	on	on	on	off	on
945		off	off	off	on	on	on	on	off	on

■ = OFF      □ = ON

CT Switch Settings										
Values Pressing & Holding S1 causes all 8 switches on S2 to be saved according to the Rotary Switch S3. Always set all 8 S2 switches. See Figure 2.2 (p.4) and Table 5.A (p.21).										
CT Primary (CT:5)	Rotary Switch	S3.3								
	Setpoint Switch	S2.8	S2.1	S2.2	S2.3	S2.4	S2.5	S2.6	S2.7	S2.8
950		off	on	off	on	on	on	on	off	on
955		off	off	on	on	on	on	on	off	on
960		off	on	on	on	on	on	on	off	on
965		off	off	off	off	off	off	off	on	on
970		off	on	off	off	off	off	off	on	on
975		off	off	on	off	off	off	off	on	on
980		off	on	on	off	off	off	off	on	on
985		off	off	off	on	off	off	off	on	on
990		off	on	off	on	off	off	off	on	on
995		off	off	on	on	off	off	off	on	on
1000		off	on	on	on	off	off	off	on	on
1005		off	off	off	off	on	off	off	on	on
1010		off	on	off	off	on	off	off	on	on
1015		off	off	on	off	on	off	off	on	on
1020		off	on	on	off	on	off	off	on	on
1025		off	off	off	on	on	off	off	on	on
1030		off	on	off	on	on	off	off	on	on
1035		off	off	on	on	on	off	off	on	on
1040		off	on	on	on	on	off	off	on	on
1045		off	off	off	off	off	on	off	on	on
1050		off	on	off	off	off	on	off	on	on
1055		off	off	on	off	off	on	off	on	on
1060		off	on	on	off	off	on	off	on	on
1065		off	off	off	on	off	on	off	on	on
1070		off	on	off	on	off	on	off	on	on
1075		off	off	on	on	off	on	off	on	on
1080		off	on	on	on	off	on	off	on	on
1085		off	off	off	off	on	on	off	on	on
1090		off	on	off	off	on	on	off	on	on
1095		off	off	on	off	on	on	off	on	on
1100		off	on	on	off	on	on	off	on	on
1105		off	off	off	on	on	on	off	on	on
1110		off	on	off	on	on	on	off	on	on
1115		off	off	on	on	on	on	off	on	on
1120		off	on	on	on	on	on	off	on	on
1125		off	off	off	off	off	off	on	on	on
1130		off	on	off	off	off	off	on	on	on
1135		off	off	on	off	off	off	on	on	on

■ = OFF      □ = ON

CT		Switch Settings								
Values		Pressing & Holding S1 causes all 8 switches on S2 to be saved according to the Rotary Switch S3. Always set all 8 S2 switches. See Figure 2.2 (p.4) and Table 5.A (p.21).								
CT Primary (CT:5)	Rotary Switch	S3.1	S3.3							
	Setpoint Switch	S2.8	S2.1	S2.2	S2.3	S2.4	S2.5	S2.6	S2.7	S2.8
1140		off	on	on	off	off	off	on	on	on
1145		off	off	off	on	off	off	on	on	on
1150		off	on	off	on	off	off	on	on	on
1155		off	off	on	on	off	off	on	on	on
1160		off	on	on	on	off	off	on	on	on
1165		off	off	off	off	on	off	on	on	on
1170		off	on	off	off	on	off	on	on	on
1175		off	off	on	off	on	off	on	on	on
1180		off	on	on	off	on	off	on	on	on
1185		off	off	off	on	on	off	on	on	on
1190		off	on	off	on	on	off	on	on	on
1195		off	off	on	on	on	off	on	on	on
1200		off	on	on	on	on	off	on	on	on
1205		off	off	off	off	off	on	on	on	on
1210		off	on	off	off	off	on	on	on	on
1215		off	off	on	off	off	on	on	on	on
1220		off	on	on	off	off	on	on	on	on
1225		off	off	off	on	off	on	on	on	on
1230		off	on	off	on	off	on	on	on	on
1235		off	off	on	on	off	on	on	on	on
1240		off	on	on	on	off	on	on	on	on
1245		off	off	off	off	on	on	on	on	on
1250		off	on	off	off	on	on	on	on	on
1255		off	off	on	off	on	on	on	on	on
1260		off	on	on	off	on	on	on	on	on
1265		off	off	off	on	on	on	on	on	on
1270		off	on	off	on	on	on	on	on	on
1275		off	off	on	on	on	on	on	on	on
1280		off	on	on	on	on	on	on	on	on
*50		on	off	off	off	off	off	off	off	off
*100		on	on	off	off	off	off	off	off	off
*150		on	off	on	off	off	off	off	off	off
*200		on	on	on	off	off	off	off	off	off
*250		on	off	off	on	off	off	off	off	off
*300		on	on	off	on	off	off	off	off	off
*350		on	off	on	on	off	off	off	off	off
*400		on	on	on	on	off	off	off	off	off
*450		on	off	off	off	on	off	off	off	off

\* These CT Primary values are repeated from previous pages. Either setting is acceptable.

■ = OFF      □ = ON

<b>CT</b>										
<b>Switch Settings</b>										
<b>Values</b>	<b>Pressing &amp; Holding S1 causes all 8 switches on S2 to be saved according to the Rotary Switch S3. Always set all 8 S2 switches. See Figure 2.2 (p.4) and Table 5.A (p.21).</b>									
<b>CT Primary (CT:5)</b>	Rotary Switch	S3.3								
	Setpoint Switch	S2.8	S2.1	S2.2	S2.3	S2.4	S2.5	S2.6	S2.7	S2.8
*500		on	on	off	off	on	off	off	off	off
*550		on	off	on	off	on	off	off	off	off
*600		on	on	on	off	on	off	off	off	off
*650		on	off	off	on	on	off	off	off	off
*700		on	on	off	on	on	off	off	off	off
*750		on	off	on	on	on	off	off	off	off
*800		on	on	on	on	on	off	off	off	off
*850		on	off	off	off	off	on	off	off	off
*900		on	on	off	off	off	on	off	off	off
*950		on	off	on	off	off	on	off	off	off
*1000		on	on	on	off	off	on	off	off	off
*1050		on	off	off	on	off	on	off	off	off
*1100		on	on	off	on	off	on	off	off	off
*1150		on	off	on	on	off	on	off	off	off
*1200		on	on	on	on	off	on	off	off	off
*1250		on	off	off	off	on	on	off	off	off
1300		on	on	off	off	on	on	off	off	off
1350		on	off	on	off	on	on	off	off	off
1400		on	on	on	off	on	on	off	off	off
1450		on	off	off	on	on	on	off	off	off
1500		on	on	off	on	on	on	off	off	off
1550		on	off	on	on	on	on	off	off	off
1600		on	on	on	on	on	on	off	off	off
1650		on	off	off	off	off	off	on	off	off
1700		on	on	off	off	off	off	on	off	off
1750		on	off	on	off	off	off	on	off	off
1800		on	on	on	off	off	off	on	off	off
1850		on	off	off	on	off	off	on	off	off
1900		on	on	off	on	off	off	on	off	off
1950		on	off	on	on	off	off	on	off	off
2000		on	on	on	on	off	off	on	off	off
2050		on	off	off	off	on	off	on	off	off
2100		on	on	off	off	on	off	on	off	off
2150		on	off	on	off	on	off	on	off	off
2200		on	on	on	off	on	off	on	off	off
2250		on	off	off	on	on	off	on	off	off
2300		on	on	off	on	on	off	on	off	off

\* These CT Primary values are repeated from previous pages. Either setting is acceptable



■ = OFF      □ = ON

CT		Switch Settings								
Values	Pressing & Holding S1 causes all 8 switches on S2 to be saved according to the Rotary Switch S3. Always set all 8 S2 switches. See Figure 2.2 (p.4) and Table 5.A (p.21).									
CT Primary (CT:5)	Rotary Switch	S3.1	S3.3							
	Setpoint Switch	S2.8	S2.1	S2.2	S2.3	S2.4	S2.5	S2.6	S2.7	S2.8
2350		on	off	on	on	on	off	on	off	off
2400		on	on	on	on	on	off	on	off	off
2450		on	off	off	off	off	on	on	off	off
2500		on	on	off	off	off	on	on	off	off
2550		on	off	on	off	off	on	on	off	off
2600		on	on	on	off	off	on	on	off	off
2650		on	off	off	on	off	on	on	off	off
2700		on	on	off	on	off	on	on	off	off
2750		on	off	on	on	off	on	on	off	off
2800		on	on	on	on	off	on	on	off	off
2850		on	off	off	off	on	on	on	off	off
2900		on	on	off	off	on	on	on	off	off
2950		on	off	on	off	on	on	on	off	off
3000		on	on	on	off	on	on	on	off	off
3050		on	off	off	on	on	on	on	off	off
3100		on	on	off	on	on	on	on	off	off
3150		on	off	on	on	on	on	on	off	off
3200		on	on	on	on	on	on	on	off	off
3250		on	off	off	off	off	off	off	on	off
3300		on	on	off	off	off	off	off	on	off
3350		on	off	on	off	off	off	off	on	off
3400		on	on	on	off	off	off	off	on	off
3450		on	off	off	on	off	off	off	on	off
3500		on	on	off	on	off	off	off	on	off
3550		on	off	on	on	off	off	off	on	off
3600		on	on	on	on	off	off	off	on	off
3650		on	off	off	off	on	off	off	on	off
3700		on	on	off	off	on	off	off	on	off
3750		on	off	on	off	on	off	off	on	off
3800		on	on	on	off	on	off	off	on	off
3850		on	off	off	on	on	off	off	on	off
3900		on	on	off	on	on	off	off	on	off
3950		on	off	on	on	on	off	off	on	off
4000		on	on	on	on	on	off	off	on	off
4050		on	off	off	off	off	on	off	on	off
4100		on	on	off	off	off	on	off	on	off
4150		on	off	on	off	off	on	off	on	off

■ = OFF      □ = ON

CT		Switch Settings								
Values	Rotary Switch	Pressing & Holding S1 causes all 8 switches on S2 to be saved according to the Rotary Switch S3. Always set all 8 S2 switches. See Figure 2.2 (p.4) and Table 5.A (p.21).								
CT Primary (CT:5)	Setpoint Switch	S3.1	S3.3							
		S2.8	S2.1	S2.2	S2.3	S2.4	S2.5	S2.6	S2.7	S2.8
4200		on	on	on	off	off	on	off	on	off
4250		on	off	off	on	off	on	off	on	off
4300		on	on	off	on	off	on	off	on	off
4350		on	off	on	on	off	on	off	on	off
4400		on	on	on	on	off	on	off	on	off
4450		on	off	off	off	on	on	off	on	off
4500		on	on	off	off	on	on	off	on	off
4550		on	off	on	off	on	on	off	on	off
4600		on	on	on	off	on	on	off	on	off
4650		on	off	off	on	on	on	off	on	off
4700		on	on	off	on	on	on	off	on	off
4750		on	off	on	on	on	on	off	on	off
4800		on	on	on	on	on	on	off	on	off
4850		on	off	off	off	off	off	on	on	off
4900		on	on	off	off	off	off	on	on	off
4950		on	off	on	off	off	off	on	on	off
5000		on	on	on	off	off	off	on	on	off
5050		on	off	off	on	off	off	on	on	off
5100		on	on	off	on	off	off	on	on	off
5150		on	off	on	on	off	off	on	on	off
5200		on	on	on	on	off	off	on	on	off
5250		on	off	off	off	on	off	on	on	off
5300		on	on	off	off	on	off	on	on	off
5350		on	off	on	off	on	off	on	on	off
5400		on	on	on	off	on	off	on	on	off
5450		on	off	off	on	on	off	on	on	off
5500		on	on	off	on	on	off	on	on	off
5550		on	off	on	on	on	off	on	on	off
5600		on	on	on	on	on	off	on	on	off
5650		on	off	off	off	off	on	on	on	off
5700		on	on	off	off	off	on	on	on	off
5750		on	off	on	off	off	on	on	on	off
5800		on	on	on	off	off	on	on	on	off
5850		on	off	off	on	off	on	on	on	off
5900		on	on	off	on	off	on	on	on	off
5950		on	off	on	on	off	on	on	on	off
6000		on	on	on	on	off	on	on	on	off

■ = OFF      □ = ON

CT		Switch Settings								
Values	Rotary Switch	Pressing & Holding S1 causes all 8 switches on S2 to be saved according to the Rotary Switch S3. Always set all 8 S2 switches. See Figure 2.2 (p.4) and Table 5.A (p.21).								
CT Primary (CT:5)	Setpoint Switch	S3.1	S3.3							
		S2.8	S2.1	S2.2	S2.3	S2.4	S2.5	S2.6	S2.7	S2.8
6050		on	off	off	off	on	on	on	on	off
6100		on	on	off	off	on	on	on	on	off
6150		on	off	on	off	on	on	on	on	off
6200		on	on	on	off	on	on	on	on	off
6250		on	off	off	on	on	on	on	on	off
6300		on	on	off	on	on	on	on	on	off
6350		on	off	on	on	on	on	on	on	off
6400		on	on	on	on	on	on	on	on	off
6450		on	off	off	off	off	off	off	off	on
6500		on	on	off	off	off	off	off	off	on
6550		on	off	on	off	off	off	off	off	on
6600		on	on	on	off	off	off	off	off	on
6650		on	off	off	on	off	off	off	off	on
6700		on	on	off	on	off	off	off	off	on
6750		on	off	on	on	off	off	off	off	on
6800		on	on	on	on	off	off	off	off	on
6850		on	off	off	off	on	off	off	off	on
6900		on	on	off	off	on	off	off	off	on
6950		on	off	on	off	on	off	off	off	on
7000		on	on	on	off	on	off	off	off	on
7050		on	off	off	on	on	off	off	off	on
7100		on	on	off	on	on	off	off	off	on
7150		on	off	on	on	on	off	off	off	on
7200		on	on	on	on	on	off	off	off	on
7250		on	off	off	off	off	on	off	off	on
7300		on	on	off	off	off	on	off	off	on
7350		on	off	on	off	off	on	off	off	on
7400		on	on	on	off	off	on	off	off	on
7450		on	off	off	on	off	on	off	off	on
7500		on	on	off	on	off	on	off	off	on
7550		on	off	on	on	off	on	off	off	on
7600		on	on	on	on	off	on	off	off	on
7650		on	off	off	off	on	on	off	off	on
7700		on	on	off	off	on	on	off	off	on
7750		on	off	on	off	on	on	off	off	on
7800		on	on	on	off	on	on	off	off	on

■ = OFF      □ = ON

CT		Switch Settings								
Values	Rotary Switch	Pressing & Holding S1 causes all 8 switches on S2 to be saved according to the Rotary Switch S3. Always set all 8 S2 switches. See Figure 2.2 (p.4) and Table 5.A (p.21).								
CT Primary (CT:5)	Setpoint Switch	S3.1	S3.3							
		S2.8	S2.1	S2.2	S2.3	S2.4	S2.5	S2.6	S2.7	S2.8
7850		on	off	off	on	on	on	off	off	on
7900		on	on	off	on	on	on	off	off	on
7950		on	off	on	on	on	on	off	off	on
8000		on	on	on	on	on	on	off	off	on
8050		on	off	off	off	off	off	on	off	on
8100		on	on	off	off	off	off	on	off	on
8150		on	off	on	off	off	off	on	off	on
8200		on	on	on	off	off	off	on	off	on
8250		on	off	off	on	off	off	on	off	on
8300		on	on	off	on	off	off	on	off	on
8350		on	off	on	on	off	off	on	off	on
8400		on	on	on	on	off	off	on	off	on
8450		on	off	off	off	on	off	on	off	on
8500		on	on	off	off	on	off	on	off	on
8550		on	off	on	off	on	off	on	off	on
8600		on	on	on	off	on	off	on	off	on
8650		on	off	off	on	on	off	on	off	on
8700		on	on	off	on	on	off	on	off	on
8750		on	off	on	on	on	off	on	off	on
8800		on	on	on	on	on	off	on	off	on
8850		on	off	off	off	off	on	on	off	on
8900		on	on	off	off	off	on	on	off	on
8950		on	off	on	off	off	on	on	off	on
9000		on	on	on	off	off	on	on	off	on
9050		on	off	off	on	off	on	on	off	on
9100		on	on	off	on	off	on	on	off	on
9150		on	off	on	on	off	on	on	off	on
9200		on	on	on	on	off	on	on	off	on
9250		on	off	off	off	on	on	on	off	on
9300		on	on	off	off	on	on	on	off	on
9350		on	off	on	off	on	on	on	off	on
9400		on	on	on	off	on	on	on	off	on
9450		on	off	off	on	on	on	on	off	on
9500		on	on	off	on	on	on	on	off	on
9550		on	off	on	on	on	on	on	off	on
9600		on	on	on	on	on	on	on	off	on

■ = OFF      □ = ON

CT		Switch Settings								
Values		Pressing & Holding S1 causes all 8 switches on S2 to be saved according to the Rotary Switch S3. Always set all 8 S2 switches. See Figure 2.2 (p.4) and Table 5.A (p.21).								
CT Primary (CT:5)	Rotary Switch	S3.1	S3.3							
	Setpoint Switch	S2.8	S2.1	S2.2	S2.3	S2.4	S2.5	S2.6	S2.7	S2.8
9650		on	off	off	off	off	off	off	on	on
9700		on	on	off	off	off	off	off	on	on
9750		on	off	on	off	off	off	off	on	on
9800		on	on	on	off	off	off	off	on	on
9850		on	off	off	on	off	off	off	on	on
9900		on	on	off	on	off	off	off	on	on
9950		on	off	on	on	off	off	off	on	on
10000		on	on	on	on	off	off	off	on	on
10050		on	off	off	off	on	off	off	on	on
10100		on	on	off	off	on	off	off	on	on
10150		on	off	on	off	on	off	off	on	on
10200		on	on	on	off	on	off	off	on	on
10250		on	off	off	on	on	off	off	on	on
10300		on	on	off	on	on	off	off	on	on
10350		on	off	on	on	on	off	off	on	on
10400		on	on	on	on	on	off	off	on	on
10450		on	off	off	off	off	on	off	on	on
10500		on	on	off	off	off	on	off	on	on
10550		on	off	on	off	off	on	off	on	on
10600		on	on	on	off	off	on	off	on	on
10650		on	off	off	on	off	on	off	on	on
10700		on	on	off	on	off	on	off	on	on
10750		on	off	on	on	off	on	off	on	on
10800		on	on	on	on	off	on	off	on	on
10850		on	off	off	off	on	on	off	on	on
10900		on	on	off	off	on	on	off	on	on
10950		on	off	on	off	on	on	off	on	on
11000		on	on	on	off	on	on	off	on	on
11050		on	off	off	on	on	on	off	on	on
11100		on	on	off	on	on	on	off	on	on
11150		on	off	on	on	on	on	off	on	on
11200		on	on	on	on	on	on	off	on	on
11250		on	off	off	off	off	off	on	on	on
11300		on	on	off	off	off	off	on	on	on
11350		on	off	on	off	off	off	on	on	on
11400		on	on	on	off	off	off	on	on	on

■ = OFF      □ = ON

<b>CT</b>		<b>Switch Settings</b>								
<b>Values</b>	Pressing & Holding S1 causes all 8 switches on S2 to be saved according to the Rotary Switch S3. Always set all 8 S2 switches. See Figure 2.2 (p.4) and Table 5.A (p.21).									
<b>CT Primary (CT:5)</b>	Rotary Switch	S3.1	S3.3							
	Setpoint Switch	S2.8	S2.1	S2.2	S2.3	S2.4	S2.5	S2.6	S2.7	S2.8
11450		on	off	off	on	off	off	on	on	on
11500		on	on	off	on	off	off	on	on	on
11550		on	off	on	on	off	off	on	on	on
11600		on	on	on	on	off	off	on	on	on
11650		on	off	off	off	on	off	on	on	on
11700		on	on	off	off	on	off	on	on	on
11750		on	off	on	off	on	off	on	on	on
11800		on	on	on	off	on	off	on	on	on
11850		on	off	off	on	on	off	on	on	on
11900		on	on	off	on	on	off	on	on	on
11950		on	off	on	on	on	off	on	on	on
12000		on	on	on	on	on	off	on	on	on
12050		on	off	off	off	off	on	on	on	on
12100		on	on	off	off	off	on	on	on	on
12150		on	off	on	off	off	on	on	on	on
12200		on	on	on	off	off	on	on	on	on
12250		on	off	off	on	off	on	on	on	on
12300		on	on	off	on	off	on	on	on	on
12350		on	off	on	on	off	on	on	on	on
12400		on	on	on	on	off	on	on	on	on
12450		on	off	off	off	on	on	on	on	on
12500		on	on	off	off	on	on	on	on	on
12550		on	off	on	off	on	on	on	on	on
12600		on	on	on	off	on	on	on	on	on
12650		on	off	off	on	on	on	on	on	on
12700		on	on	off	on	on	on	on	on	on
12750		on	off	on	on	on	on	on	on	on
12800		on	on	on	on	on	on	on	on	on

**Master Setpoint Record Sheet**

Once you have determined the settings for your setpoint switches, record them in this table. Remove and store this table in several locations and keep it up-to-date when you change settings.

**Pressing & Holding S1 causes all 8 switches on S2 to be saved according to the Rotary Switch S3. Always set all 8 S2 switches. See Figure 2.2 (p.4) and Table 5.A (p.21).**

Rotary Select Switch	Setpoint Switches							
	S2.1	S2.2	S2.3.	S2.4	S2.5	S2.6	S2.7	S2.8
S3.1								
S3.2								
S3.3								
S3.4								
S3.5			Not Used					
S3.6								
S3.7								
S3.8								
S3.9								
S3.A								
S3.B								
S3.C								
S3.D								
S3.E								
S3.F								

In the Setpoint Display rows, shade the cells of the numbers for which the LED's should light. This will allow you to easily verify the settings for each Select Switch. In the Setpoint Switch row, indicate beside each switch whether the switch is to the left (Off) or to the right (On). The ninth Setpoint Display is not used. The tenth lights only when you hold the Save button long enough (about four seconds) to save the settings for the current Select Switch.

Use the following pages to record your settings for each setpoint. They are organized by General System, Alarm 1, Alarm 2, and Optional I/O Setpoints.

This page contains the settings for Rotary Select Switch (S3) positions 1 to 9. The settings for positions A to F are on the next page.

**Pressing & Holding S1 causes all 8 switches on S2 to be saved according to the Rotary Switch S3. Always set all 8 S2 switches. See Figure 2.2 (p.4) and Table 5.A (p.21).**

	<b>S3.1</b>	<b>S3.2</b>	<b>S3.3</b>	<b>S3.4</b>	<b>S3.5</b>	<b>S3.6</b>	<b>S3.7</b>	<b>S3.8</b>	<b>S3.9</b>
(DS30) Setpoint Display LED Bank	1.	1.	1.	1.	1.	1.	1.	1.	1.
	2.	2.	2.	2.	2.	2.	2.	2.	2.
	3.	3.	3.	3.	3.	3.	3.	3.	3.
	4.	4.	4.	4.	4.	4.	4.	4.	4.
	5.	5.	5.	5.	5.	5.	5.	5.	5.
	6.	6.	6.	6.	6.	6.	6.	6.	6.
	7.	7.	7.	7.	7.	7.	7.	7.	7.
	8.	8.	8.	8.	8.	8.	8.	8.	8.
(S2) Setpoint Switch positions	1.	1.	1.	1.	1.	1.	1.	1.	1.
	2.	2.	2.	2.	2.	2.	2.	2.	2.
	3.	3.	3.	3.	3.	3.	3.	3.	3.
	4.	4.	4.	4.	4.	4.	4.	4.	4.
	5.	5.	5.	5.	5.	5.	5.	5.	5.
	6.	6.	6.	6.	6.	6.	6.	6.	6.
	7.	7.	7.	7.	7.	7.	7.	7.	7.
	8.	8.	8.	8.	8.	8.	8.	8.	8.



Pressing & Holding S1 causes all 8 switches on S2 to be saved according to the Rotary Switch S3. Always set all 8 S2 switches. See Figure 2.2 (p.4) and Table 5.A (p.21).

	S3.A	S3.B	S3.C	S3.D	S3.E	S3.F
(DS30) Setpoint Display LED Bank	1.	1.	1.	1.	1.	1.
	2.	2.	2.	2.	2.	2.
	3.	3.	3.	3.	3.	3.
	4.	4.	4.	4.	4.	4.
	5.	5.	5.	5.	5.	5.
	6.	6.	6.	6.	6.	6.
	7.	7.	7.	7.	7.	7.
	8.	8.	8.	8.	8.	8.
(S2) Setpoint Switch positions	1.	1.	1.	1.	1.	1.
	2.	2.	2.	2.	2.	2.
	3.	3.	3.	3.	3.	3.
	4.	4.	4.	4.	4.	4.
	5.	5.	5.	5.	5.	5.
	6.	6.	6.	6.	6.	6.
	7.	7.	7.	7.	7.	7.
	8.	8.	8.	8.	8.	8.

# General System Setpoint Record Sheet

Pressing & Holding S1 causes all 8 switches on S2 to be saved according to the Rotary Switch S3. Always set all 8 S2 switches. See Figure 2.2 (p.4) and Table 5.A (p.21).

### System Configuration

■ = OFF   □ = ON   ■ = Not Applicable

Rotary Switch	Setpoint Switch (S2.#)							
Position	1	2	3	4	5	6	7	8
S3.1		■	■	■	■	■	■	■

OFF = 3-Wire

ON = 4-Wire

### Frequency Selection

■ = OFF   □ = ON   ■ = Not Applicable

Rotary Switch	Setpoint Switch (S2.#)							
Position	1	2	3	4	5	6	7	8
S3.1	■	■	■	■	■	■	■	■

OFF = 50 Hz

ON = 60 Hz

### Nominal AC Line Voltage

■ = OFF   □ = ON   ■ = Not Applicable

Rotary Switch	Setpoint Switch (S2.#)							
Position	1	2	3	4	5	6	7	8
S3.1	■	■	■	■	■	■	■	■

See Table 5.F

### Voltage Transformer Ratio

■ = OFF   □ = ON   ■ = Not Applicable

Rotary Switch	Setpoint Switch (S2.#)							
Position	1	2	3	4	5	6	7	8
S3.1	■	■	■	■	■	■	■	■
S3.2								

See Appendix A

### Current Transformer Primary

■ = OFF   □ = ON   ■ = Not Applicable

Rotary Switch	Setpoint Switch (S2.#)							
Position	1	2	3	4	5	6	7	8
S3.1	■	■	■	■	■	■	■	■
S3.3								

See Appendix A

### Phase Sequence

■ = OFF   □ = ON   ■ = Not Applicable

Rotary Switch	Setpoint Switch (S2.#)							
Position	1	2	3	4	5	6	7	8
S3.4	■	■	■	■	■	■	■	■

OFF = ABC

ON = CBA

Pressing & Holding S1 causes all 8 switches on S2 to be saved according to the Rotary Switch S3. Always set all 8 S2 switches. See Figure 2.2 (p.4) and Table 5.A (p.21).

**Power Demand Window**

■ = OFF □ = ON ▒ = Not Applicable

Rotary Switch	Setpoint Switch (S2.#)							
Position	1	2	3	4	5	6	7	8
S3.4	▒	▒	▒	▒	▒	▒	▒	▒

OFF = Sliding

ON = Fixed

**Power Demand Time Interval**

■ = OFF □ = ON ▒ = Not Applicable

Rotary Switch	Setpoint Switch (S2.#)							
Position	1	2	3	4	5	6	7	8
S3.4	▒	▒	▒	▒	▒	▒	▒	▒

See Table 5.G

**Current Demand Time Interval**

■ = OFF □ = ON ▒ = Not Applicable

Rotary Switch	Setpoint Switch (S2.#)							
Position	1	2	3	4	5	6	7	8
S3.4	▒	▒	▒	▒	▒	▒	▒	▒

See Table 5.H

**Reset Energy from Faceplate**

■ = OFF □ = ON ▒ = Not Applicable

Rotary Switch	Setpoint Switch (S2.#)							
Position	1	2	3	4	5	6	7	8
S3.5	▒	▒	▒	▒	▒	▒	▒	▒

OFF = Disabled

ON = Enabled

**Energy Resolution**

■ = OFF □ = ON ▒ = Not Applicable

Rotary Switch	Setpoint Switch (S2.#)							
Position	1	2	3	4	5	6	7	8
S3.5	▒	▒	▒	▒	▒	▒	▒	▒

OFF = Kilo Units

ON = Mega Units

**Var/Power Factor Sign Convention**

■ = OFF □ = ON ▒ = Not Applicable

Rotary Switch	Setpoint Switch (S2.#)							
Position	1	2	3	4	5	6	7	8
S3.5	▒	▒	▒	▒	▒	▒	▒	▒

OFF = negative sign convention

ON = positive sign convention

Pressing & Holding S1 causes all 8 switches on S2 to be saved according to the Rotary Switch S3. Always set all 8 S2 switches. See Figure 2.2 (p.4) and Table 5.A (p.21).

**INCOM Programmable**

■ = OFF   □ = ON   ▒ = Not Applicable

Rotary Switch	Setpoint Switch (S2.#)								
	Position	1	2	3	4	5	6	7	8
S3.C	▒	▒	▒	▒	▒	▒	▒	▒	▒

OFF = Disabled

ON = Enabled

**DP-4000/DP-2 Mode**

■ = OFF   □ = ON   ▒ = Not Applicable

Rotary Switch	Setpoint Switch (S2.#)								
	Position	1	2	3	4	5	6	7	8
S3.C	▒	▒	▒	▒	▒	▒	▒	▒	▒

OFF = DP2 Mode

ON = DP-4000 Mode

## Alarm 1 Setpoint Record Sheet

Pressing & Holding S1 causes all 8 switches on S2 to be saved according to the Rotary Switch S3. Always set all 8 S2 switches. See Figure 2.2 (p.4) and Table 5.A (p.21).

### Alarm 1 Mode 1/Mode 2

■ = OFF   □ = ON   ▒ = Not Applicable

Rotary Switch	Setpoint Switch (S2.#)							
Position	1	2	3	4	5	6	7	8
S3.6								

OFF = Mode 1

ON = Mode 2

### Alarm 1 Latched/Unlatched

■ = OFF   □ = ON   ▒ = Not Applicable

Rotary Switch	Setpoint Switch (S2.#)							
Position	1	2	3	4	5	6	7	8
S3.6								

OFF = Unlatched

ON = Latched

### Alarm 1 Activate on Overvoltage

■ = OFF   □ = ON   ▒ = Not Applicable

Rotary Switch	Setpoint Switch (S2.#)							
Position	1	2	3	4	5	6	7	8
S3.6								

OFF = Disabled

ON = Enabled

### Alarm 1 Activate on Undervoltage

■ = OFF   □ = ON   ▒ = Not Applicable

Rotary Switch	Setpoint Switch (S2.#)							
Position	1	2	3	4	5	6	7	8
S3.6								

OFF = Disabled

ON = Enabled

### Alarm 1 Activate on Voltage Phase Loss

■ = OFF   □ = ON   ▒ = Not Applicable

Rotary Switch	Setpoint Switch (S2.#)							
Position	1	2	3	4	5	6	7	8
S3.6								

OFF = Disabled

ON = Enabled

### Alarm 1 Activate on Voltage Phase Unbalance

■ = OFF   □ = ON   ▒ = Not Applicable

Rotary Switch	Setpoint Switch (S2.#)							
Position	1	2	3	4	5	6	7	8
S3.6								

OFF = Disabled

ON = Enabled

Pressing & Holding S1 causes all 8 switches on S2 to be saved according to the Rotary Switch S3. Always set all 8 S2 switches. See Figure 2.2 (p.4) and Table 5.A (p.21).

**Alarm 1 Activate on Voltage Phase Reversal**

■ = OFF □ = ON ■ = Not Applicable

Rotary Switch	Setpoint Switch (S2.#)							
Position	1	2	3	4	5	6	7	8
S3.6	■	■	■	■	■	■	■	■

OFF = Disabled

ON = Enabled

**Alarm 1 Activate on Current Phase Loss**

■ = OFF □ = ON ■ = Not Applicable

Rotary Switch	Setpoint Switch (S2.#)							
Position	1	2	3	4	5	6	7	8
S3.6	■	■	■	■	■	■	■	■

OFF = Disabled

ON = Enabled

**Alarm 1 Enable/Disable**

■ = OFF □ = ON ■ = Not Applicable

Rotary Switch	Setpoint Switch (S2.#)							
Position	1	2	3	4	5	6	7	8
S3.8	■	■	■	■	■	■	■	■

OFF = Disabled

ON = Enabled

**Alarm 1 Trip Delay**

■ = OFF □ = ON ■ = Not Applicable

Rotary Switch	Setpoint Switch (S2.#)							
Position	1	2	3	4	5	6	7	8
S3.8	■	■	■	■	■	■	■	■

See Table 5.R

**Alarm 1 Reset Delay**

■ = OFF □ = ON ■ = Not Applicable

Rotary Switch	Setpoint Switch (S2.#)							
Position	1	2	3	4	5	6	7	8
S3.8	■	■	■	■	■	■	■	■

See Table 5.S

**Alarm 1 Overvoltage Detection Level**

■ = OFF □ = ON ■ = Not Applicable

Rotary Switch	Setpoint Switch (S2.#)							
Position	1	2	3	4	5	6	7	8
S3.8	■	■	■	■	■	■	■	■
S3.9	■	■	■	■	■	■	■	■

See Table 5.T

Pressing & Holding S1 causes all 8 switches on S2 to be saved according to the Rotary Switch S3. Always set all 8 S2 switches. See Figure 2.2 (p.4) and Table 5.A (p.21).

**Alarm 1 Undervoltage Detection Level**

■ = OFF □ = ON ■ = Not Applicable

Rotary Switch		Setpoint Switch (S2.#)							
Position	1	2	3	4	5	6	7	8	
S3.9	■	■	□	□	□	■	■	■	

See Table 5.U

**Alarm 1 Voltage Phase Unbalance Detection Level**

■ = OFF □ = ON ■ = Not Applicable

Rotary Switch		Setpoint Switch (S2.#)							
Position	1	2	3	4	5	6	7	8	
S3.9	■	■	■	■	■	□	□	□	

See Table 5.V

**Alarm 1 Reset Threshold**

■ = OFF □ = ON ■ = Not Applicable

Rotary Switch		Setpoint Switch (S2.#)							
Position	1	2	3	4	5	6	7	8	
S3.C	□	□	□	■	■	■	■	■	

See Table 5.W

## Alarm 2 Setpoint Record Sheet

Pressing & Holding S1 causes all 8 switches on S2 to be saved according to the Rotary Switch S3. Always set all 8 S2 switches. See Figure 2.2 (p.4) and Table 5.A (p.21).

### Alarm 2 Mode 1/Mode 2

■ = OFF   □ = ON   ■ = Not Applicable

Rotary Switch	Setpoint Switch (S2.#)							
Position	1	2	3	4	5	6	7	8
S3.7								

OFF = Mode 1

ON = Mode 2

### Alarm 2 Latched/Unlatched

■ = OFF   □ = ON   ■ = Not Applicable

Rotary Switch	Setpoint Switch (S2.#)							
Position	1	2	3	4	5	6	7	8
S3.7								

OFF = Unlatched

ON = Latched

### Alarm 2 Activate on Overvoltage

■ = OFF   □ = ON   ■ = Not Applicable

Rotary Switch	Setpoint Switch (S2.#)							
Position	1	2	3	4	5	6	7	8
S3.7								

OFF = Disabled

ON = Enabled

### Alarm 2 Activate on Undervoltage

■ = OFF   □ = ON   ■ = Not Applicable

Rotary Switch	Setpoint Switch (S2.#)							
Position	1	2	3	4	5	6	7	8
S3.7								

OFF = Disabled

ON = Enabled

### Alarm 2 Activate on Voltage Phase Loss

■ = OFF   □ = ON   ■ = Not Applicable

Rotary Switch	Setpoint Switch (S2.#)							
Position	1	2	3	4	5	6	7	8
S3.7								

OFF = Disabled

ON = Enabled

### Alarm 2 Activate on Voltage Phase Unbalance

■ = OFF   □ = ON   ■ = Not Applicable

Rotary Switch	Setpoint Switch (S2.#)							
Position	1	2	3	4	5	6	7	8
S3.7								

OFF = Disabled

ON = Enabled



Pressing & Holding S1 causes all 8 switches on S2 to be saved according to the Rotary Switch S3. Always set all 8 S2 switches. See Figure 2.2 (p.4) and Table 5.A (p.21).

**Alarm 2 Activate on Voltage Phase Reversal**

■ = OFF □ = ON ■ = Not Applicable

Rotary Switch	Setpoint Switch (S2.#)							
Position	1	2	3	4	5	6	7	8
S3.7								

OFF = Disabled

ON = Enabled

**Alarm 2 Activate on Current Phase Loss**

■ = OFF □ = ON ■ = Not Applicable

Rotary Switch	Setpoint Switch (S2.#)							
Position	1	2	3	4	5	6	7	8
S3.7								

OFF = Disabled

ON = Enabled

**Alarm 2 Enable/Disable**

■ = OFF □ = ON ■ = Not Applicable

Rotary Switch	Setpoint Switch (S2.#)							
Position	1	2	3	4	5	6	7	8
S3.A								

OFF = Disabled

ON = Enabled

**Alarm 2 Trip Delay**

■ = OFF □ = ON ■ = Not Applicable

Rotary Switch	Setpoint Switch (S2.#)							
Position	1	2	3	4	5	6	7	8
S3.A								

See Table 5.R

**Alarm 2 Reset Delay**

■ = OFF □ = ON ■ = Not Applicable

Rotary Switch	Setpoint Switch (S2.#)							
Position	1	2	3	4	5	6	7	8
S3.A								

See Table 5.S

**Alarm 2 Overvoltage Detection Level**

■ = OFF □ = ON ■ = Not Applicable

Rotary Switch	Setpoint Switch (S2.#)							
Position	1	2	3	4	5	6	7	8
S3.A								
S3.B								

See Table 5.T

Pressing & Holding S1 causes all 8 switches on S2 to be saved according to the Rotary Switch S3. Always set all 8 S2 switches. See Figure 2.2 (p.4) and Table 5.A (p.21).

**Alarm 2 Undervoltage Detection Level**

■ = OFF □ = ON ■ = Not Applicable

Rotary Switch	Setpoint Switch (S2.#)							
Position	1	2	3	4	5	6	7	8
S3.B	■	■	□	□	□	■	■	■

See Table 5.U

**Alarm 2 Voltage Phase Unbalance Detection Level**

■ = OFF □ = ON ■ = Not Applicable

Rotary Switch	Setpoint Switch (S2.#)							
Position	1	2	3	4	5	6	7	8
S3.B	■	■	■	■	■	□	□	□

See Table 5.V

**Alarm 2 Reset Threshold**

■ = OFF □ = ON ■ = Not Applicable

Rotary Switch	Setpoint Switch (S2.#)							
Position	1	2	3	4	5	6	7	8
S3.C	■	■	■	□	□	□	■	■

See Table 5.W

## Optional I/O Setpoint Record Sheet

Pressing & Holding S1 causes all 8 switches on S2 to be saved according to the Rotary Switch S3. Always set all 8 S2 switches. See Figure 2.2 (p.4) and Table 5.A (p.21).

### Discrete Input Setup

■ = OFF   □ = ON   ▒ = Not Applicable

Rotary Switch	Setpoint Switch (S2.#)							
Position	1	2	3	4	5	6	7	8
S3.5								

OFF = Input is used as a Sync Pulse

ON = Input is used as an External Reset

### Sync Pulse

■ = OFF   □ = ON   ▒ = Not Applicable

Rotary Switch	Setpoint Switch (S2.#)							
Position	1	2	3	4	5	6	7	8
S3.5								

OFF = Sync Pulse is from discrete input

ON = Demand window is timed internally

### Pulse Initiator/Load Shed

■ = OFF   □ = ON   ▒ = Not Applicable

Rotary Switch	Setpoint Switch (S2.#)							
Position	1	2	3	4	5	6	7	8
S3.D								

OFF = Relay acts as pulse initiator

ON = Relay acts as load shed

### Pulse Initiator Parameter

■ = OFF   □ = ON   ▒ = Not Applicable

Rotary Switch	Setpoint Switch (S2.#)							
Position	1	2	3	4	5	6	7	8
S3.D								

See Table 5.X

### Load Shed Range

■ = OFF   □ = ON   ▒ = Not Applicable

Rotary Switch	Setpoint Switch (S2.#)							
Position	1	2	3	4	5	6	7	8
S3.E								
S3.D								

See Table 5.Y

### Restore Load

■ = OFF   □ = ON   ▒ = Not Applicable

Rotary Switch	Setpoint Switch (S2.#)							
Position	1	2	3	4	5	6	7	8
S3.E								
S3.D								

See Table 5.Y

Pressing & Holding S1 causes all 8 switches on S2 to be saved according to the Rotary Switch S3. Always set all 8 S2 switches. See Figure 2.2 (p.4) and Table 5.A (p.21).

**Load Shed Parameter**

■ = OFF   □ = ON   ▒ = Not Applicable

Rotary Switch	Setpoint Switch (S2.#)							
Position	1	2	3	4	5	6	7	8
S3.F					▒	▒	▒	▒

See Table 5.Z

**Pulse Initiator Rate**

■ = OFF   □ = ON   ▒ = Not Applicable

Rotary Switch	Setpoint Switch (S2.#)							
Position	1	2	3	4	5	6	7	8
S3.F	▒	▒	▒	▒				

See Table 5.AA

***IQ DP-4000 User Manual  
Customer Comments***

Did you find any corrections that need to be made to this manual?  
(Please include the page number.)

---

---

---

Were any parts of the manual unclear? Do you require further detail or description? (Please list parts.)

---

---

---

What are your special application needs?

---

---

---

As part of a constant effort to serve your needs, we are interested in any information you can supply about your application or use of the IQ DP-4000. If you would like to share this information, please check the box below.

Please call me to discuss my use of the IQ DP-4000.

Name \_\_\_\_\_ Title \_\_\_\_\_  
Company \_\_\_\_\_ Phone \_\_\_\_\_  
Street and Number \_\_\_\_\_  
City \_\_\_\_\_ State \_\_\_\_\_ ZIP \_\_\_\_\_

**Information Request**

Please send me updated application materials when available.

Please send me information on

---

Please have a Sales Engineer call.

Please contact me to discuss PowerNet Local Area Network applications.

Name \_\_\_\_\_ Title \_\_\_\_\_  
Company \_\_\_\_\_ Phone \_\_\_\_\_  
Street and Number \_\_\_\_\_  
City \_\_\_\_\_ State \_\_\_\_\_ ZIP \_\_\_\_\_

**8793C50H03**

PLACE  
STAMP  
HERE

**Cutler-Hammer**

Power Management Products Center  
240 Vista Park Drive  
Pittsburgh, PA 15205

**ATTN: IQ Metering and Protection Marketing**