

**Dalkeith High School  
Higher Human Biology  
Homework 3**

1. A DNA molecule consists of 4000 nucleotides of which 20% contain the base adenine.

How many of the nucleotides in this DNA molecule will contain guanine?

- A** 800  
**B** 1000  
**C** 1200  
**D** 1600
2. The function of tRNA in cell metabolism is to
- A** transport amino acids to be used in synthesis  
**B** carry codons to the ribosomes  
**C** synthesise proteins  
**D** transcribe the DNA code
3. A fragment of DNA was found to have 120 guanine bases and 60 adenine bases. What is the total number of sugar molecules in this fragment?
- A.** 60  
**B.** 90  
**C.** 180  
**D.** 360
4. If ten percent of the bases in a molecule of DNA are adenine, what is the ratio of adenine to guanine in the same molecule?
- A.** 1:1  
**B.** 1:2  
**C.** 1:3  
**D.** 1:4

5. The following information refers to protein synthesis.

<i>tRNA anticodon</i>	<i>amino acid carried by tRNA</i>
G U G	Histidine (his)
C G U	Alanine (ala)
G C A	Argomome (arg)
A U G	Tyrosine (tyr)
U A C	Methionine (met)
U G U	Threonine (thr)

What order of amino acids would be synthesised from the base sequence of DNA shown?

*Base sequence of DNA*

C G T T A C G T G

- A** arg - tyr - his  
**B** ala - met - his  
**C** ala - tyr - his  
**D** arg - tyr - thr
6. The table below contains statements which may be **TRUE** or **FALSE** with regard to DNA replication and mRNA synthesis.

Which line in the table is correct?

	<i>Statement</i>	<i>DNA Replication</i>	<i>mRNA synthesis</i>
<b>A</b>	Occurs in the nucleus	<b>TRUE</b>	<b>FALSE</b>
<b>B</b>	Involved in protein synthesis	<b>TRUE</b>	<b>TRUE</b>
<b>C</b>	Requires free nucleotides	<b>TRUE</b>	<b>FALSE</b>
<b>D</b>	Involves specific base pairing	<b>TRUE</b>	<b>TRUE</b>

7. The diagram represents part of a molecule of DNA on which a molecule of RNA is being synthesised.

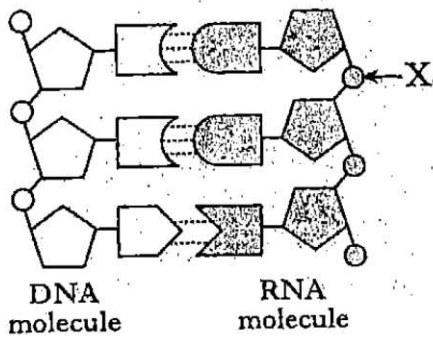

What does component X represent?

- A Ribose sugar
  - B Deoxyribose sugar
  - C Phosphate
  - D Ribose phosphate
8. DNA controls the activities of a cell by coding for the production of
- A proteins
  - B carbohydrates
  - C amino acids
  - D bases
9. A DNA nucleotide could be formed from a molecule of phosphate together with
- A. Ribose sugar and guanine
  - B. Ribose sugar and uracil
  - C. Deoxyribose sugar and uracil
  - D. Deoxyribose sugar and uracil
10. If a DNA molecule contains 8000 nucleotides of which 20% are adenine, then the number of guanine nucleotides present is:
- A 1600
  - B 2000
  - C 2400
  - D 3200

11. The diagram shows a stage in the synthesis of part of a polypeptide.

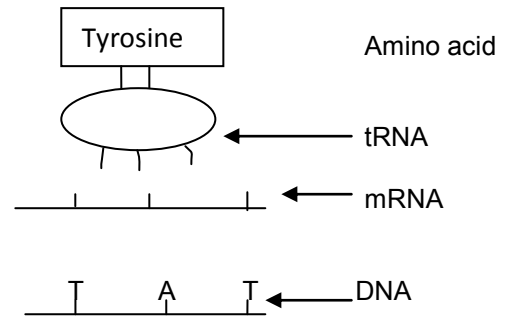

Identify the triplet codes for the amino acid tyrosine.

	<i>mRNA</i>	<i>tRNA</i>
<b>A</b>	ATA	UAU
<b>B</b>	UAU	AUA
<b>C</b>	AUA	UAU
<b>D</b>	ATA	TAT

12. The base sequence of a short piece of DNA is shown below

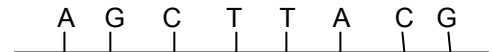

During replication, an inversion mutation occurred on the complementary strand synthesised on this piece of DNA.

- A. T C G A A T G A
- B. A G C T T A G C
- C. T C G A A T C G
- D. T C G A A T G C

**13.** During the polymerase chain reaction (PCR) samples of DNA are repeatedly heated and cooled.

Why are the samples cooled?

- A** To denature DNA polymerase
- B** To slow the reaction down
- C** To allow primers to bind to target sequences
- D** To separate the DNA strands

**14.** What is the function of a DNA probe?

- A** To replicate a particular region of DNA
- B** To join fragments of DNA together
- C** To remove non-coding sections of DNA
- D** To detect the presence of specific DNA Sequences

**15.** The diagram below shows the results of a paternity test. It compares DNA samples from five individuals.

Woman S is the mother of child X and child Y. Men P and Q are possible fathers of these children.

Woman S	Man P	Man Q	Child X	Child Y
—	—	—	—	—
—	—	—	—	—
—	—	—	—	—
—	—	—	—	—
—	—	—	—	—
—	—	—	—	—
—	—	—	—	—
—	—	—	—	—
—	—	—	—	—

Which of the following conclusions can be drawn from these results?

- A** Man P could be the father of child X
- B** Man P could be the father of child Y
- C** Man Q could be the father of child X
- D** Man Q could be the father of child Y

**16.** The table below refers to the mass of DNA in certain human body cells.

Cell type	Mass of DNA in cell ( $\times 10^{-12}g$ )
liver	6.6
Lung	6.6
P	3.3
Q	0.0

Which of the following is most likely to identify correctly cell types P and Q?

	P	Q
A	Kidney cell	Sperm cell
B	Sperm cell	Mature red blood cell
C	Mature red blood cell	Sperm cell
D	Nerve cell	Mature red blood cell

**17.** How many adenine molecules are present in a DNA molecule of 4000 bases, if 20% of the base molecules are cytosine?

- A** 400
- B** 600
- C** 800
- D** 1200

**18.** Which of the following statements about DNA replication is correct?

- A** Polymerase adds nucleotides to the 3' end of a DNA strand
- B** Polymerase adds nucleotides to the 5' end of a DNA strand
- C** Ligase adds nucleotides to the 3' end of a DNA strand
- D** Ligase adds nucleotides to the 5' end of a DNA Strand

19. The family tree below shows the transmission of the Rhesus D-antigen through three generations of a family. The allele coding for the presence of the Rhesus D-antigen is dominant and autosomal.

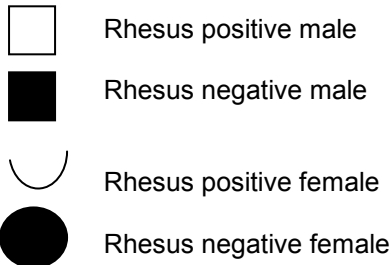
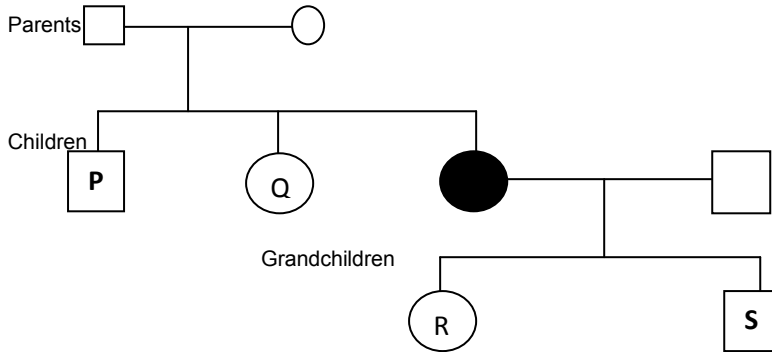

Which of the children and grandchildren in the family tree must be heterozygous?

- A P, Q, R and S  
 B P and Q only  
 C R and S only  
 D Q and R only

20. The table below shows some genotypes and phenotypes associated with a form of anaemia

Genotype	Phenotype
AA	Unaffected
AS	Sickle cell trait
SS	Acute sickle cell anaemia

An unaffected person and someone with sickle cell trait have a child together.

What are the chances of the child having acute sickle cell anaemia?

- A none  
 B 1 in 4  
 C 1 in 2  
 D 1 in 1

21. The family tree shows the pattern of inheritance of a genetic condition.

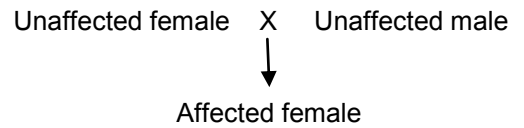

The allele responsible for this condition is both

- A sex-linked and recessive  
 B sex-linked and dominant  
 C autosomal and recessive  
 D autosomal and dominant
22. Non-disjunction can be described as
- A a metabolic disorder  
 B a type of antisocial behaviour  
 C a condition resulting in memory loss  
 D a form of chromosome mutation
23. Haemophilia is a sex-linked recessive condition. A woman, who does not have this condition, has a haemophiliac son. The boy's father is also a haemophiliac.

What are the genotypes of the parents?

	Father	Mother
A	$X^H Y$	$X^H X^h$
B	$X^h Y$	$X^h X^h$
C	$X^h Y$	$X^H X^H$
D	$X^h Y$	$X^H X^h$

24. A substitution mutation results in a triplet of bases TTC being changed to Tcc. The amino acid lysine is coded for by TTC and arginine by TCC.

- A arginine replaces lysine throughout the Protein  
 B arginine replaces lysine at one position in the protein  
 C lysine replaces arginine throughout the protein  
 D lysine replaces arginine at one position in the protein

25. Which type of gene mutation occurs when a codon for an amino acid is replaced by a stop codon?

- A Nonsense
- B Missense
- C Frameshift
- D Splice-site

26. Individuals with Cri-du-chat syndrome have a shortened chromosome 5.

No other chromosomes are affected

Which type of mutation causes Cri-du-chat syndrome?

- A Deletion
- B Insertion
- C Duplication
- D Translocation

27. Huntington's Disease is an inherited condition in humans caused by a dominant allele which is not sex-linked.

A woman's father is heterozygous for the condition and her mother is unaffected.

What is the chance of the woman having the condition?

- A 1 in 1
- B 1 in 2
- C 1 in 3
- D 1 in 4

28. A sex-linked condition in humans is caused by a recessive allele. What is the chance of an unaffected man and a carrier woman having an unaffected male child?

- A 1 in 1
- B 1 in 2
- C 1 in 3
- D 1 in 4

29. Thirty percent of bases in a DNA molecule are adenine. The percentage of cytosine bases in the same molecule is

- A 20%
- B 30%
- C 40%
- D 70%

30. Phenylketonuria (PKU) is a metabolic disorder which can be lethal in childhood. It is caused by an inability to make *enzyme X*, shown in the metabolic pathway below.

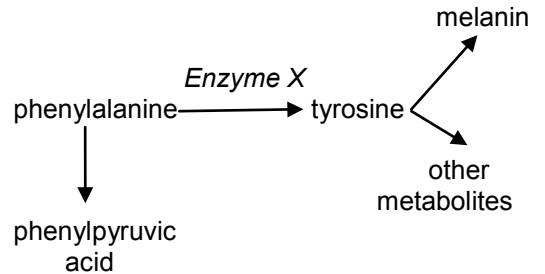

Which substance would have to be removed from the diet for someone who has this disorder?

- A Phenylalanine
- B Enzyme X
- C Tyrosine
- D Melanin

31. Cystic fibrosis is a genetic condition caused by an allele which is not sex-linked.

A child is born with cystic fibrosis despite neither parent having the condition.

The parents are going to have a second child. What is the chance this child will have cystic fibrosis?

- A. 1 in 2
- B. 1 in 3
- C. 1 in 4
- D. None

32. If the mass of DNA in a human liver cell is  $6.6 \times 10^{-12}$ g, the mass of DNA in a human sperm is likely to be

- A  $3.3 \times 10^{-6}$ g
- B  $3.3 \times 10^{-12}$ g
- C  $6.6 \times 10^{-6}$ g
- D  $6.6 \times 10^{-12}$ g

33. A section of DNA has the following base sequence



Identify the anti-codons of the three tRNA molecules which would align with the mRNA molecule transcribed from this section of DNA.

- A AAU CGC UUC
- B AAT CGC TTC
- C TTA GCG AAG
- D UUA GCG AAG

34. Which of the following diagrams correctly represents part of a DNA molecule?  
The letters A, T, U, C and G represent bases.

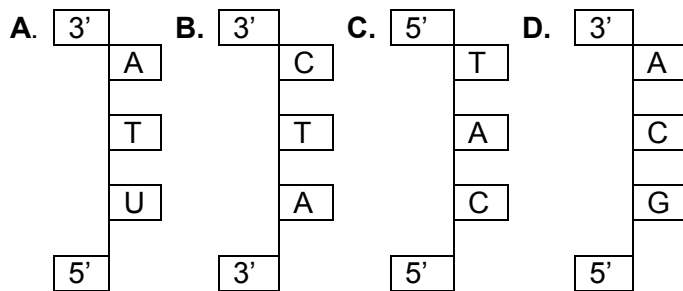

35. The two components which make up the backbone of each DNA strand are

- A Ribose and phosphate group      C Deoxyribose and base pairs  
B Deoxyribose and phosphate group      D Phosphate group and thymine

36. Which of the following statements about the structure of DNA is **TRUE**?

- A. In DNA the base pairs are held together by peptide bonds.  
B. Fragments of DNA are joined together by polymerase  
C. Fragments of DNA are joined together by polymerase  
D. DNA contains the bases represented by the letters A, U, C and G.

37. In Duchenne Muscular Dystrophy (DMD) one amino acid codon is substituted with a stop codon.

- A. Missense      B. nonsense      C. frameshift      D. splice-site

38. In cystic fibrosis (CF) one base pair is deleted. This is an example of

- A. Missense      B. nonsense      C. frameshift      D. splice-site

39. Which of the following lines regarding DNA amplification is **TRUE**?

	<b>Melting</b>	<b>Annealing</b>	<b>Extending</b>
<b>A.</b>	Heating the DNA to separate the strands	Primers bind at two ends of the region to be amplified	Complementary strands of target DNA are made
<b>B.</b>	Complementary strands of target DNA are made	Heating the DNA to separate the strands	Primers bind at two ends of the region to be amplified
<b>C.</b>	Primers bind at two ends of the region to be amplified	Heating the DNA to separate the strands	Complementary strands of target DNA are made
<b>D.</b>	Heating the DNA to separate the strands	Complementary strands of target DNA are made	Primers bind at two ends of the region to be amplified

**40.** How many cycles have been completed if 128 molecules of DNA were produced from one double DNA helix?

- A.** 5      **B.** 6      **C.** 7      **D.** 8

**41.** The mRNA codon for the amino acid threonine is ACU. What is the corresponding anti-codon?

- A.** ACT      **B.** UCT      **C.** UGA      **D.** TGA

**SECTION B**

**All questions in this section should be attempted.  
All answers must be written clearly and legibly in ink.**

1. The diagram below shows part of a DNA molecule.

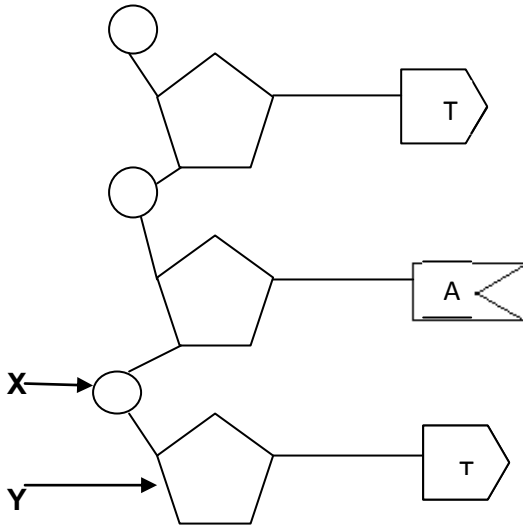

1

(a) (i) On the diagram, draw a circle around **one** nucleotide.

(ii) Name parts X and Y

X \_\_\_\_\_

Y \_\_\_\_\_

1

(b) Name the **two** DNA bases **not** shown in the diagram.

\_\_\_\_\_ and \_\_\_\_\_ 1

(c) (i) State the mRNA codon which would be formed from the triplet of DNA bases shown

(ii) Apart from nucleotides, name another molecule needed for the synthesis of mRNA.

\_\_\_\_\_ 1

(d) A DNA molecule was found to contain 15000 nucleotides.

What is the maximum number of amino acids which could be coded for by this molecule?

\_\_\_\_\_ 1



2. The diagram below illustrates the two main stages of protein synthesis.

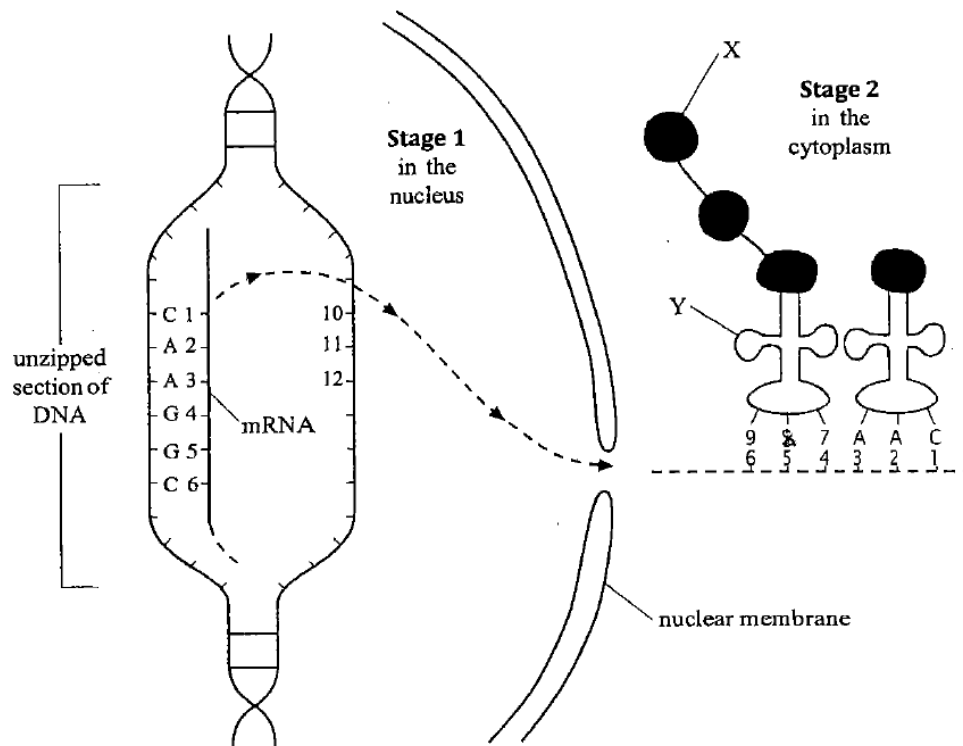

(a) Describe **three** differences between DNA and mRNA.

1. \_\_\_\_\_  
 \_\_\_\_\_  
 \_\_\_\_\_
2. \_\_\_\_\_  
 \_\_\_\_\_  
 \_\_\_\_\_
3. \_\_\_\_\_  
 \_\_\_\_\_

2. (Continued)

(b) Name bases 3, 8 and 11.

Base 3 \_\_\_\_\_

Base 8 \_\_\_\_\_

Base 11 \_\_\_\_\_

2

(c) Circle a codon in the diagram opposite.

1

(d) Where in the cytoplasm does stage 2 take place

\_\_\_\_\_

1

(e) Name molecules X and Y.

X \_\_\_\_\_ Y \_\_\_\_\_ 1

(f) The newly synthesised protein may be secreted from the cell.

(i) Name the cell structure where the protein would be found just before it enters a secretory vesicle.

\_\_\_\_\_

1

(ii) Describe what happens to the protein while it is in this cell structure.

\_\_\_\_\_

1

3. (a) The diagram shows part of an mRNA molecule being formed on a strand of DNA.

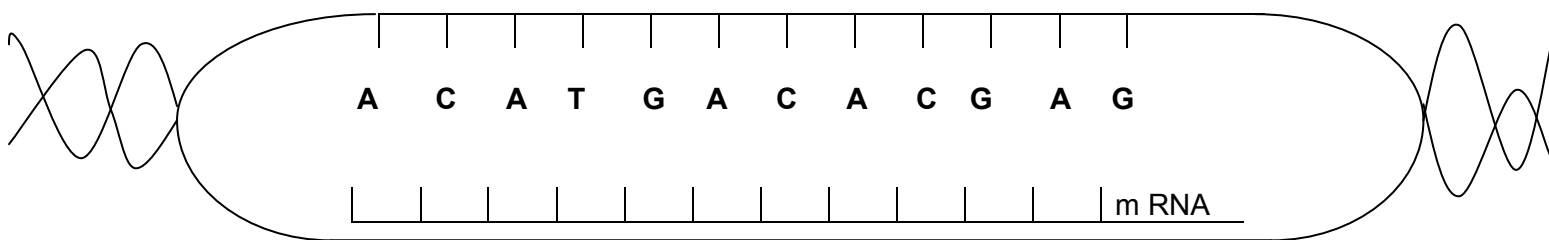

(i) In which part of the cell is mRNA formed?

\_\_\_\_\_

1

(ii) Complete the mRNA molecule by filling in the correct base sequence on the diagram.

(iii) How many amino acids are coded for by this section of mRNA?

\_\_\_\_\_

1

4. (a) The diagram below shows a section of a messenger RNA (mRNA) molecule.

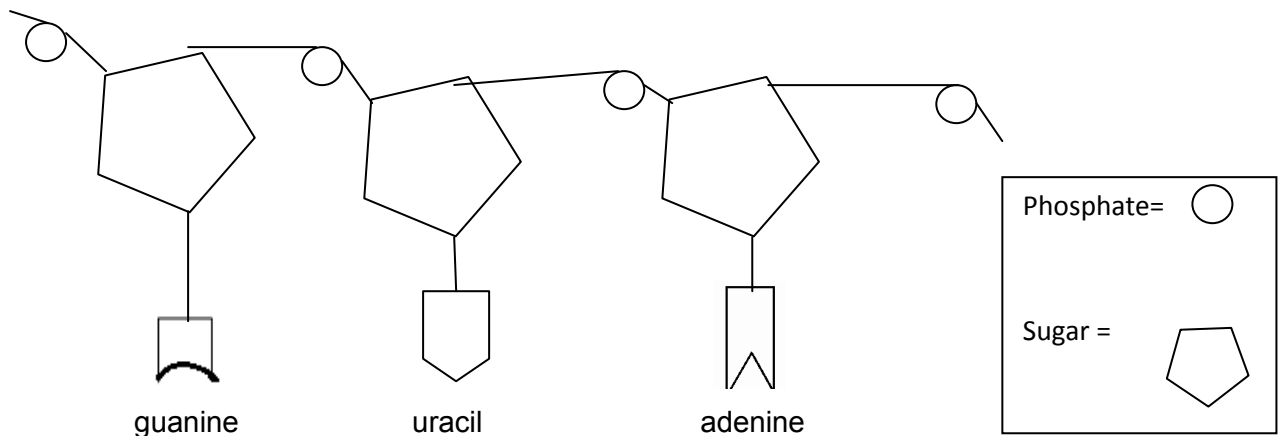

(i) Name the sugar that is present in mRNA

\_\_\_\_\_

1

(ii) Which base found in mRNA is **not** shown in the diagram?

\_\_\_\_\_

(iii) Name **two** parts of a cell where mRNA is found.

1. \_\_\_\_\_

2. \_\_\_\_\_

1

(b) DNA templates are used to produce mRNA molecules.

(i) Insert the names of the DNA bases which pair with the RNA bases shown in the table below.

<i>DNA base</i>	<i>RNA base</i>
	Adenine
	Uracil
	guanine

1

(ii) Apart from free RNA nucleotides and a DNA template, name **one** other molecule that is essential for mRNA synthesis.

\_\_\_\_\_

1

(iii) Describe the part played by an mRNA molecule in the manufacture of a cell protein.

\_\_\_\_\_

\_\_\_\_\_

3

5. The formation of a mRNA strand on a section of a chromosome is shown in the diagram below.

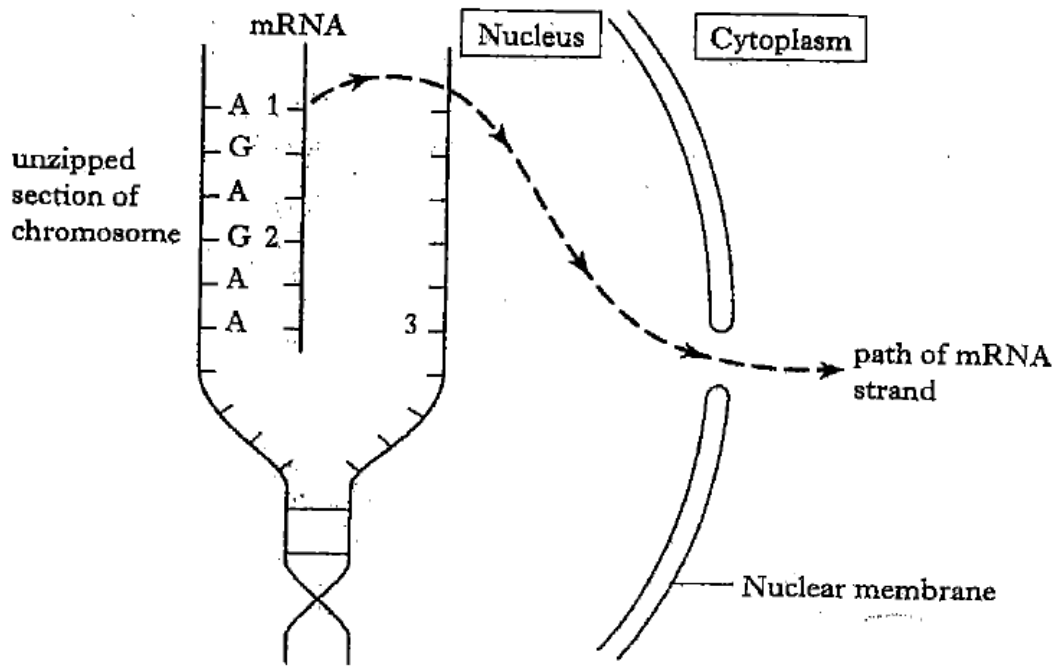

- (a) Give the names of bases 1, 2 and 3.

1. \_\_\_\_\_ 2. \_\_\_\_\_ 3. \_\_\_\_\_ 1

- (b) The mRNA strand is constructed from free nucleotides.  
Name the **two** molecules which combine with a base to form a mRNA nucleotide.

1. \_\_\_\_\_ 2. \_\_\_\_\_ 1

- (c) Once completed, the mRNA strand moves into the cytoplasm.  
What is its destination?

\_\_\_\_\_ 1

- (d) Explain why the formation of mRNA strands is essential to cell metabolism.

\_\_\_\_\_  
\_\_\_\_\_  
\_\_\_\_\_

**2**

6. The diagram shows the synthesis of a peptide chain.

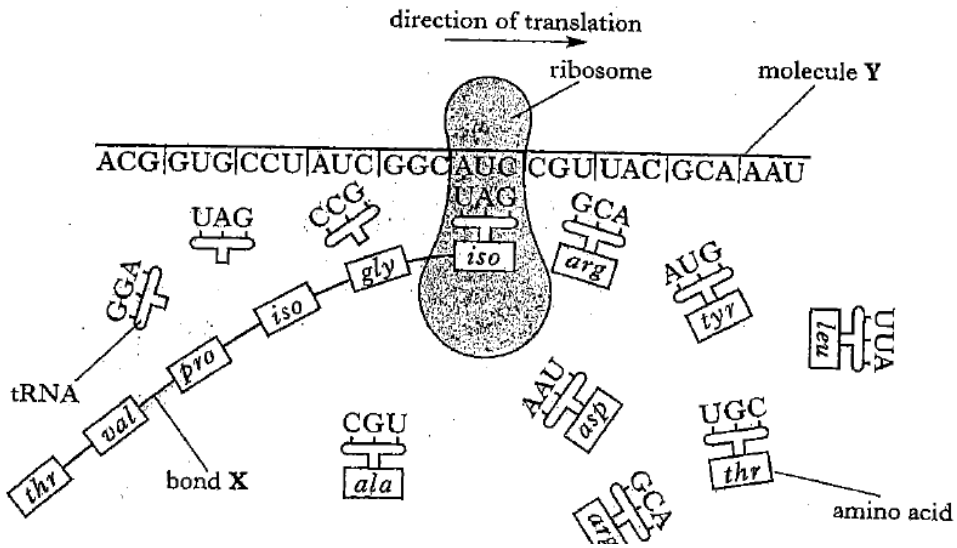

(a) Name bond X and molecule Y.

Bond X \_\_\_\_\_ Molecule Y \_\_\_\_\_

2

(b) What term is used to describe the triplet code on the tRNA molecules?

\_\_\_\_\_

1

(c) Give the abbreviated names of the next four amino acids which will be attached to complete the peptide chain.

*iso*  
 \_\_\_\_\_ → \_\_\_\_\_ → \_\_\_\_\_ → \_\_\_\_\_ → \_\_\_\_\_

1

(d) What sequence of bases on a DNA molecule will code for the amino acid labelled *thr*?

\_\_\_\_\_

1

(e) Amino acids are added to the peptide chain at the rate of 15 per second.

How long will it take for the complete synthesis of the peptide shown in the diagram above?

\_\_\_\_\_ s

1

7. The diagram below shows a section through a nucleus and associated cell structures.

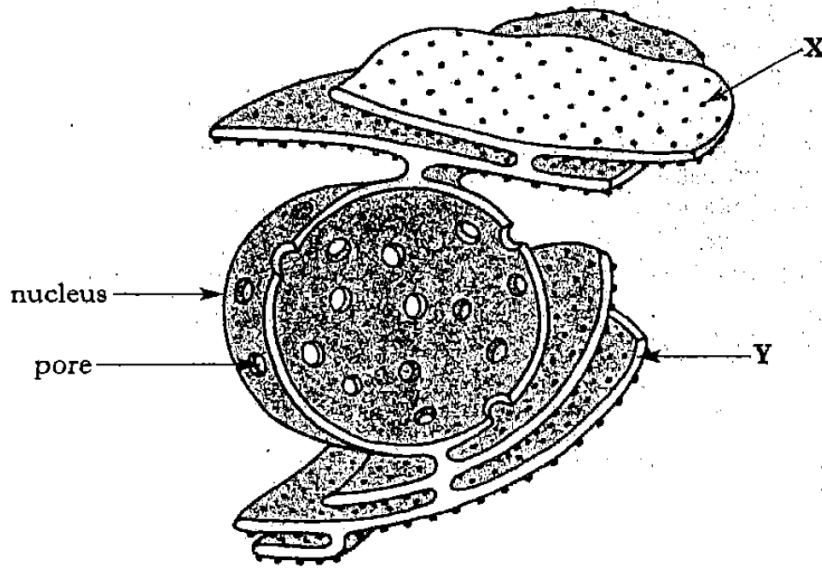

(a) (i) Name organelle X.

\_\_\_\_\_

1

(ii) What type of substance is manufactured by organelle X?

\_\_\_\_\_

1

(iii) Give an example of such a substance.

\_\_\_\_\_

1

(b) (i) The structure Y can transport substances to another organelle within the cell.

Give an example of such an organelle and state its function.

Example \_\_\_\_\_

1

Function \_\_\_\_\_

1

(c) Why is it necessary to have pores in the nuclear membrane?

\_\_\_\_\_

\_\_\_\_\_

1

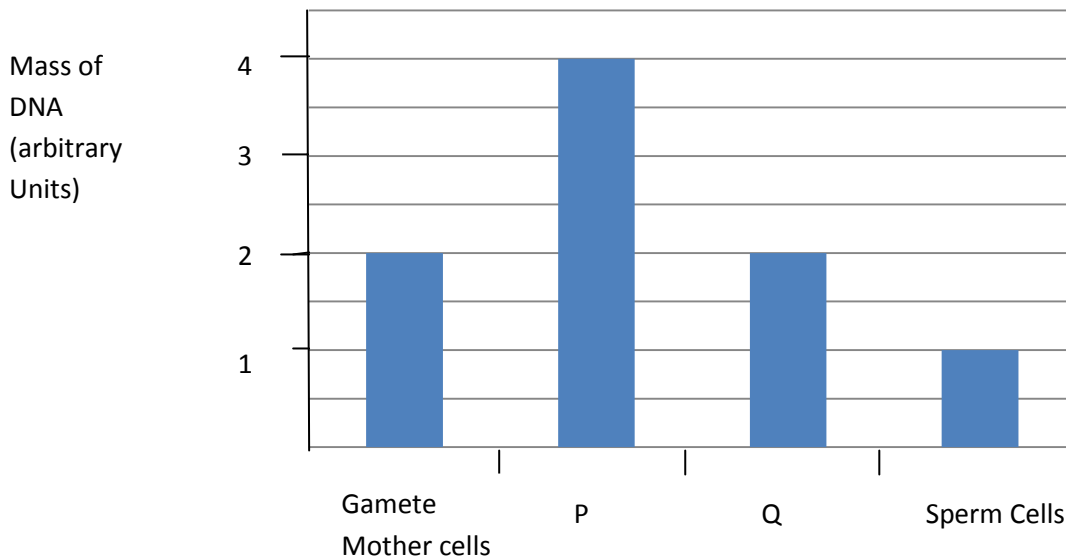

8. The graph below show the mass of DNA present as gamete mother cells develop into sperm cells during meiosis in the testes. P and Q represent cells at intermediate stages in this process.



- (a) Explain why the mass of DNA changes between
- (i) the gamete mother cells and cell type P \_\_\_\_\_  
 \_\_\_\_\_ **1**
- (ii) cell types P and Q \_\_\_\_\_  
 \_\_\_\_\_ **1**
- (b) Some diseases are caused when cells in the body produce a harmful protein. Recent research has led to the development of antisense drugs to treat such diseases. These drugs carry a short strand of RNA nucleotides designed to attach to a small part of the mRNA molecule that codes for the harmful protein.
- (i) Suggest how these drugs may prevent the production of a harmful protein.  
 \_\_\_\_\_  
 \_\_\_\_\_ **1**
- (ii) Antisense drugs can be used to treat autoimmune diseases.  
 Describe what is meant by an autoimmune disease.  
 \_\_\_\_\_  
 \_\_\_\_\_ **1**

9. The diagram below shows one gene within a chromosome.



 Non coding region of the gene       coding region of the gene

(a) State what non-coding regions of a gene are called.

\_\_\_\_\_ 1

(b) Explain why it is important that non-coding regions are removed from the primary transcript of this gene before translation.

\_\_\_\_\_  
\_\_\_\_\_ 1

(c) The diagram below shows part of one coding region of the mRNA from this gene.



How many different types of amino acid are coded for by this region of the mRNA strand?

\_\_\_\_\_ 1

(d) Describe two ways in which the structure of a molecule of mRNA differs from that of DNA.

1. \_\_\_\_\_  
\_\_\_\_\_

2. \_\_\_\_\_  
\_\_\_\_\_ 2



10. Many inherited disorders are caused by inborn errors of metabolism.

(a) (i) What causes disorders that lead to inborn errors of metabolism?

\_\_\_\_\_ 1

(ii) How do these inherited disorders affect metabolic pathways?

\_\_\_\_\_  
\_\_\_\_\_ 1

(b) Phenylketonuria (PKU) is an example of an inherited disorder.

One metabolic pathway affected by PKU is shown below.

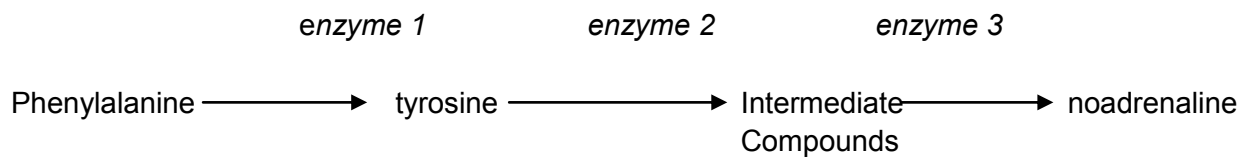

(i) Describe how PKU affects the metabolic pathway shown above.

\_\_\_\_\_  
\_\_\_\_\_ 1

(ii) With reference to the metabolic pathway shown, explain why PKU affects the nervous system.

\_\_\_\_\_  
\_\_\_\_\_  
\_\_\_\_\_  
\_\_\_\_\_ 2

(c) What term describes the testing of newborn babies for inherited disorders such as PKU?

\_\_\_\_\_ 1

11. (a) The following table shows the number of differences in the amino acid sequence for haemoglobin from three animals compared to that of human haemoglobin.

The number of differences gives an indication of evolutionary relationships between species.

<i>Animal</i>	<i>Number of differences in the haemoglobin amino acid sequence compared to human haemoglobin</i>
Frog	67
Mouse	27
Dog	32

Which of these animal's haemoglobin is most closely related to human haemoglobin?

\_\_\_\_\_ 1

- (b) What term describes all the DNA of a species?

\_\_\_\_\_ 1

12. The diagram below shows part of a metabolic pathway. Each stage is controlled by an enzyme.

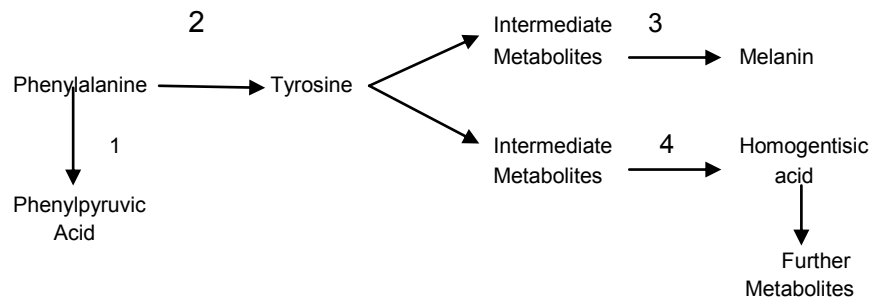

Phenylketonuria (PKU) is caused by a mutation of the gene required to make enzyme

- A 1
- B 2
- C 3
- D 4

13. The family tree shows the inheritance of a bone disorder.

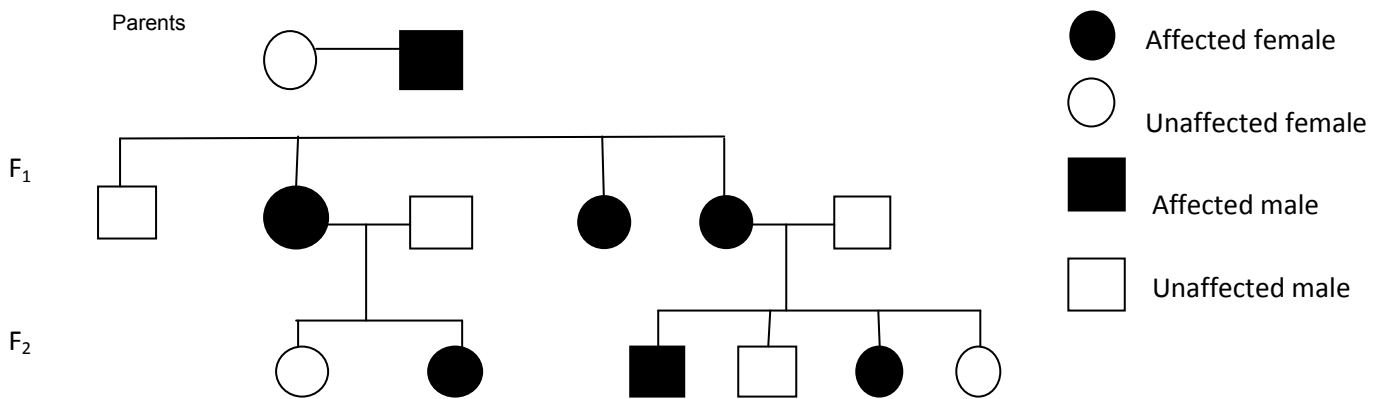

The disorder is caused by a dominant sex-linked allele (B).

(a) Using appropriate symbols, give the genotypes of individuals P, Q, R, S.

P \_\_\_\_\_ Q \_\_\_\_\_ R \_\_\_\_\_ S \_\_\_\_\_ 2

(b) (i) Explain why all the F<sub>1</sub> females in this family are affected.

\_\_\_\_\_  
 \_\_\_\_\_  
 \_\_\_\_\_ 1

(ii) Explain why only some of the F<sub>2</sub> females in this family are affected.

\_\_\_\_\_  
 \_\_\_\_\_  
 \_\_\_\_\_ 1

(c) Is the ratio of affected offspring to unaffected offspring in the F<sub>1</sub> generation As expected? Give a reason for your answer.

Yes/No \_\_\_\_\_

Reason \_\_\_\_\_

\_\_\_\_\_ 1