



**COMPONENT PROJECT ACTIVITY DESIGN DOCUMENT FORM (F-CDM-CPA-DD)
Version 02.0**

COMPONENT PROJECT ACTIVITIES DESIGN DOCUMENT (CPA-DD)

SECTION A. General description of CPA

A.1. Title of the proposed or registered PoA

Biomass residues power generation Programme

A.2. Title of the CPA

Amatikulu CPA - Renewable Energy Generation Facility

Version 1.3

24/10/2013

A.3. Description of the CPA

Amatikulu CPA consists in the installation and operation of a state-of-the art renewable energy facility and associated infrastructure at Tongaat Hulett Ltd's Amatikulu Sugar Mill, within the Umlalazi Local Municipality. The project will comprise the generation of steam electricity through high performance boilers (110 bar) and turbo-alternators (91 MW), utilising sugar cane fibre as primary fuel, complemented with cane leaves and woodchips. The excess electricity is to be exported into the South African electrical distribution grid via a new underground power line that will link up to the Amatikulu substation. Tongaat Hulett will inject 291,692 MWh (net) per year to the grid of South Africa, therefore reducing greenhouse gas emissions (CO₂) from the fossil fuel intensive grid power generation units by 269,952 tCO₂ per year.

In the baseline scenario (derived from the scenario existing prior to the implementation of Amatikulu CPA), Amatikulu Sugar Mill only burns the residual bagasse (occasionally completed with 5-10% of coal in case of bagasse supply interruption and maintenance) in a low efficiency cogeneration unit composed of 32 bar boilers and three 4 MW backpressure turbines, to cover the facilities' internal energy needs with no bagasse left-over, as the prevailing technology standard in the regional industry.

Amatikulu CPA, under the framework of the "Biomass residues power generation Programme" voluntarily coordinated by the CME, introduces renewable energy technology that is first-of-its kind in South Africa with regards to both the scale of power capacity for export and the high pressure of steam boilers. The project aims at promoting the abundant biomass residues potential in the country and improving the carbon footprint of the national electricity system in line with the Department of Energy's Renewable Energy Independent Power Producer Procurement Programme. It will involve state-of-the-art monitoring equipment and processes to be operated, maintained and calibrated by properly trained staff. Detailed description of the monitoring system is provided in the section D.7.

Contribution of the project activity to sustainable development:

Amatikulu CPA meets the South Africa Sustainable Development requirements as published by the DNA (South Africa DNA, 2004):

SD criteria	Sustainable development requirements	Amatikulu CPA characteristics
Social	Does the project contribute to social development in South Africa?	Amatikulu CPA’s construction and establishment will create a number of jobs, both temporary and permanent, and promote local enterprise development, for which the local community will be a privileged beneficiary. Moreover by contributing to renewable energy generation in South Africa, this CPA will serve the improvement of quality of life of the South African people currently confronted with a national shortfall.
Economic	Does the project contribute to national economic development?	Amatikulu CPA development will help creating an additional revenue stream within the national sugar industry. Besides, the CPA will enable technology transfer to South Africa by involving world-class power-and-heat equipments and skills to be durably set up locally and replicable throughout the programmatic approach.
Environmental	Does the project conform to the National Environmental Management Act principles of sustainable development?	Amatikulu CPA will aid in addressing the current electricity supply constraints in South Africa. This type of electricity generation facility is more environmentally friendly than the coal-derived power currently serving much of the regional electrical distribution grid. Coal-derived power plants tend to emit more harmful gasses, such as sulphur dioxide and nitrogen oxides, and are more carbon-intensive, as well as being unsustainable in the long-term. Besides, the CPA will promote the recovery and utilization of biomass residues currently abandoned or incompletely tapped, as well as “green harvesting” amongst certain sugar cane growers/suppliers, therefore decreasing the burning of sugar cane and associated environmental impacts.
General acceptability	Is the distribution of benefits reasonable and fair?	As demonstrated above, Tongaat Hulett initiative will consequently increase profitability across the whole value chain of the sugar industry, thus widely sharing the benefits from the small local growers (whose earnings will rise) to the surrounding communities and country-wide electricity consumers.

A.4. Entity/individual responsible for CPA

Tongaat Hulett Ltd (hereafter referred as “Tongaat Hulett” or “the Project proponent”) is an agricultural and agri-processing business which includes integrated components of land management and property development. Through its sugar and starch operations, Tongaat Hulett produces a range of refined carbohydrate products from sugar cane and maize.

The Amatikulu Sugar Mill is one of four sugar mills which are owned and operated by Tongaat Hulett in South Africa. All of these mills are situated on the northern coast of KwaZulu-Natal, an area well-known for sugar production, with an estimated output of 10 million tons of cane in an average season.

Tongaat Hulett has more than 42,000 employees working in about 25 locations in 6 countries, South Africa, Botswana, Namibia, Swaziland, Mozambique and Zimbabwe, and conducts its business operations in a manner that seeks to create value for all stakeholders, in a sustainable manner that contributes meaningfully to the social and physical environment in which it operates.

The company’s participation in various sustainability reporting initiatives, including the Carbon Disclosure Project (CDP), the CDP Water Disclosure Project and its listing on the JSE’s Social

Responsibility Investment index for the seventh consecutive year are testimony to Tongaat Hulett's approach to sustainable development.

A.5. Technical description of the CPA

a) Scenario existing prior to the start of the implementation of the project activity

The Amatikulu Sugar Mill comprises sugar cane handling facilities, a sucrose extraction and recovery plant, and the power plant – that is related to the project activity at stake. It operates for approximately 36 weeks of the year, between the months of April and December, and has a milling capacity of 385 tons per hour; this process creating a large amount of by-product (bagasse, tops and leaves). All the sugar cane delivered to Amatikulu sugar mill is supplied by private growers; 98% of it is burnt at the fields to facilitate its harvesting and to minimise the transport costs.

The sugar mill is capable of crushing about 2 million tons of cane per annum. The sugar cane supply dwindled over the years for a variety of reasons, ranging from recent droughts to low world sugar price dynamics. More recently, interventions have been underway to increase the sugar cane supply as evidenced by last year's progress. The sugar cane supply is expected to further improve over the next three years to a point where the spare milling capacity is eliminated. The extent to which the sugar mill has been running below capacity is shown below.

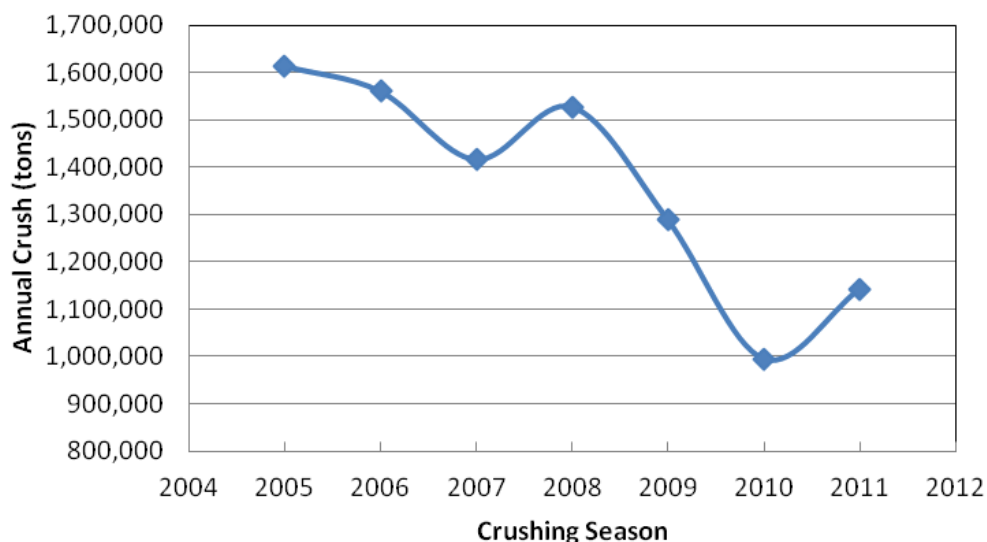

Figure 1: Amatikulu crushing history

In the existing situation prior to the start of the implementation of the project activity, Amatikulu sugar mill currently utilises bagasse as a primary fuel source (historical combustion average of 50 tons of dry bagasse per hour) in low efficiency steam cycles to supply all its steam and power requirements (occasionally completed with 5-10% of coal in case of bagasse supply interruption and maintenance).

The boiler station is composed of four Babcock & Wilcox dual-fuel boilers of 37.5 tph each and one John Thompson biomass-only boiler of 85 tph, for a total available steam capacity of 253 tph¹ and an historical average efficiency of 74%. All existing boilers feature a steam pressure of 32 bar and a steam temperature of 370 °C. The power house comprises three back-pressure turbo-generators of 4 MW each, operating at an efficiency of 0.039 MWh/GJ.

¹ Although the 4 B&W boilers original design was for 37.5 t/h of steam each, small modifications over time have improved their capacity to an upgraded throughput of 42 t/h which was reliably and durably achieved in the recent years.

The age of Amatikulu power plant is 47 years. Besides the routine annual maintenance, specialised maintenance is conducted every 10 years on each boiler in the form of partial tube replacement, which is staggered over 10 years for the five boilers. Furthermore, each turbo-alternator is overhauled every 5 years, again staggered over 5 years for the three turbo-alternators. Given the routine maintenance and periodic overhauls, the remaining life of the boilers and turbo-alternators is demonstrably in excess of 25 years².

b) *Baseline scenario*

In the baseline scenario, the bagasse would still be combusted in a low efficiency cogeneration unit to ensure the sugar factory's heat and power needs (i.e. with 370°C/32 bar boilers and 12 MW of backpressure turbine capacity), occasionally complemented with 5-10% of coal in case of bagasse supply interruption and maintenance. The sugar cane leaves would still be burnt at the fields.

Assuming that the quality of the sugar cane remains similar to the period from 2005 to 2009, the sugar mill design capacity would increase from 385 to 433 tons cane per hour from 2018 onwards, thanks to the debottlenecking of the Amatikulu sugar mill, justified by both upstream increasing sugar cane supply³ and downstream long-term prospects for increased sugar demand in Southern Africa⁴. The average crop duration would remain expected at 36 weeks i.e. 252 days, while the steady-state operational time of the sugar factory would average 87.5 % thus 5,292 hours per annum.

As an economical and straightforward expansion, an extra 32 bar boiler similar to the 37.5 tph existing ones would be implemented to match the process steam demand. The baseline steam demand is partly driven by existing prime movers that are particularly inefficient power rotating equipment (equivalent to 4.5 MW load with a consumption rate of 17.5 t/MWh, compared to the existing back-pressure turbo-alternator consumption of 8.1 t/MWh).

From 2018 onwards, the targeted level of sugar production of Amatikulu mill is 263,118 tons of sugar per annum.

c) *Technical description of the proposed project activity*

The proposed renewable electricity generation facility will consist of two new high-pressure boilers at 110 bar and two turbo-alternators for the generation of 91 MW of electricity, along with the associated plant, to be commissioned in 2018. The boilers will be fed from a supply of sugar cane fibre (bagasse), supplemented by cane leaves (10% of cane-based heat) and wood chips (5% of total heat). The sugar cane leaves would come from the cane fields surrounding Amatikulu and be transported to the sugar mill together with or separate from the sugar cane by road (< 30 km average round trip), while the wood chips, a by-product of the nearby wood industry currently burnt for destruction, will be sourced from saw mills within a distance by road (< 200 km average round trip).

The steam is raised by combusting sugar cane fibre, leaves and wood chips within the 2 x 200 tph high-efficiency boilers (94%). In this regard, the project incorporates significant technological enhancements compared to prevalent practice in that the boiler pressure chosen for the project activity is 110 bar, a first-of-its kind compared to the national average of 32 bar for sugar factories. The steam generation process also requires that the water used to raise the steam be treated in order to minimize potential corrosion and

² Independent Report on remaining lifetime of Amatikulu boilers and turbo-alternators provided to the DOE

³ Among which crop improvements measures and substantial cane root planting following last year's drought (from Tongaat Hulett Interim results 2011)

⁴ Growth expectations above 3% per annum from 2011 (as per Global Agricultural Information network's semi-annual assessments of Sugar Production and Demand in South Africa)



scaling of the boiler tubes. Such water preparation normally includes the clarification, demineralisation and deaeration of the boiler feed water.

The steam generated by the boilers will drive two turbo-alternators of 33.6 MW (back-pressure) and 57.7 MW (condensing), from where the electricity generated will be exported at a voltage of 132kV. The total generation capacity of the renewable energy facility will be 91 MW, equivalent to a season-averaged total generation of 82 MW, out of which 55.1 MW would be available for export into the grid after netting off the sugar mill and power station auxiliary power consumption. This large-scale power export from bagasse cogeneration is also a first-of-its kind in the country, as any electricity that is produced in excess of factory requirements for external use is very limited elsewhere and well below the 15 MW level.

In order to satisfy the operational requirements of the sugar processing, the facility will provide the sugar mill with a supply of low pressure process steam. After condensation in the first effect evaporators, the majority of the condensate generated from the exhaust steam will be returned to the facility for reuse as boiler feed water. Some additional exchange of water / condensate streams between the two entities will be carried out in order to optimise the efficient use of water on the Amatikulu site.

Various measures and modifications will be implemented to improve the sugar mill energy efficiency and optimise the steam available for power generation to the grid, reducing the process steam consumption from 66.56% high pressure steam on cane to 39.55% high pressure steam on cane:

- All prime mover turbines will be replaced with electric motors,
- Many process heating loads will be moved onto lower-grade (lower temperature) sources of vapour obtained by vapour bleeding from the multiple effect evaporator station,
- Additional heat transfer equipment will be installed to facilitate this use of lower-temperature vapours,
- The condensate handling system will be modified to allow for stage-wise flashing of the condensate streams to progressively lower pressures, to recover flash vapour for process heating,
- The evaporator station will be changed from quintuple effect to sextuple effect to improve energy efficiency,
- Three batch pans (evaporative crystallisers) will be replaced with continuous pans in order to allow for the use of lower-temperature vapour to drive the evaporation,
- Clarified cane juice will replace the use of hot water in several applications in the plant, so as to minimise the addition of water,
- Many electric motors driving rotating equipment will be replaced with higher-efficiency units; and variable frequency drives will replace many control valves.

As a result of the mills electrification, the electrical power consumption of the factory will be expected to increase by 4.5 MW (or 26,244 MWh/y), while the more efficient use of electricity within the sugar factory (efficient motors, variable frequency drives, etc.) is expected to save 6,854 MWh/y.

Installation and operation of the high efficiency cogeneration plant do not pose any environmental hazards. The technology of generating electricity through biomass residues combustion is environmentally safe and sound, as confirmed by the EIA process (see Section B – Environmental Analysis).

The flue gas generated in the boilers will be scrubbed for particulate matter using dry scrubbing technology, thus ensuring that the air emissions generated as a result of this facility fall within the conditions and stipulations of the National Environmental Management: Air Quality Act. The ash and unburnt combustibles resulting from the boilers operations will be disposed of over the existing cane fields in order to condition the soil for cane growing and return nutrients essential for plant growth. Further to this a by-product of the water demineralisation process is a dilute liquid stream (effluent), which will be disposed of by a reputable effluent disposal company.

The project activity has an expected lifetime of above 25 years, as advocated by the default values for technical lifetime of boilers and turbines of the *Tool to determine the remaining lifetime of equipment* Version 01 EB 50.

Table 1: Comparative summary of baseline and project activity scenarios technical characteristics

<i>Type and level of services provided</i>		Baseline scenario		Project activity	
		sugar : 263,118 tons/y		sugar : 263,118 tons/y	
Biomass fuels					
Wet quantity of cane crushed		2,290,378 tons/y		2,290,378 tons/y	
<i>Moisture content of cane</i>		68.9 %		68.9 %	
Dry quantity of bagasse fired		372,674 tons/y		372,674 tons/y	
<i>NCV of bagasse (dry basis)</i>		14.5 GJ/ton		14.5 GJ/ton	
Dry quantity of leaves fired		-		32,627 tons/y	
<i>NCV of leaves (dry basis)</i>		-		18.4 GJ/ton	
Dry quantity of woodchips fired		-		19,931 tons/y	
<i>NCV of woodchips (dry basis)</i>		-		15.9 GJ/ton	
Equipments specifications					
Boilers	Boiler(s) capacity	4*42 + 85 + 37.5 tph		2 x 200 tph	
	Average boiler(s) load	268 tons of steam/h		302 tons of steam/h	
	Annual steam production	1,619,674 tons/y		2,052,313 tons/y	
	Temperature & pressure	370°C @ 32 bar a		540°C @ 110 bar a	
	Efficiency	81.8%		94%	
Turbines	Turbine(s) type	Backpressure	Direct drive (mills)	Backpressure	Condensing Extraction
	Alternator rated capacity	12 MW	4.5 MW	33.6 MW	57.7 MW
	Steam spec. consumption	8.1 kg/kWh	17.5 kg/kWh	4.61 kg/kWh	3.58 kg/kWh
Power					
Annual gross power generation		63,504 MWh		435,522 MWh	
Annual on-site power consumption		65,957 MWh		143,830 MWh ⁵	
Annual power export/(import)		8,078/(10,531) MWh		302,223/(10,531) MWh	

The use of coal, although occasionally co-fired at 5-10% in baseline in case of bagasse supply interruption and maintenance, is not intended anymore in the Project thanks to alternative biomass residues sources, and will be strictly limited to operational emergencies not exceeding 48 hours at a time.

A.6. Party(ies)

Name of Party involved (host) indicates a host Party	Private and/or public entity(ies) CPA implementer(s) (as applicable)	Indicate if the Party involved wishes to be considered as CPA implementer (Yes/No)
Republic of South Africa (host)	Tongaat Hulett Ltd	No

A.7. Geographic reference or other means of identification

⁵ The increase of on-site power consumption between the baseline and the project activity is mainly due to (i) mills prime movers electrification and (ii) new power house auxiliary consumption.

The facility is to be established within the property of the Amatikulu Sugar Mill, which borders the Matigulu River, along the R66 Road, Amatikulu, KwaZulu-Natal (KZN), at co-ordinates 29° 02' 44.69" S and 31° 31' 35.65" E.



Figure 2: Location of the CPA in South Africa (source: United Nations Cartographic Section)

The sugar mill site is precisely located on Subdivision 1 of the Farm Lot 55 Amatikulu, Number 13917, within the Umlalazi Municipality of KwaZulu-Natal.

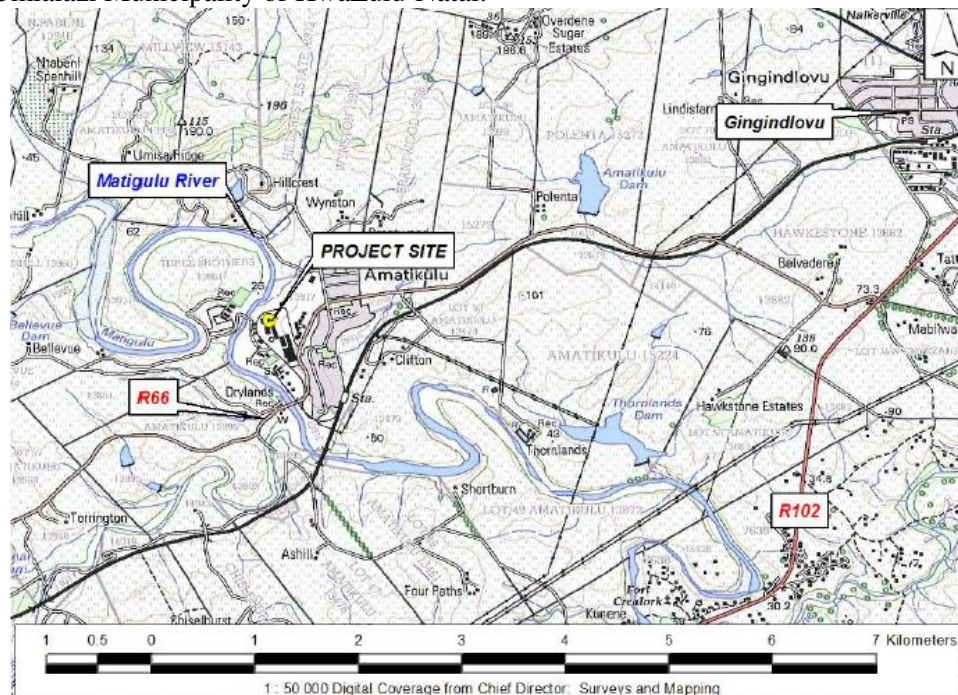

Figure 3: CPA locality plan (source: Final Scoping Report)

A.8. Duration of the CPA

A.8.1. Start date of the CPA

Start date of Amatikulu CPA is 01/12/2013: expected submission date of Tongaat Hulett final bid to the renewable biomass energy Independent Power Producer procurement program's Request for Proposal by the Department of Energy (Medium Term Risk Mitigation), including a non-refundable financial deposit.

A.8.2. Expected operational lifetime of the CPA

The expected lifetime of Amatikulu CPA is greater than 25 years. This is largely greater than the chosen crediting period length, and compatible with the PoA lifetime of 28 years.

A.9. Choice of the crediting period and related information

The crediting period will be fixed.

A.9.1. Start date of the crediting period

The crediting period will start on 01/01/2018 (expected date of commissioning of Amatikulu CPA) or on the date of inclusion of Amatikulu CPA under the PoA, whichever is later.

A.9.2. Length of the crediting period

The crediting period will be fixed and last for ten years. Therefore the crediting period shall end on 31/12/2025 or at the tenth anniversary of the inclusion date, whichever is later. Since the inclusion date and the registration date of the PoA are the same, the duration of the crediting period will not exceed the PoA validity period.

A.10. Estimated amount of GHG emission reductions

Emission reductions during the crediting period	
Years	Annual GHG emission reductions (in tonnes of CO₂e) for each year
2018	269,952
2019	269,952
2020	269,952
2021	269,952
2022	269,952
2023	269,952
2024	269,952
2025	269,952
2026	269,952
2027	269,952
Total number of crediting years	10
Annual average GHG emission reductions over the crediting period	269,952
Total estimated reductions (tonnes of CO₂e)	2,699,520



A.11. Public funding of the CPA

The Project does not involve any public funding.

A.12. Confirmation for CPA

The CPA is neither registered as an individual CDM project activity nor is a part of another registered PoA.

SECTION B. Environmental analysis

B.1. Analysis of the environmental impacts

The establishment of the proposed renewable electricity generation facility with a capacity of 91 MW is subject to a submission of a Full Scoping and Environmental Impact Assessment (EIA) Report to the national Department of Environmental Affairs (DEA), under the terms of Activity 1 of Listing Notice 2 of the EIA regulations published in GNR 545 of 2010, read in conjunction with Section 44 of the National Environmental Management Act. (Act 107 of 1998), i.e.;

“The construction of facilities for the generation of electricity where the electricity output is 20 megawatts or more.”

Further to this, the proposed development will also trigger the following activities, falling under Listing Notice 1 of the EIA Regulations published in GNR 544 of 2010, read in conjunction with Section 44 of the National Environmental Management Act. (Act 107 of 1998), i.e.;

Activity 2;

“The construction of facilities for the storage of ore or coal that requires an Atmospheric Emissions License in terms of the National Environmental Management: Air Quality Act (Act No.39 of 2004)”.

Activity 10 (i);

“The construction of facilities or infrastructure for the transmission and distribution of electricity outside of urban areas with a capacity of more than 33 but less than 275 kilovolts.”

Activity 12;

“The construction of facilities or infrastructure for the off-stream storage of water, including dams and reservoirs, with a combined capacity of 50000 cubic metres or more, unless such storage falls within the ambit of Activity 19 of Notice 545 of 2010.”

Activity 9 (i);

“The construction of facilities or infrastructure exceeding 1000 metres’ in length for the bulk transportation of water, sewage or stormwater, with an internal diameter of 0.36 metres or more.”

And Activity 28;

“The expansion of existing facilities for any process or activity where such expansion will result in the need for a new, or amendment of, an existing permit or license in terms of the national or provincial legislation governing the release of emissions or pollution, excluding where the facility, process or activity is included in the list of waste management activities published in terms of Section 19 of the National Environmental Management: Waste Act, 2008 (Act No. 59 of 2008) in which case that Act will apply.”

In addition to the EIA Regulations, the proposed development will require licensing through other environmental management legislation. The emissions generated by the boilers will trigger the requirements for an Air Emissions License under Section 21 of the National Environmental Management:

Air Quality Act (Act No. 34 of 2004), listed in GNR 248, Category 1, Subcategory 3. i.e.; “*Solid Biomass Combustion Installations.*”

The proposed disposal of the ash generated by the boilers and the unburnt combustibles onto the existing sugar cane fields will require an application for a waste license under the National Environmental Management: Waste Act (Act No. 59 of 2008), Section 20(b), Category B(10) i.e.; “*The disposal of general waste to land covering an area in excess of 200m².*”

The construction of the reservoir will require an application for water use authorization under Section the 21 (b) of the National Water Act (Act No. 36 of 1998). This has been undertaken by the Project Applicant.

The abstraction of water from the Matigulu River will not require any permits from the Department of Water Affairs, as it will operate within the conditions and stipulation of the existing water use permit for the Amatikulu Sugar Mill.

The application for a Waste License and an Air Emission License will be undertaken as part of the EIA phase for this development.

Besides, a recently released National Climate Change Response White Paper (2011) aims at to facilitate management of future climate impacts, as well as to promote, and contribute to, the stabilization of the greenhouse gasses (GHG) present in the atmosphere. This white paper is especially relevant to this development, as the facility would aid the sustainable development of the local sugar industry and displace some of the coal-derived power which services much of South Africa.

In cognizance of the above requirements, Dr. A.B. Hlatshwayo of Tongaat Hulett has requested that Mr. J. Thompson of Geomeasure Group undertake the EIA process for the proposed project.

B.2. Environmental impact assessment

The following table comprises a summary of the implications and mitigation of each environmental aspect. The methodology used to rate the environmental impacts was qualitative. Each category was divided into a number of different levels. These levels were then assigned various criteria.

Table 2: *Environmental Impacts assessment and mitigation*

Impact	Extent	Duration	Probability	Significance Without Mitigation	Significance With Mitigation	Mitigation Measures
Biophysical Environment						
<i>Climate</i>						
Wind speeds and direction may aid in the dispersal of emissions emanating from the boiler stacks. Please see ‘Air Quality’.	Local	Long Term	Definite	Medium (+)	N/A	Emissions are likely to be dispersed to surrounding areas, however air quality measures such as the electrostatic precipitator will ensure the emissions meet with the air emission standards as per the National Environmental Management: Air Quality Act (Act No.34 of 2004).
Rainfall may have a number of	Local	Long Term	Definite	Medium (+)	N/A	Mitigation measures are contained under ‘Stormwater’.



detrimental environmental impacts. Please see 'Stormwater'.						
<i>Topography/ Visuals</i>						
The renewable electricity generation facility is not anticipated to have a visual impact, due to the surrounding industrial infrastructure.	-	-	-	-	-	No change.
The reservoir has the potential to have a visual impact, depending on design and location.	Site	Long Term	Definite	Medium (-)	Low (-)	The visual impact of the reservoir will be offset by the use of earthen banks, as well as its location on a relatively flat hilltop.
Construction activities may have a negative impact on neighbouring residents, predominantly with regards to the reservoir site.	Site	Short Term	Possible	Low (-)	Low (-)	The construction camp area at the reservoir site should be demarcated with green shade cloth or fenced, so as to reduce visual impact.
<i>Air Quality</i>						
Air emissions from the boiler stacks at the renewable electricity generation facility could impact negatively on the surrounding environment, especially with regards to particulate matter.	Local	Medium Term	Probable	Medium (-)	Low (-)	<p>An electrostatic precipitator will be utilised in the process in order to reduce potential particulate matter emissions. An Air Quality Management Plan will need to be compiled and implemented and must include;</p> <ul style="list-style-type: none"> - Frequent (annual) stack monitoring be undertaken to demonstrate the efficiency of the boiler emission abatement technology used. - Investing in a dust monitoring network to track the spatial extent of the particulate matter being emitted. - Conducting real-time analysis of particulate matter concentrations prevailing at the site. This will serve as background ambient air quality data which can be used for further air pollution modeling. <p>An on-site meteorological</p>



						station should be installed and operated to measure hourly sequential data for the following parameters: wind speed, wind direction, temperature relative humidity, precipitation which can also be used for further air pollution modeling.
Dust may be created during the construction phase of the development, especially during the construction of the reservoir as this will entail large areas of exposed soil.	Local	Short Term	Possible	Medium (-)	Low (-)	During construction periods where dust is or has the potential to be created, dust suppression (such as the watering of exposed areas) will need to be utilised on an as required basis.
Displacement of coal-derived electricity currently making up the majority of the regional power supply.	Local	Medium Term	Possible	Medium (+)	Medium (+)	None required (positive impact).
Decrease of local farmers burning sugar cane crops prior to harvesting (in favour of 'green harvesting') will improve air quality in the immediate area.	Local	Medium Term	Possible	Medium (+)	Medium (+)	None required (positive impact).
<i>Geology & Soils</i>						
Possible settlement and consolidation may occur as a result of the renewable electricity generation facility.	Site	Medium Term	Unlikely	Medium (-)	Low (-)	Due care must be exercised. Further geotechnical investigation will be required in order to determine if piling will be necessary.
Similar geotechnical impacts could occur at the reservoir site, should due care not be exercised.	Site	Medium Term	Unlikely	Medium (-)	Low (-)	
Disposal of boiler ash on cane fields which has been generated during emergency situations (i.e. with the use of coal) may lead to elevated constituents in the soils such as	Site	MediumTerm	Possible	Low (-)	Low (-)	



Arsenic.						
Disposal of boiler ash on cane fields will provide a number of nutrients and aid in moisture retention. It is also beneficial as an organic amendment to suppress fungal and nematode pathogens	Site	Medium Term	Likely	Medium (+)	Medium (+)	
Construction activities (such as spills and the exposing of soil) may impact negatively on soil quality and cause erosion, which in turn may have a number of negative cumulative impacts.	Local	Short Term	Possible	Medium (-)	Low (-)	
<i>Health</i>						
The operation of the renewable electricity generation facility poses a number of potential health and safety risks.	Site	Long Term	Possible	Medium (-)	Low (-)	The proposed facility will need to comply with Tongaat Hulett's existing health and safety policies (see Appendix Q). A Safety Officer will be assigned for the site. The health and safety policy includes the type of PPE required to be worn by people accessing and operating the site. All employees involved in the operation of the site must be suitably trained, including how to deal with emergency situation. In addition staff must also be trained in the handling of the hazardous chemicals to be stored on site, the MSDS for which are included in Appendix S. Finally the storage of these chemicals will be subject to a risk assessment, as per the Occupational Health and Safety Act.
The construction of both the renewable electricity facility and the reservoir could pose risks to the health and safety of contractors, and potentially to passers-by as well.	Local	Medium Term	Possible	Low (-)	Low (-)	Site access to both construction sites will need to be controlled at all times. Security will need to be provided at the reservoir site. Further conditions and stipulations pertaining to health and safety measures during construction have been contained in the draft EMP.



<i>Surface Water</i>						
Impact of water abstraction on the Matigulu River, particularly during times of stress.	Local	Medium Term	Possible	Medium (-)	Low (-)	The abstraction of water from the Matigulu River will need to fall within the existing Tongaat Hulett's permissible raw water allocation from the Matigulu River. In addition the rate of abstraction from the Matigulu River must be governed by the existing Water Court Order for Tongaat Hulett.
Construction activities have the potential to pollute the Matigulu River.	Local	Short Term	Possible	Medium (+)	Low (+)	No construction activities will be permitted within 32 m of the Matigulu River, as per the layout plan contained in the wetland delineation (see Appendix O). Portable toilets should also be included in this buffer, and should be placed as far away from the water course as possible.
<i>Groundwater</i>						
Potential migration of determinants, resulting from the disposal of ash, into the shallow groundwater underlying the site (only during emergency situations where coal is utilized).	Local	Medium Term	Possible	Low (-)	Low (-)	During emergency situation when coal is used the boiler ash will be collected and disposed of at a registered hazardous landfill site and not the surrounding sugar cane fields, therefore the elevated determinants of concern should not be present in the soil.
Leaking anaerobic pond and sewerage treatment works.	Local	Short to Medium Term	Probable	Medium (-)	Low (-)	The anaerobic pond should be lined. The anaerobic pond must be refurbished as part of the project development. The existing volume of the anaerobic pond will remain unchanged. The existing anaerobic pond will be re-designed to comply with the guidelines detailed in Section 7.7.
Impact from historical ash spread on shallow subsoil underlying the sugar cane fields.	Local	Short to Medium Term	Probable	Low (-)	Low (-)	Ongoing surface water and soil quality monitoring is recommended at the farms involved in the additional investigation. The collected samples will need to be analysed for arsenic, cadmium, cobalt, copper, total chromium, hexavalent chromium, electrical conductivity, fluoride, mercury, chloride, sulphate, nickel, nitrite, nitrate, lead, pH, total cyanide, vanadium, zinc and manganese. Children and public should be



						kept off of the farm sites where possible. In addition, on-site workers should be encouraged to minimise inhalation of dust from the areas historically subjected to ash disposal practices (smutting) A toxicological investigation of the soils impacted by the ongoing ash disposal practices (smutting) should be conducted by a qualified toxicologist, so as to determine whether in fact a risk to human receptors as well as the receiving environment as whole exists as a result of this practice
Flora and Fauna						
'Green harvesting' of sugar cane will decrease the number of local farmers burning crops prior to harvesting.	Local	Medium Term	Probable	Medium (+)	Medium (+)	'Green harvesting' of sugar cane crops will reduce the number of fauna killed/displaced by the more traditional burning of crops.
Traffic						
No impact	-	-	-	-	-	-
Noise						
Noise generated by turbo-alternators impacting on areas immediately surrounding Amatikulu Sugar Mill.	Local	Medium	Unlikely	Low (-)	Low (-)	Turbo alternators to be enclosed so as to prevent noise. Noise impact will not be noticeable due to high ambient noise level currently at the mill.
Noise generated by facility impacting on hearing of employees involved in operation of facility.	Site	Medium	Possible	Medium (-)	Low (-)	All employees operating and within close proximity to the facility to wear hearing protection at all times.
Heritage						
The reservoir area may have cultural resources.	Site	Short term	Unlikely	Low (-)	Low (-)	An application for a desktop study has been made to Amafa, for which we are currently awaiting the results.
Social Environment						
Economic						
The proposed development will help create an additional revenue stream within the local sugar industry.	Local	Medium Term	Definite	Medium (+)	Medium (+)	None required (positive impact).
The proposed development may be positively impacted by a future government	Region	Medium Term	Probable	Medium (+)	Medium (+)	None required (positive impact).

procurement programme.						
<i>Social</i>						
A number of jobs will be created during the construction and operational phase of the development.	Local	Medium Term	Definite	Medium (+)	Medium (+)	Local people should be given preference for jobs created during the construction phase of the development.
Additional electricity supply (89 MW) added to the local power grid.	Region	Medium Term	Probable	Medium (+)	Medium (+)	None required (positive impact).

Summary of Environmental Impacts and Issues scoping

Potential project impacts have been identified in Table 2 above. The key issues are summarized as follows:

Potential positive impacts

- Creation of an additional revenue stream for the local sugar cane industry.
- Promotion of ‘green harvesting’ amongst certain sugar cane growers/suppliers, therefore decreasing the burning of sugar cane and associated environmental impacts.
- Job creation during the construction and operational phases of the development, with focus on the local community.
- Displacement of coal-derived electricity with a ‘greener’ type of electricity (i.e., less harmful emissions).
- Supply of 89 MW of electricity during a period when there is currently a national shortfall.

Potential negative impacts

- The combustion process will generate emissions, however, the installation will be subject to an Air Emissions License under the National Environmental Management: Air Quality Act (Act No. 34 of 2004), and, should it be made to comply with the conditions and stipulations of this Act, the potential environmental impact should be mitigated.
- The disposal of the ash and unburnt combustibles may impact the soil quality and groundwater underlying the sugar cane fields. However the replacement as coal as a supplementary fuel (with untreated wood chips) should negate this issue.
- The abstraction of water may negatively impact the Matigulu River during times of stress. It is very important that the abstraction of water from this source is done in accordance with the existing Water Court Order for Tongaat Hulett. In addition, the abstraction of water from this source may not exceed Tongaat Hulett’s permissible raw water allocation from the Matigulu River.

Conclusion and Recommendations

The proposed development should have a number of positive impacts, including;

- eliminating the burning of coal as a supplementary fuel, with a positive impact on both emissions and solids disposal;
- improving the particulate emissions technology to ensure that the boilers meet the new regulations of 50 mg/Nm³;
- improving liquid effluent treatment and lining the anaerobic pond;
- a number of benefits to the local sugar industry.



It is concluded that, based on all available information, the proposed Amatikulu Renewable Electricity Generation Facility should have a number of positive financial, social and environmental impacts, especially for the local sugar industry. There are a number of potential negative impacts, however these can be mitigated to a large extent, provided that the conditions and stipulation arising from the EIA report are followed, and should not prevent the development from going ahead.

Chronology of the EIA process

The application form required in terms of 2010 EIA Regulations was completed and submitted to the DEA on the 5 July 2011. As the project involves the generation of electricity, it was required that the application be submitted to the DEA instead of the KwaZulu-Natal Department of Agriculture, Environmental Affairs and Rural Development (DAEARD). Receipt was acknowledged by the DEA on the 24 August 2011 and the following reference numbers were assigned;

National Environmental Authorisation System (NEAS) Reference: DEA/EIA/0000415/2011 DEA Reference: 12/12/20/2356

After the submission of the original application, the Department of Environmental Affairs requested that an integrated application form, combining the applications for Environmental Authorisation and a Waste License, be submitted to them, whilst retaining the assigned reference numbers. The amended application form was submitted in early December 2011.

The final Scoping Report was submitted to DEA on 16 March 2012. The letter of acceptance of the Scoping Report was received on 2 May 2012. The draft EIA report was sent out to all of the listed authorities and stakeholders on 25th July 2012. A number of the authorities and stakeholders provided comment on the draft EIA Report. Upon resolution of the arising issues and integration of the comments and responses, the final EIA report was received by the Department of Environmental Affairs on 12 September 2012. The environmental authorization has been granted in December 2012⁶.

SECTION C. Local stakeholder comments

C.1. Solicitation of comments from local stakeholders

Procedure followed to invite stakeholder comments

Site notices were placed around site and advertisements were placed in appropriate newspapers⁷, giving rise to a list of Interested and Affected Parties (I&APs). Background Information Documents were distributed to all neighbouring businesses/landowners. In addition the Zululand Planters Association, Ward Committee and Proportional Representation (PR) Committee for Amatikulu were contacted and provided with project information. A complete list of all of the I&APs, including DWA, the Department of Health, Umlalazi Municipality, KZN Wildlife, WESSA and the relevant Ward Councilor, as well as the related contact details, is contained in the Final Scoping Report Appendix C.

Program of the public meeting

Date: 14/11/2011

Place: Amatikulu Sugar Mill Boardroom

Language: English

Time: 4.00 pm

⁶ Environmental Authorisation (EA) from the Environmental Affairs Department was provided to the DOE.

⁷ Site notices were placed at the Amatikulu Sugar Mill entrance on the 23 September 2011. Advertisements were placed in the Natal Mercury on the 2 September 2011 and the Isolezwe on the 2 September 2011.

**Meeting procedure:**

- Introduction
- Objectives of public consultation
- Project description
- Environmental/CDM and socio-economic impacts
- Questions and answers from participants
- Conclusion
- *Refreshment*

The attendance register and minutes of the public meeting are presented in the Final Scoping Report Appendix C.

C.2. Summary of comments received

The proposed development was presented to the I&APs and a number of queries and comments were raised as reported below.

Participant's questions/concerns	Project proponent's answers
Was the cane residue the only alternative source of fuel that was investigated for this development?	Yes, this development has been limited, at this stage, to sugar cane tops and trash and fibre in an attempt to make the sugar process more sustainable. However alternative sources of fuel for the boilers, for example wood chips, may be investigated in the future once the development has been established.
What is the situation with regards to the proposed development and the government tariffs associated with electricity generation?	There are currently no tariffs in place for electricity generated from sugar cane fibre, however it is anticipated that this type of electricity will be accommodated in future government electricity procurement programmes.
How will the sugar cane tops and trash be collected / introduced into the process?	The large majority of the fuel used in the facility will consist of bagasse, which is a co-product of the sugar process and already available at the Amatikulu Sugar Mill. Sugar tops and trash are expected to be brought in by the growers/ suppliers.
It was mentioned that tops and trash can be corrosive within the process, how is this so?	Large amounts of tops and trash may cause a buildup of alkali metals, which would have an adverse effect on the life on the boilers. It is for this reason that the majority of the boiler fuel will be limited to bagasse, with a smaller percentage being made up of the sugar cane tops and trash.
Has the whole stalk and tops been considered as a fuel source?	It has been considered and a fair amount of such cane is currently being processed by the sugar mill. The extent of processing such material is limited by the capability of the sugar mill to handle such cane.
Will the Matigulu River be able to supply the project during dry periods with the increased upstream usage?	The reservoir proposed for the development will fall under the existing water use license for the Amatikulu Sugar Mill and will not exceed the stipulations/limitations of this license. The intention of the reservoir is not to increase the extraction of the water from the Matigulu River, but rather to ensure that there is a constant water supply at all times that the facility is operational.
Is this process more 'green' than coal power?	Definitely. The coal-derived electricity process is the source of a number of emissions in large quantities, including sulphur dioxide and nitrogen oxides and is more carbon-intensive. This process is also not sustainable in the long term.
What are the characteristics of the ash that is to be deposited on the	Sugar cane ash has historically been used as a fertilizer on the canefields, however it is considered to be a waste product by the



canefields?	Department of Environmental Affairs and therefore requires a waste license to be disposed on these fields. Therefore the characteristics of the ash will be investigated and determined as part of the EIA Report.
Will the development create more jobs?	Yes, there will be a number of jobs created by the development, both temporary and permanent. Some of the jobs created will be as a direct result of the establishment and operation of the proposed development, while it is also anticipated that a number of jobs will be created indirectly. Members of the local community will also be favoured for a number of the jobs created.
What is the financial investment, per each of the KZN sugar mills, for these developments, from Tongaat Hulett?	This issue has not yet been resolved, however the project capital cost will be in excess of R2 billion.
How dependant is the local community on the sugar mill?	The local community is very dependent on the sugar mill, and the large majority of the local residents are employed by the mill in some capacity.
The mayor or municipal manager should be engaged to help promote the development.	Noted, this will be undertaken during the Scoping and EIA process going forward.
What is the view with regards to the roll-out of the four renewable electricity generation projects, i.e. Amatikulu, Darnall, Felixton and Maidstone?	At this present point in time the EIA processes for all four of the renewable electricity generation facilities are being conducted concurrently.
Once the EIA is complete how long will it take to construct the facility?	Once the EIA is complete there are still a number of issues to be resolved. Once everything has been resolved, it is anticipated that it will take approximately two years to construct the facility.

Subsequent comments were also received following the draft Scoping report release to all of the registered I&APs, stakeholders and relevant authorities, as summarized below.

Stakeholder's remarks/concerns	Project proponent's answers
Management of solid waste generated during the construction phase and post construction phase of the renewable electricity generation project must be addressed	This issue will be addressed in the EMP.
Management of any hazardous waste material generated pre- and post construction must be addressed.	This issue will be addressed in the EMP.
Identification of any environmentally sensitive areas and water resources such as wetlands, rivers, groundwater, etc. as well as possible pollution impacts and mitigation measures of such water resources must be undertaken.	A wetland delineation will be undertaken during the EIA phase off the development. In addition these areas will be identified as a continuation of the impact assessment process.
Stormwater management plan/system including the prevention of erosion and sedimentation.	Stormwater management and erosion control measures will be addressed in the EIA Report and will also form part of the EMP.
Sewage treatment and disposal (i.e. waste management) must be addressed. This should include the type of toilet facilities provided for construction workers. It is assumed that the sewage/effluent will be discharged to a wastewater treatment works. DWA must be notified if an existing sewage works will	During the construction of the renewable electricity generation facility and the reservoir portable toilets will be utilised. The management of these toilets will be addressed in the EMP.



be able to accommodate the sewage effluent or a new waste water treatment works will be erected for the new development and the capacity of the sewage works to handle both the volume and load of the effluent must be mentioned.	
Information regarding the 1:50 and 1:100 year floodlines must be included on the map.	This information will be included on a map which will form part of the EIA Report.
Spill Contingency Plans.	This issue will be addressed in the EMP.
Geotechnical and geohydrological investigation.	A geotechnical investigation will be undertaken as part of the EIA phase. The need for a geohydrological study will be further discussed with DWA during the EIA phase.
Environmental Management Plan.	A draft EMP will be submitted to DEA with the EIA Report.
According to the National Water Act (Act No. 36 of 1998), the applicant must apply for a Section 21 (b) Water Use Authorisation for the storage of water in a reservoir with a capacity of 700,000 m ³ . Mr. Norman Ward from the Water Resources Management Section of this Department must be contacted on 031 336 2700 should there be any alteration to the beds, banks, course or characteristics of a water course, or any impedance or diversion of flow of a water course as well as any abstraction and/or storage of water.	Noted. An application for a water use license will be undertaken by the Project Applicant
Mr. Ivor Hoareau from this DWA's Dam Safety Office must be contacted for the reservoir/dam on 031 336 2700. The applicant's attention must be drawn towards the following section in the National Water Act (Act No. 36 of 1998): Sections 117, 118, 119, 120 and 121 regarding dam safety.	Noted.
The removal of any indigenous trees may need to be authorized by the DWA's Forestry section. Please contact Joyce Nelushi on 033 342 8101.	This issue will be addressed in the EMP.
Please note that all wetlands on site must be delineated according to DWA's guideline entitled ' <i>A practical field procedure for identification and delineation of wetlands and riparian areas.</i> ' (DWAF, 2005).	Noted.
There must be a 20m buffer from the edge of any temporary wet zone of the wetland to the edge of edge of any structural development. Visible markings showing/demarcating the 20m buffer must be provided on site during the construction phase.	This issue will be addressed in the EMP.
If the applicant wishes to develop (structures, roads and other infrastructure) on the wetland/riparian zone or within the prescribed buffer as well as to rehabilitate any wetlands/riparian zone on the said property, an authorisation in terms of Section 21 of the National Water Act may be required. Please contact Mr. Norman Ward from the Water Resources Management Section of the Durban Office on 031 336 2700 as well as Ms. Barbara Weston from the DWA Pretoria Office on 012 336 8221 for further enquiries in this regard.	Noted.
The generation of electricity from a renewable resource, particularly a 'waste product' such as sugar cane fibre, is positive and should it achieve the benefits of employment creation and growth and provide additional revenue for the	Noted.



local enterprise development, as well as contribute towards making the sugar industry more sustainable it is supported.	
A factor of concern is the need for a consistent supply of water and although the water requirements are said to be within the current license conditions we trust that ongoing review of process technology will ensure that water use is minimized, and re-used where possible.	Noted for inclusion in the EIA Report.
It is accepted that this option is the most environmentally appropriate however it would need to be assured that abstraction rates will accommodate the ecological requirements of the Matigulu River system during periods of low river flow.	Measures controlling the abstraction of water will be investigated in the EIA and will also be included in the operational phase of the EMP.
How will the generation of electricity, and so the economic viability of the project, be affected should water become unavailable such as during protracted periods of drought?	It will affect the viability of the project and it will necessitate the shutdown of the plant.
Reservoir filling. It is noted that the intention is to reduce stress on the Matigulu River by filling the reservoir over a period of time and this may require discussion with DWA. Details of this aspect should be included in the EIA Report.	As previously mentioned this will be discussed/ investigated in the EIA Report.
Coal may be used as an additional fuel source. Should the use of coal exceed the current use it would need to be factored into the air emission studies. The studies should address all potential scenarios.	This issue will be covered in the appropriate specialist study.
Various methods of pre-processing the bagasse (such as removal of excess moisture) to ensure the efficient burning of the bagasse and the reduction of ash waste must be investigated.	Existing and financially viable technology is only able to dry the bagasse to approximately 50%, as is the current practice at the mill and worldwide. The ash generated in the resultant product is constant.
The potential for reuse of the ash waste in other industrial processes, as an alternative to the disposal of the ash into a landfill site must be investigated.	It is intended that the ash and unburnt combustibles generated by the boilers are to be used as fertilizer on existing crops, as is the existing practice.
Various air filters and scrubbers must be investigated.	Noted. A number of technological alternatives have been investigated.

C.3. Report on consideration of comments received

Neither negative comments nor opposition opinions were received from the consulted public and the direct contributions. Besides, the CPA initiative was widely praised during the questions & answers closing the public consultation, both for its innovative environmental characteristics and for its local employment potential. As guaranteed to all participants, all the relevant issues raised have formed part of the Scoping Report and the minutes of the meeting have been circulated to all registered Interested and Affected Parties.

The entities which provided direct feedback to the Scoping Report (DWA, WESSA and KZN) expressed overall satisfaction and support to the Project activity and their recommendations were duly noted and taken into account in the ongoing Environmental Impact Assessment process.

SECTION D. Eligibility of CPA and estimation of emissions reductions

D.1. Title and reference of the approved baseline and monitoring methodology(ies) selected:

The approved baseline and monitoring methodology selected is: ACM0006 “Consolidated methodology

for electricity and heat generation from biomass” Version 12.1.1 (EB 69).

This methodology also refers to the latest approved versions of the following tools:

- Tool for the demonstration and assessment of additionality (Version 07.0.0, EB70)
- Tool to calculate project or leakage CO₂ emissions from fossil fuel combustion (Version 02, EB41)
- Emissions from solid waste disposal sites (Version 06.0.1, EB66)
- Tool to calculate baseline, project and/or leakage emissions from electricity consumption (Version 01, EB39)
- Tool to calculate the emission factor for an electricity system (Version 04.0, EB75)
- Tool to determine the baseline efficiency of thermal or electricity generation systems (Version 01, EB48)
- Tool to determine the remaining lifetime of equipment (Version 01, EB50).
- Assessment of the validity of the original/current baseline and to update of the baseline at the renewal of the crediting period (Version 03.0.1, EB66)
- Project and leakage emissions from transportation of freight (Version 01.1.0, EB70)
- Guidelines on common practice (Version 02.0, EB69)
- [Tool for the identification of degraded or degrading lands for consideration in implementing CDM A/R project activities is not applicable because there is no A/R component in the project]

D.2. Application of methodology(ies)

The approved consolidated baseline and monitoring methodology ACM0006 is applicable to the proposed CPA, as it involves:

- The installation of new plants at a site where currently power or heat generation occurs. The new plant replaces or is operated next to existing plants (capacity expansion projects).

It further verifies the below application criteria.

Table 3: Applicability of the CPA project activity regarding ACM0006 conditions

Applicability conditions of the methodology	Applicability to Amatikulu CPA	Evidence
(1) No biomass types other than biomass residues and/or biomass from dedicated plantations are used in the project plant;	Amatikulu CPA plant will only use cane bagasse (by-product of sugar production), trash from cane cultivation (leaves) and woodchips from waste, i.e. biomass residues only.	<i>Biomass residues-only projected fuel consumptions; cf. final EIA report's Project activity description.</i>
(2) Fossil fuels may be co-fired in the project plant. However, the amount of fossil fuels co-fired does not exceed 80% of the total fuel fired on an energy basis;	No co-firing of fossil fuels is envisaged in Amatikulu CPA plant, except negligible amounts of coal in case of emergency.	<i>Fossil-free projected fuel consumptions; cf. final EIA report's Project activity description.</i>
(3) For projects that use biomass residues from a production process (e.g. production of sugar or wood panel boards), the implementation of the project does not result in an increase of the processing capacity of raw input (e.g. sugar, rice, logs, etc.) or in other substantial changes (e.g. product change) in this process;	The implementation of Amatikulu CPA does not result in an increase of the processing capacity of raw input or in other substantial change	<i>Identical baseline and projected sugar output levels; cf. Baseline vs. Project data in Emission Reductions spreadsheet.</i>



<p>(4) The biomass used by the project facility are not stored for more than one year;</p>	<p>The cane bagasse, leaves and woodchips will not be stored longer than a few months, since integrally consumed within the milling season.</p>	<p><i>No projected storage of biomass except for operating buffer; cf. EPC specifications and Project data in Emission Reductions spreadsheet.</i></p>
<p>(5) The biomass used by the project facility are not obtained from chemically processed biomass (e.g. through esterification, fermentation, hydrolysis, pyrolysis, bio- or chemical degradation, etc.) prior to combustion. Moreover, the preparation of biomass-derived fuel do not involve significant energy quantities, except from transportation or mechanical treatment so as not to cause significant GHG emissions;</p>	<p>No chemical process is involved in the biomass preparation prior to combustion:</p> <ul style="list-style-type: none"> - Bagasse is directly fed from the crushing mills to the boilers, without any new transformation process, - Leaves will be shredded before combustion, - Woodchips will be burnt untreated. 	<p><i>Biomass supply description; cf. final EIA report's Project activity description.</i></p>
<p>(6) In the case of fuel switch project activities, the use of biomass or the increase in the use of biomass as compared to the baseline scenario is technically not possible at the project site without a capital investment in:</p> <ul style="list-style-type: none"> • The retrofit or replacement of existing heat generators/boilers; or • The installation of new heat generators/boilers; or • A new dedicated biomass residues supply chain established for the purpose of the project (e.g. collecting and cleaning contaminated new sources of biomass residues that could otherwise not be used for energy purposes); or • Equipment for preparation and feeding of biomass residues. 	<p>Not applicable as no fuel switch is at stake in Amatikulu CPA.</p>	<p><i>N/A</i></p>
<p>(7) In the case that biogas is used in power and/or heat generation, this methodology is applicable under the following conditions:</p> <ul style="list-style-type: none"> • The biogas is generated by anaerobic digestion of wastewater (to be) registered as a CDM project activity and the details of the registered CDM project activity must be included in the PDD. Any CERs from biogas energy generation should be claimed under the proposed project activity registered under this methodology; • The biogas is generated by anaerobic digestion of wastewater that is not (and 	<p>Not applicable as no biogas recovery for power or heat generation is envisaged in Amatikulu CPA.</p>	<p><i>N/A</i></p>



will not) be registered as a CDM project activity. The amount of biogas does not exceed 50% of the total fuel fired on an energy basis.		
<p>(8) In the case of biomass from dedicated plantations:</p> <p>(a) The cultivated land can be clearly identified and used only for dedicated energy biomass plantations;</p> <p>(b) The CDM project activity does not lead to a shift of pre-project activities outside the project boundary, i.e. the land under the proposed project activity can continue to provide at least the same amount of goods and services as in the absence of the project;</p> <p>(c) The plantations are established:</p> <p>(i) On land which was, at the start of the project implementation, classified as degraded or degrading; or</p> <p>(ii) On a land area that is included in the project boundary of one or several registered A/R CDM project activities;</p> <p>(d) The plantations are not established on organic soil (notably peatlands);</p> <p>(e) The land area of the dedicated plantations will be planted by direct planting and/or seeding;</p> <p>(f) After harvest, regeneration will occur either by direct planting, seeding or natural sprouting;</p> <p>(g) Grazing will not occur within the plantation;</p> <p>(h) No irrigation is undertaken for the biomass plantations;</p> <p>(i) The land area where the dedicated plantation will be established is, prior to project implementation, severely degraded and in absence of the CDM project activity would have not been used for any other agricultural or forestry activity;</p> <p>(j) Only perennial plantations are eligible.</p>	Not applicable as no biomass from dedicated plantations is envisaged in Amatikulu CPA.	N/A

Finally, the methodology is applicable since the most plausible baseline scenario, as identified per the “Selection of the baseline scenario and demonstration of additionality” section D.4 hereunder, is:

- For power generation: Scenarios P3 and P7.
- For heat generation: Scenario H4.

- No heat generated by the project activity is converted to mechanical power through steam turbines for mechanical power generation, thus no alternative scenarios for mechanical power.
- For biomass residue use: Scenario B4.

In addition to the applicability conditions of ACM0006, Amatikulu CPA also meets the applicability conditions of the following tools and standardized baseline:

Tool for the demonstration and assessment of additionality (Version 07.0.0):

All potential alternative scenarios to the proposed project activity included in the additionality assessment and available to project participants cannot be implemented in parallel to the proposed project activity.

Tool to calculate the emission factor for an electricity system (Version 04.0):

This tool is applicable for Amatikulu CPA as it will export electricity of the grid.

Standardized baseline | Grid emission factor for the Southern African power pool (Version 01.0):

This standardized baseline is applicable to the CDM project activity as:

- Amatikulu CPA takes place in the Republic of South Africa, a SAPP member country;
- Amatikulu CPA is connected to the project electricity system;
- The CDM approved methodology that is applied to Amatikulu CPA requires to determine CO₂ emission factor for the project electricity system through the application of the tool, for the determination of baseline emissions, project emissions and leakage emissions; and
- As Amatikulu CPA uses the ex ante option of data vintage, as per the tool, the latest approved values of this standardized baseline is used for calculation of emission reduction for the entire first crediting period.

D.3. Sources and GHGs

According to methodology ACM0006, the spatial extent of the project boundary encompasses:

- All plants generating power and/or heat located at the project site, whether fired with biomass, fossil fuels or a combination of both;
- All power plants connected physically to the electricity system (grid) that the project plant is connected to;
- The means of transportation of biomass to the project site;
- The site where the biomass residues would have been left for decay or dumped;

The main emission sources and type of GHGs in the project boundary are listed in the table below:

Table 4: Emissions sources and greenhouse gases included in the proposed CPA boundary

Source		Gas	Included?	Justification / Explanation
Baseline	Electricity and heat generation	CO ₂	Included	Main emission source
		CH ₄	Excluded	Excluded for simplification. This is conservative
		N ₂ O	Excluded	Excluded for simplification. This is conservative
	Uncontrolled burning or decay of surplus biomass	CO ₂	Excluded	It is assumed that CO ₂ emissions from surplus biomass residues do not lead to changes of carbon pools in the LULUCF sector
		CH ₄	Excluded	For conservativeness reasons, project participants decided not to include this emission source.



	residues	N ₂ O	Excluded	Excluded for simplification. This is conservative. Note also that emissions from natural decay of biomass are not included in GHG inventories as anthropogenic sources
Project Activity	On-site fossil fuel consumption	CO ₂	Included	May be an important emission source
		CH ₄	Excluded	Excluded for simplification. This emission source is assumed to be very small
		N ₂ O	Excluded	Excluded for simplification. This emission source is assumed to be very small
	Off-site transportation of biomass	CO ₂	Included	May be an important emission source
		CH ₄	Excluded	Excluded for simplification. This emission source is assumed to be very small
		N ₂ O	Excluded	Excluded for simplification. This emission source is assumed to be very small
	Combustion of biomass for electricity and heat	CO ₂	Excluded	It is assumed that CO ₂ emissions from surplus biomass do not lead to changes of carbon pools in the LULUCF sector
		CH ₄	Excluded	This emission source is not included because CH ₄ emissions from uncontrolled burning or decay of biomass in the baseline scenario are not included.
		N ₂ O	Excluded	Excluded for simplification. This emission source is assumed to be small
	Storage of biomass	CO ₂	Excluded	It is assumed that CO ₂ emissions from surplus biomass do not lead to changes of carbon pools in the LULUCF sector
		CH ₄	Excluded	Excluded for simplification. Since biomass are stored for not longer than one year, this emission source is assumed to be small
		N ₂ O	Excluded	Excluded for simplification. This emissions source is assumed to be very small
	Wastewater from the treatment of biomass	CO ₂	Excluded	It is assumed that CO ₂ emissions from surplus biomass do not lead to changes of carbon pools in the LULUCF sector
		CH ₄	Excluded	No additional waste water from the treatment of biomass residues is expected, let alone treated under anaerobic conditions
		N ₂ O	Excluded	Excluded for simplification. This emission source is assumed to be small
Cultivation of land to produce biomass feedstock	CO ₂	Excluded	Not applicable as no biomass from dedicated plantation is used	
	CH ₄	Excluded	Not applicable as no biomass from dedicated plantation is used	
	N ₂ O	Excluded	Not applicable as no biomass from dedicated plantation is used	

Emissions sources and GHGs included in the project boundary

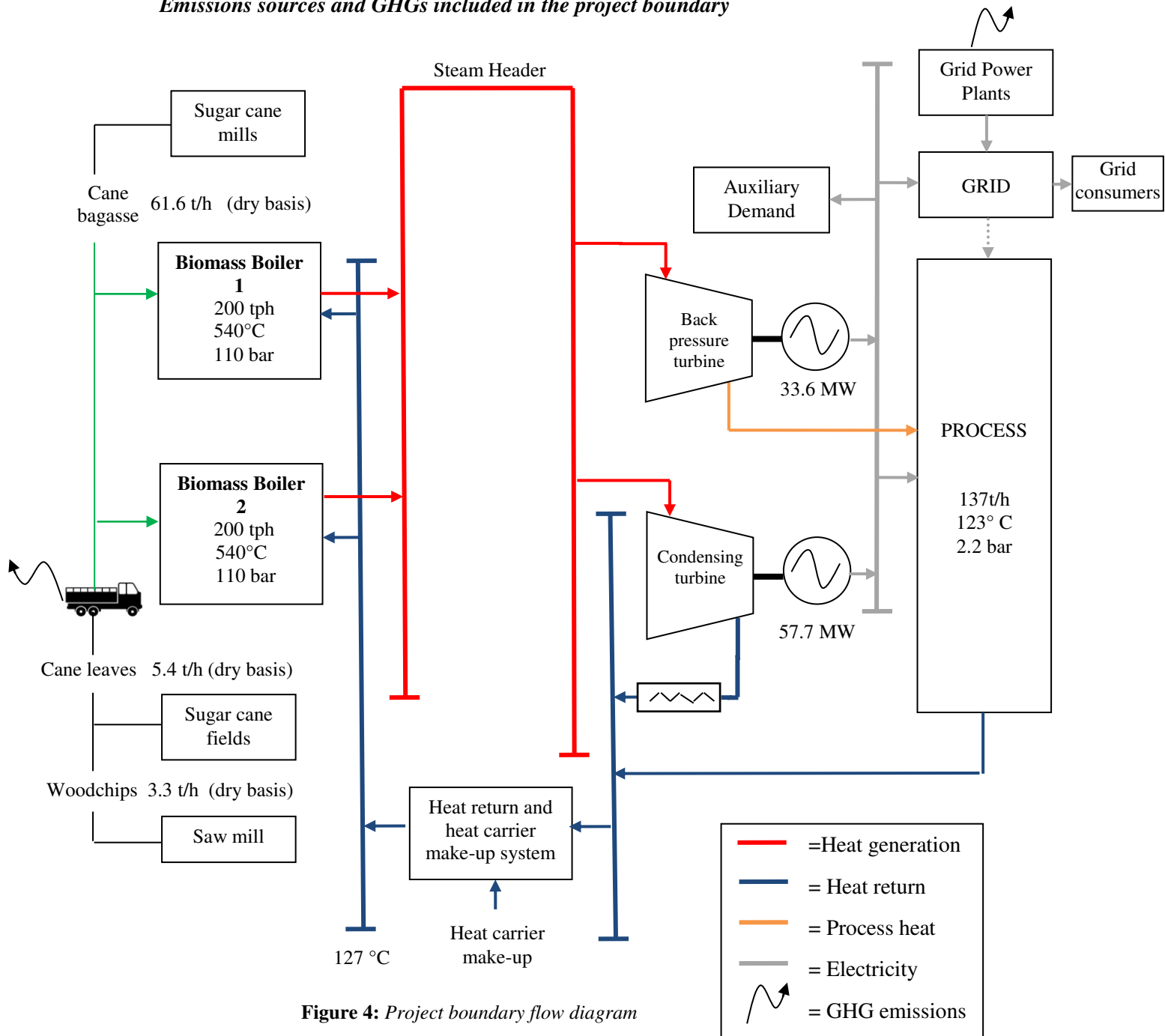

Figure 4: Project boundary flow diagram

D.4. Description of the baseline scenario

Step 1: Identification of alternative scenarios

Sub-step 1a: Definition of alternative scenarios to the proposed CDM project activity

Alternative scenarios for electric power:

Description of alternative scenarios	Plausible and credible alternative?	Rationale												
<p>The proposed project activity not undertaken as a CDM project activity;</p> <table border="1" data-bbox="279 488 807 680"> <tr> <td><i>Turbo capacity</i></td> <td><i>33.6 MW</i></td> <td><i>57.7 MW</i></td> </tr> <tr> <td><i>Type</i></td> <td><i>Back pressure</i></td> <td><i>Condensing Extraction</i></td> </tr> <tr> <td><i>Steam consumption</i></td> <td><i>3.58 kg/kWh</i></td> <td><i>4.61 kg/kWh</i></td> </tr> <tr> <td><i>Configuration</i></td> <td colspan="2"><i>Cogeneration</i></td> </tr> </table> <p>(i.e. a high efficiency biomass residues co-generation plant to generate extra power for greater autonomy and export to the grid)</p>	<i>Turbo capacity</i>	<i>33.6 MW</i>	<i>57.7 MW</i>	<i>Type</i>	<i>Back pressure</i>	<i>Condensing Extraction</i>	<i>Steam consumption</i>	<i>3.58 kg/kWh</i>	<i>4.61 kg/kWh</i>	<i>Configuration</i>	<i>Cogeneration</i>		<p>YES</p>	<p>The project activity is credible although not likely to occur in the absence of the CDM due to major barriers (see Step 2 below).</p>
<i>Turbo capacity</i>	<i>33.6 MW</i>	<i>57.7 MW</i>												
<i>Type</i>	<i>Back pressure</i>	<i>Condensing Extraction</i>												
<i>Steam consumption</i>	<i>3.58 kg/kWh</i>	<i>4.61 kg/kWh</i>												
<i>Configuration</i>	<i>Cogeneration</i>													
<p>If applicable, the continuation of power generation in existing power plants at the project site;</p> <p><i>The existing plants would operate at the same conditions (e.g. installed capacities, average load factors, or average energy efficiencies, fuel mixes, and equipment configuration) as those observed in the most recent three years prior to the starting date of the CDM project activity;</i></p>	<p>NO</p>	<p>Not plausible since in the absence of the project the power plant will operate with different conditions to those observed in the most recent three years prior to the starting date of the project activity because of increased sugar cane supply.</p>												
<p>If applicable, the continuation of power generation in existing power plants at the project site.</p> <table border="1" data-bbox="279 1346 687 1480"> <tr> <td><i>Turbo capacity</i></td> <td><i>12 MW</i></td> </tr> <tr> <td><i>Type</i></td> <td><i>Back pressure</i></td> </tr> <tr> <td><i>Efficiency</i></td> <td><i>8.1 kg/kWh</i></td> </tr> <tr> <td><i>Configuration</i></td> <td><i>Cogeneration</i></td> </tr> </table> <p><i>The existing plants would operate with different conditions from those observed in the most recent three years prior to the starting date of the CDM project activity;</i></p>	<i>Turbo capacity</i>	<i>12 MW</i>	<i>Type</i>	<i>Back pressure</i>	<i>Efficiency</i>	<i>8.1 kg/kWh</i>	<i>Configuration</i>	<i>Cogeneration</i>	<p>YES</p>	<p>P3 is a possible baseline scenario, since bagasse residues are the cheapest fuel available at the project site and the existing low efficiency cogeneration unit would be enough to cover the sugar factory expanded electricity needs, as is the prevailing practice in Sub-Saharan Africa's sugar industry.</p> <p>This scenario is in accordance with the technical description of the baseline plant in Section A.5.</p>				
<i>Turbo capacity</i>	<i>12 MW</i>													
<i>Type</i>	<i>Back pressure</i>													
<i>Efficiency</i>	<i>8.1 kg/kWh</i>													
<i>Configuration</i>	<i>Cogeneration</i>													
<p>If applicable, the retrofitting of existing power plants at the project site;</p> <p><i>The retrofitting may or may not include a change in fuel mix;</i></p>	<p>NO</p>	<p>Not credible as in the absence of the project the power plant would be enough to cover the sugar factory expanded electricity needs and no retrofit would be necessary or justified. As stated above, the current power plant is able to operate for at least 15 more years.</p> <p>In connection with heat alternative H3, mills electrification and other energy efficiency modifications would need to</p>												

Description of alternative scenarios	Plausible and credible alternative?	Rationale
		be carried to allocate enough steam from the existing heat generation processes to the increased sugar cane supply, thus the power plant would require a small additional turbo-alternator and/or higher importing capabilities from the grid. This is not realistic because more costly and technically challenging than P3 & H4 combination alternative, let alone that a higher grid dependency is strategically not desirable.
P5 The installation of new power plants at the project site different from those installed under the CDM project activity;	NO	Not plausible as no new power plant whatsoever would be envisaged if not the project activity one or the continuation of the existing one under different conditions. Indeed, no other source of energy (neither fossil nor renewable) would be attractive compared to the readily available biomass residues identified, which is the only source of energy part of Tongaat Hulett core business.
P6 The generation of power in specific off-site plants, excluding the power grid;	NO	Not credible as there are no off-site plants neither existing nor planned to be built near the project site.
P7 The generation of power in the power grid.	YES	Feasible given the national high-voltage power line which is reliable and under permanent expansion (though heavily fossil-dominated).

Alternative scenarios for heat:

Description of alternative scenarios	Plausible and credible alternative?	Rationale								
<p data-bbox="284 1608 737 1671">The proposed project activity not undertaken as a CDM project activity;</p> <table border="1" data-bbox="284 1711 796 1870"> <tr> <td data-bbox="293 1711 485 1742"><i>Boiler capacity</i></td> <td data-bbox="485 1711 796 1742"><i>2 x 200 tph</i></td> </tr> <tr> <td data-bbox="293 1742 485 1774"><i>Specifications</i></td> <td data-bbox="485 1742 796 1774"><i>540°C @110 bar</i></td> </tr> <tr> <td data-bbox="293 1774 485 1805"><i>Efficiency</i></td> <td data-bbox="485 1774 796 1805"><i>94 %</i></td> </tr> <tr> <td data-bbox="293 1805 485 1870"><i>Fuel mix</i></td> <td data-bbox="485 1805 796 1870"><i>Bagasse, leaves and woodchips</i></td> </tr> </table> <p data-bbox="284 1910 804 2009">(i.e. a high efficiency biomass residues co-generation plant to generate extra power for greater autonomy and export to the grid)</p>	<i>Boiler capacity</i>	<i>2 x 200 tph</i>	<i>Specifications</i>	<i>540°C @110 bar</i>	<i>Efficiency</i>	<i>94 %</i>	<i>Fuel mix</i>	<i>Bagasse, leaves and woodchips</i>	YES	The project activity is feasible although not likely to occur in the absence of the CDM due to major barriers (see Step 2 below)
<i>Boiler capacity</i>	<i>2 x 200 tph</i>									
<i>Specifications</i>	<i>540°C @110 bar</i>									
<i>Efficiency</i>	<i>94 %</i>									
<i>Fuel mix</i>	<i>Bagasse, leaves and woodchips</i>									

Description of alternative scenarios	Plausible and credible alternative?	Rationale								
<p>If applicable, the continuation of heat generation in existing plants at the project site;</p> <p>H2 <i>The existing plants would operate at the same conditions (e.g. installed capacities, average load factors, or average energy efficiencies, fuel mixes, and equipment configuration) as those observed in the most recent three years prior to the starting date of the CDM project activity;</i></p>	<p>NO</p>	<p>Not plausible since in the absence of the project the plant would operate with a necessary higher steam generation capacity and conditions than those observed in the most recent three years prior to the starting date of the project activity because of increased sugar cane supply.</p>								
<p>If applicable, the continuation of heat generation in existing plants at the project site;</p> <p>H3 <i>The existing plants would operate with different conditions from those observed in the most recent three years prior to the starting date of the CDM project activity;</i></p>	<p>NO</p>	<p>Not plausible since in the absence of the project the plant would operate with a necessary higher steam generation capacity and conditions than those observed in the most recent three years prior to the starting date of the project activity because of increased sugar cane supply.</p> <p>In connection with power alternative P4, matching the existing heat generation to the increased sugar cane supply steam requirements by electrifying the mills and carrying energy efficiency modifications would result in an insufficient boiler capacity to burn all of the bagasse generated. This is not realistic because the enormous surplus of bagasse would need to be trucked away and disposed of in a landfill at prohibitive expenses.</p> <p>The traditional outlet for surplus fibre (namely paper manufacture) would not be able to deal with the size of the generated surplus (as the paper mill in the area has already started limiting the amount of fibre taken from sugar mills due to oversupply), neither would a wasteful and environmentally unfriendly dedicated bagasse incinerator.</p>								
<p>If applicable, the retrofitting of existing plants at the project site;</p> <p>H4</p> <table border="1" data-bbox="284 1883 798 2013"> <tr> <td><i>Boiler capacity</i></td> <td><i>4*42+85 + 37.5 tph</i></td> </tr> <tr> <td><i>Specifications</i></td> <td><i>370°C @32 bar</i></td> </tr> <tr> <td><i>Efficiency</i></td> <td><i>81.8 %</i></td> </tr> <tr> <td><i>Fuel mix</i></td> <td><i>Bagasse</i></td> </tr> </table>	<i>Boiler capacity</i>	<i>4*42+85 + 37.5 tph</i>	<i>Specifications</i>	<i>370°C @32 bar</i>	<i>Efficiency</i>	<i>81.8 %</i>	<i>Fuel mix</i>	<i>Bagasse</i>	<p>YES</p>	<p>H4 is a possible baseline scenario, since bagasse residues are the cheapest fuel available at the project site and the existing low efficiency cogeneration unit would be enough to cover the sugar factory expanded steam needs, as is the prevailing practice in Sub-Saharan</p>
<i>Boiler capacity</i>	<i>4*42+85 + 37.5 tph</i>									
<i>Specifications</i>	<i>370°C @32 bar</i>									
<i>Efficiency</i>	<i>81.8 %</i>									
<i>Fuel mix</i>	<i>Bagasse</i>									

Description of alternative scenarios	Plausible and credible alternative?	Rationale
<i>The retrofitting may or may not include a change in fuel mix;</i>		Africa's sugar industry. This scenario is in accordance with the technical description of the baseline plant in Section A.5.
H5 The installation of new plants at the project site different from those installed under the CDM project activity;	NO	Not plausible as no new plant whatsoever would be envisaged if not the project activity one or the retrofit of the existing one to accommodate for the sugar factory expanded steam demand. Indeed, no other source of energy (neither fossil nor renewable) would be attractive compared to the readily available biomass residues identified, which is the only source of energy part of Tongaat Hulett core business.
H6 The generation of heat in specific off-site plants;	NO	Not credible as there is no off-site heat-generating plants neither existing nor planned to be built near the project site.
H7 The generation of heat from district heating.	NO	Not credible as there is no district heating available in this area of South Africa.

No mechanical power through steam turbine(s) is generated in the project activity as the prime movers will be electrified.

Alternative scenarios for the use of biomass residues:

Description of alternative scenarios	Plausible and credible alternative?	Rationale
B1 The biomass residues are dumped or left to decay mainly under aerobic conditions. <i>This applies, for example, to dumping and decay of biomass residues on fields;</i>	NO	<i>Cane bagasse, cane leaves & wood chips:</i> Not applicable as no biomass residues are dumped or left to decay prior to their use under the project activity



Description of alternative scenarios	Plausible and credible alternative?	Rationale
<p>The biomass residues are dumped or left to decay under clearly anaerobic conditions.</p> <p>B2 <i>This applies, for example, to landfills which are deeper than 5 meters. This does not apply to biomass residues that are stock-piled or left to decay on fields;</i></p>	NO	<p><i>Cane bagasse, cane leaves & wood chips:</i> Not applicable as no biomass residues are dumped or left to decay prior to their use under the project activity</p>
<p>The biomass residues are burnt in an uncontrolled manner without utilizing it for energy purposes;</p> <p>B3</p>	YES	<p><i>Cane leaves & wood chips:</i> B3 is a possible baseline scenario for cane leaves and wood chips, since it is the common practise for cane leaves to be burnt in fields and excess sawmill waste to be burnt for destruction (see additional details below the biomass residues Table). <i>Cane bagasse:</i> B3 is not a possible baseline scenario for cane bagasse, as it is already all used for power and heat generation at the project site.</p>
<p>The biomass residues are used for power or heat generation at the project site in new and/or existing plants;</p> <p>B4</p>	YES	<p><i>Cane bagasse:</i> B4 is a possible baseline scenario for cane bagasse since it is the cheapest fuel available at the project site as a by-product of the sugar mill operations and it is already combusted in the existing plant for the sugar mill energy needs. <i>Cane leaves & wood chips:</i> B4 is not a possible baseline scenario for cane leaves and wood chips, as available bagasse is enough to suit the consumption of existing or retrofitted plant at the project site. Besides, current practise dominantly burns cane leaves in fields and destructs excess saw mill waste (see additional details below the biomass residues Table).</p>
<p>The biomass residues are used for power or heat generation at other sites in new and/or existing plants;</p> <p>B5</p>	NO	<p><i>Cane bagasse, cane leaves & wood chips:</i> Not plausible, as the sources of the biomass residues and their fate in the absence of the project activity are clearly identified above. Current practise predominantly burns cane leaves in fields and destructs excess saw mill waste (see additional details below the biomass residues Table).</p>
<p>The biomass residues are used for other energy purposes, such as the generation of biofuels;</p> <p>B6</p>	NO	<p><i>Cane bagasse:</i> Not plausible as the bagasse, already being a by-product of sugar production processes, have no more potential use for other energy purposes such as generation of biofuels and it</p>

Description of alternative scenarios	Plausible and credible alternative?	Rationale
		is already combusted in the existing plant for the sugar mill energy needs. <i>Cane leaves & wood chips:</i> Not plausible, as the sources of the biomass residues and their fate in the absence of the project activity are clearly identified above. Current practise predominantly burns cane leaves in fields and destructs excess saw mill waste (see additional details below the biomass residues Table).
B7 The biomass residues are used for non-energy purposes, e.g. as fertilizer or as feedstock in processes (e.g. in the pulp and paper industry);	NO	<i>Cane bagasse, cane leaves & wood chips:</i> Not plausible, as the sources of the biomass residues and their fate in the absence of the project activity are clearly identified above. Current practise predominantly burns cane leaves in fields and destructs excess saw mill waste (see additional details below the biomass residues Table).
B8 Biomass residues are purchased from a market, or biomass residues retailers, or the primary source of the biomass residues and/or their fate in the absence of the CDM project activity cannot be clearly identified.	NO	<i>Cane bagasse, cane leaves & wood chips:</i> Not applicable as (i) no market of such capacity exists in the region; moreover (ii) the primary source of the biomass residues and their fate in the absence of the project activity are clearly identified above.

The baseline scenario for the use of biomass residues should be separately identified for different categories of biomass residues, covering the whole amount of biomass residues supposed to be used in the CDM project activity during the crediting period, and consistent with the alternative scenarios selected for power and heat generation (scenarios P and H above):

Biomass residues category (k)	Biomass residues type	Biomass residues source	Biomass residues fate in the absence of the CDM project activity	Biomass residues use in project scenario	Biomass residues quantity (dry basis)
1	Cane bagasse	On-site production	Power and heat generation on-site (B4)	Power and heat cogeneration on-site	372,674 tons/y
2	Cane leaves	On-site cultivation	Burnt in an uncontrolled manner (B3)	Power and heat cogeneration on-site	32,627 tons/y
3	Sawmill waste	Forestry industry	Burnt in an uncontrolled manner (B3)	Power and heat cogeneration on-site	19,931 tons/y

For biomass residues categories for which scenarios B1, B2 or B3 is deemed a plausible baseline alternative, project participants shall demonstrate that this is a realistic and credible alternative scenario:

Cane leaves

As a matter of fact, the sugarcane industry in South Africa burns 90% of its crop at harvest while 10% is harvested green, meaning that a vast majority of the cane leaves are usually burnt (as it reduces the costs

of harvesting, hauling and milling that benefits farmers and consumers). The South African Sugar Association (SASA) has actually established an Environmental Sub-committee that advises and regulates burning practices.

- ➔ Cane leaves, which sources are clearly identified by the project participants as internal to Amatikulu growers and harvesters, are burnt without energy generation prior to their use under the project activity, as per the regional prevailing practice.

Sawmill waste

The average annual mass of sawmill waste is estimated at 416 kilo tons in KwaZulu-Natal, where 77 sawmills are operating, accounting for about 18.5% of the national sawn-timber production (only the sawmill waste of the forestry industry is considered here, although there are even larger volumes of waste produced in the forest operations. It usually far exceeds the limited amounts of these by-products which find secondary uses in the pulp and paper, and the board production industries (Norris & Volschenk, 2007).

- ➔ Sawmill waste is in abundant surplus in the region of the project activity, and the project plant demand of 20 kilo tons per annum will have a negligible effect on the currently unused excess balance, far larger (> 25%) than the quantities utilized. Besides, prior to its use under the project activity, the sawmill waste was formerly burnt for destruction thus not collected or utilized.

Outcome of Sub-step 1a: List of plausible alternative scenarios to the project activity

Following the above analysis, the plausible alternative scenarios further considered are:

- For power generation: P1, P3 and P7
- For heat generation: H1 and H4
- For biomass residues: B3 and B4

Sub-step 1b: Consistency with mandatory applicable laws and regulations

The plausible alternative scenarios must be in compliance with all mandatory applicable laws and regulatory requirements. A review of their consistency with these laws and regulations is presented hereafter.

	Regulatory analysis	Consistency with laws & regulations?
P1 H1	<u>The proposed activity not undertaken under the CDM:</u> As the project activity legal due diligence demonstrates, this alternative scenario complies with all mandatory applicable legal and regulatory requirements.	YES
P3 H4	<u>The installation of new power plants at the project site different from those installed under the project activity:</u> This scenario, as described in Section A.5, is - similarly to the Project activity - compliant with all applicable laws & regulations.	YES
P7	<u>The generation of power in the power grid:</u> Current grid-connected power plants (and future capacity developments) operate under the control and responsibility of Eskom, the national utility body in compliance with the law.	YES
B3	<u>The biomass residues are burnt in an uncontrolled manner without utilizing it for energy purposes:</u> This scenario is in compliance with the law and already practised.	YES
B4	<u>The biomass residues are used for power or heat generation at the project site in new and/or existing plants:</u> As the project activity legal due diligence demonstrates, this alternative	YES

	scenario complies with all mandatory applicable legal and regulatory requirements.	
--	--	--

Outcome of Sub-step 1b: List of alternative scenarios to the project activity that are in compliance with mandatory legislation and regulations taking into account the enforcement in the region or country.

Following the above analysis, the plausible alternative scenarios compliant with mandatory legislation and regulations in force in South Africa are:

- For power generation: P1, P3 and P7
- For heat generation: H1 and H4
- For biomass residues: B3 and B4

Hence the following credible combinations of baseline scenarios still under consideration at this stage:

Baseline scenario			Description of the situation
Power	Heat	Biomass residues	
P1	H1	B4	<p><u>The proposed project activity, not undertaken as a CDM project activity:</u></p> <ul style="list-style-type: none"> - The installation of a high efficiency biomass residues co-generation plant to generate extra power for greater autonomy and export to the grid - The biomass residues are used for power or heat generation at the project site in the project activity plant.
P3 P7	H4	B3 B4	<p><u>The existing low efficiency, expanded cogeneration power plant:</u></p> <ul style="list-style-type: none"> - The production of power in the power grid AND the the continuation of power generation in existing power plant at the project site under different conditions - The retrofitting of the existing plant at the project site (low pressure boiler) - The biomass residues are used for power or heat generation at the project site in new plant AND burnt in an uncontrolled manner.

In compliance with the permitted selection between *Step 2 (Barrier analysis)* and *Step 3 (Investment analysis)* available in procedure for the “Selection of the baseline scenario and demonstration of additionality” described in the methodology and referred to in the PoA, the project proponents chose to proceed with *Step 2 (Barrier analysis)* only.

Step 2: Barrier analysis

This step serves to identify barriers and to assess which alternatives are prevented by these barriers.

Sub-step 2a: Identify barriers that would prevent the implementation of alternative scenarios

- **Barrier due to prevailing practice**

As per the Guidelines on additionality of First-of-its-kind Project activities (Version 02.0, EB 69), the proposed project activity is the First-of-its-kind in the applicable geographical area because:

- (a) **The project is the first in the applicable geographical area that applies a technology that is different from technologies that are implemented by any other project, which are able to deliver the same output and have started commercial operation in the applicable**

geographical area before the project design document (CDM-PDD) is published for global stakeholder consultation or before the start date of the proposed project activity, whichever is earlier;

Indeed, as shown in the table below, both the scale of the renewable power export to the grid and the level of performance of the steam boilers of the project activity verify the First-of-its-kind demonstration:

Applicable geographical area	Republic of South Africa ⁸	
Measure	Switch of technology with or without change of energy source including energy efficiency improvement as well as use of renewable energies (b)	
Output	Electricity for the grid	Steam for process/cogeneration
Different technologies	<p>Amatikulu power capacity differs to any other existing bagasse-to-power in the applicable geographical area by the size of installation (c).</p> <p>Indeed, as of the start date of Amatikulu project, no other large scale bagasse-to-power facility in South Africa has been commercially operating power units of more than 15 MW of electrical capacity each, let alone exporting to the grid in excess of this level, while Amatikulu power plant will feature two large-scale turbo-alternators of 33.6 MW and 57.7 MW and export an unprecedented 55.1 MW of power from biomass residues to the national grid (season-average).</p>	<p>Amatikulu project's steam boilers differ to any other existing steam generation technology in the applicable geographical area by the type of fuel (b).</p> <p>Indeed, as of the start date of Amatikulu project, no other sugar cane industrial have recovered neither cane leaves nor wood chips in substantial quantities for energy purposes in the country, while Amatikulu boilers will rely on an unprecedented fuel mix of 10% leaves (cane-based fuel balance) and 5% wood chips (total fuel balance), on energy basis.</p>
Evidence	<p>According to the Sugar Milling Research Institute (SMRI), no bagasse-to-power plant in South Africa has been commercially operating power units of more than 15 MW of electrical capacity each, and any electricity that is produced in excess of factory requirements for external use is well below this level. In fact, the largest installed single power unit in the South African sugarcane industry to date is a 12.5 MW unit at Malelane Mill (Mpumalanga province).</p> <p>Furthermore, as explained by SA Sugar Association's executive director in an interview⁹, there are no large-scale biomass power exporting facilities to the grid in RSA (>15 MW dedicated to power export): "Sugar milling operations are already powered by internally generated energy, namely steam and electricity, fuelled by burning sugar cane bagasse in on-site furnaces. However, these</p>	<p>According to the Sugar Milling Research Institute (SMRI), none of the sugarcane industry players in South Africa has recovered cane leaves in substantial quantities for energy purposes to date, let alone wood chips. In spite of growing environmental pressure to stop burning cane on field, 91.2% of the sugar cane fields are still burnt before harvesting. Most of the remaining leaves are stripped off and left in the fields before transport to the mill.</p>

⁸ According to the Guidelines, the applicable geographical area should be the entire host country, which already includes 14 sugar mills.

⁹ <http://www.farmersweekly.co.za/article.aspx?id=10940&h=Can-South-Africa-run-on-sugar-power>

	<p>mills are designed to operate at low energy-generation efficiency to match the available bagasse fuel supply with their energy needs. This is necessary to avoid bagasse stockpiling in the absence of viable electricity markets.</p> <p>Some of the 14 sugar mills already have a capacity beyond their power needs and already export about 5MW into the national grid at marginal income. This capacity can be increased significantly for a large-scale contribution to the grid, but it requires a viable market to support the very significant capital investment required.”</p>	
--	---	--

These first-of-its-kind characteristics have been confirmed by the Sugar Milling Research Institute based on their periodic assessment and publication of Sugar Factory Plant Installations in South Africa, as endorsed in a statement dated August 28, 2012 which was provided to the DOE.

(b) The project implements one or more of the measures;

The proposed project implements measure (b): Switch of technology with or without change of energy source including energy efficiency improvement as well as use of renewable energies.

(c) Project participants selected a crediting period for the project activity that is “a maximum of 10 years with no option of renewal”;

Indeed, as stated in section A.9.2 above, the Project participants selected a fixed crediting period of 10 years, with no option of renewal.

- **Technological barriers**

According to Bosch Projects (responsible for Amatikulu CPA Front End Engineering Design) during a meeting with the DOE, the unprecedented implementation of 110 bar high-pressure boilers in the sugarcane industry results in significant technical challenges and constraints including:

- higher water treatment requirements,
- higher Operation & Maintenance skills needs,
- higher contamination risks in heat exchange process.

Based on research findings on Boilers, boiler fuel and boiler efficiency (Wienese, 2002), a boiler is the single most expensive item in a sugar factory. Because of the high operating pressure and temperature, it is also one of the potentially most dangerous pieces of equipment. For these reasons alone proper boiler control is imperative.

On the other hand, common practice steam boilers in the country don't exceed 70 bars, with an average of rather 30-40 bars¹⁰, as revealed by an Alstom Power - John Thompson Boiler Division study, spanning across South Africa and Sub-Saharan Africa, which encompassed both fire-tube and water-tube boilers with a further subdivision of water tube boilers into sugar and non-sugar boilers (Mcintyre, 2002): “Out of 133 boilers inspected over a time frame of 4 years, it revealed the reasonably representative general situation as follows:

- fire-tube boilers covered a steam production range of 1-20 t/hr at pressures from 10 to 20 bar,

¹⁰ SMRI statement confirmed that the most common level of sugarcane boiler pressure in South Africa is 31 bars.

- water tube boilers encountered in the analysis are mainly in the 35-200 t/hr range and usually operate around 30-40 bar,
- some low-pressure units (13 bar) were found as were higher pressure 70 bar boilers from the utilities and paper industry.”

Conclusion: The proposed project activity, identified as the First-of-its-kind, is **additional**.

Sub-step 2b: Eliminate alternative scenarios which are prevented by the identified barriers

While the above-listed barriers would prevent the proposed project activity without the CDM, the continuation of the existing cogeneration unit expanded to solely meet the sugar mill needs would not be affected by such barriers because of no technology novelty and the lower investment required. The following table summarizes whether or not the alternative scenarios are prevented by the identified barriers, in the light of the above analysis.

Table 5: Barrier analysis

	The proposed project activity without the CDM (P1 + H1 + B4)	The existing low efficiency, expanded cogeneration plant (P3/P7 + H4 + B3/B4)
Prevailing practice barrier	YES	NO
Technological barriers	YES	NO
Conclusion	There is at least one significant barrier that prevents implementation of the proposed project activity without the CDM.	There is no significant barrier that prevents the medium efficiency cogeneration plant.

Outcome of Step 2b: List of alternative scenarios to the project activity that are not prevented by any barrier.

Baseline scenario			Description of the situation
Power	Heat	Biomass residues	
P3 P7	H4	B3 B4	<p><u>The existing low efficiency, expanded cogeneration power plant:</u></p> <ul style="list-style-type: none"> - The production of power in the power grid AND the continuation of power generation in existing power plant at the project site under different conditions - The retrofitting of the existing plant at the project site (low pressure boiler) - The biomass residues are used for power or heat generation at the project site in new plant AND burnt in an uncontrolled manner.

According to the methodology ACM0006:

*If there is only one alternative scenario that is not prevented by any barrier, and if this alternative is not the proposed project activity undertaken without being registered as a CDM project activity, then **this alternative scenario is identified as the baseline scenario**.*

➔ Therefore, the baseline scenario is identified as the only alternative scenario that is not prevented by any barrier: the existing low efficiency, expanded cogeneration power plant.

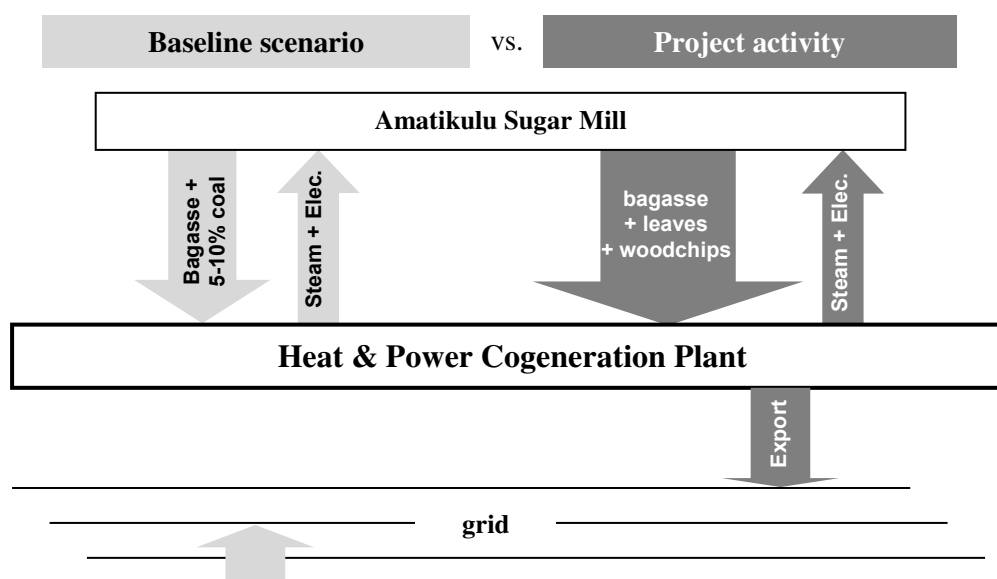

Figure 5: Baseline vs. Project activity simplified comparative diagram

Note: as required by the methodology, the capacities of heat and electricity generation, including the grid, considered in the baseline scenario are able to deliver the same level of process heat and power generation as that of the project scenario. For a detailed description of the identified baseline scenario (parameters, data and sources), please refer to section A.5 “Technical description of the CPA”.

Step 4: Common practice analysis

There are no other activities that are operational and that are similar to Amatikulu CPA in South Africa, as it was demonstrated above to be the first-of-its-kind. Therefore, the proposed project type has not diffused in the relevant region.

Conclusion: similar activities cannot be observed; therefore the proposed CPA is additional.

D.5. Demonstration of eligibility for a CPA

The CPA is eligible for inclusion in the PoA as it verifies all applicability assessments below.

Eligibility criteria		
Category	N°	Description
Boundary and location of the CPA	a	The geographical boundary of the CPA is within the Republic of South Africa, in consistency with the geographical boundary set in the PoA.
		How each generic CPA meets the eligibility criteria? Location and boundary are stated in the specific CPA-DD, confirming that the industrial facility is located in South Africa. Mean of proof / Evidence Document: - Specifications of equipment supply/civil works (Bosch Projects Front End Engineering Design - May 2012 EPC document); - EIA report (September 2012) GPS coordinates confirm the project location mentioned in the CPA-DD. Tick when met: <input checked="" type="checkbox"/>
Double counting avoidance	b.1	The CPA is neither already included in another PoA, nor developed as a stand-alone CDM project.
		How each generic CPA meets the eligibility criteria?

Eligibility criteria		
Category	N°	Description
		<p>The CME review confirms that the CPA is not already included in another PoA or developed as a stand-alone CDM project.</p> <p>Mean of proof / Evidence Document:</p> <ul style="list-style-type: none"> - The review of UNFCCC and DNA registries/portfolios did not detect any similar activities; and - The CME project assessment and interview confirmed that the proposed CPA is not registered or under validation under the Clean Development Mechanism of the UNFCCC or any voluntary scheme as a single project activity or as a component activity under another program. <p>Tick when met: <input checked="" type="checkbox"/></p>
	b.2	<p>The industrial facility included in the CPA is uniquely identified.</p> <p>How each generic CPA meets the eligibility criteria?</p> <p>The proposed CPA is uniquely identified and defined in an unambiguous manner by amongst other aspects providing geographic information.</p> <p>Mean of proof / Evidence Document:</p> <p>The CME project assessment and interview confirmed that the proposed CPA is uniquely identified and defined in an unambiguous manner by amongst other aspects providing geographic information (GPS location).</p> <p>Tick when met: <input checked="" type="checkbox"/></p>
Technology/measure specifications		<p>he level and type of service provided by the CPA technology/measure design (in comparison with the baseline system being replaced), as well as its capacity, key feature and performance, comply with the PoA eligible technologies/measures as described in Section A.6.</p>
	c.1	<p>How each generic CPA meets the eligibility criteria?</p> <p>The technology and measures taken are clearly described in the CPA-DD and in line with the technology definition in the PoA-DD.</p> <p>Mean of proof / Evidence Document:</p> <ul style="list-style-type: none"> - Biomass residues management and power-and-heat technologies including their performance and technical specifications are specified in CPA-DD.Specifications of equipment supply/civil works (Bosch Projects Front End Engineering Design - May 2012 EPC document). <p>Tick when met: <input checked="" type="checkbox"/></p>
	c.2	<p>The technology/measure implemented within the CPA complies with national and/or international testing/certification requirements.</p> <p>How each generic CPA meets the eligibility criteria?</p> <p>The CPA implementer will meet applicable testing or certification standard in the industry and at national level such as Energy Efficiency measurement and verification standard SATS 50010:2010, in addition to applicable permitting requirements among:</p> <ul style="list-style-type: none"> - Environmental authorisation (EIA) - Waste licence - Air emissions licence - Water storage and use authorisation - Electricity generation licence - Compliance with the grid connection code - Pressure vessel registration - Stack height compliance - Approval of building plans <p>Mean of proof / Evidence Document:</p> <ul style="list-style-type: none"> - EIA report (September 2012); - Specifications for equipment supply (Bosch Projects Front End



Eligibility criteria		
Category	N°	Description
		Engineering Design - May 2012 EPC document); - Statement in the CPA-DD. Tick when met: <input checked="" type="checkbox"/>
CPA start date	d	The starting date of the CPA is verifiable through documentary evidence and is not prior to the start of PoA validation.
		How each generic CPA meets the eligibility criteria? The CPA-DD determines the start date based on implementation, construction or real action start. Mean of proof / Evidence Document: Supporting documentary evidence for the starting date is provided and described in CPA-DD section A.8.1. Tick when met: <input checked="" type="checkbox"/>
Compliance and application of the methodology ACM0006	e	The proposed CPA meets the applicability criteria and other requirements of the latest version of ACM0006 as outlined in section II.B.2. of the PoA-DD.
		How each generic CPA meets the eligibility criteria? The CPA-DD shall demonstrate in its section D.2 that all applicability criteria and requirements of ACM0006 methodology are verified. Mean of proof / Evidence Document: Applicability conditions' related evidence in CPA-DD section D.2 Table 3 confirm and support the applicability of the methodology. Tick when met: <input checked="" type="checkbox"/>
CPA additionality	f	The CPA is additional, in compliance with the relevant requirements pertaining to the demonstration of additionality (step-by-step additionality demonstration of ACM0006 methodology) as outlined in section II.B.4. of the PoA-DD.
		How each generic CPA meets the eligibility criteria? The CPA successfully applies in its section D.4 the step-by-step additionality demonstration of ACM0006 methodology. Mean of proof / Evidence Document: Additionality demonstration related analysis and supporting evidence above confirm and support the additionality of the CPA. Tick when met: <input checked="" type="checkbox"/>
Undertaking of local stakeholder consultations and environmental impact analysis	g.1	A local stakeholder consultation has been conducted prior to the inclusion of the CPA.
		How each generic CPA meets the eligibility criteria? The CPA-DD details the proceedings of the stakeholder consultation in its section C. Mean of proof / Evidence Document: Stakeholder consultation attendance sheet and comments in EIA report (September 2012). Tick when met: <input checked="" type="checkbox"/>
	g.2	If applicable, an environmental impact analysis has been conducted prior to the inclusion of the CPA.
		How each generic CPA meets the eligibility criteria? The CPA-DD outlines the EIA requirements and provides details on the EIA process/outcome in its section B. Mean of proof / Evidence Document: EIA report (September 2012). If applicable, tick when met: <input checked="" type="checkbox"/> Tick if not applicable: <input type="checkbox"/>



Eligibility criteria		
Category	N°	Description
Non-diversion of ODA in case of Public funding	h	Confirmation that the CPA does not involve any public funding from Annex I Parties or that in case public funding is used, it does not result in diversion of Official Development Assistance (ODA)
		How each generic CPA meets the eligibility criteria? The CPA-DD confirms that the CPA does not involve any public funding or that in case public funding is used a confirmation that official development assistance is not being diverted to the implementation of the PoA. Mean of proof / Evidence Document: CPA-DD section A.11 statement. Tick when met: <input checked="" type="checkbox"/>
Supplemental eligibility criteria required by the CME		
Awareness and agreement of those operating a CPA on PoA subscription	1	The CPA is either implemented by the Coordinating/managing entity or by another entity that acknowledges its participation in the PoA.
		How each generic CPA meets the eligibility criteria? The CPA-DD shall state the name of the CPA implementer and shall confirm that it is the CME or that a binding agreement has been signed with the CME, which ensures that CPA implementer is aware and agrees that its project activity is subscribed to a PoA. Mean of proof / Evidence Document: Binding agreement signed between the CPA implementer and the CME. Tick when met: <input checked="" type="checkbox"/>
Approval of CPA by CME	2	The CPA-DD has been reviewed by the Coordinating/managing entity and submitted to a DOE for inclusion into the PoA.
		How each generic CPA meets the eligibility criteria? The CPA implementer shall submit a CPA-DD to the CME with all underlying evidence for review. If the conclusion of CME review is positive, the CME shall notify the CPA implementer of the submission of the CPA-DD to the DOE for inclusion. Otherwise conclusion of the CME review shall be sent to the CPA implementer Mean of proof / Evidence Document: Communication from the CME to the DOE (cc/ CPA implementer) submitting the proposed CPA-DD for inclusion into the PoA. Tick when met: <input checked="" type="checkbox"/>
Crediting period	3	The crediting period of the CPA shall not exceed the length of the PoA (i.e. 28 years) regardless of the time of inclusion of CPA in the PoA.
		How each generic CPA meets the eligibility criteria? The CPA-DD verifies that the crediting period of the CPA does not exceed the length of the PoA. Mean of proof / Evidence Document: CPA implementer's statement and chosen crediting period in CPA-DD section A.9. Tick when met: <input checked="" type="checkbox"/>
CER ownership	4	The CPA is either implemented by the Coordinating/managing entity or by another entity that relinquishes its carbon rights to the CME.
		How each generic CPA meets the eligibility criteria? The CPA-DD shall states confirm that the CPA implementer has signed a binding agreement with the CME, which ensures that CPA implementer is aware and agrees that its carbon rights have to be relinquished to CME. Mean of proof / Evidence Document:

Eligibility criteria		
Category	N°	Description
		Binding agreement signed by CPA implementer and the CME. Tick when met: <input checked="" type="checkbox"/>

D.6. Estimation of emission reductions

D.6.1. Explanation of methodological choices

The following equations are used to calculate emission reductions, baseline emissions, project emissions and leakage of the CPA:

$$ER_y = BE_y - PE_y - LE_y \quad (1)$$

Where:

ER_y	=	Emissions reductions in year y (tCO ₂)
BE_y	=	Baseline emissions in year y (tCO ₂)
PE_y	=	Project emissions in year y (tCO ₂)
LE_y	=	Leakage emissions in year y (tCO ₂)

Baseline Emissions

$$BE_y = EL_{BL,GR,y} \cdot EF_{EG,GR,y} + \sum_f FF_{BL,HG,y,f} \cdot EF_{FF,y,f} + EL_{BL,FF/GR,y} \cdot \min(EF_{EG,GR,y}, EF_{EG,FF,y}) + BE_{BR,y} \quad (2)$$

Where:

BE_y	=	Baseline emissions in year y (tCO ₂)
$EL_{BL,GR,y}$	=	Baseline minimum electricity generation in the grid in year y (MWh)
$EF_{EG,GR,y}$	=	Grid emission factor in year y (tCO ₂ /MWh)
$FF_{BL,HG,y,f}$	=	Baseline fossil fuel demand for process heat in year y (GJ)
$EF_{FF,y,f}$	=	CO ₂ emission factor for fossil fuel type f in year y (tCO ₂ /GJ)
$EL_{BL,FF/GR,y}$	=	Baseline uncertain electricity generation in the grid or on-site in year y (MWh)
$EF_{EG,FF,y}$	=	CO ₂ emission factor for electricity generation with fossil fuels at the project site in the baseline in year y (tCO ₂ /MWh)
$BE_{BR,y}$	=	Baseline emissions due to disposal of biomass residues in year y (tCO ₂ e)
y	=	Year of the crediting period
f	=	Fossil fuel type

Step 1: Determine biomass availability, generation and capacity constraints, efficiencies and power emission factors in the baseline

Step 1.1: Determine total baseline process heat generation

The amount of process heat that would be generated in the baseline in year y ($HC_{BL,y}$) is determined as the difference of the enthalpy of the process heat (steam or hot water) supplied to process heat loads in the CDM project activity minus the enthalpy of the feed-water, the boiler blow-down and any condensate return to the heat generators.

However, as detailed in Step 3 and Step 4 below, the project owners have decided to conservatively neglect emission reductions arising from displacement of heat. Therefore, only electricity related emission reductions will be monitored and claimed.

Step 1.2: Determine total baseline electricity generation

$$EL_{BL,y} = EL_{PJ,gross,y} + EL_{PJ,imp,y} - EL_{PJ,aux,y} \quad (3)$$

Where:

$EL_{BL,y}$	=	Baseline electricity generation in year y (MWh)
$EL_{PJ,gross,y}$	=	Gross quantity of electricity generated in all power plants which are located at the project site and included in the project boundary in year y (MWh)
$EL_{PJ,imp,y}$	=	Project electricity imports from the grid in year y (MWh)
$EL_{PJ,aux,y}$	=	Total auxiliary electricity consumption required for the operation of the power plants at the project site in year y (MWh)
y	=	Year of the crediting period

$EL_{PJ,aux,y}$ includes all electricity required for the operation of equipment related to the preparation, storage and transport of biomass (e.g. for mechanical treatment of the biomass, conveyor belts, driers, etc.) and electricity required for the operation of all power or heat generating plants which are located at the project site and included in the project boundary (e.g. for pumps, fans, cooling towers, instrumentation and control, etc.).

Step 1.3: Determine baseline capacity of electricity generation

The total capacity of electricity generation available in the baseline should be calculated using the equation below. The heat engines i and j should be obtained from the baseline scenario identified using the “Selection of the baseline scenario and demonstration of additionality” and the load factors should take into account seasonal operational constraints as well as other technical constraints in the system (e.g. availability of heat to drive heat engines).

$$CAP_{EG,total,y} = LOC_y \cdot \left[\sum_i (CAP_{EG,CG,i} \cdot LFC_{EG,CG,i}) + \sum_j (CAP_{EG,PO,j} \cdot LFC_{EG,PO,j}) \right] \quad (4)$$

Where:

$CAP_{EG,total,y}$	=	Baseline electricity generation capacity in year y (MWh)
$CAP_{EG,CG,i}$	=	Baseline electricity generation capacity of heat engine i (MW)
$CAP_{EG,PO,j}$	=	Baseline electricity generation capacity of heat engine j (MW)
$LFC_{EG,CG,i}$	=	Baseline load factor of heat engine i (ratio)
$LFC_{EG,PO,j}$	=	Baseline load factor of heat engine j (ratio)
LOC_y	=	Length of the operational campaign in year y (hour)
i	=	Cogeneration-type heat engine in the baseline scenario
j	=	Power-only-type heat engine in the baseline scenario
y	=	Year of the crediting period

Step 1.4: Determine the baseline availability of biomass residues

Where the baseline scenario includes the use of biomass residues for the generation of power and/or heat, the amount of biomass residues of category n that would be available in the baseline in year y ($BR_{B4,n,y}$) has to be determined.

- The cane bagasse that would be used in the baseline for the generation of power and heat is accounted accordingly as $BR_{B4,n,y}$.

Step 1.5: Determine the efficiencies of heat generators, and efficiencies and heat-to-power ratio of heat engines

The efficiencies of heat generators and heat engines are calculated using the following option:

Option 3: The efficiencies of heat generators and heat engines are determined based on the historical records, as follows:

Efficiency for heat generators

The efficiency for heat generators should be calculated using the following equation:

$$\eta_{BL,HG,BR,h} = \text{MAX} \left\{ \frac{HG_{BR,h,x}}{\sum_n BR_{n,h,x} \cdot NCV_{BR,n,x}}; \frac{HG_{BR,h,x-1}}{\sum_n BR_{n,h,x-1} \cdot NCV_{BR,n,x-1}}; \frac{HG_{BR,h,x-2}}{\sum_n BR_{n,h,x-2} \cdot NCV_{BR,n,x-2}} \right\} \quad (5)$$

Where:

$\eta_{BL,HG,BR,h}$	=	Baseline biomass-based heat generation efficiency of heat generator h (ratio)
$HG_{BR,h,x}$	=	Net quantity of heat generated from using biomass residues in heat generator h in year x (GJ/yr)
$BR_{n,h,x}$	=	Quantity of biomass residues of category n used in heat generator h in year x (tonnes on dry-basis)
$NCV_{BR,n,x}$	=	Net calorific value of biomass residues of category n in year x (GJ/tonnes on dry-basis)
x	=	Last calendar year prior to the start of the crediting period
n	=	Biomass residue category
h	=	Heat generator in the baseline scenario

If fossil fuels and biomass residues were used for heat generation in the heat generator h prior to the implementation of the CDM project activity, then $HG_{BR,h,x}$, $HG_{BR,h,x-1}$ and $HG_{BR,h,x-2}$, as well as $HG_{FF,h,x}$, $HG_{FF,h,x-1}$ and $HG_{FF,h,x-2}$, are determined as follows:

$$HG_{BR,h,x} = HG_{h,x} \cdot \frac{\sum_n BR_{n,h,x} \cdot NCV_{BR,n,x}}{\sum_n BR_{n,h,x} \cdot NCV_{BR,n,x} + \sum_f FF_{f,h,x} \cdot NCV_{FF,f,x}} \quad (6)$$

$$HG_{FF,h,x} = HG_{h,x} \cdot \frac{\sum_f FF_{f,h,x} \cdot NCV_{FF,f,x}}{\sum_n BR_{n,h,x} \cdot NCV_{BR,n,x} + \sum_f FF_{f,h,x} \cdot NCV_{FF,f,x}} \quad (7)$$

Where:

$HG_{BR,h,x}$	=	Net quantity of heat generated from using biomass residues in heat generator h in year x (GJ/yr)
$HG_{FF,h,x}$	=	Net quantity of heat generated from using fossil fuels in heat

		generator h in year x (GJ/yr)
$HG_{h,x}$	=	Net quantity of heat generated in heat generator h in year x (GJ/yr)
$BR_{n,h,x}$	=	Quantity of biomass residues of category n used in heat generator h in year x (tonnes on dry-basis)
$FF_{f,h,x}$	=	Quantity of fossil fuel type f fired in heat generator h in year x (mass or volume unit/yr)
$NCV_{BR,n,x}$	=	Net calorific value of biomass residues of category n in year x (GJ/tonnes on dry-basis)
$NCV_{FF,f,x}$	=	Net calorific value of fossil fuel type f in year x (GJ/mass or volume unit)

Efficiency for heat engines

The efficiency for heat engines is calculated using the following equation:

$$\eta_{BL,EG,PO,i/j} = \text{MAX} \left\{ \frac{EL_{BR,PO,x,i/j}}{HG_{BR,PO,x,i/j}}; \frac{EL_{BR,PO,x-1,i/j}}{HG_{BR,PO,x-1,i/j}}; \frac{EL_{BR,PO,x-2,i/j}}{HG_{BR,PO,x-2,i/j}} \right\} \quad (8)$$

Where:

$\eta_{BL,EG,CG,i}$	=	Baseline electricity generation efficiency of heat engine i (MWh/GJ)
$\eta_{BL,EG,PO,j}$	=	Average electric power generation efficiency of heat engine j (MWh/GJ)
$EL_{BR,CG/PO,x,i/j}$	=	Quantity of electricity generated in heat engine i/j in year x (MWh)
$HG_{BR,CG/PO,x,i/j}$	=	Quantity of heat used in heat engine i/j in year x (GJ)
x	=	Last calendar year prior to the start of the crediting period
i	=	Cogeneration-type heat engine in the baseline scenario
j	=	Power-only-type heat engine in the baseline scenario

The heat-to-power ratio of cogeneration-type heat engine (backpressure steam turbines) is calculated as follows.

Case 1: For existing heat engines with a minimum three-year operational history prior to the project activity:

$$\text{HPR}_{BL,EG,CG/PO,i/j} = \frac{1}{3.6} \cdot \text{MAX} \left\{ \frac{HC_{BR,CG/PO,x,i/j}}{EL_{BR,CG/PO,x,i/j}}; \frac{HC_{BR,CG/PO,x-1,i/j}}{EL_{BR,CG/PO,x-1,i/j}}; \frac{HC_{BR,CG/PO,x-2,i/j}}{EL_{BR,CG/PO,x-2,i/j}} \right\} \quad (9)$$

Where:

$\text{HPR}_{BL,i}$	=	Baseline heat-to-power ratio of the heat engine i (ratio)
$HC_{BR,CG/PO,x,i/j}$	=	Quantity of process heat extracted from the heat engine i/j in year x (GJ)
$EL_{BR,CG/PO,x,i/j}$	=	Quantity of electricity generated in heat engine i/j in year x (MWh)
x	=	Last calendar year prior to the start of the crediting period
i	=	Cogeneration-type heat engine in the baseline scenario
j	=	Power-only-type heat engine in the baseline scenario

Step 1.6: Determine the emission factor of on-site electricity generation with fossil fuels

- Since no fossil fuel based power generation was conservatively accounted for as part of the baseline scenario, $EF_{EG,FF,y} = EF_{EG,GR,y}$.

Step 1.7: Determine the emission factor of grid electricity generation

The parameter $EF_{EG,GR,y}$ is determined as the combined margin CO₂ emission factor for grid to which the CDM project activity is connected in year y , using the latest approved version of the “Standardized baseline: Grid emission factor for the Southern African power pool”.

Step 2: Determine the minimum baseline electricity generation in the grid

$$EL_{BL,GR,y} = \max(0, EL_{BL,y} - CAP_{EG,total,y}) \quad (10)$$

Where:

$EL_{BL,GR,y}$	=	Baseline minimum electricity generation in the grid in year y (MWh)
$EL_{BL,y}$	=	Baseline electricity generation in year y (MWh)
$CAP_{EG,total,y}$	=	Baseline electricity generation capacity in year y (MWh)
y	=	Year of the crediting period

Step 3: Determine the baseline biomass-based heat and power generation

As the methodology allows to reflect given specific site conditions, the allocation of the biomass-based heat is biased by a particular technical constraint associated to existence of direct-drive mechanical turbines in the baseline, which consume 78.6 tph of high-pressure steam without cogeneration of electricity and are not accounted anymore in the project’s process steam demand due to the prime movers electrification. Besides, several other energy efficiency measures as described in section A.5. further improve the process steam consumption in the project, accentuating the gap between process steam demand in baseline¹¹ and project scenarios.

- As a conservative way of simplification, the project owners have decided to neglect emission reductions arising from displacement of heat. Therefore, only electricity related emission reductions will be monitored and claimed.

Step 4: Determine the baseline demand for fossil fuels to meet the balance of process heat and the corresponding electricity generation

In consequence of Step 3 bias highlighted above (prime movers electrification technical constraint), baseline supplemental co-firing of coal at 5-10% is conservatively neglected, as well as baseline uncertain electricity generation in the grid or on-site is conservatively neglected (although marginal power imports from the grid and occasional coal consumption on site do actually occur in the identified baseline as well as in the historical situation prior to the implementation of the project).

In order to compensate for the baseline prime movers steam consumption discount, the project electrified prime movers power consumption (4.5 MW load equivalent to 26,244 MWh/y) are discounted from the project net electricity generation by conservative inclusion in the total auxiliary electricity consumption

¹¹ Where the existing back-pressure turbo alternator operating at full capacity has sufficient power generation to satisfy the sugar mill – and supplemental co-firing of coal at 5-10% when bagasse supply interruption and maintenance.

($EL_{PJ,aux,y}$) although the more efficient use of electricity within the sugar factory (efficient motors, variable frequency drives, etc) is expected to save back part of it.

- $FF_{BL,HG,y,f} = EL_{BL,FF/GR,y} = 0$

→ As a conservative way of simplification, the project owners have decided to neglect emission reductions arising from displacement of heat. Therefore, only electricity related emission reductions will be monitored and claimed.

Step 5: Determine the baseline emissions due to uncontrolled burning or decay of biomass residues

→ Project participants decided not to include these emission sources. Therefore, $BE_{BR,y} = 0$.

Step 6: Calculate baseline emissions

$$BE_y = EL_{BL,GR,y} \cdot EF_{EG,GR,y}$$

Project emissions

$$PE_y = PE_{FF,y} + PE_{GR1,y} + PE_{GR2,y} + PE_{TR,y} + PE_{BR,y} + PE_{WW,y} + PE_{BG2,y} + PE_{BC,y} \quad (11)$$

Where:

PE_y = Project emissions in year y (tCO₂)

$PE_{FF,y}$ = Emissions during the year y due to fossil fuel consumption at the project site (tCO₂)

$PE_{GR1,y}$ = Emissions during the year y due to grid electricity imports to the project site (tCO₂)

$PE_{GR2,y}$ = Emissions due to a reduction in electricity generation at the project site as compared to the baseline scenario in year y (tCO₂)

$PE_{TR,y}$ = Emissions during the year y due to transport of biomass to the project plant (tCO₂)

$PE_{BR,y}$ = Emissions from the combustion of biomass during the year y (tCO₂e)

$PE_{WW,y}$ = Emissions from wastewater generated from the treatment of biomass in year y (tCO₂e)

$PE_{BG2,y}$ = Emissions from the production of biogas in year y (tCO₂e)

$PE_{BC,y}$ = Project emissions associated with the cultivation of land to produce biomass in the year y (tCO₂e)

Determination of $PE_{FF,y}$

CO₂ emissions from fossil fuel combustion in process j are calculated based on the quantity of fuels combusted and the CO₂ emission coefficient of those fuels, as follows:

$$PE_{FC,j,y} = \sum_i FC_{i,j,y} \times COEF_{i,y} \quad (12)$$

$PE_{FC,j,y}$ = Are the CO₂ emissions from fossil fuel combustion in process j during the year y (tCO₂/yr);

$FC_{i,j,y}$ = Is the quantity of fuel type i combusted in process j during the year y (mass or volume unit/yr);

$COEF_{i,y}$ = Is the CO₂ emission coefficient of fuel type i in year y (tCO₂/mass or volume unit)

i = Are the fuel types combusted in process j during the year y

- No on-site fossil fuel consumption is foreseen, given the unlikely default of both the biomass residues supply to the cogeneration power plant and the back-up grid delivery connexion simultaneously¹², therefore $\underline{PE_{FE,y} = 0}$.

Determination of $PE_{GR1,y}$

If electricity is imported from the grid to the project site during year y , corresponding emissions should be accounted for as project emissions, as follows:

$$PE_{GR1,y} = EF_{EG,GR,y} \cdot EL_{PJ,imp,y} \quad (13)$$

Where:

$PE_{GR1,y}$	=	Emissions during the year y due to grid electricity imports to the project site (tCO ₂)
$EL_{PJ,imp,y}$	=	Project electricity imports from the grid in year y (MWh)
$EF_{EG,GR,y}$	=	Grid emission factor in year y (tCO ₂ /MWh)

- Amatikulu sugar mill imports marginal quantities of grid electricity during its weekly maintenance outages as well as during off-season for lighting and safety equipments; corresponding project emissions are accounted for accordingly. .

Determination of $PE_{GR2,y}$

$$PE_{GR2,y} = EF_{EG,GR,y} \cdot EL_{PJ,offset,y} \quad (14)$$

Where:

$PE_{GR2,y}$	=	Emissions due to a reduction in electricity generation at the project site as compared to the baseline scenario in year y (tCO ₂)
$EF_{EG,GR,y}$	=	Grid emission factor in year y (tCO ₂ /MWh)
$EL_{PJ,offset,y}$	=	Electricity that would be generated in the baseline that exceeds the generation of electricity during year y (MWh)

- The amount of electricity generated on-site in the baseline does not exceed the amount of electricity generated in the project scenario, therefore $\underline{PE_{GR2,y} = 0}$.

Determination of $PE_{TR,y}$

Option B: Using conservative default values

$$\left. \frac{PE_{TR,y}}{LE_{TR,y}} \right\} = \sum_f D_{f,y} \cdot FR_{f,y} \cdot EF_{CO2,f} \cdot 10^{-6} \quad (15)$$

Where:

¹² Actually, backup diesel generators are used only to keep critical equipment operating (control system, etc.) and in exceptional situations (initial start up) but definitely not used to provide any process heating load or to generate any export electricity, thus not CDM project-related but dependent on Amatikulu sugar mill operations in both the baseline and the project. The use of coal, although occasionally co-fired at 5-10% in baseline in case of bagasse supply interruption and maintenance, is not intended anymore in the Project thanks to alternative biomass residues sources, and will be limited to operational emergencies not exceeding 48 hours at a time. Besides, the three-wheeled cane loader expected to handle the biomass residues has an estimated gasoil consumption of 5.5 litres per hour of operation, amounting to less than 30,000 litres/year. Overall these insignificant fuel consumptions result in emissions well below the 1% of the overall expected average annual emissions reductions' negligibility threshold and can therefore be neglected.

$PE_{TR,y}$	=	Project emissions from transportation of freight in year y (tCO ₂)
$D_{f,y}$	=	Return trip distance between the origin and destination of freight transportation activity f in year y (km)
$EF_{CO_2,f}$	=	Default CO ₂ emission factor for freight transportation activity f (g CO ₂ / t km)
$FR_{f,y}$	=	Total mass of freight transported in freight transportation activity f in year y (t)
f	=	Freight transportation activities conducted in the project activity in year y

- Since the additional biomass residues (cane leaves and wood chips) used in the project activity are transported from the fields and the saw mill where they would have been burnt, corresponding project emissions are accounted for accordingly.

Determination of $PE_{BR,y}$

If project proponents chose to include emissions due to uncontrolled burning or decay of biomass residues ($BE_{BR,y}$) in the calculation of baseline emissions, then emissions from the combustion of biomass residues have also to be included in the project scenario. Otherwise, this emission source need not be included.

- Emissions due to uncontrolled burning or decay of biomass residues ($BE_{BR,y}$) were not included in the calculation of baseline emissions, therefore **$PE_{BR,y} = 0$** .

Determination of $PE_{WW,y}$

This emission source should be estimated in cases where wastewater originating from the treatment of the biomass is (partly) treated under anaerobic conditions and where methane from the waste water is not captured and flared or combusted.

- There is no additional wastewater originating from the treatment of the biomass therefore **$PE_{WW,y} = 0$** .

Determination of $PE_{BG2,y}$

No biogas recovery is covered under the PoA thus no project emissions associated with the production of biogas are applicable.

Determination of $PE_{BC,y}$

No biomass from dedicated plantation is used under the PoA thus no project emissions associated with the use of biomass from dedicated plantation are applicable.

Reduced Project emissions equation:

$$PE_y = (PE_{FF,y}) + PE_{GRI,y} + PE_{TR,y}$$

Leakage

The baseline scenarios for biomass residues for which this potential leakage is relevant are B5:, B6:, B7: and B8:.

- No biomass scenarios for biomass residues used in the Project activity are subject to leakage, therefore **$LE_v = 0$** .

D.6.2. Data and parameters that are to be reported ex-ante

The following are not monitored data and parameters:

- **Baseline emissions parameters not monitored**

Data / Parameter	Biomass categories and quantities used for the selection of the baseline scenario selection and assessment of additionality					
Unit	- Type (i.e. bagasse, rice husks, empty fruit bunches, etc.); - Source (e.g. produced on-site, obtained from an identified biomass residues producer, obtained from a biomass residues market, from dedicated plantations etc.); - Fate in the absence of the CDM project activity (scenarios B); - Use in the project scenario (scenarios P); - Quantity (tonnes on dry-basis)					
Description	Explain and document transparently in the CDM-PDD, using a table similar to Table 2, which quantities of which biomass categories are used in which installation(s) under the CDM project activity and what is their baseline scenario. The last column of Table 2 corresponds to the quantity of each category of biomass (tonnes). For the selection of the baseline scenario and demonstration of additionality, at the validation stage, an <i>ex ante</i> estimation of these quantities should be provided					
Source of data	On-site assessment of biomass categories and quantities					
Value(s) applied	Biomass residues category (k)	Biomass residues type	Biomass residues source	Biomass residues fate in the absence of the CDM project activity	Biomass residues use in project scenario	Biomass residues quantity (dry basis)
	1	Cane bagasse	On-site production	Power and heat generation on-site (B4)	Power and heat cogeneration on-site	372,674 tons/y
	2	Cane leaves	On-site cultivation	Burnt in an uncontrolled manner (B3)	Power and heat cogeneration on-site	32,627 tons/y
	3	Sawmill waste	Forestry industry	Burnt in an uncontrolled manner (B3)	Power and heat cogeneration on-site	19,931 tons/y
Choice of data or Measurement methods and procedures	-					
Purpose of data	Selection of the baseline scenario and assessment of additionality					
Additional comment	-					

Data / Parameter	BR_{n,h,x}		
Unit	tonnes on dry-basis		
Description	Quantity of biomass residues of category <i>n</i> used in heat generator <i>h</i> in year <i>x</i>		
Source of data	On-site measurements		
Value(s) applied	2009	2010	2011
	205,922	156,761	193,178
Choice of data or Measurement methods and procedures	Use weight or volume meters. Adjust for the moisture content in order to determine the quantity of dry biomass. The quantity shall be cross-checked with the quantity of heat generated and any fuel purchase receipts (if available)		
Purpose of data	Calculation of baseline emissions		
Additional comment	Applicable to Option 3 of Step 1.5		

Data / Parameter	FF_{f,h,x}		
Unit	mass or volume unit/yr		
Description	Quantity of fossil fuel type <i>f</i> fired in heat generator <i>h</i> in year <i>x</i>		
Source of data	On-site measurements		
Value(s) applied	2009	2010	2011
	6,043	5,740	3,947
Choice of data or Measurement methods and procedures	Use weight or volume meters. Adjust for the moisture content in order to determine the quantity of dry biomass. The quantity shall be cross-checked with the quantity of heat generated and any fuel purchase receipts (if available). In case of volume meters use the fuel density to convert the measurement to mass basis		
Purpose of data	Calculation of baseline emissions		
Additional comment	Applicable to heat generators that were operated using fossil fuels at the project site for at least three calendar years prior the implementation of the CPA		

Data / Parameter	HG_{h,x}		
Unit	GJ		
Description	Net quantity of heat generated in heat generator <i>h</i> in year <i>x</i>		
Source of data	On-site measurements		
Value(s) applied	2009	2010	2011
	2,055,316	1,875,282	2,294,872
Choice of data or Measurement methods and procedures	This parameter should be determined as the difference of the enthalpy of the heat (steam or hot water) generated by the heat generators(s) minus the enthalpy of the feed-water, the boiler blow-down and any condensate return. The respective enthalpies should be determined based on the mass (or volume) flows, the temperatures and, in case of superheated steam, the pressure. Steam tables or appropriate thermodynamic equations may be used to calculate the enthalpy as a function of temperature and pressure		
Purpose of data	Calculation of baseline emissions		
Additional comment	Applicable to Option 3 of Step 1.5 if fossil fuels and biomass residues were used for heat generation in the heat generator <i>h</i> prior to the implementation of the project activity.		

Data / Parameter	HG_{BR,CG/PO,x,i,j}		
Unit	GJ		
Description	Quantity of heat used in heat engine <i>i/j</i> in year <i>x</i>		
Source of data	On-site measurements		
Value(s) applied	2009	2010	2011
	853,238	835,162	965,839
Choice of data or Measurement methods and procedures	This parameter should be determined as the difference of the enthalpy of the process heat (steam or hot water) generated by the heat generators(s) [in the CDM project activity, monitored during year <i>y</i> ,] minus the enthalpy of the feed-water, the boiler blow-down and any condensate return. The respective enthalpies should be determined based on the mass (or volume) flows, the temperatures and, in case of superheated steam, the pressure. Steam tables or appropriate thermodynamic equations may be used to calculate the enthalpy as a function of temperature and pressure		
Purpose of data	<i>Calculation of baseline emissions</i>		
Additional comment	Applicable to Option 3 of Step 1.5, although the project owners have decided to conservatively neglect emission reductions arising from displacement of heat. Therefore, this parameter is not utilized in actual ER calculation.		

Data / Parameter	HC_{BR,CG/PO,x,i,j}		
Unit	GJ		
Description	Quantity of process heat extracted from the heat engine <i>i/j</i> in year <i>x</i>		
Source of data	On-site measurements		
Value(s) applied	2009	2010	2011
	731,243	715,751	827,744
Choice of data or Measurement methods and procedures	This parameter should be determined as the difference of the enthalpy of the process heat (steam or hot water) supplied to process heat loads in the CDM project activity minus the enthalpy of the feed-water, the boiler blow-down and any condensate return to the heat generators. The respective enthalpies should be determined based on the mass (or volume) flows, the temperatures and, in case of superheated steam, the pressure. Steam tables or appropriate thermodynamic equations may be used to calculate the enthalpy as a function of temperature and pressure		
Purpose of data	<i>Calculation of baseline emissions</i>		
Additional comment	Applicable to Case 1 of Step 1.5, although the project owners have decided to conservatively neglect emission reductions arising from displacement of heat. Therefore, this parameter is not utilized in actual ER calculation.		



Data / Parameter	$EL_{BR,CG/PO,x,i/j}$		
Unit	MWh		
Description	Quantity of electricity generated in heat engine i/j in year x		
Source of data	On-site measurements		
Value(s) applied	2009	2010	2011
	33,561	32,850	37,990
Choice of data or Measurement methods and procedures	Electricity meters		
Purpose of data	Calculation of baseline emissions		
Additional comment	Applicable to Case 1 of Step 1.5		

Data / Parameter	$CAP_{EG,CG,i}$
Unit	MW
Description	Baseline electricity generation capacity of heat engine i
Source of data	On-site measurements or reference plant design parameters
Value(s) applied	12
Choice of data or Measurement methods and procedures	This parameter should reflect the design maximum electricity generation capacity (in MW) of the baseline heat engines i . It should be based on the installed capacity of the heat engines. Project participants should document transparently and justify in the CDM-PDD how this parameter was determined
Purpose of data	Calculation of baseline emissions
Additional comment	-

Data / Parameter	$LFC_{HG,h}$
Unit	Ratio
Description	Baseline load factor of heat generator h
Source of data	On-site measurements or reference plant design parameters
Value(s) applied	1
Choice of data or Measurement methods and procedures	This parameter should reflect the maximum load factor (i.e. the ratio between the ‘actual heat generation’ of the heat generator and its ‘design maximum heat generation’ along one year of operation) of the baseline heat generator h , taking into account downtime due to maintenance, seasonal operational patterns, and any other technical constraints. Project participants should document transparently and justify in the CDM-PDD how this parameter was determined (e.g. using historical records)
Purpose of data	<i>Calculation of baseline emissions</i>
Additional comment	The project owners have decided to conservatively neglect emission reductions arising from displacement of heat. Therefore, this parameter is not utilized in actual ER calculation.



Data / Parameter	$HPR_{BL,i}$
Unit	Ratio
Description	Baseline heat-to-power ratio of the heat engine <i>i</i>
Source of data	On-site measurements or reference plant design parameters
Value(s) applied	6.05
Choice of data or Measurement methods and procedures	-
Purpose of data	<i>Calculation of baseline emissions</i>
Additional comment	The project owners have decided to conservatively neglect emission reductions arising from displacement of heat. Therefore, this parameter is not utilized in actual ER calculation.

Data / Parameter	$LFC_{EG,CG,i}$
Unit	Ratio
Description	Baseline load factor of heat engine <i>i</i>
Source of data	On-site measurements or reference plant design parameters
Value(s) applied	0.875
Choice of data or Measurement methods and procedures	This parameter should reflect the maximum load factor (i.e. the ratio between the ‘actual electricity generation’ of the heat engine and its ‘design maximum electricity generation’ along one year of operation) of the baseline heat engine <i>i</i> . The actual electricity generation of the heat engine should be determined taking into account downtime due to maintenance, seasonal operational patterns, and any other technical constraints. Project participants should document transparently and justify in the CDM-PDD how this parameter was determined
Purpose of data	Calculation of baseline emissions
Additional comment	-



Data / Parameter	$NCV_{BR,n,x}$
Unit	GJ/tonnes on dry-basis
Description	Net calorific value of biomass residues of category n in year x
Source of data	Either conduct measurements or use accurate and reliable local or national data where available. Where such data is not available, use IPCC default net calorific values (country-specific, if available) if they are deemed to reasonably represent local circumstances. Choose the values in a conservative manner and justify the choice
Value(s) applied	14.5
Choice of data or Measurement methods and procedures	Measurements shall be carried out at reputed laboratories and according to relevant international standards
Purpose of data	Calculation of baseline emissions
Additional comment	Applicable to Option 3 of Step 1.5 The NCV is to be calculated for wet biomass as used in the heat generator (i.e. deducting the energy used for the evaporation of the water contained in the biomass residues).

Data / Parameter	$NCV_{FF,f,x}$
Unit	GJ/tonnes
Description	Net calorific value of fossil fuel type f in year x
Source of data	Either conduct measurements or use accurate and reliable local or national data where available. Where such data is not available, use IPCC default net calorific values (country-specific, if available) if they are deemed to reasonably represent local circumstances. Choose the values in a conservative manner and justify the choice
Value(s) applied	27,5
Choice of data or Measurement methods and procedures	Measurements shall be carried out at reputed laboratories and according to relevant international standards
Purpose of data	Calculation of baseline emissions
Additional comment	Applicable to Option 3 of Step 1.5 if fossil fuels and biomass residues were used for heat generation in the heat generator h prior to the implementation of the project activity.

- **Project emissions parameters not monitored**

Data / Parameter	$EF_{CO_2,f}$
Unit	g CO ₂ / t km
Description	Default CO ₂ emission factor for freight transportation activity <i>f</i>
Source of data	Default value
Value(s) applied	129
Choice of data or Measurement methods and procedures	Heavy vehicles
Purpose of data	Calculation of project/leakage emissions
Additional comment	Applicable to Option B of the determination of $PE_{TR,y}$

- **Grid emission factor parameters not monitored**

Data / Parameter	$EF_{EG,GR,y}$
Unit	tCO ₂ /MWh
Description	Combined margin CO ₂ emission factor for the project electricity system applicable to all project activities other than wind and solar for the first crediting period
Source of data	Standardized baseline
Value(s) applied	0.9644
Choice of data or Measurement methods and procedures	Grid emission factor for the Southern African power pool (Version 01.0)
Purpose of data	Calculation of baseline emissions
Additional comment	The values are valid for three years from the date of adoption of standardized baseline by the CDM Executive Board, provided that no legal restrictions for international electricity exchange between any of the SAPP member countries take effect after the adoption of the standardized baseline

D.6.3. Ex-ante calculation of emission reductions

- **Baseline Emissions**

Step 1: Determine biomass availability, generation and capacity constraints, efficiencies and power emission factors in the baseline

Step 1.1: Determine total baseline process heat generation

The project owners have decided to conservatively neglect emission reductions arising from displacement of heat. Therefore, this step is not applicable to the actual ER calculation.

Step 1.2: Determine total baseline electricity generation

(ii) Baseline electricity generation
$EL_{BL,y} = EL_{PJ,gross,y} + EL_{PJ,imp,y} - EL_{PJ,aux,y}$

	EL _{BL,y}	EL _{PJ,gross,y}	EL _{PJ,imp,y}	EL _{PJ,aux,y}
Units	MWh	MWh	MWh	MWh
2018	356,443	435,522	10,531	89,610
2019	356,443	435,522	10,531	89,610
2020	356,443	435,522	10,531	89,610
2021	356,443	435,522	10,531	89,610
2022	356,443	435,522	10,531	89,610
2023	356,443	435,522	10,531	89,610
2024	356,443	435,522	10,531	89,610
2025	356,443	435,522	10,531	89,610
2026	356,443	435,522	10,531	89,610
2027	356,443	435,522	10,531	89,610
TOTAL	3,564,428	4,355,220	105,308	896,100

Amatikulu sugar mill imports marginal quantities of grid electricity during its weekly maintenance outages (every Monday from 2 am to 4 pm) as well as during the 16 weeks-long off-season for lighting and safety equipments. This minimum grid-reliance is similarly reflected in the Project Emissions of the Renewable Energy Generation Facility, therefore transparent to the Project activity Emission Reductions.

Step 1.3: Determine baseline capacity of electricity generation

(iii) Baseline capacity of electricity generation

$$CAP_{EGtotal,y} = LOC_y \cdot \left(\sum CAP_{EGCG,i} \cdot LFC_{EGCG,i} + \sum CAP_{EGPO,j} \cdot LFC_{EGPO,j} \right)$$

	CAP _{EG,total}	LOC _y	CAP _{EG,CG,i}	LFC _{EG,CG,i}	CAP _{EG,PO,j}	LFC _{EG,PO,j}
Units	MWh	hours	MW	ratio	MW	ratio
2018	63,504	6,048	12.0	0.88	N/A	N/A
2019	63,504	6,048	12.0	0.88	N/A	N/A
2020	63,504	6,048	12.0	0.88	N/A	N/A
2021	63,504	6,048	12.0	0.88	N/A	N/A
2022	63,504	6,048	12.0	0.88	N/A	N/A
2023	63,504	6,048	12.0	0.88	N/A	N/A
2024	63,504	6,048	12.0	0.88	N/A	N/A
2025	63,504	6,048	12.0	0.88	N/A	N/A
2026	63,504	6,048	12.0	0.88	N/A	N/A
2027	63,504	6,048	12.0	0.88	N/A	N/A
TOTAL	635,040	-	-	-	-	-

Step 1.4: Determine the baseline availability of biomass residues (dry basis)

	BR _{PJ,n,y}	BR _{B4,bagasse,y}	BR _{B1/B3,leaves,y}	BR _{B1/B3,woodchips,y}	BR _{B5/B8,n,y}
Units	tons/y	tons/y	tons/y	tons/y	tons/y
2018	425,232	372,674	32,627	19,931	-
2019	425,232	372,674	32,627	19,931	-
2020	425,232	372,674	32,627	19,931	-
2021	425,232	372,674	32,627	19,931	-
2022	425,232	372,674	32,627	19,931	-
2023	425,232	372,674	32,627	19,931	-
2024	425,232	372,674	32,627	19,931	-
2025	425,232	372,674	32,627	19,931	-
2026	425,232	372,674	32,627	19,931	-
2027	425,232	372,674	32,627	19,931	-
TOTAL	4,252,316	3,726,739	326,266	199,311	-

Step 1.5: Determine the efficiencies of heat generators, and efficiencies and heat-to-power ratio of heat engines

a) Efficiencies of heat generators

$\eta_{BL,HG,BR,h}$	$\eta_{BL,HG,FF,h}$
ratio	ratio
81.8%	-

b) Efficiency of heat engines

$\eta_{BL,EG,CG,i}$
MWh/GJ
0.039

c) and Heat-to-Power Ratio

$HPR_{BL,i}$
ratio
6.05

Step 1.6: Determination of the emission factor of on-site electricity generation with fossil fuels

$$EF_{EG,FF,y} = EF_{EG,GR,y}$$

Step 1.7: Determination of the emission factor of grid electricity generation

$EF_{EG,GR,y}$
tCO ₂ /MWh
0.9644

Step 2: Determine the minimum baseline electricity generation in the grid

	(iv) Minimum baseline electricity generation in the grid		
	$EL_{BL,GR,y} = \max(0, EL_{BL,y} - CAP_{EG,total,y})$		
	$EL_{BL,GR,y}$	$EL_{BL,y}$	$CAP_{EG,total,y}$
Units	MWh	MWh	MWh
2018	292,939	356,443	63,504
2019	292,939	356,443	63,504
2020	292,939	356,443	63,504
2021	292,939	356,443	63,504
2022	292,939	356,443	63,504
2023	292,939	356,443	63,504
2024	292,939	356,443	63,504
2025	292,939	356,443	63,504
2026	292,939	356,443	63,504
2027	292,939	356,443	63,504
TOTAL	2,929,388	3,564,428	635,040

Step 3: Determine the baseline biomass-based heat and power generation

The project owners have decided to conservatively neglect emission reductions arising from displacement of heat. Therefore, this step is not applicable to the actual ER calculation.

Step 4: Determine the baseline demand for fossil fuels to meet the balance of process heat and the corresponding electricity generation

- $FF_{BL,HG,y,f} = EL_{BL,FF/GR,y} = 0$ (conservatively neglected).

Step 5: Determine the baseline emissions due to uncontrolled burning or decay of biomass residues

- $BE_{BR,y} = 0$ (conservatively neglected).

Step 6: Calculate baseline emissions

BE_y			
$BE_y = EL_{BL,GR,y} \cdot EF_{EG,GR,y}$			
	BE_y	EL_{BL,GR,y}	EF_{EG,GR,y}
Units	t CO₂e	MWh	t CO₂e/MWh
2018	282,510	292,939	0.9644
2019	282,510	292,939	0.9644
2020	282,510	292,939	0.9644
2021	282,510	292,939	0.9644
2022	282,510	292,939	0.9644
2023	282,510	292,939	0.9644
2024	282,510	292,939	0.9644
2025	282,510	292,939	0.9644
2026	282,510	292,939	0.9644
2027	282,510	292,939	0.9644
Total	2,825,100	2,929,388	

- **Project emissions**

PE_y				
$PE_y = (PE_{FF,y}) + PE_{GRI,y} + PE_{TR,y}$				
	PE_y	PE_{FF,y}	PE_{GRI,y}	PE_{TR,y}
Units	t CO₂e	t CO₂e	t CO₂e	t CO₂e
2018	12,558	0	10,156	2,403
2019	12,558	0	10,156	2,403
2020	12,558	0	10,156	2,403
2021	12,558	0	10,156	2,403
2022	12,558	0	10,156	2,403
2023	12,558	0	10,156	2,403
2024	12,558	0	10,156	2,403
2025	12,558	0	10,156	2,403
2026	12,558	0	10,156	2,403
2027	12,558	0	10,156	2,403
TOTAL	125,580	-	101,559	24,030

(ii) Project emissions electricity is imported from the grid to the project site ($PE_{GR1,y}$):

	$PE_{GR1,y} = EF_{EG,GR,y} * EL_{PJ,imp,y}$		
	$PE_{GR1,y}$	$EF_{EG,GR,y}$	$EL_{PJ,imp,y}$
Units	tCO ₂	t CO ₂ e/MWh	MWh
2018	10,156	0.9644	10,531
2019	10,156	0.9644	10,531
2020	10,156	0.9644	10,531
2021	10,156	0.9644	10,531
2022	10,156	0.9644	10,531
2023	10,156	0.9644	10,531
2024	10,156	0.9644	10,531
2025	10,156	0.9644	10,531
2026	10,156	0.9644	10,531
2027	10,156	0.9644	10,531
TOTAL	101,559		

(iii) Project emissions from transportation of the biomass residues ($PE_{TR,y}$):

	$PE_{TR,y} = \sum_f D_{f,y} \cdot FR_{f,y} \cdot EF_{CO_2,f} \cdot 10^{-6}$			(Option B)
	$PE_{TR,y}$	$FR_{f,y}$	$D_{f,y}$	$EF_{CO_2,f}$
Units	tCO ₂	tons	km	g CO ₂ / t km
2018	2,403	93,157	200	129
2019	2,403	93,157	200	129
2020	2,403	93,157	200	129
2021	2,403	93,157	200	129
2022	2,403	93,157	200	129
2023	2,403	93,157	200	129
2024	2,403	93,157	200	129
2025	2,403	93,157	200	129
2026	2,403	93,157	200	129
2027	2,403	93,157	200	129
TOTAL	24,030			

- **Leakage Emissions**

No leakage emissions are expected.

D.6.4. Summary of the ex-ante estimates of emission reductions

Year	Baseline emissions (t CO ₂ e)	Project emissions (t CO ₂ e)	Leakage (t CO ₂ e)	Emission reductions (t CO ₂ e)
2018	282,510	12,558	-	269,952
2019	282,510	12,558	-	269,952
2020	282,510	12,558	-	269,952
2021	282,510	12,558	-	269,952



2022	282,510	12,558	-	269,952
2023	282,510	12,558	-	269,952
2024	282,510	12,558	-	269,952
2025	282,510	12,558	-	269,952
2026	282,510	12,558	-	269,952
2027	282,510	12,558	-	269,952
Total	2,825,100	125,580	-	2,699,520
Total number of crediting years	10			
Annual average over the crediting period	282,510	12,558	-	269,952

D.7. Application of the monitoring methodology and description of the monitoring plan

D.7.1. Data and parameters to be monitored

- **Baseline emissions parameters monitored:**

Data / Parameter	Biomass categories and quantities used in the CDM project activity																													
Unit	<ul style="list-style-type: none"> - Type (i.e. bagasse, rice husks, empty fruit bunches, tree bark etc.); - Source (e.g. produced on-site, obtained from an identified biomass residues producer, obtained from a biomass residues market, dedicated plantations etc.); - Fate in the absence of the CDM project activity (scenarios B); - Use in the project scenario (scenarios P and H); - Quantity (tonnes on dry-basis) 																													
Description	<p>Explain and document transparently in the CDM-PDD, using a table similar to Table 2, which quantities of which biomass categories are used in which installation(s) under the CDM project activity and what is their baseline scenario.</p> <p>The last column of Table 2 corresponds to the quantity of each category of biomass (tonnes on dry-basis). These quantities should be updated every year of the crediting period as part of the monitoring plan so as to reflect the actual use of biomass in the project scenario. These updated values should be used for emissions reductions calculations.</p> <p>Along the crediting period, new categories of biomass (i.e. new types, new sources, with different fate) can be used in the CDM project activity. In this case, a new line should be added to the table. If those new categories are of the type B1:, B2: or B3:, the baseline scenario for those types of biomass residues should be assessed using the procedures outlined in the guidance provided in the procedure for the selection of the baseline scenario and demonstration of additionality</p>																													
Source of data	On-site measurements																													
Value(s) applied	<table border="1"> <thead> <tr> <th>Biomass residues category (<i>k</i>)</th> <th>Biomass residues type</th> <th>Biomass residues source</th> <th>Biomass residues fate in the absence of the CDM project activity</th> <th>Biomass residues use in project scenario</th> <th>Biomass residues quantity (tonnes)</th> </tr> </thead> <tbody> <tr> <td>1</td> <td>Cane bagasse</td> <td>On-site production</td> <td>Power and heat generation on-site (B4)</td> <td>Power and heat cogeneration on-site</td> <td>372,674 tons/y</td> </tr> <tr> <td>2</td> <td>Cane leaves</td> <td>On-site cultivation</td> <td>Burnt in an uncontrolled manner (B3)</td> <td>Power and heat cogeneration on-site</td> <td>32,627 tons/y</td> </tr> <tr> <td>3</td> <td>Sawmill waste</td> <td>Forestry industry</td> <td>Burnt in an uncontrolled manner (B3)</td> <td>Power and heat cogeneration on-site</td> <td>19,931 tons/y</td> </tr> </tbody> </table>	Biomass residues category (<i>k</i>)	Biomass residues type	Biomass residues source	Biomass residues fate in the absence of the CDM project activity	Biomass residues use in project scenario	Biomass residues quantity (tonnes)	1	Cane bagasse	On-site production	Power and heat generation on-site (B4)	Power and heat cogeneration on-site	372,674 tons/y	2	Cane leaves	On-site cultivation	Burnt in an uncontrolled manner (B3)	Power and heat cogeneration on-site	32,627 tons/y	3	Sawmill waste	Forestry industry	Burnt in an uncontrolled manner (B3)	Power and heat cogeneration on-site	19,931 tons/y					
Biomass residues category (<i>k</i>)	Biomass residues type	Biomass residues source	Biomass residues fate in the absence of the CDM project activity	Biomass residues use in project scenario	Biomass residues quantity (tonnes)																									
1	Cane bagasse	On-site production	Power and heat generation on-site (B4)	Power and heat cogeneration on-site	372,674 tons/y																									
2	Cane leaves	On-site cultivation	Burnt in an uncontrolled manner (B3)	Power and heat cogeneration on-site	32,627 tons/y																									
3	Sawmill waste	Forestry industry	Burnt in an uncontrolled manner (B3)	Power and heat cogeneration on-site	19,931 tons/y																									
Measurement methods and procedures	Use weight meters. Adjust for the moisture content in order to determine the quantity of dry biomass. Accuracy shall comply with national or international standards.																													
Monitoring frequency	Data monitored continuously and aggregated as appropriate, to calculate emissions reductions.																													
QA/QC procedures	Calibrated as per national guidelines or supplier instructions. Crosscheck the measurements with an annual energy balance that is based on purchased quantities and stock changes																													
Purpose of data	Calculation of baseline emissions																													
Additional comments	-																													



Data / Parameter	For biomass residues categories for which scenarios B1:, B2: or B3: is deemed a plausible baseline alternative, project participants shall demonstrate that this is a realistic and credible alternative scenario
Unit	tonnes
Description	<ul style="list-style-type: none"> - Quantity of available biomass residues of type n in the region - Quantity of biomass residues of type n that are utilized (e.g. for energy generation or as feedstock) in the defined geographical region - Availability of a surplus of biomass residues type n (which cannot be sold or utilized) at the ultimate supplier to the project and a representative sample of other suppliers in the defined geographical region
Source of data	Surveys or statistics
Value(s) applied	N/A
Measurement methods and procedures	<p>Project participants may choose one among of the following procedures to demonstrate this:</p> <ul style="list-style-type: none"> ○ Demonstrate that there is an abundant surplus of the type of biomass residue in the region of the project activity which is not utilized. For this purpose, demonstrate that the quantity of that type of biomass residues available in the region is at least 25% larger than the quantity of biomass residues of that type which is utilized in the region (e.g. for energy generation or as feedstock), including the project plant demand; ○ Demonstrate for the sites from where biomass residues are sourced that the biomass residues have not been collected or utilized (e.g. as fuel, fertilizer or feedstock) but have been dumped and left to decay, land-filled or burnt without energy generation (e.g. field burning) prior to their use under the project activity. This approach is only applicable to biomass residues categories for which project participants can clearly identify the site from where the biomass residues are sourced.
Monitoring frequency	At the validation stage for biomass residues categories identified <i>ex-ante</i> , and always that new biomass residues categories are included during the crediting period
QA/QC procedures	-
Purpose of data	Calculation of baseline/leakage emissions
Additional comments	-



Data / Parameter	BR_{PJ,n,y}
Unit	tonnes on dry-basis
Description	Quantity of biomass residues of category n used in the CDM project activity in year y (tonnes on dry-basis)
Source of data	On-site measurements
Value(s) applied	425,232
Measurement methods and procedures	Use weight meters. Adjust for the moisture content in order to determine the quantity of dry biomass. Accuracy shall comply with national or international standards.
Monitoring frequency	Data monitored continuously and aggregated as appropriate, to calculate emissions reductions.
QA/QC procedures	Calibrated as per national guidelines or supplier instructions. Crosscheck the measurements with an annual energy balance that is based on harvested/purchased quantities and stock changes
Purpose of data	Calculation of baseline emissions
Additional comments	The biomass residue quantities used should be monitored separately for (a) each type of biomass residue (e.g.) and each source (e.g. produced on-site, obtained from biomass residues suppliers, obtained from a biomass residues market, obtained from an identified biomass residues producer, etc.).

Data / Parameter	BR_{B4,n,y}
Unit	tonnes on dry-basis
Description	Quantity of biomass residues of category n used in the CDM project activity in year y for which the baseline scenario is B4: (tonne on dry-basis)
Source of data	On-site measurements
Value(s) applied	372,674
Measurement methods and procedures	Use weight meters. Adjust for the moisture content in order to determine the quantity of dry biomass. Accuracy shall comply with national or international standards. The bagasse belt weigher to be installed will allow auditable records for bagasse payments between the mill and the power station. This was not the case prior to the Project implementation, where the bagasse mass was currently calculated as follows: Bagasse = Sugar Cane + Imbibition Water - Mixed Juice + Mud Recycle, all the streams on the right hand side being measured.
Monitoring frequency	Data monitored continuously and aggregated as appropriate, to calculate emissions reductions.
QA/QC procedures	Calibrated as per national guidelines or supplier instructions. Crosscheck the measurements with an annual energy balance that is based on harvested/purchased quantities and stock changes
Purpose of data	Calculation of baseline emissions
Additional comments	The procedures in Step 1.4 of methodology ACM0006 should also be followed



Data / Parameter	BR_{B1/B3,n,y}
Unit	tonnes on dry-basis
Description	Quantity of biomass residues of category n used in the CDM project activity in year y for which the baseline scenario is B1: or B3: (tonnes on dry-basis)
Source of data	On-site measurements
Value(s) applied	52,558
Measurement methods and procedures	Use weight meters. Adjust for the moisture content in order to determine the quantity of dry biomass. Accuracy shall comply with national or international standards.
Monitoring frequency	Data monitored continuously and aggregated as appropriate, to calculate emissions reductions.
QA/QC procedures	Calibrated as per national guidelines or supplier instructions. Crosscheck the measurements with an annual energy balance that is based on harvested/purchased quantities and stock changes
Purpose of data	Calculation of baseline emissions
Additional comments	-

Data / Parameter	EL_{PJ,gross,y}
Unit	MWh
Description	Gross quantity of electricity generated in all power plants which are located at the project site and included in the project boundary in year y
Source of data	On-site measurements
Value(s) applied	435,522
Measurement methods and procedures	Use calibrated electricity meters. Accuracy shall comply with national or international standards.
Monitoring frequency	Data monitored continuously and aggregated as appropriate, to calculate emissions reductions.
QA/QC procedures	Calibrated as per national guidelines or supplier instructions. The consistency of metered electricity generation should be cross-checked with receipts from electricity sales (if available) and the quantity of fuels fired (e.g. check whether the electricity generation divided by the quantity of fuels fired results in a reasonable efficiency that is comparable to previous years)
Purpose of data	Calculation of baseline emissions
Additional comments	-



Data / Parameter	$EL_{PJ,imp,y}$
Unit	MWh
Description	Project electricity imports from the grid in year y
Source of data	On-site measurements
Value(s) applied	10,531
Measurement methods and procedures	Use calibrated electricity meters. Accuracy shall comply with national or international standards.
Monitoring frequency	Data monitored continuously and aggregated as appropriate, to calculate emissions reductions.
QA/QC procedures	Calibrated as per national guidelines or supplier instructions. The consistency of metered electricity generation should be cross-checked with receipts from electricity purchases
Purpose of data	Calculation of baseline emissions
Additional comments	-

Data / Parameter	$EL_{PJ,aux,y}$
Unit	MWh
Description	Total auxiliary electricity consumption required for the operation of the power plants at the project site in year y
Source of data	On-site measurements
Value(s) applied	89,610
Measurement methods and procedures	Use calibrated electricity meters. Accuracy shall comply with national or international standards.
Monitoring frequency	Data monitored continuously and aggregated as appropriate, to calculate emissions reductions.
QA/QC procedures	Calibrated as per national guidelines or supplier instructions. The consistency of metered electricity generation should be cross-checked with receipts from electricity sales (if available) and the quantity of fuels fired (e.g. check whether the electricity generation divided by the quantity of fuels fired results in a reasonable efficiency that is comparable to previous years).
Purpose of data	Calculation of baseline emissions
Additional comments	$EG_{PJ,aux,y}$ shall include all electricity required for the operation of equipment related to the preparation, storage and transport of biomass (e.g. for mechanical treatment of the biomass, conveyor belts, driers, etc.) and electricity required for the operation of all power plants which are located at the project site and included in the project boundary (e.g. for pumps, fans, cooling towers, instrumentation and control, etc.)



Data / Parameter	NCV_{BR,n,y}
Unit	GJ/tonnes of dry matter
Description	Net calorific value of biomass residue of category n in year y
Source of data	On-site measurements
Value(s) applied	14.5
Measurement methods and procedures	Measurements shall be carried out at reputed laboratories and according to relevant national or international standards.
Monitoring frequency	Measure the NCV on dry-basis, at least every six months, taking at least three samples for each measurement.
QA/QC procedures	Check the consistency of the measurements (calibrated as per national guidelines or supplier instructions) by comparing the measurement results with measurements from previous years, relevant data sources (e.g. values in the literature, values used in the national GHG inventory) and default values by the IPCC. If the measurement results differ significantly from previous measurements or other relevant data sources, conduct additional measurements.
Purpose of data	Calculation of baseline emissions
Additional comments	Ensure that the NCV is determined on the basis of dry biomass.

Data / Parameter	Moisture content of the biomass residues
Unit	% Water content in mass basis in wet biomass residues
Description	Moisture content of each biomass residues type <i>k</i>
Source of data	On-site measurements
Value(s) applied	49.6
Measurement methods and procedures	The moisture content should be monitored for each batch of biomass of homogeneous quality. Accuracy shall comply with national or international standards.
Monitoring frequency	The weighted average should be calculated for each monitoring period and used in the calculations.
QA/QC procedures	Calibrated as per national guidelines or supplier instructions
Purpose of data	Calculation of baseline emissions
Additional comments	-



Data / Parameter	P_y
Unit	Use suitable units, as appropriate
Description	Quantity of the main product of the production process (e.g. sugar cane, rice) produced in year y from plants operated at the project site
Source of data	On-site measurements
Value(s) applied	263,118
Measurement methods and procedures	Data aggregated as appropriate
Monitoring frequency	-
QA/QC procedures	-
Purpose of data	Calculation of baseline emissions
Additional comments	-

Data / Parameter	LOC_y
Unit	hour
Description	Length of the operational campaign in year y
Source of data	On-site measurements
Value(s) applied	6,048
Measurement methods and procedures	Record and sum the hours of operation of the CDM project activity facilities during year y.
Monitoring frequency	-
QA/QC procedures	-
Purpose of data	Calculation of baseline emissions
Additional comments	-

▪ **Project emissions parameters monitored:**

Parameters to determine project emissions from transport of the biomass residues:



Data / Parameter	$D_{f,y}$
Unit	kilometre
Description	Return trip distance between the origin and destination of freight transportation activity f in year y
Source of data	Records of vehicle operator or records by project participants
Value(s) applied	200
Measurement methods and procedures	Determined once for each freight transportation activity f for a reference trip using the vehicle odometer or any other appropriate sources (e.g. on-line sources)
Monitoring frequency	To be updated whenever the distance changes.
QA/QC procedures	Check consistency of distance records provided by the truckers by comparing recorded distances with other information from other sources (e.g. maps).
Purpose of data	Calculation of project/leakage emissions
Additional comments	Applicable to Option B Conservative ex-ante average based on a maximum range of transportation of 100km each way.

Data / Parameter	$FR_{f,y}$
Unit	tonnes
Description	Total mass of freight transported n freight transportation activity f in year y
Source of data	Records by project participants or records by truck operators
Value(s) applied	93,157
Measurement methods and procedures	Using weight or volume meters. If volume meters are used convert to mass units using the density of each category of biomass residues. Accuracy shall comply with national or international standards.
Monitoring frequency	Data monitored continuously and aggregated as appropriate
QA/QC procedures	Calibrated as per national guidelines or supplier instructions. Check consistency of mass records with biomass residues categories and quantities used in the project activity
Purpose of data	Calculation of project/leakage emissions
Additional comments	Applicable to Option B



Parameters to determine project emissions from fossil fuel consumption (if any occurred):

Data / Parameter	$FC_{i,j,y}$
Unit	Mass or volume unit per year (e.g. ton/yr or m ³ /yr)
Description	Quantity of fuel type <i>i</i> combusted in process <i>j</i> during the year <i>y</i>
Source of data	Onsite measurements
Value(s) applied	-
Measurement methods and procedures	<ul style="list-style-type: none"> • Use either mass or volume meters. In cases where fuel is supplied from small daily tanks, rulers can be used to determine mass or volume of the fuel consumed, with the following conditions: The ruler gauge must be part of the daily tank and calibrated at least once a year and have a book of control for recording the measurements (on a daily basis or per shift); • Accessories such as transducers, sonar and piezoelectronic devices are accepted if they are properly calibrated with the ruler gauge and receiving a reasonable maintenance; • In case of daily tanks with pre-heaters for heavy oil, the calibration will be made with the system at typical operational conditions.
Monitoring frequency	Continuously
QA/QC procedures	<p>The consistency of metered fuel consumption quantities should be cross-checked by an annual energy balance that is based on purchased quantities and stock changes.</p> <p>Where the purchased fuel invoices can be identified specifically for the CDM project, the metered fuel consumption quantities should also be cross-checked with available purchase invoices from the financial records.</p>
Purpose of data	Calculation of project emissions
Additional comments	-

Data / Parameter	NCV _{i,y}											
Unit	GJ per mass or volume unit (e.g. GJ/m ³ , GJ/ton)											
Description	Weighted average net calorific value of fuel type <i>i</i> in year <i>y</i>											
Source of data	<p>The following data sources may be used if the relevant conditions apply:</p> <table border="1"> <thead> <tr> <th>Data source</th> <th>Conditions for using the data source</th> </tr> </thead> <tbody> <tr> <td>a) Values provided by the fuel supplier in invoices</td> <td>This is the preferred source if the carbon fraction of the fuel is not provided (Option A)</td> </tr> <tr> <td>b) Measurements by the project participants</td> <td>If a) is not available</td> </tr> <tr> <td>c) Regional or national default values</td> <td>If a) is not available These sources can only be used for liquid fuels and should be based on well documented, reliable sources (such as national energy balances)</td> </tr> <tr> <td>d) IPCC default values at the upper limit of the uncertainty at a 95% confidence interval as provided in Table 1.2 of Chapter 1 of Vol. 2 (Energy) of the 2006 IPCC Guidelines on National GHG Inventories</td> <td>If a) is not available</td> </tr> </tbody> </table>		Data source	Conditions for using the data source	a) Values provided by the fuel supplier in invoices	This is the preferred source if the carbon fraction of the fuel is not provided (Option A)	b) Measurements by the project participants	If a) is not available	c) Regional or national default values	If a) is not available These sources can only be used for liquid fuels and should be based on well documented, reliable sources (such as national energy balances)	d) IPCC default values at the upper limit of the uncertainty at a 95% confidence interval as provided in Table 1.2 of Chapter 1 of Vol. 2 (Energy) of the 2006 IPCC Guidelines on National GHG Inventories	If a) is not available
Data source	Conditions for using the data source											
a) Values provided by the fuel supplier in invoices	This is the preferred source if the carbon fraction of the fuel is not provided (Option A)											
b) Measurements by the project participants	If a) is not available											
c) Regional or national default values	If a) is not available These sources can only be used for liquid fuels and should be based on well documented, reliable sources (such as national energy balances)											
d) IPCC default values at the upper limit of the uncertainty at a 95% confidence interval as provided in Table 1.2 of Chapter 1 of Vol. 2 (Energy) of the 2006 IPCC Guidelines on National GHG Inventories	If a) is not available											
Value(s) applied	-											
Measurement methods and procedures	For a) and b): Measurements should be undertaken in line with national or international fuel standards											
Monitoring frequency	<p>For a) and b): The NCV should be obtained for each fuel delivery, from which weighted average annual values should be calculated</p> <p>For c): Review appropriateness of the values annually</p> <p>For d): Any future revision of the IPCC Guidelines should be taken into account</p>											
QA/QC procedures	Verify if the values under a), b) and c) are within the uncertainty range of the IPCC default values as provided in Table 1.2, Vol. 2 of the 2006 IPCC Guidelines. If the values fall below this range collect additional information from the testing laboratory to justify the outcome or conduct additional measurements. The laboratories in a), b) or c) should have ISO17025 accreditation or justify that they can comply with similar quality standards.											
Purpose of data	Calculation of project emissions.											
Additional comments	Applicable where Option B is used											



Data / Parameter	$EF_{CO_2,i,j}$	
Unit	tCO ₂ /GJ	
Description	Weighted average CO ₂ emission factor of fuel type <i>i</i> in year <i>y</i>	
Source of data	The following data sources may be used if the relevant conditions apply:	
	Data source	Conditions for using the data source
	a) Values provided by the fuel supplier in invoices	This is the preferred source
	b) Measurements by the project participants	If a) is not available
	c) Regional or national default values	If a) is not available These sources can only be used for liquid fuels and should be based on well documented, reliable sources (such as national energy balances)
	d) IPCC default values at the upper limit of the uncertainty at a 95% confidence interval as provided in Table 1.4 of Chapter 1 of Vol. 2 (Energy) of the 2006 IPCC Guidelines on National GHG Inventories	If a) is not available
Value(s) applied	-	
Measurement methods and procedures	For a) and b): Measurements should be undertaken in line with national or international fuel standards	
Monitoring frequency	For a) and b): The CO ₂ emission factor should be obtained for each fuel delivery, from which weighted average annual values should be calculated. For c): Review appropriateness of the values annually For d): Any future revision of the IPCC Guidelines should be taken into account	
QA/QC procedures	-	
Purpose of data	Calculation of project emissions	
Additional comments	Applicable where Option B is used For a): If the fuel supplier does provide the NCV value and the CO ₂ emission factor on the invoice and these two values are based on measurements for this specific fuel, this CO ₂ factor should be used. If another source for the CO ₂ emission factor is used or no CO ₂ emission factor is provided, Options b), c) or d) should be used.	

D.7.2. Description of the monitoring plan

The project is operated by Tongaat Hulett, which ensures the overall site management in accordance with South African Laws and technology providers' guidelines, and will perform the monitoring in-house. The project monitoring will comply with the monitoring methodology ACM0006 and the CDM Project Standard.

Therefore, all relevant parameters will be reliably monitored and cross-checked through calibrated measurement equipment as per the monitoring plan to be adopted. It will also include staff training, monitoring equipment maintenance/calibration procedures and emergency strategy.

All data collected as part of monitoring will be archived electronically and be kept at least for 2 years after the end of the last crediting period.

Monitoring organization

Prior to the start of the crediting period, the organization of the monitoring team will be established. Clear roles and responsibilities will be assigned to all staff involved in the CDM project.

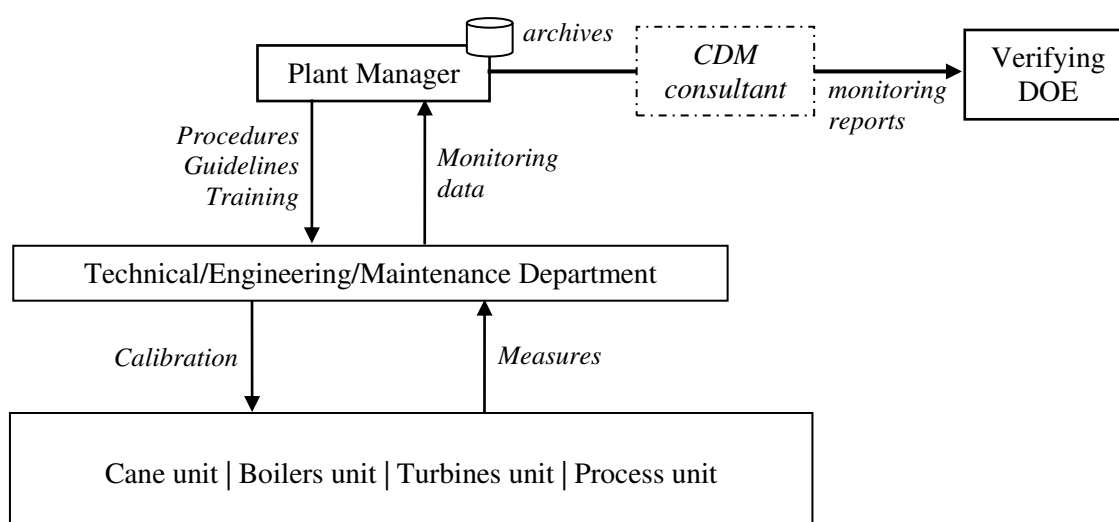

Figure 6: Monitoring organization flow diagram

The Plant Manager will coordinate and endorse the overall responsibility for all CDM monitoring of the project, including:

- Develop, approve, execute, and improve the CDM Monitoring/Reporting Procedures;
- Organize in-house seminar to inform and train the company staff to the monitoring procedures;
- Ensure that instrumentations and devices are available and properly suited to efficiently perform the monitoring;
- Communicate and coordinate the monitoring work of all business units;
- Validate and electronically archive all monitoring data on a monthly basis throughout the crediting period (and conserve it at least for 2 further years);
- Calculate and report the emission reductions; and
- Coordinate the DOE work during the verification audit.

If relevant, the Plant Manager might appoint a CDM coordinator to delegate him the above specific tasks of monitoring supervision.



The Technical/Engineering/Maintenance Department will undertake the technical actions required by the monitoring plan, under the Plant Manager's authority, to collect and record related data.

The Accounting/Sales Department will crosscheck, reconcile or consolidate data with multiple sources whenever possible. At minimum, data on combusted biomass mass and composition is to be reconciled against global collection records; data obtained from the electricity meters is to be crosschecked with the electricity invoices; and data on abnormal fossil fuel consumption is to be crosschecked with fuel supplier invoices. This kind of reconciliation activity will be recorded properly as DOE may request for such information during the verification.

Optionally, the Chief Financial Officer may find necessary to monitor the CER production closely to assess/account for the financial risks/potential revenues.

SECTION E. Approval and authorization

The letter of approval from each Party to be involved in the project activity is not available at the time of submitting the CPA-DD to the validating DOE.

**Appendix 1: Contact information on entity/individual responsible for the CPA**

Organization	Tongaat Hulett
Street/P.O. Box	Private Bag 3
Building	-
City	Glenashley
State/Region	KwaZulu-Natal
Postcode	4022
Country	South Africa
Telephone	+27 32 439 4019
Fax	+27 31 570 1055
E-mail	info@tongaat.com
Website	www.tongaat.com
Contact person	Mr Dave Meadows
Title	Executive Director
Salutation	Mr
Last name	Meadows
Middle name	Mark
First name	Dave
Department	Technology Management
Mobile	-
Direct fax	+27 83 3868342
Direct tel.	+27 32 4394311
Personal e-mail	Dave.Meadows@tongaat.com

Tongaat Hulett is not a project participant.

CDM consultant

ecosur afrique

Alexandre Dunod (CDM Project Manager)
a.dunod@ecosurafrique.com

Aurélie Lepage (COO)
a.lepage@ecosurafrique.com

ecosur afrique is not a project participant.



Appendix 2: Affirmation regarding public funding

This section is not relevant, as no public funds are involved in the CPA.



Appendix 3: Applicability of the selected methodology(ies).

No further background information on the applicability of the selected methodology(ies) is available.



Appendix 4: Further background information on ex ante calculation of emission reductions

No further background information on ex ante calculation of emission reductions is available.



Appendix 5: Further background information on monitoring plan

N/A



Table of Figures

Figure 1: <i>Amatikulu crushing history</i>	3
Figure 2: <i>Location of the CPA in South Africa (source: United Nations Cartographic Section)</i>	7
Figure 3: <i>CPA locality plan (source: Final Scoping Report)</i>	7
Figure 4: <i>Project boundary flow diagram</i>	27
Figure 5: <i>Baseline vs. Project activity simplified comparative diagram</i>	39
Figure 6: <i>Monitoring organization flow diagram</i>	74

Bibliography

1. McIntyre. (2002). *A REVIEW OF THE COMMON CAUSES OF BOILER FAILURE IN THE SUGAR INDUSTRY*. Cape Town, South Africa: Alstom Power - John Thompson Boiler Division.
2. Norris, G., & Volschenk, J. (2007). *Can sugar provide a spark?* USB Leaders' Lab.
3. South Africa DNA. (2004, October). *SD criteria for approval of CDM projects by the DNA*. Retrieved from Designated National Authority (DNA) for Clean Development Mechanism (CDM) in South Africa:
<http://www.energy.gov.za/files/esources/kyoto/Web%20info/Annex%203%20SA%20Sustainable%20Development%20Criteria.pdf>
4. Wiense. (2002). *BOILERS, BOILER FUEL AND BOILER EFFICIENCY*. Durban: Sugar Milling Research Institute.



History of the document

Version	Date	Nature of revision(s)
02.0	EB 66 13 March 2012	Revision required to ensure consistency with the "Guidelines for completing the component project activity design document form" (EB 66, Annex 16).
01	EB33, Annex42 27 July 2007	Initial adoption.
Decision Class: Regulatory Document Type: Form Business Function: Registration		