

# Model CC56 Electronic Scaling Counter



The CC56 is a battery powered scaling counter. It is capable of accepting both a DC pulse and a switch closure input.

It provides both five digit reset totalizer and a separate six digit non-reset totalizer. Optional functions are Rate of Flow display and scaled pulse output (requires both external power and an amplifier.)

### Specifications

- Power:**
- Supplied with one AA battery
  - Lithium Batteries Saver Circuitry (Change batteries without memory loss)

- Sleep Mode:**
- If counter is not receiving pulses, the counter will enter a sleep mode to conserve battery power. In this mode, the display will be blank. The counter will awaken when it receives a pulse or when the reset button is pressed.

- Unit Descriptors:**
- GAL, LIT, BLANK, QRT, PNT
  - Rate displayed in units per min only.
  - Displays Low Battery Warning, (BAT)

**Battery Life Expectancy:**

BATT SIZE	12 HRS/DAY	24 HRS/DAY
(1) AA	3.5 YEARS	2 YEARS

**LCD Display:**

- Low temperature LCD, good to -40°F (-40°C)
- Reset 5 digits, on 0.4" LCD segment; programmable decimal position for 0, 1 or 2 decimals.

**Non-Reset**

6 digits, on 0.218" LCD segment; whole units only.

**Rate**

When this function is activated, it displays on the 0.4" LCD segment.

Rate is accessed by pressing the reset button.

**Display Options:**

- **Rate:** Activated by cutting of jumper.
- **Pulse:** With addition of an amplifier and DC power source, the CC56 will provide a scaled pulse output. Pulser is driven by the non-reset totalizer and provides either 1 or 10 pulses per unit of volume(whole units only).

**Mounting Styles:**

- Panel Mount
- Wall Mount NEMA 4X Enclosure
- Meter Mount NEMA 4X Enclosure
- NEMA 7/4 (Explosion Proof)  
Class I, Division 1,  
Groups B, C & D  
Class II, Division 1,  
Groups E, F & G

**Environmental:**

- Operation Temperature: -40°F/C to 158°F (70°C)

**K-Factor:**

- Range: 1.00-9999

**Inputs:**

- Reed Switch or Hall Effect\*
- \*12-24 VDC Required
- 0-100 Hz Frequency
- 50/50 Duty Cycle

## Enclosure options

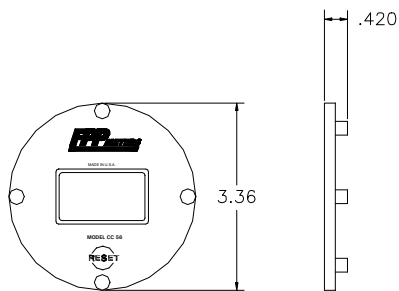

Remote mounting

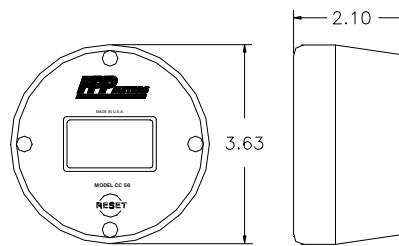

NEMA 3R Enclosure

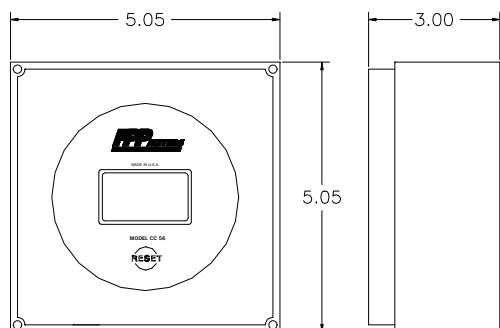

NEMA 4X Enclosure

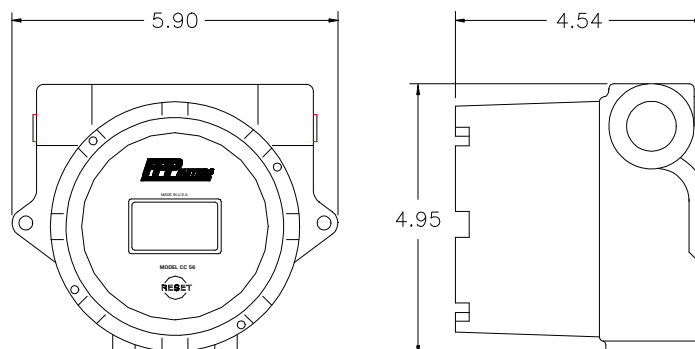

NEMA 7/4 Enclosure

## Warranty

Tuthill Transfer Systems ("Manufacturer") warrants to each buyer of its FPP Meters products (the "Buyer") for a period of 12 months from date of invoice or sales receipt, but in no event more than 18 months from date of manufacture, that goods of its manufacture ("Goods") will be free from defects of material and workmanship. Manufacturer's sole obligation under the foregoing warranties will be limited to either, at Manufacturers' option, replacing or repairing defective Goods (subject to limitations hereinafter provided) or refunding the purchase price for such Goods theretofore paid by the Buyer, and Buyer's exclusive remedy for breach of any such warranties will be enforcement of such obligations of Manufacturer. If Manufacturer so requests the return of the Goods, the Goods will be redelivered to Manufacturer in accordance with Manufacturer's instructions F.O.B. Factory. The remedies contained herein shall constitute the sole recourse of the Buyer against Manufacturer for breach of warranty. IN NO EVENT SHALL MANUFACTURER'S LIABILITY ON ANY

CLAIM FOR DAMAGES ARISING OUT OF THE MANUFACTURE SALE, DELIVERY OR USE OF THE GOODS EXCEED THE PURCHASE PRICE OF THE GOODS. The foregoing warranties will not extend to Goods subjected to misuse, neglect, accident or improper installation or maintenance, or which have been altered or repaired by anyone other than Manufacturer or its authorized representative. THE FOREGOING WARRANTIES ARE EXCLUSIVE AND IN LIEU OF ALL OTHER WARRANTIES OF MERCHANTABILITY, FITNESS FOR PURPOSE OF ANY OTHER TYPE, WHETHER EXPRESS OR IMPLIED. No person may vary the foregoing warranties and remedies except in writing signed by a duly authorized officer of Manufacturer. Warranties or remedies that differ from the foregoing shall not otherwise be binding on Manufacturer. The Buyer's acceptance of delivery of the Goods constitutes acceptance of the foregoing warranties and remedies, and all conditions and limitations thereof.



**TUTHILL**  
Transfer Systems

48513 Highway 51 North P.O. Box 400  
Tickfaw, Louisiana USA 70466  
Tel 504 542-5200 Fax 504 542-7394

www.tuthill.com

# CC56 Programming Procedure

The CC56 is a scaling counter, and can be scaled to provide a readout in almost any engineering units required by your application. The programming sequence is a time based sequence, and all data is entered using the RESET button. *(Hint: 1. When programming, the user has 5 seconds to change an icon or digit once it starts flashing. To avoid having to start over read the entire programming procedure and write out programming values for each screen before you start. 2. If the display is not visible, press RESET button before proceeding to step A.)* The programming sequence is as follows:

## A. Enter Program Mode:

Enter the programming mode by passing the program magnet over the FPP logo on the counter bezel. When the program magnet passes over the FPP logo on the bezel, the counter display will appear as in figure (A) with all segments and icons displayed. This is the indication that the CC56 is in the program mode and also allows user to check that all segments of the display are functional.

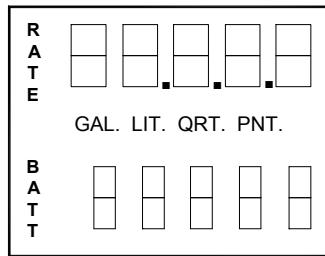

Figure (A)

## B. Review Current Program:

Press the RESET button (this advances the display to the next screen) and the counter will display both the current pulse resolution, and the current units of measure. At this point, or at any point in the programming sequence, the programming can be aborted by passing the program magnet over the FPP logo. If aborted at this step the counter will maintain the existing program. See figure (B), below.

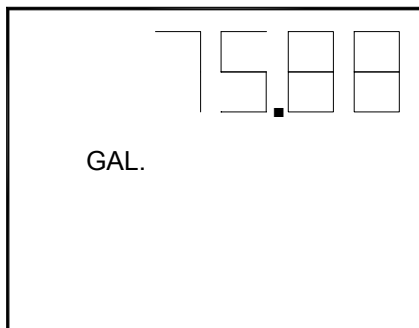

Figure (B)

*Before proceeding to program, record desired program in the form provided below.*

### CURRENT PROGRAM

UNITS OF MEASURE: \_\_\_\_\_

SCALE FACTOR D.P.: \_\_\_\_\_

SCALE FACTOR: \_\_\_\_\_

RESET TOTAL D.P.: \_\_\_\_\_

### Step 1: Select the Unit of Measure: Gallons, Liters, blank, Quarts, Pints

Depress the RESET button to advance the counter to the program screen. The display will appear as below figure (1), with the number 1 flashing in the lower left, and the current unit of measure also flashing (if no unit is displayed, the counter is programmed to the blank position, indicating a unit of measure other than that available from the standard icon selection.)

(1) Select Units of Measure: GAL, LIT, BLANK, QRT, PNT

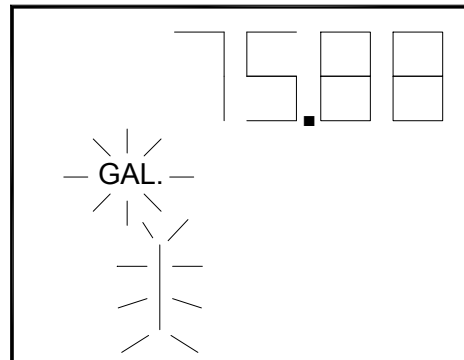

The displayed unit of measure will flash for approximately 5 seconds. To select a new unit of measure depress the RESET button and advance through the options (while the units of measure are flashing) until the desired unit is selected. The selected unit and the number 1 will continue to flash for 5 seconds. After 5 seconds, the display will stop flashing, indicating your selection has been entered. (In any program step, only the flashing portion of the screen display can be changed.)

## CC56 Programming Procedure continued...

### 2. SELECT THE SCALE FACTOR DECIMAL POINT: WHOLE, 1/10, 1/100 UNITS

Depress the RESET button to advance the counter to the next screen. The display will appear as at right figure (2) with the number 2 in the lower left, and the decimal point in the upper display flashing.

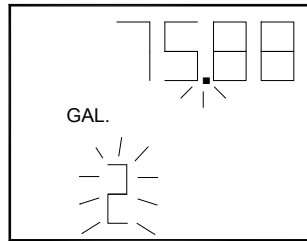

Figure (2)

Depress the RESET button to move the decimal point to the desired position for the scale factor you have selected. After approximately 5 seconds, the decimal point and the number 2 will stop flashing, indicating your selection has been entered. *Note: If no decimal is flashing, the scale factor is in whole units.*

### 3. SELECT THE SCALING FACTOR:

Depress the RESET button to advance the counter to the next screen. The display will appear as at bottom figure (3) with the number 3 in the lower left and the first digit of the current factor flashing. Depress the reset button to advance the first digit to the desired setting. After the desired setting is selected, the first digit will stop flashing after approximately 5 seconds and the second digit will begin to flash. This indicates that the first digit has been entered, and that the second digit is ready for selection. Repeat the process until the complete scale factor has been entered. Approximately 5 seconds After the last digit has been selected, the display will stop flashing, indicating the scale factor has been entered.

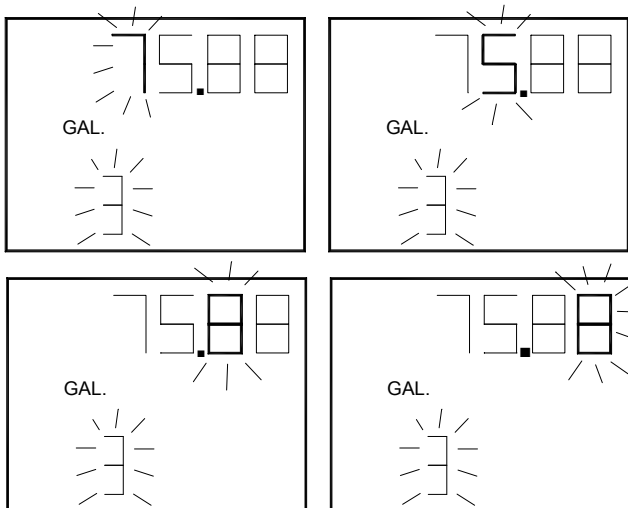

Figure (3)

### 4. SELECT THE RESET TOTAL DECIMAL POINT: WHOLE, 1/10, 1/100, 1/1000 UNITS

Depress the RESET button to advance the counter to the next screen. The display will appear as right figure (4) with the number 4 flashing in the lower left corner and Reset totalizer decimal point flashing in the current position. If the decimal is not flashing, the current location is WHOLE units and decimal is not seen.

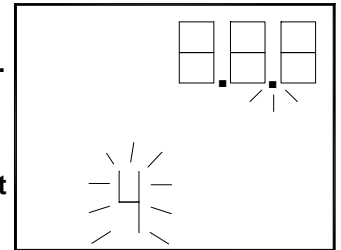
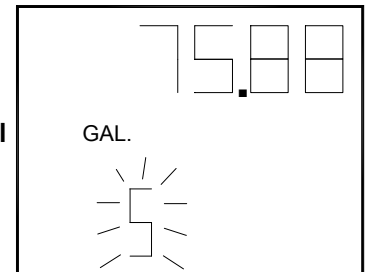

Figure (4)

Depress the RESET button to move the decimal point to the desired location. Approximately 5 seconds after the decimal location has been selected, the display will stop flashing, indicating the decimal point location has been entered.

### 5. REVIEW NEW PROGRAM:

Depress the RESET button to advance the counter to the next screen. The display will show the current scale factor, and the current units of measure, and the number 5 will be flashing in the lower left corner. See right figure (5).



### 6. PLACE THE COUNTER IN SERVICE:

Depress the RESET button to place the counter in service. The RESET TOTALIZER will display zero and the decimal point location, and the NON-RESET TOTALIZER will display the current accumulated total recalculated using the new scale factor. *Note: The Non-reset Total can only be returned to zero by removing power from the unit and allowing the battery saver circuit to discharge. This requires approximately 5 min.*

**NOTE: IF CC56 DOES NOT FUNCTION AS INDICATED, OR IF AN INVALID SCALE FACTOR HAS BEEN ENTERED, THE DISPLAY WILL INDICATE "CALC FAIL." IF THIS HAPPENS, RE-INITIALIZE BY REMOVING BATTERIES, AND SHORT CIRCUIT FROM POSITIVE TO NEGATIVE ON BATTERY HOLDER (TO REMOVE ALL ENERGY FROM UNIT.) REINSTALL BATTERIES. THIS REINITIALIZES THE PROGRAM. AFTER THIS PROCEDURE, THE CC56 DISPLAY SHOULD INDICATE "CALC" AND SHOULD FLASH, THEN UNIT IS READY FOR PROGRAM MODE. PROCEED TO STEP 1 IN PROGRAMMING.**

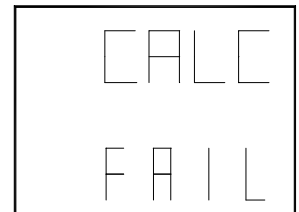

## CC56 Calibration Procedure

All FPP meters with CC56 electronic counters are programmed at the factory with the nominal K-factor (number of pulses per unit of volume through the meter) for the number of magnets or targets installed in the meter supplied with the counter. The K-factor is stamped on the meter cover along with the meter Model No. and Serial No. To improve the system accuracy, the meter should be calibrated in the system in which it is installed using the fluid to be measured.

To calibrate the meter, some standard must be used (Seraphin calibration can, weigh scale, master meter, etc.) A down stream valve is required to block the flow of product to your system, and a sample valve is required to allow a measured sample to flow into the test can or onto the weigh scale. A valve to maintain back pressure on the meter is recommended to simulate actual metering conditions. A sample piping schematic is shown below.

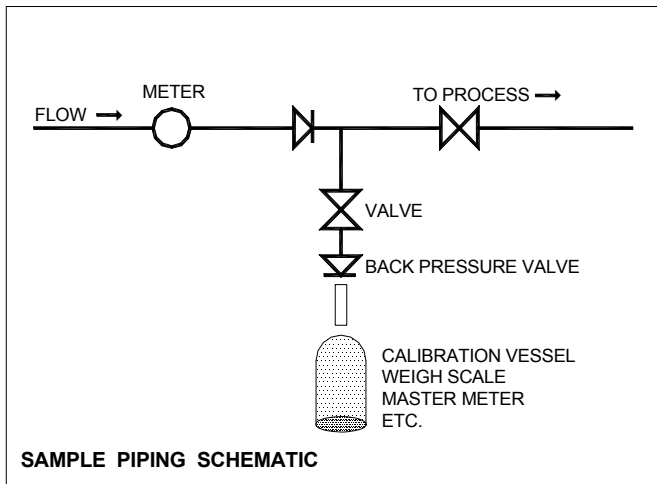

To calibrate the meter proceed as follows:

1. Record the current K-factor in the electronic register. In the case of the CC56, this can be found on the second screen after entering the Programming Sequence.
2. Reset the CC56 K-factor (FAC) to (1.0). This allows the electronic register to count and display each pulse it receives.
3. Flow through the meter a unit of volume into the calibration can, or onto the scale. Record the volume in the calibration can (or the reading on the scale,) and record the number of counts indicated on the register. (Ignore any decimals in this number.)

4. Calculate the new K-factor by dividing the the number of pulses indicated on the register by the volume in the calibration can (or weight on the scale.)

5. Steps 3 and 4 should be repeated three to five times to assure a repeatable meter and good calibration.

6. Average the K-factors determined in steps 3 and 5. This becomes the meter K-factor.

7. Using the programming instructions, enter the new K-factor into the electronic register.

### EXAMPLE

Calibration Standard: 2000 ml  
Graduated cylinder

Meter: 538.0400.CC56  
Nominal Pulse Resolution—1350 PPG

#### Test 1:

Sample Collected:  
1940 ml or  
1940 ml/3785 = 0.513 Gal.

Register Counts:  
(FAC=1) 692 pulses

Factor: 692 pulses / 0.513 Gal. = 1349 PPG

#### Test 2:

Sample Collected:  
1850 ml or  
1850 ml/3785 = 0.489 Gal.

Register Counts:  
(FAC=1) 660 pulses

Factor: 660 pulses / 0.489 Gal. = 1350 PPG

Average K-factor =  $1349 + 1350 / 2 = 1350$  PPG

**Please have the following information available when you make inquiries, order replacement parts, or schedule service:**

Your meter's serial number: \_\_\_\_\_

Your meter's model number: \_\_\_\_\_

Your full service Distributor: \_\_\_\_\_

Your full service Distributor's phone number: \_\_\_\_\_

**Warranty**

---

Tuthill Transfer Systems ("Manufacturer") warrants to each buyer of its FPP Meters products (the "Buyer") for a period of 12 months from date of invoice or sales receipt, but in no event more than 18 months from date of manufacture, that goods of its manufacture ("Goods") will be free from defects of material and workmanship. Manufacturer's sole obligation under the foregoing warranties will be limited to either, at Manufacturers' option, replacing or repairing defective Goods (subject to limitations hereinafter provided) or refunding the purchase price for such Goods theretofore paid by the Buyer, and Buyer's exclusive remedy for breach of any such warranties will be enforcement of such obligations of Manufacturer. If Manufacturer so requests the return of the Goods, the Goods will be redelivered to Manufacturer in accordance with Manufacturer's instructions F.O.B. Factory. The remedies contained herein shall constitute the sole recourse of the Buyer against Manufacturer for breach of warranty. IN NO EVENT SHALL MANUFACTURER'S LIABILITY ON ANY

CLAIM FOR DAMAGES ARISING OUT OF THE MANUFACTURE SALE, DELIVERY OR USE OF THE GOODS EXCEED THE PURCHASE PRICE OF THE GOODS. The foregoing warranties will not extend to Goods subjected to misuse, neglect, accident or improper installation or maintenance, or which have been altered or repaired by anyone other than Manufacturer or its authorized representative. THE FOREGOING WARRANTIES ARE EXCLUSIVE AND IN LIEU OF ALL OTHER WARRANTIES OF MERCHANTABILITY, FITNESS FOR PURPOSE OF ANY OTHER TYPE, WHETHER EXPRESS OR IMPLIED. No person may vary the foregoing warranties and remedies except in writing signed by a duly authorized officer of Manufacturer. Warranties or remedies that differ from the foregoing shall not otherwise be binding on Manufacturer. The Buyer's acceptance of delivery of the Goods constitutes acceptance of the foregoing warranties and remedies, and all conditions and limitations thereof.



**TUTHILL**  
Transfer Systems

www.tuthill.com

48513 Highway 51 North P.O. Box 400  
Tickfaw, Louisiana USA 70466  
Tel 504 542-5200 Fax 504 542-7394