

GB Meter Franking— History with a Future

Part 1—In the Beginning

Jack Peach describes early proposals for the machine franking of mail in the UK

Many are the pages that have been written about marks on letters sent before the advent of adhesive postage stamps. Many, many more have been those describing the stamps. But how many have you seen dealing with meter franks? Not many, I guess. Surprising, though, because the first day covers of franks from the first meter machine made in this country and approved for use were wrappers around the October 1922 edition of *Philatelic Magazine*! In this series of articles the writer endeavours to fill some gaps left in earlier writings and to bring the story into the twenty-first century.

That there have been relatively few collectors of meter franks in the past does have advantages—there is still great scope for research and discovery, and choice examples of even the early franks can be acquired without selling the family home!

From the mail which drops through letter boxes these days it must be noticeable by all that the method of paying postage by prepaid adhesive labels is reducing and has almost disappeared from business mail.

The adhesive postage stamp really is a low-tech relic in an ever more high-tech

world. Printing large pictures on paper—coating the backs with adhesive—tearing these large pictures into 240 (later 200) small pieces—buying these from the post office—sticking them on the letter to be transported and handing them back to the post office, who immediately printed another design over the top to deter re-use. Then, believe it or not, some people soaked the little pieces off the letters and stuck them into books, trying to re-make the original sheets of 240 bits!

There must be a better way. There was and is, as we shall see.

Early days

Within a few decades of the postal reforms of 1839–40 the volume of mail passing through the postal system had increased enormously, mainly from business users. Factories had become larger, as had the shops which distributed their products. The postal service was used by advertisers to increase sales and by the shops to deliver bills and receipts. The cost to businesses of using the adhesive labels became a significant overhead, to say nothing of the problem of theft by staff. As years passed, the Post Office, too, was forced by cost to consider the use of machines to cancel the labels.

In this climate the Post Office received many suggestions for alleviating the problems. The earliest (as far as the writer knows) in the Heritage Collection of the Post Office (successor to the Post Office Archives) was from a Mr J G Hester on 31 May 1880. Mr Hester had invented a machine which he was offering to the Post Office, to be sold by them to businesses and others. Interestingly, he writes that he had not patented the machine because he understood it was not necessary if only used by Government! He received no immediate reply and three weeks later wrote again, and again on 21 July.

The machine, which he called a 'Stamper' (or a 'Franker'), would be set by the Post Office for a specified number of 'franks' for which payment would be made.

Each time the machine made an impression the number would be reduced by one, until reaching zero, when the machine would come to a stop and remain so until reset by the Post Office. Hester envisaged the machines being used by 'Railway Cos, Banks, Insurance Offices, Cooperative Stores ...'

Eventually, on 13 August, a reply came, informing him 'that in the absence of a specimen of the machine you speak of it is difficult to form an accurate opinion of its merits'. As far as is known by the writer, no prototype was made and demonstrated, consequently no marks exist. After further correspondence, the Post Office concluded that: '1st, It would interfere with the uniformity and simplicity of the present system.

'2nd, The adoption of the system in question would open the door to fraud on

Fig 1 A simplified sketch of a machine by Carle Busch

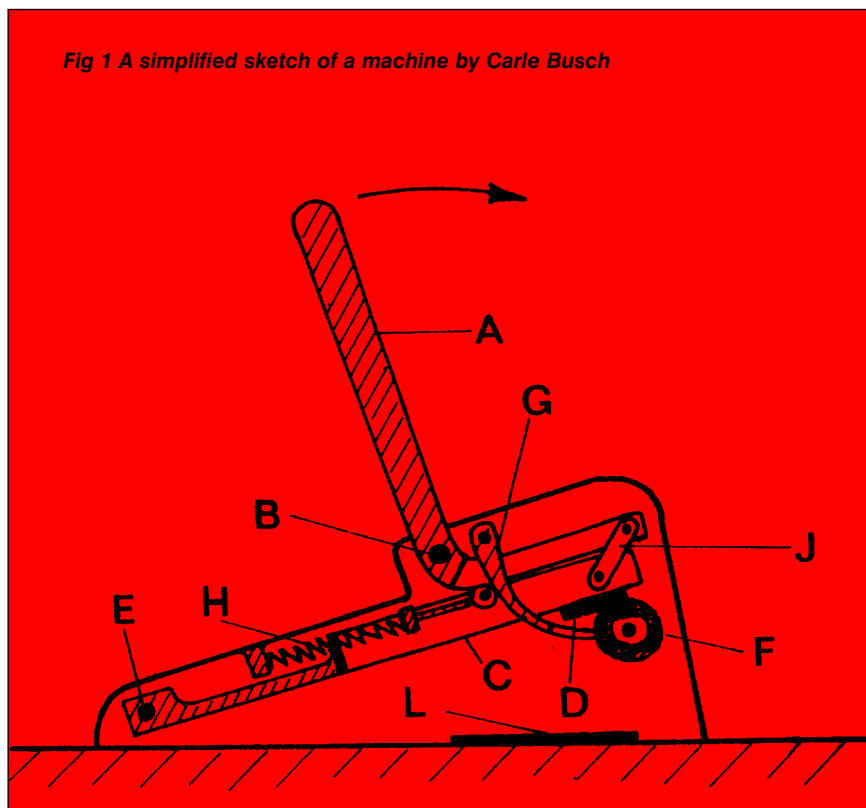

Fig 2 (right) The impression made by David Lewis's machine

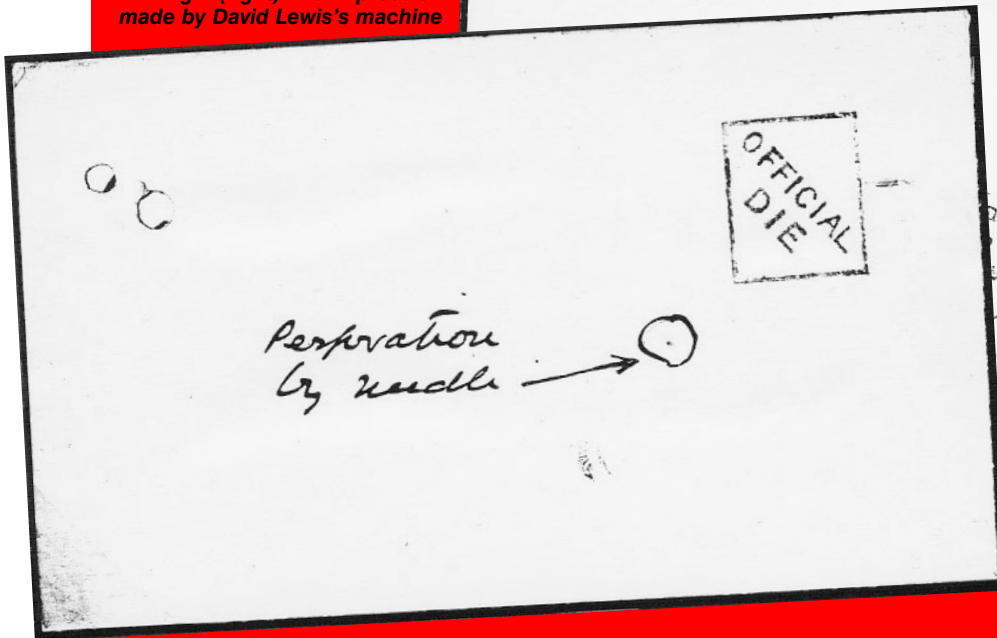
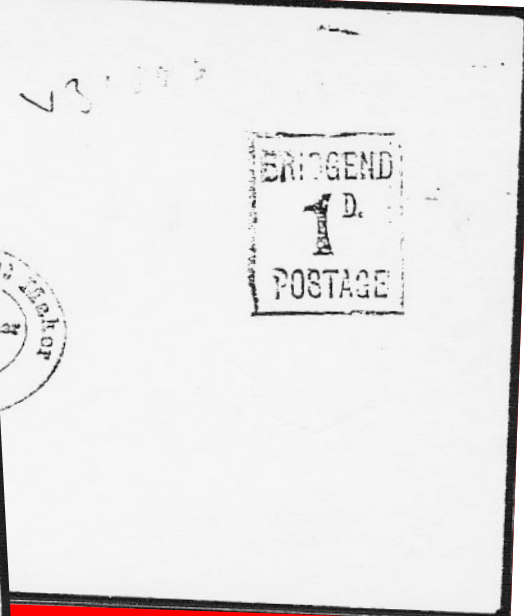

Fig 3 (left) An envelope franked by the machine of Charles Ross. The hole made by the needle is marked



the Department and that on a most extensive scale.'

During the next four decades many proposals were received with the same basic conceptions. These fell into three categories:

- a) Machines which register the number of franks printed, for which payment is made later. Not favoured by the Post Office.
- b) Machines which are set, with prepayment, to print a given number of franks then 'lock out'. Preferred by the Post Office.
- c) Machines which print an impression after a correct coin is inserted (coin-free machines).

Space will only allow brief descriptions of a few typical examples.

First patent

In 1884 Carle Busch of Paris took out a British Patent (No 11 555) for an apparatus 'for impressing and registering fiscal stamps to supersede adhesive and other moveable stamps'. The patent envisaged both postage marks and receipt or invoice marks and set out in logical order advantages to the public and to the postal and stamp departments.

Some aspects described include printing the place where the mark is applied as well as its value. A counter registered the number of marks made and when the preset number was reached the machine stopped automatically. The mark could be placed to the right or left or top or bottom of the letter or document. The apparatus was contained in a sealed case, fixed to a table or similar to prevent theft.

A very much simplified sketch of the machine is shown in Fig 1. Moving the Handle (A) forward forced the Die (D) down, past the Inking Roller (F), on to the Envelope (or Document) (L) on the base. The counter is not shown.

Interestingly, the Die shown in the Provisional Patent has place and value in French, which was changed to a Die resembling the 1d. lilac stamp of GB in the Complete Specification.

Although Mr Busch brought it to the attention of the Post Office, as far as is known it was never tested and no marks exist.

First test

It would appear that not until 1899 did any inventor bring an actual machine to the Post Office to undergo tests. That honour must go to Mr David Lewis of Bridgend, an 'Agricultural Implement & Machine Factor'. The machine worked by 'placing a Penny or halfpenny in a Slot, and the Letter or Card in another Slot, when the Penny will relieve the Stamp, and by a Sharp push on the Nob, will Stamp the Letter, and let it fall to a Suitable Receptacle.' (Quoted verbatim from the letter written by Mr Lewis on 18 October 1899.)

The machine was tested on 23 November 1899 but was rejected because the India rubber die could be readily imitated 'by the expenditure of a few coppers' and the machine itself could be actuated by plain metal discs. Fig 2 illustrates the mark made (Courtesy Heritage Collections of the Post Office).

A year later (7 December 1900) C H Kahr of Christiania (Oslo), Norway, applied for and was granted the British Patent 22 321. This was also for a coin-free machine but the coin had to be of a pre-determined weight for the machine to operate. Although installed in the lobby of Oslo GPO for public use for about three weeks, it was not tested in the UK. The Norwegian Post Office fixed adhesive stamps over the marks before transmission.

The first machine to be used by a private firm was also Norwegian. It was developed

by Karl Uchermann and made by Krag Maskinfabrik, also of Oslo. 12 machines were in use between June 1903 and January 1905, seven by the Norwegian Post Office and five by private firms. As far as is known, the machine was not tested by the Post Office or used in the UK.

Fraud prevention

On 22 November 1906 a Mr Charles Ross demonstrated to the Post Office a model of his franking machine which could be of either the coin-free or meter type. Mr Ross was told that the idea of such a machine 'was not new to the Department and that there were objections to allowing the Public to prepay correspondence in any way other than by means of Postage Stamps ...'. The model was left for testing by the Engineer in Chief who reported on 10 January 1907. Unfortunately, by the time it came to be tested it was unworkable, owing to a portion of the internal mechanism being broken—which did not augur well!

The two principal defects were:

- a. That it could be operated by a disc of metal rather than a coin.
- b. To prevent the fraud of more than one letter being franked at a time, a needle passed through the letter to be franked, holding it into position.

This was considered undesirable because it would damage contents such as photographs. Furthermore, if a sheet of metal was enclosed in the envelope the needle in the machine would be destroyed, allowing any number of letters to be franked.

Fig 3 is an illustration of a franked envelope showing the hole made by the needle. (Courtesy Heritage Collections of the Post Office).

Finally, on 31 August 1907 Mr Ross was sent a letter 'In the circumstances, the Postmaster General regrets ...'.

BRITISH STAMPS

New Zealand

A major step forward for meter franking in this country occurred on 29 September 1907 when someone in the Post Office noticed a section in the Annual Report for the year 1906–07 of the Postmaster General of New Zealand, headed 'Letter and telegram franking machine'. This recalled how in 1904 the Automatic Stamping Company Limited of Christchurch had brought a franking machine to the attention of the New Zealand Post Office. Permission had been given to the company to produce 50 machines for use between 1 January 1905 and 31 December 1910. The machines were sold or let to business firms for the prepayment of postage or telegrams. The machines contained five dies ($\frac{1}{2}$ d., 1d., 3d., 6d. and 1s.). The first machines were of the coin-freed type but later machines registered the value of franks made.

On 6 December 1907 a letter was sent from the British Post Office to the Postmaster General of New Zealand requesting further details. It concluded with a request to ask the manufacturer if they would be willing to send a machine for trial in England.

The machine in question was the invention of Ernest Moss, who had, in fact, taken out a British Patent on 3 July 1905 (No 13 660); so the Post Office staff were a little late!

At this stage it will be useful to note the advances made by the Moss machine over other contemporary designs. Referring to Fig 4, the machine was used by inserting a sovereign (£1) into Slot O which released the Handle H. The Indicator I was moved to the required value ($\frac{1}{2}$ d., 1d., 2d., 3d., 4d., 5d. or 6d., on the earliest machine, later machines normally had six values) on the Scale N. This brought the related Die D on the Quadrant Q to the stamping position (Figs 5 and 6). At the same time the Cam C, attached to the Quadrant, moved the Stop M to a position related to the value of Die D measured in units of $\frac{1}{2}$ d. To print a mark on the Letter Y the

Handle H was moved in the direction of the arrow which brought the Swinging Lever G up to the Stop M. This enabled the Pawls P to rotate the Toothed Wheel T by a number of teeth equal to the value in units of the Die. The Toothed Wheel had 240 teeth equal to the number of pennies in a sovereign. To cope with a $\frac{1}{2}$ d. ($\frac{1}{2}$ unit) Die there were two Pawls P spaced so that each could move the Toothed Wheel by half a tooth, enabling it to accommodate 480 $\frac{1}{2}$ d. units. Had there been only one pawl the wheel would have needed 480 teeth, making it too large or the teeth too tiny and subject to damage. After the Frank was printed (through an inked ribbon) the Swinging Lever returned to its 'stand by' position.

When the Toothed Wheel had rotated one revolution the coin dropped to the bottom of the box and no further marks could be made until another coin was inserted.

The sketches are very much simplified and, for instance, do not show how a small surplus amount of money remaining from the last frank impressed was debited towards the next sovereign inserted. There was also an indicator coupled to the toothed wheel which was visible through a glass window, enabling the amount franked to be checked from time to time.

What happened subsequently will be told later in this series of articles.

With multiple dies the Moss machine was a great step forward, but 15 years were to pass before a version of it was approved for use in the UK.

More tests and a public trial

In July 1909 a coin-freed machine designed by Mr E E Eyles was considered by the Post Office. In this case the actual coin inserted was used as the die to make an impression on an envelope. No trials were made by the Post Office but examples of marks were submitted by Mr Eyles and are now part of the Heritage Collections of the Post Office. By their courtesy, one of these is illustrated in Fig 7. The machine was

operated by a handle, released when a coin was inserted. Additional marks, such as place of posting, could be added to letters if desired. The machine was rejected for the usual reasons such as fraud and possible damage to letters.

On 4 July 1911 a major internal report was prepared, entitled 'Automatic Machines for franking correspondence on the coin in the slot system'. A concluding summary lists 21 reasons 'sufficiently weighty to justify the Department's consistent refusal to permit the use of such apparatus'. The last objection in the list could have been written today: 'No addition to Revenue'!

Interestingly, the Post Office did test another coin-freed machine, one which is better known to philatelists—the Wilkinson machine. Invented by F Wilkinson, it was placed for trial in the General Post Office, King Edward Street, from 25 January 1912. Fig 8 illustrates the machine (Courtesy Heritage Collections of the Post Office).

The user was faced with two slots and a handle. The letter to be franked was placed in one slot and a penny coin in the other. On turning the handle twice a 'PAID' mark was applied in red ink to the letter which was then 'gobbled up' by the machine. Fig 9 illustrates the mark.

Periodically, the letters were collected and stamped with a normal office hand-stamp to show the date and place of posting (London EC). The red mark applied by the machine was thus treated as a postage stamp.

During the three months from 25 January to 24 April, 8491 letters were franked. The daily numbers varied from 1060 on the first day to 21 on 5 April. From the middle of March the daily number was seldom more than 50. The example illustrated in Fig 9, dated 29 January, was

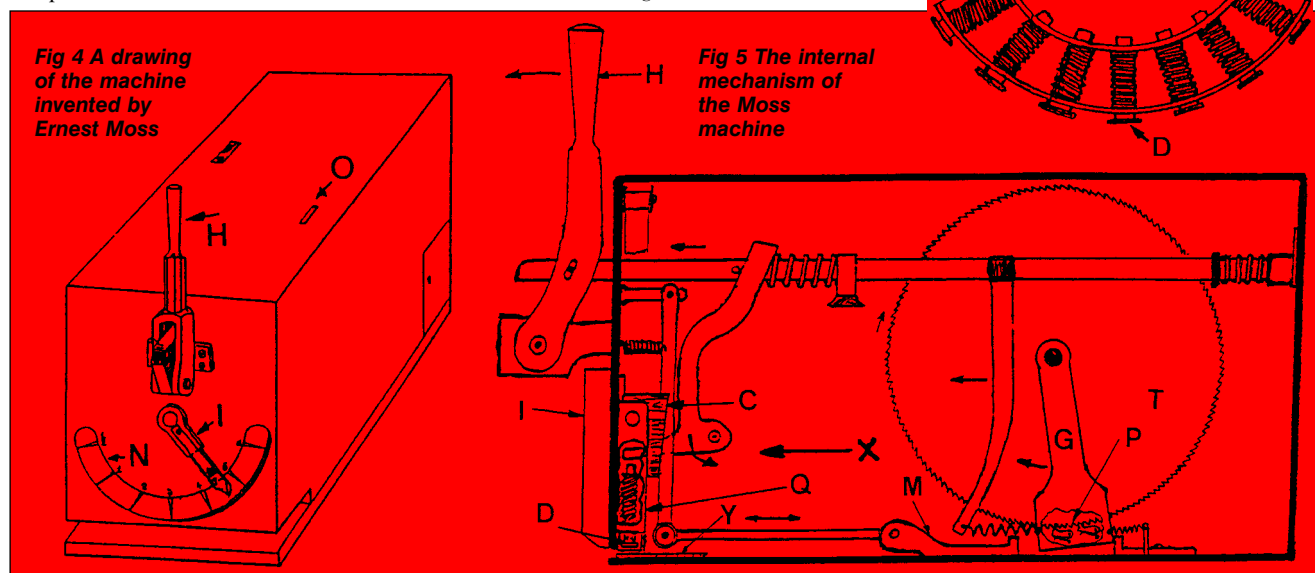

GBBOOKS

Scotland's Posts.

By James A Mackay.

Available from the author, 67 Braidpark Drive, Giffnock, Glasgow G46 6LY. Price £16, postage £3.

This book was published in November to coincide with the Glasgow 2000 exhibition and an exhibition of Glasgow post offices at the city's Mitchell Library. It provides a succinct but comprehensive survey of the origin, growth and development of all aspects of the postal services in Scotland from the early seventeenth century to the present.

The nine chapters cover The Origins of the Posts; Expansion of Services, 1745–99; Early Nineteenth Century, On the Road to Reform, 1800–39; The Early Victorian Era; Changing Roles; Early Twentieth Century; The Second World War; Immediate Post-war Period; and The Years of Change. The text relates not just to Scotland, but provides an easy-to-read account of the main postal changes affecting the whole of the UK, such as the introduction of letter boxes, the expansion of post office counter work, the effects of the world wars, and in recent times the organisational changes affecting post offices and the letter and parcel services. Indeed the final chapter, The Years of Change, is one of the most interesting in the book. Mackay writes: 'The last three decades of the twentieth century witnessed the most startling changes in every aspect of life in Scotland. Socially, economically, politically and culturally, the Scotland of today is a very different country from what it was in the 1960s.' He cites the Thatcher Years, New Labour, the rise of Scottish nationalism and devolution. On postal matters, this chapter deals with the re-organisation of the Post Office, the move of the National Savings Bank (formerly PO Savings Bank) to Glasgow, the introduction of the ubiquitous printed postage impression (PPIs), postcodes, postal changes resulting from local government reorganisation, the downgrading and regrading of post offices, the privatisation of postal services (including 1971 Strike stamps and Christmas charity posts since 1981), the demise of the inland registered service, and numerous changes in postal markings.

It is a useful and comprehensive survey of modern postal history. The book is lavishly illustrated with many hundreds of facsimiles of postmarks in the broad margins of every page, as well as maps and diagrams. The reference value of this work is enhanced by the three appendices which provide identification of the Post Office numbers of 1844–1906 (1 Aberdeen to 755 Canna), the PO numbers, 1924–69 (S1 Aberdeen to S229 Portaskaig), and the telegraphic codes of 1870–1924 (A A J Argyll Place, Aberdeen to ZYO Yorker). The three-page bibliography lists nearly 100 sources—many, not surprisingly, by the author.

Continued overleaf

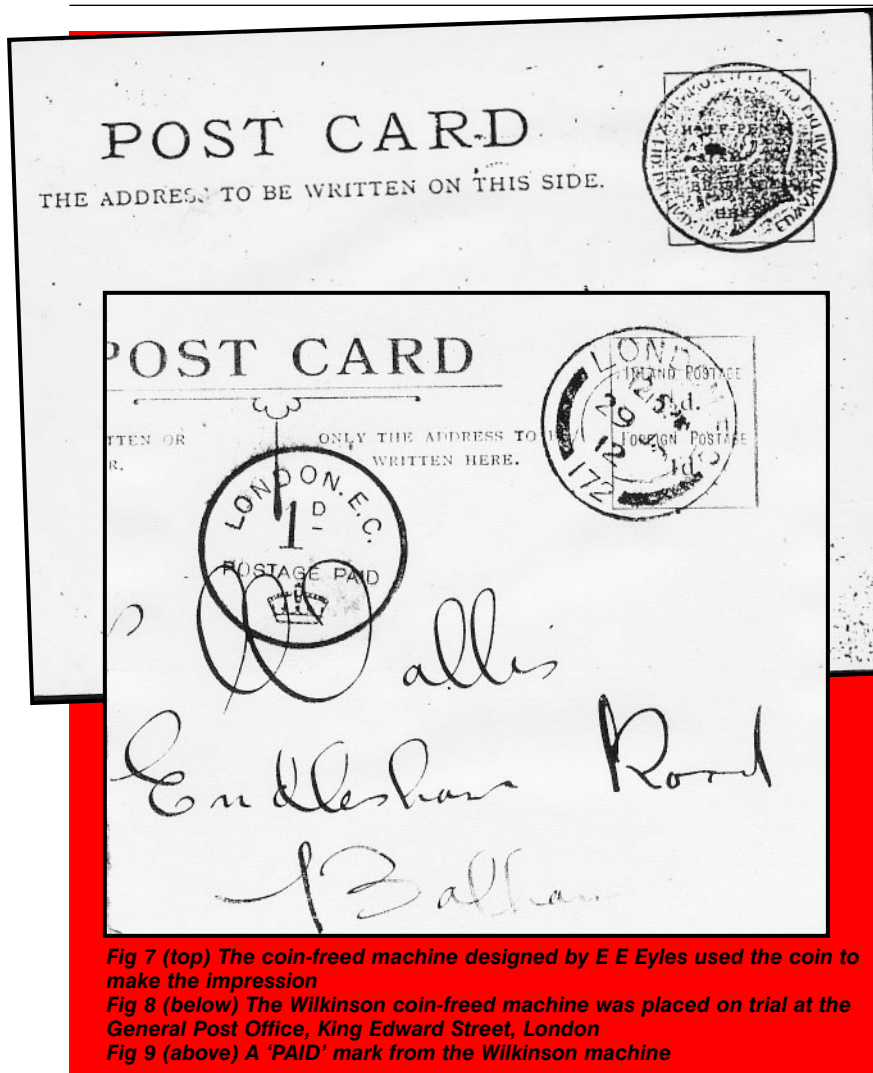

Fig 7 (top) The coin-free machine designed by E E Eyles used the coin to make the impression

Fig 8 (below) The Wilkinson coin-free machine was placed on trial at the General Post Office, King Edward Street, London

Fig 9 (above) A 'PAID' mark from the Wilkinson machine

among 375 posted that day. The trial was discontinued on 31 August 1912. No further trials were made or machines purchased, though the records show that Mr Wilkinson was still trying to sell his machine in 1927.

The *Sunday Pictorial* featured the machine on 24 April 1927 in an article headed 'Postbox that will do away with stamps!'

In the next article the further trials on the New Zealand Moss machine and the development of the American Pitney Bowes machine will be described, leading to their approval for use in 1922.

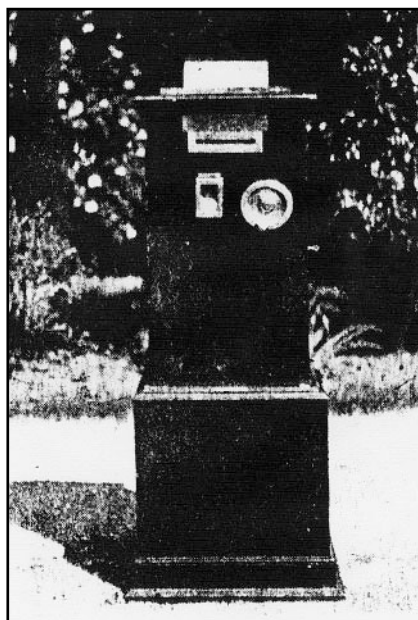

Post Office Heritage Collections

Much historical correspondence between the Post Office and machine suppliers, together with many unique franking marks are held in the Heritage Collections of the Post Office.

There is still great scope for research and interested readers who would like to view items should make an appointment by contacting:

Curator, Philately
Heritage Services
Freeling House
Phoenix Place
London WC1X 0DL