



OWNER'S MANUAL

DROP POCKET POOL TABLE

MODEL NO . P1291W

1. READ THIS MANUAL CAREFULLY BEFORE STARTING ASSEMBLY.
Read each step completely before beginning each step.
2. SOME SMALLER PARTS MAY BE SHIPPED INSIDE LARGER PARTS. CHECK INSIDE ALL PARTS AND CARTONS BEFORE ASSEMBLING OR ORDERING PARTS.
3. USE THE HARDWARE IDENTIFIER TO IDENTIFY AND USE ALL FASTENERS CHECK ALL CARTONS FOR KITS ALL HARD WARE IS LOCATED IN ONE KIT

THIS TABLE IS CONTAINED IN TWO SEPARATE CONTAINERS

PLEASE DO NOT RETURN PRODUCT TO THE STORE!

Contact Escalade® Sports customer service department at:

Phone: 1-866-556-2757 Toll Free!

Fax: 1-866-873-3532 Toll Free!

E-mail: billiardtables@escaladesports.com

Mailing Address: Escalade® Sports, PO Box 889, Evansville, IN 47706

Please visit our World Wide Web site at:

www.escaladesports.com

On-Line Trouble Shooting Frequently Asked Questions

Technical Assistance On-Line Parts Requests

Additional EscaladeSports Product Information

ESCALADE
SPORTS

Escalade® Sports products may be manufactured and/or licensed under the following patents: D446275
Additional patents may be pending. One or more of the listed patents and/or pending patents may cover specific product.

2L-7080-00

2007 Escalade Sports



CAUTION



THE SPRAY ADHESIVE USED FOR APPLYING PLAYFIELD CLOTH IS EXTREMELY FLAMMABLE AND UNDER PRESSURE! CAREFULLY READ CAUTIONS ON SPRAY ADHESIVE CONTAINER! KEEP OUT OF THE REACH OF CHILDREN! DO NOT USE OR STORE NEAR HEAT SOURCE, FLAMES, SPARKS OR WHEN SMOKING! WORK AREA MUST BE WELL VENTILATED. OPEN DOORS AND WINDOWS WHEN USING SPRAY ADHESIVE.

To ensure safety, do not attempt to assemble system without following instructions carefully. Proper and complete assembly, use, and supervision is essential for proper operation and to reduce the risk of accident or injury. A high probability of serious injury exists if this system is not installed, maintained, and operate properly.

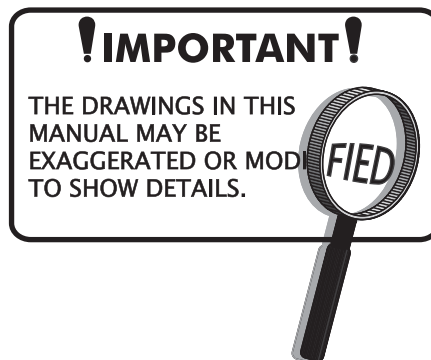

Tools Needed: (Not Included)

Standard Screwdriver
Phillips Screwdriver
Putty Knife
Sandpaper (80 grit)
Drill with 1/8" and 3/16" Drill Bit

Tape Measure
Sanding Block
Scissors or Sharp Knife

9/16" Open End Wrench
Hammer (Small Ball Peen Type)
Carpenters Level or 36" Straight Edge
Ratchet with 1/2" socket

Note: Rails are made with cushion rubber at a height that requires standard 2 1/4" diameter balls. Your dealer has a complete line of Billiard Accessories.

Note: This table adds weight to any floor. Be sure floor can withstand this kind of weight. If floor sags, table will be impossible to level.

1. Begin by opening all boxes and sort parts. Slide the eight Dove Blocks # 3 into the slots in the End Cabinet Panels # 1 and the Side Cabinet Panels # 2 (See Figure 1).

IMPORTANT! Do Not drive Dove Blocks into grooves with a hammer. If a block is too tight, try it in a different groove.

Figure 1

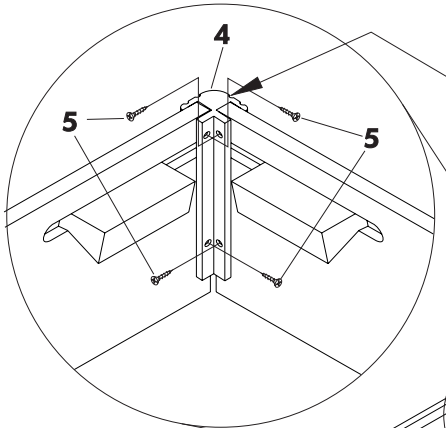
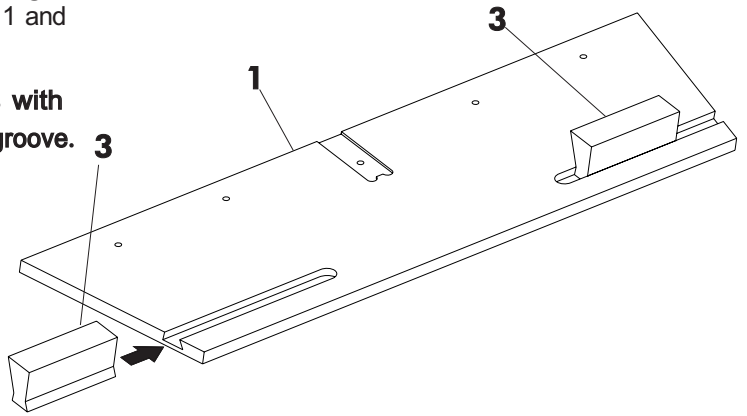

Bottom of Corner Post should be flush with bottom of Cabinet Panels

2. Attach End Cabinet Panels #1 and Side Cabinet Panels #2 with Corner Posts #4, as shown in Figure 2, using four screws #5 for each Corner Posts. **Note: Bottom of Corner Posts should be flush with bottom of Cabinet Panels.**

Figure 2

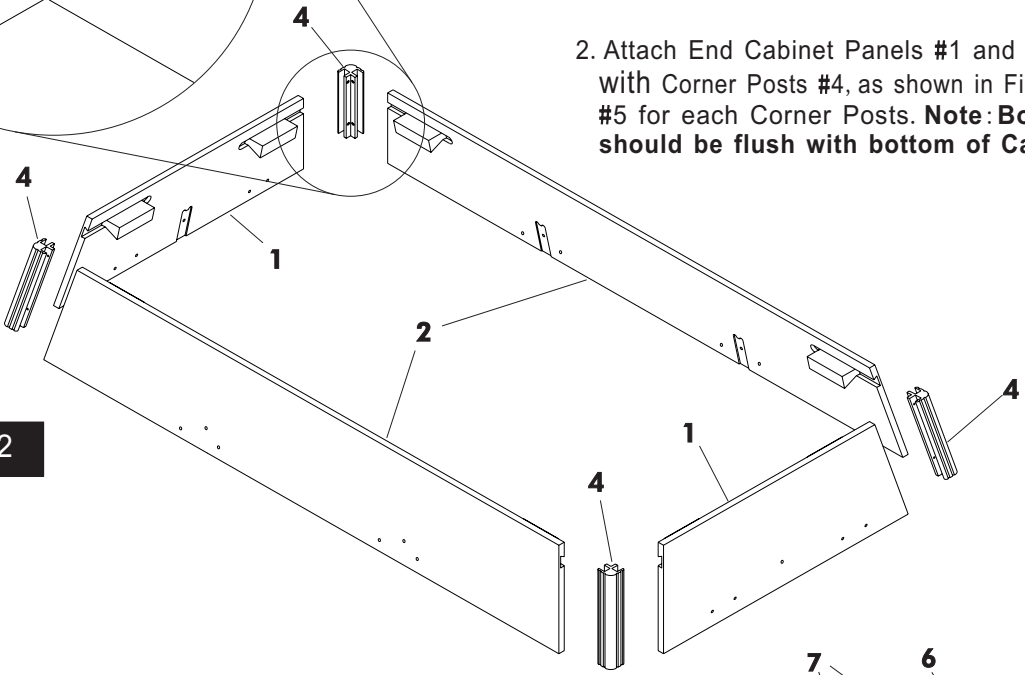

3. Set a Leg Block #6 in the corner of cabinet assembly on top of Dove Blocks #3. See Figure 3. Attach Leg Block #6 to side Cabinet Panel #2 and End Cabinet Panel #1 using two screws #7
4. Attach Leg Block #6 to Dove Blocks #3 using four screws #7. See Figure 3.
5. Repeat steps 3 and 4 for other three Leg Blocks #6.

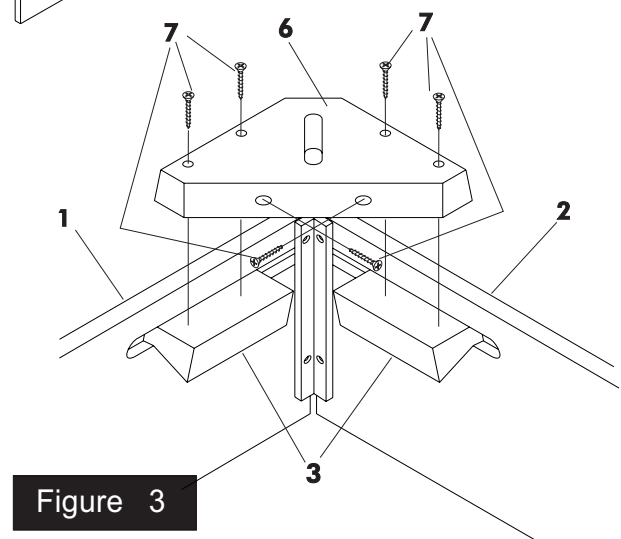

Figure 3

6. Thread a stud #9 halfway into each Leg #8
7. Attach legs #8 to Leg Blocks #6 using the stud #9 in Leg, one washer #10 and one nut #11 for each leg. Square leg up with corner of cabinet and tighten. **Remark: Pay attention to the angle of legs when assemble it. See Figure 4.**
8. With the help of another adult, flip table over onto legs.
9. Slide Center Beam #12 into slot in End Cabinet Panels #1, as shown in figure 5, and secure each end with one screw #14, one washer #15 and one dowel connector #16. Beams should be flush with top of Cabinet Panels.
10. Slide Cross Beams #13 into slots in Side Cabinet Panels #2, as shown in Figure 5, and one dowel connector #16. Beams should be flush with top of Cabinet Panels.
11. Secure two Screw Blocks #17 opposite one another in the corner of the Center Beam #12 and Cross Beam #13, as shown in Figure 6, using four screws #7 for each Screw Block.
12. Repeat step 11 for other Cross Beam #13.
13. Using screws #14 and washers #15 attach 8 pcs #43 level brace on outside of side and end panels as per FIGURE 5 .

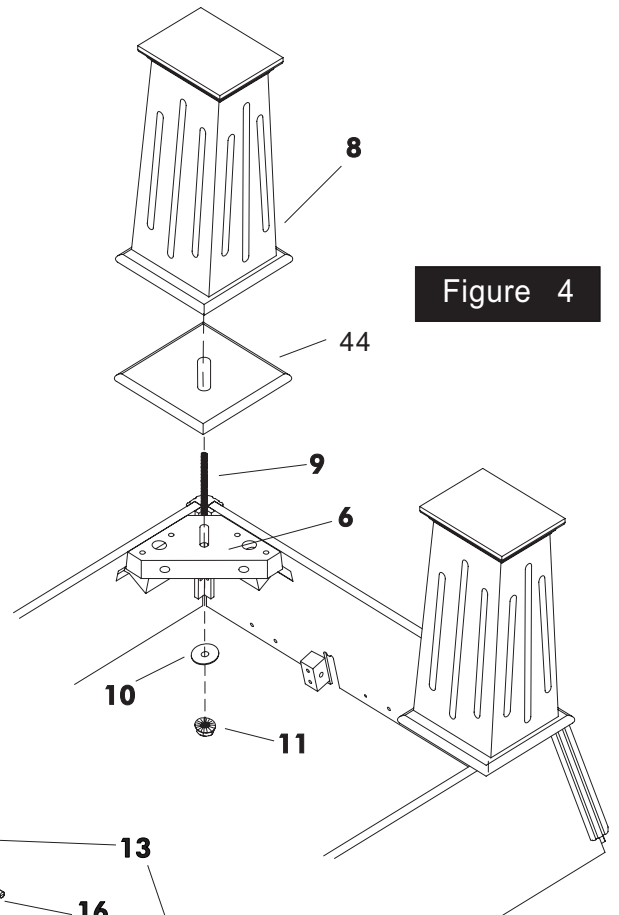

Figure 4

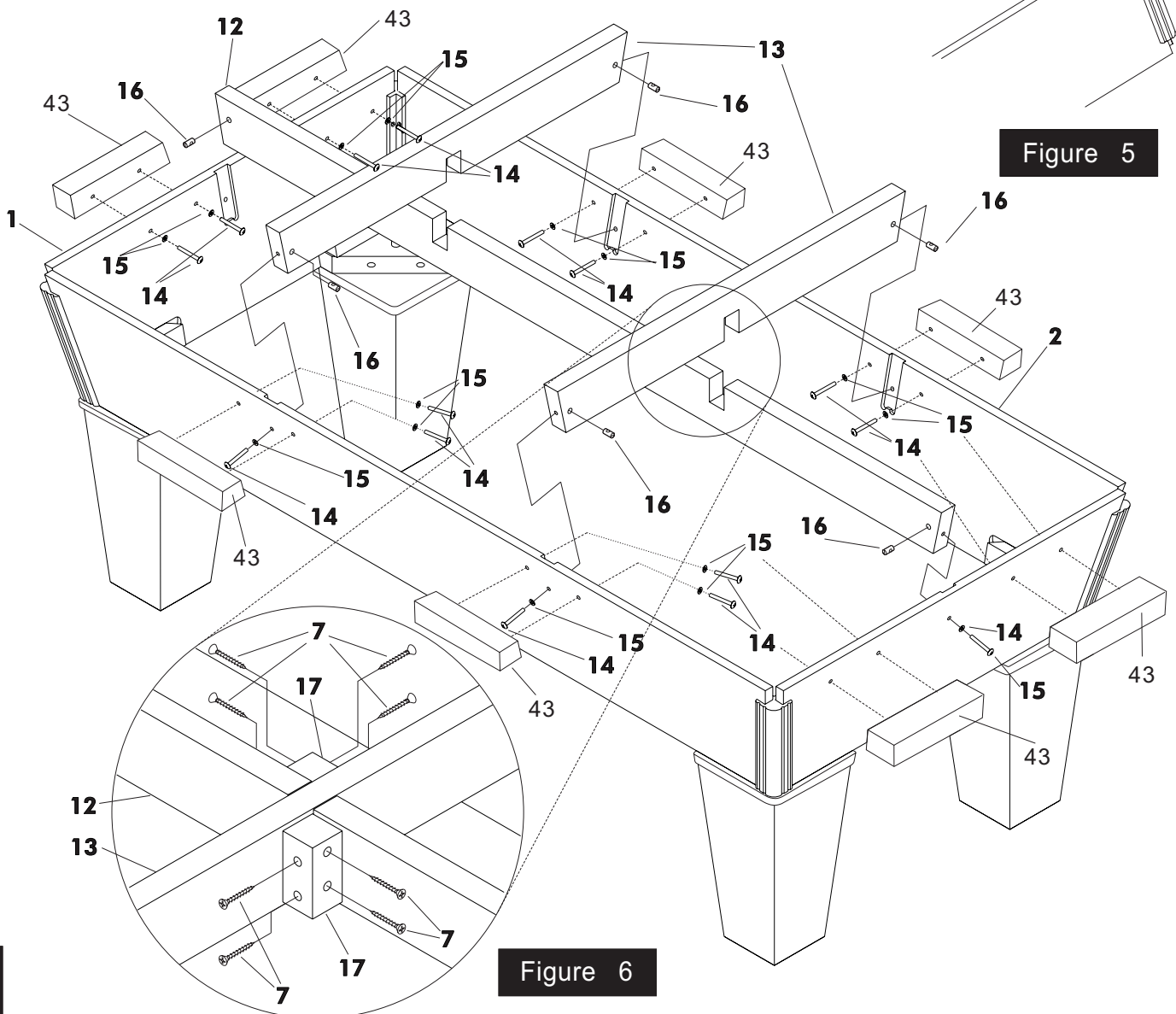

Figure 5

Figure 6

LEVELING BASE FRAME

Use a carpenter's level to level table as close as possible. It is easier to do it now rather than after the playfield has been attached to the frame.

14. Determine the highest corner of the frame by placing the level in two ways shown in Figure 8.
15. Once you have determined the highest corner. Raise other three corners to the level of the highest corner by shimming underneath legs using playing card stock or grey leg shim stock (#39) shipped with this table. Cut this shim stock and place under legs (#8).

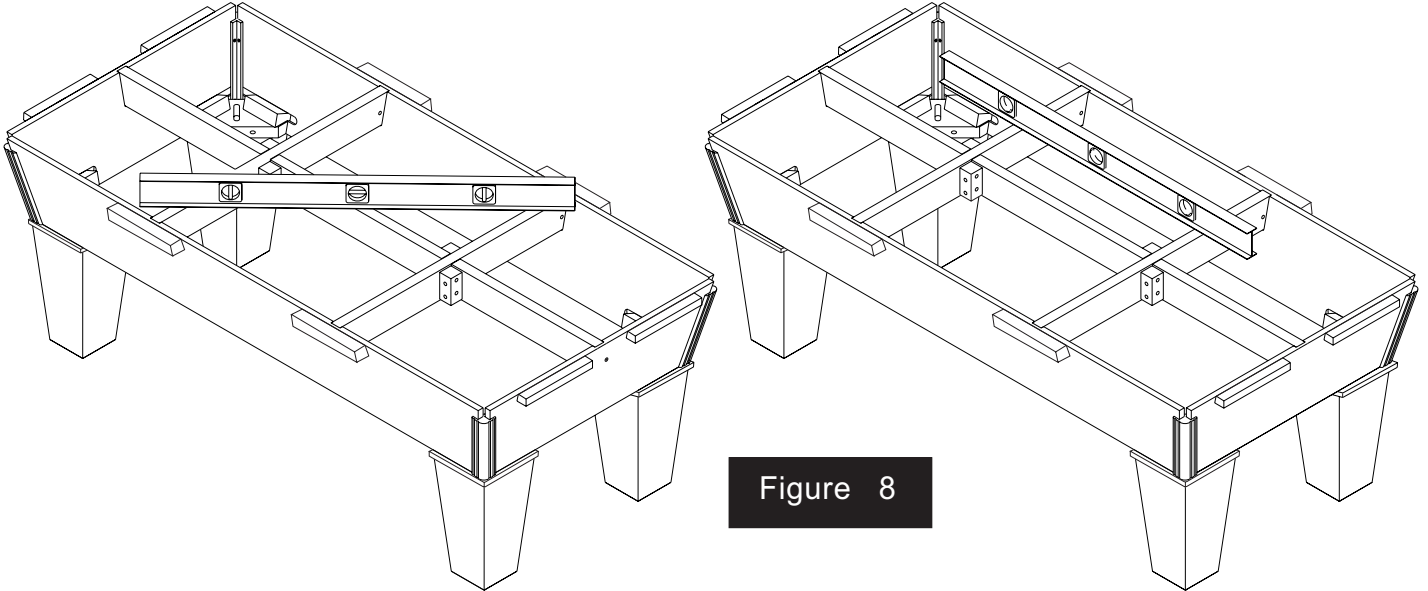

UNBOXING THE SLATE

CAUTION!

AFTER CRATE PARTS ARE REMOVED, BEND NAILS OR STAPLES OVER WITH A HAMMER AT ONCE! USE CAUTION WHEN HANDLING CRATE PARTS!

16. It is now time to uncrate the slate pieces. With a claw hammer or crow bar, pry off crate top at the notched corner. (See Figure 7) **BE CAREFUL NOT TO DAMAGE SLATE INSIDE! SLATE IS BRITTLE AND CAN BE EASILY DAMAGED IF HIT OR PRIED AGAINST!**
17. Remove the front rail of the crate. Slide the slate out the front of the crate. (Figure 8)

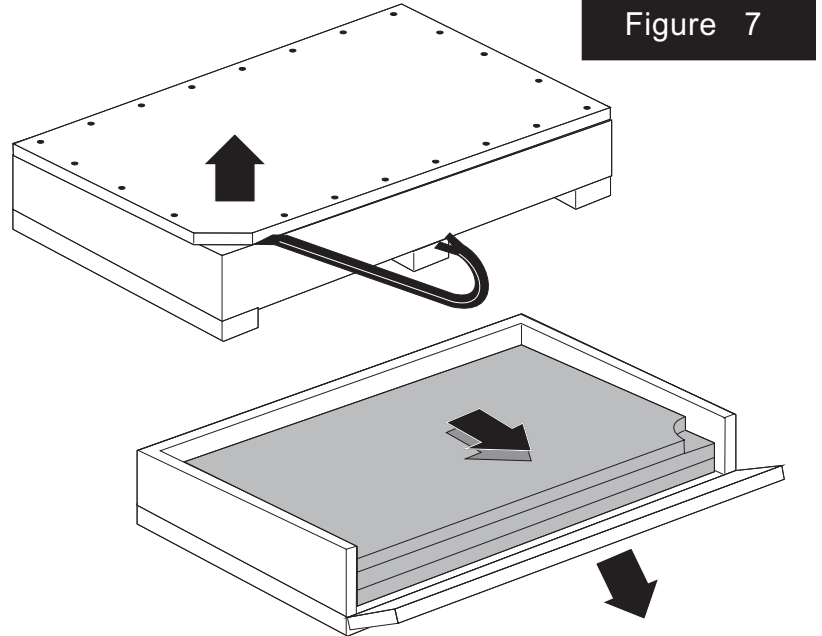

UNBOXING THE SLATRON

18. It is now time to unbox the slatron pieces. **BE CAREFUL NOT TO DAMAGE SLATRON INSIDE! SLATRON CAN BE EASILY DAMAGED IF HIT OR PRIED AGAINST!** (See Figure 9)

If the edges of your Slatron has "fuzz" on it, lightly sand to remove with sandpaper provided.

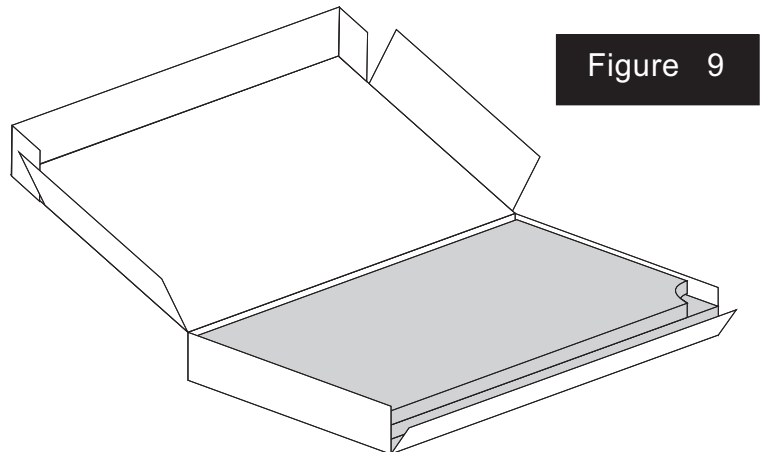

CAUTION!

The sheets of slatron may not be completely flat when removed from the shipping carton. This is normal. Once they have been placed on the table frame and securely fastened down, they will become straight and flat.

THE FOLLOWING STEP REQUIRES THE HELP OF ANOTHER ADULT!

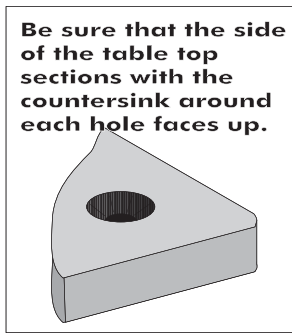

Detail A

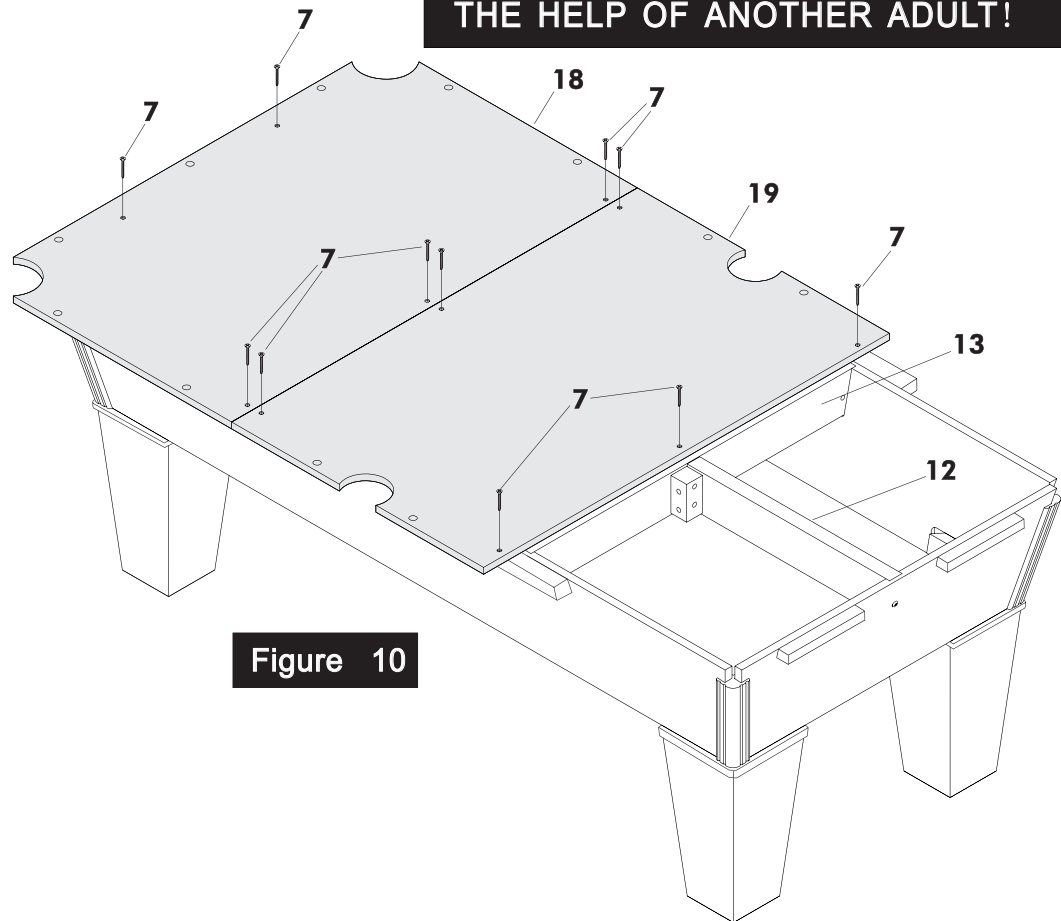

Figure 10

CAUTION: Be sure countersunk holes in all three table top sections #18 and #19 face up: See Detail "A", Figure 10.

19. Place center section #19 on the two cross beam #13. Use a tape measure to center the playfield section on table; do this by measuring the amount the playfield overhang on each side of the table. Make sure the overhang is equal of both side of the table. Next use the tape measure to make sure the playfield section is center between the two cross beam #13; do this by measuring the distance between the cross beam #13 and the edges of the playfield section. The distance should be equal on both side.
20. Using six holes in slate/slatron as a guide, drill pilot holes in Cross Beams using a 1/8" drill bit. Secure center section #19 to Cross Beams #13 with six screws #7. **NOTE: Be sure there are no gaps between center section #19 and cross beam #13. If gaps exist, tighten screws more. However do not tighten screws so much that center section begins to crush or crack.**
21. Place end sections #18 onto the table. Be sure they are square, in line and butted up tight against center section #19.

22. Using four holes in slate/slatron as a guide, drill pilot holes in Cross Beams and Center Beam using a 1/8" drill bit. Secure end sections #18 using screws #7 (four screws per end section). **NOTE: Be sure there are no gaps between end sections #18 and table. Run your finger across the two seams between center section #19 and end sections #18 to check for any uneven areas. Sections should be even.**

You should not need shims to even up the table top sections #18 and #19, so if the sections do not align, first try loosening screws and brush out underneath to remove chips etc. Then check under table to make sure there are no gaps between the table top sections and the slats. If gaps exist, tighten screws more. However, do not tighten screws so much that the sections begin to crush or crack. Top edges of seams must be precisely level and even with one another. If you need to use shims, read the shimming instructions on the following page.

SHIMMING INSTRUCTIONS

General Rules

- n Accomplish the leveling of slate/slatron with as few shims as possible.
- n Do not tap with a hammer or tighten screws unreasonable tight. You will not be able to compress the slate/slatron. You must shim up the slate/slatron to level. Shims #37 are meant only to raise the low places at the seams and ends. Very short and low places should be grouted. Do not assume the floor is level. Most leveling can be accomplished by working with the frame.
- n If power tools are used, be sure only enough torque is used to do the job.
- n Seams can best be checked by passing your finger over the seam joint and feeling if it is flush.
- n All screws must be tightened after shimming.
- n No two sets of slate/slatron are exactly alike. Some sets require more, or less, shimming than others.

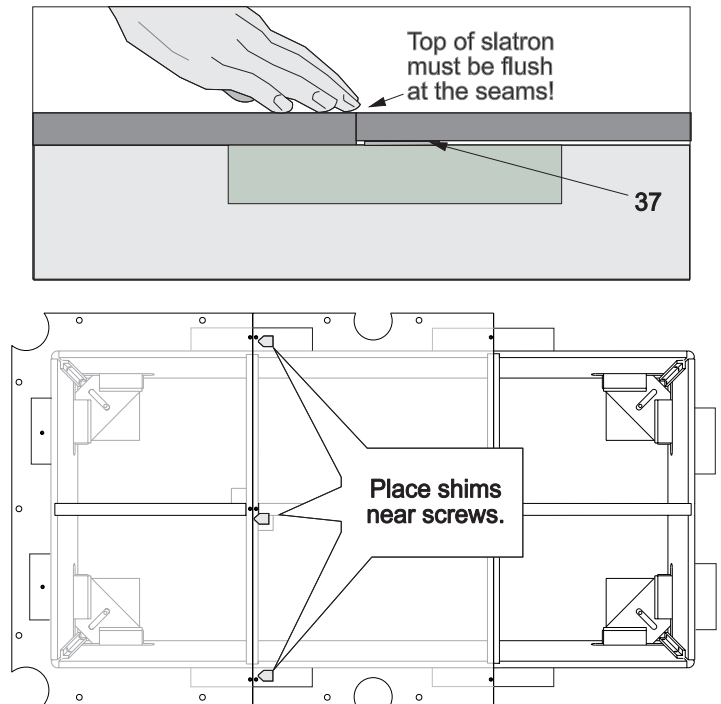

Figure 11

23. STEP BY STEP SHIMMING PROCEDURE

- A) Be sure table is set in its final location.
- B) Table must be as level as possible before shimming. Large differences in levelness must be corrected by raising or lowering frame with shim stock.
DO NOT ASSUME FLOOR IS LEVEL!
- C) Tighten down all slate/slatron mounting screws.
- D) Check with a carpenter's level to determine where slate/slatron is low on ends, and use finger tips to locate uneven spots at the seams. Loosen screws at these points and see if slate/slatron comes up to flush. If so, detach individual shims #37 from the sheet shipped with this table and place under these areas. **Place shims next to screws. (See Figure 11)**
- E) Lay a straight edge across seams to be sure slate/slatron pieces are flat **in relation to each other.**
- F) After top surface of slate/slatron is flat and level, all screws must be snugged down in tight position. **DO NOT OVERTIGHTEN SCREWS!** Check these screws before beginning grouting.

GROUTING INSTRUCTIONS

- 24. Clean top of slate/slatron with a damp cloth. **DO NOT USE TOO MUCH WATER!**
- 25. Prepare Plaster of Paris, furnished with this table. Add water sparingly. Do not mix all the powder at first; save some in case you need to thicken your initial mixture. To mix: Empty 1/3 to 1/2 of grout into container, slowly add drops of water while stirring. Grout should be a thick paste when mixed that will not drip off putty knife. If you do get grout to thin, slowly add more powder.
- 26. Using a putty knife, fill both seams and the four countersunk holes in the center playfield area. (Only the four countersunk holes in the center of the table need to be filled since the other holes will be covered by the rails.) Do not use more plaster than you need.
- 27. Let plaster dry. Read the rest of this manual while you wait!
- 28. Using a medium grit sandpaper and a sanding block, sand the plastered areas smooth and flat. **RECHECK THESE AREAS TO MAKE SURE THEY ARE FLAT.** Re-plaster if you still find low places at countersunk holes or seams.



WARNING

DO NOT SMOKE WHILE WORKING WITH CONTACT CEMENT! READ LABEL ON CEMENT CONTAINER CAREFULLY!

APPLYING THE CLOTH

29. Make sure slate/slatron is dry and free of dust.

NOTE: Before spraying adhesive, cut a portion of the shipping carton to use as a shield to prevent cement overspray.

30. Place cloth over slate/slatron with equal overhang on all sides. **NOTE: Cloth may seem small but it will stretch a great deal.**

31. Fold cloth away from end to expose slate/slatron for your first glue application. Apply contact cement to top surface in a band 4 inches wide on this end. (See Figure 12) Coat edge also. Spray cement smoothly and evenly. Allow cement to become tacky, wait at least

32. Fold cloth back over the table. With firm even pressure, press cloth onto the area that has been coated with cement. Smooth cloth down

33. Fold cloth away from side to expose slate/slatron for your second glue application. (See Figure 13). Apply cement to the side in the same manner as your first glue application. Allow cement to become tacky, wait at least one minute.

34. Fold cloth back over the table. With firm even pressure, press cloth onto the area that has been coated with cement. Smooth cloth down and over edges.

35. Fold cloth away from other side to expose slate/slatron for your third glue application. (See Figure 14). Apply cement to this side in the same manner. Allow cement to become tacky, wait at least one minute.

36. Stretch the cloth across the width and over the edge of the table. **STRETCH HARD ENOUGH TO TAKE OUT WRINKLES, BUT NOT SO HARD THAT THE CLOTH SLIPS.**

37. Fold cloth away from other end to expose slate/slatron for your fourth glue application. (See Figure 15) Apply cement to this end in the same manner. Allow cement to become tacky, wait at least one minute.

38. Make a final stretch along the length of and over the edge of the table, stretch hard enough to work out all wrinkles. (See Figure 17). If cloth is not smooth, lift and re-apply. **NOTE:** Rubbing fingers lightly across cloth should not make cloth move.

39. Locate center of pocket opening. (See Detail A and B) Using sharp scissors, make a straight cut. Next, cut to pocket edge to form pie shapes begin to relax to allow for placement. You may need to make additional cuts.

40. Spray adhesive on the underneath side of the slate/slatron around pocket face to adhere the cloth. Make sure not to get overspray of glue on table. Allow cement to become tacky, wait at least one minute. Stretch the pie shapes down and under the pocket opening. Press the cloth against the cement on the underside of the slate/slatron. Be sure entire pie shape is fully attached to underneath side of table.

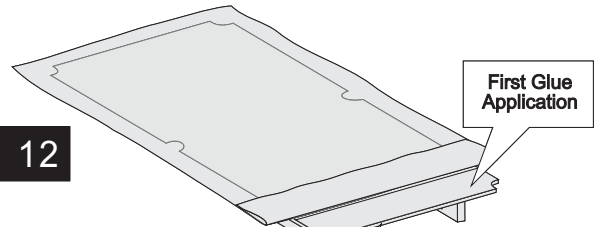

Figure 12

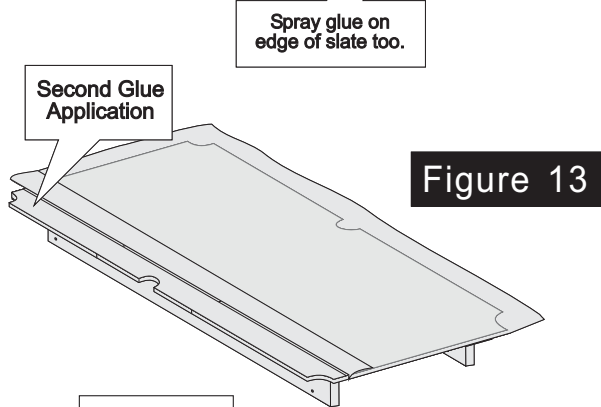

Figure 13

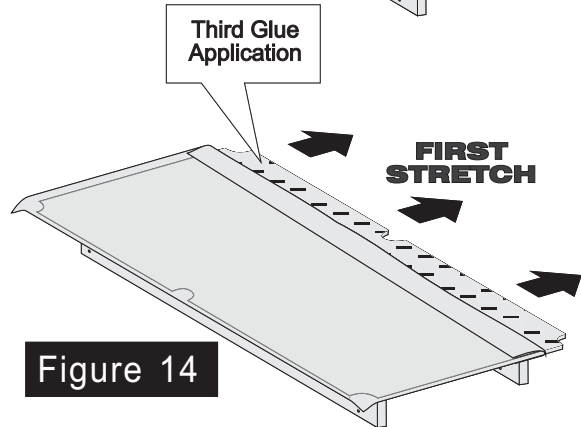

Figure 14

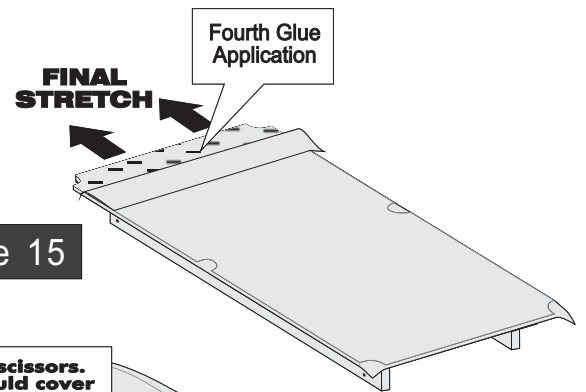

Figure 15

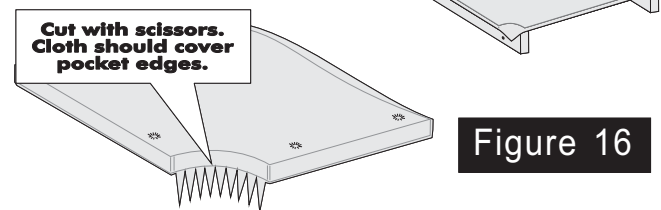
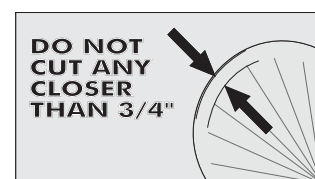
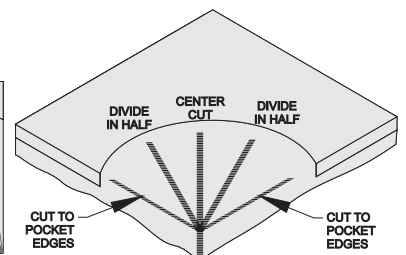

Figure 16



Detail A



Detail B

IMPORTANT! The screws #5 must be used to attach aprons.

41. Attach side aprons #24(40-7/16") to side rails #21(40-7/16") and #22(40-7/16") using three apron brackets #26 and twelve short screws #5, as shown in Figure 17.
42. Attach end aprons #25(42") to end rails #23(42") using three apron brackets #26 and twelve short screws #5, as shown in Figure 18.

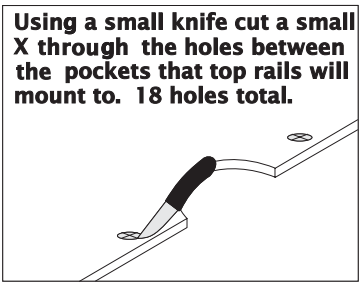

Detail A

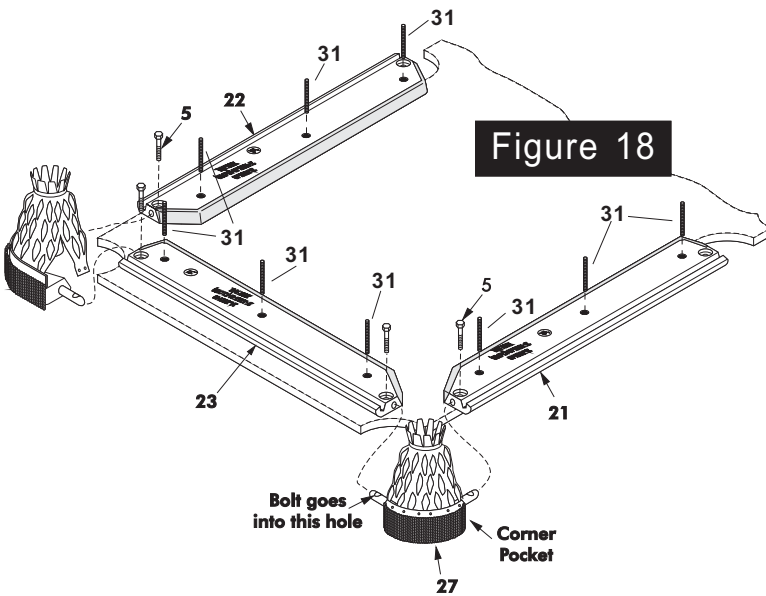

Figure 18

45. With the aid of another adult **CAREFULLY** turn the rail assemblies over. Align each assembly on the table's playfield with an equal amount of overhang around the table.
46. Find two side pockets #27, and four bolts #28. Connect the rail assemblies to the side pockets. See Figure 19. Snug rails against pocket edges before tightening bolts #28.

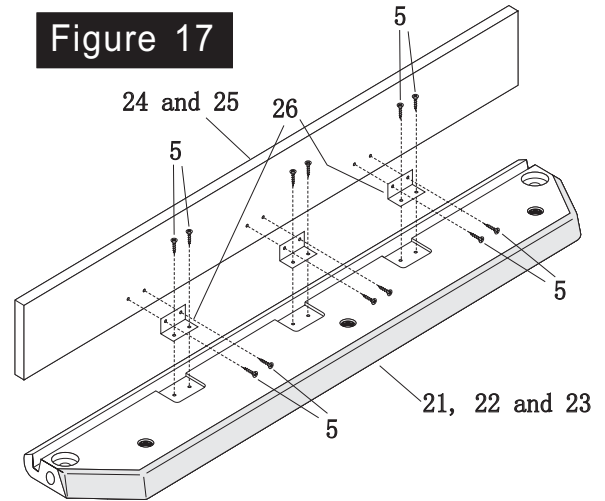

Figure 17

Assembling Rails to the Pockets

43. Find the 3/4 inch holes in the playing surface that are between each pocket and cut a small cross in the cloth over each hole for bolts to pass through. There are eighteen holes total. See Detail A.
44. Carefully turn an end rail #23, left hand rail #21 and right hand rail #22 face down on the table surface. See Figure 18. Care must be used to avoid scratching rail. Find two corner pockets #27, and four bolts #28. Attach corner pockets to rails by inserting pocket posts into the rail ends. See Figure 18. Pull rail ends snugly against pocket edges before tightening bolts. Repeat procedure using the other end, left and right hand rail.

Install studs #31, 3 pcs per each rail as per **Figure 18** This studs only require a snug fit.

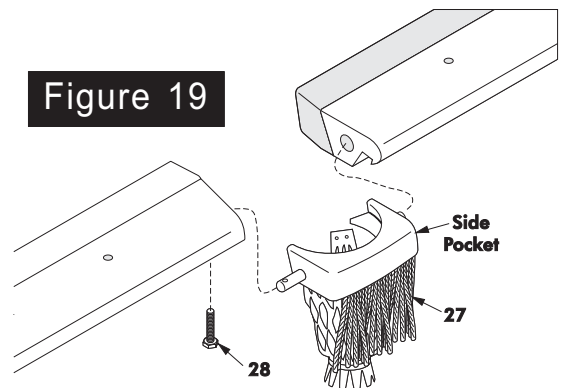
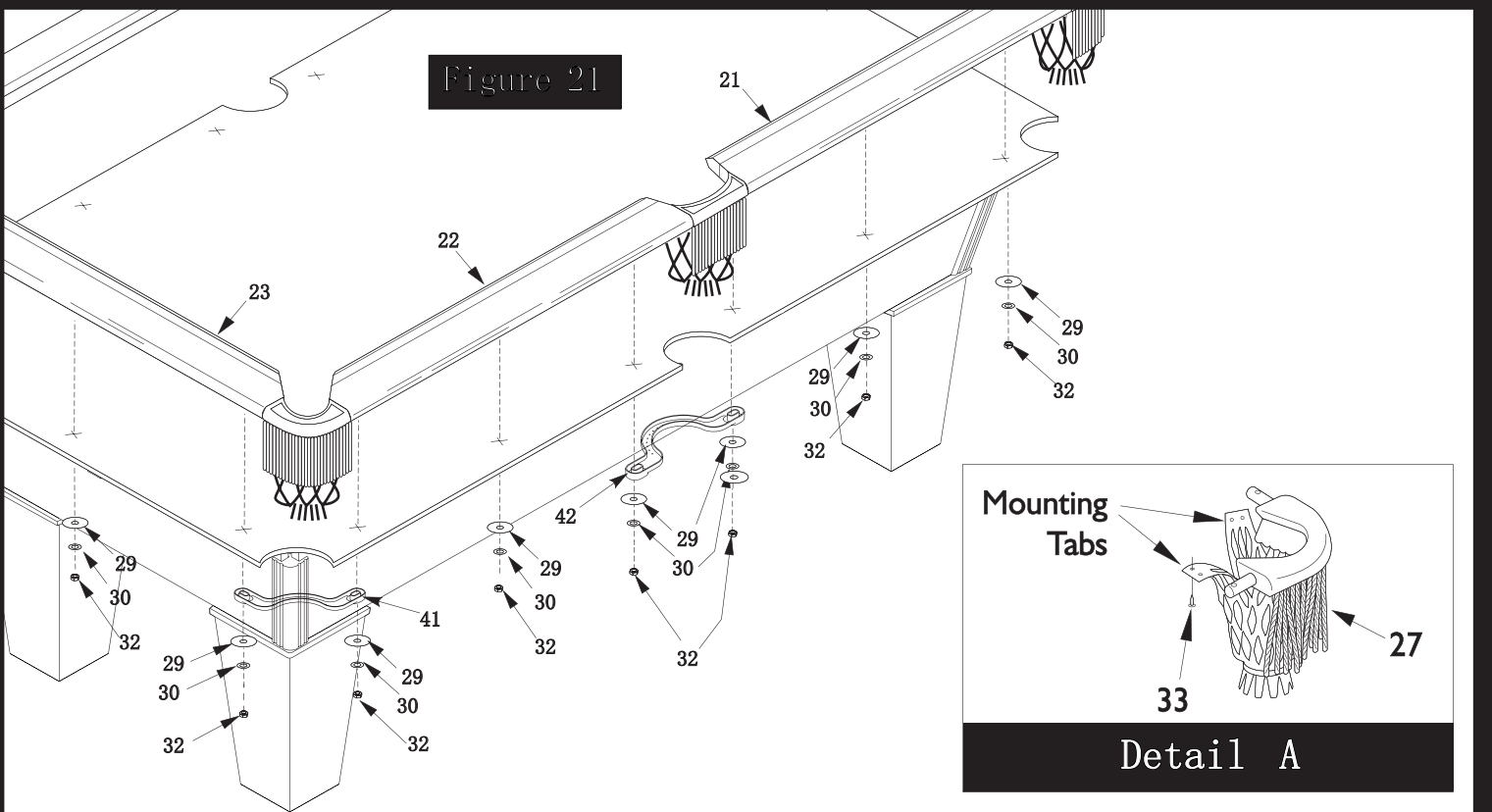
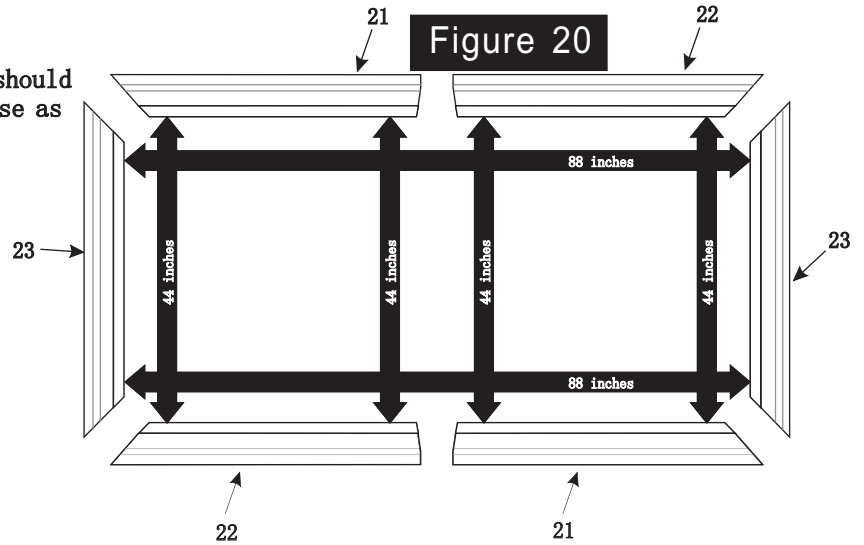

Figure 19

47. The rail cushion nose to nose dimension should measure 44 inches by 88 inches or as close as possible. See Figure 20

NOTE: Look along the nose rubber of the side rails to be sure they align.



NOTE: Find the parts needed to complete this step and position them on the floor around the table.

48. Secure rails and #41 & #42 pocket blocks to the playing surface by attaching, three dome washers #29, three lock washer #30 and three hex nuts #32, to studs #31, Tighten these nuts tight. See Figure 21.
49. Attach pocket nets to the pocket blocks installed earlier using one screw #33 for each mounting tab. See Detail A and Figure 21.

50. A day later the table may have settled so check the levelness of the table the same way you did in step 14. If the table is not level raise the low corner by shimming up that corner's leg.

ONE YEAR LIMITED WARRANTY

This consumer warranty extends to the original consumer purchase of any ESCALADE® SPORTS Product (hereinafter referred as the "Product").

WARRANTY DURATION: This Product is warranted to the original consumer purchase of a period of one (1) year from the original purchase.

WARRANTY COVERAGE: ESCALADE SPORTS warrants to the original Consumer Purchaser that any Product of its manufacture is free from defects in material and workmanship when used for the intended purpose under normal use and conditions. THIS WARRANTY IS VOID IF THE PRODUCT HAS BEEN DAMAGED BY ACCIDENT, UNREASONABLE USE, NEGLIGENCE, IMPROPER SERVICE, FAILURE TO FOLLOW INSTRUCTIONS PROVIDED WITH THE PRODUCT OR OTHER CAUSES NOT ARISING OUT OF DEFECTS IN MATERIAL AND WORKMANSHIP.

WARRANTY PERFORMANCE: During the above one (1) year warranty period, ESCALADE SPORTS shall repair or replace with a comparable model, and/or Product, or component thereof, for any product which may prove defective under normal use and proper care, and which our examination shall disclose to our satisfaction to be thus defective, please contact our Warranty Dept.

1-866-556-2757 / Warranty Dept.

Or Write us at:

Escalade Sports, Inc. - P.O. Box 889, Evansville, IN 47706 - Attn: Warranty Dept.

Or E-mail us at:

billiardtables@escaladesports.com

Other than shipping requirements no charge will be made for such repair or replacement of in-warranty Products. ESCALADE® SPORTS strongly recommends that the Product is insured for value prior to mailing.



WARRANTY DISCLAIMERS: ANY IMPLIED WARRANTIES ARISING OUT OF THIS SALE, INCLUDING BUT NOT LIMITED TO THE IMPLIED WARRANTIES OF MERCHANTABILITY AND FITNESS FOR A PARTICULAR PURPOSE, ARE LIMITED IN DURATION TO THE ABOVE WARRANTY PERIOD. ESCALADE SPORTS SHALL NOT BE LIABLE FOR LOSS OF USE OF THE PRODUCT OR OTHER CONSEQUENTIAL OR INCIDENTAL COSTS, EXPENSES OR DAMAGES INCURRED BY THE CONSUMER OF ANY OTHER USE.

Some states do not allow the exclusion or limitation of implied warranties or consequential or incidental damages, so the above limitations or exclusions may not apply to you.

LEGAL REMEDIES: This warranty gives you specific legal rights and you may also have other rights which may vary from state to state.

1291W REPLA CEMENT PARTS

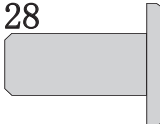
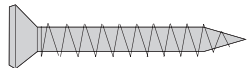
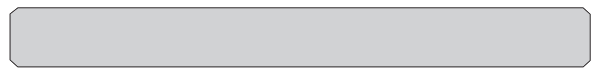
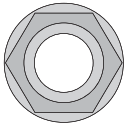
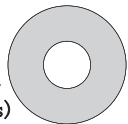
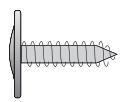
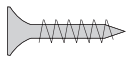
KEY#	PART#	DESCRIPTION	QTY	KEY#	PART#	DESCRIPTION	QTY
1	2W-7669-08	END CABINET PANEL	2	22	2A-7150-08	RIGHT RAIL ASSY.	2
2	2W-7670-08	SIDE CABINET PANEL	2	23	2A-7151-08	END RAIL ASSY.	2
3	2W-7172-00	DOVE BLOCK	8	24	2W-7674-08	SIDE BLIND	4
4	2W-7671-08	WOODEN CONER POST	4	25	2W-7675-08	END BLIND	2
5	1B-6611-00	#8 X 5/8" FLATHEAD SCREW	88	26	2S-6507-00	APRON BRACKET	18
6	2W-7174-00	LEG BLOCK	4	27	4A-7088-00	POCKET PAC-BLK-BLK FR (SET OF 6) - MIZ	1
7	1B-6628-00	#10 X 1-1/4" FLATHEAD SCREW	54	28	1B-6613-00	5/16-18 X 3/4 ROUND HEAD BOLT	12
8	2W-7175-00	LEG	4	29	2B-6144-00	5/16" DOME WASHER	18
9	1B-6629-00	3/8-16 X 5" STUD	4	30	2B-6145-00	5/16" LOCK WASHER	18
10	2B-6138-00	3/8" HEAVY FLATWASHER	4	31	1B-6620-00	5/16-18 X 2-1/2 STUD	18
11	901-28	3/8-16 HEX NUT	4	32	2B-6025-00	5/16-18 HEX NUT	18
12	2W-7672-00	CENTER BEAM	1	33	801-601B	#8 X 1/2 PHILLIPS HEAD SCREW	12
13	2W-7673-00	CROSS BEAM	2	34	4L-7608-00	MIZERAK NAMEPLATE	1
14	1B-6630-00	1/4-20 X 2" PHILLIPS HEAD SCREW	22	35	5A-7135-10	PLAYFIELD CLOTH	1
15	2B-6151-00	1/4" FLATWASHER	22	36	818-29	ADHESIVE SPRAY	1
16	7B-6304-00	1/4-20 DOWEL CONNECTOR	6	37	818-23	SHIM (SHEET OF 20)	1
17	2W-7180-00	SCREW BLOCK	4	38	5A-6869-00	GROUT PACKAGE	1
18	2W-6029-00	SLATRON PLAYFIELD END	2	39	818-41	LEG SHIM STOCK	1
	809-551	SLATE PLAYFIELD END	2	40	?	THIS OWNERS MANUAL	1
19	2W-6030-00	SLATRON PLAYFIELD CENTER	1	41	3M-6149-01	CORNER POCKET BLOCK	4
	809-552	SLATE PLAYFIELD CENTER	1	42	3M-6150-01	SIDE POCKET LOCK	2
21	2A-7149-08	LEFT RAIL ASSY.	2	43		LEVEL BRACE	8
				44		WOODEN LEG PLATE	4

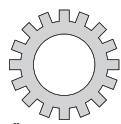
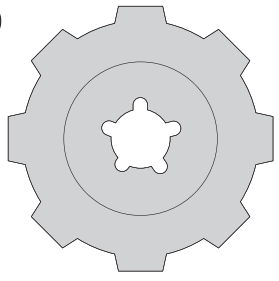
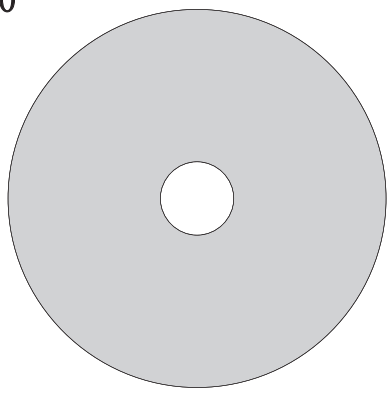
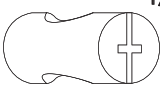
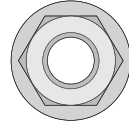
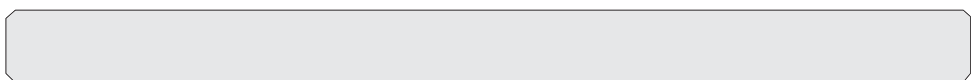
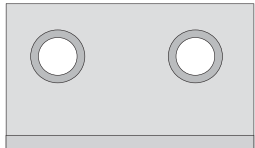
28  5/16-18 x 3/4" Round Head Bolt (12 pieces)	7  #10 x 1-1/4 Flat Head Screw (56 pieces)	31  5/16 - 18 x 3" Stud (18 pieces)	
11 3/8-16 Hex Nut (4 pieces) 	15 1/4" Flat Washer (22 pieces) 	33  #8 x 1/2" Washer Head Screw (12 pieces)	5  #8 x 5/8" Flat Head Screw (88 pieces)
14  1/4-20x 2" Phillips Head Screw (22 pieces)	30  5/16" Lock Washer (18 pieces)	29  5/16" Dome Washer (18 pieces)	
10  3/8" Heavy Flatwasher (4 pieces)	16 1/4- 20 Dowel Connector (6 pieces) 	32  5/16-18 Hex Nut (18 pieces)	9 3/8 - 16 x 5" Stud (4 pieces) 
	26  PRON BRACKET (18 PIECES)		

HARDWARE IDENTIFIER

P1291W

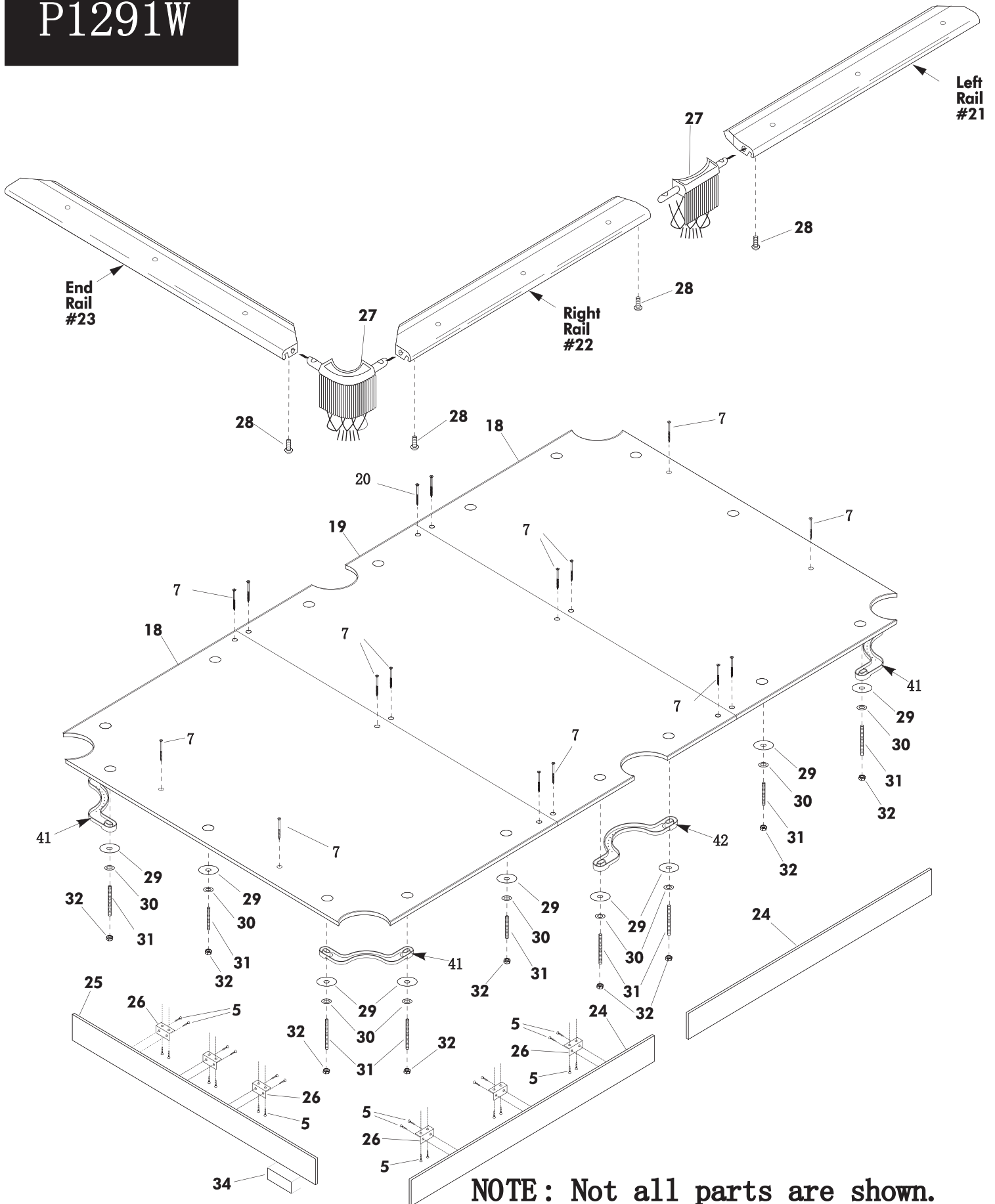

**NOTE: Not all parts are shown.
Also see page 15**

P1291W

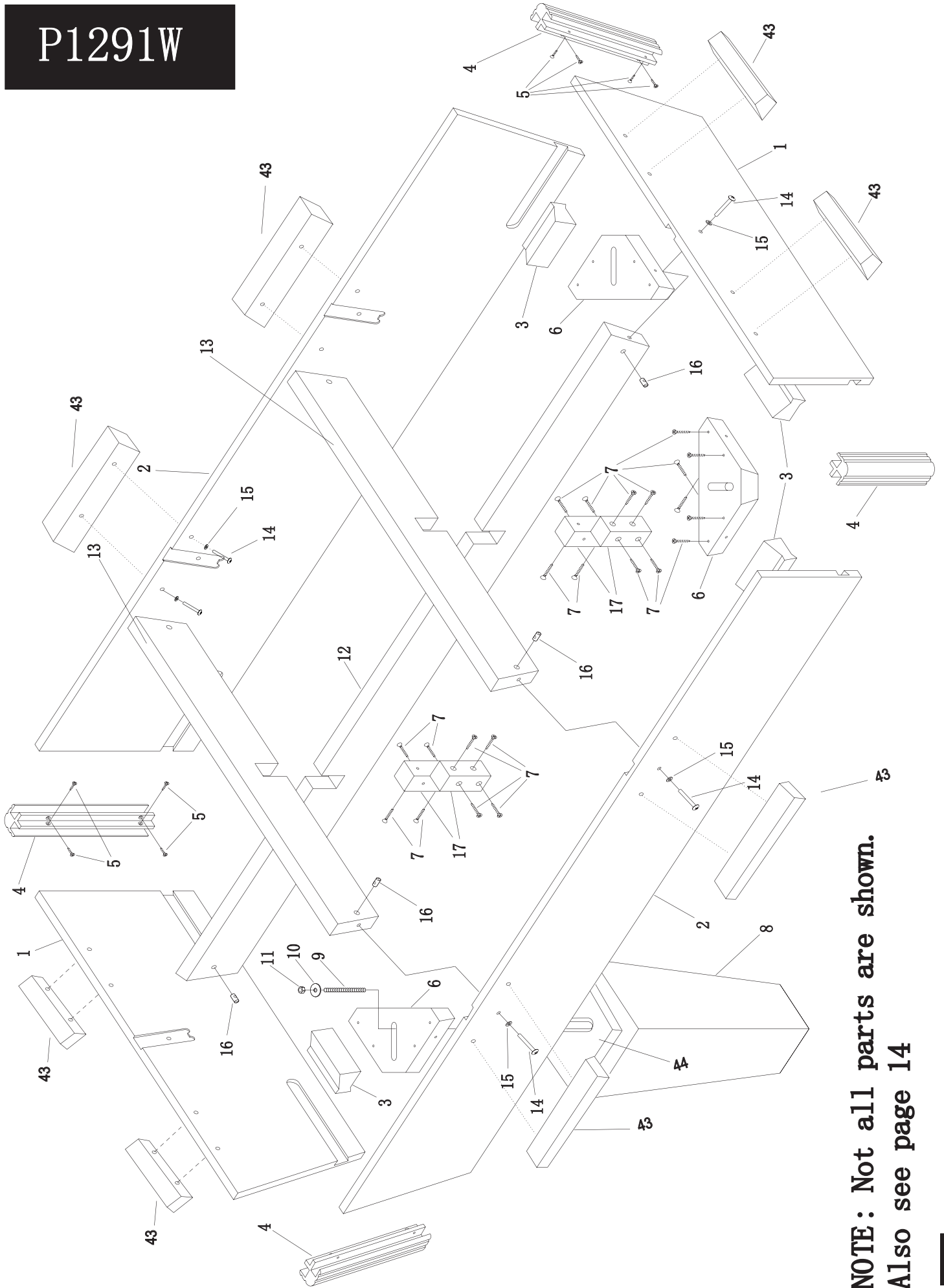

**NOTE: Not all parts are shown.
Also see page 14**