

## User's Manual



## *XTRA Series: XPA 1002, XPA 2001-70V, and XPA 2001-100V*

### Half-Rack 2-Channel and Mono Channel Audio Power Amplifiers



# Precautions

---

## English

### Important Safety Instructions

 **CAUTION** This symbol is intended to alert the user of important operating and maintenance (servicing) instructions in the literature provided with the equipment.

 **WARNING** This symbol is intended to alert the user of the presence of uninsulated dangerous voltage within the product's enclosure that may present a risk of electric shock. On the product, risk of shock may be indicated by this symbol: 

1. Read these instructions.
2. Keep these instructions.
3. Heed all warnings.
4. Follow all instructions.
5. Do not use this apparatus near water.
6. Clean only with dry cloth.
7. Do not block any ventilation openings. Install in accordance with the manufacturer's instructions.
8. Do not install near any heat sources such as radiators, heat registers, stoves, or other apparatus (including amplifiers) that produce heat.
9. Do not defeat the safety purpose of the polarized or grounding-type plug. A polarized plug has two blades with one wider than the other. A grounding type plug has two blades and a third grounding prong. The wide blade or the third prong is provided for your safety. If the provided plug does not fit into your outlet, consult an electrician for replacement of the obsolete outlet.

#### **WARNING**

**Power sources** • This equipment should be operated only from the power source indicated on the product. This equipment is intended to be used with a main power system with a grounded (neutral) conductor. The third (grounding) pin is a safety feature, do not attempt to bypass or disable it.

**Power disconnection** • To remove power from the equipment safely, remove all power cords from the rear of the equipment, or the desktop power module (if detachable), or from the power source receptacle (wall plug).

10. Protect the power cord from being walked on or pinched particularly at plugs, convenience receptacles, and the point where they exit from the apparatus.
11. Only use attachments/accessories specified by the manufacturer.
12. Unplug this apparatus during lightning storms or when unused for long periods of time.
13. **WARNING:** To reduce the risk of fire or electric shock, do not expose this apparatus to rain or moisture.

This apparatus shall not be exposed to dripping or splashing and no objects filled with liquids, such as vases shall be placed on the apparatus.

14. Refer all servicing to qualified service personnel. Servicing is required when the apparatus has been damaged in any way, such as power-supply cord or plug is damaged, liquid has been spilled or objects have fallen into the apparatus, the apparatus has been exposed to rain or moisture, does not operate normally, or has been dropped.
15. **WARNING:** This apparatus is a Class I product. This product must be connected to a MAINS socket outlet with a protective earthing connection.
16. The mains plug is used as the disconnect device and shall remain readily operable.

## Consignes de Sécurité • Français



Ce symbole sert à avertir l'utilisateur que la documentation fournie avec le matériel contient des instructions importantes concernant l'exploitation et la maintenance (réparation).



Ce symbole sert à avertir l'utilisateur de la présence dans le boîtier de l'appareil de tensions dangereuses non isolées posant des risques d'électrocution.

### Attention

**Lire les instructions** • Prendre connaissance de toutes les consignes de sécurité et d'exploitation avant d'utiliser le matériel.

**Conserver les instructions** • Ranger les consignes de sécurité afin de pouvoir les consulter à l'avenir.

**Respecter les avertissements** • Observer tous les avertissements et consignes marqués sur le matériel ou présentés dans la documentation utilisateur.

**Éviter les pièces de fixation** • Ne pas utiliser de pièces de fixation ni d'outils non recommandés par le fabricant du matériel car cela risquerait de poser certains dangers.

## Sicherheitsanleitungen • Deutsch



Dieses Symbol soll dem Benutzer in der im Lieferumfang enthaltenen Dokumentation besonders wichtige Hinweise zur Bedienung und Wartung (Instandhaltung) geben.



Dieses Symbol soll den Benutzer darauf aufmerksam machen, daß im Inneren des Gehäuses dieses Produktes gefährliche Spannungen, die nicht isoliert sind und die einen elektrischen Schock verursachen können, herrschen.

### Achtung

**Lesen der Anleitungen** • Bevor Sie das Gerät zum ersten Mal verwenden, sollten Sie alle Sicherheits- und Bedienungsanleitungen genau durchlesen und verstehen.

**Aufbewahren der Anleitungen** • Die Hinweise zur elektrischen Sicherheit des Produktes sollten Sie aufbewahren, damit Sie im Bedarfsfall darauf zurückgreifen können.

**Befolgen der Warnhinweise** • Befolgen Sie alle Warnhinweise und Anleitungen auf dem Gerät oder in der Benutzerdokumentation.

**Keine Zusatzgeräte** • Verwenden Sie keine Werkzeuge oder Zusatzgeräte, die nicht ausdrücklich vom Hersteller empfohlen wurden, da diese eine Gefahrenquelle darstellen können.

## Instrucciones de seguridad • Español



Este símbolo se utiliza para advertir al usuario sobre instrucciones importantes de operación y mantenimiento (o cambio de partes) que se desean destacar en el contenido de la documentación suministrada con los equipos.



Este símbolo se utiliza para advertir al usuario sobre la presencia de elementos con voltaje peligroso sin protección aislante, que puedan encontrarse dentro de la caja o alojamiento del producto, y que puedan representar riesgo de electrocución.

### Precucion

**Leer las instrucciones** • Leer y analizar todas las instrucciones de operación y seguridad, antes de usar el equipo.

**Conservar las instrucciones** • Conservar las instrucciones de seguridad para futura consulta.

**Obedecer las advertencias** • Todas las advertencias e instrucciones marcadas en el equipo o en la documentación del usuario, deben ser obedecidas.

**Evitar el uso de accesorios** • No usar herramientas o accesorios que no sean específicamente recomendados por el fabricante, ya que podrían implicar riesgos.

## Avertissement

**Alimentations** • Ne faire fonctionner ce matériel qu'avec la source d'alimentation indiquée sur l'appareil. Ce matériel doit être utilisé avec une alimentation principale comportant un fil de terre (neutre). Le troisième contact (de mise à la terre) constitue un dispositif de sécurité : n'essayez pas de la contourner ni de la désactiver.

**Déconnexion de l'alimentation** • Pour mettre le matériel hors tension sans danger, déconnectez tous les cordons d'alimentation de l'arrière de l'appareil ou du module d'alimentation de bureau (s'il est amovible) ou encore de la prise secteur.

**Protection du cordon d'alimentation** • Acheminer les cordons d'alimentation de manière à ce que personne ne risque de marcher dessus et à ce qu'ils ne soient pas écrasés ou pincés par des objets.

**Réparation-maintenance** • Faire exécuter toutes les interventions de réparation-maintenance par un technicien qualifié. Aucun des éléments internes ne peut être réparé par l'utilisateur. Afin d'éviter tout danger d'électrocution, l'utilisateur ne doit pas essayer de procéder lui-même à ces opérations car l'ouverture ou le retrait des couvercles risquent de l'exposer à de hautes tensions et autres dangers.

**Fentes et orifices** • Si le boîtier de l'appareil comporte des fentes ou des orifices, ceux-ci servent à empêcher les composants internes sensibles de surchauffer. Ces ouvertures ne doivent jamais être bloquées par des objets.

**Lithium Batterie** • Il a danger d'explosion s'il y a remplacement incorrect de la batterie. Remplacer uniquement avec une batterie du même type ou d'un type équivalent recommandé par le constructeur. Mettre au rebut les batteries usagées conformément aux instructions du fabricant.

## Vorsicht

**Stromquellen** • Dieses Gerät sollte nur über die auf dem Produkt angegebene Stromquelle betrieben werden. Dieses Gerät würde für eine Verwendung mit einer Hauptstromleitung mit einem geerdeten (neutralen) Leiter konzipiert. Der dritte Kontakt ist für einen Erdschluß, und stellt eine Sicherheitsfunktion dar. Diese sollte nicht umgangen oder außer Betrieb gesetzt werden.

**Stromüberbrechung** • Um das Gerät auf sichere Weise vom Netz zu trennen, sollten Sie alle Netzkabel aus der Rückseite des Gerätes, aus der externen Stromversorgung (falls dies möglich ist) oder aus der Wandsteckdose ziehen.

**Schutz des Netzkabels** • Netzkabel sollten stets so verlegt werden, daß sie nicht im Weg liegen und niemand darauf treten kann oder Objekte darauf- oder unmittelbar dagegen gestellt werden können.

**Wartung** • Alle Wartungsmaßnahmen sollten nur von qualifiziertem Servicepersonal durchgeführt werden. Die internen Komponenten des Gerätes sind wartungsfrei. Zur Vermeidung eines elektrischen Schocks versuchen Sie in keinem Fall, dieses Gerät selbst öffnen, da beim Entfernen der Abdeckungen die Gefahr eines elektrischen Schlages und/oder andere Gefahren bestehen.

**Schlitze und Öffnungen** • Wenn das Gerät Schlitze oder Löcher im Gehäuse aufweist, dienen diese zur Vermeidung einer Überhitzung der empfindlichen Teile im Inneren. Diese Öffnungen dürfen niemals von anderen Objekten blockiert werden.

**Lithium-Batterie** • Explosionsgefahr, falls die Batterie nicht richtig ersetzt wird. Ersetzen Sie die verbrauchte Batterie nur durch den gleichen oder einen vergleichbaren Batterietyp, der auch vom Hersteller empfohlen wird. Entsorgen Sie verbrauchte Batterien bitte gemäß den Herstelleranweisungen.

## Advertencia

**Alimentación eléctrica** • Este equipo debe conectarse únicamente a la fuente/tipo de alimentación eléctrica indicada en el mismo. La alimentación eléctrica de este equipo debe provenir de un sistema de distribución general con conductor neutro a tierra. La tercera pata (puesta a tierra) es una medida de seguridad, no puentearla ni eliminarla.

**Desconexión de alimentación eléctrica** • Para desconectar con seguridad la alimentación eléctrica al equipo, desenchufar todos los cables de alimentación en el panel trasero del equipo, o desenchufar el módulo de alimentación (si fuera independiente), o desenchufar el cable del receptáculo de la pared.

**Protección del cable de alimentación** • Los cables de alimentación eléctrica se deben instalar en lugares donde no sean pisados ni apretados por objetos que se puedan apoyar sobre ellos.

**Reparaciones/mantenimiento** • Solicitar siempre los servicios técnicos de personal calificado. En el interior no hay partes a las que el usuario deba acceder. Para evitar riesgo de electrocución, no intentar personalmente la reparación/mantenimiento de este equipo, ya que al abrir o extraer las tapas puede quedar expuesto a voltajes peligrosos u otros riesgos.

**Ranuras y aberturas** • Si el equipo posee ranuras o orificios en su caja/alojamiento, es para evitar el sobrecalentamiento de componentes internos sensibles. Estas aberturas nunca se deben obstruir con otros objetos.

**Batería de litio** • Existe riesgo de explosión si esta batería se coloca en la posición incorrecta. Cambiar esta batería únicamente con el mismo tipo (o su equivalente) recomendado por el fabricante. Desachar las baterías usadas siguiendo las instrucciones del fabricante.

## 安全须知 • 中文



这个符号提示用户该设备用户手册中有重要的操作和维护说明。



这个符号警告用户该设备机壳内有暴露的危险电压，有触电危险。

### 注意

**阅读说明书** • 用户使用该设备前必须阅读并理解所有安全和使用说明。

**保存说明书** • 用户应保存安全说明书以备将来使用。

**遵守警告** • 用户应遵守产品和用户指南上的所有安全和操作说明。

**避免追加** • 不要使用该产品厂商没有推荐的工具或追加设备，以避免危险。

### 警告

**电源** • 该设备只能使用产品上标明的电源。设备必须使用有地线的供电系统供电。第三条线（地线）是安全设施，不能不用或跳过。

**拔掉电源** • 为安全地从设备拔掉电源，请拔掉所有设备后或桌面电源的电源线，或任何接到市电系统的电源线。

**电源线保护** • 妥善布线，避免被踩踏，或重物挤压。

**维护** • 所有维修必须由认证的维修人员进行。设备内部没有用户可以更换的零件。为避免出现触电危险不要自己试图打开设备盖子维修该设备。

**通风孔** • 有些设备机壳上有通风槽或孔，它们是用来防止机内敏感元件过热。不要用任何东西挡住通风孔。

**锂电池** • 不正确的更换电池会有爆炸的危险。必须使用与厂家推荐的相同或相近型号的电池。按照生产厂的建议处理废弃电池。

## FCC Class B Notice

This equipment has been tested and found to comply with the limits for a Class B digital device, pursuant to part 15 of the FCC Rules. These limits are designed to provide reasonable protection against harmful interference in a residential installation. This equipment generates, uses, and can radiate radio frequency energy and, if not installed and used in accordance with the instructions, may cause harmful interference to radio communications. However, there is no guarantee that the interference will not occur in a particular installation. If this equipment does cause harmful interference to radio or television reception, which can be determined by turning the equipment off and on, the user is encouraged to try to correct the interference by one or more of the following measures:

- Reorient or relocate the receiving antenna.
- Increase the separation between the equipment and receiver.
- Connect the equipment into an outlet on a circuit different from that to which the receiver is connected.
- Consult the dealer or an experienced radio/TV technician for help.

### NOTE

*This unit was tested with shielded cables on the peripheral devices. Shielded cables must be used with the unit to ensure compliance.*

# Table of Contents

---

<b>Chapter One • Introduction</b> .....	1-1
About this Manual .....	1-2
Terms used in this manual .....	1-2
Features .....	1-2
<b>Chapter Two • Installation</b> .....	2-1
Application Examples.....	2-2
Mounting the XPA 1002 and XPA 2001 .....	2-3
Tabletop use .....	2-3
UL rack mounting guidelines .....	2-3
Rack mounting .....	2-4
Rack mounting ventilation recommendations .....	2-5
Flexible conduit adapter kit installation .....	2-6
UL requirements .....	2-7
Installing the flexible conduit kit .....	2-7
<b>Chapter Three • Operation</b> .....	3-1
Front Panel Features and Operation .....	3-2
Rear Panel Features and Operation.....	3-4
Remote volume control .....	3-11
Bridged mono output.....	3-11
<b>Appendix A • Reference</b> .....	A-1
Specifications .....	A-2
Included Parts .....	A-5
Optional Accessories .....	A-6

## **Table of Contents, cont'd**

---

*All trademarks mentioned in this manual are the properties of their respective owners.*



**XTRA Series**

# 1

# Chapter One

## Introduction

About this Manual

Features

# Introduction

---

## About this Manual

This manual contains information about the Extron XTRA Series of power amplifiers: the XPA 1002 two-channel stereo audio power amplifier and the XPA 2001-70V and XPA 2001-100V mono audio power amplifiers.

## Terms used in this manual

The terms “amplifier” and “power amplifier” are used interchangeably in this manual to refer to all of the XPA models. XPA 2001 refers to both the XPA 2001-70V and the XPA 2001-100V.

## Features

**Inputs** — Balanced or unbalanced stereo on a captive screw connector.

**Speaker outputs** — Screw-lock, 5 mm captive screw connector.

**Continuous power output for larger rooms** —

- XPA 1002: 60 watts rms per channel at 8 ohms; 100 watts rms per channel at 4 ohms.
- XPA 2001-70V: 200 watts rms for 70 volt speaker systems.
- XPA 2001-100V: 200 watts rms for 100 volt speaker systems.

**Professional grade amplifier design** —

- Less than 0.05% total harmonic distortion plus noise
- Better than 100 dB signal-to-noise

**ENERGY STAR® qualified amplifier** — The XTRA Series of amplifiers are energy efficient products that conserve energy and reduce operating costs.

**Highly efficient Class D amplifier design** — The XTRA Series of amplifiers generate substantially less heat than conventional amplifier designs, making them ideal for installation in equipment racks and lecterns with very limited ventilation. They consume 10 watts when idle and less than 1 watt in standby mode.

**Extron patented CDRS™ - Class D ripple suppression** — A patented, exclusive technology from Extron that eliminates the high frequency switching ripple and EMI emissions found in typical Class D amplifiers. CDRS enables Extron power amplifiers to be situated near wireless A/V devices without RF interference.



- 
- Convection cooled** — The XTRA Series of amplifiers are convection cooled without the need for fans, ensuring quiet, reliable operation.
- Ultra low inrush current - no need for power sequencing** — Allows many XTRA Series amplifiers to be powered on simultaneously without overloading power circuits. This eliminates the need for power sequencing.
- Flexible Conduit Adapter Kit, part # 70-228-02** — Suitable for Use in Other Environmental Air Space in Accordance with Section 300.22, (C) of the National Electrical Code only when used with optional Flexible Conduit Adapter Kit part #70-228-02.
- Auto-standby with fast power-up** — The amplifiers automatically enter into a standby mode after one hour of inactivity, dramatically reducing power consumption. They quickly return to full power status upon signal detection.
- Rear panel level controls** — Provide attenuation of input signals for setting proper audio system gain staging as well as two-zone applications. They are located on the rear panel to prevent unauthorized or accidental tampering of the level adjustments.
- Multiple protection circuits** — Activate during excessive clipping, thermal overload, or DC faults to prevent damage to the amplifier and speakers.
- Remote standby port** — Enables the amplifiers to be remotely powered down when not in use, reducing operating cost.
- Remote volume and mute control port** — This port allows the amplifiers to be remotely controlled using the optional Extron VCM 100 Series volume and mute or VC 50 volume controllers.
- Bridgeable outputs** — The power output of the XPA 1002 can be effectively doubled by bridging the output. A mono source is wired to both the left and right input while the output is wired for bridged operation. Bridging allows power to be output at 200 watts into 8 ohms or 120 watts into 16 ohms. The minimum load impedance when bridging is 8 ohms. See chapter 3 for complete wiring details.
- Screw lock, 5 mm captive screw speaker connectors** — Enable simple, secure connections with 22 to 14 AWG speaker cables.

## Introduction, cont'd

---

**Front and rear-mounted signal and protection indication LEDs**  
— Provide convenient indication of amplifier operation from both sides of an equipment rack.

**Internal international power supply** — The 100-240 VAC, 50-60 Hz universal power supply provides worldwide power compatibility.



**XTRA Series**

# 2

## **Chapter Two**

### **Installation**

Application Examples

Mounting the XPA 1002 and XPA 2001

# Installation

## **WARNING**

*Installation and service must be performed by authorized personnel only. See "UL rack mounting guidelines" on the following page.*

## Application Examples

The following illustrations are application examples for the XPA 1002 and the XPA 2001.

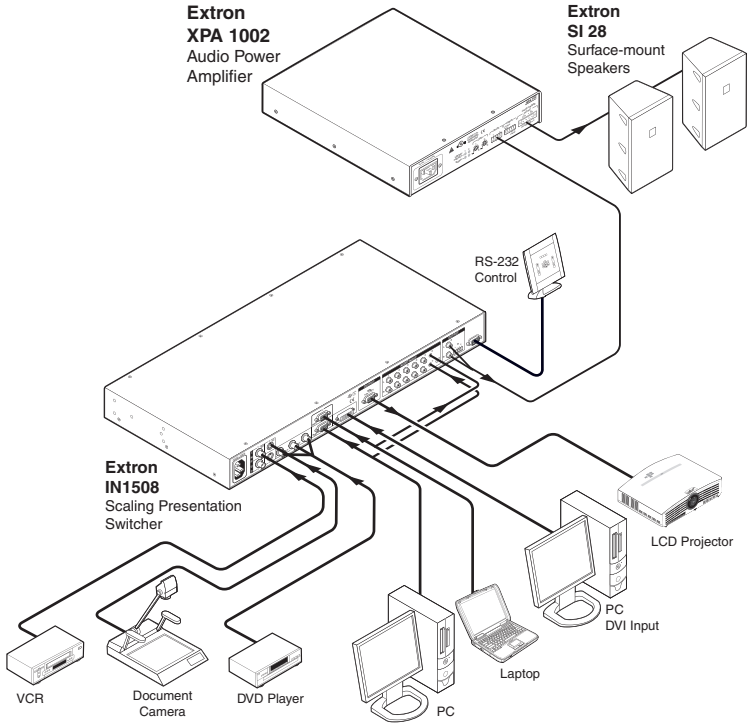

***XPA 1002 application example***

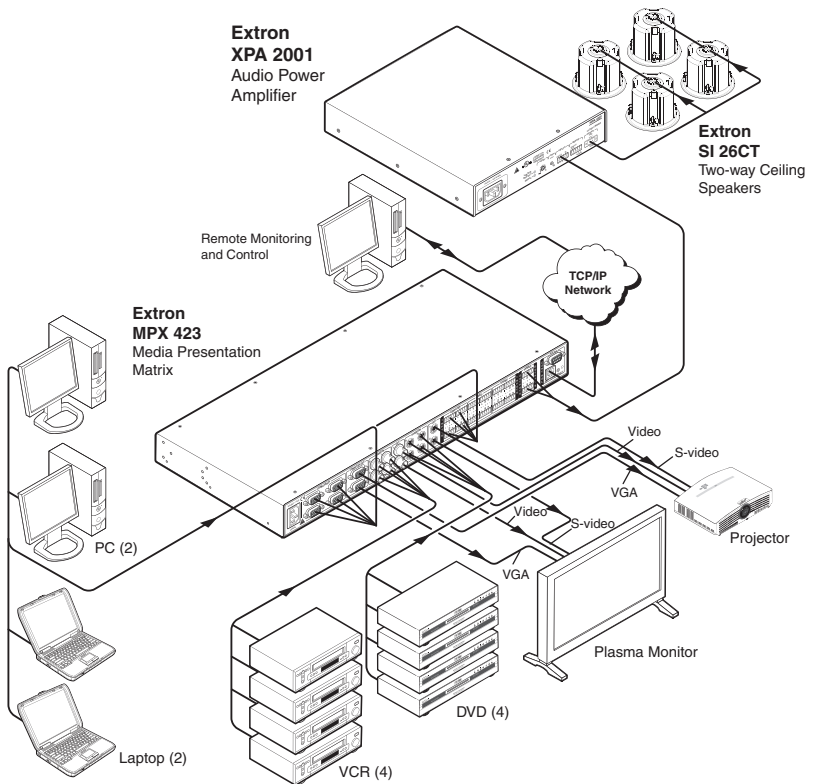

### ***XPA 2001 Series application example***

## **Mounting the XPA 1002 and XPA 2001**

The XPA 1002 and XPA 2001 audio amplifiers can be set on a table, mounted on a rack shelf, or mounted in the plenum space above a ceiling-mounted projector.

### **Tabletop use**

Four self-adhesive rubber feet are included with the audio amplifier.

For tabletop use, attach one foot at each corner of the bottom side of the unit and place the unit in the desired location.

### **UL rack mounting guidelines**

The following Underwriters Laboratories (UL) guidelines pertain to the safe installation of the equipment in a rack.

## Installation, cont'd

---

1. **Elevated operating ambient temperature** — If installed in a closed or multi-unit rack assembly, the operating ambient temperature of the rack environment may be greater than room ambient temperature. Therefore, install the equipment in an environment compatible with the maximum ambient temperature ( $T_{ma} = +122\text{ }^{\circ}\text{F}, +50\text{ }^{\circ}\text{C}$ ) specified by Extron.
2. **Reduced air flow** — Install the equipment in a rack so that the amount of air flow required for safe operation of the equipment is not compromised.
3. **Mechanical loading** — Mount the equipment in the rack so that a hazardous condition is not achieved due to uneven mechanical loading.
4. **Circuit overloading** — Connect the equipment to the supply circuit and consider the effect that circuit overloading might have on overcurrent protection and supply wiring. Appropriate consideration of equipment nameplate ratings should be used when addressing this concern.
5. **Reliable earthing (grounding)** — Maintain reliable grounding of rack-mounted equipment. Pay particular attention to supply connections other than direct connections to the branch circuit (e.g. use of power strips).

### Rack mounting

The XPA 1002 or XPA 2001 can be mounted in a rack shelf using the optional RSU 129 1U Universal rack shelf (Extron part #60-190-01) or the 1U Basic rack shelf (Extron part #60-604-01), as follows.

1. If feet were installed on the bottom of the amplifier, remove them.
2.
  - Place the amplifier on one half of the rack shelf.
  - Align the front of the amplifier with the front of the shelf, and align the threaded holes on the bottom of the amplifier with the holes in the rack shelf.
3.
  - Attach the amplifier to the rack shelf with the two provided 4-40 x 3/16" machine screws.
  - Insert the screws from the underside of the shelf, and securely fasten them into diagonally-opposite corners.

See the following illustration.

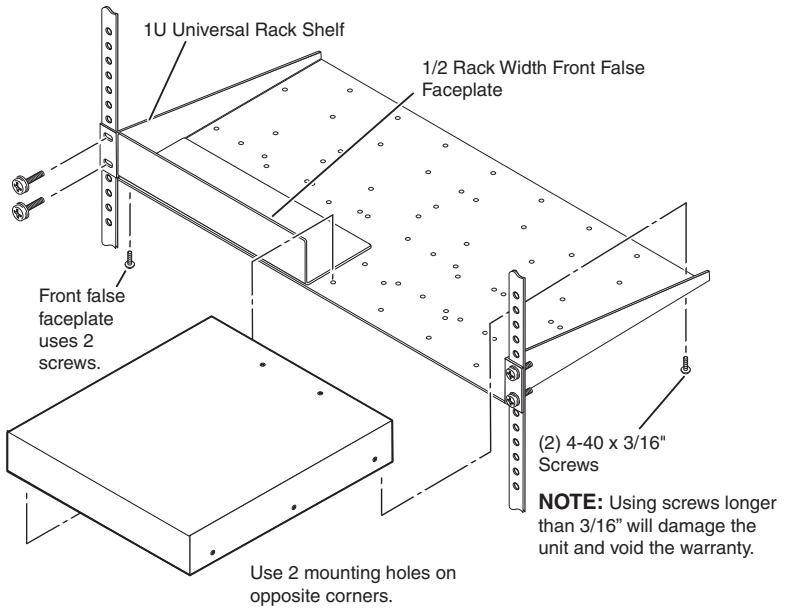

### **Rack mounting of the amplifier**

4. Attach the false front panel (provided with rack shelf part #60-190-01) to the unoccupied side of the rack (as shown above), or install a second half-rack-width device in that side by repeating steps 1 through 3.
5. Attach the rack shelf to the rack using four 10-32 x 3/4" bolts (provided). Insert the bolts through #10 beveled washers, then through the holes in the rack, as shown above.

### **Rack mounting ventilation recommendations**

Excessive heat can decrease the optimal lifetime of the power amplifier. An **over temp** indicator LED on the front panel of the amplifier lights red whenever the recommended operating temperature has been exceeded (see "Front Panel Features and Operation" in chapter 3).

To reduce the chances for an **over temp** condition, the XPA(s) should be arranged in a rack environment so that adequate airflow is available both above and below the XPA whenever possible. No more than two XPAs should be arranged one-on-top-of-the-other in a rack without an open space between them, as shown in the following illustration. An XPA can also be arranged above or below another non-XPA device, but there must be an open space both above and below those devices.

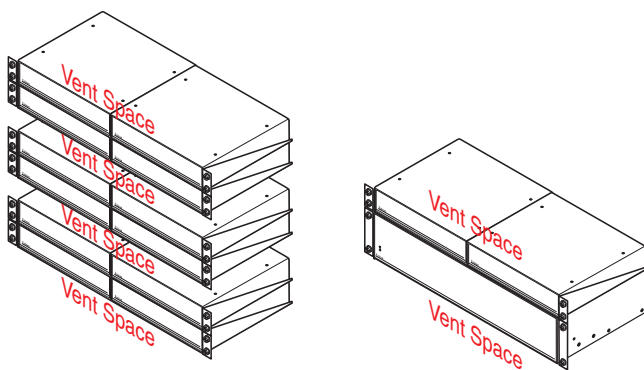

**Allow sufficient spacing for adequate ventilation**

### Flexible conduit adapter kit installation

**WARNING** *The circuit breaker used for this connection should be rated no lower than 20 amps and no greater than 30 amps.*

**WARNING** *This unit must be installed in accordance with the National Electrical Code and with all local codes. An ALL-POLE MAINS SWITCH with a contact separation of at least 3 mm in each pole shall be incorporated in the electrical installation of the building. The installation shall be carried out in accordance with all applicable installation rules.*

**WARNING** *Installation and service must be performed by a qualified electrician only.*

**CAUTION** *A UL listed electrical distribution box is recommended for the termination of the conduit opposite the XPA. See the following "UL requirements" section.*

The optional Flexible Conduit Adapter Kit (Extron part #70-228-02) consists of

- One EMT adapter plate
- One 6-foot long electrical conduit
- Three 7.5 feet, 18-gauge spade connector power wires
- One UL rated zip tie wrap
- Three auxiliary crimp style spade connectors designed for 14- to 16-gauge wires

**NOTE** *If needed, Extron recommends using a UL-rated crimp tool to terminate the spade connectors. One recommended choice is the Molex crimp tool (Molex part #19285-0008).*



---

The kit provides a convenient means to replace the XPA's IEC power cord with conduit, where required by local codes.

**CAUTION** *Make sure that the source device and the XPA are turned off and disconnected from the power source before you begin.*

### **UL requirements**

The Underwriters Laboratories (UL) requirements listed below pertain to the installation of the flexible conduit onto a XPA 1002 or XPA 2001.

- This unit is not to be used beyond its rated voltage range.
- This unit must be wired to a UL listed distribution box.

**NOTE** *The UL approved electrical distribution box is not included with either the XPA or the Flexible Conduit Adapter Kit; the installer is responsible for obtaining and installing the box.*

### **Installing the flexible conduit kit**

Install flexible conduit to the XPA by following the steps below.

1. Unplug the IEC power cord from the power amplifier.
2. Remove the 8 screws from the top and sides of the XPA and lift off the cover. See the following illustration.

**CAUTION** *Electrostatic discharge (ESD) can damage IC chips even though you cannot feel it. You must be electrically grounded before touching anything inside the XPA. A grounding wrist strap is recommended.*

## Installation, cont'd

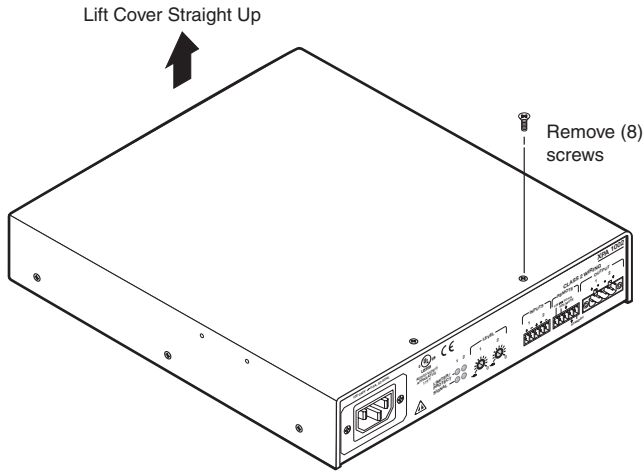

3. Remove the 2 screws holding the **hot** (line) and **neutral** wires from the terminal block on the PCB.

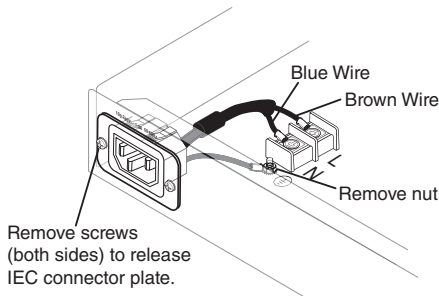

4. Remove the ground wire nut from the grounding stud on the bottom of the enclosure, as shown above.
5. Remove the 2 screws from the IEC plate, and remove the IEC connector plate and the attached wires through the rear panel of the XPA, as shown above.
6. Thread the 18-gauge power wires through the length of the electrical conduit tube.
7. Install the EMT adapter plate with conduit attached into the opening from which the IEC connector was removed, in step 5.
8. Slide the conduit nut over the bundle of wires exiting the conduit and onto the conduit itself. Hand tighten the conduit nut to the conduit.
9. Attach the EMT adapter plate assembly to the XPA using the 2 screws that were removed in step 5.

10. Connect the black **hot** (line) and white **neutral** wires to the terminal block on the PCB using the 2 screws that were removed in step 3. Use the included zip tie wrap to secure the two wires together close to the terminals. See the following illustration.

**WARNING** *Ensure that you observe correct wire polarity. The following illustration shows the location of the hot (L) and neutral (N) terminals.*

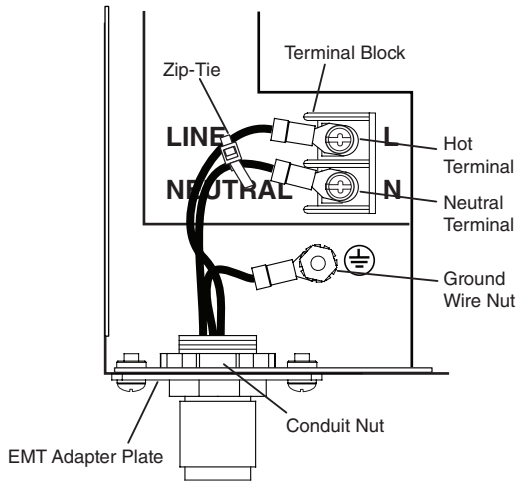

11. Connect the ground wire, as shown above, to the grounding stud on the bottom of the enclosure using the nut that was removed in step 4.
12. Replace the cover of the XPA by attaching the 8 screws that were removed in step 2.





**XTRA Series**

# 3

## **Chapter Three**

### **Operation**

Front Panel Features and Operation

Rear Panel Features and Operation

# Operation

## Front Panel Features and Operation

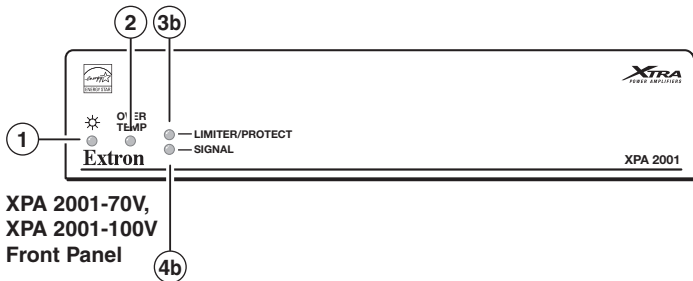
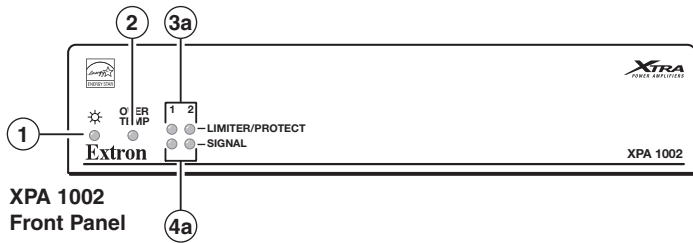

- ① **Power indicator LED** — This LED lights:
- Green when the amplifier is receiving full power.
  - Amber when the amplifier is in Standby mode. Standby mode turns off all outputs from the amplifier, although the amplifier is still receiving power.
- See ⑥ of “Rear Panel Features and Operation” in this chapter.

- ② **Over Temp indicator LED** — This LED lights red when the amplifier exceeds the recommended ambient temperature for optimal lifetime. The LED will turn off after the amplifier has cooled down sufficiently.

Should the LED light, check the following:

- Verify that the placement of the amplifier allows for adequate ventilation and airflow.
- Avoid placing other equipment on top of the amplifier.
- Verify that the operating temperature is within the specified range.

- ③a **Limiter/Protect indicator LEDs (channels 1 and 2)** — These LEDs (representing output channels 1 and 2) light red under four circumstances:

---

1 2  
 — **LIMITER/PROTECT**

- When the output wiring is shorted together
- When audio clipping occurs, the corresponding channel's LED blinks once per clip occurrence.
- When the amplifier overheats, both LEDs are lit. The LEDs are not lit after the amplifier recovers from the overheated condition.
- When DC output is detected, the amplifier is malfunctioning and the LED for the corresponding channel is lit. The amplifier requires servicing when this event occurs.

**NOTE** *These LEDs are also located on the rear panel.*

**3b** **Limiters/Protect indicator LED** — This LED (representing the output channel) lights red under four circumstances:

- When the output wiring is shorted together
- When audio clipping occurs, the LED blinks once per clip occurrence.
- When the amplifier overheats, the LED is lit. The LED is not lit after the amplifier recovers from the overheated condition.
- When DC output is detected, the amplifier is malfunctioning and the LED is lit. The amplifier requires servicing when this event occurs.

**NOTE** *This LED is also located on the rear panel.*

**4a** **Signal indicator LEDs (channels 1 and 2)** — These LEDs (representing input channels 1 and 2) light green only when an input signal is detected on the corresponding channel.

1 2  
 — **SIGNAL**

**NOTE** *These LEDs are also located on the rear panel.*

**4b** **Signal indicator LED** — This LED (representing the input channel) lights green only when an input signal is detected.

**NOTE** *This LED is also located on the rear panel.*

## Rear Panel Features and Operation

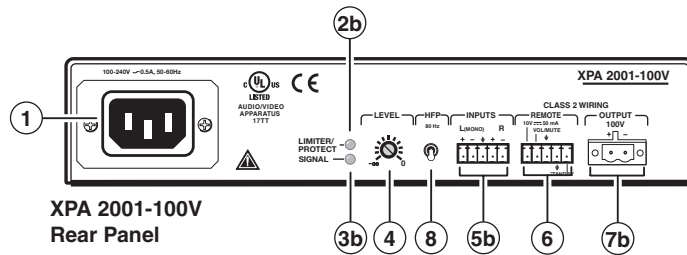
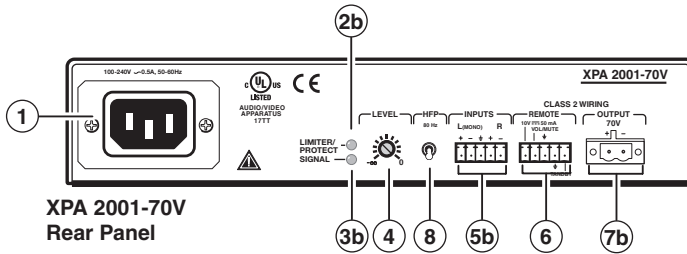
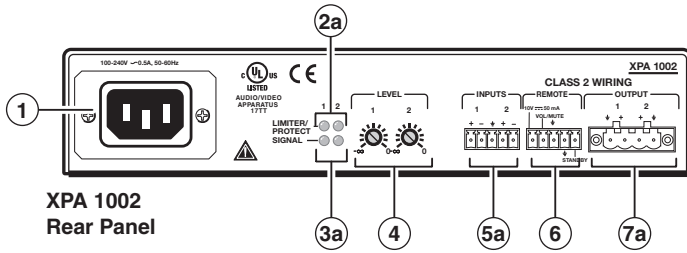

- ① **AC power connector** — Connect a standard IEC AC power cord here for power input (100 VAC to 240 VAC, 50/60 Hz) to the internal, autoswitching power supply. This connector may be replaced by the PS 123 Flexible Conduit Adapter Kit (part #70-228-02) as described in "Flexible conduit adapter kit installation" in chapter 2.
- ②a **Limiter/Protect indicator LEDs (channels 1 and 2)** — These LEDs (representing output channels 1 and 2) light red under four circumstances:



- When the output wiring is shorted together
- When audio clipping occurs, the corresponding channel's



---

LED blinks once per clip occurrence.

- When the amplifier overheats, both LEDs are lit. The LEDs are not lit after the amplifier cools down and recovers from the overheated condition.
- When DC output is detected, the amplifier is malfunctioning and the LED for the corresponding channel is lit. When a malfunction occurs, power down the amplifier and power it back up. If the LED still remains lit, the amplifier requires servicing.

See step 3a of "Front Panel Features and Operation" in this chapter.

**2b) Limiter/Protect indicator LED** — This LED (representing the output channel) lights red under four circumstances:

- When the output wiring is shorted together
- When audio clipping occurs, the LED blinks once per clip occurrence.
- When the amplifier overheats, the LED is lit. The LED is not lit after the amplifier cools down and recovers from the overheated condition.
- When DC output is detected, the amplifier is malfunctioning and the LED is lit. When a malfunction occurs, power down the amplifier and power it back up. If the LED still remains lit, the amplifier requires servicing.

See step 3b of "Front Panel Features and Operation" in this chapter.

**3a) Signal indicator LEDs (channels 1 and 2)** — These LEDs (representing input channels 1 and 2) light green only when an input signal is detected on the corresponding channel.

1 2



See step 4a of "Front Panel Features and Operation" in this chapter.

**3b) Signal indicator LED** — This LED (representing the input channel) lights green only when an input signal is detected.

**4) Level adjustment (channels 1 and 2)** — Use a small screwdriver to adjust the audio input level for the corresponding channel. The analog potentiometers control the level from  $-\infty$  (full attenuation) to 0 dB.

## Operation, cont'd

**NOTE** *On the XPA 2001, the single control adjusts the levels of both channels simultaneously prior to summing them together.*

To adjust the XPA amplifier's input level, do the following:

1. If connecting to a source device with a volume control (variable output), ensure that the volume on the source device is set to its lowest point, then adjust the level(s) of the XPA fully counterclockwise.
2. Set the source device's volume to its maximum volume level. No sound should come out.
3. Return to the XPA amplifier and raise the level(s) until sound distortion occurs, then lower the level(s) slightly until any distortion disappears. This setting ensures that, whatever the source device volume setting may be, no clipping occurs.

**NOTE** *When setting volume control through a source device, ensure that the device's volume is set to **variable out**. Consult the device's user manual for detailed instructions on its calibration.*

- 5a** **Balanced or unbalanced stereo audio input connector** — Wire the 3.5 mm 5-pin captive screw connector for balanced or unbalanced input.

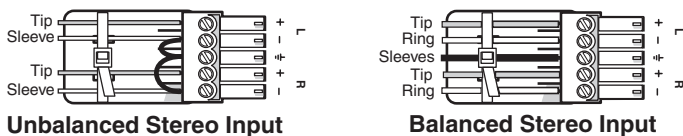

**Do not tin the wires!**

**NOTE** *The XPA 1002's output power can be effectively doubled by using only one input channel and bridging the output. The XPA 1002 will output 200 watts @ 8 ohms or 120 watts @ 16 ohms in bridged mode. See "Bridged mono output" in this chapter for wiring instructions when bridging the XPA 1002.*

- 5b** **Balanced or unbalanced mono audio input connector** — Wire the 3.5 mm 5-pin captive screw connector for balanced or unbalanced input.

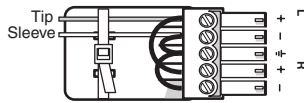

**Unbalanced Mono Input**

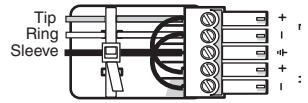

**Balanced Mono Input**  
(high impedance)



**Do not tin the wires!**

**NOTE** For mono input on the XPA 2001, only the left channel needs to be wired. No jumpering to the right channel is needed.

⑥ **Remote control connector** — The 3.5 mm 5-pin captive screw receptacle is used to remotely control two functions through contact closure: See the following circuit diagram.

- Pins 1, 2, and 3 control volume by varying the DC voltage from 0 V (full attenuation) to 10 V (maximum volume) with full muting in effect when pin 2 is connected to ground (pin3). Use the included 3-pin captive screw connector. See "Remote volume control" in this chapter.

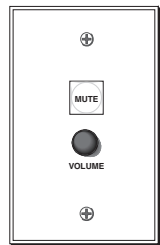
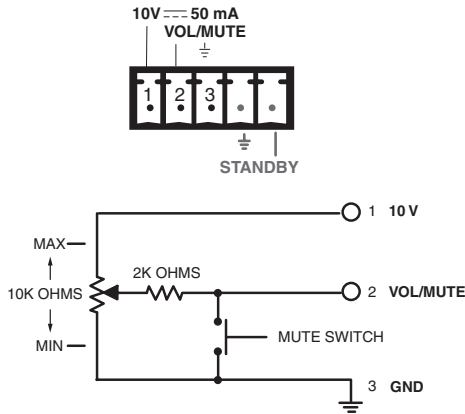

## Operation, cont'd

- Pin 5 connected to ground (pin 4) places the amplifier in standby mode. Standby mode turns off all output, although the amplifier is still receiving power. Use the included 2-pin, 3.5 mm captive screw connector to remotely ground pin 5. The power indicator LED lights amber when the amplifier is in standby mode.

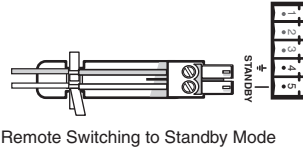
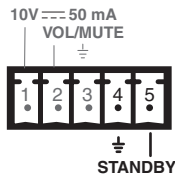

- 7a** **Stereo audio output connector (channels 1 and 2)** — Marked "1" and "2" for the output channels, wire the included 4-pole, 5 mm screw lock captive screw connector to output stereo audio through either channel. Observe the correct polarities for each channel. Output is designed to power 4 or 8 ohm speakers and is rated at 50 watts per channel.

**NOTE** You must use Class 2 wiring for this output to comply with UL requirements.

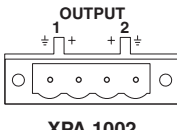

**WARNING** Do not tie channel outputs 1 and 2 to each other or to ground. Doing so will short out the outputs and/or damage the amplifier.

**NOTE** The XPA 1002's output power can be effectively doubled by using only one input channel and bridging the output. The XPA 1002 will output 200 watts at 8 ohms or 120 watts at 16 ohms in bridged mode. See "Bridged mono output" in this chapter for wiring instructions when bridging the XPA 1002.

---

**Step 1:** Strip and insert the speaker wires into the connector and tighten the captive screws. Be sure to observe the correct polarity.

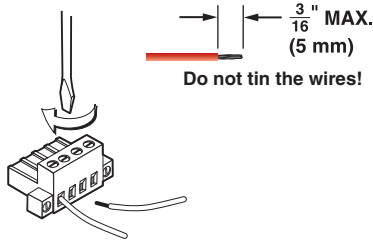

**Step 2:** Insert the wired connector into the amplifier output and secure the locking screws on either side.

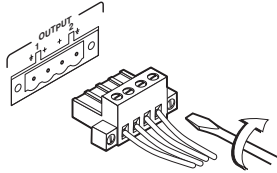

- 7b** **Mono audio output connector** — Marked "+" and "-", wire the included 2-pole, 5 mm screw lock captive screw connector for mono audio. See the following steps on the next page. Output is designed to power 70 V (XPA 2001-70V) or 100 V (XPA 2001-100V) line distribution systems and is rated at 100 watts.

**NOTE** You must use Class 2 wiring for this output to comply with UL requirements.

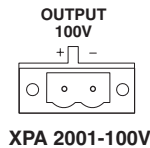
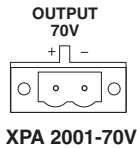

**WARNING** Do not short out the "+" and "-" connectors with each other; doing so will damage the amplifier.

## Operation, cont'd

---

**Step 1:** Strip and insert the speaker wires into the connector and tighten the captive screws. Be sure to observe the correct polarity.

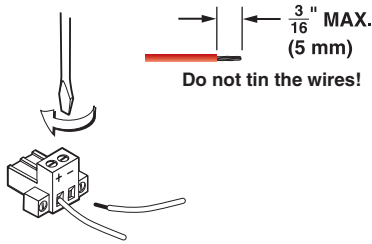

**Step 2:** Insert the wired connector into the amplifier output and secure the locking screws on either side.

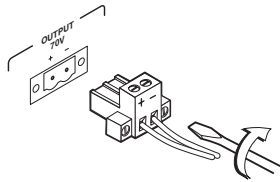

- ⑧ **High pass filter toggle switch** — Use a small screwdriver to toggle this recessed two-position toggle switch that alternates between Off and 80 Hz. Setting the switch to 80 Hz prevents the saturation of 70 V/100 V speaker input transformers by low frequency signals. Saturation may result in undesired overheating of the speaker transformers.

**NOTE** *Filtering may be unnecessary if filtering is applied to the source input signal upstream of the amplifier.*

---

## Remote volume control

Options for remote control of the XPA amplifiers include the Extron VCM 100 and VC 50 volume controllers. Third party 10k potentiometer volume controllers can also be connected to this port.

As shown in the following illustration, the XPA's pin 1 is 10 VDC reference voltage. Pin 2 is volume control DC voltage, range is 0 to 10 V, where 0 V is mute and 10 V provides maximum volume. Pin 3 is ground.

**NOTE** All nominal levels are at  $\pm 10\%$ .

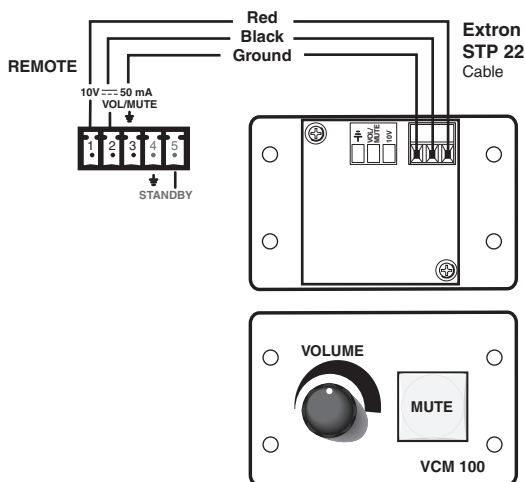

**Pinout diagram for VCM 100 MAAP connection to XPA's remote connector**

## Bridged mono output

The power output of the XPA 1002 can be effectively doubled by bridging the output. Bridging allows power to be output in mono at 200 watts @ 8 ohms or 120 watts @ 16 ohms.

**NOTE** The bridging instructions that follow apply only to the XPA 1002 model.

**NOTE** The minimum load impedance when bridging is 8 ohms.

To bridge the output, follow the steps and refer to the diagram below:

1. Unplug the IEC power cord from the power amplifier.
2. Wire the output as shown in the following diagram.

## Operation, cont'd

3. Wire the input as shown in the following diagram.
4. Connect the IEC power cord and power up the amplifier.
5. Adjust the input levels of channels 1 and 2 equally.

Refer to step ④ (level adjustment) of "Rear Panel Features and Operation" in this chapter for more details.

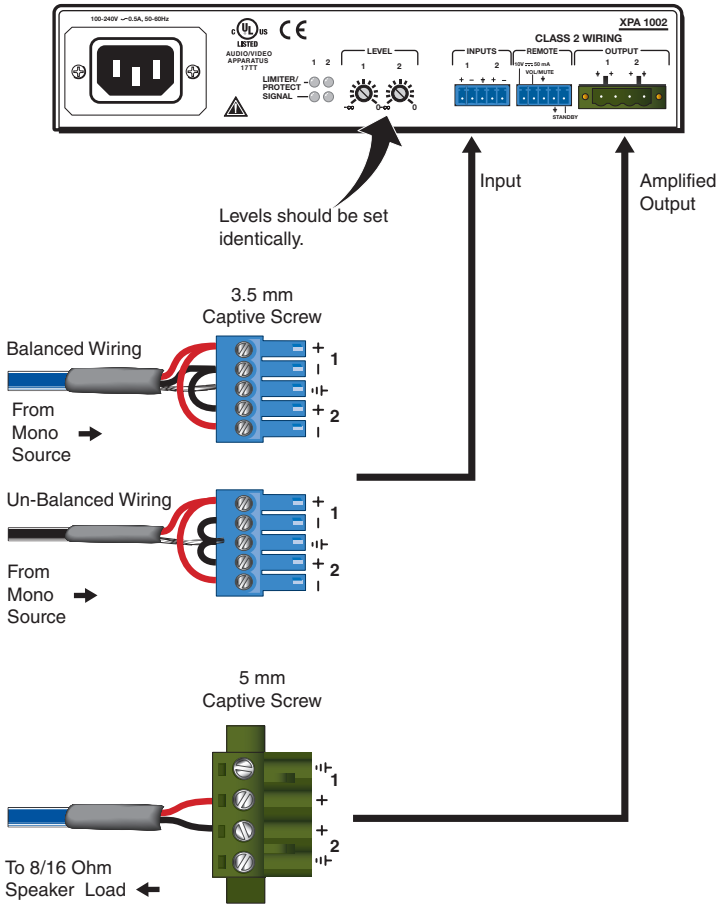





**XTRA Series**

# A

# **Appendix A**

## **Reference**

Specifications

Included Parts

Optional Accessories

# Specifications, Part Numbers, and Accessories

## Specifications

### Audio

#### Voltage gain

XPA 1002.....	16x (24 dB)
XPA 2001-70V.....	57x (35 dB)
XPA 2000-100V.....	81x (38 dB)

Stereo channel separation..... >75 dB @ 1 kHz

CMRR..... 75 dB @ 1 kHz (typical)

### Audio input

Number/signal type..... 1 stereo or 2 mono, balanced/unbalanced

Connectors..... (1) 3.5 mm captive screw connector, 5 pole

Impedance..... >10k ohms unbalanced/balanced, DC coupled

Nominal level..... +4 dBu (1.23 Vrms), balanced

Maximum level..... +20 dBu (7.75 Vrms), balanced

#### Input sensitivity

XPA 1002..... +4 dBu (1.23 Vrms)

XPA 2001-70V, XPA 2001-100V  
+4 dBu (1.23 Vrms) if driven by one input  
-2 dBu (0.615 Vrms) if both inputs are summed

**NOTE**  $0\text{ dBu} = 0.775\text{ Vrms}$ ,  $0\text{ dBV} = 1\text{ Vrms}$ ,  $0\text{ dBV} \approx 2\text{ dBu}$

### Audio output

#### Number/signal type

XPA 1002..... 1 stereo, 4- or 8-ohm direct

XPA 2001-70V..... 1 mono, 70 V line

XPA 2001-100V..... 1 mono, 100 V line

#### Connectors

XPA 1002..... (1) 5 mm screw lock captive screw connector, 4 pole

XPA 2001-70V, XPA 2001-100V  
(1) 5 mm screw lock captive screw connector, 2 pole

**NOTE** *These connectors accept wires of 22 AWG to 12 AWG.*

#### Load impedance

XPA 1002..... 4 ohms minimum

XPA 2001-70V..... 25 ohms minimum

XPA 2001-100V..... 50 ohms minimum

Amplifier type..... Class D

---

Output power	
XPA 1002 .....	60 watts rms per channel, 8 ohms, 1 kHz, <0.05% THD 100 watts rms per channel, 4 ohms, 1 kHz, <0.05% THD
XPA 2001-70V .....	200 watts rms, 70 V, 1 kHz, <0.1% THD
XPA 2001-100V .....	200 watts rms, 100 V, 1 kHz, <0.1% THD
Frequency response .....	20 Hz to 20 kHz, $\pm 1$ dB
THD + Noise	
XPA 1002 .....	0.05% @ 20 Hz-20 kHz, 8 ohms, at 3 dB below clipping
XPA 2001-70V, XPA 2001-100V	<0.1% @ 1 kHz at 3 dB below clipping
S/N	
XPA 1002 .....	105 dB, 20 Hz - 20 kHz, unweighted
XPA 2001-70V, XPA 2001-100V	100 dB, 20 Hz - 20 kHz, unweighted
Damping factor	
XPA 1002 .....	>100 @ 8 ohms
XPA 2001-70V .....	>100 @ 25 ohms
XPA 2001-100V .....	>100 @ 50 ohms
High pass filter	
XPA 2001-70V, XPA 2001-100V	80 Hz, 12 dB per octave rolloff (switch selectable)

## Control/remote — amplifier

Control port.....	(1) 3.5 mm captive screw connector, 5 pole
Pin configurations	
DC volume control (analog)	Pin 1 = +10 VDC, 50 mA (max.), pin 2 = volume/mute (variable voltage), pin 3 = GND
Volume control voltage range	0 V (mute) to 10 V (maximum volume)
Standby power control (contact closure)	Pin 4 = GND, pin 5 = standby

## General

Power .....	100 VAC to 240 VAC, 50-60 Hz, internal
Typical.....	26 watts (1/8 power [pink noise] at 8 ohms)
Quiescent	

# Specifications, Part Numbers, Accessories, cont'd

---

XPA 1002, XPA 2001-70V	10 watts
XPA 2001-100V .....	12 watts
Standby .....	<1 watt (triggered by contact closure or after 1 hour with no signal)
Temperature/humidity .....	Storage: -40 to +158 °F (-40 to +70 °C) / 10% to 90%, noncondensing Operating: +32 to +122 °F (0 to +50 °C) / 10% to 90%, noncondensing
Cooling .....	Convection, no vents, with internal heat sinks
Thermal dissipation	
Standby .....	<1 watt (3 BTU/hr)
Idle.....	10 watts (34 BTU/hr)
1/8 power (pink noise).....	4 ohms (x2): 14 watts (48 BTU/hr) 8 ohms (x2): 14 watts (48 BTU/hr) 70 V (XPA 2001-70V): 14 watts (48 BTU/hr)
Protection .....	Clip limiting, thermal, short circuit, DC output
Indication.....	Limiter/Protect LED indicates the onset of clip limiting, thermal cycling, short circuit, or DC output protection
Mounting	
Rack mount .....	Yes, with optional 1U rack shelf
Enclosure type .....	Metal
Enclosure dimensions.....	1.7" H x 8.7" W x 9.5" D (1U high, half rack wide) (4.3 cm H x 22.1 cm W x 24.1 cm D)
Product weight .....	2.5 lbs (1.1 kg)
Shipping weight .....	5 lbs (3 kg)
Vibration.....	ISTA 1A in carton (International Safe Transit Association)
Regulatory compliance	
Safety.....	CE, c-UL, UL UL rated for use in plenum airspaces: meets UL 2043 for heat and smoke release; meets UL 60065, IEC 60065, and BSEN 60065 for A/V equipment.
EMI/EMC .....	CE, CISPR 22 Class B, C-tick, FCC Class B, ICES, VCCI Class B

Environmental .....	Complies with the appropriate requirements of CEC, ENERGY STAR® (ENERGY STAR® qualified amplifier), EU code of conduct, RoHS, WEEE
MTBF.....	250,000 hours
Warranty.....	3 years parts and labor

**NOTE** All nominal levels are at  $\pm 10\%$ .

**NOTE** Specifications are subject to change without notice.

## Included Parts

These items are included in each order of the XPA 1002 or XPA 2001-70V.

Included parts	Replacement part number
XPA 1002 two-channel power amplifier <i>or</i>	60-849-01
XPA 2001-70V single-channel power amplifier <i>or</i>	60-850-01
XPA 2001-100V single-channel power amplifier	60-850-11
(1) 4-pole screw lock 5.08 mm captive screw plug (XPA 1002)	10-760-10LF
(1) 2-pole screw lock 5.08 mm captive screw plug (XPA 2001-70V/100V)	10-760-11LF
(1) 5-pole 3.5 mm captive screw plug	10-703-12LF
(1) 3-pole 3.5 mm captive screw plug	10-703-11LF
(1) 2-pole 3.5 mm captive screw plug	10-703-10LF
(4) rubber feet (detached)	
IEC power cord	
User's manual	

## Specifications, Part Numbers, Accessories, cont'd

---

### Optional Accessories

<b>Accessory</b>	<b>Part number</b>
RSU 129 9.5" deep 1U universal rack shelf kit	60-190-01
RSB 129 9.5" deep 1U basic rack shelf	60-604-01
VCM 100 AAP volume and mute control	70-396-11, -21, -51
VCM 100 MAAP volume and mute control	70-397-11, -21, -51
VC 50 volume control wall plate	70-530-02
Flexible conduit adapter kit	70-228-02

# Extron Warranty

Extron Electronics warrants this product against defects in materials and workmanship for a period of three years from the date of purchase. In the event of malfunction during the warranty period attributable directly to faulty workmanship and/or materials, Extron Electronics will, at its option, repair or replace said products or components, to whatever extent it shall deem necessary to restore said product to proper operating condition, provided that it is returned within the warranty period, with proof of purchase and description of malfunction to:

**USA, Canada, South America,  
and Central America:**

Extron Electronics  
1001 East Ball Road  
Anaheim, CA 92805, USA

**Europe, Africa, and the Middle East:**

Extron Electronics, Europe  
Beeldschermweg 6C  
3821 AH Amersfoort  
The Netherlands

**Asia:**

Extron Electronics, Asia  
135 Joo Seng Road, #04-01  
PM Industrial Bldg.  
Singapore 368363

**Japan:**

Extron Electronics, Japan  
Kyodo Building  
16 Ichibancho  
Chiyoda-ku, Tokyo 102-0082  
Japan

This Limited Warranty does not apply if the fault has been caused by misuse, improper handling care, electrical or mechanical abuse, abnormal operating conditions or non-Extron authorized modification to the product.

*If it has been determined that the product is defective, please call Extron and ask for an Applications Engineer at (714) 491-1500 (USA), 31.33.453.4040 (Europe), 65.6383.4400 (Asia), or 81.3.3511.7655 (Japan) to receive an RA# (Return Authorization number). This will begin the repair process as quickly as possible.*

Units must be returned insured, with shipping charges prepaid. If not insured, you assume the risk of loss or damage during shipment. Returned units must include the serial number and a description of the problem, as well as the name of the person to contact in case there are any questions.

Extron Electronics makes no further warranties either expressed or implied with respect to the product and its quality, performance, merchantability, or fitness for any particular use. In no event will Extron Electronics be liable for direct, indirect, or consequential damages resulting from any defect in this product even if Extron Electronics has been advised of such damage.

Please note that laws vary from state to state and country to country, and that some provisions of this warranty may not apply to you.

**Extron USA - West**  
Headquarters

**+800.633.9876**  
*Inside USA / Canada Only*  
**+1.714.491.1500**  
**+1.714.491.1517 FAX**

**Extron USA - East**

**+800.633.9876**  
*Inside USA / Canada Only*  
**+1.919.863.1794**  
**+1.919.863.1797 FAX**

**Extron Europe**

**+800.3987.6673**  
*Inside Europe Only*  
**+31.33.453.4040**  
**+31.33.453.4050 FAX**

**Extron Asia**

**+800.7339.8766**  
*Inside Asia Only*  
**+65.6383.4400**  
**+65.6383.4664 FAX**

**Extron Japan**

**+81.3.3511.7655**  
**+81.3.3511.7656 FAX**

**Extron China**

**+400.883.1568**  
*Inside China Only*  
**+86.21.3760.1568**  
**+86.21.3760.1566 FAX**

**Extron Middle East**

**+971.4.2991800**  
**+971.4.2991880 FAX**