

**MEGAZIP-PLUS ROUND** #S.55 \_\_\_\_\_ - \_\_\_\_\_ - \_\_\_\_\_  
**DOWNLIGHT Ø11"** MODEL VOLTAGE FINISH

MEGAZIP-PLUS is a recessed downlight luminaire. It is fixed to the false ceiling by a heavy-duty bracket system. It conforms to all ceiling thickness' using fasteners located on the outer trim.

**LAMPING:** 1 X 70W T6 METAL HALIDE,  
G12 BASE

**PROJECT NAME:** \_\_\_\_\_

**TYPE:** \_\_\_\_\_ **QTY:** \_\_\_\_\_

LAST UPDATE: SEPTEMBER 06, 2012

**ALUMINUM FRONT RING (14° BEAM)**

**STAINLESS STEEL FRONT RING (20° BEAM)**

**SEMI-ACID  
ETCHED GLASS**



○ **S.5568-XXX-14**



○ **S.5578-XXX-19**

POWER CABLE  
(3" LENGTH)

DOUBLE CABLE ENTRY  
W/ CABLE GLAND

1 X 70W T6 METAL HALIDE  
**(NOT INCLUDED)**  
W/ ADJUSTABLE ±15°  
OPTIC

MOUNTING SCREW  
(X2, TYP.)

REFLECTOR

FASTENING  
BRACKET

DIE-CAST ALUMINUM  
HOUSING, POWDER  
PAINTED FOR HIGH  
CORROSION RESISTANCE

CEILING

SQ.6"  
(153mm)

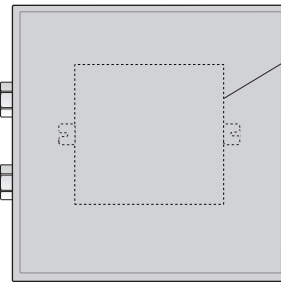

**REMOTE ELECTRONIC  
BALLAST WITH ALUMINUM  
BOX (IP65), (6" SQ. X 4" H)**

8-1/2"  
(216mm)

**SECTION VIEW**

1/4" TO 1-1/8"  
MATERIAL

ALUMINUM OR  
STAINLESS STEEL  
FRONT RING

SEMI ACID ETCHED  
GLASS, 1/2" (12mm) THICK.

STAINLESS STEEL  
FASTENERS

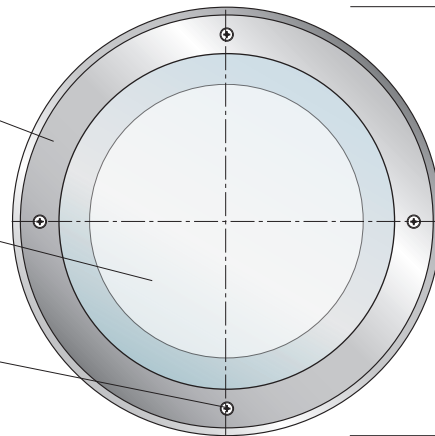

**BOTTOM VIEW**

Ø11"  
(280mm)



**CUT-OUT**  
MINIMUM 10-1/16" (255mm)  
MAXIMUM 10-1/8" (257mm)

**WEIGHT:**  
**5,96KG. (13,14LBS.)**  
**FOR S.5568**

**WEIGHT:**  
**6,19KG. (13,65LBS.)**  
**FOR S.5578**

**VOLTAGE**

○ 120V ○ 277V

**IP 65**

**IK 09**



5455 de Gaspé  
suite 100, Montréal (Québec)  
Canada H2T 3B3  
P.: 514.523.1339 F.: 514.525.6107

**SISTEMALUX**  
GROUP

**MEGAZIP-PLUS ROUND**  
**DOWNLIGHT Ø11"**