

NEW!

DK884X FL

LEARN EVERY FACET OF OPERATION AND DESIGN

Electric Relays

PRINCIPLES AND APPLICATIONS

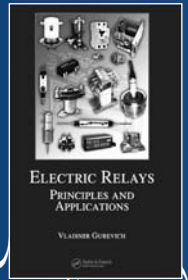

Vladimir Gurevich
Israel Electric Corporation, Haifa

A volume in the series *Electrical and Computer Engineering*
Series edited by Ashwani K. Gupta, University of Maryland, College Park, USA
David G. Lilley, Oklahoma State University, Stillwater, USA

The First Illustrated "Encyclopedia" of Electric Relays

Electric relays pervade the electronics that dominate our world. They exist in many forms, fulfill many roles, and each have their own behavioral nuances and peculiarities. To date, there exists no comprehensive reference surveying the broad spectrum of electric relays, save one—**Electric Relays: Principles and Applications**. This ambitious work is not only unique in its scope, but also in its practical approach that focuses on the operational and functional aspects rather than on theory and mathematics.

Accomplished engineer Dr. Vladimir Gurevich builds the presentation from first principles, unfolding the concepts and constructions via discussion of their historical development from the earliest ideas to modern technologies. He uses a show-not-tell approach that employs nearly 1300 illustrations and reveals valuable insight based on his extensive experience in the field. The book begins with the basic principles of relay construction and the major functional parts, such as contact and magnetic systems. Then, it devotes individual chapters to the various types of relays. The author describes the principles of function and construction for each type as well as features of several relays belonging to a type that operate on different principles.

Remarkably thorough and uniquely practical, **Electric Relays: Principles and Applications** serves as the perfect introduction to the plethora of electric relays and offers a quick-reference guide for the experienced engineer.

FEATURES

- Provides a comprehensive survey of the entire range of electric relays with a focus on the practical aspects
- Develops a deep understanding of the design, operation, and applications of relays and their major components
- Covers the entire "world of electrical relays," from reed switch, solid-state, and high-voltage relays to distance, frequency, and microprocessor-based relays
- Includes abundant illustrations, references, and a complete glossary of terms

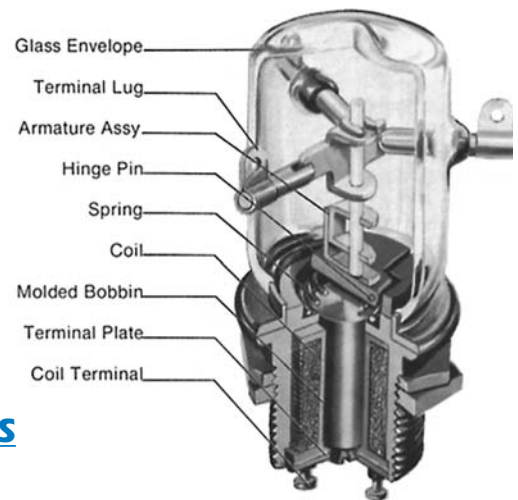

CONTENTS

HISTORY

Relays and Horses
From Oersted to Henry
Art Professor Samuel Morse
Edison's Relay
The First Industrial Relays in
Russia

MAGNETIC SYSTEMS OF RELAYS

Basic Components of an
Electromagnetic Relay
Hysteresis and Coercitive Force
Types of Magnetic Systems
Differences Between AC and
DC Relays
Some Auxiliary Elements
Improving the Relay
Operation
What Happens When a Relay is
Energized
Windings of Relays: Types and
Design Features

CONTACT SYSTEMS

Designs of Basic Types of
Contacts
Silver, Gold, Platinum
Contacts with Two-Stage
Commutation
What is the Purpose of
"Contact Pressure?"
Self-Cleaning Contacts
Self-Adjusting Contacts
When Power Does Not Equal
Multiplication by Current and
Voltage

Split, Make-Before-Break, High-
Frequency Contacts
Compensation for Shock and
Electro-Dynamic Forces in
Contacts

Sparking Contacts and Their
Control

High-Power Contact Systems
Mercury Displacement Relays

EXTERNAL DESIGN OF RELAYS

Environmental Impact on
Relays
Wood and Cardboard: First
Protection Shield for Relays
Is a Sealed Relay Always Better
Than an Open One?
Outlets, Terminal Sockets and
"Containers" for Relays
Indicators of Operation and
Test Buttons

Relays That Do Not Look Like
Relays at All

REED SWITCHES AND REED RELAYS

Who invented a "Reed Switch"?
Coruscation of Ideas and
Constructions
High-Power Reed Switches
Membrane Reed Switches
Mercury Reed Switches
High-Voltage Reed Switches
Reed Switches with Liquid
Filling

 **CRC Press**
Taylor & Francis Group

Catalog no. DK884X
January 2006, 704 pp.
ISBN: 0-8493-4188-4
\$149.95 / £85.00

See reverse for continuation of contents and ordering information

CONTENTS CONTINUED

Polarized and Memory Reed Switches
 Reed Switch Relays
 Mercury Reed Relays
 Winding-Free Relays
HIGH-VOLTAGE RELAYS
 What is a "High-Voltage Relay?"
 Open Relays for High-Voltage Switching
 Vacuum and Gas-Filled High-Voltage Low Power Relays
 High Power Vacuum Relays and Contactors
 High-Voltage Reed Relays
 High-Voltage Interface Relays
ELECTRONIC RELAYS
 Was It Thomas A. Edison Who Invented a Vacuum Light Lamp?
 Lee De Forest Radio Valve: From Its First Appearance Until Today
 How a Vacuum Tube Works?
 Relays with Vacuum Valves
 Gas-Tubes with Relay Characteristics
 Power Mercury Valves
 Electron-Beam Switching Tubes
 Semiconductor Relays
 Optoelectronic Relays
 Super-Power Electronic Relays
 Hybrid Relays
TIME RELAYS
 Electromagnetic Time Relays
 Capacitor Time Relays
 Relays with Clockwork

Pneumatic and Hydraulic Time-Delay Relays
 Electronic Time-Delay Relays
 Attachments to Standard Electromagnetic Relays
 Microprocessor-Based Time-Delay Relays
 Accelerated (Forced) Relays
THERMAL RELAYS
 Relays Based on a Bimetal Thermal Element
 Protective Thermal Relays
 Automatic Circuit Breakers with Thermal Elements
 Dilatometer Relays
 Manometric Thermal Relays
 Mercury Thermal Relays
 Thermal Relays with Reed Switches
 Semiconductor Thermal Elements and Thermal Relays
PROTECTIVE CURRENT AND VOLTAGE RELAYS
 What are "Protective Relays?"
 Current and Voltage Transformers
 Instantaneous Current and Voltage Relays
 Current Relays with Independent "Time-Delays"
 Current Relays with Dependent Time-Delays
 Harmonic and Voltage Restraint Relays
 Pulse Current Relays

POWER AND POWER DIRECTIONAL RELAYS
 Induction-Type Relays
 Characteristics of Power Direction Relays
 Electro-Dynamic-Type Relays
 Electronic Analogs of Power Direction Relays
DIFFERENTIAL RELAYS
 Principles of Differential Protection
 High-Impedance Differential Relays
 Biased Differential Relays
 Electromagnetic Percentage Differential Relay
 Induction-Type Differential Relays
 Harmonic Restraint Differential Relays
 Pilot-Wire Relays
DISTANCE RELAYS
 Principles and Basic Characteristics of Distance Protection
 System Swing
 Principles of Distance Relays Construction
 Why do Distance Relays Need "Memory?"
 Distance Relays with Higher Performance
 Electronic Analogs of Impedance Relays
FREQUENCY RELAY
 Why is it Necessary to Control Frequency in Electric Networks?

Charles Steinmetz: Inventor of the Frequency Relay
 Induction Frequency Relays
 Resonance Relays
 Electronic Frequency Relays
MICROPROCESSOR-BASED RELAYS: PROSPECTS AND CHALLENGES
 Is It a Relay at All?
 Advantages of Microprocessor-Based "Relays"
 Disadvantages of Microprocessor-Based "Relays"
 Summing Up
SPECIAL RELAYS
 Polarized Relays
 Latching Relays
 Sequence Relays
 Rotary Relays
 Moving-Coil Relays
 Amplifier-Driven Relays
 Magneto-Hydro-Dynamic Relays
 Annunciator Target Relays
 Flashing-Light Relays
 Buchholz Relays
 Safety Relays
 Ground Fault Relays
 Supervision Relays
 Hydraulic-Magnetic Circuit Breakers
BASIC RELAY TERMS AND DEFINITIONS: GLOSSARY REFERENCES INDEX

Please use this ORDER FORM, CALL or ORDER ONLINE at WWW.CRCPRESS.COM

Please indicate quantities next to the title(s) ordered below:

ELECTRIC RELAYS: PRINCIPLES AND APPLICATIONS
Catalog no. DK884X, ISBN: 0-8493-4188-4 at \$149.95 / £85.00 each.

Other titles of interest:

COMPUTATIONAL METHODS FOR ELECTRIC POWER SYSTEMS
Catalog no. 1352, ISBN: 0-8493-1352-X at \$99.95 / £44.99 each.

ELECTRIC ENERGY: AN INTRODUCTION
Catalog no. 3078, ISBN: 0-8493-3078-5 at \$99.95 / £39.99 each.

ELECTRIC POWER DISTRIBUTION RELIABILITY
Catalog no. DK1983, ISBN: 0-8247-0798-2 at \$159.95 / £92.00 each.

Ordering Information: Orders must be prepaid or accompanied by a purchase order. Checks should be made payable to CRC Press. Please add the appropriate shipping and handling charge for each book ordered. All prices are subject to change without notice. If purchasing by credit card please be sure to include the 3 digit security code that appears on the back of your card in the "sec code" field provided below. **U.S./Canada:** All orders must be paid in U.S. dollars. TAX: As required by law, please add applicable state and local taxes on all merchandise delivered to CA, CT, FL, KY, MO, NY, and PA. For Canadian orders, please add GST. We will add tax on all credit card orders. **European Orders:** All orders must be paid in U.K. £. VAT will be added at the rate applicable. **Textbooks:** Special prices for course adopted textbooks may be available for certain titles. To review a book for class adoption, contact our Academic Sales Department or submit your textbook evaluation request online at www.crcpress.com/eval.htm **Satisfaction Guaranteed:** If the book supplied does not meet your expectations, it may be returned to us in a saleable condition within 30 days of receipt for a full refund.

SHIPPING AND HANDLING			
Region	Delivery Time	First Title	Additional Title
USA/Canada	3-5 Days	\$5.99	\$1.99
South America	7-14 Days	\$9.99	\$3.99
Europe	3-5 Days	£2.99	£0.99
Rest of World	7-21 Days	£4.99	£2.99

For priority mail services, please contact your nearest CRC PRESS office.

Visa MasterCard American Express Check Enclosed \$

Sec. Code	Exp. Date	Month	Year
-----------	-----------	-------	------

Signature and Telephone Number required on all orders

Signature..... PO#.....

Telephone.....

If you would like to receive information from us by e-mail, please provide your e-mail address below.

E-Mail Address

Name
please print clearly

Company/Institution.....

Address.....

City State/Province Zip/Postal Code

Country

ORDERING LOCATIONS

<p>In the Americas: CRC PRESS 6000 Broken Sound Parkway, NW, Suite 300 Boca Raton, FL 33487, USA Tel: 1-800-272-7737 Fax: 1-800-374-3401 <i>From Outside the Continental U.S.</i> Tel: 1-561-994-0555 Fax: 1-561-361-6018 e-mail: orders@taylorandfrancis.com</p>	<p>Rest of the World: CRC PRESS / ITPS Cheriton House, North Way Andover, Hants, SP10 5BE, UK Tel (UK): +44 (0) 1264 34 2926 Tel (Int'l): +44 (0) 1264 34 3070 Fax: +44 (0) 1264 34 3005 e-mail: (UK): uk.tandf@thomsonpublishingservices.co.uk (Int'l): international.tandf@thomsonpublishingservices.co.uk</p>
---	--

Corporate Offices

<p>CRC PRESS 6000 Broken Sound Parkway, NW, Suite 300 Boca Raton, FL 33487, USA Tel: 1-800-272-7737 Fax: 1-800-374-3401 <i>From Outside the Continental U.S.</i> Tel: 1-561-994-0555 Fax: 1-561-361-6018 e-mail: orders@taylorandfrancis.com</p>	<p>CRC PRESS UK 24-25 Blades Court, Deodar Road London SW15 2NU, UK Tel: 44 (0) 20 7017 6000 Fax: 44 (0) 20 7017 6747 e-mail: enquiries@crcpress.com</p>
--	--