

# Royal Gazette

Prince Edward Island

Postage paid in cash at First Class Rates

**PUBLISHED BY AUTHORITY**

**VOL. CXXXIII - NO. 17**

**Charlottetown, Prince Edward Island, April 28, 2007**

**CANADA  
PROVINCE OF PRINCE EDWARD ISLAND  
IN THE SUPREME COURT - ESTATES DIVISION**

TAKE NOTICE that all persons indebted to the following estates must make payment to the personal representative of the estates noted below, and that all persons having any demands upon the following estates must present such demands to the representative within six months of the date of the advertisement:

Estate of: Date of the Advertisement	Personal Representative: Executor/Executrix (Ex) Administrator/Administratrix (Ad)	Place of Payment
CARR, Eric Robert New London Queens Co., PE April 28th, 2007 (17-30)*	Betty Evelyn Carr (EX.)	Ramsay & Clark PO Box 96 Summerside, PE
MacDONALD, Mary Gemma Charlottetown Queens Co., PE April 28th, 2007 (17-30)*	Bonnie Gemma Profitt Karen Mary MacDonald (EX.)	Reagh & Reagh 17 West Street Charlottetown, PE
O'BRIEN, Bertha (also known as Bertha Ann O'Brien) Saint Lambert Quebec April 28th, 2007 (17-30)*	Paul Wade (EX.)	Macnutt & Dumont PO Box 965 Charlottetown, PE
COLLICUTT, Elsie B. O'Leary Prince Co., PE April 28th, 2007 (17-30)*	Steven M. Collicutt E. Deborah Praught (AD.)	Key McKnight & Maynard PO Box 1570 Summerside, PE
WINSLOE, Amelia A. Natick, Middlesex County Massachusetts, USA April 28th, 2007 (17-30)*	Alice Rose (AD.)	Law Office of Alfred K. Fraser, QC PO Box 516 Montague, PE
BALL, Eleanor Mill River East	Arthur Clark (EX.)	J. Allan Shaw Law Corporation PO Box 40

*\*Indicates date of first publication in the Royal Gazette.*

This is the **official** version of the Royal Gazette. The electronic version may be viewed at:  
<http://www.gov.pe.ca/royalgazette>

**CANADA  
PROVINCE OF PRINCE EDWARD ISLAND  
IN THE SUPREME COURT - ESTATES DIVISION**

TAKE NOTICE that all persons indebted to the following estates must make payment to the personal representative of the estates noted below, and that all persons having any demands upon the following estates must present such demands to the representative within six months of the date of the advertisement:

Estate of: Date of the Advertisement	Personal Representative: Executor/Executrix (Ex) Administrator/Administratrix (Ad)	Place of Payment
Prince Co., PE April 21st, 2007 (16-29) COURT, Quintin Guilford North Rustico Queens Co., PE April 21st, 2007 (16-29)	Barry Curtis Ian Kurylyk (EX.)	Alberton, PE  McInnes Cooper BDC Place Suite 620, 119 Kent Street Charlottetown, PE
COUSINS, Ellen Louise Clinton Queens Co., PE April 21st, 2007 (16-29)	Winston Cousins William Cousins (EX.)	Robert McNeill 251 Water Street Summerside, PE
MacCORMACK, Emmett Joseph St. Margarets Kings Co., PE April 21st, 2007 (16-29)	Cauline MacCormack (EX.)	Allen J. MacPhee Law Corporation PO Box 238 Souris, PE
MacDONALD, Ian George Grand Tracadie Queens Co., PE April 21st, 2007 (16-29)	Bernadette Campbell Maurice MacDonald (EX.)	Cox & Palmer PO Box 486 Charlottetown, PE
MURPHY, Edna Charlottetown Queens Co., PE April 21st, 2007 (16-29)	Clifford Murphy Norma Jean Murphy (EX.)	Stewart McKelvey Stirling Scales PO Box 2140 Charlottetown, PE
BARLOW, David Bennett Wellington Prince Co., PE April 21st, 2007 (16-29)	Kelly Ann Hughes (AD.)	Carr Stevenson & MacKay PO Box 522 Charlottetown, PE
HASLAM, Heather Anne Kensington Prince Co., PE April 21st, 2007 (16-29)	Clare Haslam Marion Haslam (AD.)	Regena Kaye Russell Law Corp. PO Box 383 O'Leary, PE
TOOLE, Shirley Marie Green Road, Bonshaw Queens Co., PE April 21st, 2007 (16-29)	Michael Toole Valerie Steele (AD.)	Key McKnight & Maynard PO Box 177 O'Leary, PE
COMPTON, James Robert Belle River Queens Co., PE	Lynn MacIntyre (EX.)	Crane & Hornby 20 Water Street Parkway Charlottetown, PE

**CANADA  
PROVINCE OF PRINCE EDWARD ISLAND  
IN THE SUPREME COURT - ESTATES DIVISION**

TAKE NOTICE that all persons indebted to the following estates must make payment to the personal representative of the estates noted below, and that all persons having any demands upon the following estates must present such demands to the representative within six months of the date of the advertisement:

Estate of: Date of the Advertisement	Personal Representative: Executor/Executrix (Ex) Administrator/Administratrix (Ad)	Place of Payment
April 14th, 2007 (15-28)		
FRIZZELL, George Sterling Springfield Wes Prince Co., PE April 14th, 2007 (15-28)	Lorne Luxton (EX.)	Key McKnight & Maynard tPO Box 177 O'Leary, PE
GALLANT, Emmanuel Alyre Miscouche Prince Co., PE April 14th, 2007 (15-28)	Anita Chaisson (EX.)	Key McKnight & Maynard PO Box 1570 Summerside, PE
GLEN, Helen Summerside Prince Co., PE April 14th, 2007 (15-28)	Gerard Moulins (EX.)	Cox & Palmer 82 Summer Street Summerside, PE
McDONALD, Marjorie Lucille Summerside Prince Co., PE April 14th, 2007 (15-28)	Douglas Brian McDonald Joan Diane McDonald (EX.)	McLellan Brennan PO Box 35 Summerside, PE
WEDGE, Emma Jean Summerside Prince Co., PE April 14th, 2007 (15-28)	Jean Ronahan Sandra Power (EX.)	The Law Office of Kathleen Loo Craig PO Box 11 Summerside, PE
WALSH, Donald Frederick Kingston, Cornwall RR#3 Queens Co., PE April 7th, 2007 (14-27)	Carla "Darlene" Walsh (EX.)	Catherine M. Parkman Law Office PO Box 1056 Charlottetown, PE
WEEKS, Boyd Sheldon Fredericton Queens Co., PE April 7th, 2007 (14-27)	Hazel Jean Ripley (EX.)	Macnutt & Dumont PO Box 965 Charlottetown, PE
MARTIN, Edward Deming New Mexico, USA April 7th, 2007 (14-27)	Linda A. Austin (AD.)	Campbell Lea PO Box 429 Charlottetown, PE
BEACH, Arthur Cornwall Queens Co., PE	Catherine Wells (EX.)	Stewart McKelvey Stirling Scales PO Box 2140 Charlottetown, PE

**CANADA  
PROVINCE OF PRINCE EDWARD ISLAND  
IN THE SUPREME COURT - ESTATES DIVISION**

TAKE NOTICE that all persons indebted to the following estates must make payment to the personal representative of the estates noted below, and that all persons having any demands upon the following estates must present such demands to the representative within six months of the date of the advertisement:

Estate of: Date of the Advertisement	Personal Representative: Executor/Executrix (Ex) Administrator/Administratrix (Ad)	Place of Payment
March 31st, 2007 (13-26)		
CAIRNS, Doris Bly Wilmot Valley Prince Co., PE March 31st, 2007 (13-26)	Denton H. Cairns Marion J. Burrows (EX.)	Donald Schurman 155A Arcona Street Summerside, PE
CAMPBELL-MINNS, Philomena (Phyllis) Patricia (Totten) Charlottetown Queens Co., PE March 31st, 2007 (13-26)	George William Minns (EX.)	Reagh & Reagh 17 West Street Charlottetown, PE
FRASER, Eric John Grand Tracadie Queens Co., PE and Northport Prince Co., PE March 31st, 2007 (13-26)	John Clay Fraser (EX.)	McInnes Cooper BDC Place Suite 620, 119 Kent Street Charlottetown
MacDONALD, Floyd H. St. Catherines Kings Co., PE (Formerly of Petawawa, ON) March 31st, 2007 (13-26)	Yvonne MacDonald (EX.)	Allen J. MacPhee Law Corporation PO Box 238 Souris, PE
MacDONALD, Orilla Mae Charlottetown Queens Co., PE March 31st, 2007 (13-26)	James Willard MacDonald (EX.)	Matheson & Murray PO Box 875 Charlottetown, PE
MacKINNON, Leith Elwin Cornwall Queens Co., PE March 31st, 2007 (13-26)	Grace MacKinnon (EX.)	Catherine M. Parkman Law Office PO Box 1056 Charlottetown, PE
PETERS, Alice C. Charlottetown Queens Co., PE March 31st, 2007 (13-26)	Kenneth J. Peters Eileen M. Bishop (EX.)	Campbell Stewart PO Box 485 Charlottetown, PE
PICKETTS, Duncan Cairns Kelvin Grove Prince Co., PE March 31st, 2007 (13-26)	Linda Grace Jenkins Carl Duncan Picketts (EX.)	Ramsay & Clark PO Box 96 Summerside, PE

**CANADA  
PROVINCE OF PRINCE EDWARD ISLAND  
IN THE SUPREME COURT - ESTATES DIVISION**

TAKE NOTICE that all persons indebted to the following estates must make payment to the personal representative of the estates noted below, and that all persons having any demands upon the following estates must present such demands to the representative within six months of the date of the advertisement:

Estate of: Date of the Advertisement	Personal Representative: Executor/Executrix (Ex) Administrator/Administratrix (Ad)	Place of Payment
ROBBINS, Charles Alvin Summerside Prince Co., PE March 31st, 2007 (13-26)	Spurgeon Alvin Robbins (EX.)	Key McKnight & Maynard PO Box 1570 Summerside, PE
ROSSITER, Eileen G. Charlottetown Queens Co., PE March 31st, 2007 (13-26)	Philip E. Rossiter (EX.)	Stewart McKelvey Stirling Scales PO Box 2140 Charlottetown, PE
THIBAULT, Claudette St-Roch-des-Aulnaies Quebec March 31st, 2007 (13-26)	Nathalie Thibault (EX.)	Cox & Palmer 82 Summer Street Summerside, PE
HUBBS, Freda Milton Ontario March 24th, 2007 (12-25)	David Hubbs Wayne Hubbs (EX.)	Carr Stevenson & MacKay PO Box 522 Charlottetown, PE
LAVERS, Margaret Montague (Formerly of Albion, Montague RR#2) Kings Co., PE March 24th, 2007 (12-25)	Raymond Lavers Judy Landrigan (EX.)	McInnes Cooper BDC Place Suite 620, 119 Kent Street Charlottetown, PE
DUNN, Thomas Victor Sturgeon Kings Co., PE March 24th, 2007 (12-25)	Lorraine Praught (AD.)	Law Office of Alfred K. Fraser, QC PO Box 516 Montague, PE
MacKINNON, Lea Hammond Winsloe Queens Co., PE March 24th, 2007 (12-25)	Harold D. MacKinnon Freda L. MacKinnon (AD.)	Robert R. MacArthur PO Box 127 Cornwall, PE
MacNEILL, Elliott MacLaren Charlottetown Queens Co., PE March 24th, 2007 (12-25)	Vera Dewar (AD.)	Cox & Palmer PO Box 486 Charlottetown, PE

**CANADA  
PROVINCE OF PRINCE EDWARD ISLAND  
IN THE SUPREME COURT - ESTATES DIVISION**

TAKE NOTICE that all persons indebted to the following estates must make payment to the personal representative of the estates noted below, and that all persons having any demands upon the following estates must present such demands to the representative within six months of the date of the advertisement:

Estate of: Date of the Advertisement	Personal Representative: Executor/Executrix (Ex) Administrator/Administratrix (Ad)	Place of Payment
ELLIOTT, Margaret Rose Summerside Prince Co., PE March 17th, 2007 (11-24)	Helen Arsenault (EX.)	Key McKnight & Maynard PO Box 177 O'Leary, PE
GENGE, Joan Nina Beaton Kensington Prince Co., PE March 17th, 2007 (11-24)	Joanne Marie Dell Kathy Lynn Tuck (EX.)	Ramsay & Clark PO Box 96 Summerside, PE
KOENIG, Raymond C. (Jr.) Boston, Suffolk Co. Massachusetts, USA March 17th, 2007 (11-24)	Peter J. Leveroni (EX.)	Paul J. D. Mullin, QC 14 Great George Street Charlottetown, PE
MURCHISON, Mary Catherine Victoria British Columbia March 17th, 2007 (11-24)	Walter A. McEwen Myrna McEwen (EX.)	McLellan Brennan PO Box 35 Summerside, PE
O'CONNOR, Francis Leonard Kildare Capes Prince Co., PE March 17th, 2007 (11-24)	Urban Laughlin Mary Laughlin (EX.)	J. Allan Shaw Law Corporation PO Box 40 Alberton, PE
RATTRAY, Ada Charlottetown Queens Co., PE March 17th, 2007 (11-24)	Olman Mellick (EX.)	Birt & McNeill 138 St. Peters Road Charlottetown, PE
SHARPE, Percy E. West Devon Prince Co., PE March 17th, 2007 (11-24)	Eric Cornish (EX.)	J. Allan Shaw Law Corporation PO Box 40 Alberton, PE
STEVENS, Nellie Grimsby Ontario March 17th, 2007 (11-24)	Ann Marie Watson Robert Norman Stevens (EX.)	Allen J. MacPhee Law Corporation PO Box 238 Souris, PE
STEWART, Lea Donald Rosebank Prince Co., PE March 17th, 2007 (11-24)	Donald Stewart (EX.)	J. Allan Shaw Law Corporation PO Box 40 Alberton, PE

**CANADA  
PROVINCE OF PRINCE EDWARD ISLAND  
IN THE SUPREME COURT - ESTATES DIVISION**

TAKE NOTICE that all persons indebted to the following estates must make payment to the personal representative of the estates noted below, and that all persons having any demands upon the following estates must present such demands to the representative within six months of the date of the advertisement:

Estate of: Date of the Advertisement	Personal Representative: Executor/Executrix (Ex) Administrator/Administratrix (Ad)	Place of Payment
PETERS, John (Jackie) Joseph Charlottetown Queens Co., PE March 17th, 2007 (11-24)	Patricia Ann Glover (AD.)	Lyle & McCabe PO Box 300 Summerside, PE
SMITH, Mary Ellen Charlottetown Queens Co., PE March 17th, 2007 (11-24)	Patricia (Gaudet) O'Shea (AD.)	Philip Mullally Law Office PO Box 2560 Charlottetown, PE
ALLAN, Margaret Louise Stanhope Queens Co., PE March 10th, 2007 (10-23)	Gerald Russell Allan (EX.)	McInnes Cooper BDC Place Suite 620, 119 Kent Street Charlottetown, PE
ANDERSON, M. Keir Charlottetown Queens Co., PE March 10th, 2007 (10-23)	Eric Bowlan (EX.)	Crane & Hornby 20 Water Street Parkway Charlottetown, PE
BOWMAN, Albert I. Charlottetown Queens Co., PE March 10th, 2007 (10-23)	Mary C. Anderson Dorothy B. Hughes Sylvia A. Turner (EX.)	Carr Stevenson & MacKay PO Box 522 Charlottetown, PE
HOOPER, Charles Garth Matheson North Milton Charlottetown RR#10 Queens Co., PE March 10th, 2007 (10-23)	David Hooper Robert Hooper (EX.)	McInnes Cooper BDC Place Suite 620, 119 Kent Street Charlottetown, PE
SMITH, Patrick V. Billerica County of Middlesex Massachusetts, USA March 10th, 2007 (10-23)	Marion K. Smith (EX.)	E. W. Scott Dickieson PO Box 1453 Charlottetown, PE
YEO, Wendell William Southwest Lot 16 Prince Co., PE March 10th, 2007 (10-23)	Grace Yeo (EX.)	Cox & Palmer 82 Summer Street Summerside, PE

**CANADA  
PROVINCE OF PRINCE EDWARD ISLAND  
IN THE SUPREME COURT - ESTATES DIVISION**

TAKE NOTICE that all persons indebted to the following estates must make payment to the personal representative of the estates noted below, and that all persons having any demands upon the following estates must present such demands to the representative within six months of the date of the advertisement:

Estate of: Date of the Advertisement	Personal Representative: Executor/Executrix (Ex) Administrator/Administratrix (Ad)	Place of Payment
COFFEY, Mary Joyce Arlington Massachusetts, USA March 10th, 2007 (10-23)	Harold Leo Coffey (AD.)	Campbell Stewart PO Box 485 Charlottetown, PE
WILKIE, Paul Sterling Alberton Prince Co., PE March 10th, 2007 (10-23)	Constance A. Wilkie (AD.)	Cox & Palmer 82 Summer Street Summerside, PE
BAKER, Joyce Granville Summerside Prince Co., PE March 3rd, 2007 (09-22)	Clifford Forbes Baker (EX.)	David R. Hammond, QC 740A Water Street East Summerside, PE
LABRANCHE, Joseph Placide Armand Kensington Prince Co., PE March 3rd, 2007 (09-22)	Jacqueline Lewis (EX.)	Cox & Palmer PO Box 486 Charlottetown, PE
MacPHAIL, Mary Elizabeth Charlottetown Queens Co., PE March 3rd, 2007 (09-22)	Alan H. Walker Mary C. Rogerson (EX.)	Carr Stevenson & MacKay PO Box 522 Charlottetown, PE
WYAND, Irene Dorothy Charlottetown (formerly of Cavendish) Queens Co., PE March 3rd, 2007 (09-22)	Walter Wyand Gwen Wyand (EX.)	Cox & Palmer PO Box 486 Charlottetown, PE
BRAZIL, James William Elliott, also known as Elliott J. W. Brazil Stratford Queens Co., PE February 24th, 2007 (08-21)	Linda Brazil (EX.)	Law Office of Alfred K. Fraser, QC PO Box 516 Montague, PE
MacLEAN, Alda Eileen Springbrook Queens Co., PE February 24th, 2007 (08-21)	Walter MacLean (EX.)	Donald Schurman 155A Arcona Street Summerside, PE



**CANADA  
PROVINCE OF PRINCE EDWARD ISLAND  
IN THE SUPREME COURT - ESTATES DIVISION**

TAKE NOTICE that all persons indebted to the following estates must make payment to the personal representative of the estates noted below, and that all persons having any demands upon the following estates must present such demands to the representative within six months of the date of the advertisement:

Estate of: Date of the Advertisement	Personal Representative: Executor/Executrix (Ex) Administrator/Administratrix (Ad)	Place of Payment
MYERS, Colin Alvin Hazelbrook Charlottetown RR#1 Queens Co., PE February 24th, 2007 (08-21)	Alma Jenkins Hazel Pippy (EX.)	McInnes Cooper BDC Place Suite 620, 119 Kent Street Charlottetown, PE
PERRY, George Joseph St. Edwards Prince Co., PE February 24th, 2007 (08-21)	Amy Graham (EX.)	J. Allan Shaw Law Corporation PO Box 40 Alberton, PE
BELL, Clayton James Abney Kings Co., PE February 24th, 2007 (08-21)	Jerry Bell (AD.)	Law Office of Alfred K. Fraser, QC PO Box 516 Montague, PE
DIXON, Vance Bulman Albany RR#2 Prince Co., PE February 17th, 2007 (07-20)	Eric R. Dixon Carl H. Dixon (EX.)	McLellan Brennan PO Box 35 Summerside, PE
KING, Sadie Elizabeth Montague Kings Co., PE February 17th, 2007 (07-20)	Sheila Bullock (EX.)	Law Office of Alfred K. Fraser, QC PO Box 516 Montague, PE
MacDONALD, John Wilfred Stratford Queens Co., PE February 17th, 2007 (07-20)	Judith Ann MacDonald Benjamin B. Taylor (EX.)	Judith Ann MacDonald 45 Earl Drive Stratford, PE
MacNEILL, Lloyd Charles Charlottetown Queens Co., PE February 17th, 2007 (07-20)	Sandra Crabbe Eldon Acorn (EX.)	Campbell Stewart PO Box 485 Charlottetown, PE
MATTHEWS, Shirley Elmsdale Prince Co., PE February 17th, 2007 (07-20)	Charlene Costain Vicky Gallant (EX.)	Regena Kaye Russell Law Corp. PO Box 383 O'Leary, PE
McQUAID, Mary C. Stratford Queens Co., PE February 17th, 2007 (07-20)	Mary Elizabeth MacMillan James Michael McQuaid (EX.)	McInnes Cooper BDC Place Suite 620, 119 Kent Street Charlottetown, PE

**CANADA  
PROVINCE OF PRINCE EDWARD ISLAND  
IN THE SUPREME COURT - ESTATES DIVISION**

TAKE NOTICE that all persons indebted to the following estates must make payment to the personal representative of the estates noted below, and that all persons having any demands upon the following estates must present such demands to the representative within six months of the date of the advertisement:

Estate of: Date of the Advertisement	Personal Representative: Executor/Executrix (Ex) Administrator/Administratrix (Ad)	Place of Payment
READ, David Richard Charlottetown Queens Co., PE February 17th, 2007 (07-20)	Elizabeth (Betty) Mae Read (EX.)	Carr Stevenson & MacKay PO Box 522 Charlottetown, PE
VANDERKAAY, Gerrit Jan Alexandra Queens Co., PE February 17th, 2007 (07-20)	Manna Maria Sentner Hannie Gerrit VanderKaay (EX.)	Manna Maria Sentner 1610 Pownal Road Alexandra, PE
VINCENT, Muriel Helena O'Leary Prince Co., PE February 17th, 2007 (07-20)	Shirley Fillmore (EX.)	Ramsay & Clark PO Box 96 Summerside, PE
FARRELL, Terrance B. St. Marys Road Sturgeon Kings Co., PE February 17th, 2007 (07-20)	Gregory Farrell Richard Farrell (AD.)	Carr Stevenson & MacKay PO Box 522 Charlottetown, PE
HUGHES, Owen Everett Scotchford Queens Co., PE February 17th, 2007 (07-20)	Michael A. Farmer, QC (AD.)	Carr Stevenson & MacKay PO Box 552 Charlottetown, PE
MATTHEWS, Erskine Elmsdale Prince Co., PE February 17th, 2007 (07-20)	Charlene Costain Vicky Gallant (AD.)	Regena Kaye Russell Law Corp. PO Box 383 O'Leary, PE
PETERS, Mary Doris Charlottetown Queens Co., PE February 17th, 2007 (07-20)	Doris Smith (AD.)	Lyle & McCabe PO Box 300 Summerside, PE
ARSENAULT, Leona Mary Summerside Prince Co., PE February 10th, 2007 (06-19)	Judith Collicutt (also known as Judy Collicutt and Judie Collicutt) Gary W. Arsenaault (EX.)	Lyle & McCabe PO Box 300 Summerside, PE

**CANADA  
PROVINCE OF PRINCE EDWARD ISLAND  
IN THE SUPREME COURT - ESTATES DIVISION**

TAKE NOTICE that all persons indebted to the following estates must make payment to the personal representative of the estates noted below, and that all persons having any demands upon the following estates must present such demands to the representative within six months of the date of the advertisement:

Estate of: Date of the Advertisement	Personal Representative: Executor/Executrix (Ex) Administrator/Administratrix (Ad)	Place of Payment
BOLGER, Arlene Edith (also known as Arlene Edith Agnes Gaudet) Summerside Prince Co., PE February 10th, 2007 (06-19)	Shannon Gallant Shelley Gaudet (EX.)	Lyle & McCabe PO Box 300 Summerside, PE
DYKEMAN, Chalmers Wayne Charlottetown Queens Co., PE February 17th, 2007 (07-20)	Judith Elizabeth Killorn Joanne Margaret Paquet Susan Lynn Gould (EX.)	Stewart McKelvey Stirling Scales PO Box 2140 Charlottetown, PE
MATTHEWS, Lloyd George O'Leary Prince Co., PE February 10th, 2007 (06-19)	Dale Dennis (EX.)	Key McKnight & Maynard PO Box 177 O'Leary, PE
MEEK, Eleanor Joyce Charlottetown Queens Co., PE February 10th, 2007 (06-19)	Douglas H. Meek (EX.)	McInnes Cooper BDC Place Suite 620, 119 Kent Street Charlottetown, PE
PETERS, John Eric (also known as Jean "Eric" T. Peters) Charlottetown Queens Co., PE February 10th, 2007 (06-19)	Suzanne Danielle Peters (EX.)	T. Daniel Tweel 105 Kent Street Charlottetown, PE
GALLANT, Antoine Dorisse Charlottetown Queens Co., PE February 10th, 2007 (06-19)	Brian Gallant (AD.)	McInnes Cooper BDC Place Suite 620, 119 Kent Street Charlottetown, PE
HASLAM, Blanche Nina Kensington Prince Co., PE February 3rd, 2007 (05-18)	Vivian Blanche Clark (EX.)	McLellan Brennan PO Box 35 Summerside, PE
JACKSON, George H. Fortune Kings Co., PE February 3rd, 2007 (05-18)	Ethel MacKenzie (EX.)	Allen J. MacPhee Law Corporation PO Box 238 Souris, PE

**CANADA  
PROVINCE OF PRINCE EDWARD ISLAND  
IN THE SUPREME COURT - ESTATES DIVISION**

TAKE NOTICE that all persons indebted to the following estates must make payment to the personal representative of the estates noted below, and that all persons having any demands upon the following estates must present such demands to the representative within six months of the date of the advertisement:

Estate of: Date of the Advertisement	Personal Representative: Executor/Executrix (Ex) Administrator/Administratrix (Ad)	Place of Payment
MacGUIGAN, James O. Toronto Ontario February 3rd, 2007 (05-18)	J. David MacGuigan R. Janice Heisey Karen M. MacGuigan (EX.)	Cox & Palmer PO Box 486 Charlottetown, PE
RAMSAY, Blair Grant Kensington Prince Co., PE February 3rd, 2007 (05-18)	A. Debra A. Ramsay (EX.)	Key McKnight & Maynard PO Box 1570 Summerside, PE
ARSENAULT, Hilda Charlotte Summerside Prince Co., PE February 3rd, 2007 (05-18)	Emily Charlotte Durant (AD.)	Cox & Palmer 82 Summer Street Summerside, PE
MOASE, Grace Maria Summerside Prince Co., PE February 3rd, 2007 (05-18)	Grant Moase Leta MacLean (AD.)	Ramsay & Clark PO Box 96 Summerside, PE
RAMSAY, Grace Lilly Summerside Prince Co., PE February 3rd, 2007 (05-18)	John Edward Dalton (AD.)	Ramsay & Clark PO Box 96 Summerside, PE
CAMERON, Charles Cleyon Summerside Prince Co., PE January 27th, 2007 (04-17)	Colleen Davis (EX.)	Key McKnight & Maynard PO Box 1570 Summerside, PE
GREENAN, Gerald John Freetown Prince Co., PE January 27th, 2007 (04-17)	Rita White (EX.)	Cox & Palmer 82 Summer Street Summerside, PE
MacKINNON, Peter Goose River Kings Co., PE January 27th, 2007 (04-17)	Alice MacKinnon (EX.)	Law Office of Alfred K. Fraser, QC PO Box 516 Montague, PE
McASSEY, Cecil Alleyne Charlottetown Queens Co., PE January 27th, 2007 (04-17)	Lawrence Coffin Leonard McAssey (EX.)	Campbell Stewart PO Box 485 Charlottetown, PE

**CANADA  
PROVINCE OF PRINCE EDWARD ISLAND  
IN THE SUPREME COURT - ESTATES DIVISION**

TAKE NOTICE that all persons indebted to the following estates must make payment to the personal representative of the estates noted below, and that all persons having any demands upon the following estates must present such demands to the representative within six months of the date of the advertisement:

Estate of: Date of the Advertisement	Personal Representative: Executor/Executrix (Ex) Administrator/Administratrix (Ad)	Place of Payment
MacCALLUM, Rosella Coleman Prince Co., PE January 27th, 2007 (04-17)	Marie Compton (AD.)	J. Allan Shaw Law Corporation PO Box 40 Alberton, PE
MacLEAN, Sheila Marie Tracadie Cross Queens Co., PE January 27th, 2007 (04-17)	Patricia Sands (AD.)	Michele M. Murphy, QC Law Office 75 Fitzroy Street, Suite 301 Charlottetown, PE
KELLY, Beverly Ann (Anne) Charlottetown Queens Co., PE January 13th, 2007 (02-17)	Lisa Geldert (EX.)	Birt & McNeill 138 St. Peters Rd. Charlottetown, PE

The following order was approved by Her Honour the Lieutenant Governor in Council dated 17 April 2007.

**EC2007-242**

**FATHERS OF CONFEDERATION BUILDINGS ACT  
FATHERS OF CONFEDERATION BUILDINGS TRUST  
APPOINTMENTS**

Pursuant to subsection 3(1) of the *Fathers of Confederation Buildings Act* R.S.P.E.I. 1988, Cap. F-6 Council made the following appointments:

<b>NAME</b>	<b>TERM OF APPOINTMENT</b>
Ann Kelly Winsloe (reappointed)	4 February 2007 to 31 July 2009
Michael Schurman Summerside (reappointed)	4 February 2007 to 31 July 2009

Signed,

W. Alexander (Sandy) Stewart  
Clerk of the Executive Council

**NOTICE OF DISSOLUTION**

*Partnership Act*  
R.S.P.E.I. 1988, Cap. P-1

Public Notice is hereby given that a Notice of Dissolution has been filed under the *Partnership Act* for each of the following:

Name: BALDERSTON MACKENZIE  
PRODUCE  
Owner: Greg F. MacKenzie  
Registration Date: April 18, 2007

Name: MONTAGUE TIMBER  
Owner: Ronald Hurley  
Registration Date: April 19, 2007

Name: STANLEY BRIDGE STUDIO  
Owner: Lyall Rombough  
Stephen Christensen  
Registration Date: April 18, 2007

Name: TNT MARKETING  
Owner: Terry Jeffery  
Registration Date: April 18, 2007

**NOTICE OF GRANTING  
LETTERS PATENT**

*Companies Act*  
R.S.P.E.I. 1988, Cap. C-14, s.11,

Public Notice is hereby given that under the *Companies Act* Letters Patent have been issued by the Minister to the following:

Name: 100871 P.E.I. INC.  
20 Stratford Road  
Stratford, PE C1B 1T5  
Incorporation Date: April 19, 2007

Name: CAPES OF ST. LAWRENCE LOT  
OWNERS ASSOCIATION LIMITED  
R R # 6, Kensington, PE C0B 1M0  
Incorporation Date: April 20, 2007

Name: GATEWAY P.E.I. INC.  
200 - 70 Kent Street  
Charlottetown, PE C1A 1M9  
Incorporation Date: April 19, 2007

Name: RAM HOLDINGS LTD.  
50 Water Street  
Box 522, Charlottetown, PE C1A 7L1  
Incorporation Date: April 18, 2007

Name: TNT MARKETING INC.  
14 Lilac Avenue  
Charlottetown, PE C1A 6L2  
Incorporation Date: April 18, 2007

**NOTICE OF GRANTING  
SUPPLEMENTARY LETTERS PATENT**

*Companies Act*  
R.S.P.E.I. 1988, Cap. C-14, s.18, s.3

Public Notice is hereby given that under the *Companies Act* supplementary letters patent have been issued by the Minister to the following:

Name: GEONET TECHNOLOGIES INC.  
Purpose To increase the authorized capital.  
Effective Date: April 20, 2007

Name: SIGN STATION INC.  
Purpose To increase the authorized capital.  
Effective Date: April 18, 2007

Name: TOWNSHEND POTATO  
COMPANY LTD.  
Purpose To increase the authorized capital.  
Effective Date: April 23, 2007

**NOTICE OF REGISTRATION**

*Partnership Act*  
R.S.P.E.I. 1988, Cap. P-1, s.52 and s.54(1)

Public Notice is hereby given that the following Declarations have been filed under the *Partnership Act*:

Name: PFI GROUP  
Owner: PRECISION FINISH INC.  
Tignish, PE C0B 2B0  
Registration Date: April 18, 2007

Name: WESTERN TRUSS  
Owner: MCCARTHY'S WOODWORKING INC.  
1689 Dock Road  
Elmsdale, PE C0B 1K0  
Registration Date: April 19, 2007

Name: PRINCE EDWARD ISLAND  
RESTAURANT & MENU GUIDE  
Owner: IMAGEWORKS (P.E.I.) INC.  
51 Water Street  
Charlottetown, PE C1A 1A3  
Registration Date: April 19, 2007

Name: BRAUN CANADA  
 Owner: PROCTER & GAMBLE INC.  
 4711 Yonge Street  
 North York, ON M2N 6K8  
 Registration Date: April 20, 2007

Name: ZOOOTH CANADA  
 Owner: PROCTER & GAMBLE INC.  
 4711 Yonge Street  
 North York, ON M2N 6K8  
 Registration Date: April 20, 2007

Name: JETSTAR COLLISION SERVICES  
 Owner: LAWMARK LTD.  
 189 Brackley Point Road  
 Charlottetown, PE C1A 6Z2  
 Registration Date: April 20, 2007

Name: BRADSHAW BROTHERS  
 ENTERPRISES  
 Owner: David Bradshaw  
 731 7th St.  
 Slemon Park, Box 23  
 Summerside, PE C0B 2A0  
 Owner: Jason Bradshaw  
 171 Milligans Wharf Road  
 R R # 2  
 Ellerslie, PE C0B 1J0  
 Registration Date: April 20, 2007

Name: DAVE FEENER PAINTING  
 Owner: Dave Feener  
 2 Cannon Drive  
 Charlottetown, PE C1A 9G2  
 Registration Date: April 19, 2007

Name: FUTURE FUELS  
 Owner: Natalie Simmons  
 1500 Waterview Road  
 Summerside PE C1N 4J8  
 Registration Date: April 20, 2007

Name: GODFREY CONSTRUCTION  
 Owner: Thomas J. Godfrey  
 65 Beach Grove Road  
 Charlottetown, PE C1E 1J4  
 Registration Date: April 19, 2007

Name: ISLAND FARM GIRLS  
 Owner: Mirjana Laurence  
 753 Appin Road  
 Bonshaw, PE C0A 1C0  
 Registration Date: April 19, 2007

Name: JEMA'S COTTAGE  
 Owner: Marc Périard  
 50 Creekside Drive  
 Stratford, PE C1B 2W9  
 Owner: Jennifer Jardine  
 50 Creekside Drive  
 Stratford, PE C1B 2W9  
 Registration Date: April 13, 2007

Name: LAWNS AND BEYOND  
 Owner: Mark D. H. Tremere  
 327 York Road  
 York, PE C0A 1P0  
 Registration Date: April 20, 2007

Name: MACKENZIE PRODUCE  
 Owner: Greg F. MacKenzie  
 10903 TCH  
 Stratford, PE C1B 2R7  
 Registration Date: April 18, 2007

Name: MALPEQUE BAY TRANQUIL  
 COTTAGES  
 Owner: William Dickie  
 170 Highview Road  
 Box 4541, RR 3  
 Summerside, PE C1N 4J9  
 Owner: Wanda Dickie  
 170 Highview Road  
 Box 4541, RR 3  
 Summerside, PE C1N 4J9  
 Registration Date: April 20, 2007

Name: PEACE OF MIND PROPERTY  
 MANAGEMENT  
 Owner: Valmond Murray  
 R R # 1, Belfast, PE C0A 1A0  
 Registration Date: April 19, 2007

Name: PEI UPHOLSTERY  
 Owner: Gary Ramsay  
 375 Northmarket  
 Summerside, PE C1N 1L7  
 Registration Date: April 20, 2007

Name: SANDY SPRUCE  
 Owner: William C. Cassidy  
 14 Pierce Avenue  
 Westford, MA 01886  
 Owner: Laura A. Cassidy  
 14 Pierce Avenue  
 Westford, MA 01886  
 Registration Date: April 17, 2007



Name: SHAREHOLDER CLAIMANTS  
AGAINST PITRE  
DEVELOPMENTS INC. AND  
NORTHSHORE DEVELOPMENTS  
INC. (TBI)  
Owner: Randy Pitre  
150 Upper Prince St.  
Charlottetown, PE C1A 4R6  
Owner: Harold Coade  
Winsloe, PE C1E 1Z4  
Owner: Barry Sherren  
4 Harland View Drive  
Stratford, PE C1B 1W3  
Registration Date: April 19, 2007

Name: SIGNATURE PROPERTY  
MAINTENANCE  
Owner: Barret Campbell  
Box 569, Kensington, PE C0B 1M0  
Registration Date: April 23, 2007

Name: STANLEY BRIDGE STUDIOS  
Owner: Stephen Christensen  
R R # 2  
North Wiltshire, PE C0A 1Y0  
Registration Date: April 18, 2007

Name: THE TURRET BELL  
Owner: Jay Adamsson  
5707 St. Peter's Rd.  
Box 63, St. Peter's, PE C0A 2A0  
Owner: Michelle MacDonald  
5707 St. Peter's Rd.  
Box 63, St. Peters, PE C0A 2A0  
Registration Date: April 18, 2007

Name: WILLIE DOYLE VINYL SIDING  
Owner: Willie Doyle  
5 Moreau Drive  
Charlottetown, PE C1A 2Y1  
Registration Date: April 20, 2007

17

**NOTICE OF  
REVIVED COMPANIES**  
*Companies Act*  
R.S.P.E.I. 1988, Cap. C-14 s.73

Public Notice is hereby given that under the *Companies Act* the following companies have been revived:

Name: MARITIME ANIMAL PROTEIN  
PRODUCTS LTD.  
Effective Date: April 20, 2007

17

<http://www.gov.pe.ca/royalgazette>

**NOTICE OF INTENTION  
TO DISCONTINUE**

PUBLIC NOTICE is hereby given that **BACKBONE CHARLOTTETOWN LTD.**, a body corporate, duly incorporated under the laws of the Province of Prince Edward Island, intends to make application to continue as a corporation under the laws of the Province of Nova Scotia as if it had been incorporated under the laws of that jurisdiction and to discontinue as a company pursuant to the provisions of the *Companies Act* of Prince Edward Island.

BACKBONE CHARLOTTETOWN LTD. will continue to conduct business in Prince Edward Island and will maintain its operations in Prince Edward Island.

DATED this 23rd day of April, 2007.

Curtis A. Toombs  
Solicitor for the Applicant  
Stewart McKelvey  
Barristers and Solicitors

17

**NOTICE UNDER THE  
QUIETING TITLES ACT**

TAKE NOTICE that **JOHN MUNGALL**, of the City of Summerside, in Prince County, in the Province of Prince Edward Island, claims to be the absolute owner of the lands hereinafter described.

AND TAKE NOTICE that an application has been made to the Supreme Court of the Province of Prince Edward Island on behalf of John Mungall, to have the title judicially investigated and the validity thereof ascertained and declared to the lands and premises described as follows:

ALL that parcel of land, lying and being at Lower Bedeque, Township No. 26, in Prince County, Prince Edward Island, being more particularly described on a "Plan of Survey Showing the Lands of Edith Mungall" prepared by Locus Surveys Ltd., dated the 15th day of September 2006, as Drawing No. 98392D, bounded and described as follows:

COMMENCING at the point of intersection of the westerly margin of Leard's Lane and the southerly margin of Hector Lane marked by a placed survey marker #2959 having coordinates E. 298306.379, N. 376587.293 feet;

THENCE southwesterly following the western margin Leard's Lane being a 20 foot wide right of way on an azimuth 209° 04' 08" for a distance of 241.40 feet to SSM #2961;

THENCE continuing southwesterly on an azimuth 207° 42' 08" for a distance of 360.64 feet to SSM #2953;

THENCE southerly on an azimuth 185° 26' 37" for a distance of 104.00 feet to a calculated point #4394 to the northeast boundary of lands now or formerly owned by H. Marguerite MacEwen;

THENCE northwesterly along the northerly boundary of lands aforesaid on an azimuth 322° 11' 25" for a distance of 96.00 feet to CP #4393;

THENCE southerly along the western boundary of lands aforesaid on an azimuth 185° 26' 37" for a distance of 41.35 feet to CP #4317;

THENCE continuing along the western boundary of lands aforesaid on an azimuth 215° 29' 29" for a distance of 67.66 feet to CP #2965;

THENCE continuing southwesterly on an azimuth 215° 29' 29" to the point of intersection with the high water mark of Salutation Cove;

THENCE northwesterly following the various courses of the ordinary high water mark of Salutation Cove for an approximate distance of 791 feet to the point of intersection with a line in prolongation southwestward from SSM 2939, said line on an azimuth of 26° 30' 33";

THENCE northeasterly on an azimuth of 26° 30' 33" for an approximate distance of 24 feet more or less to SSM #2939;

THENCE continuing northeasterly along the eastern boundary of lands now or formerly of Marilyn J. Affleck and on an azimuth of 26° 30' 33" for a distance of 309.66 feet to the southerly margin of the Hector Lane to SSM #2936 there located;

THENCE northeasterly following along the southern margin of the said Hector Lane on a curve having a radius of 108.55 feet for an arc distance of 29.79 feet to CP 2962;

THENCE northeasterly along the southern margin of the aforesaid Hector Lane on an azimuth of 80° 41' 24" for a distance of 177.98 feet to SSM #2963;

THENCE easterly along the southern margin of Hector Lane following the curve of an arc having a radius of 110.00 feet for an arc distance of 78.97 feet to SSM #2964;

THENCE southeasterly along the southern margin of Hector Lane on an azimuth of 123° 26' 00" for a distance of 493.22 feet to SSM #2959 being the point at the place of commencement.

BEING AND INTENDED TO BE now or formerly the lands of John Mungall reported to be the lands of Edith Mungall.

CONTAINING 10.3 Acres of land a little more or less.

All grid azimuths and co-ordinates are referenced to the PEI Stereographic Projection, prior to July 1, 1979.

All dimensions are given in feet, unless noted.

Any person claiming adverse title or interest in the said land is to file Notice of the same with the Deputy Registrar of the Supreme Court in the Law Courts Building at Summerside, Prince County, Prince Edward Island on or before the 4th day of June A.D. 2007.

AND TAKE FURTHER NOTICE that if no claim to the said lands adverse to that of John Mungall is filed on or before the 4th day of June A.D. 2007, a Certificate of Title certifying that John Mungall is the legal and beneficial owner in fee simple of the said lands will be granted pursuant to the provisions of the *Quieting Titles Act*, subject to the exceptions and qualifications mentioned in Section 22 exclusive of sub section (1) (b) of the said Act, but free from all other rights, interests, claims and demands whatsoever.

DATED at the City of Summerside, Prince County, Prince Edward Island, this 10th day of April, A.D. 2007.

George A. Lyle, Esq.  
Solicitor for the Petitioner  
Lyle & McCabe  
290 Water Street  
P.O. Box 300  
Summerside, PE C1N 4Y8

**NOTICE**  
**MARRIAGE ACT**  
Prince Edward Island  
[Subsection 8(1) of the Act]

Notice is hereby published that, under the authority of the *Marriage Act*, the following clergy has been **temporarily registered from June 23, 2007 to July 7, 2007** for the purpose of solemnizing marriage in the province of Prince Edward Island:

**Rev. Gary Andrews**  
17 Finn Ave.  
Grand Falls-Windsor, NL A2A 2M7

T.A. Johnston  
Director of Vital Statistics

17

**NOTICE**  
**MARRIAGE ACT**  
Prince Edward Island  
[Subsection 8(1) of the Act]

Notice is hereby published that, under the authority of the *Marriage Act*, the following clergy has been **temporarily registered from July 27, 2007 to August 10, 2007** for the purpose of solemnizing marriage in the province of Prince Edward Island:

**Rev. Dennis R. Leamont**  
Box 3330, RR 1  
Arcadie, NS B0W 1B0

T.A. Johnston  
Director of Vital Statistics

17

**NOTICE**  
**MARRIAGE ACT**  
Prince Edward Island  
[Subsection 8(1) of the Act]

Notice is hereby published that, under the authority of the *Marriage Act*, the following clergy has been **temporarily registered from August 18, 2007 to September 1, 2007** for the purpose of solemnizing marriage in the province of Prince Edward Island:

**Rev. Kenneth MacRae**  
3 Queen St.  
Sydney Mines, NS B1V 1K4

T.A. Johnston  
Director of Vital Statistics

17

**INDEX TO NEW MATTER**  
**April 28, 2007**

**ESTATE NOTICES****Administrators' Notices**

Collicutt, Elsie B. ....	349
Winsloe, Amelia A. ....	349

**Executors' Notices**

Carr, Eric Robert ....	349
MacDonald, Mary Gemma ....	349
O'Brien, Bertha ....	349
O'Brien, Bertha Ann ....	349

**COMPANIES ACT NOTICES****Granting Letters Patent**

100871 P.E.I. Inc. ....	363
Capes of St. Lawrence Lot Owners Association Limited ....	363
Gateway P.E.I. Inc. ....	363
Ram Holdings Ltd. ....	363
TNT Marketing Inc. ....	363

**Granting Supplementary Letters Patent**

Geonet Technologies Inc. ....	363
Sign Station Inc. ....	363
Townshend Potato Company Ltd. ....	363

**Intention to Discontinue**

Backbone Charlottetown Ltd. ....	365
----------------------------------	-----

**Revived Companies**

Maritime Animal Protein Products Ltd. . .	365
---	-----

**PARTNERSHIP ACT NOTICES****Dissolutions**

Balderston MacKenzie Produce ....	363
Montague Timber ....	363
Stanley Bridge Studio ....	363
T'N'T Marketing ....	363

**Registrations**

Bradshaw Brothers Enterprises ....	364
Braun Canada ....	364
Dave Feener Painting ....	364
Future Fuels ....	364
Godfrey Construction ....	364
Island Farm Girls ....	364
Jema's Cottage ....	364
Jetstar Collision Services ....	364
Lawns and Beyond ....	364
MacKenzie Produce ....	364

Malpeque Bay Tranquil Cottages . . . . .	364
Peace of Mind Property Management . . . . .	364
PEI Group . . . . .	363
PEI Upholstery . . . . .	364
Prince Edward Island Restaurant & Menu Guide . . . . .	363
Sandy Spruce . . . . .	364
Shareholder Claimants Against Pitre Developments Inc. And Northshore Developments Inc. (TBI) . . . . .	365
Signature Property Maintenance . . . . .	365
Stanley Bridge Studios . . . . .	365
Turret Bell, The . . . . .	365
Western Truss . . . . .	363
Willie Doyle Vinyl Siding . . . . .	365
Zooth Canada . . . . .	364

**APPOINTMENTS****Fathers of Confederation Buildings Act**

Fathers of Confederation Buildings Trust Kelly, Ann . . . . .	362
Schurman, Michael . . . . .	362

**MISCELLANEOUS NOTICES****Marriage Act**

Temporarily Registered Andrews, Rev. Gary . . . . .	367
Leamont, Rev. Dennis R. . . . .	367
MacRae, Rev. Kenneth . . . . .	367

**Quieting Titles Act**

Property of Mungall, John . . . . .	365
--	-----

The ROYAL GAZETTE is issued every Saturday from the office of Michael Fagan, Queen's Printer, PO Box 2000, Charlottetown, PEI C1A 7N8. All copy must be received by the Tuesday preceding day of publication. The subscription rate is \$55.00 per annum, postpaid; single copies are \$2.00 each, postpaid or \$1.00 each, over the counter.

---

**PART II**  
**REGULATIONS**

---

**EC2007-239**

**ENVIRONMENTAL PROTECTION ACT**  
**EXCAVATION PITS REGULATIONS**  
**AMENDMENT**

(Approved by Her Honour the Lieutenant Governor in Council dated 17 April 2007.)

Pursuant to section 25 of the *Environmental Protection Act* R.S.P.E.I. 1988, Cap. E-9, Council made the following regulations:

**1. Section 1 of the *Environmental Protection Act* Excavation Pits Regulations (EC753/90) is amended**

**(a) by the addition of the following after clause (a):**

(a.1) “Act” means the *Environmental Protection Act* R.S.P.E.I. 1988, Act Cap. E-9;

**(b) by the revocation of clause (g) and the substitution of the following:**

(g) “residential premises” or “premises” includes residential premises

(i) any house, dwelling, apartment, flat, tenement or other place that is occupied or may be occupied by a natural person as a residence or that part of any such place that is or may be occupied by a natural person as a residence, whether such residential premises are furnished, partly furnished or unfurnished, and

(ii) land rented as a mobile home site whether or not the lessor also rents that mobile home to the lessee,

but does not include premises exempted by these regulations;

**2. (1) Section 3 of the regulations is amended**

**(a) by the revocation of subsection (1) and the substitution of the following:**

**3. (1)** A contractor or a property owner who wishes to obtain a permit to open or operate an excavation pit shall apply for the permit on a form approved by the Minister and pay the fee of \$100. Application for permit

**(b) in subsection (3),**

**(i) in clause (i), by the deletion of the words “for the pit; and” and the substitution of the words “for the pit;”,**

- (ii) in clause (j), by the addition of the word “and” after the semicolon, and  
 (iii) by the revocation of clause (k).

**(2) Subsections 3(6) and (7) of the regulations are revoked and the following substituted:**

Bond (6) The Minister may require an applicant to post a bond, in an amount and for a term acceptable to the Minister, to cover the costs of restoration of the site in accordance with the plan submitted with the application under clause 3(3)(j).

**3. The regulations are amended by the addition of the following after the heading “PERMITS”:**

Minister may issue permit **4.1 (1)** Subject to section 4, the Minister may issue a permit to an applicant on an application made under subsection 3(1), if the Minister considers that

- (a) the application complies with section 3;
- (b) the application is in the public interest;
- (c) the operation of the proposed excavation pit would result in a substantial improvement to the usefulness and appearance of the property subject to the permit;
- (d) the operation of the proposed excavation pit would not represent a hazard to the public or result in damage to the environment; and
- (e) where the Minister has required a bond to be posted under subsection 3(6), the applicant has posted such a bond.

Permit expires (2) A permit issued under this section expires on January 31 of the year following its issue.

**4. Section 4 of the regulations is amended**

**(a) in subsection (1),**

**(i) by the revocation of clause (d) and the substitution of the following:**

- (d) if any part of a proposed excavation pit is within 300 metres of any residential premises other than a residence occupied by the applicant;
- (d.1) if any part of a proposed excavation pit is within 500 metres of any church, school, hospital, nursing home, cemetery, public hall, bathing beach, public skating rink, public park or public playground;

**(ii) by the revocation of clause (j); and**

**(b) by the revocation of subsection (3) and the substitution of the following:**

Exception (3) Notwithstanding anything to the contrary in subsection (2), the Minister may issue a permit under subsection 4.1(1), if

- (a) the owners of all residential premises within 101 to 300 metres of any part of the proposed excavation pit acknowledge in writing that they have no objection to the proposed excavation pit; and
- (b) no residential premises are located within 100 metres of the proposed excavation pit.

**5. Section 9 of the regulations is revoked.**

**6. These regulations come into force on April 28, 2007.**

#### EXPLANATORY NOTES

**SECTION 1** adds a definition and revokes a definition that is already contained in the Act.

**SECTION 2** removes the reference to a bond in the application details and provides more specific requirements for a bond in a separate subsection.

**SECTION 3** deals with application for a permit, the issuance of a permit by the Minister and the expiry of a permit.

**SECTION 4** deals with the proximity of an excavation pit to residential premises or areas used by the public.

**SECTION 5** revokes section 9 of the regulations because it is redundant to section 32 of the Act.

**SECTION 6** provides for the commencement of these regulations.

Certified a true copy,

W. Alexander (Sandy) Stewart  
Clerk of the Executive Council

---

## EC2007-240

**ENVIRONMENTAL PROTECTION ACT  
PETROLEUM STORAGE TANKS REGULATIONS**

(Approved by Her Honour the Lieutenant Governor in Council dated 17 April 2007.)

Pursuant to section 25 of the *Environmental Protection Act* R.S.P.E.I. 1988, Cap. E-9, Council made the following regulations:

Definitions	<b>1. (1)</b> In these regulations
aboveground storage tank	(a) “aboveground storage tank” means the aboveground installation of a storage tank where at least 90% of the storage tank volume is above the floor or the ground surface, as the case may be;
Act	(b) “Act” means the <i>Environmental Protection Act</i> R.S.P.E.I. 1988, Cap. E-9;
alter	(c) “alter” means to repair, replace, upgrade, move or remove any part of a storage tank or storage tank system, but does not include regular maintenance servicing of the components of such a system;
API	(d) “API” means American Petroleum Institute;
ASTM	(e) “ASTM” means the American Society for Testing and Materials;
bulk petroleum sales outlet	(f) “bulk petroleum sales outlet” means a place where petroleum is contained in storage tank systems at a fixed location by a wholesaler for delivery to retail outlets or for direct delivery to purchasers;
cathodic protection	(g) “cathodic protection” means a method of preventing or reducing corrosion to a metal surface by making the metal a cathode using either an impressed direct current or by attaching sacrificial anodes;
Certificate of Compliance	(h) “Certificate of Compliance” means a Certificate of Compliance completed in accordance with subsection 9(1);
Class 1 liquid	(i) “Class 1 liquid” means a liquid petroleum that has a flash point below 30 degrees C;
corrosion specialist	(j) “corrosion specialist” means (i) a person recognized by the National Association of Corrosion Engineers as a corrosion technician, or (ii) a person who has successfully completed such training programs and examinations as may be designated by the Minister;
Level 1 Licence	(k) “Level 1 Licence” means a Level 1 Petroleum Storage Tank Contractor Licence issued by the Minister under subsection 3(2);
Level 2 Licence	(l) “Level 2 Licence” means a Level 2 Petroleum Storage Tank Contractor Licence issued by the Minister under subsection 3(3);



- (m) “licensee” means a person who holds a Level 1 or Level 2 Licence; licensee
- (n) “National Fire Code of Canada” means the National Fire Code of Canada, as amended; National Fire Code of Canada
- (o) “NFPA” means the National Fire Prevention Association; NFPA
- (p) “nominal capacity” means the capacity of a storage tank as established by the manufacturer; nominal capacity
- (q) “non-compliant” in respect of a storage tank or a storage tank system, means non-compliant with these regulations; non-compliant
- (r) “operator” means the person responsible for the day to day maintenance or operation of a storage tank or a storage tank system and includes the owner, lessee or manager of a storage tank or storage tank system; operator
- (s) “out-of-service” means a storage tank that is not being used to dispense petroleum or cannot dispense petroleum; out-of-service
- (t) “owner” means the person who owns, controls or manages a storage tank or storage tank system; owner
- (u) “petroleum” means a mixture of petroleum hydrocarbons in liquid form, with or without additives, that is used or can be used as a combustible fuel for heating purposes; petroleum
- (v) “precast concrete containment vault” means a liquid-tight steel-reinforced precast concrete structure that is manufactured according to the ASTM standard C-858-83 with the exception that the minimum compressive strength (ASTM section 7.6) for the design shall be 4500 psi at 28 days of age; precast concrete containment vault
- (w) “prior regulations” means the Petroleum Storage Tank Regulations (EC322/01) made under the Act and revoked by these regulations; prior regulations
- (x) “product piping” means piping that is installed on a storage tank to convey petroleum from the storage tank to a point of use; product piping
- (y) “reconcile” means reconcile
- (i) to obtain
- (A) storage tank dip measurements,
- (B) dispenser meter readings, or
- (C) in the case of a storage tank connected to a heating appliance, fuel consumption records, and
- (ii) to compare the measurements, readings and records referred to in subclause (i), for the purpose of identifying any differences or discrepancies that may be unaccounted for in such comparison;
- (z) “regular maintenance servicing” means to regularly service for maintenance purposes such components of a storage tank or storage regular maintenance servicing

	tank system including filters, hoses and nozzles as would affect the routine operation of a storage tank or a storage tank system;
retail outlet	(z.1) “retail outlet” means a place where petroleum is stored at a fixed location from which delivery of petroleum is made directly to the users;
storage tank	(z.2) “storage tank” means a storage tank that is used or designed to be used for the storage of any kind of liquid petroleum, that <ul style="list-style-type: none"> <li>(i) is an underground storage tank,</li> <li>(ii) is an aboveground storage tank with a capacity of more than 2200 litres, installed at or in use at a bulk petroleum sales outlet or a retail outlet, or</li> <li>(iii) is part of a field-erected aboveground storage tank system that falls within the requirements of the standard API 650-Welded Steel Tanks for Oil Storage;</li> </ul>
storage tank system	(z.3) “storage tank system” means one or more storage tanks together with all piping connecting the storage tanks, both aboveground and underground, including pumps and product transfer apparatus, dyking, and associated spill containment and collection apparatus;
underground storage tank	(z.4) “underground storage tank” means a storage tank that is not an aboveground storage tank.
Application	(2) These regulations apply to storage tanks and storage tank systems.

#### LICENCES

Payable to Provincial Treasurer	<b>2.</b> (1) The fees for an application for, or renewal of, a licence under these regulations shall be made payable to the Provincial Treasurer.
Application fees	(2) The fee for an application for, or a renewal of, a licence is <ul style="list-style-type: none"> <li>(a) \$50 for a Level 1 Licence; and</li> <li>(b) \$100 for a Level 2 Licence.</li> </ul>
Application for licence	<b>3.</b> (1) A person who wishes to perform the work of a petroleum storage tank contractor shall apply for a Level 1 or Level 2 Contractor Licence by <ul style="list-style-type: none"> <li>(a) submitting an application to the Minister on Form 2;</li> <li>(b) providing such proof of the matters referred to in subsection (2) or (3) as the Minister may require;</li> <li>(c) providing such other information as the Minister may require; and</li> <li>(d) submitting the application fee.</li> </ul>
Level 1 licence	(2) The Minister may issue a Level 1 Licence on Form 3 to a person who has successfully completed a written examination approved by the Minister with a mark in the examination of not less than 75%.
Level 2 licence	(3) The Minister may issue a Level 2 Licence on Form 3 to a person who

- (a) has successfully completed, within the two years prior to the application,
- (i) the Petroleum Storage Tank System Installers Training Course at the Nova Scotia Community College, or
  - (ii) a similar course to the course referred to in subclause (i), if approved by the Minister;
- (b) submits a certificate of insurance coverage, during the period of the licence, for the licensee's liability for bodily injury and property damage, including damages arising, during the period of coverage, from a contaminant being introduced into the environment in a sudden, unintended or unexpected occurrence, and with not less than \$1,000,000 coverage per occurrence; and
- (c) submits proof that the insurance required by clause (b) contains a statement that the insurance coverage may not be cancelled except on thirty days prior written notice to the Minister.
- (4) A licence issued under the prior regulations that was valid immediately before the date these regulations came into force is deemed
- (a) to be a licence issued under subsection (2) at the level shown on the licence; and
  - (b) to expire on January 31, 2008.
- (5) The Minister may, on application and payment of the application fee, renew a Level 1 Licence for a person who held a Level 1 Licence within the 48 months previous to the application.
- (6) The Minister may, on application and payment of the application fee, renew a Level 2 Licence for a person who
- (a) held a Level 2 Licence within the 24 months previous to the application; and
  - (b) has submitted the certificate of insurance coverage and proof of the prior notice of insurance cancellation as required by clauses (3)(b) and (c).
- (7) A licence issued or renewed under this section expires on January 31 of the year following the date of issue or renewal of the licence.
- (8) A person who holds a Level 1 Licence is authorized to remove a storage tank or a storage tank system.
- (9) A person who holds a Level 2 Licence is authorized to remove, install or alter a storage tank or a storage tank system.
4. (1) The Minister may revoke a licence issued under subsection 3(2) or (3) or renewed under subsection 3(5) or (6), where, in the Minister's opinion,
- (a) a licensee has contravened the Act or these regulations; or
  - (b) in the case of a level 2 Licence, the insurance required under clause 3(3)(b) has expired or been terminated.

- Notice of revocation (2) The Minister shall give notice of the revocation of a licence to the licensee pursuant to subsection (1) by
- (a) personal service; or
  - (b) by registered mail to the last known address of the licensee as shown in the records of the Minister.
- Service (3) A notice sent by registered mail under clause (2)(b) shall be deemed to be served on the licensee
- (a) on the date the licensee actually receives the notice; or
  - (b) 5 days after the date on which the notice was mailed, whichever is earlier.

#### INSTALLATION, ALTERATION

- Application to install system **5.** (1) Subject to subsection 6(1), an owner who intends to have a storage tank or storage tank system installed or altered shall
- (a) submit an application to the Minister on Form 1
    - (i) in the case of a proposed installation, at least 20 working days in advance of the proposed installation; or
    - (ii) in the case of a proposed alteration, at least 18 working days in advance of the proposed alteration; and
  - (b) include in the application submitted under clause (a) such other information as the Minister may require.
- Approve, or reject (2) Upon receipt of an application made under subsection (1), the Minister shall, in writing within 14 working days of receiving the application,
- (a) approve the proposed installation or alteration subject to compliance by the owner with the minimum installation standards prescribed by these regulations and such other terms and conditions as the Minister considers necessary; or
  - (b) reject the application on the grounds that the installation or alteration cannot be undertaken because
    - (i) the application did not contain sufficient information;
    - (ii) the storage tank system cannot be installed or altered as proposed due to the Minister's concerns for the protection of the environment; or
    - (iii) the installation or alteration as proposed would not comply with these regulations.
- Approval valid for 12 months (3) Unless earlier revoked under these regulations, an approval granted under clause (2)(a) is valid for twelve months from the date of its issue.
- Emergency alteration **6.** (1) Where the owner of a storage tank or a storage tank system needs to make an emergency alteration to prevent petroleum leakage, the owner may proceed to have the alterations performed by a Level 2 licensee without an approval issued under clause 5(2)(a).
- Notice to Minister (2) A licensee who makes emergency alterations to a storage tank or a storage tank system under subsection (1) shall immediately give notice to

the Minister regarding the emergency alterations, including the following information:

- (a) the type of modification performed or to be performed;
- (b) when the modification is or will be performed;
- (c) the location of the storage tank or storage tank system;
- (d) the owner of the storage tank or storage tank system.

7. (1) Where, in the opinion of the Minister, a storage tank or storage tank system is not being, or has not been, installed or altered in accordance with the Act or these regulations, or in accordance with the conditions on the approval under subsection 5(2), the Minister may revoke the approval for installation or alteration of the storage tank or storage tank system by giving written notice of revocation to the owner.

Revocation of approval

(2) A notice of revocation under subsection (1) may be given by

*Idem*

- (a) personal service on the owner; or
- (b) by mail to the last known address of the owner as shown in the records of the Minister.

(3) A notice of revocation shall be effective

Effective date

- (a) on the date the owner is served with or receives the notice; or
- (b) 5 days after the date on which the notice is mailed,

whichever is earlier.

8. (1) A person who received an approval granted under clause 5(2)(a) shall provide notice to the Minister

Notice to Minister required

- (a) at least two working days prior to backfilling a newly installed or altered underground storage tank or storage tank system; and
- (b) on the completion of the installation or alteration of an aboveground storage tank or storage tank system.

(2) The Minister may cause an environment officer to inspect the storage tank or storage tank system in respect of which a notice was given under subsection (1).

Inspection

9. (1) Every Level 2 licensee shall, after completing an installation or alteration to a storage tank or storage tank system,

Certificate of Compliance

- (a) if satisfied that such storage tank or storage tank system complies with these regulations, complete and sign a Certificate of Compliance for the storage tank or storage tank system; and
- (b) provide the Minister with the Certificate of Compliance referred to in clause (a) within 4 working days of completion of the installation or alteration of the storage tank or storage tank system.

(2) Where the Minister receives a Certificate of Compliance under subsection (1), the Minister shall, in writing,

Written notice

- (a) approve the Certificate of Compliance if the Minister is satisfied that the installation or alteration of the storage tank or storage tank system complies with these regulations; or
- (b) reject the Certificate of Compliance if

	(i) an environment officer, after inspection under subsection 8(2) is of the opinion that the installation or alteration of the storage tank or storage tank system does not comply with these regulations; or (ii) in the opinion of the Minister, the Certificate of Compliance contains errors or omissions.
Copies of approval or rejection	(3) Copies of the approval or rejection of a Certificate of Compliance by the Minister under clause (2)(a) or (b) shall be provided to (a) the person who received an approval under clause 5(2)(a); and (b) the petroleum supplier listed in the application.
Form 4	(4) A Certificate of Compliance required by subsection (1) shall be completed on Form 4.
Non-compliant storage tank or system	<b>10.</b> (1) No person shall operate or cause to be operated a non-compliant storage tank or storage tank system.
Prior approval required	(2) No person shall (a) install or cause to be installed; or (b) alter or cause to be altered, a storage tank or storage tank system, unless (c) the installation is made in accordance with a valid approval under subsection 5(2); or (d) the installation or alteration was made under subsection 6(1).
No petroleum to be dispensed until approval	<b>11.</b> (1) Subject to subsection (3), no petroleum supplier shall dispense, or cause to be dispensed, petroleum into a newly installed or altered storage tank or storage tank system unless the petroleum supplier has received a copy of the approval of the Minister provided under clause 9(3)(b).
<i>Idem</i>	(2) No person shall dispense, or cause to be dispensed, petroleum into an underground storage tank for ballasting purposes unless the person has the written permission of the Minister or an environment officer to do so.
Approval to deliver petroleum	(3) The Minister may, on the written request of a level 2 licensee who installs or alters a storage tank or storage tank system, grant written approval to (a) a petroleum supplier to deliver petroleum to the newly installed or altered storage tank or storage tank system; and (b) the owner of such storage tank or storage tank system to operate the system in accordance with the approval, if (c) the petroleum supplier has not received a copy of the approval under clause 9(3)(b); and (d) the Minister is satisfied with the Level 2 licensee's determination that the storage tank or storage tank system is suitable for the storage and use of petroleum.
Expiry of approval	(4) An approval granted by the Minister under subsection (3) expires 30 days from the date of its issue.

(5) An approval granted by the Minister under subsection (3) includes permission to the owner to operate the storage tank or storage tank system for the delivery made under the permit. Permit includes permission to operate

(6) The petroleum supplier to which a 30 day approval was granted under subsection (3) shall not deliver to the storage tank or storage tank system after the approval has expired, unless the petroleum supplier has received a copy of the Minister's approval of the Certificate of Compliance granted under clause 9(2)(a). Certificate to be submitted before permit expires

#### UNDERGROUND STORAGE TANK STANDARDS

**12.** (1) Subject to this section, no person shall install an underground steel storage tank unless Installation of underground steel storage tank

(a) the storage tank

- (i) bears a metal nameplate that complies with section 5 of the Underwriter Laboratories of Canada ULC-S603-00 "Standards for Steel Underground Tanks for Flammable and Combustible Liquids", June 1985,
- (ii) installation complies with section 4.3 of the National Fire Code of Canada, and
- (iii) has impressed current cathodic protection; or

(b) the storage tank

- (i) bears a metal nameplate that complies with section 5 of the National Standard of Canada CAN/ULC-S603.1-03 "External Corrosion Protection Systems for Steel Underground Tanks for Flammable and Combustible Liquids",
- (ii) installation complies with
  - (A) Appendix B of CAN/ULC-S603.1-03 as described in subclause (i),
  - (B) section 4.3 of the National Fire Code of Canada, and
  - (C) the manufacturer's specifications, and
- (iii) has a permanent high impedance meter and zinc reference galvanic monitoring system complying with Underwriter Laboratories of Canada CAN/ULC-S603.1-03, Appendix A.

(2) No person shall install or operate an underground fibreglass storage tank unless such storage tank Installation of underground fibreglass storage tank

- (a) bears a metal label that complies with section 7 of the National Standard of Canada ULC-S615-98 "Reinforced Plastic Underground Tanks for Flammable and Combustible Liquids";
- (b) installation complies with section 4.3 of the National Fire Code of Canada; and
- (c) meets the manufacturer's specifications.

#### ABOVEGROUND STORAGE TANK STANDARDS

**13.** No person shall install a field-erected aboveground storage tank system unless it is designed and built in compliance with API 650-Welded Steel Tanks for Oil Storage. Field-erected aboveground storage tank

- Shop-fabricated aboveground storage tank
- 14.** No person shall install a shop-fabricated aboveground
- (a) horizontal storage tank unless it bears a metal label complying with section 4 of the National Standard of Canada ULC-S601-00, “Standard for Shop Fabricated Steel Aboveground Horizontal Tanks for Flammable and Combustible Liquids”; or
  - (b) vertical storage tank unless it bears a metal label complying with section 4 of the National Standard of Canada ULC-S630-00, “Standard for Shop Fabricated Steel Aboveground Vertical Tanks for Flammable and Combustible Liquids”.
- Installation complies with Codes
- 15.** No person shall install a shop-fabricated aboveground horizontal or vertical storage tank at a retail outlet, unless
- (a) such installation is made in accordance with the National Fire Code of Canada; and
  - (b) the location of the storage tank complies with the NFPA 30A Code for Motor Fuel Dispensing Facilities and Repair Garages 2003 Edition, as amended.
- Containment vault
- 16.** No person shall install an aboveground storage tank in a containment vault unless
- (a) the vault is made of precast concrete and is constructed in accordance with
    - (i) ULC/ORD-C142.15, “Precast Concrete Tanks for Flammable and Combustible Liquids”, or
    - (ii) the ASTM standard C-891-83 and the manufacturer’s specifications;
  - (b) the containment vault is equipped with a secure means of draining collected water from it; and
  - (c) each storage tank installed inside the containment vault
    - (i) has a minimum 30 cm clearance between the storage tank and the sidewalls of the chamber,
    - (ii) has a neoprene pad installed between the storage tank and concrete crib or cradle, and
    - (iii) is accessible for the measurement of petroleum levels for inventory control purposes.
- Secondary containment system
- 17.** (1) No person shall install an aboveground storage tank with a capacity of 2300 litres or greater without a secondary containment system.
- Volumetric capacity
- (2) Subject to subsection (3), the volumetric capacity of the containment system required in subsection (1) shall be
- (a) in the case of one storage tank, 110 percent of the petroleum storage capacity of the storage tank; or
  - (b) in the case of a multi-tank storage tank system, 110 percent of the petroleum storage capacity of the largest storage tank.
- Calculation of capacity
- (3) The containment capacity of the containment system required by subsection (1) shall be calculated after deducting the exterior displacement volume of the storage tanks, with the exception of the



largest storage tank, in order to allow for the displacement volume occupied by the storage tanks.

(4) Subsection (1) does not apply to double-walled aboveground storage tanks. Containment system exemption

**18.** No person shall install an aboveground storage tank or storage tank system Contact with ground

(a) in a manner that may result in such a storage tank or storage tank system being in contact with the ground, unless an adequate corrosion control system is installed at the same time to protect the portion of any storage tank that may be in contact with the ground; and

(b) unless such storage tank or storage tank system complies with the National Fire Code of Canada.

**19.** No person shall

(a) remove an underground storage tank, unless the person is the holder of a valid Level 1 or Level 2 Licence; or Removal or alteration of storage tank

(b) install or alter a storage tank or storage tank system, unless the person is the holder of a valid Level 2 Licence.

#### PIPING STANDARDS

**20.** (1) No person shall install underground metal piping and associated metal fittings for a storage tank unless such piping and fittings Underground installation

(a) are of a material type compatible with the contents of a storage tank;

(b) conform with the National Standard of Canada CAN/ULC-S603.1-03, "External Corrosion Protection Systems for Steel Underground Tanks for Flammable and Combustible Liquids"; and

(c) comply with the National Fire Code of Canada.

(2) No person shall install aboveground

(a) product piping or vent piping and associated fittings for a storage tank unless the installation Aboveground installation

(i) is made using steel of a type specified in the National Fire Code of Canada; and

(ii) complies with the National Fire Code of Canada; or

(b) rigid product piping for Class 1 liquid or diesel oil systems unless the rigid product piping begins and ends with a swing joint or a flexible connector.

(3) No person shall install non-metallic underground piping unless such piping Non-metallic underground piping

(a) conforms with ULC/ORD-C971-2005 "Non-metallic underground piping for flammable liquids";

(b) complies with the National Fire Code of Canada; and

(c) complies with the manufacturer's specifications.

## INVENTORY CONTROL

- Duties of operator of Class 1 storage tank system
- 21.** The operator of a Class 1 liquid or diesel fuel underground storage tank or storage tank system with a nominal capacity of 2000 litres or greater shall
- (a) maintain and reconcile inventory records for each day that the system is in operation;
  - (b) maintain monthly reconciliation summary sheets;
  - (c) retain the inventory records and summary sheets at the site of the storage tank or storage tank system for a minimum of two years; and
  - (d) immediately make such records and summary sheets available for inspection on the request of the Minister.
- Duties of operator of bulk sales outlet
- 22.** The operator of an aboveground storage tank or storage tank system at a bulk petroleum sales outlet shall
- (a) cause a visual inspection of the aboveground storage tank or storage tank system to be made for each day the aboveground storage tank or storage tank system is in operation to ensure that there is no damage or deterioration of the system that could result in a leak;
  - (b) maintain and reconcile weekly inventory records, and maintain annual reconciliation summary sheets;
  - (c) retain the inventory records and summary sheets made under clause (b) at the site of the bulk petroleum sales outlet for a minimum of five years; and
  - (d) immediately make inventory records and summary sheets available for inspection on the request of the Minister.

## REPORTING LEAKS OR LIQUID INTRUSION

- Duty to notify Coast Guard
- 23.** (1) The owner or operator of an underground storage tank or storage tank system to which section 21 or 22 applies shall immediately inform the Canadian Coast Guard at 1-800-565-1633 when inventory records or reconciliation summary sheets show any unaccounted-for petroleum loss or water gain.
- Inform Coast Guard of leak
- (2) Every person who has reason to believe that
- (a) petroleum is leaking or has leaked from a storage tank or storage tank system; or
  - (b) water or another liquid is intruding or has intruded into a storage tank or storage tank system
- shall immediately inform the Canadian Coast Guard at 1-800-565-1633.
- Leak detection test
- 24.** (1) Where, in the opinion of the Minister, petroleum leakage is occurring in a storage tank or storage tank system, the Minister may direct the owner to conduct a leak detection test on the storage tank or storage tank system.

(2) An owner who receives a directive under subsection (1) or clause 26(4)(b) shall Duties of owner

- (a) have the leak test conducted, at the owner's expense, by a testing agent acceptable to the Minister;
- (b) in the case of an underground storage tank or storage tank system, have the leak test conducted using a liquid-medium leak detection system capable of detecting 380 millilitres petroleum loss per hour; and
- (c) within three days of the leak test, forward to the Minister the written results of the leak test, certified by the testing agent.

(3) Where a leak test conducted under subsection (2) confirms that a storage tank or storage tank system is leaking petroleum, the owner shall Leak confirmed

- (a) immediately inform the Minister;
- (b) immediately empty the portion of the storage tank or storage tank system that is leaking petroleum;
- (c) arrange for a Level 2 licensee to investigate the leak; and
- (d) either
  - (i) repair the leak; or
  - (ii) immediately remove any storage tank that is leaking petroleum, in accordance with these regulations.

**25.** (1) The owner of a storage tank or storage tank system shall cause to be removed any subsurface contamination resulting from the operation of the storage tank or storage tank system by a method approved by the Minister in accordance with the *Environmental Protection Act* Petroleum Hydrocarbon Remediation Regulations (EC655/06) made under the Act. Removal of subsurface contamination

(2) Any costs associated with compliance with subsection (1) shall be the responsibility of the owner. Costs

#### STORAGE TANK UPGRADE AND MONITORING

**26.** (1) Subject to subsection (2), the owner of a sacrificial anode storage tank system shall ensure that regular maintenance checks are conducted on each such storage tank in the system by a corrosion specialist and comply with the National Standard of Canada CAN/ULC-S603.1-03, as follows: Regular maintenance checks

- (a) immediately after installation;
- (b) six months after installation;
- (c) annually thereafter.

- 
- Idem* (2) The owner of the sacrificial anode storage tank system may perform the maintenance checks required without the assistance of a corrosion specialist, if the storage tank system is equipped with a permanent high impedance meter and zinc reference galvanic monitoring system complying with Underwriter Laboratories of Canada CAN/ULC-S603.1-03, Appendix A.
- Notify Minister, cathode non-compliance (3) The owner of a sacrificial anode storage tank system or a corrosion specialist working on such a storage tank system shall immediately notify the Minister, in writing, if the owner or corrosion specialist determines that the cathodic protection does not comply with the CAN/ULC-S603.1-03 standard.
- Direction of Minister (4) Where the Minister has reason to believe that the owner of a sacrificial anode storage tank system is not complying with the maintenance checks required by subsection (1), the Minister may direct the owner to
- (a) immediately cause the removal of the storage tank system from the ground; or
  - (b) conduct a leak detection test on the storage tank system.
- Duties of owner (5) The owner of an impressed current storage tank system shall ensure that
- (a) maintenance checks are conducted on the system in compliance with the Petroleum Association for Conservation of the Canadian Environment PACE report No. 87-1, part 5.5(c) and part 6(a) and (c); and
  - (b) a corrosion specialist is contacted immediately, if
    - (i) the rectifier status lights indicate a problem, or
    - (ii) the controlled parameter charge has a reading greater than 10% of the normal operating condition.
- Notify Minister of non-conformance (6) The owner of an impressed current storage tank system shall immediately notify the Minister if the storage tank system does not conform to the PACE report No. 87-1 standard.
- Maintenance of records (7) The owner of a sacrificial anode storage tank system shall
- (a) maintain all records of maintenance checks at the site of the storage tank system for at least two years after the system is no longer in service; and
  - (b) on request, make such records immediately available to the Minister for inspection.

(8) The owner of an aboveground storage tank, with a capacity of 50,000 litres or greater shall ensure that inspections are conducted in conformance with the interval criteria in section 4.4.2 of API Standard 653.

Inspection interval  
criteria

27. An owner of a storage tank system where deficiencies are identified as a result of an inspection or maintenance check conducted under subsection 26(5) shall cause the storage tank system to be corrected by a corrosion specialist in compliance with the applicable provisions of the following standards:

Correction of  
deficiencies

- (a) technical supplement ULC-S601-00;
- (b) ULC-S630-00;
- (c) API Standard 653.

#### OUT-OF-SERVICE STORAGE TANKS

28. (1) Subject to subsection (2), the owner of a storage tank or storage tank system that is or will be out-of-service for a period of six consecutive months or more, shall immediately ensure that

Out-of-service  
storage tank system

- (a) the storage tank or storage tank system is emptied of all liquids and purged of all petroleum vapours in compliance with the NFPA 327 Standard (Standard for Safeguarding of Tanks and Containers for Entry Cleaning or Repair); and
- (b) the fill pipe and other openings are locked.

(2) The owner of an underground storage tank or storage tank system that requires ballast and that has been or will be out-of-service for a period of six months or more shall perform all maintenance to the tank or system required by these regulations during the out-of-service period.

Maintenance where  
ballast required

(3) The owner of an underground storage tank or storage tank system that is or will be out-of-service for a period of 12 consecutive months or more shall immediately

Out-of-service for  
12 months

- (a) notify the Minister, in writing, of the location of the storage tank or storage tank system;
- (b) ensure that the piping for the storage tank or storage tank system
  - (i) is removed from the ground, or
  - (ii) is purged of flammable vapours and petroleum, and is permanently sealed at each end of the piping by capping it,
- (c) remove the storage tank or storage tank system from the ground, and
- (d) remove any petroleum contaminated soil in accordance with the Petroleum Hydrocarbon Remediation Regulations.

---

Waiver of requirement	(4) The Minister may, on the written request of an owner, waive the requirement of clause (3)(c) for storage tanks that are deemed by an environment officer to be inaccessible.
Extension of waiver	(5) The Minister may, on the written request of an owner, extend the period of time in subsection (3) during which a storage tank or storage tank system may be out-of-service, for such period as the Minister may specify in writing.
Information regarding extension	(6) The owner of a storage tank or storage tank system who requests an extension of time under subsection (5) shall provide to the Minister, in writing, <ul style="list-style-type: none"><li>(a) the reason for requesting the extension;</li><li>(b) the length of the extension requested; and</li><li>(c) such other information that the Minister may require.</li></ul>
Bringing back into service	(7) No person shall bring a storage tank or storage tank system back into service unless the person <ul style="list-style-type: none"><li>(a) requests the approval of the Minister to bring the storage tank or storage tank system back into service;</li><li>(b) provides such information and performs such tests on the storage tank or storage tank system as the Minister may require; and</li><li>(c) receives the Minister's approval in writing to bring the storage tank or storage tank system back into service.</li></ul>
Site professional, defined	<b>29.</b> (1) In this section "site professional" means a site professional as defined in the Petroleum Hydrocarbon Remediation Regulations.
Removal of storage tank or system	(2) Where an underground storage tank or storage tank system is to be removed, <ul style="list-style-type: none"><li>(a) the owner shall notify the Minister of the proposed removal of such tank or system, at least five working days prior to the removal; or</li><li>(b) where the intended removal will be supervised by a site professional, the site professional shall submit a report to the Minister within 30 days of the removal,<ul style="list-style-type: none"><li>(i) providing information on the site in the manner set out in sections 2.0 and 3.0 of Schedule B of the Petroleum Hydrocarbon Remediation Regulations, and</li><li>(ii) indicating the impacts of petroleum hydrocarbons on the soil immediately adjacent to the removed storage tank or storage tank system.</li></ul></li></ul>

## STORAGE TANK DISPOSAL

- 30.** (1) Within three months of the removal of a storage tank under section 28, the owner of the storage tank shall Removal of underground storage tank
- (a) reinstall the storage tank in accordance with subsection 29(1);
  - (b) re-use the storage tank with the approval of the Minister under subsection 5(2); or
  - (c) dispose of the storage tank and its contents,
    - (i) at a disposal site approved by the Minister,
    - (ii) by a method approved by the Minister, or
    - (iii) by dismantling the storage tank on-site and disposing of the storage tank by a method approved by the Minister.
- (2) Where a storage tank will be disposed of under clause (1)(c), the owner shall, prior to removing the storage tank from the site Prior to disposal
- (a) cause the storage tank to be purged of petroleum and petroleum vapours by a Level 1 or Level 2 licensee, using a method approved by the Minister; and
  - (b) cause the storage tank to be certified as gas-free by a Level 1 or Level 2 licensee using an appropriate gas detection meter approved by the Minister.
- (3) The Minister may, on the request of the owner of a storage tank, extend the time period for performing the requirements of subsections (1) and (2). Extension of time
- (4) The owner of a storage tank requesting an extension under subsection (3) shall provide the Minister, in writing, with Information to be provided
- (a) the reason for requesting the extension;
  - (b) the length of the extension requested; and
  - (c) such other information as the Minister may require.

## GENERAL

- 31.** Upon the request of an environment officer, the owner of a storage tank or storage tank system, and the owner of the property upon which a storage tank or storage tank system is located shall Inspection
- (a) permit inspection of the storage tank or storage tank system by a licensee; and
  - (b) where necessary, uncover the storage tank or storage tank system to permit an inspection by an environment officer at the owner's expense.
- 32.** The forms referred to in these regulations are set out in Schedule A. Forms
- 33.** The *Environmental Protection Act* Petroleum Storage Tanks Regulations (EC322/01) are revoked. Revocation
- 34.** These regulations come into force on April 28, 2007. Commencement

## SCHEDULE A

**FORM 1**  
**APPLICATION TO INSTALL OR ALTER**  
**A STORAGE TANK OR STORAGE TANK SYSTEM**

Subsection 5(1) of the Petroleum Storage Tanks Regulations made under the *Environmental Protection Act* R.S. P.E.I. 1988 Cap. E-9 require a person to apply to the Minister for approval before installing or altering a storage tank or storage tank system. All applicable sections of this form must be completed.

Personal information on this form is collected under subsection 5(1) of the Petroleum Storage Tanks Regulations as it relates directly to and is necessary for an application to install or alter a storage tank or storage tank system. If you have any questions about this collection of personal information, you may contact the Director of Pollution Prevention Division, 11 Kent Street, Jones Building, Charlottetown, PE C1A 7N8, Phone: (902) 368-5474.

Storage Tank Owner and Facility Information		
Storage Tank Owner:	Phone:	
Contact Name:		
Mailing Address:		
Community:	Province:	Postal Code:
Physical Location of Storage Tank:		PID#:
Operator's Name (Retail Only):		

Applicant Contact Information (if different from above)		
Company Name:	Contact Name:	
Phone:	Fax:	
Mailing Address:		
Community:	Province:	Postal Code:

Storage Tank System Petroleum Supplier		
Company Name:	Contact Name:	
Phone:	Fax:	
Mailing Address:		
Community:	Province:	Postal Code:

Storage Tank System and Installation Information
Type of Storage Tank System: <input type="checkbox"/> Below Ground <input type="checkbox"/> Above Ground <input type="checkbox"/> Above Ground Retail
Application is for a: <input type="checkbox"/> New Installation <input type="checkbox"/> Alteration of Existing System
Proposed Date of Work:
Describe proposed work:

The application must include:

- Site plan complete with all major components (e.g. buildings, roadways, property lines, utilities, location of petroleum equipment)
- List of all proposed equipment to be installed or altered (e.g. storage tanks, piping, containment, dispensers, alarm systems)

Applicant Signature: \_\_\_\_\_

Date: \_\_\_\_\_



**FORM 2  
APPLICATION FOR PETROLEUM STORAGE TANK  
CONTRACTOR'S LICENCE**

Section 19 of the Petroleum Storage Tanks Regulations made under the *Environmental Protection Act* R.S.P.E.I. 1988, Cap. E-9, require a person to apply for a Petroleum Storage Contractor's Licence if the person intends to install, alter or remove petroleum storage tanks or petroleum storage tank systems.

Personal information on this form is collected under subsections 3(1) to (6) of the Petroleum Storage Tanks Regulations as it relates directly to and is necessary for an application for a Petroleum Storage Tank Contractor's Licence. If you have any questions about this collection of personal information, you may contact the Director of Pollution Prevention Division, 11 Kent Street, Jones Building, Charlottetown, PE C1A 7N8, Phone: (902) 368-5474.

Applicant Contact Information		
Name:	Company Name:	
Partners of Company (if applicable)		
Phone:	Fax:	
Mailing Address:		
Community:	Province:	Postal Code:

Level of Licence Applied For	
<input type="checkbox"/> Level 1 (Removals Only)	<input type="checkbox"/> Level 2 (Installing, Altering and Removing)

Applicant Experience
Describe successful completion of a relevant training program(s):

The application must include:

- A certificate of insurance coverage as required by clause 3(3)(b) of the regulations (for Level 2 applications only).

Applicant Signature: \_\_\_\_\_ Date: \_\_\_\_\_  
(Where applicant is a partnership or a corporation, the signature of a partner, or an authorized officer of the corporation)

The fee to apply for a Level 1 Petroleum Storage Tank Contractor's Licence is \$50.  
The fee to apply for a Level 2 Petroleum Storage Tank Contractor's Licence is \$100.

**Method of Payment**  
(Check appropriate box)

- Cheque
- Money Order
- Cash (hand delivery only)

**Amount Enclosed:** \$ \_\_\_\_\_

**Please forward application and payment to:**  
Department of Environment, Energy & Forestry  
Pollution Prevention Division  
PO Box 2000, 11 Kent Street  
Charlottetown, PE C1A 7N8  
Fax: (902) 368-5830

**Cheques and money orders should be made payable to the Provincial Treasurer.**



<b>Storage Tank Installation Details</b>	
Storage Tank Surface Inspection (Y/N) ____	Field Repairs _____
Storage Tank Test <input type="checkbox"/> Air <input type="checkbox"/> Liquid	Length of Test Hr ____ Min ____
Primary Test Results: PASS/FAIL	Observation Well? (Y/N) ____
Secondary Test Results: PASS/FAIL	
Type of Anchoring: <input type="checkbox"/> Deadman <input type="checkbox"/> Concrete Pad	
Backfill Material _____	Compaction? (Y/N) ____
Excavation Depth: _____ metres	Depth of Cover: _____ metres
<b>Piping Installation Details</b>	
Piping Manufacturer _____	
Pipe Trench Separation _____ metres	Pipe Slope 1/8" per foot? (Y/N) ____
Backfill Material _____	Compaction? (Y/N) ____
Pipe Separation _____ metres	Piping Isolated From Storage Tank? (Y/N) ____
Proper Swing Joint Construction? (Y/N) ____	
Piping Test: <input type="checkbox"/> Air <input type="checkbox"/> Liquid	Length of Test Hr ____ Min ____
Primary Test Results: PASS/FAIL	Proper Vent Height _____ metres
Secondary Test Results: PASS/FAIL	
<b>Alarm System installation Details</b>	
Alarm System Manufacturer _____	
Storage Tank Sump? (Y/N) ____	Dispenser Sump? (Y/N) ____
System Tested and Working? (Y/N) ____	
<b>On-Site Monitoring Station Details</b>	
Galvanic Monitoring Station? (Y/N) ____	Location of Station: _____
Number of Electrodes: _____	Proper Electrode Location? (Y/N) ____
Cathodic Protection Reading _____	Date of Reading (dd/mm/yy) _____
Vacuum Reading: Before: _____	After Installation: _____
<b>Contractor Information</b>	
Company Name: _____	Contact Name: _____
Phone: _____	Fax: _____
Mailing Address: _____	
Community: _____	Province: _____ Postal Code: _____
_____	_____
<b>Date</b>	<b>Signature</b>

**EXPLANATORY NOTES**

**SECTION 1** is the definition and application section.

**SECTION 2** provides that fees must be made payable to the Provincial Treasurer.

**SECTION 3** deals with licences, qualifications and renewals.

**SECTION 4** provides for the revocation of a licence by the Minister.

**SECTION 5** deals with an application to install or alter a storage tank or storage tank system and provides for the Minister to issue an approval of the application or to reject the application.

**SECTION 6** allows for an emergency alteration to a storage tank or storage tank system and requires notice to be given to the Minister.

**SECTION 7** provides for the revocation by the Minister of an approval granted under section 5.

**SECTION 8** requires a person who holds an approval to install or alter a storage tank or storage tank or storage tank system to provide notice to the Minister prior to backfilling a newly installed or altered underground storage tank system and of the completion of the installation or alteration of an aboveground storage tank or storage tank system..

**SECTION 9** requires a certificate of compliance to be submitted to the Minister and provides for approval or rejection by the Minister of the installation or alteration of a storage tank or storage tank system.

**SECTION 10** prohibits the operation of a storage tank or storage tank system that is non-compliant with the regulations and prohibits the construction or alteration of a storage tank or storage tank system without the written approval of the Minister.

**SECTION 11** prohibits the dispensing of petroleum into a newly installed storage tank or storage tank system without a copy of the approval of the Minister. The section also prohibits dispensing petroleum into an underground storage tank for ballasting purposes without the permission of the Minister or an environment officer. The Minister may issue 30-day permits.

**SECTION 12** deals with the installation of steel or fibreglass storage tanks underground.

**SECTION 13** prohibits the construction of a field-erected aboveground storage tank except in compliance with the standards of the National Standard of Canada.

**SECTION 14** prohibits the construction of a shop-fabricated aboveground storage tank except in compliance with the regulations.

**SECTION 15** deals with an aboveground shop-fabricated storage tank and compliance with the National Fire Code.

**SECTION 16** deals with standards applicable to an aboveground storage tank in a containment vault.

**SECTION 17** deals with a secondary containment system.

**SECTION 18** deals with contact with the ground and corrosion control.

**SECTION 19** makes it an offence for anyone other than a Level 1 or Level 2 licensee to remove an underground storage tank or storage tank system and an offence for anyone other than a Level 2 licensee to install or alter a underground storage tank or storage tank system.

**SECTION 20** deals with the requirements for the installation of underground and aboveground piping for storage tanks.

**SECTION 21** deals with inventory control of a large capacity underground storage tank system.

**SECTION 22** deals with the duties of the operator of a bulk sales outlet.

**SECTION 23** deals with a duty to notify the Coast Guard of a leak or unexplained water gain in a storage tank or storage tank system.

**SECTION 24** provides for a leak detection test.

**SECTION 25** deals with the removal of subsurface contamination.

**SECTION 26** deals with maintenance checks on a sacrificial anode storage tank or storage tank system and notification of the Minister on non-compliance or non-conformance.

**SECTION 27** requires corrections to be made to a storage tank or storage tank system that has identified deficiencies.

**SECTION 28** deals with out-of-service storage tanks or storage tank systems.

**SECTION 29** deals with the removal of an underground storage tank or system.

**SECTION 30** deals with the duties of an owner regarding an underground storage tank that has been removed from the ground and an extension of time granted by the Minister to fulfil those duties.

**SECTION 31** deals with inspections of storage tanks and storage tank systems.

**SECTION 32** provides for the forms referred to in these regulations to be set out in Schedule A.

**SECTION 33** revokes the prior regulations.

**SECTION 34** provides for the commencement of these regulations.

Certified a true copy,

W. Alexander (Sandy) Stewart  
Clerk of the Executive Council

---

**EC2007-241**

**ENVIRONMENTAL PROTECTION ACT  
HOME HEAT TANKS REGULATIONS**

(Approved by Her Honour the Lieutenant Governor in Council dated 17 April 2007.)

Pursuant to section 25 of the *Environmental Protection Act* R.S.P.E.I. 1988, Cap. E-9, Council made the following regulations:

Definitions	<b>1. (1)</b> In these regulations
Act	(a) “Act” means the <i>Environmental Protection Act</i> R.S.P.E.I. 1988, Cap. E-9;
alter	(b) “alter” means to repair, replace, upgrade, move or remove any part of a home heat tank system;
combustible tank stand	(c) “combustible tank stand” means any wooden stand that supports a home heat tank and does not meet a fire-resistance rating that is acceptable to the Fire Marshall or the Deputy Fire Marshall;
CSA	(d) “CSA” means the Canadian Standards Association;
Deputy Fire Marshall	(e) “Deputy Fire Marshall” means the person appointed as the Deputy Fire Marshall under clause 2(b) of the <i>Fire Prevention Act</i> R.S.P.E.I. 1988, Cap. F-11;

- (f) “double-bottom tank” means a primary tank that has  
 (i) an additional bottom capable of being pressurized, and  
 (ii) a means to monitor for leaks in the interstitial space between the two bottoms; double-bottom tank
- (g) “double-walled metallic tank” means a metallic home heat tank that is constructed with secondary containment and leak detection; double-walled metallic tank
- (h) “Fire Marshall” means the person appointed as the Fire Marshall under clause 2(c) of the *Fire Prevention Act*; Fire Marshall
- (i) “Holland College” means Holland College as established by subsection 2(1) of the *Holland College Act* R.S.P.E.I. 1988, Cap. H-6; Holland College
- (j) “home heat tank” means an aboveground petroleum storage tank forming a part of a home heat tank system that has a total capacity of 2200 litres or less, that is used to store petroleum for heating residential, commercial or other premises; home heat tank
- (k) “home heat tank system” includes  
 (i) a home heat tank, or  
 (ii) two or more home heat tanks and the piping connecting those tanks; home heat tank system
- (l) “identification tag” means an identification tag in the form required by Form 4 that is intended to be permanently affixed to a home heat tank; identification tag
- (m) “inside tank” means a home heat tank that is installed inside a building; inside tank
- (n) “inspector’s licence” means a home heat tank inspector’s licence issued under subsection 4(2); inspector’s licence
- (o) “installer’s licence” means a home heat tank installer’s licence issued under subsection 3(2); installer’s licence
- (p) “licensee” means a person who holds a valid installer’s licence or valid inspector’s licence; licensee
- (q) “manufacturer’s label” means a label by which a home heat tank manufacturer indicates compliance with the appropriate tank fabrication, and recognized testing agency standards; manufacturer’s label
- (r) “non-compliant”, in respect of a home heat tank or home heat tank system, means non-compliant with these regulations; non-compliant
- (s) “outside tank” means a home heat tank that is not installed inside a building; outside tank

owner	(t) “owner” means the person who owns, controls or manages a home heat tank system;
permanently affixed	(u) “permanently affixed” means affixed in such a way that an identification tag cannot be removed without destroying or rendering the identification tag as unusable;
petroleum	(v) “petroleum” means a mixture of petroleum hydrocarbons in liquid form, with or without additives, that is used or can be used as a combustible fuel for heating purposes;
prior regulations	(w) “prior regulations” means the Petroleum Storage Tanks Regulations (EC322/01) made under the Act;
product line protector	(x) “product line protector” means a device that provides protection from accidental breakage for the shut-off valve and fuel filter assembly of a home heat tank;
ULC	(y) “ULC” means Underwriters Laboratory of Canada;
vent pipe	(z) “vent pipe” means a pipe that is installed on a home heat tank to vent petroleum vapours to the atmosphere.
Application	(2) These regulations apply to home heat tanks and home heat tank systems.
Aboveground tanks	(3) For the purposes of these regulations, (a) an inside tank is aboveground if 100% of the volume of the inside tank is installed above the lowest level of the building in which the tank is installed; and (b) an outside tank is aboveground if 100% of the volume of the outside tank is installed above the ground surface, whether or not the piping associated with such tank is aboveground or underground.

#### LICENCES

Fees	<b>2.</b> The fees for an application for, or renewal of, a licence under these regulations shall be made payable to the Provincial Treasurer.
Application for an installer’s licence	<b>3.</b> (1) A person who wishes to install, alter or inspect home heat tanks or home heat tank systems shall apply for a home heat tank installer’s licence by (a) submitting a completed application to the Minister on Form 1; (b) providing such proof of the matters referred to in subsection (2) and such other information as the Minister may require; and (c) paying the application fee of \$50.



(2) The Minister may, on receipt of an application, issue a home heat tank installer's licence to an applicant, on Form 2, if the Minister is satisfied that the applicant

Licence,  
qualifications

- (a) is a holder of a valid trade certificate in the oil burner, sheet metal, refrigeration, air conditioning or plumbing trade;
- (b) has completed a home heat tank installer's course at
  - (i) Holland College,
  - (ii) a community college outside the province that the Minister considers to be equivalent to Holland College;
  - (iii) a private training school in the province licensed under the *Private Training Schools Act* R.S.P.E.I. 1988, Cap. P-20.1, or
  - (iv) a private training school outside the province that the Minister considers to be equivalent to a private training school referred to in subclause (iii),
- (c) is professionally competent as demonstrated by
  - (i) holding a current installer's licence or its equivalent in another jurisdiction in Canada, or
  - (ii) the successful completion by the applicant of such examination as may be established and administered, adopted or accepted by the Minister; and
- (d) has professional knowledge and skills that are current.

(3) An installer's licence issued under the prior regulations that was valid immediately before the date these regulations came into force is deemed to be an installer's licence issued under subsection (2).

Transitional

(4) The Minister may, on application, renew an installer's licence issued under subsection (2) to a person who holds the qualifications required by that subsection.

Renewal

(5) An installer's licence issued or renewed under this section expires on January 31 of the year following the date of the issue or renewal of the installer's licence.

Expiry

4. (1) A person who wishes to inspect home heat tanks or home heat tank systems shall apply for a home heat tank inspector's licence by
- (a) submitting a completed application to the Minister on Form 1;
  - (b) providing such proof of the matters referred to in subsection (2) and such information as the Minister may require; and
  - (c) paying the application fee of \$50.

Application for an  
inspector's licence

---

---

Licence, qualifications	<p>(2) The Minister may, on receipt of an application, issue a home heat tank inspector's licence to an applicant on Form 3, if after reviewing the application, the Minister is satisfied that the applicant</p> <ul style="list-style-type: none"><li>(a) has completed a home heat tank inspector's course at<ul style="list-style-type: none"><li>(i) Holland College,</li><li>(ii) a community college outside the province that the Minister considers to be equivalent to Holland College;</li><li>(iii) a private training school in the province licensed under the <i>Private Training Schools Act</i>, or</li><li>(iv) a private training school outside the province that the Minister considers to be equivalent to a private training school referred to in subclause (iii),</li></ul></li><li>(b) is professionally competent as demonstrated by<ul style="list-style-type: none"><li>(i) the successful completion within the previous two years of an oil burning equipment inspector program described in clause (a);</li><li>(ii) holding a current inspector's licence or its equivalent in another jurisdiction in Canada, or</li><li>(iii) the successful completion by the applicant of such examination as may be established and administered, adopted or accepted by the Minister; and</li></ul></li><li>(c) has professional knowledge and skills that are current, as indicated by the consideration by the Minister of<ul style="list-style-type: none"><li>(i) the recency of the applicant's educational qualifications,</li><li>(ii) the examination of the applicant under subclause (b)(iii),</li><li>(iii) the active practice of the applicant as an inspector, or</li><li>(iv) the taking of a refresher course, program or continuing education courses by the applicant that are acceptable to the Minister.</li></ul></li></ul>
Transitional	<p>(3) An inspector's licence issued under the prior regulations that was valid immediately before these regulations came into force is deemed to be an inspector's licence issued under subsection (2).</p>
Renewal	<p>(4) The Minister may, on application, renew an inspector's licence issued under subsection (2) to a person who holds the qualifications required by that subsection.</p>
Expiry	<p>(5) An inspector's licence issued or renewed under this section expires on January 31 of the year following the date of the issue or renewal of the inspector's licence.</p>
Revocation of licence	<p><b>5.</b> (1) Where, in the opinion of the Minister, a licensee has contravened the Act or these regulations the Minister may revoke the installer's licence or inspector's licence held by the licensee.</p>
Notice of revocation	<p>(2) The Minister shall give written notice of the revocation of a licence under subsection (1) to the licensee by</p> <ul style="list-style-type: none"><li>(a) personal service; or</li></ul>

(b) by registered mail to the last known address of the licensee as shown in the records of the Minister.

(3) A notice sent by registered mail under clause (2)(b) shall be deemed to be served on the licensee Service

(a) on the date the licensee actually receives the notice; or

(b) 5 days after the date on which the notice was mailed, whichever is earlier.

6. Every licensee who Inspection

(a) installs a home heat tank system; or

(b) alters, moves or relocates a home heat tank system,

shall carry out a home heat tank system inspection immediately after completing the installation, alteration, move or relocation.

7. (1) A licensee who installs, alters or inspects a home heat tank system shall ensure that the home heat tank system, as installed Compliance with standards, etc.

(a) complies with the

(i) "Construction Standards for the Installation of Aboveground Home Heat Tank Systems" as described in Schedule B, if the tank was installed on or after March 1, 2004,

(ii) "Standard for the Inspection and Tagging of Home Heat Tank Systems on PEI With a Total Capacity of 2,200 Litres or Less for Home Heat Tanks Installed Prior To March 2004" as described in Schedule C if the tank was installed prior to March 1, 2004,

(iii) Water Well Regulations (EC188/90) made under the Act,

(iv) CSA B139-04 Installation Code For Oil-Burning Equipment,

(v) CAN/ULC-S642-87(R2000) Compounds and Tapes for Threaded Pipe Joints,

(vi) National Fire Code of Canada 1995 Revised 2002,

(vii) CAN/ULC S602-03 Aboveground Steel Tanks for the Storage of Combustible Liquids Intended to be Used as Heating and/or Generator Fuels,

(viii) CAN/ULC S643-00 Aboveground Shop Fabricated Steel, Utility Tanks,

(ix) ULC/ORD-C80.1-00 Aboveground Non-Metallic Tanks for Fuel Oil; or

(x) any other method approved by the Minister; and

(b) bears the manufacturer's label.

(2) Every person who installs a home heat tank shall ensure that such tank was built in conformance with the following codes, as amended: Metallic tank, codes

(a) ULC ORD-142.5-1992 Aboveground Rectangular Steel Tanks;

(b) ULC ORD-142.21-1995 Used-Oil Systems, Aboveground Storage Tanks for Flammable and Combustible Liquids;

(c) ULC ORD-142.22-1995 Contained Vertical Steel Aboveground Tank Assemblies for Flammable and Combustible Liquids;

(d) ULC-S601-2000 Standard for Shop Fabricated Steel Aboveground Horizontal Tanks for Flammable and Combustible Liquids;

- (e) CAN/ULC-S602-03 Aboveground Steel Tanks for Fuel Oil and Lubricating Oil;
- (f) ULC-S630-2000 Tanks Aboveground, Vertical, Shop Fabricated Steel for Flammable and Combustible Liquids;
- (g) CAN/S653-1994 Aboveground, Shop Fabricated Steel, Utility Tanks;
- (h) ULC/ORD-C80.1-2000 Standard for Aboveground Non-Metallic Tanks for Fuel Oil.

Inspection report,  
ID tag, etc.

(3) Where a licensee completes a home heat tank system inspection and is satisfied that the home heat tank system complies with the requirements of subsections (1) and (2), the licensee shall

- (a) complete an identification tag in Form 4;
- (b) calculate the expiry year
  - (i) for a single tank by referring to Schedule D, and
  - (ii) for more than one tank in a multiple tank system by referring to Schedule D in respect of the oldest tank in the system;
- (c) ensure that the expiry month and year for which the identification tag is completed is single stamped and legible on the identification tag using a numerical stamping tool;
- (d) complete an inspection report on Form 5 for each tank on which an identification tag was permanently affixed;
- (e) permanently affix the identification tag to the vent pipe of the tank identified in the inspection report
  - (i) as close as may be practicable to the intake fill pipe and in prominent view, by riveting or some other method approved by the Minister, and
  - (ii) in such a manner that the identification tag is rendered unusable if removed; and
- (f) submit a copy of the inspection report immediately
  - (i) to the owner, and
  - (ii) to the employer of the licensee, if any.

Removal of old tag

(4) The licensee who affixes the tag under clause (3)(e) shall remove any existing identification tags from the home heat tank and forward them to the Department.

Notification,  
reports, submitted  
to Minister

**8.** A self-employed licensee, and an employer of a licensee, shall submit copies of the inspection reports required under clause 7(3)(d) to the Minister not later than 5 business days after the end of the month in which the inspection was made.

ID tags issued to  
employer

**9.** (1) The Minister shall, at the written request of

- (a) a self-employed licensee; or
- (b) an employer who employs licensees,

issue identification tags to such licensee or employer.

Refusal to issue tags

(2) The Minister may refuse to issue identification tags to a self-employed licensee or an employer of a licensee, if the Minister believes

that the licensee or employer, as the case may be, has not submitted inspection reports as required by section 8.

(3) An employer who is issued tags under subsection (1), Assignment of ID tags by employer  
 (a) shall assign the identification tags only to employees who hold a valid installer's or inspector's licence;  
 (b) shall maintain a record of which identification tags are assigned to each employee; and  
 (c) may re-assign any identification tag to another employee who holds a valid installer's or inspector's licence.

(4) A record of identification tags kept under clause (3)(b) shall be Records of id tags  
 (a) maintained by a licensee or employer for at least two years from the date they are issued by the Minister; and  
 (b) made available to an environment officer on the request of such officer.

(5) Every person whose installer's licence or inspector's licence has expired and has not been renewed, or has been revoked, by the Minister shall return all unused identification tags to the Minister within 10 working days from the date of expiry or revocation. Return of ID tags by licensee whose licence expires

(6) An employer who no longer employs licensees shall return all unused identification tags to the Minister within 10 working days of ceasing to employ licensees. Employer returns tags

(7) An identification tag is no longer valid if the identification tag is removed from ID tag no longer valid  
 (a) the property where it was first permanently affixed to a home heat tank vent pipe; or  
 (b) the home heat tank system where it was permanently affixed.

**10.** Where a licensee discovers that a home heat tank system was not installed in accordance with these regulations and has an affixed identification tag, the licensee shall immediately notify the Minister of the particulars of the non-compliant home heat tank system. Non-compliant tank with tag

**11.** No person shall, except in accordance with subsection 9(3), Sale transfer of ID tags  
 (a) give or transfer an identification tag to another person;  
 (b) sell an identification tag; or  
 (c) alter, re-use, remove or attempt to alter, remove or re-use an identification tag that has been permanently affixed to a home heat tank system.

**12.** (1) Subject to subsection (2), no person shall install, alter or remove any part of a home heat tank system unless the person holds an installer's licence. Licence required to install

(2) An owner may install a product line protector or a fuel gauge protector on or near a home heat tank. Exception

---

Sale of home heat tanks	<b>13.</b> (1) No person shall sell, or offer to sell, a home heat tank to any other person unless the other person holds a valid installer's licence.
Exception	(2) Subsection (1) does not apply to a wholesaler who sells home heat tanks to a retailer for the purpose of resale.
No home delivery, when	<b>14.</b> (1) No person shall deliver petroleum to an outside home heat tank system if <ol style="list-style-type: none"><li>the tank<ol style="list-style-type: none"><li>has a shut-off valve or a fuel filter assembly that is not installed directly under the tank, or</li><li>is not equipped with a product line protector; or</li></ol></li><li>the tank has a combustible tank stand.</li></ol>
Sept. 1, 2007	(2) After September 1, 2007, no person shall deliver petroleum to a home heat tank where such tank is non-compliant for any of the following reasons: <ol style="list-style-type: none"><li>there is no identification tag permanently affixed to the vent pipe;</li><li>the identification tag has no tank expiry date stamped on it;</li><li>the tank expiry date stamped on the identification tag has been reached;</li><li>the person has reason to believe that the identification tag has been altered;</li><li>the person has reason to believe that the identification tag affixed to the vent pipe was not issued by the Minister.</li></ol>
Exception	(3) Notwithstanding clause (2)(a), where an identification tag is not permanently affixed to a home heat tank vent pipe, a person may deliver petroleum to that tank if the person obtains oral confirmation from an environment officer that the person may do so.
Notice to owner and Minister	(4) Where a person is prohibited by this section from delivering petroleum to a home heat tank, the person or the person's employer shall <ol style="list-style-type: none"><li>immediately give notice to the owner that<ol style="list-style-type: none"><li>the tank does not have an identification tag or the identification tag does not comply with these regulations; and</li><li>the person is prohibited by these regulations from delivering petroleum to that home heat tank; and</li></ol></li><li>report the person's finding to the Minister within one working day of discovering that the home heat tank is non-compliant in accordance with subsection (2).</li></ol>
Leaking tank	<b>15.</b> (1) Every person who has reason to believe that petroleum is leaking or has leaked from a home heat tank system shall immediately <ol style="list-style-type: none"><li>notify the owner of the home heat tank system; and</li><li>report the leak by telephoning the Canadian Coast Guard at 1-800-565-1633.</li></ol>
Duty of owner	(2) Upon receiving a notification under subsection (1), the owner shall immediately cause the system to be taken out of service until the home

heat tank system is replaced or repaired in accordance with these regulations.

- 16.** The owner of a double-walled or double-bottom metallic tank shall
- (a) ensure that the tank has an operational leak detecting device; and
  - (b) immediately notify the Department if such device indicates that there is a petroleum leak within the interstitial space.
- Double-walled  
metallic tank
- 17.** At an environment officer's request, the owner of a home heat tank system, and the owner or person in possession of the property on which the home heat tank system is located, shall permit access by the environment officer to the home heat tank system.
- Access by  
environment officer
- 18.** (1) Where, in the opinion of an environment officer, a home heat tank system does not comply with these regulations, the environment officer may remove, or request an installer to remove, the identification tag and submit the identification tag to the Minister.
- Non-compliant  
home heat tank  
system
- (2) The Minister shall send written notification of the removal of the identification tag to the owner of the home heat tank system not later than the next working day following the day that the identification tag is received by the Minister.
- Notice to owner
- 19.** Where a home heat tank system has reached its expiry date as indicated on Form 5, the owner of the home heat tank shall replace or remove the home heat tank not later than the month in which the inspection was completed, as shown on Form 5.
- Replacement of  
expired tank
- 20.** Every owner of a home heat tank system shall ensure that
- (a) the home heat tank system is inspected and tagged in accordance with section 7; or
  - (b) the home heat tank system is upgraded or replaced and tagged in accordance with these regulations,
- on or before September 1, 2007.
- Inspection,  
upgrading deadline
- 21.** Where a home heat tank is replaced by a licensee, the licensee performing the replacement shall ensure that no water or sludge contamination is transferred from the home heat tank system to the new tank.
- No water or sludge  
transfer from old  
tank
- 22.** The forms and schedules referred to in these regulations are set out in the Schedule.
- Forms
- 23.** These regulations come into force on April 28, 2007.
- Commencement

## SCHEDULE

## SCHEDULE A – FORMS

**FORM 1**  
**APPLICATION FOR INSTALLER'S**  
**OR INSPECTOR'S LICENCE**

The Home Heat Tanks Regulations made under the *Environmental Protection Act* R.S.P.E.I. 1988, Cap. E-9 require a person to apply for an installer's licence if the person intends to install, alter, remove, inspect or affix identification tags to home heat tank systems (s. 3) or an inspector's licence if the person intends to inspect and affix identification tags to home heat tank systems (s. 4).

Personal information on this form is collected under subsections 3(1) and 4(1) of the Home Heat Tanks Regulations as it relates directly to and is necessary for an application for an installer's licence or an inspector's licence. If you have any questions about this collection of personal information, you may contact the Director of Pollution Prevention Division, Home Heat Tank Program, 11 Kent Street, Jones Building, Charlottetown, PEI C1A 7N8, Phone: (902) 368-5474.

Applicant Contact Information		
Name:	Company Name:	
Partners of Company (if applicable)		
Phone:	Fax:	
Mailing Address:		
Community:	Province:	Postal Code:

Type of Licence Applied For
<input type="checkbox"/> installer's licence (installing, altering, removing and inspecting)
<input type="checkbox"/> inspector's licence (inspections only)
<input type="checkbox"/> New Applicant <input type="checkbox"/> Renewal of Licence Present Licence Number:

Applicant Experience
Describe successful completion of a relevant training program(s) (include dates):
Describe experience in inspecting and installing (if applicable) home heat tank systems (e.g. number of installations and/or inspections in the past year):

Applicant Signature: ..... Date: .....  
 (Where applicant is a partnership or a corporation, the signature of a partner, or an authorized officer of the corporation)



The fee to apply for an installer's or inspector's licence is \$50.

<p><b>Method of Payment</b> (Check appropriate box)</p> <p><input type="checkbox"/>Cheque</p> <p><input type="checkbox"/>Money Order</p> <p><input type="checkbox"/>Cash (hand delivery only)</p> <p><b>Amount Enclosed: \$.....</b></p>	<p><b>Please forward application and payment to:</b> Department of Environment, Energy &amp; Forestry Pollution Prevention Division Home Heat Tank Program PO Box 2000, 11 Kent Street Charlottetown, PE C1A 7N8 Fax: (902) 368-5830</p>
--	--

**Cheques and money orders should be made payable to the Provincial Treasurer.**

<b>FORM 2 INSTALLER'S LICENCE</b>	
<p style="text-align: center;">Prince Edward Island Environment, Energy and Forestry</p> <p style="text-align: center;"><b>Home Heat Tank Installer's Licence</b></p> <p style="text-align: center;">Pursuant to section 3 of the <i>Environmental Protection Act</i> Home Heat Tanks Regulations</p>	<p style="text-align: center;">LICENSEE</p> <p>Surname: _____ Given Name: _____</p> <p>Issue Date: _____ Expiry Date: _____</p> <p>The person named herein is licensed to install, alter, inspect, remove and affix tags to home heat tank systems pursuant to the <i>Environmental Protection Act</i> Home Heat Tanks Regulations.</p>
Licence Number: _____	Authorized Signature: _____

<b>FORM 3 INSPECTOR'S LICENCE</b>	
<p style="text-align: center;">Prince Edward Island Environment, Energy and Forestry</p> <p style="text-align: center;"><b>Home Heat Tank Inspector's Licence</b></p> <p style="text-align: center;">Pursuant to section 4 of the <i>Environmental Protection Act</i> Home Heat Tanks Regulations</p>	<p style="text-align: center;">LICENSEE</p> <p>Surname: _____ Given Name: _____</p> <p>Issue Date: _____ Expiry Date: _____</p> <p>The person named herein is licensed to inspect and affix tags to home heat tank systems pursuant to the <i>Environmental Protection Act</i>, Home Heat Tank Regulations.</p>
Licence Number: _____	Authorized Signature: _____

**FORM 4  
IDENTIFICATION TAG**

<p>PEI ABOVEGROUND OIL TANK I.D. TAG</p> <p>XXXXXX 20__</p>
---

**FORM 5  
INSPECTION REPORT**

**Homeowner Information**

Full Name .....

Civic # ..... Street/Road Name or Route # .....

Community ..... Postal Code ..... Telephone .....

**Installer/Inspector Information**

Installer/Inspector Name .....

Company .....

**Inspection Information**

Type of Inspection:  
 Routine  Replacement  Alteration  New Home

Date of Inspection: ...../...../..... (month/day/year)

PEI Aboveground Tank ID Tag # .....

Tank Location: Outdoors  In Basement  Other (specify) .....

Piping Type: Bottom Outlet  End Outlet  Top Feed

Tank Gauge: 14 Gauge  12 Gauge  Non-Corrosive

Tank Year of Manufacture ..... Tank Expiry Date .....

ULC Serial Number .....

**Passed Inspection** Yes  No

I certify that the home heat tank system described in this report has been inspected by me and is installed in accordance with the requirements of the *Environmental Protection Act*, and the Construction Standards for Installation of Aboveground Home Heat Tank Systems.

Inspector's Signature .....

**Comments** .....

.....

.....

.....

.....

**SCHEDULE B****CONSTRUCTION STANDARDS  
FOR THE INSTALLATION OF  
ABOVEGROUND HOME HEAT  
TANK SYSTEMS****Section 1.0 General**

## Section 1.1

This standard is intended to highlight the mandatory installation requirements for all home heat tank systems installed in the Province of Prince Edward Island after March 2004. It is intended to be used in conjunction with the CSA B139-04 Installation Code For Oil-Burning Equipment, CAN/ULC S643-00 Aboveground Shop Fabricated Steel, Utility Tanks and CAN/ULC S602-03 Aboveground Steel Tanks for the Storage of Combustible Liquids Intended to be Used as Heating and/or Generator Fuels. For the purposes of installing home heat tanks on Prince Edward Island, any differences between the B139-04, CAN/ULC S602-03, and S643-00 codes and these standards, these standards shall prevail.

## Section 1.2

Home heat tanks shall not be reused except with the oral permission of the Minister.

**Section 2.0 Installation of Outside Tanks**

## Section 2.1

It is the responsibility of a home heat tank installer to ensure that outside home heat tanks or systems are installed in accordance with all applicable codes and regulations in force at the time of installation and in accordance with Figures 1, 2 and 3. The installer shall ensure that:

- (a) a prepared support base is constructed by removing a minimum of 150 mm (6 in) of top soil and replacing it with an equal amount of tamped sand, clean gravel, or poured concrete;
- (b) the support base is situated at least 1.5 meters (5 ft) from a property line, wherever feasible;
- (c) two re-enforced 750mm x 750mm (30 in x 30in) patio stones are placed level on the tamped sand or gravel (*pressure-treated wood material can be used under the tank legs provided that it is below grade and in contact with the ground. The top surface may be exposed*);
- (d) four tank support legs are centred on the reinforced patio stones or concrete pad ensuring the bottom of the tank is between 100 mm (4 in) and 300 mm (12 in) off the support base;
- (e) product line and fuel gauge protectors are installed except where no portion of the valve or filter protrudes from underneath the tank;
- (f) a horizontal vibration loop is placed as close as possible to the shut-off valve;
- (g) wherever feasible, the product line maintains a continuous downward slope from the tank to the building;
- (h) wherever feasible, the fuel filter is located inside the building;
- (i) tanks are equipped with a working vent whistle and fuel gauge;
- (j) piping and tubing run as directly as practicable and provisions made for expansion, contraction, jarring, vibration, and settling;
- (k) piping and tubing is substantially supported and protected against physical damage;
- (l) two or more cross connected tanks are installed on a common poured cement pad;  
and
- (m) cross connected tanks are installed in accordance with section 14 of this standard.

**Figure 1. Installation Diagram for Outside Tanks**

- A1 Concrete pad or reinforced patio stone
- A2 150 mm (6 in) tamped sand or clean gravel  
replacing 150mm (6 in) of topsoil
- A3 Horizontal vibration loop
- A4 Product line protector
- A5 Fuel gauge and gauge protector
- A6 Fill pipe, vent pipe, vent whistle

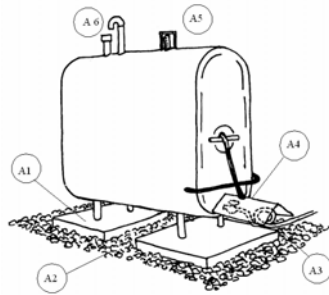
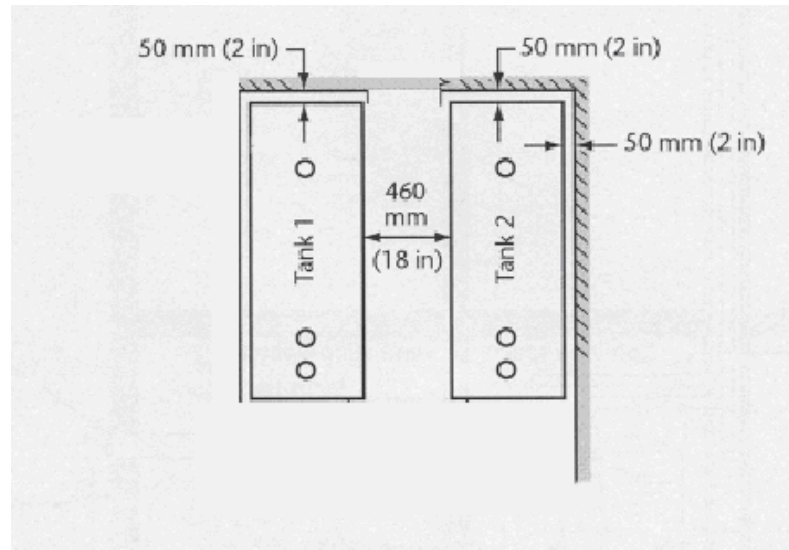
**Figure 2 Fuel Clearance Values for the Installation of Multiple Outside Tanks**

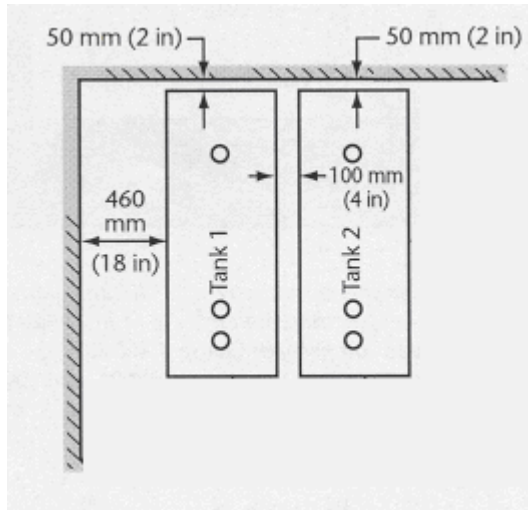
**Figure 3 Fuel Clearance Values for the Installation of Multiple Outside Tanks****Section 3.0 Installation of Inside Tanks**

It is the responsibility of a home heat tank installer to ensure that inside home heat tank systems are installed in accordance with all applicable codes and regulations in force at the time of installation and in accordance with Figures 4, 5, 6 and 7. The installer shall ensure that:

- (a) there is a minimum of 460 mm (18 in) clearance along one side and one end of the tank;
- (b) there is a minimum of 50 mm (2 in) clearance from any portion of the tank to a wall;
- (c) sufficient clearance is provided to allow the temporary repair of any tank underside;
- (d) tanks do not impede exit from the building;
- (e) the horizontal distance from the tank to a petroleum fuel-fired appliance is at least 600 mm (2 ft);
- (f) the horizontal distance from the tank to a solid fuel fired appliance is at least 1500 mm (5 ft);
- (g) no portion of the tank prevents 900 mm (3 ft) clear access to an electrical panel;
- (h) fill and vent pipes terminate to the open air; and
- (i) tanks are equipped with a working vent whistle and fuel gauge.

**Figure 4. Installation Diagram for Inside Tanks**

- A - Concrete flooring
- B - Vent whistle
- C - Vent pipe to outside
- D - Fill pipe to outside
- E - Fuel gauge

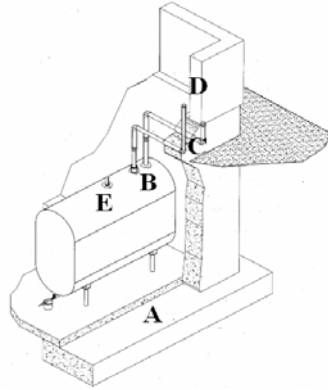
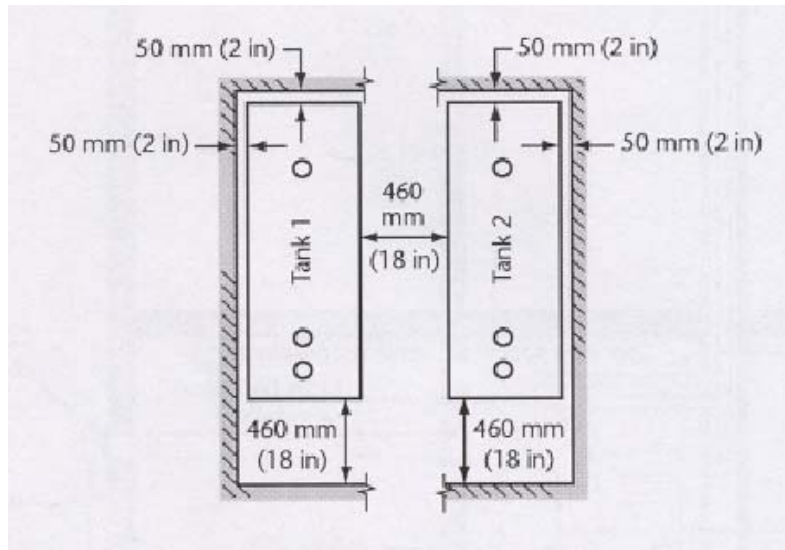
**Figure 5 Fuel Clearance Values for the Installation of Multiple Inside Tanks**

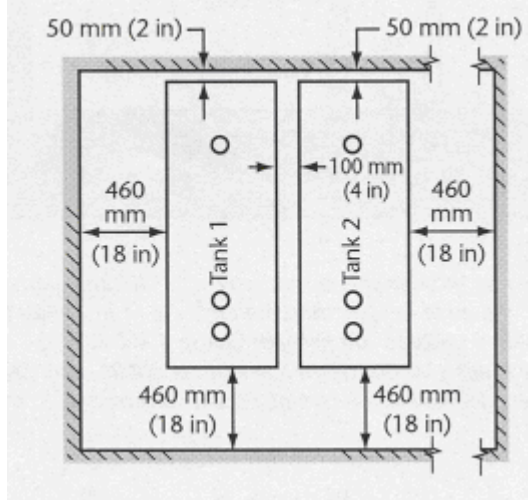
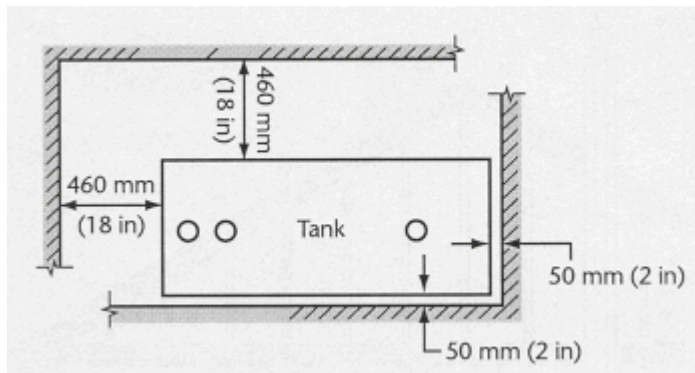
**Figure 6 Fuel Clearance Values for the Installation of Multiple Inside Tanks****Figure 7 Fuel Clearance Values for Single Inside Tank Installations****Section 4.0 Fill Pipe Connections**

## Section 4.1

Fill pipes shall be installed in accordance with the requirements of all applicable codes and regulations at the time of installation.

## Section 4.2

Fill pipes shall be not less than 50 mm (2 in) in diameter.

## Section 4.3

The opening to a fill pipe shall terminate:

- (a) not less than 200 mm (8 in) above the outside elbow of an inside installation;
- (b) as close as possible to the tank for an outside installation;
- (c) not less than 600 mm (2 ft) from any building opening;

- (d) not less than 900 mm (3 ft) from an air intake; and
- (e) not less than 900 mm (3 ft) above ground level.

### Section 5.0 Vent Pipe Connections

#### Section 5.1

Vent pipes shall be installed in accordance with the requirements of all applicable codes and regulations at the time of installation.

#### Section 5.2

Vent pipes shall terminate at least 150 mm (6 in) above the opening to a fill pipe.

#### Section 5.3

Single tanks having a capacity of 1250 litres (275 gal) or less capacity shall have vent pipes which correspond to the following chart.

Equivalent Length	Vent Pipe Diameter ID, mm (in)
up to 7.6 m (25 ft)	32 mm (1 ¼ in)
over 7.6 to 15.2 m (over 25 ft to 50 ft)	38 mm (1 ½ in)
over 15.2 m to 30.5 m (over 50 ft to 100 ft)	50 mm (2 in)
over 30.5 m (over 100 ft)	to be accepted by a professional engineer

*Note:*

*One 32 mm (1¼ in) 90° elbow has an equivalent length of 1.0 meter (3 ½ ft) of straight 32 mm (1¼ in) pipe.*

*One 38 mm (1½ in) 90° elbow has an equivalent length of 1.2 meters (4 ft) of straight 38 mm (1½ in) pipe.*

*One 50 mm (2 in) 90° elbow has an equivalent length of 1.5 meters (5 ft) of straight 50 mm (2 in) pipe.*

#### Section 5.4

Single tanks with a capacity greater than 1250 litres but less than 2200 litres shall have vent pipes not less than 50 mm (2 in).

#### Section 5.5

Cross-connected tanks shall have 50mm (2 in) separate vent pipes, or 75 mm (3 in) manifold vents as prescribed in Figures 3 and 4, or as supplied by the tank manufacturer. A vent whistle shall be connected to the vent pipe on the same tank to which the fill pipe is connected.

#### Section 5.6

Vent pipes shall not be cross-connected with fill pipes or with fuel oil return lines from burners.

#### Section 5.7

The opening to a vent pipe shall terminate close to the building wall and:

- (a) not less than 150 mm (6 in) above a fill pipe;
- (b) not less than 600 mm (2 ft) from any building opening; and
- (c) not less than 900 mm (3 ft) from an air intake.



**Section 6.0 Product Lines**

## Section 6.1

The product line from the tank to the appliance burner shall be replaced whenever a new home heat tank is installed.

## Section 6.2

When any portion of a product line runs below a foundation wall, under a floor, or under the ground, it shall be a continuous length of poly-coated non-corrosive copper tubing approved for fuel oil use. This coated product line shall be placed inside a second continuous length of tubing with both ends of the second length of tubing protruding a minimum of 50 mm (2 in) above ground/floor level.

**Section 7.0 Testing of New or Replacement Tanks**

When installing a single-wall home heat tank system, the installer shall test the tank connections for leaks by means of a pneumatic test, or a hydrostatic test during first filling.

**Section 8.0 Piping and Tubing**

## Section 8.1

All piping and tubing shall be new and shall be standard-weight wrought iron, steel, or brass pipe; or brass, copper, or steel tubing.

## Section 8.2

Fill or vent pipes shall be steel or galvanized construction. Galvanized pipes, except as fill or vent pipes on storage or supply tanks, shall not be used when exposed to heat or for conveying preheated fuel oil.

## Section 8.3

Flexible metal hose may be used when rigid connections are impracticable, or when required to reduce the effect of jarring or vibration. Such hose shall be of a type certified for the application and shall be installed strictly in accordance with the approval for the appliance.

## Section 8.4

Joints and connections shall be made with standard pipe fitting or by welding.

## Section 8.5

Cast iron fittings shall not be used.

## Section 8.6

A joint in seamless copper, brass, or steel tubing shall be made by means of a flare joint or approved fitting, or shall be brazed with a material having a melting point exceeding 540°C (1000°F).

## Section 8.7

Compression fittings shall not be used.

**Section 8.8**

Threaded joints in the vent and fill piping shall be made fuel-oil tight using joint compound or polytetrafluorethylene tape approved for use with fuel oil.

**Section 9.0 Shut-off Valves**

A shut-off valve shall be installed in the fuel line as near as practicable to the supply tank, and at such other locations as may be required to avoid spillage during servicing. Shut-off valves shall be:

- (a) of the manual type;
- (b) readily accessible;
- (c) installed to close against the supply of fuel oil;
- (d) substantially protected against physical damage; and
- (e) certified for its intended use.

**Section 10.0 Fuel Oil Filters**

A suitable fuel oil filter or strainer assembly shall be provided in the fuel supply line to the appliance or equipment, and shall be located inside the building where the appliance or equipment is located, wherever feasible.

**Section 11.0 Tank Stands****Section 11.1**

Wooden tank stands are permitted for outside installations if constructed using a minimum of 4x4 pressure treated wood for the posts and saddle. These posts must extend high enough on both sides to keep the tank from falling out. The four saddle pieces holding the tank in place shall be a minimum of 4x4 pressure treated wood and bolted together with the four posts. Additional support/cross pieces can be 2x6 pressure treated wood or larger, however, they shall be bolted together using a nut and washer. Except for the tank leg brackets and pipe legs, no portion of the tank shall rest on the wooden stand.

**Section 11.2**

Steel tank stands shall be constructed using a minimum of two inch tubular steel posts or other material as approved by the Minister. These posts must extend high enough on both sides to keep the home heat tank from falling out. The four saddle pieces holding the tank in place shall also be a minimum of two inch square tubular steel. Except for the pipe legs, no portion of the tank shall rest on the steel stand.

**Section 12.0 Distance from a Well (New Home Construction)**

No person shall construct, or permit to be constructed, a home heat tank system that is

- (a) 1,200 litres (265 gal.) or less in size, within 5 meters (16 ft) of a well; or
- (b) greater than 1,200 litres in size, within 15 meters (48 ft) of a well.

**Section 13.0 PEI Aboveground Tank I.D. Tag**

A PEI Aboveground Tank I.D tag shall be attached to the outside vent pipe by the installer as part of the installation process by means of rivets or other methods approved in writing by the Minister.

### Section 14.0 Cross Connected Tanks

Figures 3 to 6 illustrates the acceptable connection arrangements for cross connected multiple tanks.

#### Section 14.1

Cross-connect steel tanks with separate vents shall be installed as outlined in Figure 8 and shall include the following specifications:

- (a) fill and vent pipes shall be a 50 mm (2 in) pipe;
- (b) shut-off valves (V) shall be installed for each tank;
- (c) the cross connecting pipe (CP) shall be a 50 mm (2 in) pipe and substantially supported; and
- (d) both tanks shall be installed on a common slab.

**Figure 8 Cross-Connected Tanks with Separate Vents**

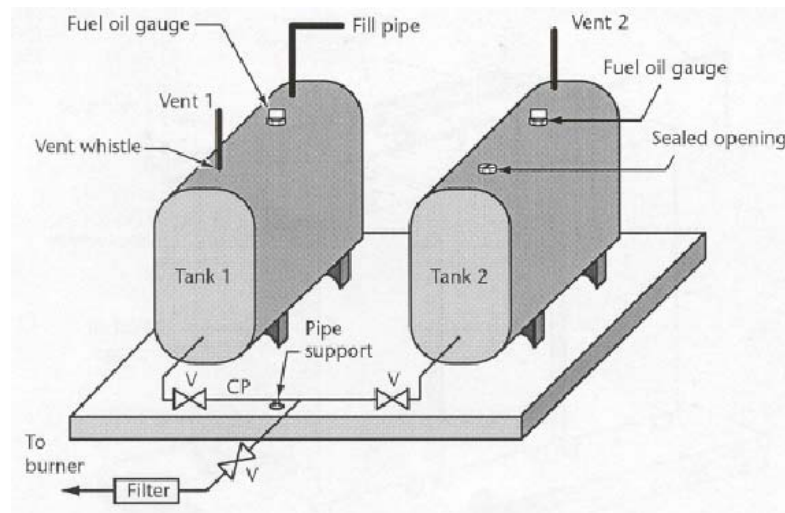

#### Section 14.2

Cross-connect steel tanks with a common manifold vent shall be installed as outlined in Figure 9 and shall include the following specifications:

- (a) fill and vent pipes shall be 50 mm (2 in) pipe;
- (b) the common manifold (M) and manifold vent (MV) shall be 75 mm (3 in) pipe;
- (c) the common manifold shall be at an elevation above the highest liquid level in the tanks;
- (d) shut-off valves (V) shall be installed for each tank;
- (e) the cross connecting pipe (CP) shall be 50 mm (2 in) pipe and substantially supported; and
- (f) both tanks shall be installed on a common slab;

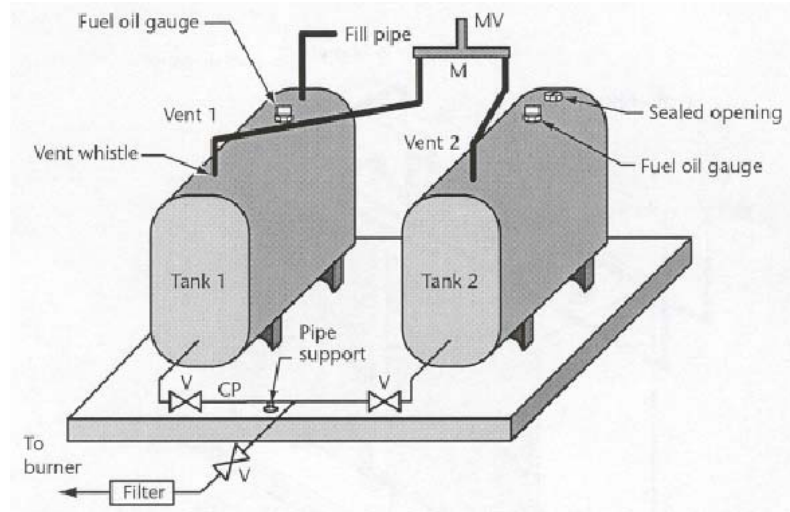
**Figure 9 Cross-Connected Tanks with Manifold Vents**

Section 14.3

Two or more tanks with a total capacity of 2200 litres (1100 gal) or less that are connected with top-mounted manifolds shall be of identical manufacture and individual capacity. The fill and supply manifolds shall be supplied by the tank manufacturer or designed by a professional engineer.

### SCHEDULE C

#### STANDARD FOR THE INSPECTION AND TAGGING OF HOME HEAT TANK SYSTEMS ON PEI WITH A TOTAL CAPACITY OF 2,200 LITRES OR LESS FOR HOME HEAT TANKS INSTALLED PRIOR TO MARCH 2004

##### Section 1.0 General

This standard provides a general overview of the inspection and tagging requirements for home heat tank systems installed prior to March 1, 2004 in the Province of Prince Edward Island. It is not intended to be all inclusive and should be used as a general guide in conjunction with applicable codes and training manuals. Home heat tank systems installed after March 2004 must be inspected and tagged in accordance with the requirements of Schedule B.

This standard is intended to highlight the mandatory inspection requirements for all home heat tanks installed in the Province of Prince Edward Island prior to March 1, 2004. It is intended to be used in conjunction with the applicable versions of CSA B139 Installation Code For Oil-Burning Equipment, CAN/ULC S643 Aboveground Shop Fabricated Steel, Utility Tanks and CAN/ULC S602 Aboveground Steel Tanks for the Storage of Combustible Liquids Intended to be Used as Heating and/or Generator Fuels. The specific version of the codes will depend upon when the tank was originally installed. For example, if the tank was installed in accordance with the CSA B139-00 code, it should also be inspected in accordance with that code.

For the purposes of inspecting home heat tanks on Prince Edward Island, any differences between the B139, CAN/ULC S602, and CAN/ULC S643 codes and these standards, these standards shall be considered paramount.

**Section 2.0 Installation of Outside Tanks**

## Section 2.1

Outside home heat tank systems shall include:

- (a) a prepared support base constructed by removing a minimum of 150 mm (6 in) of top soil and replacing it with an equal amount of tamped sand, crushed gravel, or poured concrete;
- (b) two reinforced patio stones placed level on top of the gravel or tamped sand; *(Note: Reinforced patio stones without the gravel, or 4x4 and larger pressure-treated or creosote timbers are permitted to be used if they are level and in good condition. Individual wooden or cement blocks shall not be used as part of an outside installation);*
- (c) four tank support legs centred on the two re-enforced patio stones or concrete pad ensuring the bottom of the tank is at least 100 mm (4 in) off the support base. Tank legs longer than 300 mm (12 in) must be substantially braced;
- (d) a horizontal vibration loop placed in the product line as close as possible to the shut-off valve;
- (e) a fuel filter connected to the product line and located inside the building, wherever feasible;
- (f) a product line protector;
- (g) a working vent whistle attached to a 37 mm (1 ¼ in) vent pipe;
- (h) a 50 mm (2 in) fill pipe complete with a tight metal cover designed to discourage tampering;
- (i) piping and tubing which is substantially supported and protected against physical damage; and
- (j) a common poured cement pad for two or more cross-connected tanks.

**Section 3.0 Installation of Inside Tanks**

## Section 3.1

Inside home heat tank systems shall include:

- (a) four tank support legs which provide a minimum 100 mm (4 in) space between the tank bottom and the basement floor. *(Note: wooden shims under the tank supports are permitted on an inside tank to provide stability to the tank system and individual cement blocks can be used inside instead of pipe legs provided that no portion of the tank shell is in contact with the cement blocks);*
- (b) a fuel filter connected to the product line;
- (c) a working fuel gauge;
- (d) a working vent whistle attached to the vent pipe;
- (e) a 50 mm (2 in) fill pipe terminating to open air and equipped with a tight metal cover designed to discourage tampering;
- (f) piping and tubing substantially supported and protected against physical damage;
- (g) at least 600 mm (2 ft) horizontal distance from the tank to a petroleum fuel-fired appliance;
- (h) the horizontal distance from the tank to a solid fuel fired appliance is at least 1500 mm (5 ft); and
- (i) there is unimpeded access by a home heat tank to an electrical panel.

**Section 4.0 Fill Pipe Connections**

## Section 4.1

Fill pipes shall be not less than 50 mm (2 in) in diameter.

**Section 4.2**

Fill pipes shall be covered with a weatherproof cap.

**Section 4.3**

Fill pipes shall terminate:

- (a) to open air;
- (b) not less than 600 mm (2 ft) from any building opening;
- (c) not less than 900 mm (3 ft) from an air intake;
- (d) close to the building; and
- (e) below the opening of the vent pipe.

**Section 5.0 Vent Pipe Connections****Section 5.1**

Vent pipes shall be not less than 32 mm (1¼ in) in diameter.

**Section 5.2**

Vent pipes shall be covered with a weatherproof cap.

**Section 5.3**

Vent pipes shall terminate:

- (a) to open air;
- (b) not less than 600 mm (2 ft) from any building opening;
- (c) not less than 900 mm (3 ft) from an air intake;
- (d) close to the building; and
- (e) above the opening of the fill pipe.

**Section 5.4**

When vent pipes from two or more tanks are connected to a common vent, the common vent shall be at least one pipe size larger than the largest vent pipe from the individual tanks.

**Section 5.5**

Vent pipes shall not be cross-connected with fill pipes or with fuel oil return lines from burners.

**Section 6.0 Product Lines****Section 6.1**

When any portion of a product line runs below a foundation wall, under a floor, or under the ground, it shall:

- (a) if installed prior to April 1, 2000, be a continuous length of plain or poly coated copper product line inside a continuous run of tubing which protrudes a minimum of 50 mm (2 in) above the ground or basement floor; or
- (b) if installed after April 1, 2000, be a continuous length of poly coated copper product line inside a continuous run of tubing which protrudes a minimum of 50 mm (2 in) above the ground or basement floor.

**Section 7.0 Piping and Tubing**

## Section 7.1

Fill or vent pipes shall be steel or galvanized construction. Galvanized pipes, except as fill or vent pipes on or supply tanks, shall not be used when exposed to heat or for conveying preheated fuel oil.

## Section 7.2

Flexible metal hose may be used when rigid connections are impracticable, or when required to reduce the effect of jarring or vibration. Such hose shall be of a type certified for the application and shall be installed strictly in accordance with the approval for the appliance.

## Section 7.3

Cast iron or compression fittings shall not be used.

## Section 7.4

A joint in seamless copper, brass, or steel tubing shall be made by means of a flare joint or approved fitting, or shall be brazed with a material having a melting point exceeding 540°C (1000°F).

## Section 7.5

Threaded joints shall be made fuel-oil tight.

**Section 8.0 Shut-off Valves**

A shut-off valve shall be installed in the fuel line as near as practicable to the exit from the supply tank, and at such other locations as may be required to avoid spillage during servicing.

**Section 9.0 Fuel Oil Filters**

A suitable fuel oil filter or strainer assembly shall be provided in the fuel supply line to the oil burner, and shall be located inside the building wherever feasible.

**Section 10.0 Tank Stands**

## Section 10.1

Wooden oil tank stands are permitted for outside installations if constructed using a minimum of 4x4 pressure treated wood for the posts and saddle. These posts must extend high enough on both sides to keep the tank from falling out. The four saddle pieces holding the tank in place shall be a minimum of 4x4 pressure treated wood and bolted together with the four posts. Additional support/cross pieces can be 2x6 pressure treated wood or larger, however, they shall be bolted together using a nut and washer. Except for the leg brackets and pipe legs, no portion of the tank shall rest on the wooden stand.

## Section 10.2

Steel tank stands shall be constructed using a minimum of two inch tubular steel posts or other material as approved by the Department. These posts must extend high enough on both sides to keep the home heat tank from falling out. The four saddle pieces holding the

tank in place shall also be a minimum of two inch square tubular steel. Except for the pipe legs, no portion of the tank shall rest on the steel stand.

**Section 11.0 PEI Aboveground Tank I.D. Tag**

PEI Aboveground Tank I.D tags attached to the outside vent pipe as part of the inspection process shall be attached by means of rivets or other method approved in writing by the Minister.

**Schedule D**  
**Mandatory Replacement Years for Home Heat Tanks**  
**(calculated from the year of manufacture)**

Steel Thickness	Outlet/Connection Type	Mandatory Replacement Year
Non-metallic Tanks	Not applicable	No mandatory replacement year
Double Bottom Metallic Tank	Not Applicable	No mandatory replacement year
Metallic Tank with Nominal steel thickness of 2.0 mm*	Tank end or top burner connection	15 years from year of tank manufacture.
Metallic Tank with Nominal steel thickness of 2.0 mm*	Bottom outlet burner connection	20 years from year of tank manufacture.
Metallic Tank with Nominal steel thickness of 2.3 mm**	Tank end or top burner connection	20 years from year of tank manufacture.
Metallic Tank with Nominal steel thickness of 2.3 mm**	Bottom outlet burner connection	25 years from year of tank manufacture.

\* - The permissible minimal steel thickness of a 2.0 mm (14 gauge) tank is between 1.80 mm and 2.09 mm.

\*\* - The permissible minimum steel thickness of a 2.3 mm (12 gauge) tank is 2.10 mm and above.

**EXPLANATORY NOTES**

**SECTION 1** is the definition section.

**SECTION 2** deals with fees.

**SECTION 3** deals with the application form, the qualifications for, and the issuance of, an installer's licence.

**SECTION 4** deals with the application form, the qualifications for and issuance of an inspector's licence.

**SECTION 5** deals with the revocation of a licence.

**SECTION 6** requires an inspection to be made by a person who installs, alters or moves a home heat tank.

**SECTION 7** deals with compliance with standards, inspection reports and removal of old identification tags.

**SECTION 8** deals with the submission of reports to the Minister.



**SECTION 9** deals with identification tags issued to employers or self-employed licensees and the assignment of identification tags to licensees.

**SECTION 10** requires a licensee to notify the Minister if the licensee finds a non-compliant tank that has an identification tag.

**SECTION 11** prohibits the sale or transfer of identification tags.

**SECTION 12** prohibits the installation, alteration or moving of a home heat tank or system unless it is done by a person holding an installer's licence. An exception is made for the installation by an owner of a product line protector.

**SECTION 13** prohibits the sale of a home heat tank except to a person who holds a licence issued under these regulations and makes an exception where a wholesaler sells to a retailer for resale.

**SECTION 14** prohibits delivering of petroleum to an outside home heat tank that has no product line protector or that has a combustible tank stand. The section also prohibits delivery after September 1, 2007 to a tank that does not have an identification tag.

**SECTION 15** deals with notices respecting a leaking tank.

**SECTION 16** deals with double-walled metallic tanks.

**SECTION 17** deals with access by an environment officer to a home heat tank system.

**SECTION 18** deals with the removal of an identification tag from a non-compliant home heat tank.

**SECTION 19** deals with the replacement of a home heat tank before the expiry date on the identification tag.

**SECTION 20** sets a deadline of September 1, 2007 for inspection and tagging of home heat tank systems.

**SECTION 21** prohibits the transfer of water or sludge between tanks.

**SECTION 22** provides for the forms and Schedules referred to in these regulations to be set out in the Schedule.

**SECTION 23** provides for the commencement of these regulations.

Certified a true copy,

W. Alexander (Sandy) Stewart  
Clerk of the Executive Council

---

## EC2007-243

**LIQUOR CONTROL ACT  
GENERAL REGULATIONS  
AMENDMENT**

(Approved by Her Honour the Lieutenant Governor in Council dated 17 April 2007.)

Pursuant to section 8 of the *Liquor Control Act* R.S.P.E.I. 1988, Cap. L-14, Council made the following regulations:

**1. Subsection 7(2) of the *Liquor Control Act Regulations* (EC704/75) is amended by the deletion of the words “; the fee for a Class II permit shall be twenty-five dollars and in addition, at the time of the purchase of liquor, the permit holder shall pay the amount equal to ten per cent of the purchase price on all spirits and wine” and the substitution of the words “and the fee for a Class II permit shall be twenty-five dollars”.**

**2. Section 20 of the regulations is amended by the deletion of the words “and in addition, payable at the time of purchase, an amount equal to ten per cent on the purchase price of all spirits and wine”.**

**3. Section 29 of the regulations is amended by the deletion of the words “in addition, payable at the time of purchase, an amount to equal ten per cent of the purchase price of all spirits and wine”.**

**4. Section 40 of the regulations is amended by the deletion of the words “two hundred dollars for a membership of over one hundred and fifty; and in addition payable at the time of purchase, an amount equal to ten per cent of the purchase price of all spirits and wine” and the substitution of the words “and two hundred dollars for a membership of over one hundred and fifty”.**

**5. Section 50 of the regulations is amended by the deletion of the words “and in addition, payable at the time of purchase an amount equal to ten per cent of the purchase price of all spirits and wine”.**

**6. (1) Subsection 50.1(1) of the regulations is amended by the deletion of the words “and the fee of \$200” and the substitution of the words “and the prescribed fee”.**

**(2) Subsection 50.1(4) of the regulations is revoked and the following is substituted:**

Annual fees

(4) The holder of a special premises license shall pay an annual fee of \$200.

**7. Subsection 50.2(5) of the regulations is revoked and the following substituted:**

(5) The holder of a caterer's license shall pay an annual fee of \$200. Fees

**8. (1) Subsection 50.3(2) of the regulations is amended by the deletion of the words "a fee of \$200" and the substitution of the words "the prescribed fee".**

**(2) Section 50.3 of the regulations is amended by the addition of the following after subsection (3):**

(3.1) The holder of a winery license shall pay an annual fee of \$200. Fees

**9. (1) Subsection 50.4(1) of the regulations is amended by the deletion of the words "the fee of \$100, or \$50 for six months" and the substitution of the words "the prescribed fee".**

**(2) Subsection 50.4(4) of the regulations is revoked and the following substituted:**

(4) A tourist home licensee shall pay an annual fee of \$100, or \$50 for six months. Fees

**10. Form 7 of the regulations is amended by the deletion of the words "The 10 percent surcharge on spirits and wines is paid at the liquor store where liquor is purchased."**

**11. These regulations come into force on April 30, 2007.**

#### EXPLANATORY NOTES

**SECTIONS 1 to 10** amend the regulations to drop the current 10 percent regulatory fee on the purchase of liquor by various types of license holders.

**SECTION 11** provides for the commencement of these regulations.

Certified a true copy,  
W. Alexander (Sandy) Stewart  
Clerk of the Executive Council

---

**PART II**  
**REGULATIONS INDEX**

Chapter Number	Title	Original Order Reference	Amendment	Authorizing Order and Date	Page
E-9	<b>Environmental Protection Act</b> Excavation Pits Regulations	EC753/90	s.1(a.1) [added] s.1(g) [added] s.3(1) [R&S] s.3(3)(i) s.3(3)(j) s.3(3)(k) [R&S] s.3(6) [R&S] s.3(7) [rev] s.4.1 [added] s.4(1)(d) [R&S] s.4(1)(d.1) [added] s.4(1)(j) [rev] s.4(3) [R&S] s.9 [rev] [eff] Apr. 28/07	EC2007-239 (17.04.07)	99-101
	Petroleum Storage Tanks Regulations		[new] [eff] Apr. 28/07	2007-240 (17.04.07)	102-124
		EC322/01	[rev] [eff] Apr. 28/07	2007-240 (17.04.07)	117
	Home Heat Tanks Regulations		[new] [eff] Apr. 28/07	2007-241 (17.04.07)	124-151
L-14	<b>Liquor Control Act</b> General Regulations	EC704/75	s.7(2) s.20 s.29 s.40 s.50 s.50.1(1) s.50.1(4) [R&S] s.50.2(5) [R&S] s.50.3(2) s.50.3(3.1) [added] s.50.4(1) s.50.4(4) [R&S] Form 7 [eff] Apr. 30/07	EC2007-243 (17.04.07)	152-153