

Guide to Solid Phase Extraction

	Page
Introduction	1
Phase Types	2
Reversed phase packings	
Normal phase packings	
Ion exchange packings	
Adsorption packings	
SPE Theory	3
How compounds are retained by the sorbent	
Reversed phase SPE	
Normal phase SPE	
Ion exchange SPE	
Secondary interactions	
The role of pH in SPE	
How to Use SPE	6
Selecting the proper extraction scheme	
The five-step SPE method development process	
Sample pretreatment options	
- Liquid samples	
- Solid samples	
SPE hardware and accessories for processing samples	

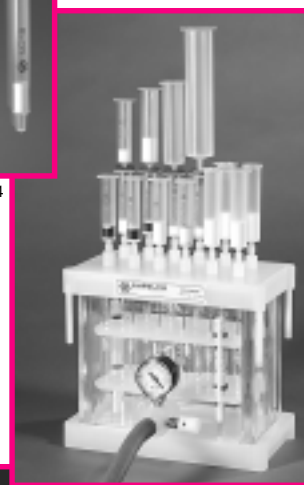

9950124



9960029



9970312



9940256

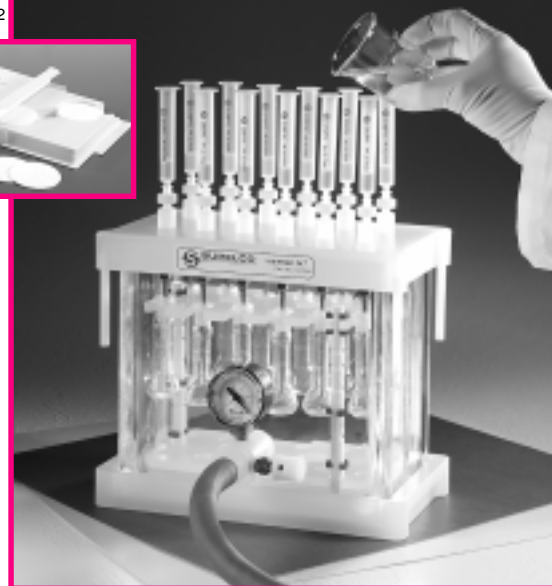

9960028

Introduction

Solid phase extraction (SPE) is an increasingly useful sample preparation technique. With SPE, many of the problems associated with liquid/liquid extraction can be prevented, such as incomplete phase separations, less-than-quantitative recoveries, use of expensive, breakable specialty glassware, and disposal of large quantities of organic solvents. SPE is more efficient than liquid/liquid extraction, yields quantitative extractions that are easy to perform, is rapid, and can be automated. Solvent use and lab time are reduced.

SPE is used most often to prepare liquid samples and extract semivolatile or nonvolatile analytes, but also can be used with solids that are pre-extracted into solvents. SPE products are excellent for sample extraction, concentration, and cleanup. They are available in a wide variety of chemistries, adsorbents, and sizes. Selecting the most suitable product for each application and sample is important.

SPE Phase Types

Reversed Phase	Silica-Based Packing – 40µm particles, 60Å pores (unless otherwise noted).		
	LC-18	octadecyl bonded, endcapped silica	For reversed phase extraction of nonpolar to moderately polar compounds, such as antibiotics, barbiturates, benzodiazepines, caffeine, drugs, dyes, essential oils, fat soluble vitamins, fungicides, herbicides, pesticides, hydrocarbons, parabens, phenols, phthalate esters, steroids, surfactants, theophylline, and water soluble vitamins.
	ENVI™-18	octadecyl bonded, endcapped silica	Higher phase coverage and carbon content than LC-18, greater resistance to extreme pH conditions, and slightly higher capacity for nonpolar compounds. For reversed phase extraction of nonpolar to moderately polar compounds, such as antibiotics, caffeine, drugs, dyes, essential oils, fat soluble vitamins, fungicides, herbicides, pesticides, PNAs, hydrocarbons, parabens, phenols, phthalate esters, steroids, surfactants, water soluble vitamins. Also available in disk format.
	LC-8	octyl bonded, endcapped silica	For reversed phase extraction of nonpolar to moderately polar compounds, such as antibiotics, barbiturates, benzodiazepines, caffeine, drugs, dyes, essential oils, fat soluble vitamins, fungicides, herbicides, pesticides, hydrocarbons, parabens, phenols, phthalate esters, steroids, surfactants, theophylline, and water soluble vitamins. Also available in disk format.
	ENVI-8	octyl bonded, endcapped silica	Higher phase coverage and carbon content than LC-8, greater resistance to extreme pH conditions, and slightly higher capacity for nonpolar compounds. For reversed phase extraction of barbiturates, benzodiazepines, caffeine, drugs, dyes, essential oils, fat soluble vitamins, fungicides, herbicides, pesticides, PNAs, hydrocarbons, parabens, phenols, phthalate esters, steroids, surfactants, theophylline, water soluble vitamins.
	LC-4	butyldimethyl bonded, endcapped silica (500Å pores)	Less hydrophobic than LC-8 or LC-18. For extraction of peptides and proteins.
	LC-Ph	phenyl bonded silica	Slightly less retention than LC-18 or LC-8 material. For reversed phase extraction of nonpolar to moderately polar compounds, especially aromatic compounds.
Normal Phase	Hisep™	hydrophobic surface enclaved by a hydrophilic network	For exclusion of proteins in biological samples; retains small molecules such as drugs under reversed phase conditions.
	LC-CN	cyanopropyl bonded, endcapped silica	For reversed phase extraction of moderately polar compounds, normal phase extraction of polar compounds, such as aflatoxins, antibiotics, dyes, herbicides, pesticides, phenols, steroids. Weak cation exchange for carbohydrates and cationic compounds.
	LC-Diol	diol bonded silica	For normal phase extraction of polar compounds.
Ion Exchange	LC-NH ₂	aminopropyl bonded silica	For normal phase extraction of polar compounds, weak anion exchange for carbohydrates, weak anions, and organic acids.
	LC-SAX	quaternary amine bonded silica with Cl ⁻ counterion	For strong anion exchange for anions, organic acids, nucleic acids, nucleotides, and surfactants. Capacity: 0.2meq/g.
	LC-SCX	sulfonic acid bonded silica with Na ⁺ counterion	For strong cation exchange for cations, antibiotics, drugs, organic bases, amino acids, catecholamines, herbicides, nucleic acid bases, nucleosides, and surfactants. Capacity: 0.2meq/g.
Adsorption	LC-WCX	carboxylic acid bonded silica with Na ⁻ counterion	For weak cation exchange of cations, amines, antibiotics, drugs, amino acids, catecholamines, nucleic acid bases, nucleosides, and surfactants.
	LC-Si	silica gel with no bonded phase	For extraction of polar compounds, such as alcohols, aldehydes, amines, drugs, dyes, herbicides, pesticides, ketones, nitro compounds, organic acids, phenols, and steroids.
	Alumina-Based Packing – Crystalline, chromatographic grade alumina, irregular particles, 60/325 mesh.		
	LC-Alumina-A	acidic pH ~5	For anion exchange and adsorption extraction of polar compounds, such as vitamins.
	LC-Alumina-B	basic pH ~8.5	For adsorption extraction of polar compounds, and cation exchange.
	LC-Alumina-N	neutral pH ~6.5	For adsorption extraction of polar compounds. With pH adjustment, cation or anion exchange. For extraction of vitamins, antibiotics, essential oils, enzymes, glycosides, and hormones.
	Florisil®-Based Packing – Magnesium silicate, 100/120 mesh particles.		
	LC-Florisil		For adsorption extraction of polar compounds, such as alcohols, aldehydes, amines, drugs, dyes, herbicides, pesticides, PCBs, ketones, nitro compounds, organic acids, phenols, and steroids.
	ENVI-Florisil [▲]		For adsorption extraction of polar compounds, such as alcohols, aldehydes, amines, drugs, dyes, herbicides, pesticides, PCBs, ketones, nitro compounds, organic acids, phenols, and steroids.
	Graphitized Carbon-Based Packing – Nonbonded carbon phase.		
ENVI-Carb	nonporous, surface area 100m ² /g, 120/400 mesh	For adsorption extraction of polar and nonpolar compounds.	
ENVI-Carb C	nonporous, surface area 10m ² /g, 80/100 mesh	For adsorption extraction of polar and nonpolar compounds.	
Resin-Based Packing – 80-160µm spherical particles.			
ENVI-Chrom P ^{▲▲}		For extraction of polar aromatic compounds such as phenols from aqueous samples. Also for adsorption extraction of nonpolar to midpolar aromatic compounds.	

▲ SPE tubes that are packed with this material contain stainless steel or Teflon® frits, required by US Environmental Protection Agency Contract Laboratory Program (CLP) pesticide methods.

▲▲ Highly crosslinked, neutral, specially cleaned styrene-divinylbenzene resin. Very high surface area, mean pore size 110-175Å.

SPE Theory

How Compounds Are Retained by the Sorbent

Reversed Phase

(polar liquid phase, nonpolar modified solid phase)

Hydrophobic interactions

- nonpolar-nonpolar interactions
- van der Waals or dispersion forces

Normal Phase

(nonpolar liquid phase, polar modified solid phase)

Hydrophilic interactions

- polar-polar interactions
- hydrogen bonding
- pi-pi interactions
- dipole-dipole interactions
- dipole-induced dipole interactions

Ion Exchange

Electrostatic attraction of charged group on compound to a charged group on the sorbent's surface

Adsorption

(interactions of compounds with unmodified materials)

Hydrophobic and hydrophilic interactions may apply
Depends on which solid phase is used

Reversed Phase SPE

Reversed phase separations involve a polar (usually aqueous; see Table A on page 8) or moderately polar sample matrix (mobile phase) and a nonpolar stationary phase. The analyte of interest is typically mid- to nonpolar. Several SPE materials, such as the alkyl- or aryl-bonded silicas (**LC-18**, **ENVI-18**, **LC-8**, **ENVI-8**, **LC-4**, and **LC-Ph**) are in the reversed phase category. Here, the hydrophilic silanol groups at the surface of the raw silica packing (typically 60 Å pore size, 40 μm particle size) have been chemically modified with hydrophobic alkyl or aryl functional groups by reaction with the corresponding silanes.

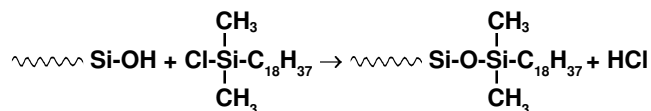

Retention of organic analytes from polar solutions (e.g. water) onto these SPE materials is due primarily to the attractive forces between the carbon-hydrogen bonds in the analyte and the functional groups on the silica surface. These nonpolar-nonpolar attractive forces are commonly called van der Waals forces, or dispersion forces. To elute an adsorbed compound from a reversed phase SPE tube or disk, use a nonpolar solvent to disrupt the forces that bind the compound to the packing. **LC-18** and **LC-8** are standard, monomerically bonded silicas. Polymerically bonded materials, such as **ENVI-18** and **ENVI-8**, result in a more complete coverage of the silica surface and higher carbon loading. Polymeric bonding is more resistant to pH extremes, and thus is more suitable for environmental applications for trapping organic compounds from acidified aqueous samples. All silica-based bonded phases have some percentage of residual unreacted silanols that act as secondary interaction sites. These secondary interactions may be useful in the extraction or retention of highly polar analytes or contaminants, but may also irreversibly bind analytes of interest (see *Secondary Interactions* on page 5).

The following materials also are used under reversed phase conditions: **ENVI-Carb** (carbon-based), **ENVI-Chrom P** (polymer-based), and **Hisep** (polymer-coated and bonded silica).

Carbonaceous adsorption media, such as the **ENVI-Carb** materials, consist of graphitic, nonporous carbon that has a high attraction for organic polar and nonpolar compounds from both polar and nonpolar matrices. The carbon surface is comprised of atoms in hexagonal ring structures, interconnected and layered in graphitic sheets. The hexagonal ring structure demonstrates a strong selectivity for planar aromatic or hexagonal ring-shaped molecules and hydrocarbon chains with potential for multiple surface contact points. Retention of analytes is based primarily on the analyte's structure (size and shape), rather than on interactions of functional groups on the analyte with the sorbent surface. Elution is performed with mid- to nonpolar solvents. The unique structure and selectivity of **ENVI-Carb** materials, compared to bonded alkyl-silicas, makes them an excellent alternative when the bonded silicas will not work for an application.

Polymeric adsorption media such as the **ENVI-Chrom P** material also is used in reversed phase fashion. **ENVI-Chrom P** is a styrene/divinylbenzene material that is used for retaining hydrophobic compounds which contain some hydrophilic functionality, especially aromatics. Phenols are sometimes difficult to retain on C18-modified silica under reversed phase conditions, mainly due to their greater solubility in water than in organic matrices. The **ENVI-Chrom P** material has been shown to retain phenols well under reversed phase conditions. Elution steps can be done with mid- to nonpolar solvents, because the polymeric packing is stable in almost all matrices.

Hisep is a hydrophobic (C18-like) bonded silica that is coated with a hydrophilic polymer and is typically used under reversed phase conditions. The porous polymer coating prevents the adsorption of large, unwanted molecules onto the silica surface. The pores in the polymer allow small, hydrophobic organic compounds of interest (such as drugs) to reach the bonded silica surface, while large interfering compounds (such as proteins) are shielded from the bonded silica by the polymer and are flushed through the SPE tube. SPE procedures on **Hisep** material are similar to those on **LC-18**.

Normal Phase SPE

Normal phase SPE procedures typically involve a polar analyte, a mid- to nonpolar matrix (e.g. acetone, chlorinated solvents, and hexane), and a polar stationary phase. Polar-functionalized bonded silicas (e.g. **LC-CN**, **LC-NH₂**, and **LC-Diol**), and polar adsorption media (**LC-Si**, **LC-Florisil**, **ENVI-Florisil**, and **LC-Alumina**) typically are used under normal phase conditions. Retention of an analyte under normal phase conditions is primarily due to interactions between polar functional groups of the analyte and polar groups on the sorbent surface. These include hydrogen bonding, pi-pi interactions, dipole-dipole interactions, and dipole-induced dipole interactions, among others. A compound adsorbed by these mechanisms is eluted by passing a solvent that disrupts the binding mechanism — usually a solvent that is more polar than the sample's original matrix.

The bonded silicas — **LC-CN**, **LC-NH₂**, and **LC-Diol** — have short alkyl chains with polar functional groups bonded to the surface. These silicas, because of their polar functional groups, are much more hydrophilic relative to the bonded reversed phase silicas. As with typical normal phase silicas, these packings can be used to adsorb polar compounds from nonpolar matrices. Such SPE tubes have been used to adsorb and selectively elute compounds of very similar structure (e.g. isomers), or complex mixtures or classes of compounds such as drugs and lipids. These materials

also can be used under reversed phase conditions (with aqueous samples), to exploit the hydrophobic properties of the small alkyl chains in the bonded functional groups.

The **LC-Si** material is underivatized silica commonly used as the backbone of all of the bonded phases. This silica is extremely hydrophilic, and must be kept dry. All samples used with this material must be relatively water-free. The functional groups that are involved in the adsorption of compounds from nonpolar matrices are the free hydroxyl groups on the surface of the silica particles. LC-Si may be used to adsorb polar compounds from nonpolar matrices with subsequent elution of the compounds in an organic solvent that is more polar than the original sample matrix. In most cases, LC-Si is used as an adsorption media, where an organic extract is applied to the silica bed, the analyte of interest passes through unretained, and the unwanted compounds adsorb onto the silica and are discarded. This procedure is usually called *sample cleanup*.

LC-Florisil and **ENVI-Florisil** SPE tubes are packed with a magnesium silicate that is used typically for sample cleanup of organic extracts. This highly polar material strongly adsorbs polar compounds from nonpolar matrices. The ENVI-Florisil SPE tubes are made with either Teflon® or stainless steel frits, a configuration necessary for environmental procedures specified in US EPA methods. ENVI-Florisil is specifically tested for low backgrounds via GC analysis.

LC-Alumina SPE tubes are also used in adsorption/sample cleanup-type procedures. The aluminum oxide materials can either be of acidic (Alumina-A, pH ~5), basic (Alumina-B, pH ~8.5), or neutral (Alumina-N, pH ~6.5) pH, and are classified as having Brockmann Activities of I. The activity level of the alumina may be altered from grade I through grade IV with the controlled addition of water, prior to or after packing this material into tubes.

Ion Exchange SPE

Ion exchange SPE can be used for compounds that are charged when in a solution (usually aqueous, but sometimes organic). Anionic (negatively charged) compounds can be isolated on **LC-SAX** or **LC-NH₂** bonded silica cartridges. Cationic (positively charged) compounds are isolated by using **LC-SCX** or **LC-WCX** bonded silica cartridges. The primary retention mechanism of the compound is based mainly on the electrostatic attraction of the charged functional group on the compound to the charged group that is bonded to the silica surface. In order for a compound to retain by ion exchange from an aqueous solution, the pH of the sample matrix must be one at which both the compound of interest and the functional group on the bonded silica are charged. Also, there should be few, if any, other species of the same charge as the compound in the matrix that may interfere with the adsorption of the compound of interest. A solution having a pH that neutralizes either the compound's functional group or the functional group on the sorbent surface is used to elute the compound of interest. When one of these functional groups is neutralized, the electrostatic force that binds the two together is disrupted and the compound is eluted. Alternatively, a solution that has a high ionic strength, or that contains an ionic species that displaces the adsorbed compound, is used to elute the compound.

Anion Exchange SPE

The **LC-SAX** material is comprised of an aliphatic quaternary amine group that is bonded to the silica surface. A quaternary amine is a strong base and exists as a positively-charged cation that exchanges or attracts anionic species in the contacting solution — thus the term strong anion exchanger (SAX). The pKa of a quaternary amine is very high (greater than 14), which makes

the bonded functional group charged at all pHs when in an aqueous solution. As a result, LC-SAX is used to isolate strong anionic (very low pKa, <1) or weak anionic (moderately low pKa, >2) compounds, as long as the pH of the sample is one at which the compound of interest is charged. For an anionic (acidic) compound of interest, the pH of the matrix must be 2 pH units above its pKa for it to be charged. In most cases, the compounds of interest are strong or weak acids.

Because it binds so strongly, LC-SAX is used to extract strong anions only when recovery or elution of the strong anion is not desired (the compound is isolated and discarded). Weak anions can be isolated and eluted from LC-SAX because they can be either displaced by an alternative anion or eluted with an acidic solution at a pH that neutralizes the weak anion (2 pH units below its pKa). If recovery of a strongly anionic species is desired, use LC-NH₂.

The **LC-NH₂** SPE material that is used for normal phase separations is also considered to be a weak anion exchanger (WAX) when used with aqueous solutions. The LC-NH₂ material has an aliphatic aminopropyl group bonded to the silica surface. The pKa of this primary amine functional group is around 9.8. For it to be used as an anion exchanger, the sample must be applied at a pH at least 2 units below 9.8. The pH must also be at a value where the anionic compound of interest is also charged (2 pH units above its own pKa). LC-NH₂ is used to isolate and recover both strong and weak anions because the amine functional group on the silica surface can be neutralized (2 pH units above its pKa) in order to elute the strong or weak anion. Weak anions also can be eluted from LC-NH₂ with a solution that neutralizes the adsorbed anion (2 pH units below its pKa), or by adding a different anion that displaces the analyte.

Cation Exchange

The **LC-SCX** material contains silica with aliphatic sulfonic acid groups that are bonded to the surface. The sulfonic acid group is strongly acidic (pKa <1), and attracts or exchanges cationic species in a contacting solution — thus the term strong cation exchanger (SCX). The bonded functional group is charged over the whole pH range, and therefore can be used to isolate strong cationic (very high pKa, >14) or weak cationic (moderately high pKa, <12) compounds, as long as the pH of the solution is one at which the compound of interest is charged. For a cationic (basic) compound of interest, the pH of the matrix must be 2 pH units below its pKa for it to be charged. In most cases, the compounds of interest are strong or weak bases.

LC-SCX SPE tubes should be used to isolate strong cations only when their recovery or elution is not desired. Weak cations can be isolated and eluted from LC-SCX; elution is done with a solution at 2 pH units above the cation's pKa (neutralizing the analyte), or by adding a different cation that displaces the analyte. If recovery of a strongly cationic species is desired, use LC-WCX.

The **LC-WCX** SPE material contains an aliphatic carboxylic acid group that is bonded to the silica surface. The carboxylic acid group is a weak anion, and is thus considered a weak cation exchanger (WCX). The carboxylic acid functional group in LC-WCX has a pKa of about 4.8, will be negatively charged in solutions of at least 2 pH units above this value, and will isolate cations if the pH is one at which they are both charged. LC-WCX can be used to isolate and recover both strong and weak cations because the carboxylic acid functional group on the silica surface can be neutralized (2 pH units below its pKa) in order to elute the strong or weak cation. Weak cations also can be eluted from LC-WCX with a solution that neutralizes the adsorbed cation (2 pH units above its pKa), or by adding a different cation that displaces the analyte.

In many cases, the analyte in ion exchange SPE is eluted in an aqueous solution. If you must use an acidic or basic solution to elute an analyte from an SPE tube, but the extracted sample must be analyzed in an organic solvent that is not miscible with water, try to elute the compound with acidic methanol (98% methanol/2% concentrated HCl) or basic methanol (98% methanol/2% NH₄OH). The methanol can be evaporated quickly, and the sample may be reconstituted in a different solvent. If you need a stronger (more nonpolar) solvent to elute the analyte from the SPE tube, add methylene chloride, hexane, or ethyl acetate to the acidic or basic methanol.

Secondary Interactions

The primary retention mechanisms for compounds on the SPE materials are described above. For the bonded silicas, it is possible that secondary interactions will occur.

For *reversed phase bonded silicas*, the primary retention mechanism involves nonpolar interactions. However, because of the silica particle backbone, some polar secondary interactions with residual silanols — such as those described for normal phase SPE — could occur. If a nonpolar solvent does not efficiently elute a compound from a reversed phase SPE packing, the addition of a more polar solvent (e.g. methanol) may be necessary to disrupt any polar interactions that retain the compound. In these cases, methanol can hydrogen-bond with the hydroxyl groups on the silica surface, thus breaking up any hydrogen bonding that the analyte may be incurring.

The silanol group at the surface of the silica, Si-OH, can also be acidic, and may exist as an Si-O⁻ group above pH 4. As a result, the silica backbone may also have cation exchange secondary interactions, attracting cationic or basic analytes of interest. In this case, a pH adjustment of the elution solvent may be necessary to disrupt these interactions for elution (acidic to neutralize the silanol group, or basic to neutralize the basic analyte). This can be done by using acidic methanol (98% MeOH:2% concentrated HCl) or basic methanol (98% MeOH:2% concentrated NH₄OH), or by mixtures of these with a more nonpolar, methanol-miscible solvent.

Normal phase bonded silicas will exhibit primary polar retention mechanisms via the bonded functional group, but also can have some secondary nonpolar interactions of the analyte with the small alkyl chain that supports the functional group. In this case, a more nonpolar solvent, or a mix of polar and nonpolar solvents, may be needed for elution. As with the reversed phase silicas, secondary polar or cation exchange interactions of the adsorbed compound may occur with the silica backbone.

Ion exchange bonded silicas can provide secondary nonpolar interactions of analytes with the nonpolar portions of their functional groups, as well as polar and cation exchange interactions of the analyte with the silica backbone. A delicate balance of pH, ionic strength, and organic content may be necessary for elution of the analyte of interest from these packings.

The Role of pH in SPE

Solutions used in SPE procedures have a very broad pH range. Silica-based packings, such as those used in HPLC columns, usually have a stable pH range of 2 to 7.5. At pH levels above and below this range, the bonded phase can be hydrolyzed and cleaved off the silica surface, or the silica itself can dissolve. In SPE, however, the solutions usually are in contact with the sorbent for short periods of time. The fact that SPE cartridges are disposable, and are meant to be used only once, allows one to use any pH to optimize retention or elution of analytes. If stability of the SPE cartridge at an extreme pH is crucial, polymeric or carbon-

based SPE materials such as ENVI-Chrom P or ENVI-Carb may be used. These materials are stable over the pH range of 1-14.

For **reversed phase** SPE procedures on bonded silicas, if trapping the analyte in the tube is desired, the pH of the conditioning solution and sample (if mostly or entirely aqueous) should be adjusted for optimum analyte retention. If the compound of interest is acidic or basic you should, in most cases, use a pH at which the compound is not charged. Retention of neutral compounds (no acidic or basic functional groups) usually is not affected by pH. Conversely, you can use a pH at which the unwanted compounds in the sample are retained on the SPE packing, but the analyte of interest passes through unretained. Secondary hydrophilic and cation exchange interactions of the analyte can be used for retention at a proper pH. (For more detail, see *Secondary Interactions*).

For **adsorption media** (e.g. ENVI-Carb and ENVI-Chrom P) that are used under reversed phase conditions, a pH should be chosen to maximize retention of analytes on the sorbent as with reversed phase bonded silicas. Elution is usually done with an organic solvent, so pH is usually not a factor at this point. Surprisingly, phenols retain better on ENVI-Chrom P when applied in solutions at a neutral pH, where phenols can be charged, than at an acidic pH levels where they are neutral. This shows that adsorption media may have different selectivities than the bonded silicas for certain compounds, and that a range of pH levels of the sample and conditioning solutions should be investigated when using these materials.

In **normal phase** SPE procedures on bonded silicas or adsorption media, pH is usually not an issue, because the solvents used in these processes are typically nonpolar organic solvents, rather than water.

Retention in **ion exchange** SPE procedures depends heavily on the pH of the sample and the conditioning solutions. For retention of the analyte, the pH of the sample must be one at which the analyte and the functional groups on the silica surface are charged oppositely. For further details, see *Ion Exchange* on page 4.

Typical SPE Tube and Disk

SPE Tube

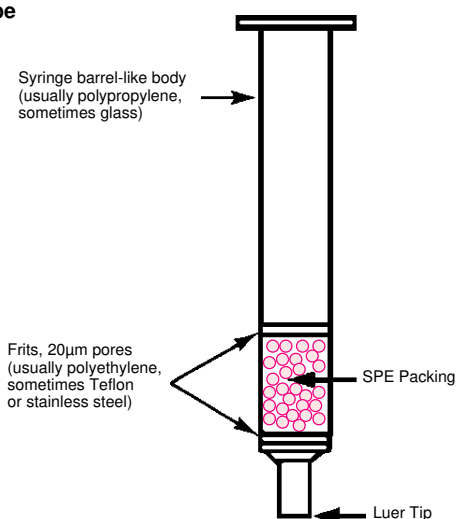

SPE ENVI-Disk

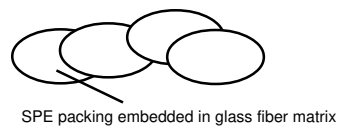

713-0479, G000071

How to Use SPE

Solid phase extraction is used to separate compounds of interest from impurities in three ways. Choose the most appropriate scheme for your sample:

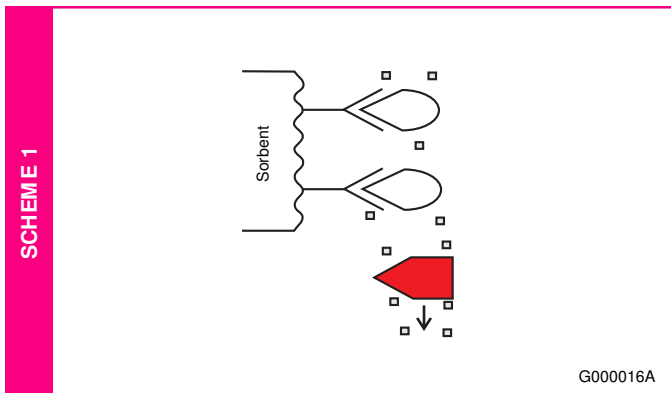
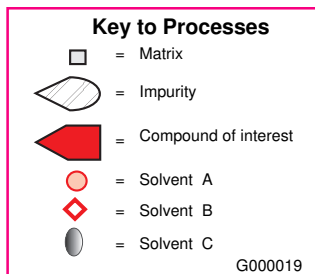

Selective Extraction. Select an SPE sorbent that will bind selected components of the sample — either the compounds of interest or the sample impurities. The selected components are retained when the sample passes through the SPE tube or disk (the effluent will contain the sample minus the adsorbed components). Then, either collect the adsorbed compounds of interest through elution, or discard the tube containing the extracted impurities.

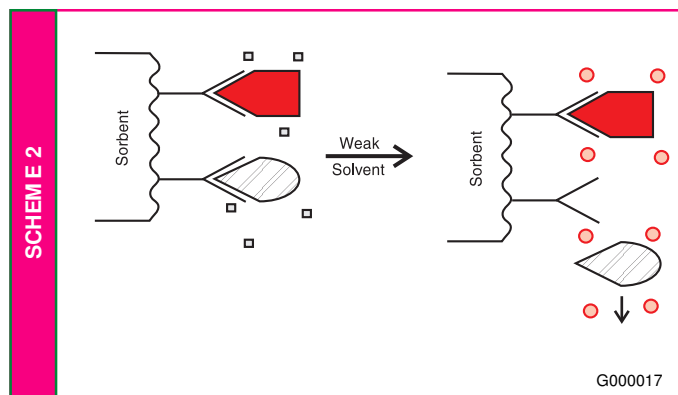

Selective Washing. The compounds of interest and the impurities are retained on the SPE packing when the sample passes through; the impurities are rinsed through with wash solutions that are strong enough to remove them, but weak enough to leave the compounds of interest behind.

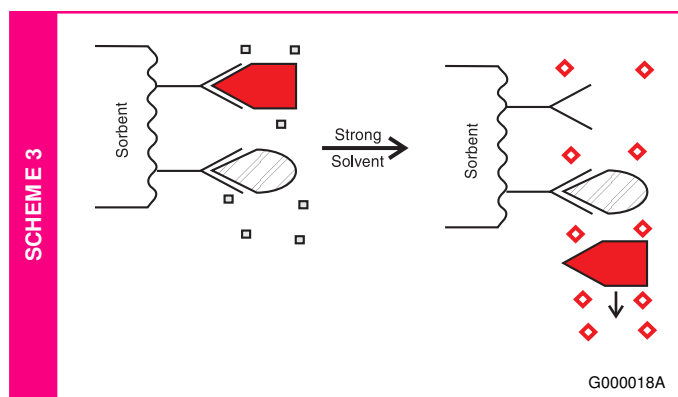

Selective Elution. The adsorbed compounds of interest are eluted in a solvent that leaves the strongly retained impurities behind.

SPE Is a Five-Step Process

The SPE process provides samples that are in solution, free of interfering matrix components, and concentrated enough for detection. This is done in five steps (summarized here and described on the next two pages).

- For reversed phase, normal phase, and ion exchange SPE procedures, all five steps typically are needed.
- For some sample cleanup procedures, only the first three steps may apply. Steps 1 and 2 are the same as shown. However, in step 3, the analyte is collected in the effluent as the sample passes through the tube; interfering impurities remain on the sorbent.

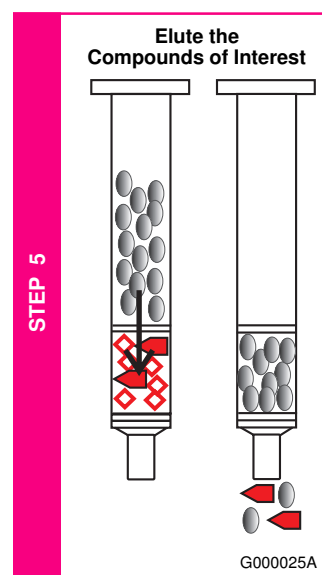
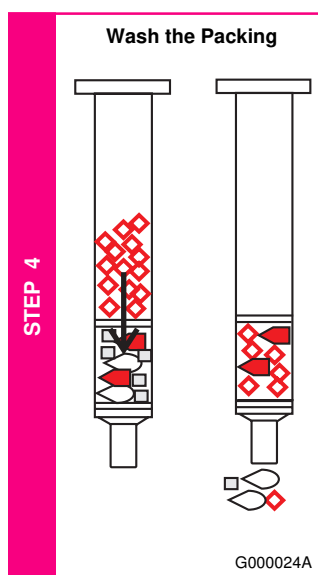
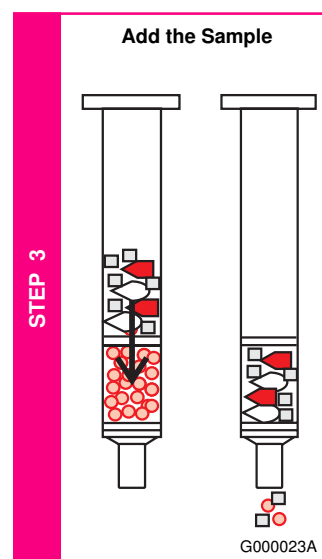
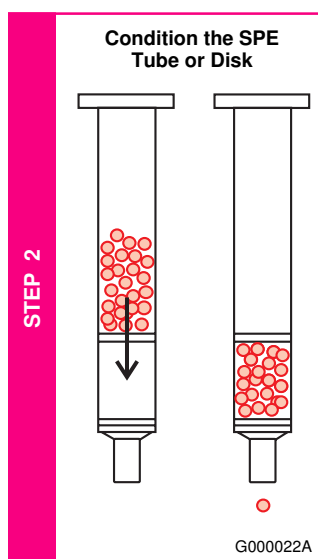
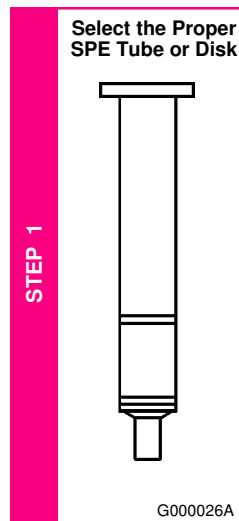

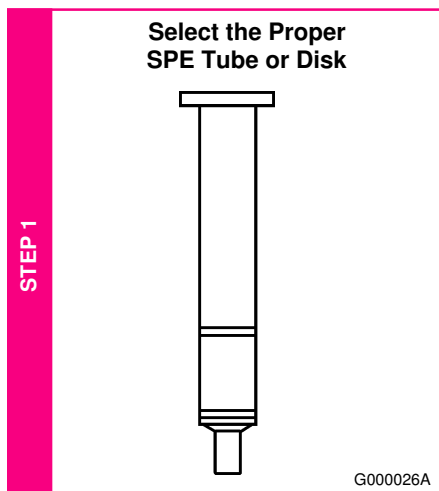

Note: An SPE disk is recommended for large volume samples, samples containing high amounts of particulates, or when a high flow rate is required during sampling.

Selecting an SPE Tube or Disk: Size

Selecting SPE Tube Size

If Your Sample Is . . .	Use Tube Size . . .
< 1mL	1mL
1mL to 250mL and the extraction speed is not critical	3mL
1mL to 250mL and a fast extraction procedure is required	6mL
10mL to 250mL and higher sample capacity is needed	12, 20, or 60mL
< 1 liter and extraction speed is not critical	12, 20, or 60mL

Selecting SPE Disk Size

If Your Sample Is . . .	Use Disk Size . . .
100mL to 1 liter	47mm
>1 liter and higher sample capacity is needed	90mm

Selecting an SPE Tube: Bed Weight

Reversed Phase, Normal Phase, and Adsorption-Type Procedures:

The mass of the compounds to be extracted should not be more than 5% of the mass of the packing in the tube.

In other words, if you are using a 100mg/1mL SPE tube, do not load more than 5mg of analytes.

Ion Exchange Procedures:

You must consider ion exchange capacity.

- LC-SAX and LC-SCX tubes have ~0.2meq/gram of sorbent capacity (1 meq = 1mmole of [+1] or [-1] charged species).
- LC-NH₂ and LC-WCX tubes: ion exchange capacities should be determined for your own application.

Selecting an SPE Tube: Sorbent Type

(Note: Refer to schematic on page 12.)

Is your sample matrix aqueous or organic?

If aqueous:

Is your analyte of interest more soluble in **water** or in **organic solvents** (e.g., hexane or dichloromethane)?

If more soluble in water, is your analyte charged or neutral?

Charged:

If weakly anionic (-) and acidic, use an LC-SAX or LC-NH₂ tube.

If strongly anionic (-) and acidic:

- and you want to recover the extracted analyte, use an LC-NH₂ tube.
- and you do not want to recover the extracted analyte, use an LC-SAX tube.

If weakly cationic (+) and basic, use an LC-SCX or LC-WCX tube.

If strongly cationic (+) and basic:

- and you want to recover the extracted analyte, use an LC-WCX tube.
- and you do not want to recover the extracted analyte, use an LC-SCX tube.

Neutral:

If analytes are difficult to extract using reversed phase packings (e.g. alcohols, sugars, glycols), try an ENVI-Carb or ENVI-Chrom P tube, or try to remove interferences by reversed phase extraction or by using an LC-SAX or LC-SCX tube.

If more soluble in organics, is your analyte charged or neutral?

Charged:

Try reversed phase or ion exchange extraction.

Neutral:

Try reversed phase extraction.

If organic:

Try any of the following.

- Concentrate analyte by evaporation.
- Evaporate to dryness and reconstitute with another solvent.
- Use SPE.

Is the organic solvent **polar** and water-miscible (e.g. methanol or acetonitrile) or **mid- to nonpolar** and not water-miscible (e.g. dichloromethane or hexane)? Refer to **Table A**.

If polar:

Dilute with water to <10% organic and follow the matrix scheme for aqueous analytes.

If mid- to nonpolar:

Use normal phase, or evaporate to dryness, reconstitute with water or a water-miscible solvent, then dilute with water as above and use the matrix scheme for aqueous analytes.

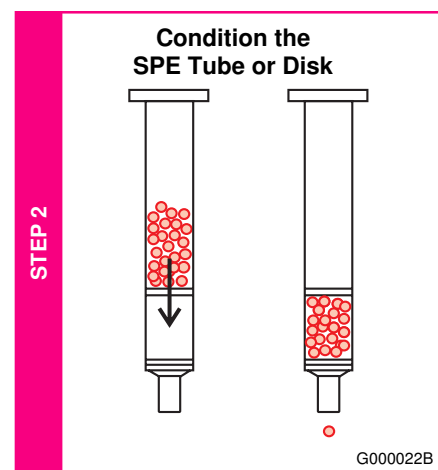

To condition the SPE tube packing, rinse it with up to one tube-full of solvent before extracting the sample. For disks, use a volume of 5-10mL.

Reversed phase type silicas and nonpolar adsorption media usually are conditioned with a water-miscible organic solvent such as methanol, followed by water or an aqueous buffer. Methanol wets the surface of the sorbent and penetrates bonded alkyl phases, allowing water to wet the silica surface efficiently.

Sometimes a *pre-conditioning solvent* is used before the methanol step. This solvent is usually the same as the elution solvent (see step 5), and is used to remove any impurities on the SPE tube that could interfere with the analysis, and may be soluble only in a strong elution solvent.

Normal phase type SPE silicas and polar adsorption media usually are conditioned in the organic solvent in which the sample exists.

Ion exchange packings that will be used for samples in nonpolar, organic solvents should be conditioned with the sample solvent. For samples in polar solvents, use a water-miscible organic solvent, then an aqueous solution with the proper pH, organic solvent content, and salt concentration.

To ensure that the SPE packing does not dry between conditioning and sample addition, allow about 1mm of the last conditioning solvent to remain above the top tube frit or above the surface of the disk. If the sample is to be introduced from a reservoir or filtration tube, add an additional 0.5mL of the final conditioning solution to a 1mL SPE tube, 2mL to a 3mL tube, 4mL to a 6mL tube, and so on. This prevents the tube from drying out before the sample actually reaches the tube. If the packing dries before the sample is added, repeat the conditioning procedure. Flush buffer salts from the tube with water before reintroducing organic solvents. If appropriate, attach the sample reservoir at this time using a tube adapter.

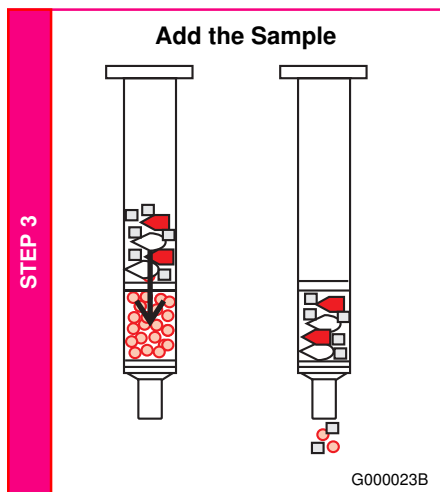

Accurately transfer the sample to the tube or reservoir, using a volumetric pipette or micropipette. The sample must be in a form that is compatible with SPE.

Total sample volume can range from microliters to liters (see step 1). When excessive volumes of aqueous solutions are extracted, reversed phase silica packings gradually lose the solvent layer acquired through the conditioning process. This reduces extraction efficiency and sample recovery. For samples >250mL, add small amounts of water-miscible solvents (up to 10%) to maintain proper wetting of reversed phase packings. Maximum sample capacity is specific to each application and the conditions used. If recoveries are low or irreproducible, test for analyte breakthrough using the following technique:

Attach two conditioned SPE tubes of the same packing together using an adapter. Pass the sample through both tubes. When finished, detach each tube and elute it separately. If the analyte is found in the extract of the bottom tube, the sample volume is too great or bed weight is too small, resulting in analyte breakthrough.

To enhance retention of appropriate compounds on the packing, and elution or precipitation of unwanted compounds, adjust the pH, salt concentration, and/or organic solvent content of the sample solution. To avoid clogging SPE tube frits or the SPE disk, pre-filter or centrifuge samples prior to extraction if possible.

Slowly pass the sample solution through the extraction device, using either vacuum or positive pressure. The flow rate can affect the retention of certain compounds. Generally, the flow rate should not exceed 2mL/min for ion exchange SPE tubes, 5mL/min for other SPE tubes, and may be up to 50mL/min for disks. Dropwise flow is best, when time is not a factor.

For some difficult sample matrices, additional pretreatment may be necessary. See Sample Pretreatment on the next page.

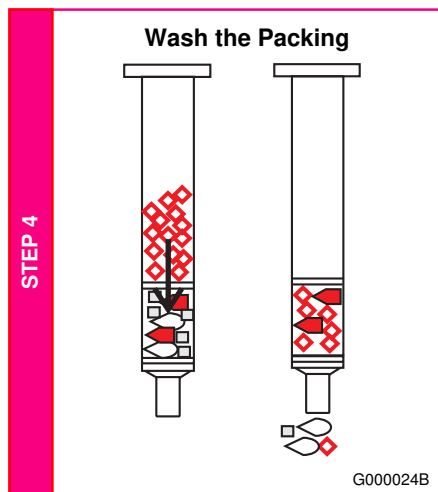

If compounds of interest are retained on the packing, wash off unwanted, unretained materials using the same solution in which the sample was dissolved, or another solution that will not remove the desired compounds. Usually no more than a tube volume of wash solution is needed, or 5-10mL for SPE disks.

To remove unwanted, weakly retained materials, wash the packing with solutions that are stronger than the sample matrix, but weaker than needed to remove compounds of interest. A typical solution may contain less organic or inorganic salt than the final eluant. It also may be adjusted to a different pH. Pure solvents or mixtures of solvents differing sufficiently in polarity from the final eluant may be useful wash solutions (see Table A).

If you are using a procedure by which compounds of interest are not retained on the packing, use about one tube volume of the sample solvent to remove any residual, desired components from the tube, or 5-10mL to remove the material from a disk. This rinse serves as the elution step to complete the extraction process in this case.

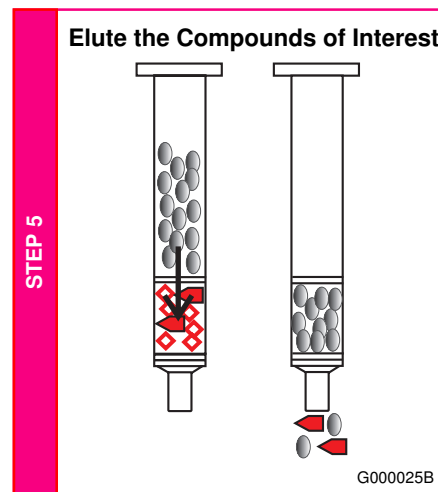

Rinse the packing with a small volume (typically 200µL to 2mL depending on the tube size, or 5-10mL depending on the disk size) of a solution that removes compounds of interest, but leaves behind any impurities not removed in the wash step. Collect the eluate and further prepare as appropriate.

Two small aliquots generally elute compounds of interest more efficiently than one larger aliquot. Recovery of analytes is best when each aliquot remains in contact with the tube packing or disk for 20 seconds to 1 minute. Slow or dropwise flow rates in this step are beneficial.

Strong and weak elution solvents for adsorbed compounds in SPE are described in Table A.

Table A. Characteristics of Solvents Commonly Used in SPE

Polarity		Solvent	Miscible in Water?
Nonpolar ↓ Polar	Strong Reversed Phase ↑	Hexane	No
		Isooctane	No
		Carbon tetrachloride	No
		Chloroform	No
		Methylene chloride (dichloromethane)	No
		Tetrahydrofuran	Yes
		Diethyl ether	No
	Weak Normal Phase ↓	Ethyl acetate	Poorly
		Acetone	Yes
		Acetonitrile	Yes
		Isopropanol	Yes
		Methanol	Yes
		Water	Yes
		Acetic acid	Yes

Sample Pretreatment

In addition to ensuring proper pH of the sample (see *The Role of pH in SPE* on page 5), you should consider other sample pretreatment needs. The following section describes how some difficult sample matrices should be pretreated before being applied to the SPE device:

Liquids

Biological Matrices

Serum, plasma, and whole blood: Serum and plasma samples may not need to be pretreated for SPE. In many cases, however, analytes such as drugs may be protein-bound, which reduces SPE recoveries. To disrupt protein binding in these biological fluids, use one of the following methods for reversed phase or ion exchange SPE procedures:

- Shift pH of the sample to extremes (pH < 3 or pH > 9) with acids or bases in the concentration range of 0.1M or greater. Use the resulting supernatant as the sample for SPE.
- Precipitate the proteins using a polar solvent such as acetonitrile, methanol, or acetone (two parts solvent per one part biological fluid is typical). After mixing and centrifugation, remove the supernatant and dilute with water or an aqueous buffer for the SPE procedure.
- To precipitate proteins, treat the biological fluid with acids or inorganic salts, such as formic acid, perchloric acid, trichloroacetic acid, ammonium sulfate, sodium sulfate, or zinc sulfate. The pH of the resulting supernatant may be adjusted prior to use for the SPE procedure.
- Sonicate the biological fluid for 15 minutes, add water or buffer, centrifuge, and use the supernatant for the SPE procedure.

Urine: Urine samples may not require pretreatment for reversed phase or ion exchange SPE, but often is diluted with water or a buffer of the appropriate pH prior to sample addition. In some cases, acid hydrolysis (for basic compounds) or base hydrolysis (for acidic compounds) is used to ensure that the compounds of interest are freely solvated in the urine sample. Usually a strong acid (e.g. concentrated HCl) or base (e.g. 10M KOH) is added to the urine. The urine is heated for 15-20 minutes, then cooled and diluted with a buffer, and the pH adjusted appropriately for the SPE procedure. Enzymatic hydrolysis that frees bound compounds or drugs also may be used.

Cell Culture Media

Cell culture media may be used without pretreatment. Some methods may require dilution of the media with water or buffer at the proper pH to ensure that the analyte is freely solvated in the sample. If a particulate-laden cell culture medium is difficult to pass through the SPE device, it may need to be vortexed and centrifuged prior to SPE. Most SPE procedures for cell culture media are done using reversed phase or ion exchange methods.

Milk

Milk generally is processed under reversed phase or ion exchange SPE conditions. The sample may be diluted with water, or with mixtures of water and a polar solvent such as methanol (up to 50%). Some procedures may require precipitation of proteins by treatment with acid (typically HCl, H₂SO₄, or trichloroacetic acid). After precipitation, the sample is centrifuged and the supernatant is used for SPE.

Water Samples

Drinking water, groundwater, and wastewater samples may be extracted directly by SPE, as long as they are not heavily laden with solid particles. Groundwater and wastewater samples might need to be filtered prior to the SPE procedure. Filtering may reduce recoveries if compounds of interest are bound to the removed particles. If possible, do not filter the sample. Pass the unfiltered sample directly through the SPE device and, during elution, allow the solvent to pass through the particles on the adsorbent bed. This will improve recoveries, since particle-bound compounds of interest will be recovered using this process. In most cases, water samples are used with reversed phase or ion exchange SPE procedures.

Wine, Beer, and Aqueous Beverages

Aqueous and alcoholic beverages may be processed for SPE without pretreatment under reversed phase or ion exchange conditions. For reversed phase procedures, if alcohol content is high, dilution with water or buffer to <10% alcohol may be required. If necessary, solids in the sample can be removed by centrifugation or filtration prior to SPE.

Fruit Juices

Fruit juices typically are processed without pretreatment or are centrifuged for reversed phase or ion exchange SPE. If centrifuged, the resulting supernatant is used for the SPE procedure. Viscous juices may need to be diluted with water or buffer at the proper pH.

Liquid Pharmaceutical Preparations

Because liquid pharmaceuticals are mainly aqueous, these samples generally are processed by reversed phase or ion exchange SPE. If the preparation is viscous, dilution with water or an appropriate buffer may be necessary. Organic extracts of the preparation may be processed using normal phase SPE.

Oils

Hydrocarbon or fatty oils are commonly processed under normal phase conditions, because they cannot be diluted with water. The diluent is usually a mid-polar to nonpolar solvent such as hexane or a chlorinated solvent. The diluted sample is passed through a normal phase bonded silica or adsorption medium, and the sample is collected as it passes through. The compound of interest should pass through unretained, while impurities remain in the adsorbent. If the compound of interest is retained on the packing, successive washes of the SPE packing with increasingly polar solvents, or with mixtures

of the diluent with a polar solvent, are performed until the analyte is recovered in one of the fractions. For collecting oil in water samples, reversed phase SPE is used.

Solids

Soil and Sediment

Soil and sediment samples typically are extracted with mid-polar to nonpolar solvents via Soxhlet extraction or sonication. The resulting extracts are then processed by normal phase SPE to remove interferences. The cleaned extracts then can be evaporated and reconstituted with another solvent for additional SPE (reversed phase, ion exchange, or normal phase) if necessary. If extraction efficiency of the compound of interest is pH-dependent, soil and sediment samples may need to be homogenized with water at the appropriate pH prior to extraction and SPE cleanup. In some cases, small amounts of soil or sediment can be homogenized with an appropriate solvent and then passed through the SPE device without pretreatment, as long as the particles do not clog the device. The analyte is then eluted with the appropriate solvent by passing it directly through any particles that rest on the SPE tube packing or disk.

Plant Tissues, Fruits, Vegetables, and Grains

Plant tissues, fruits, vegetables, and commodities such as animal feeds and grains are homogenized either in water, in a polar organic solvent (e.g. methanol or acetonitrile), or in mixtures of water with these solvents, for reversed phase or ion exchange cleanup procedures. After centrifugation or filtration to remove the precipitated proteins and solids, the pH of the sample may need to be adjusted. The analyte may adsorb onto the SPE packing or may simply pass through, free from interferences. The sample also may be homogenized with a mid-polar to nonpolar solvent for normal phase SPE procedures. Again, the sample may need to be centrifuged or filtered prior to SPE.

Meat, Fish, and Animal Tissues

Meat, fish, and other tissues can be processed in the same manner as described above for solid fruits and vegetables. In addition to homogenization with water, sample preparation for reversed phase and ion exchange SPE procedures may also involve hydrolysis or digestion of the meat or tissue with acid (typically HCl or trichloroacetic acid) or saponification with base (e.g. NaOH). Enzymatic hydrolysis also may be used. The sample can then be centrifuged and the supernatant used for the SPE procedure. Tissue extracts obtained with mid-polar to nonpolar solvents can be processed using normal phase procedures.

Tablets and Other Solid Pharmaceutical Preparations

Tablets and solid pharmaceutical preparations should be crushed into a fine powder, then extracted or homogenized with water or an appropriate buffer for reversed phase and ion exchange SPE procedures. A mid-polar to nonpolar solvent is used for normal phase cleanup procedures.

Hardware and Accessories for Processing Samples

SPE tubes can be processed individually using a single tube processor (Figure A) or with a syringe and an adapter (Figure B). The liquid sample is placed in the SPE tube, and the processor or syringe is used to provide positive pressure to force the liquid through the tube. Positive pressure from an air or nitrogen line also may be used to force the solutions through the tube.

Figure A. Single Tube Processor

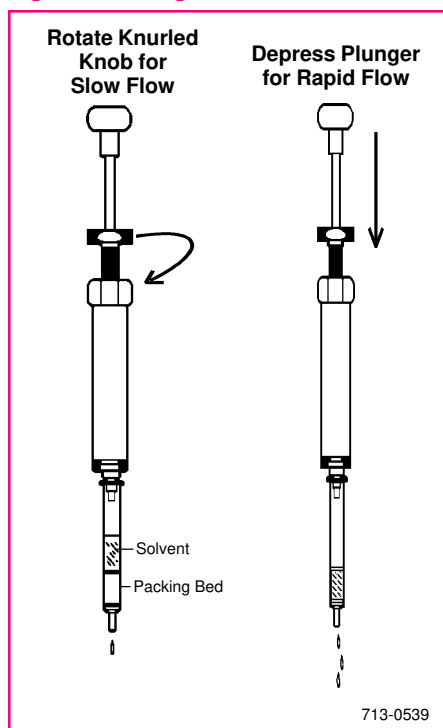
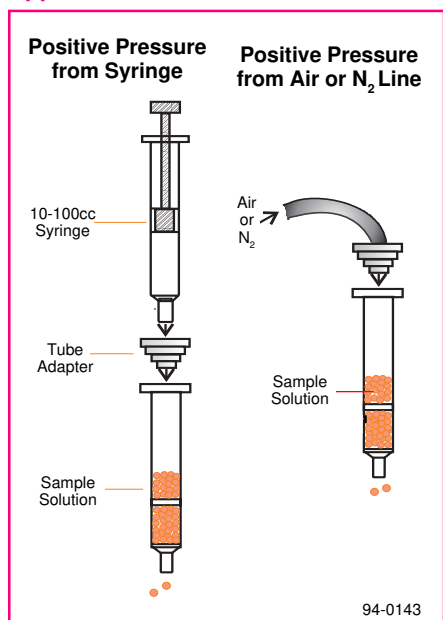

Figure B. Process Using Applied Pressure



A solution also can be processed through a single SPE tube using a vacuum flask and rubber stopper (Figure C). The vacuum pulls a solution through the SPE tube. The solution then can be collected in a test tube located inside the flask.

Several SPE tubes can be processed using a centrifuge (Figure D). The solutions are placed in the SPE tubes and the centrifuge forces the solutions through the tubes into test tubes. Appropriate spin rates must be determined; they can vary depending on the type and mass of the packing in the tube and the volume of sample. For sample addition, follow the recommended flow rates discussed in step 3 (page 8).

Figure C. Configuration Using a Vacuum Flask

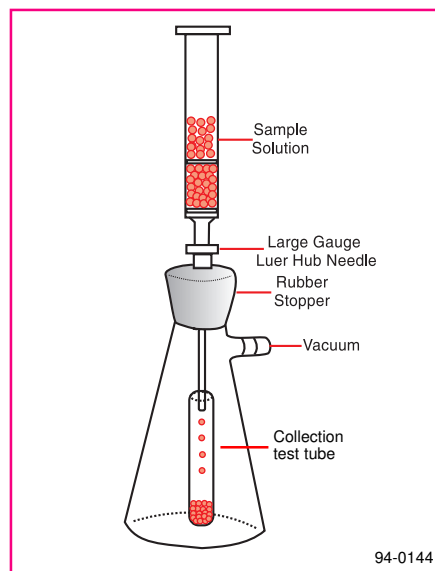
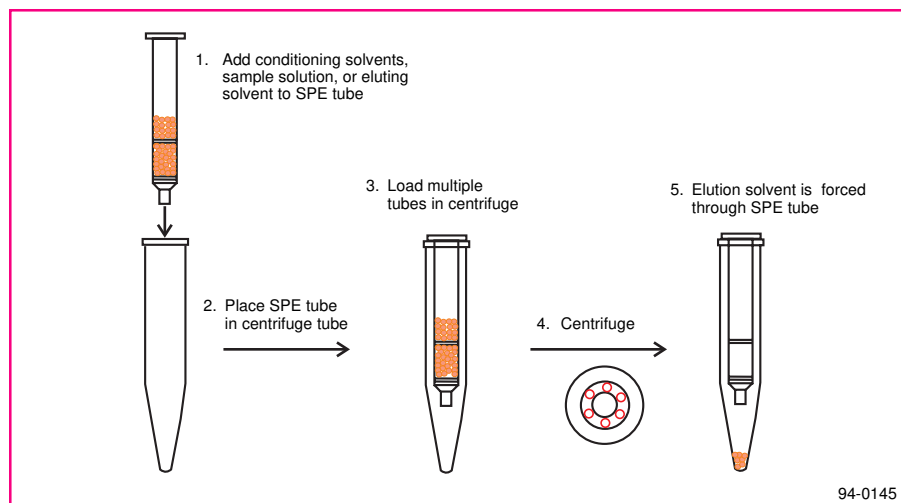

Figure D. Processing Several Tubes Using a Centrifuge



Multiple tubes can be processed simultaneously using a 12- or 24-port vacuum manifold. Supelco offers two types of Visiprep™ SPE vacuum manifolds—a standard lid version and a disposable liner version.

- Our *standard lid manifold* (Figure E) has unique flow control valves that allow easy control of flow through each SPE tube. Reusable stainless steel needle guides direct the sample into the glass basin below.
- Valves in the lid of the *DL manifold* (Figure F) contain a disposable Teflon® liner that directs the sample into the glass basin. The liner is conveniently disposable, is inert, and prevents cross-contamination in critical applications.

Both types of vacuum manifolds have a solvent resistant main vacuum gauge and valve used to monitor the vacuum and release the vacuum during processing.

Figure E. Visiprep Vacuum Manifold with Standard Lid



Figure F. Visiprep Vacuum Manifold with Disposable Liner



9950132

Unwanted solvents that collect in the bottom of the glass basin are pulled continuously through the gauge into the vacuum pump trap (Figure G) located between the pump and the manifold. This minimizes contamination by preventing buildup of unwanted waste solutions in the basin. The manifolds are equipped with an adjustable collection rack system that is placed inside the glass basin. The racks can be adjusted easily to accommodate many types and dimensions of collection vessels, such as small test tubes (10mm), large test tubes (16mm), volumetric flasks (1mL-10mL), and many types of autosampler vials.

Figure G. SPE Vacuum Pump Trap



9130181

The Preppy™ vacuum manifold (Figure H) is our simplest and most economical manifold. It too enables the analyst to simultaneously prepare up to 12 samples.

Figure H. Preppy Vacuum Manifold

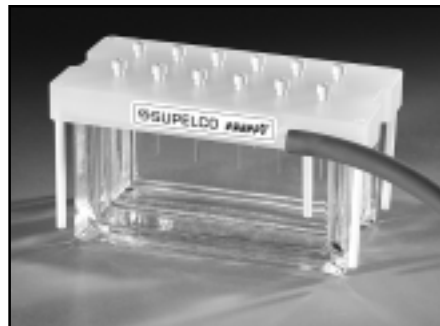

9970312

The Preppy manifold consists of a chemical-resistant cover and gasket, a glass basin, a vacuum release vent, 12 individual flow control valves with knurled tops, and stainless steel solvent guide needles. Two optional collection vessel racks are available: one holds both 1mL and 4mL autosampler vials, and the other holds 15mL or 20mL vials. Adapters are available for the 1mL-4mL vessel rack to hold mini-centrifuge tubes. An optional vacuum gauge/bleed valve assembly can be installed to allow precise control of the vacuum used with the Preppy manifold.

SPE tubes can be processed individually or can be combined using an adapter to provide different selectivities. Small volumes are processed directly in the SPE tube. Larger volumes can be accommodated by using a reservoir with an adapter. For very large samples, a large volume sampler is available, which allows unattended sample processing (Figure I).

Figure I. Visiprep Large Volume Sampler



9950147

For more information on these accessories, please refer to Supelco's general catalog.

Visidry™ drying attachments (Figure J), available with 12 ports and 24 ports, can be used to dry the tubes or evaporate and concentrate collected samples during the SPE procedure.

Figure J. Visidry Drying Attachment

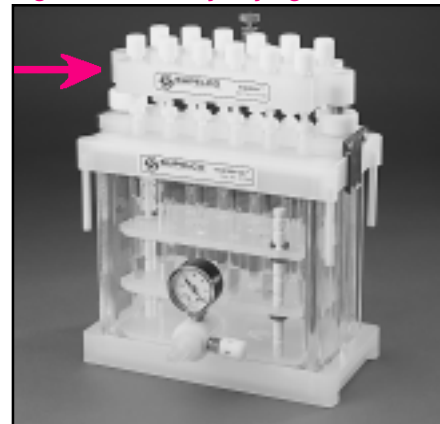

9950140

SPE disks can be processed on a vacuum filtration flask-type assembly (Figure K).

The ENVI-Disk Clamp (Figures L and M) is designed to eliminate potential leakage that is often observed with conventional flask clamps. The ENVI-Disk Holder (Figure N) is used when a standard filtration flask assembly is not available.

Figure K.

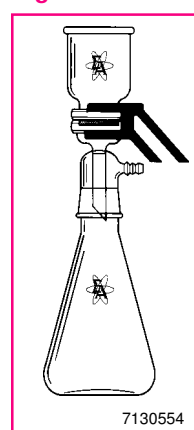

7130554

Figure L.



9960059

Figure M.



9960280

Figure N.



9950117

Sample Characteristics Determine Your SPE Procedure

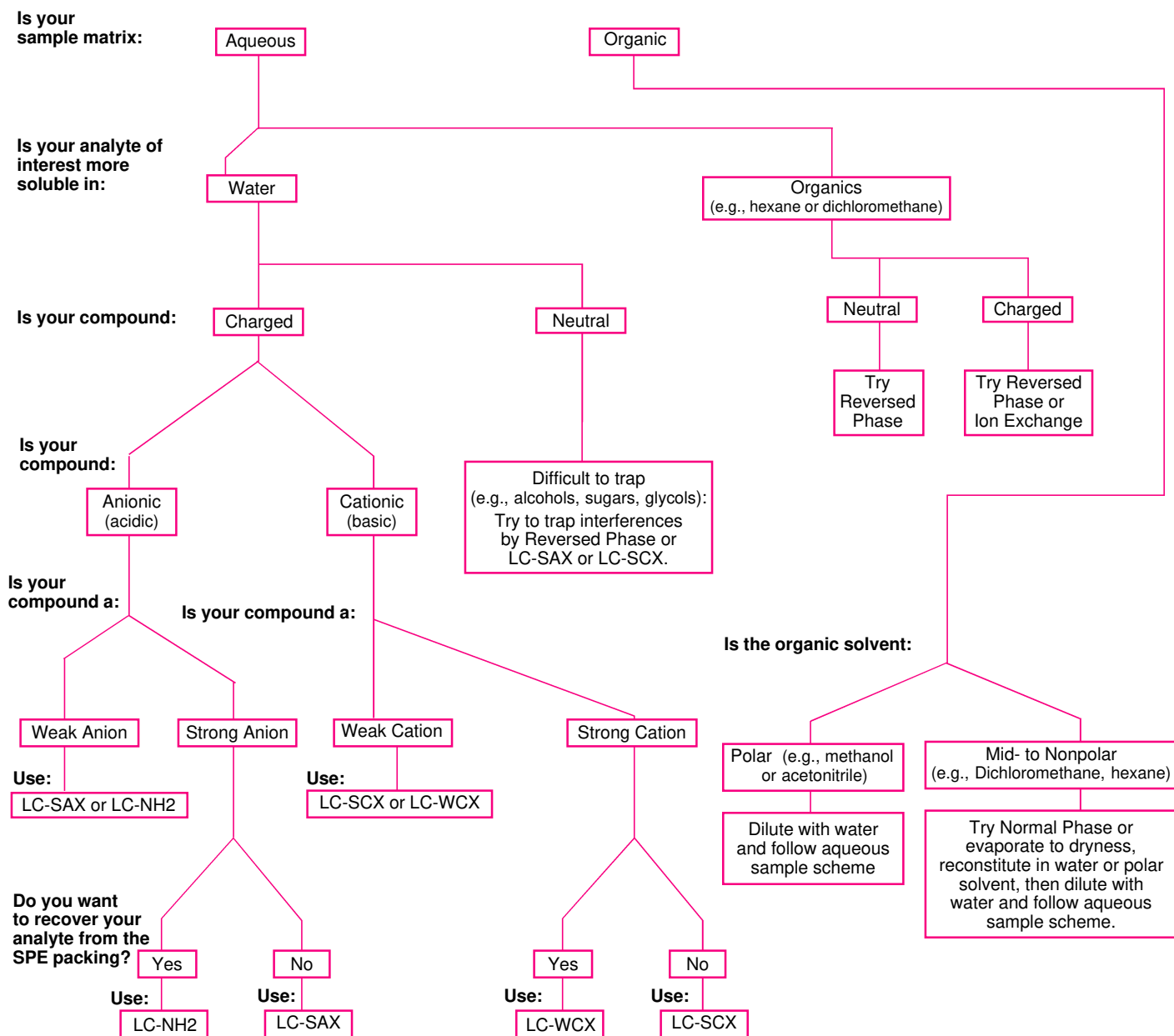

Choosing the proper SPE device for your application depends on:

- Sample volume
- Degree of contamination
- Complexity of sample matrix
- Quantity of compounds of interest
- Type and solvent strength of sample matrix

Patents

Visidry Drying Attachment – US patent 4,810,471; other patents pending.
Visiprep Vacuum Manifold – US patents D.289,861; 4,810,471; other patents pending.

Technical Service

If you need help in choosing the proper devices for your sample preparation applications, please contact our Technical Service chemists at 800-359-3041 or 814-359-3041.

Trademarks

ENVI, Hisep, Preppy, Supelclean, Visidry, Visiprep – Sigma-Aldrich Co.
Florisil – U.S. Silica Co.
Teflon – E.I. du Pont de Nemours & Co., Inc.

BULLETIN 910

For more information, or current prices, contact your nearest Supelco subsidiary listed below. To obtain further contact information, visit our website (www.sigma-aldrich.com), see the Supelco catalog, or contact Supelco, Bellefonte, PA 16823-0048 USA.

ARGENTINA · Sigma-Aldrich de Argentina, S.A. · Buenos Aires 1119 AUSTRALIA · Sigma-Aldrich Pty. Ltd. · Castle Hill NSW 2154 AUSTRIA · Sigma-Aldrich Handels GmbH · A-1110 Wien
BELGIUM · Sigma-Aldrich N.V./S.A. · B-2880 Bornem BRAZIL · Sigma-Aldrich Quimica Brasil Ltda. · 01239-010 São Paulo, SP CANADA · Sigma-Aldrich Canada, Ltd. · 2149 Winston Park Dr., Oakville, ON L6H 6J8
CZECH REPUBLIC · Sigma-Aldrich s.r.o. · 186 00 Praha 8 DENMARK · Sigma-Aldrich Denmark A/S · DK-2665 Vallensbaek Strand FINLAND · Sigma-Aldrich Finland/YA-Kemia Oy · FIN-00700 Helsinki
FRANCE · Sigma-Aldrich Chimie · 38297 Saint-Quentin-Fallavier Cedex GERMANY · Sigma-Aldrich Chemie GmbH · D-82041 Deisenhofen GREECE · Sigma-Aldrich (o.m.) Ltd. · Ilioupoli 16346, Athens
HUNGARY · Sigma-Aldrich Kft. · H-1067 Budapest INDIA · Sigma-Aldrich Co. · Bangalore 560 048 IRELAND · Sigma-Aldrich Ireland Ltd. · Dublin 24 ISRAEL · Sigma-Aldrich Chemicals Ltd. · Rehovot 76100
ITALY · Sigma-Aldrich s.r.l. · 20151 Milano JAPAN · Sigma-Aldrich Japan K.K. · Chuo-ku, Tokyo 103 KOREA · Sigma-Aldrich Korea · Seoul MALAYSIA · Sigma-Aldrich (M) Sdn. Bhd. · Selangor
MEXICO · Sigma-Aldrich Quimica S.A. de C.V. · 50200 Toluca NETHERLANDS · Sigma-Aldrich Chemie BV · 3330 AA Zwijndrecht NORWAY · Sigma-Aldrich Norway · Torshov · N-0401 Oslo
POLAND · Sigma-Aldrich Sp. z o.o. · 61-663 Poznań PORTUGAL · Sigma-Aldrich Quimica, S.A. · Sintra 2710 RUSSIA · Sigma-Aldrich Russia · Moscow 103062 SINGAPORE · Sigma-Aldrich Pte. Ltd.
SOUTH AFRICA · Sigma-Aldrich (pty) Ltd. · Jet Park 1459 SPAIN · Sigma-Aldrich Quimica, S.A. · 28100 Alcobendas, Madrid SWEDEN · Sigma-Aldrich Sweden AB · 135 70 Stockholm
SWITZERLAND · Supelco · CH-9471 Buchs UNITED KINGDOM · Sigma-Aldrich Company Ltd. · Poole, Dorset BH12 4QH
UNITED STATES · Supelco · Supelco Park · Bellefonte, PA 16823-0048 · Phone 800-247-6628 or 814-359-3441 · Fax 800-447-3044 or 814-359-3044 · email: supelco@sial.com

H

Supelco is a member of the Sigma-Aldrich family. Supelco products are sold through Sigma-Aldrich, Inc. Sigma-Aldrich warrants that its products conform to the information contained in this and other Sigma-Aldrich publications. Purchaser must determine the suitability of the product for a particular use. Additional terms and conditions may apply. Please see the reverse side of the invoice or packing slip. BLQ