

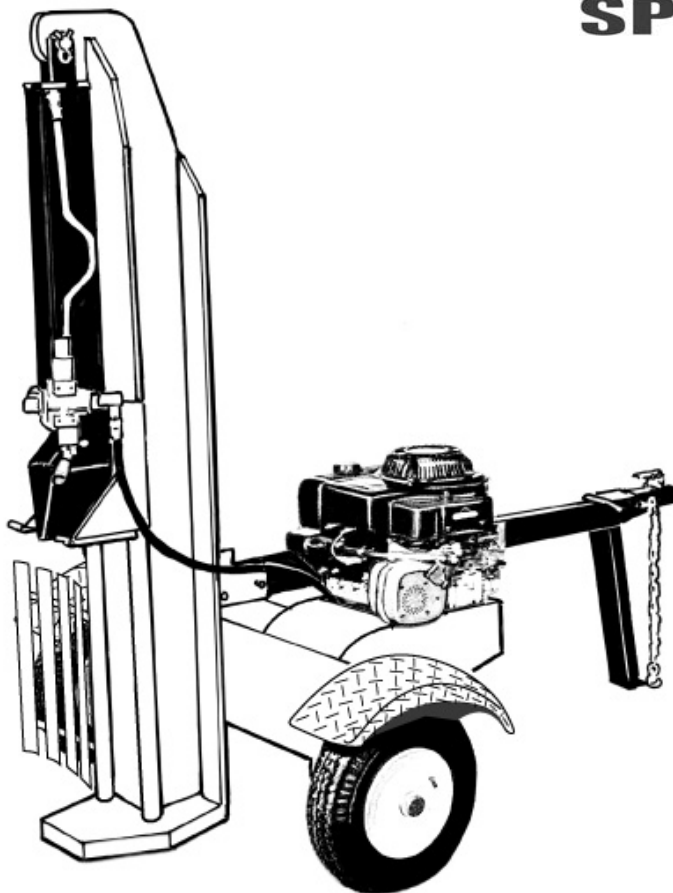

# 28 TON VERTICAL/HORIZONTAL LOG SPLITTER WITH ELECTRIC START

**SPLITMASTER**



**MODEL NO. 40123100**

## **Owner's Manual**

### **ASSEMBLY & OPERATING INSTRUCTIONS**



THIS SAFETY ALERT SYMBOL IDENTIFIES IMPORTANT SAFETY MESSAGES IN THIS MANUAL.



# Table of Contents

	Page(s)
Important Safety Information.....	1-6
Intended Use .....	1
Personal Protective Equipment .....	1
Safety Decals .....	1-2
General Safety .....	3
Preparation of the Log .....	3
Work Area .....	3
Operation of the Log Splitter .....	3-4
Repair and Maintenance Safety .....	4
Hydraulic Safety .....	5
Fire Prevention .....	5-6
Towing Safety .....	6
Assembly Instructions .....	7
Operating Instructions .....	7-9
Engine Oil Recommendations .....	8
Starting Instructions .....	8
Towing .....	9
Operation .....	9
Maintenance .....	9
Parts List .....	10-11
Parts Breakdown Illustration .....	12
Notes .....	13
Specifications .....	Back Cover



# IMPORTANT SAFETY INFORMATION



**WARNING:** Read and thoroughly understand all instructions and safety information before assembling or operating this log splitter. Failure to do so may cause serious injury or death. Do not allow anyone to operate this log splitter who has not read this manual. As with all power equipment, a log splitter can be dangerous if assembled or used improperly. Do not operate this log splitter if you have doubts or questions concerning safe operation. Call our customer service department at 1-800-525-8322 to address these concerns.

*Si no entiende ingles, se prefiere que busque alguien que interprete las instrucciones para usted.*

## INTENDED USE

**NEVER** use this log splitter for any other purposes than splitting wood. It is designed for this use **only**. Any other use can cause serious injury or death.

## PERSONAL PROTECTIVE EQUIPMENT



**BEFORE** operating this log splitter make sure that you wear safety gear such as goggles or safety glasses, steel toed shoes and tight fitting gloves (without loose cuffs or draw strings). Always wear a protective hearing device when operating this log splitter.

**NEVER** wear loose clothing or jewelry that can be caught by moving parts of the log splitter. Keep clothing and hair away from all moving parts when operating this log splitter.

## SAFETY DECALS

Make sure that all safety warning decals are in good condition and readable. Always replace missing or defaced decals. Write us or call 1-800-525-8322 and they will be sent to you at no charge.

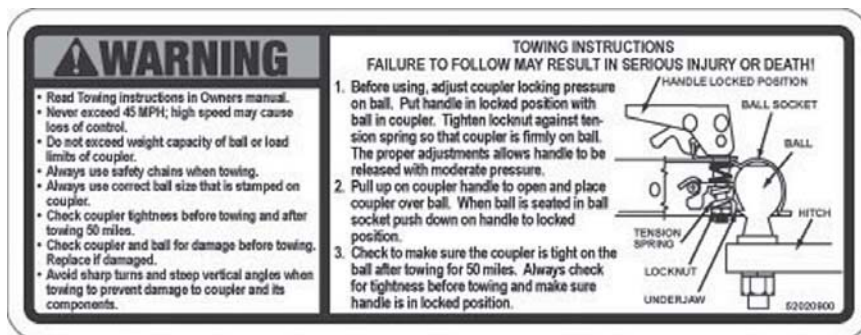

PART NUMBER: 52020000  
LOCATION: TOP, FRONT END OF TONGUE



# IMPORTANT SAFETY INFORMATION

**OPERATOR SAFETY**

**WARNING**



- Read and understand owner's manual thoroughly before operation. Failure to do so may result in serious injury. Manual also available online.
- Only one person should load and operate the log splitter. Keep all others away during operation. Never allow one person to operate the valve while another is positioning the log.
- Always position the log with hands on the sides of the log. Keep hands clear of ends.
- Do not operate log splitter under the influence of alcohol, drugs, or medication.
- Never check for leaks with your hands. High pressure fluid can escape through small holes and cause serious injury which could result in blood poisoning.
- Always stay in the operator zone when operating the log splitter.
- Keep hands, feet and clothing away from power driven parts.
- Do not attempt to step or reach over log splitter.
- Do not add gasoline while the engine is hot or running. Allow all spilled gas to evaporate before using log splitter.
- Always operate outdoors. Exhaust gases contain carbon monoxide. This odorless gas can be deadly when inhaled.

**CAUTION**

- Always wear safety glasses, safety shoes, and protective hearing devices during operation.
- Always shut off engine when leaving log splitter unattended, even for a short time.
- Always operate log splitter on level, dry, non-slippery surfaces. Keep off slopes.
- Keep work area clear of split wood, debris and other obstacles.
- Always split wood in the direction of the grain.

**OPERATING INSTRUCTIONS**

1. Read the Owner's manual for complete safety and operation instructions. Manual also available online.
2. Set up the log splitter in a clear, level area. Make sure that the suction port of the tank is always on the lower side of the log splitter.
3. Block the wheels. Lock the log splitter into either horizontal or vertical position.
4. Start the engine, refer to the Owner's manual and the Engine Operating and Maintenance manual.
5. Place a log on the beam against the foot plate. Position the log with hands on the sides. Make sure the log is securely placed against the foot plate and the beam.
6. Depress the valve handle so that the cylinder will drive the wedge/ram into the log.
7. Extend the cylinder until the log splits or to the end of the stroke. If the log has not completely split after the cylinder has reached the end of its extension, retract the cylinder.

Control Valve  
Retract ▲  
●  
▼ Extend

**For Responsive Service  
Call 1-800-525-8322**

51013200

PART NUMBER: 51018900  
LOCATION: TOP OF HYDRAULIC CYLINDER



PART NUMBER: 510105700  
LOCATION: TOP, FORWARD SECTION OF HYDRAULIC CYLINDER

**NOTICE**

KEEP TANK FILLED TO "OK" RANGE ON DIPSTICK. DO NOT FILL BEYOND "OK" RANGE. USE UNIVERSAL HYDRAULIC OIL OR DEXTRON II TRANSMISSION FLUID.



52023200

PART NUMBER: 52023200  
LOCATION: HYDRAULIC TANK LOWER TANK, RIGHT CORNER



# IMPORTANT SAFETY INFORMATION

## GENERAL SAFETY

**Failure to follow these instructions may result in serious injury or death.**

**NEVER** allow children to operate this log splitter. **NEVER** allow adults lacking proper instructions and understanding to operate this log splitter.

**KEEP** all people and pets a minimum of 10 feet away from your work area when operating this log splitter. Only the operator is to be near the log splitter during use.

If a helper is assisting in loading logs, **NEVER** actuate the control until the helper is clear of the work area.

**NEVER** operate the log splitter when under the influence of alcohol, drugs or medication.

**NEVER** allow a person who is tired or otherwise not alert to use your log splitter.

## PREPARATION OF THE LOG

Both ends of the log should be cut as square as possible to help prevent the log from riding out of the splitter during operation. Do not split logs greater than 26 in. in length.

## WORK AREA

**NEVER** operate the log splitter on slippery, wet, muddy or icy ground.

**ONLY** operate your log splitter on level ground. Operating on a slope could cause the log splitter to roll over or logs to fall off.

**NEVER** operate your log splitter in an enclosed area. Exhaust fumes contain carbon monoxide which can be deadly when inhaled.

**NEVER** attempt to move your log splitter over hilly or uneven terrain without a tow vehicle or adequate help.

**ALWAYS** block the wheels to prevent movement of the log splitter while in operation.

**ONLY** operate your log splitter in daylight or under good artificial light.

**ALWAYS** keep the work area clean. Remove split wood around your log splitter immediately so that you don't stumble over it.

## OPERATION OF THE LOG SPLITTER

**ONLY** operate the log splitter from the operator zone.

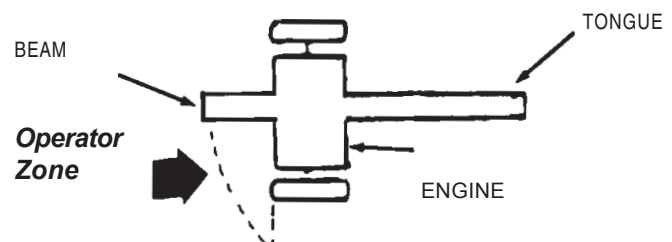



# IMPORTANT SAFETY INFORMATION

**KNOW** how to stop the log splitter and disengage the controls before operating it.

**NEVER** place hands or feet between the log and splitting wedge during forward or reverse stroke. Serious injury or death could result.

**NEVER** straddle or step over the log splitter during operation.

**NEVER** reach or bend over the log splitter to pick up a log.

**NEVER** try to split two logs on top of each other.

**NEVER** try to cross split a second log.

**NEVER** allow one person to operate the valve while another is positioning the log.

**NEVER** attempt to load your log splitter when the ram or wedge is in motion.

**ALWAYS** use your hand to operate the control lever on the valve. **NEVER** use your foot, a rope or any extension device.

**NEVER** move the log splitter while the engine is running. Shut off the engine even if you are leaving the log splitter for a short period of time.

**ALWAYS** avoid contact with the muffler and other hot areas of the engine during operation to prevent burns.

## REPAIR AND MAINTENANCE SAFETY

**NEVER** operate your log splitter when it is in poor mechanical condition or in need of repair.

Periodically check that all nuts, bolts, screws, hydraulic fittings and hose clamps are tightened.

**NEVER** alter your log splitter in any manner such as adding a rope or extension to the control lever or adding to the width or height of the wedge. Such alterations may cause your log splitter to be unsafe and will void the warranty.

Perform all recommended maintenance procedures before using your log splitter.

Replace all damaged or worn parts immediately.

**NEVER** tamper with the engine to run it at excessive speeds. The maximum engine speed is preset by the manufacturer and is within safety limits.

**ALWAYS** remove the spark plug wire before performing any service or repair on your log splitter.

**ALWAYS** check the level of hydraulic oil and engine oil before operation.

**ALL** replacement parts must meet manufacturer's specifications.



# IMPORTANT SAFETY INFORMATION

## HYDRAULIC SAFETY

The hydraulic system of your log splitter requires careful inspection along with the mechanical parts. Be sure to replace frayed, kinked, cracked or otherwise damaged hydraulic hose and components.

**NEVER** check for leaks of hydraulic fluid with your hand. Fluid escaping from a small hole can be almost invisible. Escaping fluid under pressure can have sufficient force to penetrate skin causing serious personal injury or even death. Leaks can be detected by passing a piece of cardboard over the suspected leak and looking for discoloration.

**ALWAYS** seek professional medical attention immediately if injured by escaping hydraulic fluid. Serious infection or reaction can develop if proper medical treatment is not administered immediately.

**ALWAYS** be sure to relieve all pressure by shutting off the engine and moving the valve control handle back and forth should it become necessary to loosen or remove any hydraulic fitting.

**NEVER** remove the cap from the hydraulic tank or reservoir while the log splitter is running. Hot oil under pressure could result in serious injury.

**NEVER** adjust the hydraulic valve. The pressure relief valve on your log splitter is preset at the factory. Only a qualified service technician should perform this adjustment.

## FIRE PREVENTION

**NEVER** operate your log splitter near a flame or spark. Hydraulic oil and gasoline are flammable and can explode.

**NEVER** fill the gas tank while the engine is hot or running. Allow the engine to cool before refueling.

**NEVER** smoke while operating or refueling your log splitter. Gas fumes can easily explode.

**ONLY** refuel your log splitter in a clear area with no gas fumes or spilled gas.

**ALWAYS** use an approved fuel container.

**ALWAYS** replace the gas cap securely.

If gasoline has spilled, move the log splitter away from the area of the spill and avoid creating any source of ignition until the spilled gas has evaporated.

**ALWAYS** take a Class B fire extinguisher with you when operating this log splitter in dry areas as a precautionary measure against possible flying sparks.

**ALWAYS** drain the fuel tank prior to storage to avoid the potential fire hazard.

**ALWAYS** store gasoline in an approved, tightly sealed container. Store the container in a cool, dry place.

**NEVER** store gasoline in the house or near a heating appliance.



# IMPORTANT SAFETY INFORMATION

## IMPORTANT NOTE:

This log splitter is equipped with an internal combustion engine and should not be used on or near any unimproved forest-covered, brush-covered or grass-covered land unless the engine's exhaust system is equipped with a spark arrester meeting applicable local or state laws (if any). If a spark arrester is used, it should be maintained in effective working order by the operator. In the state of California a spark arrester is required by law. Other states have similar laws. Federal laws apply on federal lands. A spark arrester muffler (optional by manufacturer) is available as an accessory at your nearest engine dealer. Always check the legal requirements in your area.

## TOWING SAFETY

**ALWAYS** check all local and state regulations regarding towing, licensing, and lights before towing your log splitter.

**ALWAYS** check before towing to make sure that the log splitter is correctly and securely attached to the towing vehicle and that the safety chains are secured to the hitch or bumper of the vehicle with enough slack to allow turning. Always use a Class I, 2" ball with this log splitter.

**NEVER** carry any cargo or wood on your log splitter.

**NEVER** allow anyone to sit or ride on your log splitter.

**ALWAYS** disconnect your log splitter from the towing vehicle before operating it.

**ALWAYS** be careful when backing up with your log splitter in tow. It could jackknife.

**ALWAYS** allow for added length of your log splitter when turning, parking, crossing intersections and in all driving situations.

**NEVER** exceed 45 mph when towing your log splitter. Towing the log splitter at speeds higher than 45 mph could result in loss of control, damage to the equipment, serious injury or death. Adjust towing speed for terrain and conditions. Be extra cautious when towing over rough terrain especially railroad crossings.



## ASSEMBLY INSTRUCTIONS

**NOTE:** This log splitter was partially assembled at the factory. Refer to the drawing and parts list should it become necessary to disassemble the unit for repair or replacement of parts.

- STEP 1:** Remove all the components from the crate. Inspect each piece for shipping damage. If any part is damaged, contact your dealer or delivering carrier.
- STEP 2:** Attach the tongue (3) to the tank/axle (2) as shown in the diagram using the two 1/2 in. NC x 4-1/2 in. hex cap screws (48), 1/2 in. lockwashers (47) and 1/2 in. NC hex nuts (46) from the hardware kit. Tighten. NOTE: Flatwashers are included in the hardware kit should it be necessary to use them as spacers to eliminate play between the tongue and the tank tongue mounting plate.
- STEP 3:** Remove the rubber covering from the two spindles on the tank/axle (2). The wheel bearing cups, bearing cones, grease seals and hub caps are already assembled. Bearing cones have been greased at the factory. Remove the hub cap (62) by prying it loose with a common tip screwdriver. Mount the wheels (54) to the spindles on the tank/axle (2) using the 3/4 in. light flatwasher (59) and 3/4 in. slotted nut (60) from the hardware kit. Tighten the nut until bearing play is removed and the wheel will still rotate freely. Install the cotter pin (61) and hub cap (62). Repeat step 4 for the other wheel.
- STEP 4:** Stand the beam (1) up on end. Make sure that the beam is stable. Remove the pivot pin (52) and the clip pin (53) from the tank/axle (2). Roll the axle/tongue assembly into position between the two tabs on the beam (1). Slide the pivot pin (52) through the holes and lock in place with the clip pin (53).
- STEP 5:** Connect the end of the 1/2 in. I.D. x 47 in. hydraulic hose (21) coming from the fitting (20) on the pump (9) to the fitting (75) on the valve (5).
- STEP 6:** Slide one hose clamp (50) on the end of the 3/4 in. x 32-1/2 in. hydraulic hose (49) that comes from the fitting on the tank/axle (2). Then connect the hose to the fitting (69) on the valve (5). Tighten hose clamp.
- STEP 7:** Attach the fenders (91) to the tank/axle (2) using the 1/4 in. NC x 3/4 in. hex cap screws (43), 1/4 in. flat washers (42) and 1/4 in. hex nuts (40). Tighten.
- STEP 8:** Remove the log catcher from the carton. Read the enclosed assembly instructions and attach the log catcher to the beam as shown in the diagram.

## OPERATING INSTRUCTIONS

### STEP 1: STARTING



**WARNING:** Read and thoroughly understand all instructions and safety information before operating this log splitter. Failure to do so may cause serious injury or death. Do not allow anyone to operate this log splitter who has not read this manual. As with all power equipment, a log splitter can be dangerous if assembled or used improperly. Do not operate this log splitter if you have doubts or questions concerning safe operation. Call our customer service department at 1-800-525-8322 to address these concerns.

**Si no entiende ingles, se prefiere que busque alguien que interprete las instrucciones para usted.**

**IMPORTANT:** The engine and hydraulic tank are shipped without oil. See the engine operating and maintenance instructions manual packed with the log splitter for the type of crankcase oil, fuel, etc. The engine manufacturer recommends lead-free gasoline only.



**CAUTION:** DO NOT START OR RUN THE ENGINE WITHOUT OIL IN THE HYDRAULIC RESERVOIR AND IN THE ENGINE.

**STEP 2:** The hydraulic reservoir should be filled with an SAE 20 hydraulic oil. If hydraulic oil is difficult to obtain, automatic transmission fluid can be substituted and should be used instead of hydraulic oil when temperatures are below 32 degrees. Use only clean oil and take care to prevent dirt from entering the hydraulic reservoir.



**CAUTION:** *WHEN TIGHTENING THE BREATHER CAP ON THE TANK, POINT THE HOLE AWAY FROM THE ENGINE AND THE OPERATOR ZONE.*

## **ENGINE OIL RECOMMENDATIONS**

For temperatures above 40 degrees F use an SAE 30W oil. Using mutigrade oil may increase oil consumption. Using SAE 30W oil below 40 degrees F will result in hard starting and possible engine bore damage. For temperatures below 40 degrees F use an SAE 10W-30 or SAE 5W-30 oil. Oil capacity is about 1-1/2 quarts (48 ounces; 1.4 liters).

## **DIRECTIONS FOR FILLING HYDRAULIC SYSTEM**

Fill the hydraulic reservoir with at least five gallons of hydraulic fluid. After the hydraulic reservoir and the engine crankcase are filled with oil, start the engine. The hydraulic pump should prime itself. With the engine running, move the hydraulic valve lever toward the wedge. This will cause the cylinder to extend and expel air. When the cylinder is fully extended, retract it. Repeat this procedure several times. An erratic movement of the cylinder indicates that there is still air in the system. More oil should then be added to bring the fluid level up to the "OK" range on the dipstick. Total hydraulic capacity is 31 quarts. **NOTE:** If the tank is overfilled, it will tend to expel oil from the breather cap when the cylinder is retracted. After adding more oil to the tank, cycle the cylinder again until it has a constant speed indicating that all oil has been expelled. Check the oil level in the reservoir again to make sure it is in the "OK" range.

## **STARTING INSTRUCTIONS**

**NOTE:** *REFER TO THE BRIGGS & STRATTON ENGINE OWNER'S MANUAL FOR COMPLETE INFORMATION ON STARTING, MAINTENANCE AND TROUBLE SHOOTING.*

- a) Move the throttle lever to "FAST." Always operate the engine with the throttle lever in the "FAST" position.
- b) Move choke control lever to "CHOKER" position.
- c) Push the Starter Switch to start the engine. For manual start, grasp the rope handle and pull slowly until resistance is felt. Then pull rapidly to start engine and avoid kickback.
- d) Allow the engine to warm up. If operating in warm weather, move the choke control lever toward "RUN" a short distance at a time over several seconds. For cold weather operation do this procedure over several minutes. Operate with choke lever in the "RUN" position.
- e) To stop engine, move the throttle lever to the "STOP" position.

**NOTE:** The engine maximum governed speed is preset at the factory at 3600 RPM no load speed. When splitting wood, the throttle should be set at the maximum setting to develop the horsepower required for the pump.

## TOWING

The log splitter is equipped with pneumatic tires, a Class I coupler (2 in. diameter ball required) and safety chains. Before towing, the safety chains must be secured to the hitch or bumper of the vehicle. Local regulations should be checked regarding licensing, lights, towing, etc. See also Towing Safety in the Safety Information section of this manual. Do not exceed 45 mph when towing this log splitter.

## OPERATION

**WARNING:** *ALWAYS WEAR SAFETY GLASSES WHEN OPERATING THIS LOG SPLITTER.*



**DANGER:** *KEEP HANDS AND FEET CLEAR OF RAM, STRIPPER PLATES AND BASE PLATE AT ALL TIMES.*

- 1) Set up the log splitter in a clear, level area and block the wheels. Make sure that the suction port on the tank is always on the lower side of the log splitter.
- 2) Place a log on the beam against the foot plate. Make sure that the log is securely on the foot plate and up against the beam. Always use extra care when splitting logs with unsquare ends.
- 3) Depress the valve handle so that the cylinder will drive the wedge into the log. Extend the cylinder until the log splits or to the end of its stroke. If the log has not completely split after the cylinder has reached the end of its extension, retract the cylinder.  
**IMPORTANT:** Leaving the valve in the "actuate" position at the end of the stroke may damage the pump.

**NOTE:** For operation in wooded areas, obtain a spark arrestor for the exhaust system. See the engine operating and maintenance manual and check with your authorized Briggs & Stratton service center. See also Prevent Fire in the Safety Information section of this manual.

**NOTE:** Output tonnage varies with altitude.

**IMPORTANT:** *TO EXTEND THE LIFE OF THE HYDRAULIC CYLINDER, AVOID "BOTTOMING OUT" WEDGE PLATE TO THE FOOT PIECE. TO CONFORM WITH INDUSTRY SAFETY RECOMMENDATIONS, THE WEDGE STOPS 2 INCHES FROM THE END OF THE STROKE.*

## MAINTENANCE

- 1) Consult the operating and maintenance instructions of the engine manufacturer for engine care and maintenance.
- 2) Always check the oil level of the hydraulic reservoir before operation. Operating the log splitter without an adequate oil supply will cause severe damage to the pump.
- 3) Change the oil filter after the first 25 hours of operation. Thereafter change the oil filter every hundred hours or seasonally, whichever comes first.
- 4) If the wedge becomes dull or nicked, it can be removed and sharpened. Remove the 1/2 in. diameter bolt that connects the wedge to the cylinder. The hose from the valve may need to be removed. While the log splitter is in the horizontal position, loosen the hose clamp and disconnect the hose from the valve. Carefully lift the cylinder to allow the wedge to slide forward. The wedge can now be lifted off and sharpened.
- 5) Clean the breather cap after 25 hours of operation. Clean it more often when operated in dusty conditions. To clean, remove the breather from the tank and flush with kerosene or liquid detergent to remove the dirt.
- 6) See also Repair and Maintenance Safety in the Safety Information section of this manual.
- 7) All replacement parts must meet manufacturer's specifications.

## PARTS BREAKDOWN FOR MODEL 40123100 LOG SPLITTER

REFERENCE NUMBER	PART NUMBER	DESCRIPTION	NUMBER REQUIRED
	40123100	28 Ton Vertical/Horizontal Log Splitter Complete	
1	401411B0	Black Beam (6" x 9")	1
2	401403S0	Tank/Axle	1
3	40126300	Tongue	1
4	390119B0	4-1/2" x 24" Hydraulic Cylinder	1
5	390406S0	Auto-Return Valve	1
6	40141700	Wedge	1
7	39053800	10.5 H.P.Electric Start Engine	1
8	39060100	Filter assembly (see list of equivalent filter elements on page 11)	1
9	39070900	16 gpm Pump	1
10	400824L0	Pump-Engine Coupler (3 pieces)	1
	400826L0	1/2" I.D. Coupler Half (pump side)	1
	400827L0	Coupler Spider	1
	400825L0	1" I.D. Coupler Half (engine side)	1
12	O/L	5/16" x 1" Hex Cap Screw (Grade 5)	4
14	O/L	5/16" NC Locknut	4
16	40032100	Square Engine Key	1
17	O/L	5/16" NC x 1-1/2" Hex Cap Screw (Grade 5)	3
19	39025900	1" X 12" Suction Hose	1
20	39034100	1/2" x 90° Street Elbow	1
21	39025700	1/2" I.D. x 47" Hydraulic Pressure Hose	1
22	39036300	3/4" NPT x 1" 90° Hose Fitting	1
23	39034900	3/4" x 2-1/2" Nipple	1
24	--	Ground Stand	1
25	07095800	5/16" Locking Pin for Ground Stand	1
26	O/L	M10 x 1.5 x 85mm Bolt	1
27	O/L	5/8" Lockwasher	2
28	O/L	5/8" NF Hex Nut	2
29	O/L	M10 x 1.5 Nut	3
31	07080900	7/8" Diameter x 2-5/8" Pin with 5/8" NF Thread	1
32	07090400	1/4" Lynch Pin	1
33	40034600	2" Hitch Coupler	1
34	O/L	10mm Washer	8
35	O/L	M10 x 1.5 x 115mm Bolt	1
36	O/L	M10 x 1.5 x 100mm Bolt	1
37	O/L	Safety Chain with 3/8 in. "S" Hook	2
40	O/L	1/4" NC Hex Nut for Fender	4
41	O/L	1/4" Lockwasher for Fender	4
42	O/L	1/4" Flatwasher for Fender	4
43	O/L	1/4" NC x 3/4" Hex Cap Screw for Fender	4
45	39037600	Dip Stick	1
46	O/L	1/2 in. NC Hex Nut	2
47	O/L	1/2 in. Lock Washer	3
48	O/L	1/2 in. NC x 4-1/2 in. Hex Cap Screw	2
49	39025000	3/4 in. I.D. x 32-1/2 in. Hydraulic Return Hose	1
50	39031600	Hose Clamp # 16	4
52	071022WC	5/8 in. 6-1/4 in. Pivot Pin	1
53	O/L	1/8 in. "R" Clip Pin	2

REFERENCE NUMBER	SKU NUMBER	DESCRIPTION	NUMBER REQUIRED
54	40034700	Pregreased Wheel Assembly Silver	2
--	40030900	Wheel Seal and Bearing Kit contains 1- grease seal, 2-bearing cone and 2-bearing cups	
55	--	Grease Seal	2
56	--	Bearing Cone	4
57	--	Bearing Cup	4
59	O/L	3/4" Light Flatwasher	2
60	17012000	3/4" NF Slotted Nut	2
61	O/L	1/8" x 1-1/2" Cotter Pin	2
62	40033200	Hub Cap	2
63	O/L	1/2" x 3" Grade 5 Hex Cap Screw	1
64	O/L	Clip Pin	2
65	07073100	Cylinder Pin with Clip Pins	1
67	39034700	Tube Fitting	2
68	39034600	1/2" Diameter Steel Tube	1
69	39032000	3/4 NPT x 3/4" 90° Fitting	1
70	39034300	1/2"-1/2" Hex Nipple	1
71	39031100	3/4"-1/2" Reducer Bushing	1
73	O/L	1/2" NC Hex Nut	1
74	40117400	1-1/4" I.D. Grommet	1
75	39030200	Swivel Elbow 90°	1
76	O/L	Drain Plug	1
78	48010800	12 Volt 275 CCA Battery	1
79	40141000	Battery Bar	1
80	O/L	1/4 in. x 7 in. UNC Hex Cap Screw	1
81	40118400	11/16 in. Grommet	1
82	O/L	Starter Boot (Medium Duty Starter Terminal Protector)	1
83	48021000	Solenoid	1
84	O/L	1/4 in. x 3/4 in. Truss Slotted Machine Screw	1
85	48020900	Starter Switch	1
86	48020400	Ground Wire	1
87	48020500	Battery Wire	1
88	48020600	Starter Wire	1
89	48020800	Switch Wire	1
90	48020700	Switch Power Wire	1
91	40140600	Diamond Plate Fender	2
92	40141600	Log Catcher	1
93	O/L	3/8 in. Lock Washer	4
94	O/L	3/8 in. Washer	2
95	O/L	3/8 in.-24 UNF x 3/4 in. Bolt	2
96	O/L	3/8 in. UNC x 1-1/2 in. Bolt	2
97	O/L	3/8 in. x- 16 UNC Nut	2
100	390429A0	Control Handle for Valve	1
101	39043400	Chain Link for Valve Handle	1
102	39044200	Spring Cap for Valve	1
--	39044300	Detent Assembly for Valve	1
103	39043500	Mounting Bracket for Valve	1
104	07042900	1/4" Clevis Pin	1
105	17111000	3/32" Straight Cotter Pin	1

O/L- Obtain locally. Common fasteners available through hardware and farm stores.

#### Repair Kits

39017100	"O" ring kit for cylinder 390119B0
390423E0	"O" ring kit for valve 390406S0
390720B0	"O" ring kit for pump 39070900

**MODEL NO. LS401231 LOG SPLITTER**

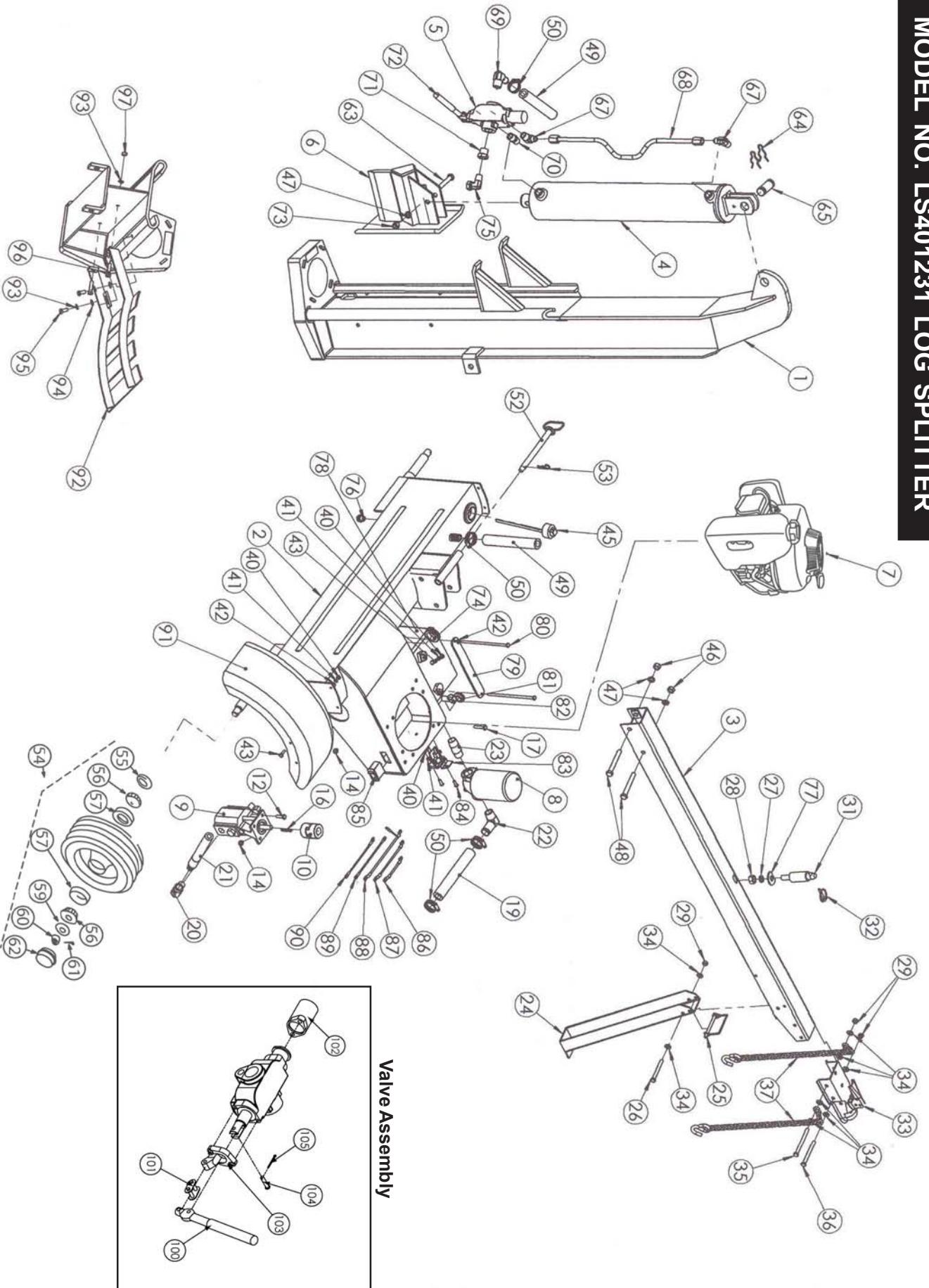

**MODEL NO. LS401231 LOG SPLITTER**

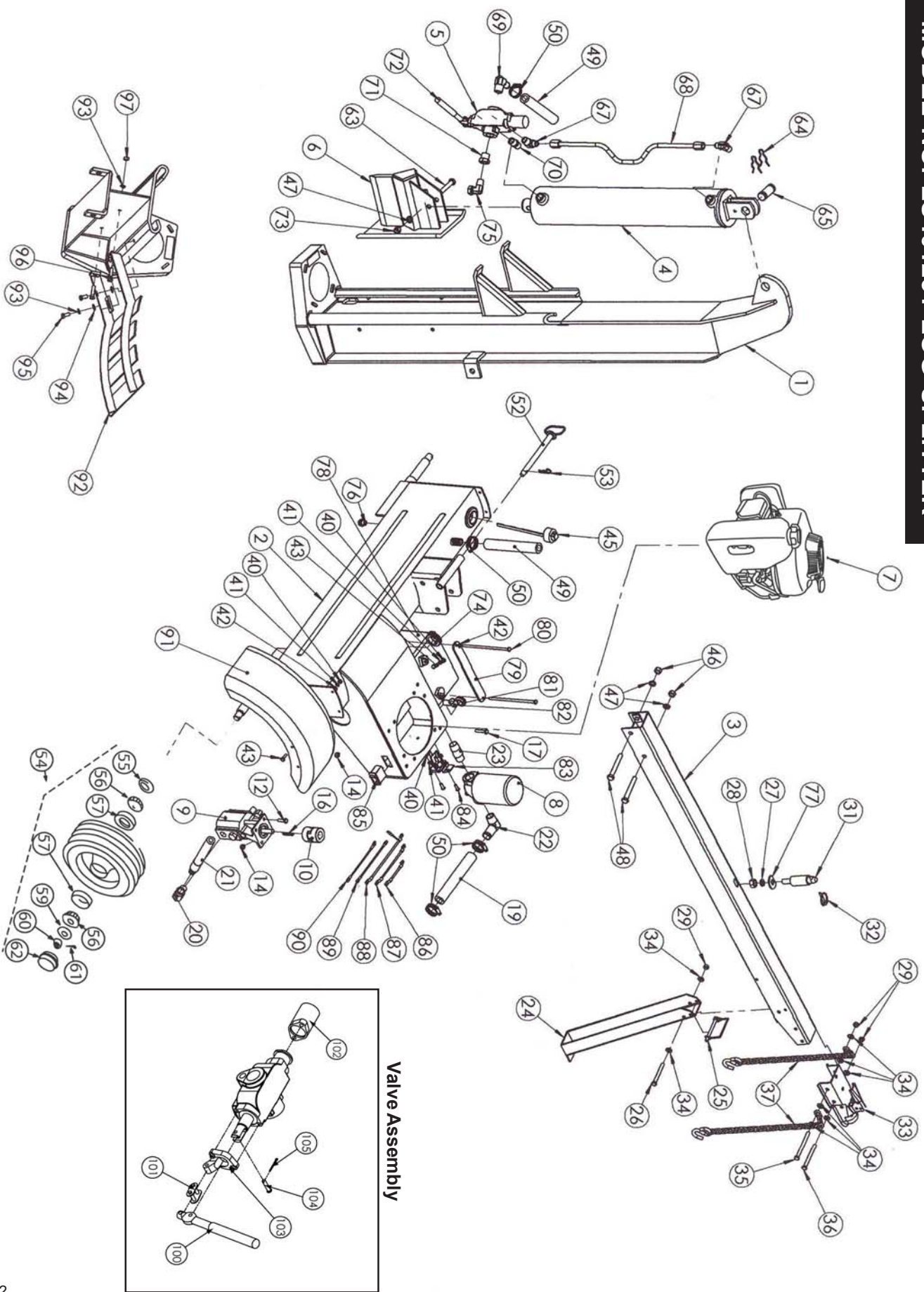

# == NOTES ==

Model No. \_\_\_\_\_

Serial No. \_\_\_\_\_

Date of Purchase \_\_\_\_\_

Place of Purchase \_\_\_\_\_

\_\_\_\_\_  
\_\_\_\_\_  
\_\_\_\_\_



# SPECIFICATIONS

Engine	10.5 HP Briggs & Stratton I/C with Electric Start
Pump	Two-Stage, 16 gpm
Cylinder	4-1/2 in. Diameter x 24 in. Stroke
Valve	Auto-Return
Maximum Splitting Force	28Tons
Maximum Log Length	26 in.
Cycle Time	12 Seconds
Wheels	4.80 x 8 in. Road Tires
Fenders	Diamond Plate
Wedge	7 in. High with Spreader Wings
Beam Size	6 in. x 9 in. with Built-In Log Cradle
Hydraulic Capacity	31 Quarts
Filter	Spin-On Replaceable Filter
Height	72 in. in Vertical Position 42 in. in Horizontal Position
Length	78 in.
Width	49 in.
Accessories	Log Catcher

\*Ideal case cycle time. Actual cycle time will vary depending on temperature, altitude, engine speed, pump efficiency, etc.



*A brand of Special Products Co.*  
 15000 W. 44th Ave. Golden Colorado 80403  
 303-279-5544 Toll Free USA 800-525-8322 Fax 303-278-3432  
 Email: [speeco@speeco.com](mailto:speeco@speeco.com) Web: [www.speeco.com](http://www.speeco.com)