

# PILATES

## 4500 JP

by **STAMINA**®

## Owner's Manual

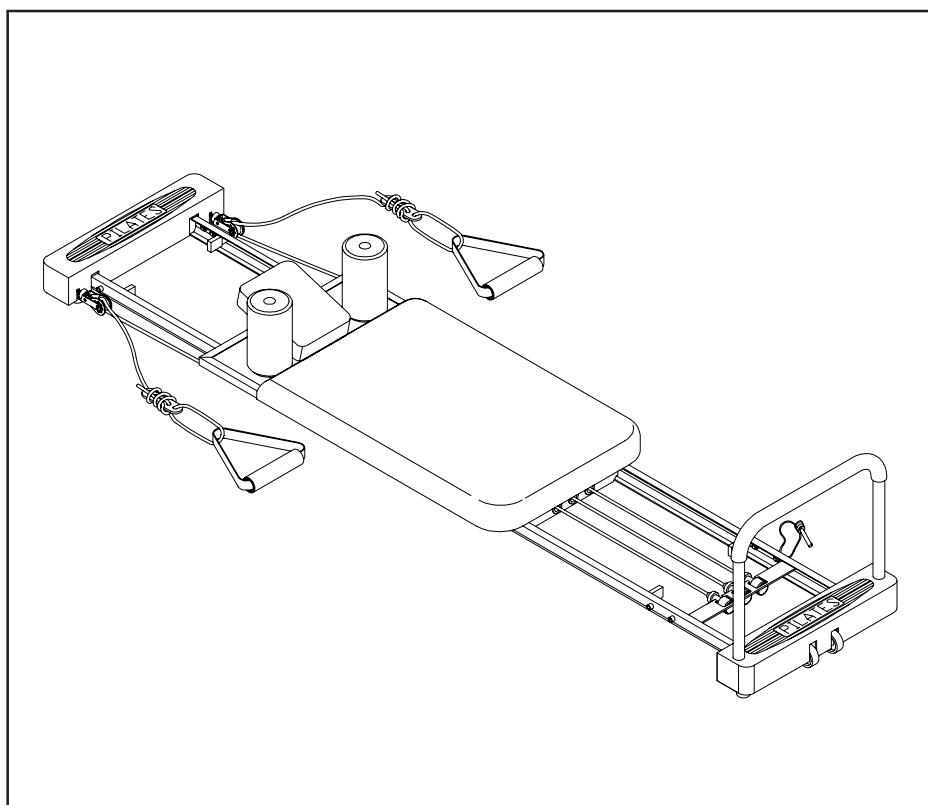

### ⚠ WARNING ⚠

Exercise can present a health risk. Consult a physician before beginning any exercise program with this equipment. If you feel faint or dizzy, immediately discontinue use of this equipment. Serious bodily injury can occur if this equipment is not assembled and used correctly. Serious bodily injury can also occur if all instructions are not followed. Keep others and pets away from equipment when in use. Always make sure all bolts and nuts are tightened prior to each use. Follow all safety instructions in this manual.

When calling for parts or service, please specify the following number.

**55-4285**

**Pat. No. D382,319**

**Other Patents Applied  
and Are Pending**

**MADE IN CHINA**

**Product May Vary Slightly  
From Pictured.**

#### **CAUTION:**

**Weight on this product should not exceed 300 lbs.**

**This Product is Produced Exclusively by**



**2040 N. Alliance, Springfield, MO 65803**

**Customer Service Number**

**1 (800) 375-7520**

**www.staminaproducts.com**

---

## TABLE OF CONTENTS

	Page		Page
Safety Instructions	2	Conditioning Guidelines	10
Before You Begin	4	Warm-up and Cool-Down	11
Hardware Illustrations	5	Product Parts Drawing	12
Assembly Instructions	6	Parts List	13
Storage	9	Warranty	14
Maintenance	9	Fax/Mail Ordering Form	15

---

### SAFETY INSTRUCTIONS

**WARNING:** To reduce the risk of serious injury, read the following Safety Instructions before using the **PILATES 4500 JP**.

1. Read all warnings posted on the **PILATES 4500 JP**.
2. Read this Owner's Manual and follow it carefully before using the **PILATES 4500 JP**. Make sure that it is properly assembled and tightened before use.
3. Keep children away from the **PILATES 4500 JP**. Do not allow children to use or play on the **PILATES 4500 JP**. Keep children and pets away from the **PILATES 4500 JP** when it is in use.
4. Set up and operate the **PILATES 4500 JP** on a solid level surface. Do not position the **PILATES 4500 JP** on loose rugs or uneven surfaces.
5. Inspect the **PILATES 4500 JP** for worn or loose components prior to use. Tighten/replace any loose or worn components prior to using.
6. Consult a physician prior to commencing an exercise program. If, at any time during exercise, you feel faint, dizzy, or experience pain, stop and consult your physician.
7. Follow your physician's recommendations in developing your own personal fitness program.
8. Always choose the workout which best fits your physical strength and flexibility level. Know your limits and train within them. Always use common sense when exercising.
9. Do not wear loose or dangling clothing while using the **PILATES 4500 JP**.
10. Care should be taken in mounting or dismounting the **PILATES 4500 JP**.
11. The **PILATES 4500 JP** should not be used by persons weighing over 300 pounds.
12. The **PILATES 4500 JP** should be used by only one person at a time.
13. The **PILATES 4500 JP** is for consumer use only. It is not for use in public or semipublic facilities.

**WARNING:** Before starting any exercise or conditioning program you should consult with your personal physician to see if you require a complete physical exam. This is especially important if you are over the age of 35, have never exercised before, are pregnant, or suffer from any illness. **READ AND FOLLOW THE SAFETY PRECAUTIONS. FAILURE TO FOLLOW THESE INSTRUCTIONS CAN RESULT IN SERIOUS BODILY INJURY.**

# CALL US FIRST



**CUSTOMER SERVICE NUMBER**  
**1 (800) 375-7520**

---

**THANK YOU FOR PURCHASING THE  
PILATES 4500 JP**

To help you get started, we have pre-assembled most of your  
PILATES 4500 JP at the factory with the exception  
of those few parts left unassembled for shipping purposes.  
Simply follow the few assembly instructions set forth in this manual.  
Within a few minutes you will be getting your body into shape and on your  
way to achieving a happier and healthier lifestyle.

Should you have any questions,  
please call our Customer Service Department toll-free number,  
**1 (800) 375-7520**  
Monday - Friday, 8:00 A.M. - 5:00 P.M., Central Time.

## BEFORE YOU BEGIN

Thank you for choosing the **PILATES 4500 JP**. We take great pride in producing this quality product and hope it will provide many hours of quality exercise to make you feel better, look better and enjoy life to its fullest.

Yes, it's a proven fact that a regular exercise program can improve your physical and mental health. Too often, our busy lifestyles limit our time and opportunity to exercise. The **PILATES 4500 JP** provides a convenient and simple method to begin your assault on getting your body in shape and achieving a happier and healthier lifestyle.

Before reading further, please review the drawing below and familiarize yourself with the parts that are labeled.

Read this manual carefully before using the **PILATES 4500 JP**.

Although Stamina tries to manufacture its products with the finest materials and uses the highest standards of manufacturing, occasionally a part that does not fit, is the incorrect size, or is otherwise inappropriate is found. Even with the highest inspection and quality controls in place these things will happen occasionally. Please do not return the product. For your convenience, Stamina has a Customer Service Department with a toll-free number. If a part is missing, does not fit, is the incorrect size, or is otherwise inappropriate, please call 1 (800) 375-7520 (in the U.S.) between 8:00 A.M. and 5:00 P.M. Central Time, Monday through Friday. Our operators will be able to assist you with your problem and the parts will be mailed directly to your house.

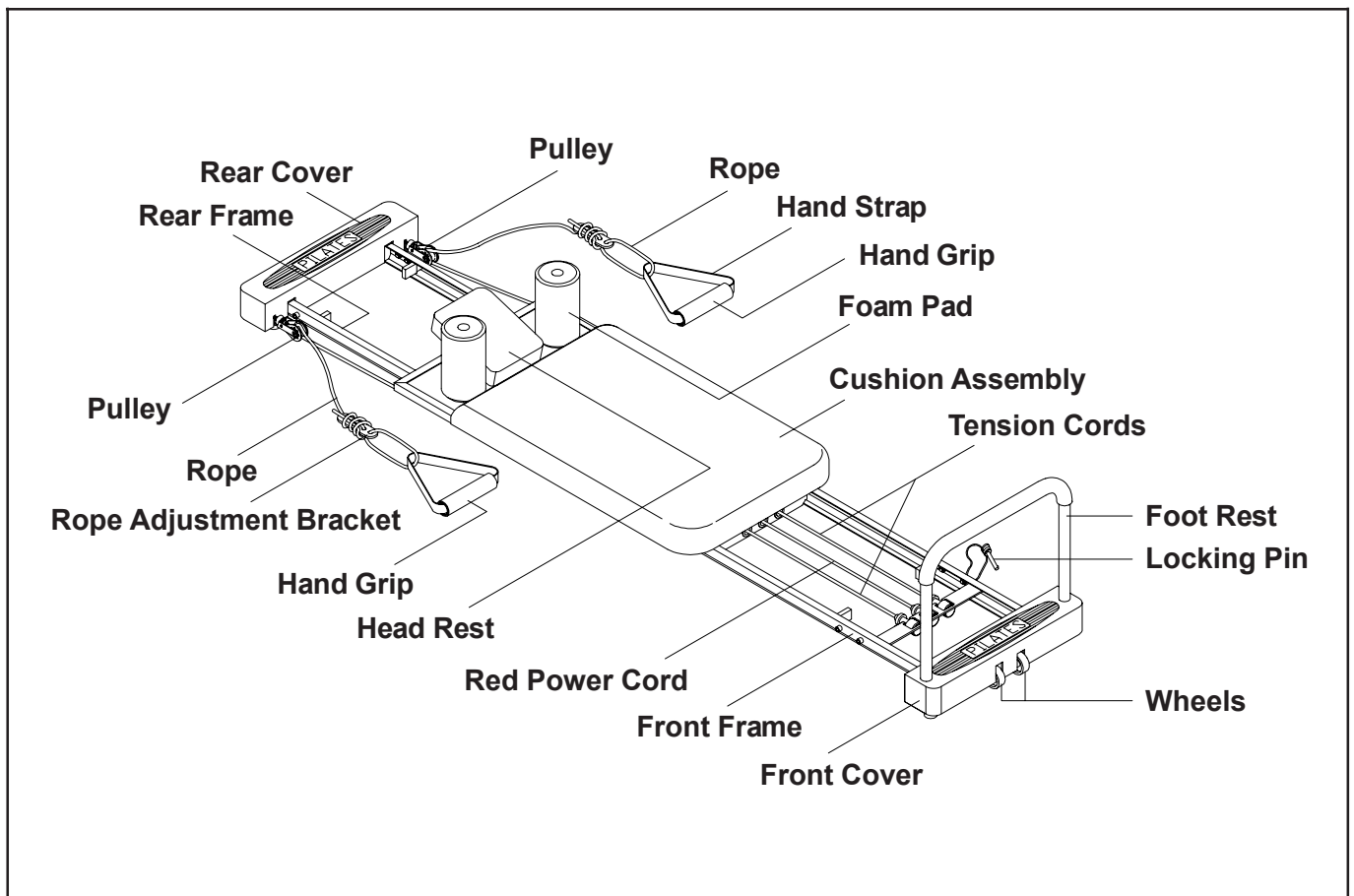

THE FOLLOWING TOOLS ARE REQUIRED FOR ASSEMBLY :

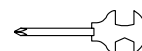

Combination Wrench

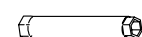

Socket Wrench

# HARDWARE ILLUSTRATIONS

This chart is provided to help identify some of the small parts used in the assembly of this product. This sheet may not include all the hardware needed to assemble your product. It is intended to be used as a guide to help simplify your assembly process.

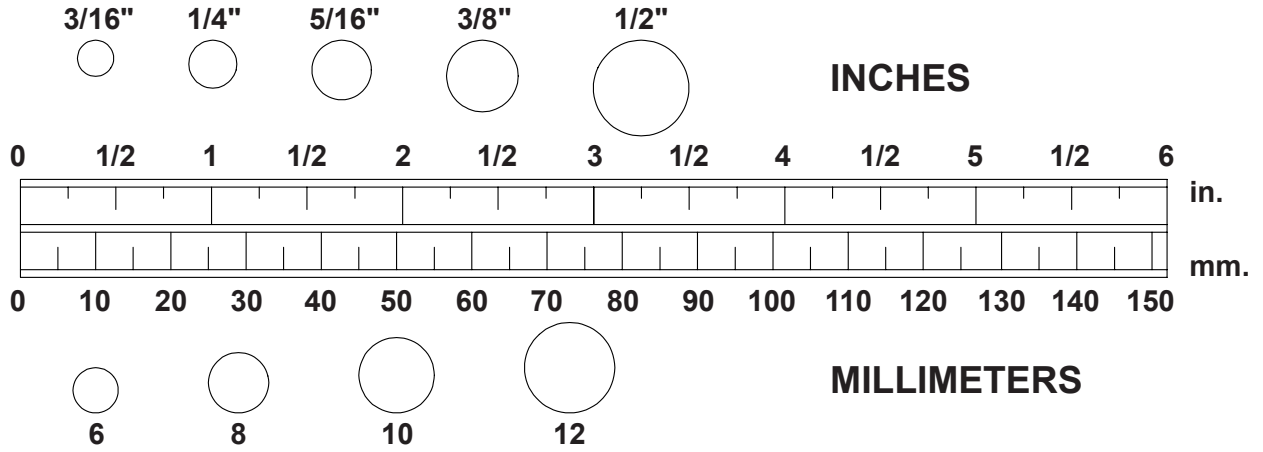

Place washers, the end of bolts or screws on the circles to check for the correct size. Use the small scale to check the sizes of bolts and screws.



**Acorn Nut**

**Standard Nut**

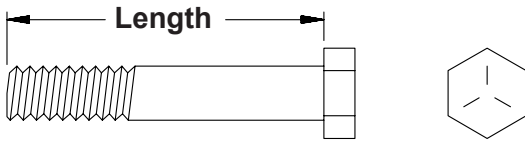

**Hex Head Bolt**

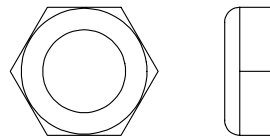

**Thin Nylock Nut**

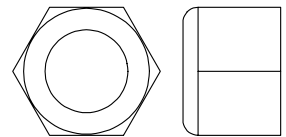

**Nylock Nut**

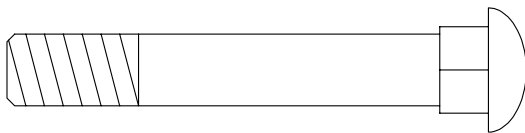

**Carriage Bolt**

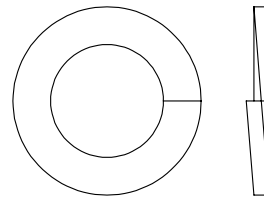

**Lock Washer**

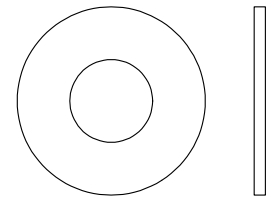

**Flat Washer**

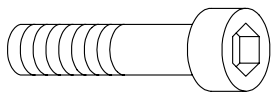

**Socket Head Screw**

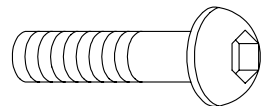

**Button Head Screw**

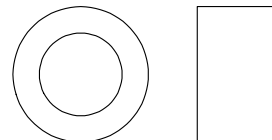

**Spacer**

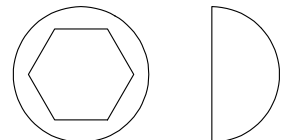

**Nut Cap**

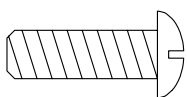

**Round Head Screw**

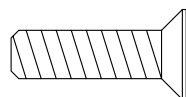

**Flat Head Screw**

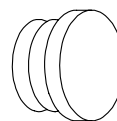

**Round Plug**

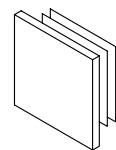

**Square Plug**

## ASSEMBLY INSTRUCTIONS

Place all parts from the box in a cleared area and position them on the floor in front of you. Remove all packing materials from your area and place them back into the box. Do not dispose of the packing materials until assembly is completed. Read each step carefully before beginning. If you are missing a part please call our toll-free number for assistance **1 (800) 375-7520** or e-mail us at: **parts@staminaproducts.com**

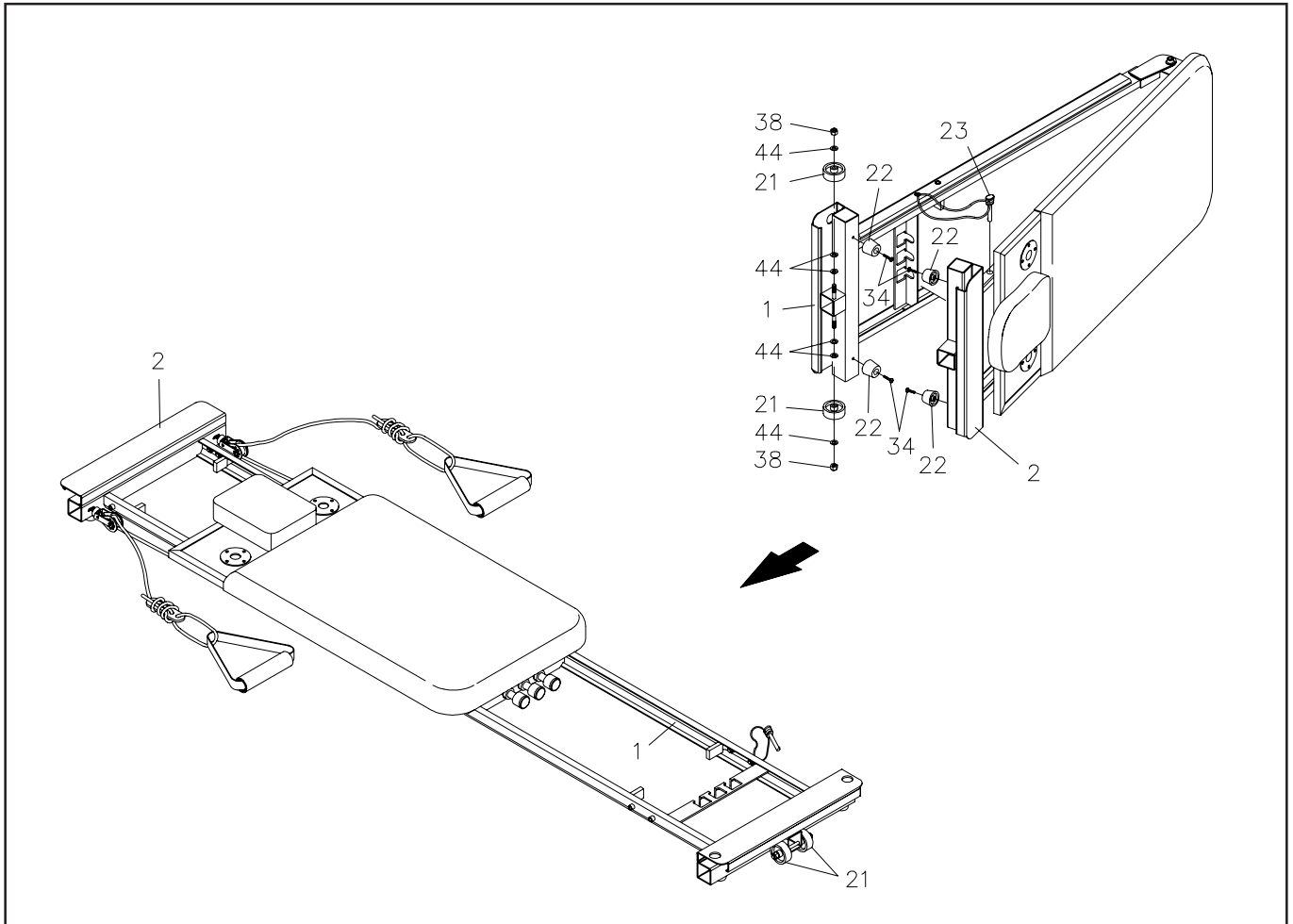

### STEP 1

Remove your **PILATES 4500 JP** from its packaging placing the product on its side, with the **LOCKING PIN(23)** side upward. Remove the **LOCKING PIN(23)** and unfold the **MAIN FRAME ASSEMBLY** separating the half that has the attached **LOCKING PIN(23)**. When completed, the frame should be separated approximately 3 feet at the end.

### STEP 2

Attach the four **RUBBER FEET(22)** to the **FRONT FRAME(1)** and **REAR FRAME(2)** with **SCREWS (M5 x 25mm)(34)**. Attach the **PLASTIC WHEELS(21)** onto the **FRONT FRAME(1)** with **WASHERS(M8)(44)** and **NYLOCK NUTS(M8)(38)**.

### STEP 3

Unfold your **PILATES 4500 JP** to a flat position by moving the **FRONT FRAME(1)** away from the platform end of the product in a clockwise position until fully extended.

## ASSEMBLY INSTRUCTIONS

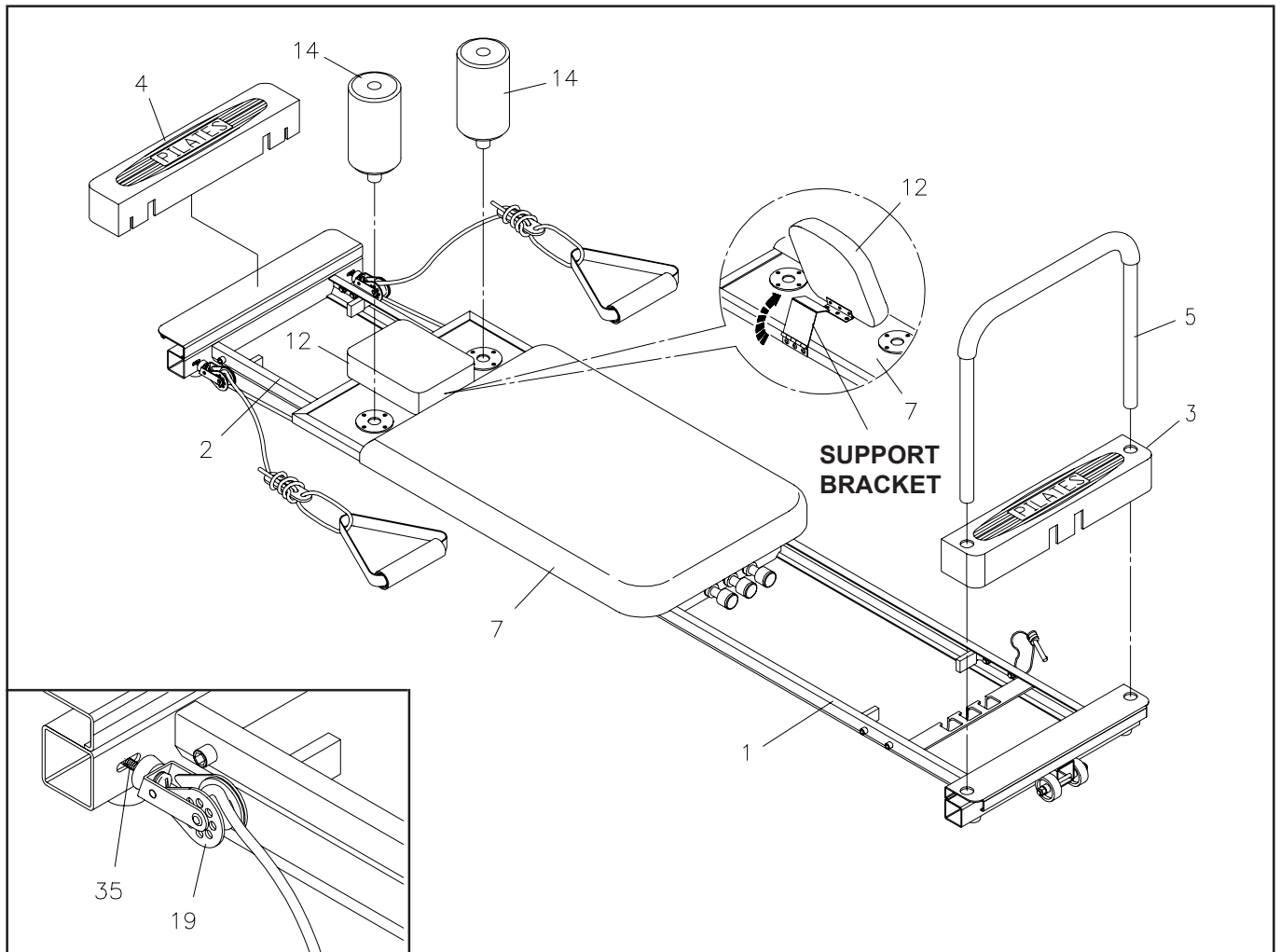

### STEP 4

Remove the paper covering from the foam tape inside the **FRONT COVER(3)** and **REAR COVER(4)**. Place the **FRONT COVER(3)** over the **FRONT FRAME(1)**. Place the **REAR COVER(4)** over the **REAR FRAME(2)**. Press the covers securely in place.

**NOTE:** The securing **SCREWS(M6 x 35mm)(35)** for the **PULLEY ASSEMBLY(19)** on each side may need to be loosened to allow the **REAR COVER(4)** to fit securely over the frame. Refer to the inset illustration. When retightening the screws for the **PULLEY ASSEMBLY(19)** do not over tighten. The **PULLEY ASSEMBLY(19)** should move freely.

### STEP 5

Insert the **FOOT REST(5)** into the mounting holes located on the **FRONT FRAME(1)**. The **FOOT REST(5)** should pass through the **FRONT COVER(3)** and the **FRONT FRAME(1)**.

### STEP 6

Insert the **FOAM PAD ASSEMBLIES(14)** into the holes located on the **CUSHION ASSEMBLY(7)**.

### STEP 7

The **HEAD REST(12)** on the **CUSHION ASSEMBLY(7)** can be positioned at an incline by simply pivoting the **SUPPORT BRACKET** underneath the **HEAD REST(12)**.

## ASSEMBLY INSTRUCTIONS

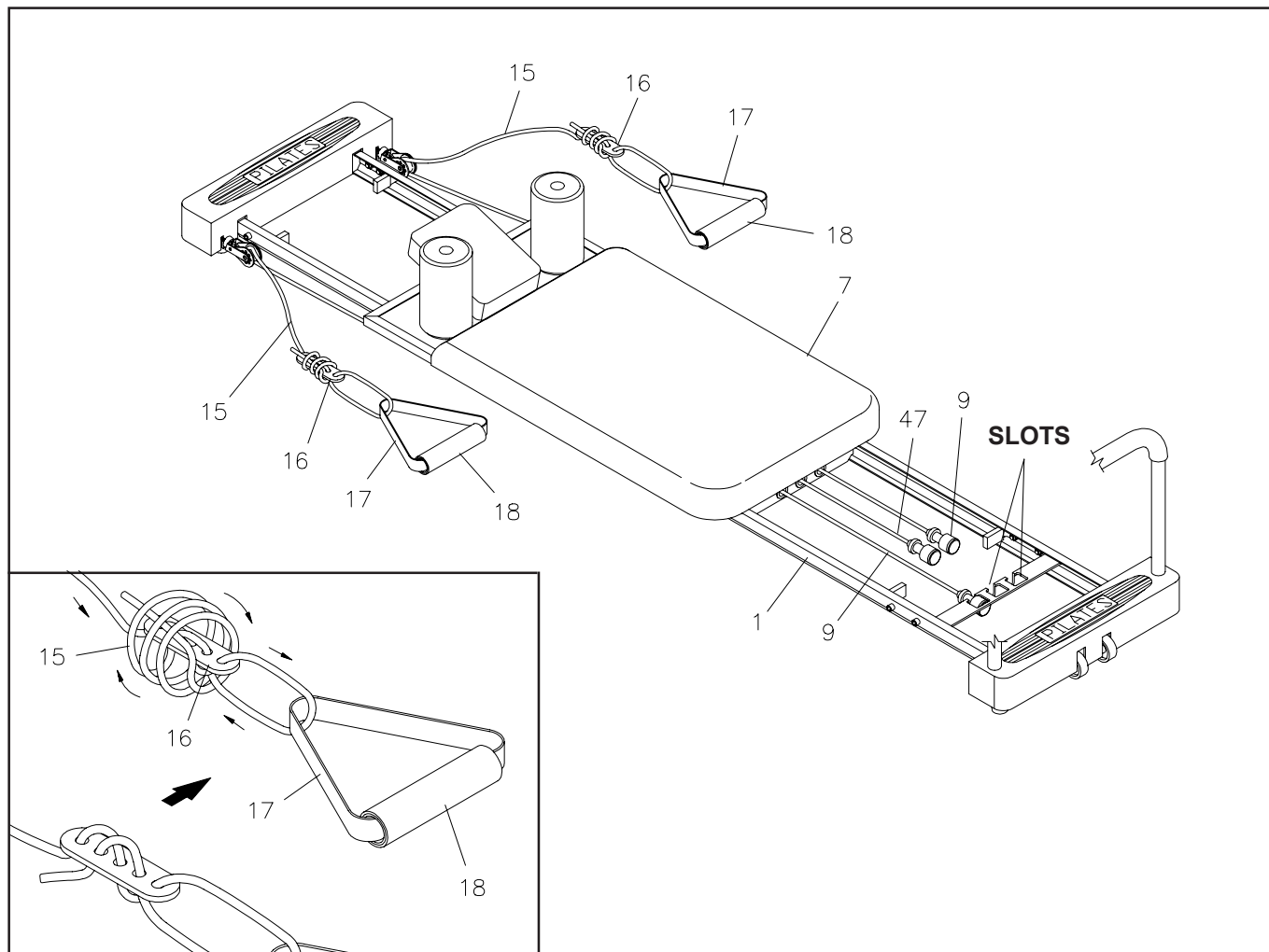

### STEP 8

There are two **TENSION CORD ASSEMBLIES(9)** and one heavier **RED POWER CORD ASSEMBLY(47)**. The resistance of the **CUSHION ASSEMBLY(7)** can be adjusted by securing the **TENSION CORD ASSEMBLIES(9, 47)** in the slots located on the **FRONT FRAME(1)**. You can achieve various levels of resistance by securing different numbers of the **TENSION CORD ASSEMBLIES(9, 47)** in the slots.

**NOTE:** To achieve greater resistance in the **RED POWER CORD** and **TENSION CORD ASSEMBLIES(47, 9)**, stretch and re-tie the tension cords in a more taut position.

### STEP 9

The length on the **ROPE(15)** can be adjusted by pulling the **ROPE(15)** through the **ROPE ADJUSTMENT BRACKET(16)** as shown. Be sure to adjust both ropes to the same length. In addition to the **ROPE(15)**, the **HAND STRAP(17)** can be adjusted to accommodate your size and workout needs. If you find you need to adjust the **ROPE(15)** even more, wrap the excess **ROPE(15)** around the **ROPE ADJUSTMENT BRACKET(16)**. Refer to the inset illustration.



---

## STORAGE

1. To store the **PILATES 4500 JP** simply keep it in a clean dry place.
2. Move the **PILATES 4500 JP** with the moving wheels on the **FRONT FRAME(1)**. Grasp on the back end of the **REAR FRAME(2)** to move the **PILATES 4500 JP**.

## MAINTENANCE

The safety and integrity designed into the **PILATES 4500 JP** can only be maintained when the **PILATES 4500 JP** is regularly examined for damage and wear. Special attention should be given to the following:

1. Inspect all the **TENSION CORD ASSEMBLIES(9, 47)** for cracks or tears before each use. Do not use damaged cords.
2. It is the sole responsibility of the user/owner to ensure that regular maintenance is performed.
3. Verify that all nuts and bolts are present and properly tightened. Replace missing nuts and bolts. Tighten loose nuts and bolts.
4. Worn or damaged components shall be replaced immediately or **PILATES 4500 JP** removed from service until repair is made.
5. Only Stamina Products supplied components shall be used to maintain/repair the **PILATES 4500 JP**.
6. Keep your **PILATES 4500 JP** clean by wiping with an absorbent cloth after use.

## CONDITIONING GUIDELINES

How you begin your exercise program depends on your physical condition. If you have been inactive for several years, or are severely overweight, you must start slowly and increase your time on the **PILATES 4500 JP** gradually: a few minutes per workout.

Initially, you may be able to exercise only for a few minutes in your target zone, however, your aerobic fitness will improve over the next six to eight weeks. Don't be discouraged if it takes longer. It's important to work at your own pace. Ultimately, you'll be able to exercise continuously for 30 minutes. The better your aerobic fitness, the harder you will have to work to stay in your target zone. Please remember these essentials:

- Have your doctor review your training and diet programs to advise you of a workout routine you should adopt.
- Begin your training program slowly with realistic goals that have been set by you and your doctor.
- Monitor your pulse frequently. Establish your target heart rate base on your age and condition.
- Set up your **PILATES 4500 JP** on a flat, even surface at least 3 feet from walls and furniture.

## EXERCISE INTENSITY

To maximize the benefits of exercising, it is important to exercise with the proper intensity. The proper intensity level can be found by using your heart rate as a guide. For effective aerobic exercise, your heart rate should be maintained at a level between 70% and 85% of your maximum heart rate as you exercise. This is known as your target zone. You can find your target zone in the table below. Target zones are listed for both unconditioned and conditioned persons according to age.

AGE	UNCONDITIONED TARGET ZONE (BEATS/MIN.)	CONDITIONED TARGET ZONE (BEATS/MIN.)
20	138~167	133~162
25	136~166	132~160
30	135~164	130~158
35	134~162	129~156
40	132~161	127~155
45	131~159	125~153
50	129~156	124~150
55	127~155	122~149
60	126~153	121~147
65	125~151	119~145
70	123~150	118~144
75	122~147	117~142
80	120~146	115~140
85	118~144	114~139

During the first few months of your exercise program, keep your heart rate near the low end of your target zone as you exercise. After a few months, your heart rate can be increased gradually until it is near the middle of your target zone as you exercise.

To measure your heart rate, stop exercising but continue moving your legs or walking around and place two fingers on your wrist. Take a six-second heartbeat count and multiply the results by 10 to find your heart rate. For example, if your six-second heartbeat count is 14, your heart rate is 140 beats per minute. (A six-second count is used because your heart rate will drop rapidly when you stop exercising.) Adjust the intensity of your exercise until your heart rate is at the proper level.

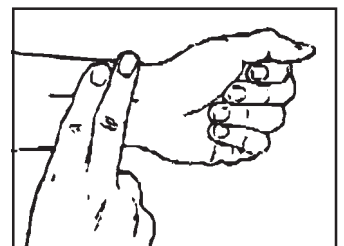

---

## WARM-UP and COOL-DOWN

**Warm-up** The purpose of warming up is to prepare your body for exercise and to minimize injuries. Warm up for two to five minutes before strength-training or aerobic exercising. Perform activities that raise your heart rate and warm the working muscles. Activities may include brisk walking, jogging, jumping jacks, jump rope, and running in place

**Stretching** Stretching while your muscles are warm after a proper warm-up and again after your strength or aerobic training session is very important. Muscles stretch more easily at these times because of their elevated temperature, which greatly reduces the risk of injury. Stretches should be held for 15 to 30 seconds. Do not bounce.

### Suggested Stretching Exercises

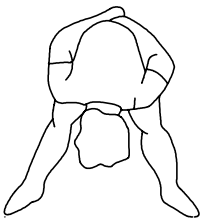

#### Lower Body Stretch

Place feet shoulder-width apart and lean forward. Keep this position for 30 seconds using the body as a natural weight to stretch the backs of the legs. **DO NOT BOUNCE!** When the pull on the back of the legs lessen, try a lower position gradually.

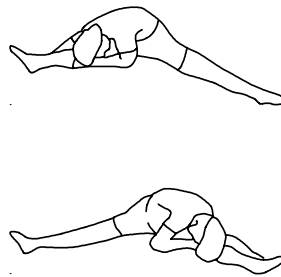

#### Floor Stretch

While sitting on the floor, open the legs as wide as possible. Stretch the upper body toward the knee on the right leg by using your arms to pull your chest to your thighs. Hold this stretch 10 to 30 seconds. **DO NOT BOUNCE!** Do this stretch 10 times. Repeat the stretch with the left leg.

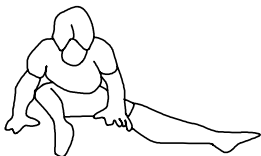

#### Bent Torso Pulls

While sitting on the floor, have legs apart one leg straight and one knee bent. Pull the chest down to touch the thigh on the leg that is bent and twist at the waist. Hold this position at least 10 seconds. Repeat 10 times on each side.

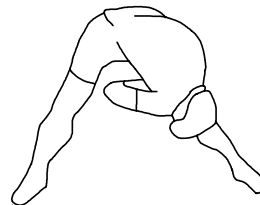
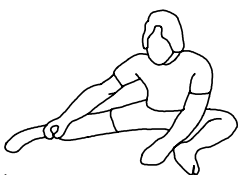

#### Bent Over Leg Stretch

Stand with feet shoulder-width apart and lean forward as illustrated. Using the arms, **gently** pull the upper body towards the right leg. Let the head hang down. **DO NOT BOUNCE!** Hold the position a minimum of 10 seconds. Repeat pulling the upper body to the left leg. Do this stretch several times slowly.

**Remember always to check with your physician before starting any exercise program.**

**Cool-Down** The purpose of cooling down is to return the body to its normal, or near normal, resting state at the end of each exercise session. A proper cool-down slowly lowers your heart rate and allows blood to return to the heart. Your cool-down should include the stretches listed above and should be completed after each strength-training session.

# PRODUCT PARTS DRAWING

BACK

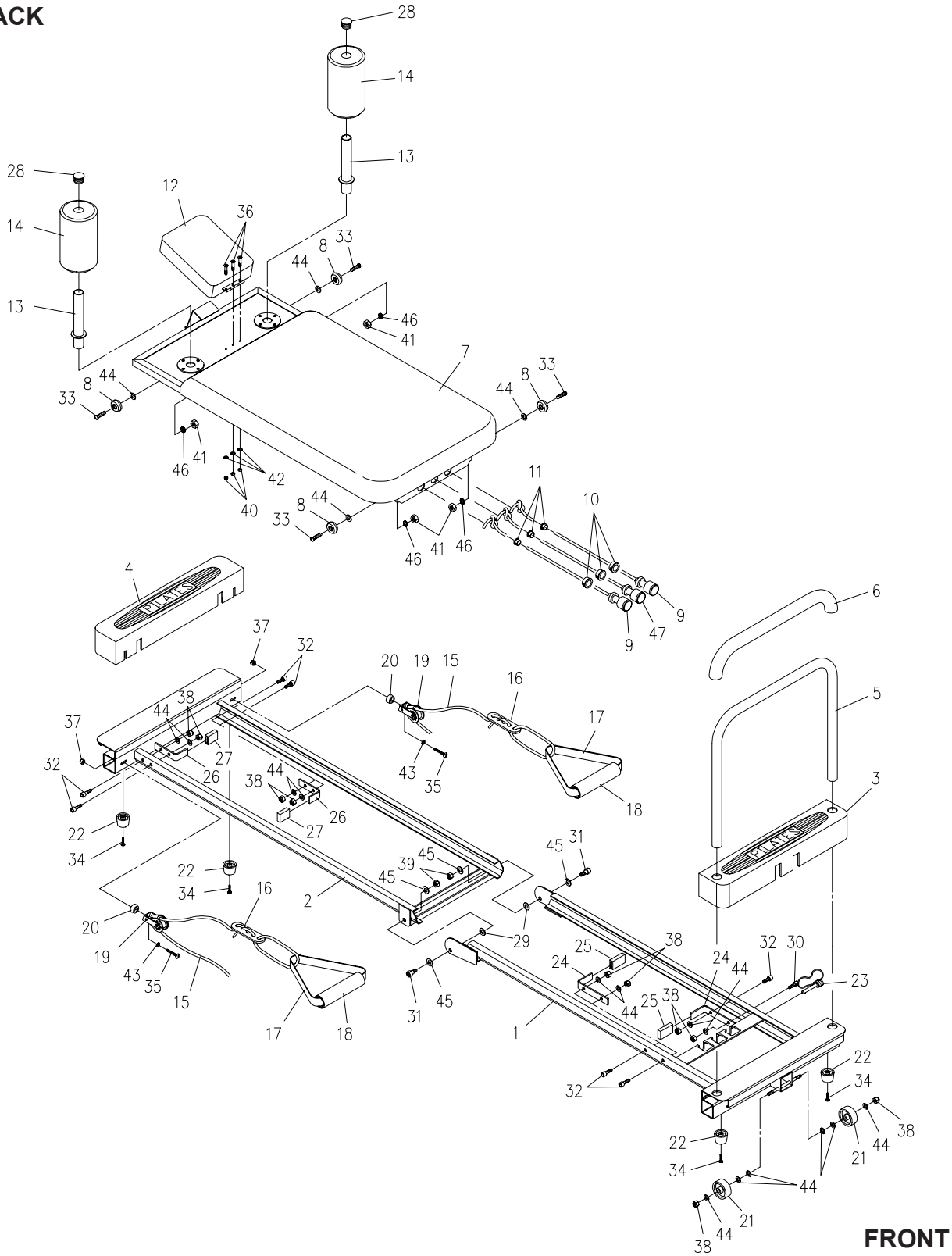

FRONT

---

## PARTS LIST

DIAGRAM#	PART NAME	QTY
1	Front Frame	1
2	Rear Frame	1
3	Front Cover	1
4	Rear Cover	1
5	Foot Rest	1
6	Foam Sleeve	1
7	Cushion Assembly	1
8	Cushion Assembly Roller	4
9	Tension Cord Assembly	2
10	Support Bushing	3
11	Stop Bushing	3
12	Head Rest	1
13	Foam Pad Tube	2
14	Foam Pad	2
15	Rope	2
16	Rope Adjustment Bracket	2
17	Hand Strap	2
18	Hand Grip	2
19	Pulley Assembly	2
20	Pulley Spacer	2
21	Plastic Wheel	2
22	Rubber Foot	4
23	Locking Pin	1
24	Stop Plate	2
25	Stop Pad	2
26	Small Stop Plate	2
27	Small Stop Pad	2
28	Round Plug (25mm)	2
29	Spacer (M10)	2
30	Bolt, Socket Head /w Hole (M8x1.25x20mm)	1
31	Bolt, Socket Head (M10 x 1.5 x 20mm)	2
32	Bolt, Socket Head (M8 x 1.25 x 20mm)	7
33	Bolt, Round Head (M8 x 1.25 x 25mm)	4
34	Screw, Round Head (M5 x 0.8 x 25mm)	4
35	Screw, Round Head (M6 x 1 x 35mm)	2
36	Screw, Flat Head (M5 x 0.8 x 25mm)	3
37	Nylon Nut (M6 x 1)	2
38	Nylon Nut (M8 x 1.25)	10
39	Nylon Nut (M10 x 1.5)	2
40	Nylon Nut (M5 x 0.8)	3
41	Nut (M8 x 1.25)	4
42	Washer (M5)	3
43	Washer (M6)	2
44	Washer (M8)	18
45	Washer (M10)	4
46	Lock Washer (M8)	4
47	Red Power Cord Assembly	1
48	Combination Wrench	1
49	Socket Wrench	1
50	Manual	1
51	Basic Workout Video	1
52	Intermediate Workout Video	1
53	Workout Chart	1

**WARRANTY**

Stamina Products, Inc. warrants that this product will be free from defects in materials and workmanship under normal use, service and proper operation for a period of 90 days on the parts and three years on the frame from the date of the original purchase from an authorized retailer. **THIS WARRANTY SHALL NOT APPLY TO ANY PRODUCT WHICH HAS BEEN SUBJECT TO COMMERCIAL USE, ABUSE, MISUSE, ALTERATION OF ANY TYPE OR CAUSE OR TO ANY DEFECT OR DAMAGE CAUSED BY REPAIR, REPLACEMENT, SUBSTITUTION OR USE WITH PARTS OTHER THAN PARTS PROVIDED BY STAMINA PRODUCTS, INC.** Commercial use includes use of the product in athletic clubs, health clubs, spas, gymnasiums, exercise facilities, and other public or semipublic facilities whether or not the product's use is in furtherance of a profit making enterprise, and all other use which is not for personal, family, or household purposes.

To implement this limited warranty, send a written notice stating your name, date, and place of purchase and a brief description of the defect along with your receipt to **Stamina Products, Inc. P.O. Box 1071, Springfield Missouri, USA, 65801-1071** or call us at **1 (800) 375-7520**. If the defect is covered under this limited warranty, you will be requested to return the product or part to us for free repair or replacement at our option. **NO ACTION FOR BREACH OF THIS LIMITED WARRANTY MAY BE COMMENCED MORE THAN ONE (1) YEAR AFTER THE DATE THE ALLEGED BREACH WAS OR SHOULD HAVE BEEN DISCOVERED. NO ACTION FOR BREACH OF ANY IMPLIED WARRANTY MAY BE COMMENCED MORE THAN ONE (1) YEAR AFTER DELIVERY OF THE PRODUCT TO THE PURCHASER.** This limited warranty is not transferable. **IF ANY PART OF THE PRODUCT IS NOT IN COMPLIANCE WITH THIS LIMITED WARRANTY OR ANY IMPLIED WARRANTY, THE REMEDY OF REPAIR OR REPLACEMENT IS THE EXCLUSIVE REMEDY AVAILABLE TO YOU.** In the event that the purchaser makes any claim under this limited warranty or any implied warranty, the Warrantor reserves the right to require the product to be returned for inspection, at the purchaser's expense, to the Warrantor's premises in Springfield, Missouri. Return of the enclosed warranty registration card is not required for warranty coverage, but is merely a way of establishing the date and place of purchase.

Stamina Products, Inc. **SHALL NOT BE LIABLE FOR THE LOSS OF USE OF ANY PRODUCT, LOSS OF TIME, INCONVENIENCE, COMMERCIAL LOSS OR ANY OTHER INDIRECT, CONSEQUENTIAL, SPECIAL OR INCIDENTAL DAMAGES DUE TO BREACH OF THE ABOVE WARRANTY OR ANY IMPLIED WARRANTY.**

This limited warranty is the only written or express warranty given by Stamina Products, Inc. This warranty gives you specific legal rights, and you may also have other legal rights which vary from state to state. **ANY OTHER RIGHT WHICH YOU MAY HAVE, INCLUDING ANY IMPLIED WARRANTY OR MERCHANTABILITY OR FITNESS FOR A PARTICULAR PURPOSE, IS LIMITED IN DURATION TO THE DURATION OF THIS WARRANTY.**

The laws in some jurisdictions restrict the rights of manufacturers and distributors of consumer goods to disclaim or limit implied warranties and consequential and incidental damages with respect thereto. If any such law is found to be applicable, the foregoing disclaimers and limitations of and on implied warranties and consequential and incidental damages with respect thereto shall be disregarded and shall be deemed not to have been made to the extent necessary to comply with such legal restriction.

