



1612 Hutton Drive, Suite 140 • Carrollton, Texas 75006
Phone: (800) 558-6960 • Fax: (972) 389-4752

KELLEY

■ HYDRAULICPLUS™ DOCKLEVELER STANDARDIZED PIT DETAILS

■ STAR® CONDUIT RUN DETAILS *(Back Cover)*

CUSTOMER _____

ADDRESS _____

JOB _____

DOCKLEVELER: HYDRAULIC MODEL NUMBER _____ QUANTITY _____

DOCKLEVELER RATING PER ANSI MH14.1-1987:

30K 35K 40K 45K 50K

LIP LENGTH: 16" 18" 20"

HYDRAULIC DOCKLEVELER ELECTRICAL REQUIREMENTS:

Voltage: 100 115 208 220 230 380 460 575
Phase: 1Ø 3Ø
Frequency: 60 Hz 50 Hz
Solar

STAR RESTRAINTS: STAR 1 STAR 1 with TRUK ALERT STAR 4
 STAR 2

NOTE: All STAR restraints, except STAR 1, require 115V, 1Ø, 60 Hz.

CERTIFIED FOR CONSTRUCTION

BY _____ DATE _____

COMPANY _____

CITY & STATE _____

▲ WARNING

Death or serious injury could result from failure to follow Kelley specifications for pit dimensions and/or configurations, or conduit location; improper installation of dock leveler, anchoring devices or optional/accessory equipment; installation into improperly formulated, prepared or placed concrete or concrete which is otherwise inadequate or unsound

HYDRAULICPLUS™ DOCKLEVELER STANDARDIZED PIT DETAILS

Hydraulic Dockleveler Control	Voltage (V) and Phase (Ø)	Quantity and Wire Gauge (GA)		Total Quantity of Wires
		12 GA	14 GA	
Standard Control Box	115V, 1Ø	3		3
	230V, 1Ø		3	3
	190V-545V, 3Ø		4	4
Optional Control Box Auto-Return to Dock	115V, 1Ø	3	2	5
	230V, 1Ø		5	5
	190V-545V, 3Ø		6	6

FOR SOLAR APPLICATIONS SEE APPROVAL DRAWINGS FOR ALL CONDUIT AND WIRE INFORMATION

FOR TYPE AND QUANTITY OF PROPER REAR PIT WALL MOUNTED RECEPTACLE(S) AND WIRING DIAGRAMS, SEE KELLEY PRODUCT MANUAL

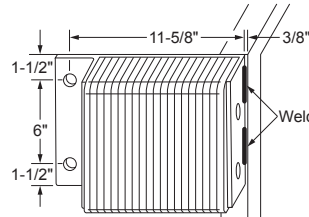
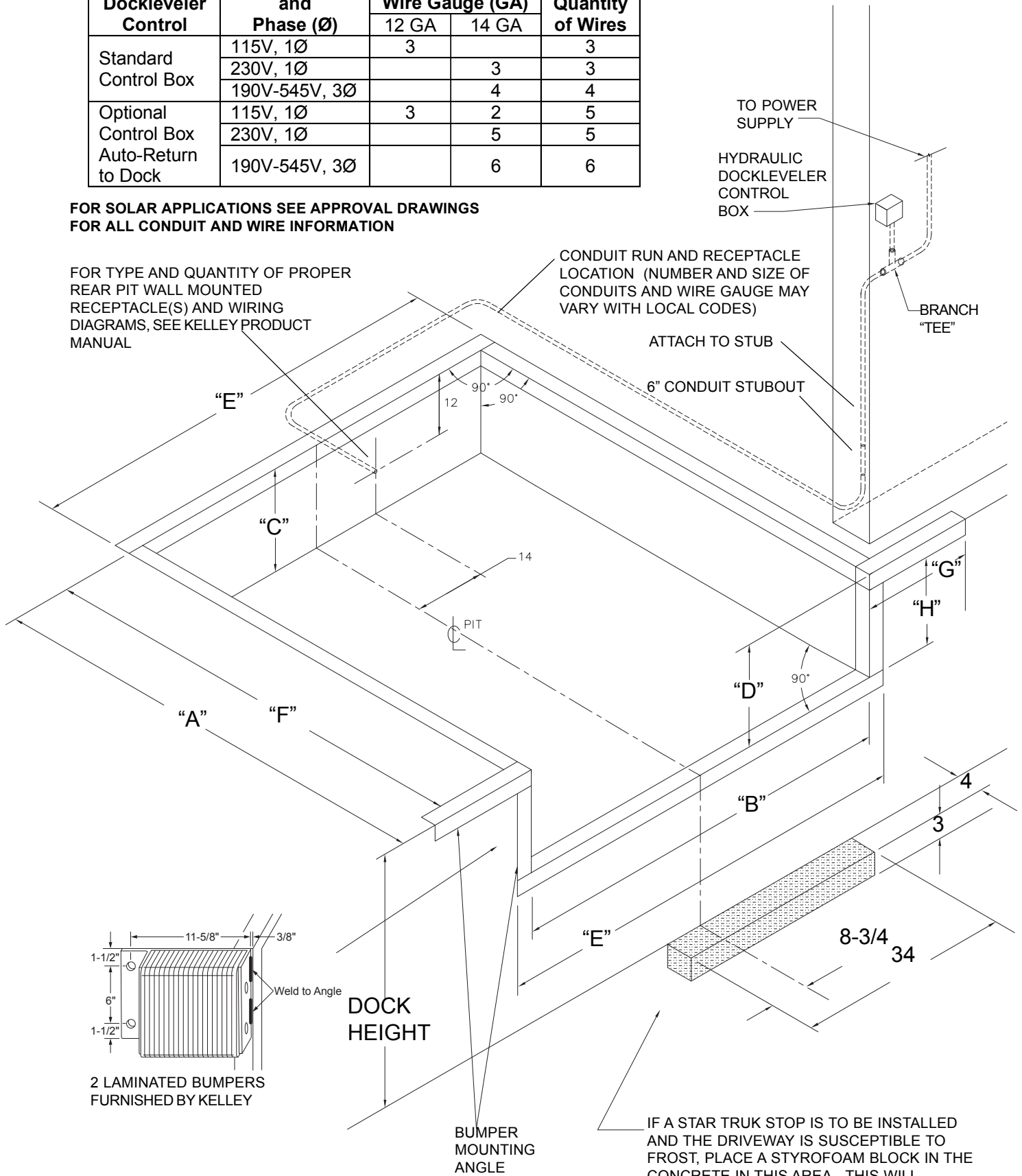

DOCK HEIGHT

BUMPER MOUNTING ANGLE

IF A STAR TRUK STOP IS TO BE INSTALLED AND THE DRIVEWAY IS SUSCEPTIBLE TO FROST, PLACE A STYROFOAM BLOCK IN THE CONCRETE IN THIS AREA. THIS WILL PREVENT DAMAGE TO THE STAR TRUK STOP WHEN DRIVEWAY RISES.

LOCATION FOR HYDRAULIC DOCKLEVELER AND STAR CONTROLS

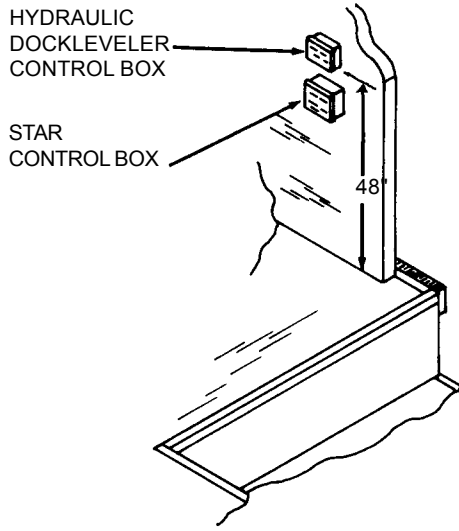

LOCATION FOR SINGLE CONTROL BOX FOR DOCKLEVELER OR STAR

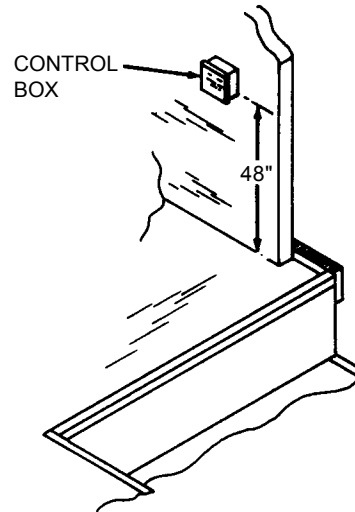

ANCHOR LAYOUT FOR CURB ANGLE

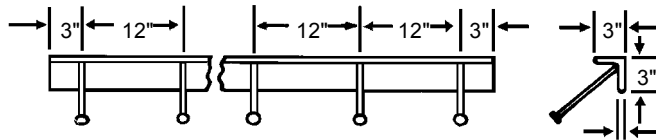

CONCRETE ANCHORS, 1/2" DIA., 6" LONG, LOCATED AS SHOWN

NOMINAL DOCKLEVELER SIZE		6' x 6'	6' x 8'	6' x 10'	6.5' x 6'	6.5' x 8'	6.5' x 10'	7' x 6'	7' x 8'	7' x 10'
PIT LENGTH	DIM. "A"	63"	87"	111"	63"	87"	111"	63"	87"	111"
PIT WIDTH	DIM. "B"	74"	74"	74"	80"	80"	80"	85"	85"	85"
PIT DEPTH Rear	DIM. "C"	19-1/2"	19-1/2"	23-1/2"	19-1/2"	19-1/2"	23-1/2"	19-1/2"	19-1/2"	23-1/2"
PIT DEPTH Front	DIM. "D"	20"	20"	24"	20"	20"	24"	20"	20"	24"
CURB ANGLE Front & Rear	DIM. "E"	80"	80"	80"	86"	86"	86"	91"	91"	91"
CURB ANGLE Side	DIM. "F"	60"	84"	108"	60"	84"	108"	60"	84"	108"
CURB ANGLE Bumper	DIM. "G"	21"	21"	21"	21"	21"	21"	21"	21"	21"
CURB ANGLE Bumper	DIM. "H"	17"	17"	21"	17"	17"	21"	17"	17"	21"

- NOTES: 1) See Kelley Product Manual for Powered Dockleveler Wiring Diagrams and Typical Installation Drawings.
 2) See Kelley Drawing No. 10-740 for Cantilever Pit Detail.

STAR® CONDUIT RUN LOCATION DETAILS

NOTE: ALL MOTOR POWER WIRES OR OTHER HIGH VOLTAGE WIRES SHOULD BE RUN IN A SEPARATE CONDUIT FROM ALL LOW VOLTAGE CONTROL CIRCUIT WIRING.

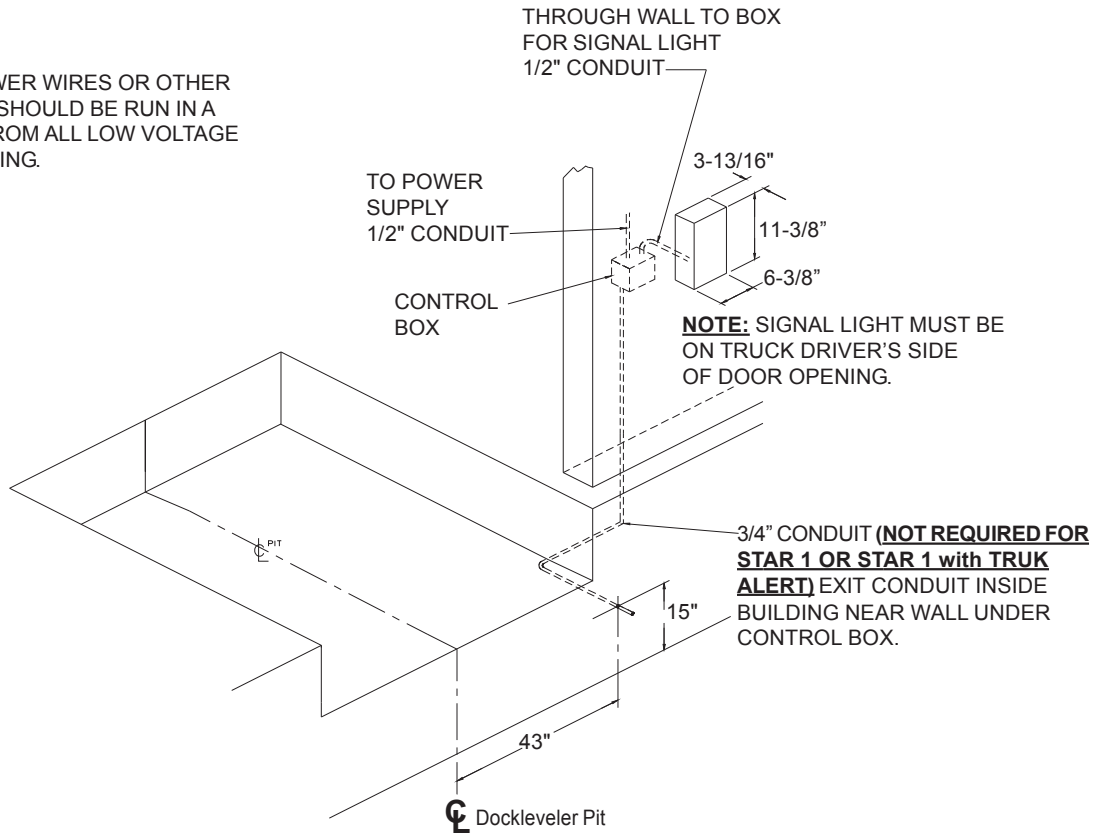

*ADDITIONAL CONDUIT REQUIREMENTS FOR OPTIONAL FLOOD PACKAGE — STAR 4

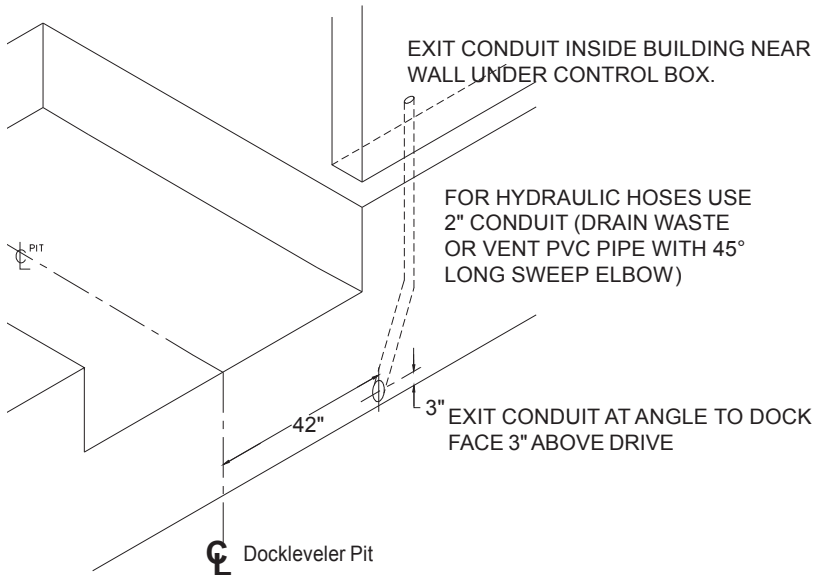

*ADDITIONAL CONDUIT REQUIREMENTS FOR OPTIONAL LIP LIMIT SWITCH — STAR 4

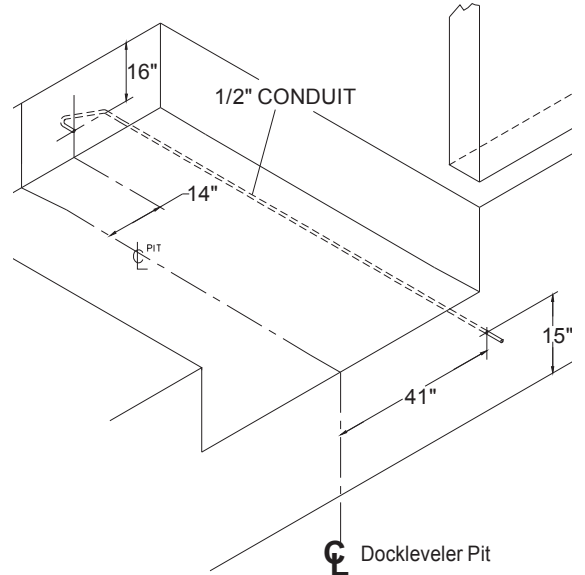

***Requires both the standard conduit run and the additional conduit for the option.**



1612 Hutton Drive, Suite 140 • Carrollton, Texas 75006
Phone: (800) 558-6960 • Fax: (972) 389-4752