

NordicTrack[®] **EX 3300**

Model No. NETL81906.0

Serial No. _____

Write the serial number in the space above for future reference.

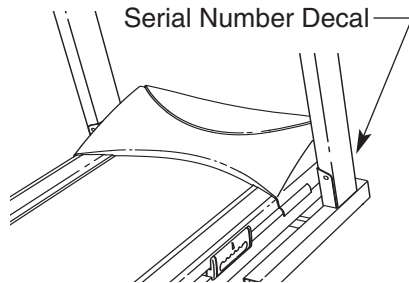

USER'S MANUAL

QUESTIONS?

As a manufacturer, we are committed to providing complete customer satisfaction. If you have questions, or if there are missing or damaged parts, please call:

08457 089 009

or write:

ICON Health & Fitness, Ltd.
Customer Service Department
Unit 4
Revie Road Industrial Estate
Revie Road
Beeston
Leeds, LS118JG
UK

email: csuk@iconeurope.com

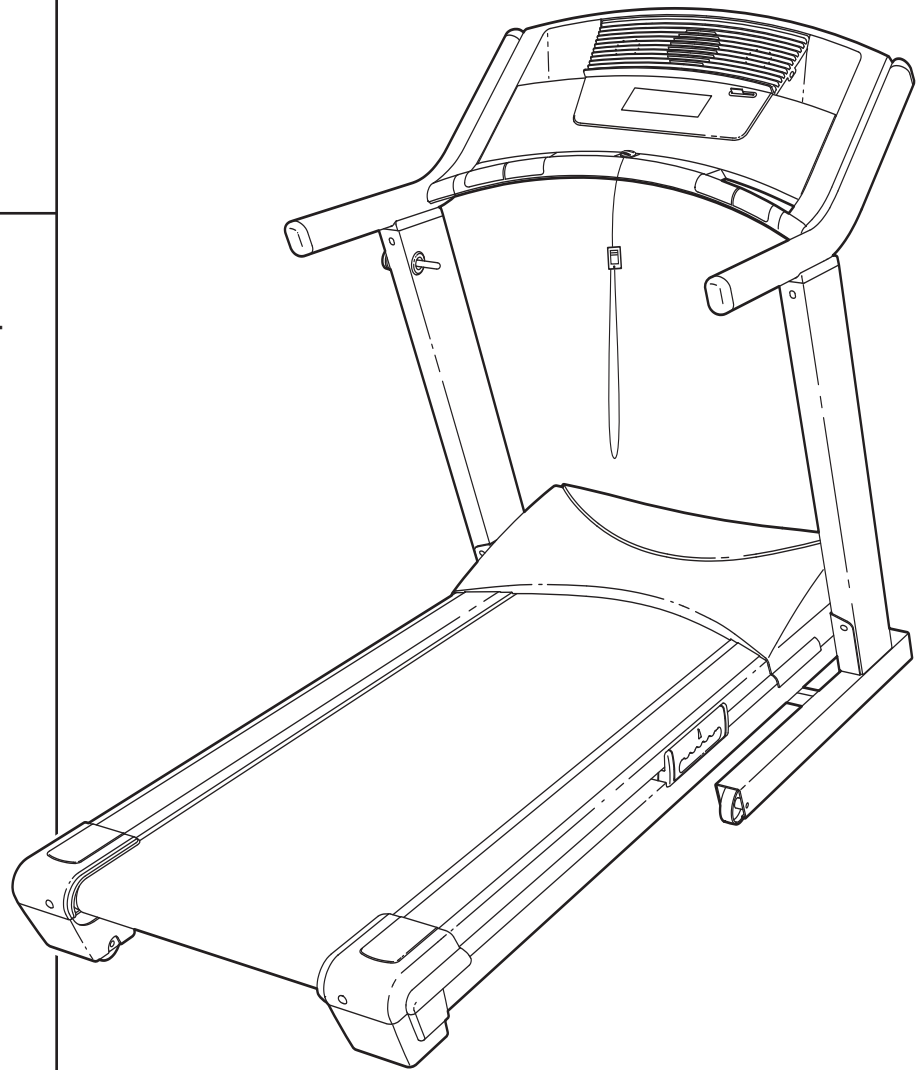

CAUTION

Read all precautions and instructions in this manual before using this equipment. Save this manual for future reference.



Visit our website at

www.iconeurope.com



NordicTrack[®] EX 3300

TABLE OF CONTENTS

IMPORTANT PRECAUTIONS	3
BEFORE YOU BEGIN	5
ASSEMBLY	6
OPERATION AND ADJUSTMENT	11
HOW TO FOLD AND MOVE THE TREADMILL	24
TROUBLESHOOTING	26
EXERCISE GUIDELINES	29
PART LIST	30
ORDERING REPLACEMENT PARTS	Back Cover

Note: An EXPLODED DRAWING is attached in the center of this manual.

IMPORTANT PRECAUTIONS

⚠ WARNING: To reduce the risk of burns, fire, electric shock, or injury to persons, read the following important precautions and information before operating the treadmill.

1. It is the responsibility of the owner to ensure that all users of this treadmill are adequately informed of all warnings and precautions.
2. Use the treadmill only as described.
3. Place the treadmill on a level surface, with at least 2.5 m (8 ft) of clearance behind it and 0.5 m (2 ft) on each side. Do not place the treadmill on a surface that blocks any air openings. To protect the floor or carpet from damage, place a mat under the treadmill.
4. Keep the treadmill indoors, away from moisture and dust. Do not put the treadmill in a garage or covered patio, or near water.
5. Do not operate the treadmill where aerosol products are used or where oxygen is being administered.
6. Keep children under the age of 12 and pets away from the treadmill at all times.
7. The treadmill should not be used by persons weighing more than 158 kg (350 lbs).
8. Never allow more than one person on the treadmill at a time.
9. Wear appropriate exercise clothes when using the treadmill. Do not wear loose clothes that could become caught in the treadmill. Athletic support clothes are recommended for both men and women. *Always wear athletic shoes. Never use the treadmill with bare feet, wearing only stockings, or in sandals.*
10. When connecting the power cord (see page 11), plug the power cord into an earthed circuit. No other appliance should be on the same circuit. When replacing the fuse, an ASTA approved BS1362 type should be fitted to the fuse carrier. A 13 amp fuse should be used.
11. Keep the power cord away from heated surfaces.
12. Never move the walking belt while the power is turned off. Do not operate the treadmill if the power cord or plug is damaged, or if the treadmill is not working properly. (See **BEFORE YOU BEGIN** on page 5 if the treadmill is not working properly.)
13. Read, understand, and test the emergency stop procedure before using the treadmill (see **HOW TO TURN ON THE POWER** on page 13).
14. Never start the treadmill while you are standing on the walking belt. Always hold the handrails while using the treadmill.
15. The treadmill is capable of high speeds. Adjust the speed in small increments to avoid sudden jumps in speed.
16. The pulse sensors are not medical devices. Various factors, including the user's movement, may affect the accuracy of heart rate readings. The pulse sensors are intended only as exercise aids in determining heart rate trends in general.
17. Never leave the treadmill unattended while it is running. Always remove the key, unplug the power cord and move the on/off switch to the off position when the treadmill is not in use. (See the drawing on page 5 for the location of the on/off switch.)
18. Do not attempt to raise, lower, or move the treadmill until it is properly assembled. (See **ASSEMBLY** on page 6, and **HOW TO FOLD AND MOVE THE TREADMILL** on page 24.) You must be able to safely lift 20 kg (45 lbs) in order to raise, lower, or move the treadmill.
19. Do not change the incline of the treadmill by placing objects under the treadmill.
20. When folding or moving the treadmill, make sure that the storage latch is fully closed.

21. When using iFIT cards, an electronic “chirp- ing” sound will alert you when the speed and/or incline of the treadmill is about to change. Always listen for the “chirp” and be prepared for speed and/or incline changes. In some instances, the speed and/or incline may change before the personal trainer describes the change.

22. When using iFIT cards, you can manually override the speed and incline settings at any time by pressing the speed and incline buttons. However, when the next “chirp” is heard, the speed and/or incline will change to the next settings of the program.

23. Always remove iFIT cards from the iFIT slot when you are not using them.

24. Inspect and properly tighten all parts of the treadmill every three months.

⚠ WARNING: Before beginning this or any exercise program, consult your physician. This is especially important for persons over the age of 35 or persons with pre-existing health problems. Read all instructions before using. ICON assumes no responsibility for personal injury or property damage sustained by or through the use of this product.

25. Never drop or insert any object into any opening on the treadmill.

26. **DANGER:** Always unplug the power cord immediately after use, before cleaning the treadmill, and before performing the maintenance and adjustment procedures described in this manual. Never remove the motor hood unless instructed to do so by an authorized service representative. Servicing other than the procedures in this manual should be performed by an authorized service representative only.

27. The treadmill is intended for in-home use only. Do not use the treadmill in any commercial, rental, or institutional setting.

SAVE THESE INSTRUCTIONS

⚠ WARNING:
Protect yourself and others from risk of serious injury. Read the user's manual and :

-  •Stand only on the side rails when starting or stopping treadmill.
- Change speed in small increments.
- Hold handrails to prevent falling, and always wear the safety clip while operating treadmill.
- Stop if you feel faint, dizzy, or short of breath.
- Fully engage storage latch before treadmill is moved or stored.
- Reduce incline to its lowest level before folding treadmill into storage position.

 •Never allow children on or around treadmill.

•Remove key when not in use.

 •Keep clothing, fingers, and hair away from moving belt.

•Never try to adjust or fix the belt while it is moving.

•Always wear athletic shoes while operating treadmill.

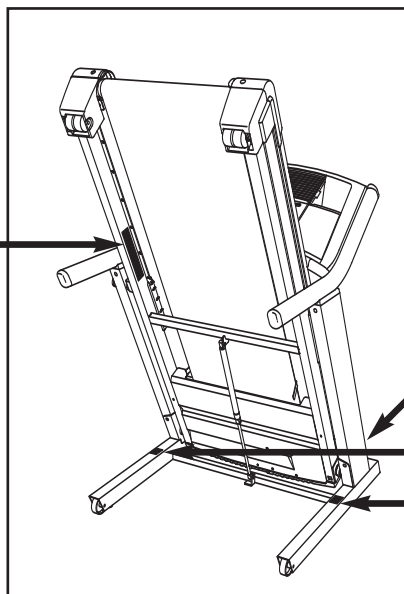

The decals shown have been placed on your treadmill. If a decal is missing, or if it is not legible, please call our Customer Service Department to order a free replacement decal (see the back cover of this manual). Apply the decal in the location shown.

⚠ CAUTION
KEEP HANDS AND FEET AWAY FROM THIS AREA WHILE THE TREADMILL IS IN OPERATION.

BEFORE YOU BEGIN

Thank you for selecting the revolutionary NordicTrack® EX 3300 treadmill. The EX 3300 treadmill offers an impressive selection of features designed to make your workouts at home more enjoyable and effective. And when you're not exercising, the unique EX 3300 treadmill can be folded up, requiring less than half the floor space of other treadmills.

For your benefit, read this manual carefully before using the treadmill. If you have additional questions,

see the front cover of this manual. To help us assist you, please note the product model number and serial number before calling. The model number of the treadmill is NETL81906.0. The serial number can be found on a decal attached to the treadmill (see the front cover of this manual for the location).

Before reading further, please familiarize yourself with the parts that are labeled in the drawing below.

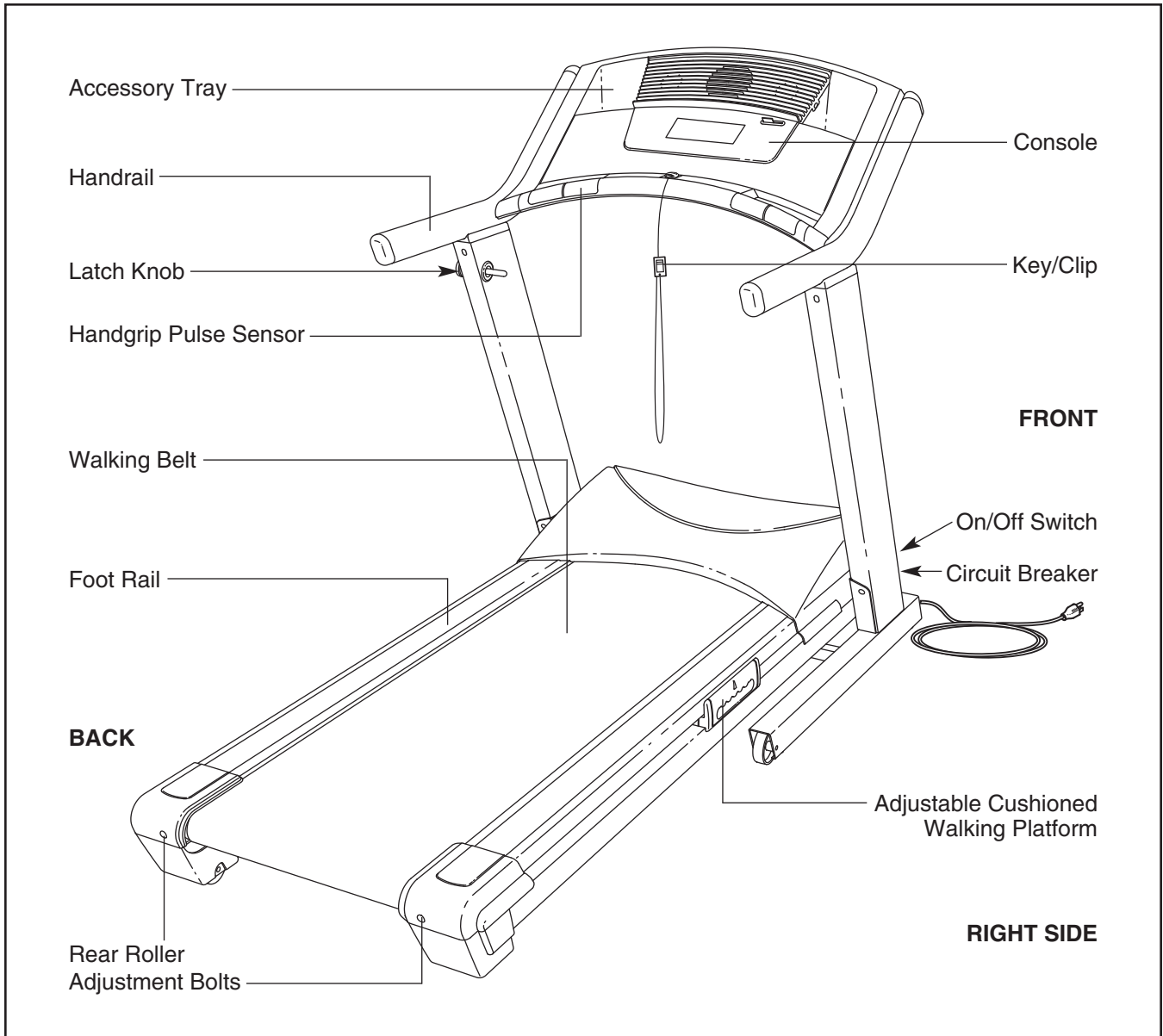

ASSEMBLY

Assembly requires two persons. Set the treadmill in a cleared area and remove all packing materials. Do not dispose of the packing materials until assembly is completed. Note: The underside of the treadmill walking belt is coated with high-performance lubricant. During shipping, a small amount of lubricant may be transferred to the top of the walking belt or the shipping carton. This is a normal condition and does not affect treadmill performance. If there is lubricant on top of the walking belt, simply wipe off the lubricant with a soft cloth and a mild, non-abrasive cleaner.

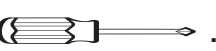
Assembly requires the included hex key  and your own phillips screwdriver .

For help identifying assembly hardware, see the drawings below. **Note: If a part is not found in the part bags, check to see if the part has been preattached. To avoid damaging plastic parts, do not use power tools for assembly.**

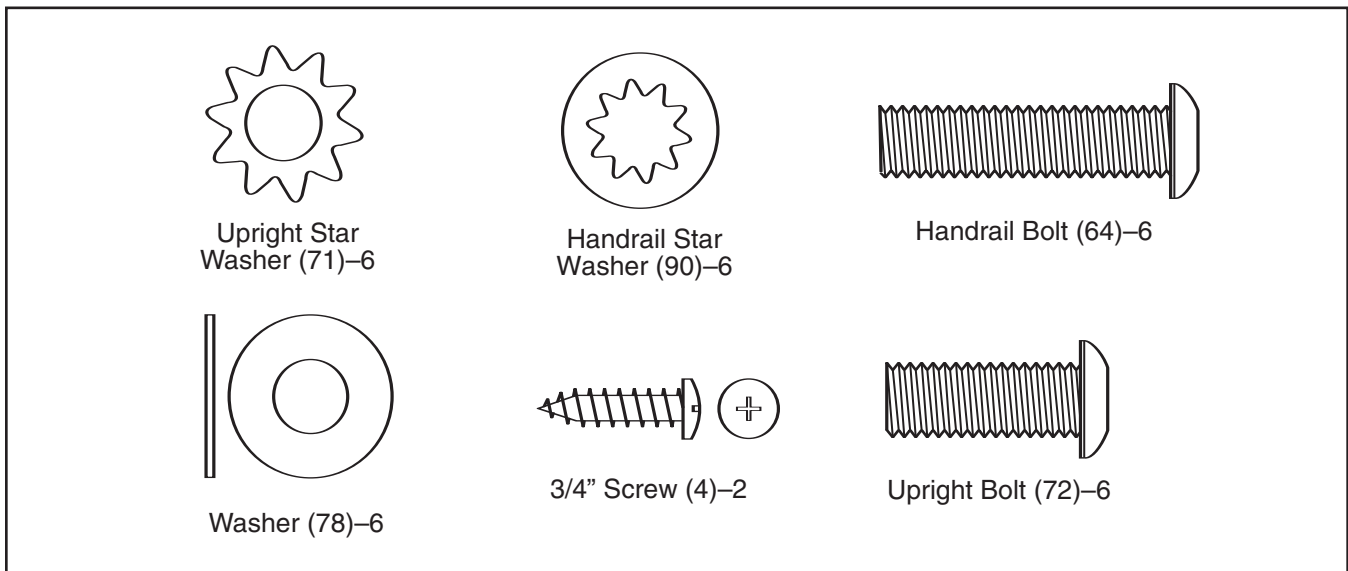

1. Identify the Left and Right Uprights (73, 74). The Left Upright has two large holes in the indicated locations.

Set the Right Upright (74) near the Frame (48) as shown. Insert the Upright Wire (75) into the lower end of the Right Upright and out of the top.

Place an elastic band around the Upright Wire (75) and the Right Upright (74) to keep the Upright Wire Harness from falling into the Right Upright. Leave the elastic band on until step 6.

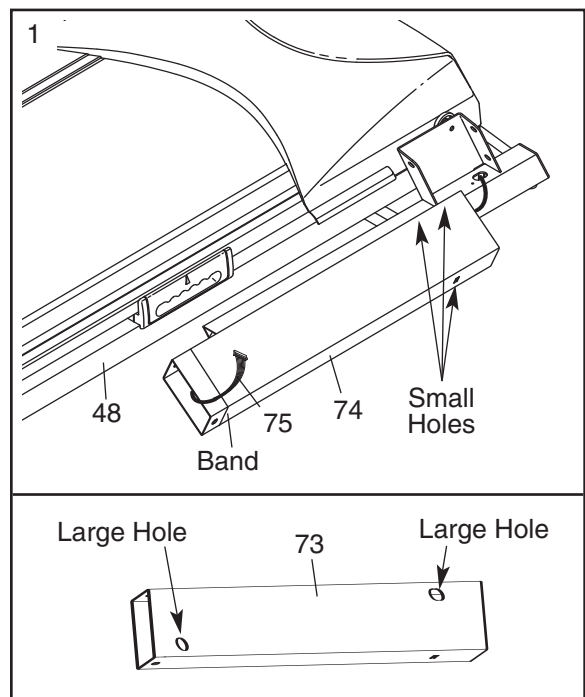

2. Insert the Right Upright (74) into the indicated bracket on the Base (83); **be careful not to dislodge the Cage Nuts (76) from the Right Upright (see the inset drawing). In addition, be careful not to pinch the Upright Wire Harness (75).** Finger tighten three Upright Bolts (72) with three Washers (78) and three Upright Star Washers (71) into the Right Upright and the bracket. **Do not tighten the Upright Bolts yet.**

Repeat this step with the Left Upright (not shown). Note: There is not a wire on the left side.

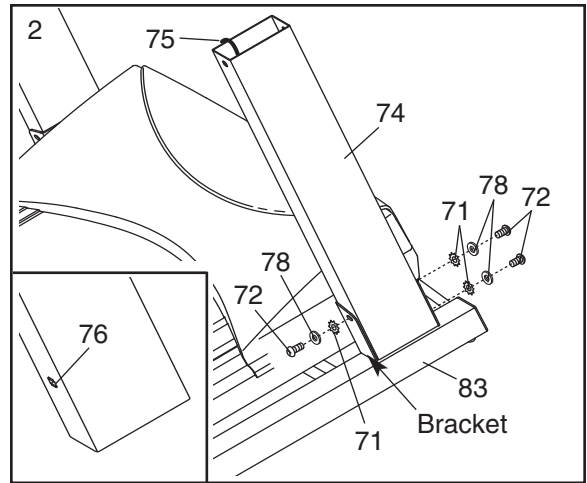

3. Attach the Catch (5) to the left side of the Frame (48) with two 3/4" Screws (4).

With the help of a second person, raise the Frame (48) to a vertical position. **Be careful not to raise the Frame past the vertical position. Have the other person hold the Frame until step 5 is completed.**

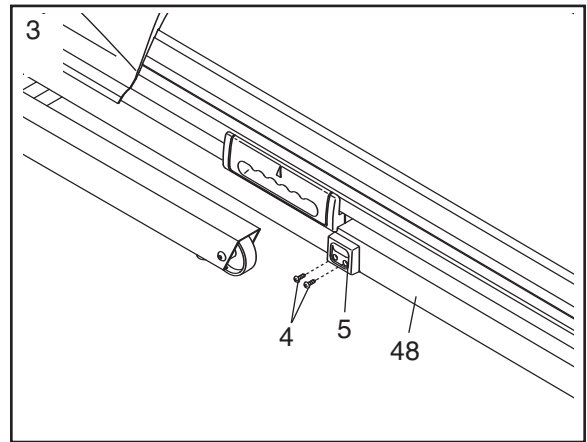

4. Hold the cylinder end of the Gas Spring (88) near the bracket in the center of the Frame (48).

See the two small inset drawings. Using your fingernail or the end of a screwdriver, press on the end of the Spring Pin (102) to loosen it from the Gas Spring (88). Next, rotate the Spring Pin and pull it out of the Shock. **Be careful to avoid losing the Spring Pin.**

Orient the Gas Spring (88) so it is in the position shown. Press the end of the Gas Spring onto the ball on the bracket.

See drawing 4a. Insert the Spring Pin (102) into the two indicated small holes in the end of the Gas Spring (88). Then, rotate the Spring Pin until it clips onto the Shock. Note: Extra Spring Pins are included.

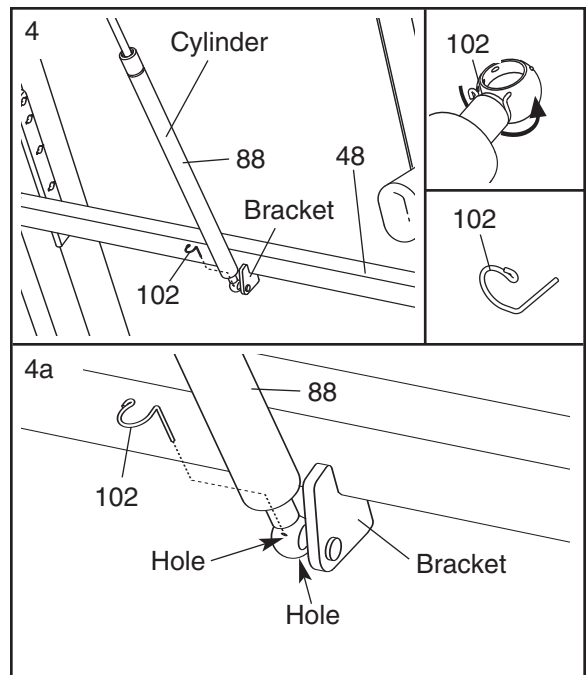

- Remove the Spring Pin (102) from the lower end of the Gas Spring (88).

Next, press the lower end of the Gas Spring (88) onto the ball on the bracket on the Base (83). If necessary, pivot the Frame (48) slightly and rotate the Gas Spring to align the end of the Gas Spring with the ball on the bracket.

See drawing 5a. Insert the end of the Spring Pin (102) into two of the small holes in the end of the Gas Spring (88). Then, rotate the Spring Pin until it clips onto the Gas Spring.

Carefully lower the Frame (48) to the floor.

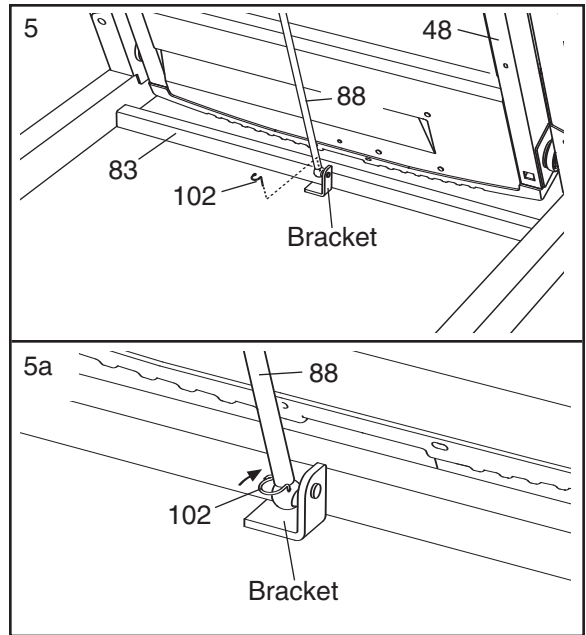

- Remove the elastic band holding the Upright Wire (75). Insert the Upright Wire through a Handrail Spacer (95). Press the Handrail Spacer into the top of the Right Upright (74). Press a Handrail Spacer into the Left Upright (73).

Have two people hold the console assembly near the Left Upright (73) and the Right Upright (74). Connect the Upright Wire (75) to the console wire. **Make sure to connect the connectors properly (see the inset drawing); the connectors should slide together easily and snap into place.** If the connectors do not slide together easily and snap into place, turn one connector and try again to connect them. **IF THE CONNECTORS ARE NOT CONNECTED PROPERLY, THE CONSOLE MAY BE DAMAGED WHEN THE POWER IS TURNED ON.**

Insert the Upright Wire (75) and the console wire into the Right Upright (74). Next, insert the brackets on the console assembly into the Right Upright and the Left Upright (73). **Be careful not to pinch the wires.**

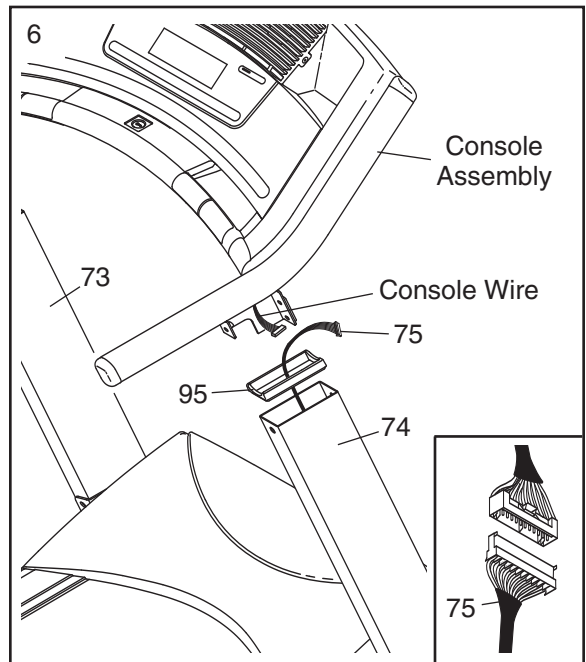

- Finger tighten three Handrail Bolts (64), with three Handrail Star Washers (90), into the Right Upright (74) and console assembly. Repeat with the Left Upright (73). **After all six Handrail Bolts have been started, tighten the four front Handrail Bolts before tightening the other two Bolts.**

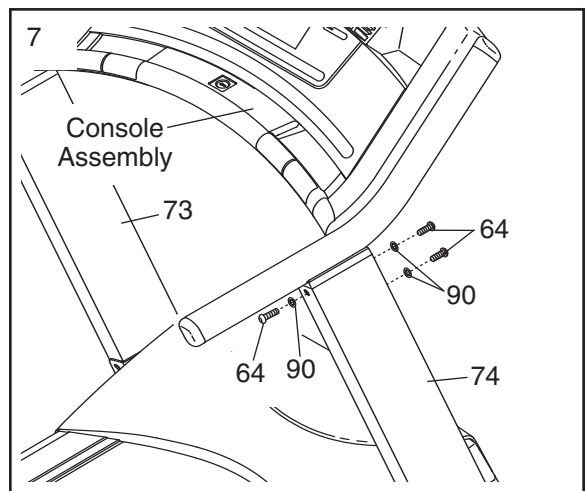

8. Press the Latch Sleeve (96) into the Left Upright (73). If necessary, use a rubber mallet to fully insert the Sleeve.

Remove the knob from the pin. **Make sure that the collar and the spring are on the pin.** Next, insert the pin into the Latch Sleeve (96) and the Left Upright (73), and tighten the knob back onto the pin.

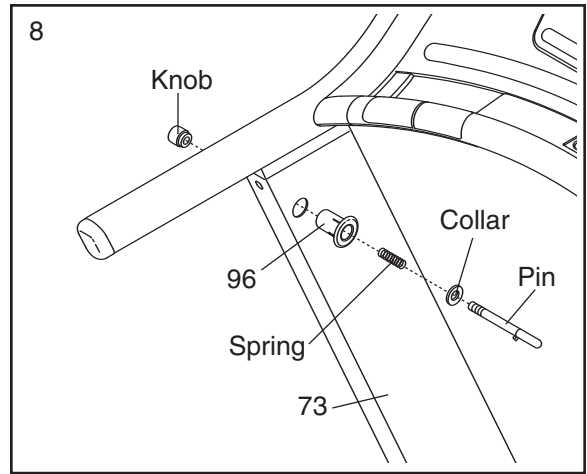

9. Place the treadmill in the storage position (see HOW TO FOLD THE TREADMILL FOR STORAGE on page 24). Center the Frame (48) between the Uprights (73, 74). **Tighten the Upright Bolts (72) in the lower ends of the Uprights (73, 74).**

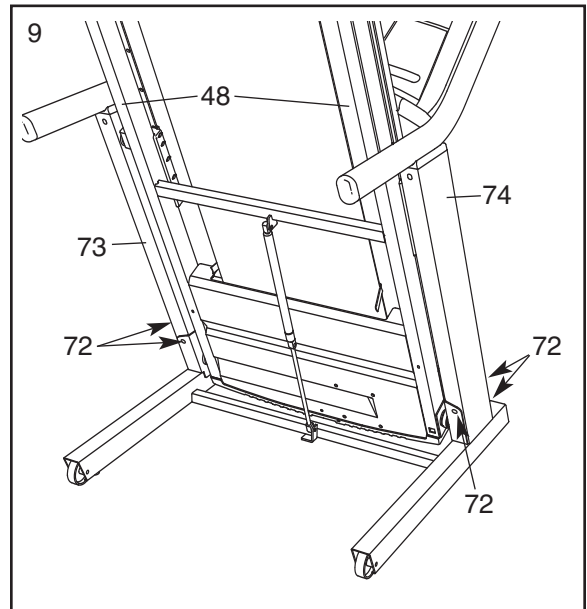

10. **Make sure that all parts are properly tightened before you use the treadmill.** Note: Extra hardware may be included. Keep the included hex key in a secure place; the hex key is used to adjust the walking belt (see page 27). To protect the floor or carpet, place a mat under the treadmill.

HOW TO USE THE CHEST PULSE SENSOR

HOW TO PUT ON THE CHEST PULSE SENSOR

The chest pulse sensor consists of two components: the chest strap and the sensor unit (see the drawing below). Insert the tab on one end of the chest strap into one end of the sensor unit, as shown in the inset drawing. Press the end of the sensor unit under the buckle on the chest strap. The tab should be flush with the front of the sensor unit.

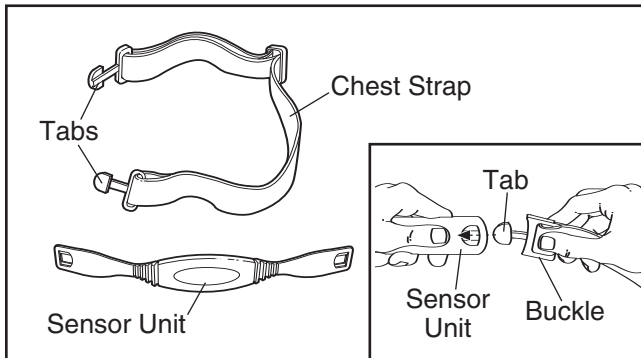

Next, wrap the chest pulse sensor around your chest, and attach the other end of the chest strap to the sensor unit. Adjust the length of the chest strap, if necessary. The chest pulse sensor

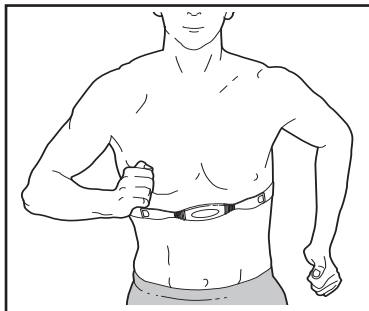

should be under your clothes, tight against your skin, and as high under the pectoral muscles or breasts as is comfortable. Make sure that the logo on the sensor unit is facing forward and is right-side-up.

Pull the sensor unit away from your body a few inches and locate the two electrode areas on the inner side (the electrode areas are covered by shallow ridges). Using saline solution such as saliva or contact lens solution, wet both electrode areas. Return the sensor unit to a position against your chest.

CHEST PULSE SENSOR CARE AND MAINTENANCE

- Thoroughly dry the chest pulse sensor after each use. The chest pulse sensor is activated when the electrode areas are wetted and the heart rate monitor is put on; the chest pulse sensor shuts off when it is removed and the electrode areas are dried. If the chest pulse sensor is not dried after

each use, it may remain activated longer than necessary, draining the battery prematurely.

- Store the chest pulse sensor in a warm, dry place. Do not store the chest pulse sensor in a plastic bag or other container that may trap moisture.
- Do not expose the chest pulse sensor to direct sunlight for extended periods of time; do not expose it to temperatures above 50° C (122° F) or below -10° C (14° F).
- Do not excessively bend or stretch the sensor unit when using or storing the chest pulse sensor.
- Clean the sensor unit using a damp cloth—never use alcohol, abrasives, or chemicals. The chest strap may be hand washed and air dried.

CHEST PULSE SENSOR TROUBLESHOOTING

The instructions on the following pages explain how the chest pulse sensor is used with the console. If the chest pulse sensor does not function properly, try the steps below.

- Make sure that you are wearing the chest pulse sensor as described at the left. Note: If the chest pulse sensor does not function when positioned as described, move it slightly lower or higher on your chest.
- Use saline solution such as saliva or contact lens solution to wet the two electrode areas on the sensor unit. If heart rate readings do not appear until you begin perspiring, re-wet the electrode areas.
- As you walk or run on the treadmill, position yourself near the center of the walking belt. **For the console to display heart rate readings, the user must be within arm's length of the console.**
- The chest pulse sensor is designed to work for people who have normal heart rhythms. Heart rate reading problems may be caused by medical conditions such as premature ventricular contractions (pvc's), tachycardia bursts, and arrhythmia.
- The operation of the chest pulse sensor can be affected by magnetic interference caused by high power lines or other sources. If it is suspected that this is a problem, try relocating the treadmill.
- The CR2032 battery may need to be replaced (see the back cover of this manual).

OPERATION AND ADJUSTMENT

THE PERFORMANT LUBE™ WALKING BELT

Your treadmill features a walking belt coated with PERFORMANT LUBE™, a high-performance lubricant. **IMPORTANT: Never apply silicone spray or other substances to the walking belt or the walking platform. Such substances will deteriorate the walking belt and cause excessive wear.**

HOW TO PLUG IN THE POWER CORD

This product must be earthed. If it should malfunction or break down, earthing provides a path of least resistance for electric current to reduce the risk of electric shock. This product is equipped with a power cord having an equipment-earthing conductor and an earthing plug. **Important: If the power cord is damaged, it must be replaced with a manufacturer-recommended power cord.**

See drawing 1. Plug the indicated end of the power cord into the socket on the treadmill.

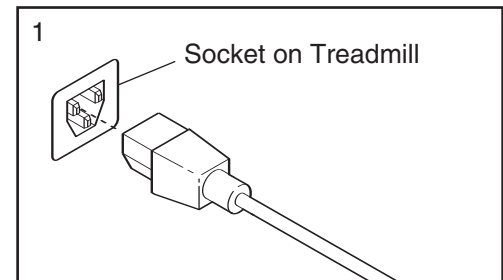

See drawing 2. Press the pins on the power cord into the metal clips in the adapter as shown. Close the adapter cover over the end of the power cord and tighten the screw in the adapter. **Important: Make sure that the adapter cover is secure and the screw has been tightened before using the power cord.**

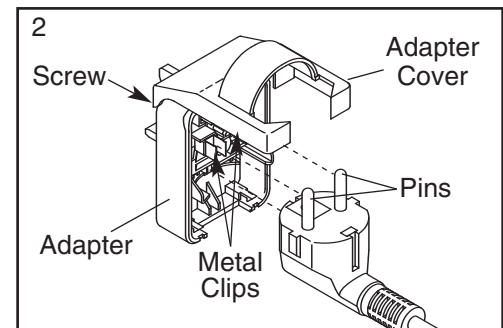

See drawing 3. Plug the power cord into an appropriate outlet that is properly installed and earthed in accordance with all local codes and ordinances. **Important: The treadmill is not compatible with GFCI-equipped outlets.**

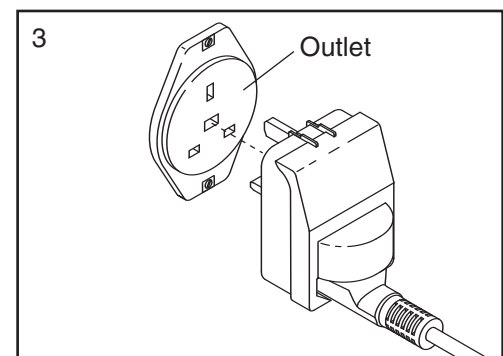

⚠ DANGER: Improper connection of the equipment-earthing conductor can result in an increased risk of electric shock. Check with a qualified electrician or serviceman if you are in doubt as to whether the product is properly earthed. Do not modify the plug provided with the product—if it will not fit the outlet, have a proper outlet installed by a qualified electrician.

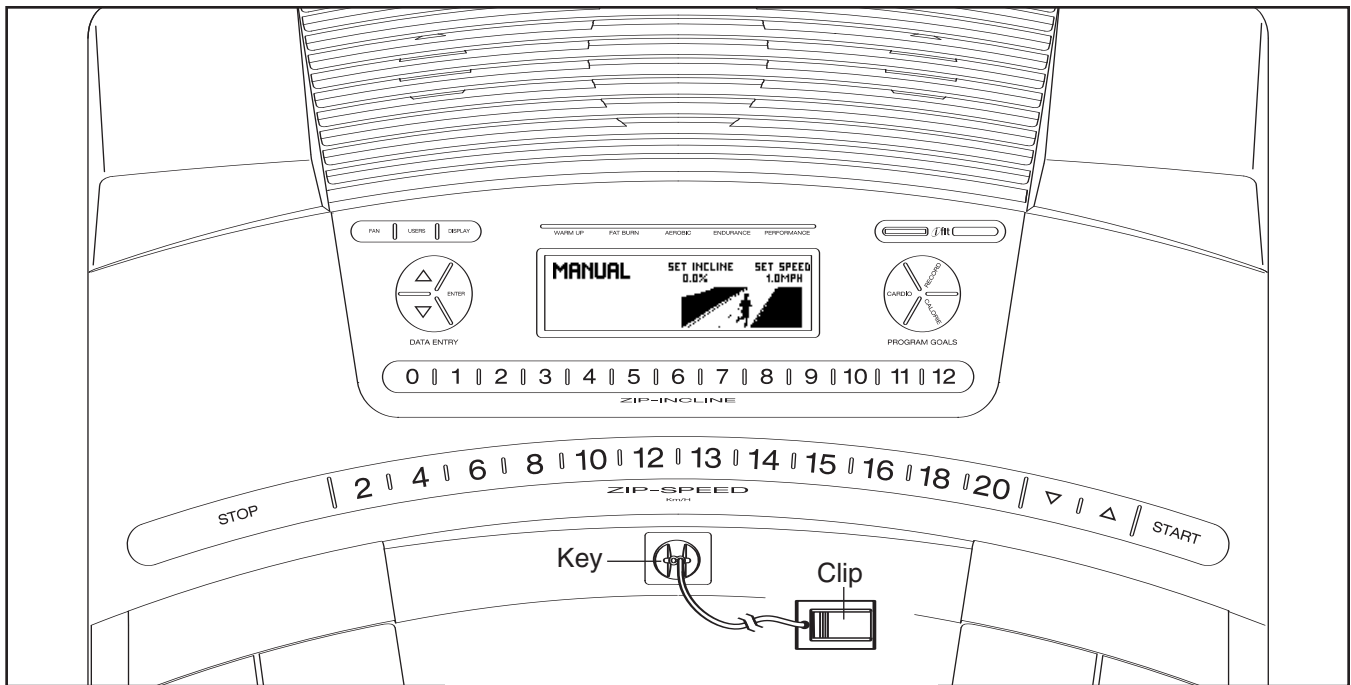

FEATURES OF THE CONSOLE

The treadmill console offers an impressive array of features designed to make your workouts more effective and enjoyable. When the manual mode of the console is selected, the speed and incline of the treadmill can be changed with the touch of a button. As you exercise, the console will display continuous exercise feedback. You can even measure your heart rate using the handgrip pulse sensor or the chest pulse sensor (see page 10).

In addition, the console features seven Cardio programs and three Calorie programs. Each program automatically controls the speed and incline of the treadmill as it guides you through an effective workout. You can even create your own Record programs and save them for future use. The console also offers two Pulse programs that control the speed and incline of the treadmill to help you keep your heart rate near target heart rate settings. Note: The Pulse programs require the use of the chest pulse sensor.

The console also features the new iFIT Interactive Workout system. The iFIT system enables the console

to accept iFIT Interactive Workout Cards containing workout programs designed to help you achieve specific fitness goals. For example, lose unwanted pounds with the 8-week Weight Loss program, or train for a long-distance run with the Marathon program. iFIT programs automatically control the treadmill while the voice of a personal trainer coaches you and motivates you through every step of your workout. One iFIT Card is included. Additional iFIT Cards are available separately. **To purchase iFIT Cards at any time, go to www.iFIT.com or call the telephone number on the front cover of this manual. iFIT Cards are also available at select stores.**

To turn on the power, follow the steps on page 13. To use the manual mode, see page 15. To use a Cardio program, see page 17. To create and use a Record program, see pages 19 and 20. To use a Pulse program, see page 21. To use an iFIT card, see page 23.

Note: If there is a sheet of clear plastic on the console, peel off the clear plastic.

HOW TO TURN ON THE POWER

- 1 Plug in the power cord (see page 11). Next, locate the on/off switch on the treadmill frame near the power cord. Make sure that the on/off switch is in the on position.

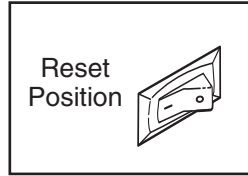

- 2 Stand on the foot rails of the treadmill. Find the clip attached to the key (see page 12), and slide the clip securely onto the waistband of your clothes. Next, insert the key into the console. After a moment, the display will light. **Important: In an emergency situation, the key can be pulled from the console, causing the walking belt to slow to a stop. Test the clip by carefully taking a few steps backward; if the key is not pulled from the console, adjust the position of the clip.**

Note: To prevent damage to the walking platform, wear clean athletic shoes while using the treadmill. The first time the treadmill is used, observe the alignment of the walking belt, and center the walking belt if necessary (see page 27).

HOW TO PERSONALIZE CONSOLE SETTINGS

The console features a users mode that allows you to designate yourself as User 1 or User 2, view your workout history, and enter user information before you begin exercising.

The console also features a settings mode that allows you to select a system of measurement for the console, turn on and turn off the demo mode, enter an audio trainer setting, adjust the volume and contrast settings of the console, and turn on and turn off the welcome screen.

Follow the steps below to personalize console settings.

- 1 **Select the users mode.**

To select the users mode, press the Users button. The console can keep track of workout history and save information for two different users.

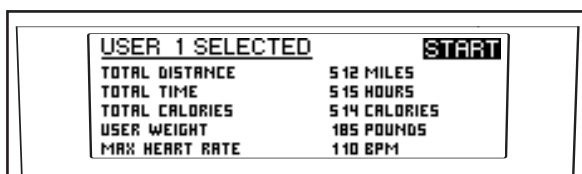

When the Users button is pressed, the words "User 1 Selected" or "User 2 Selected" will appear in the display. To identify yourself as User 1 or User 2, press the Users button once or twice.

Important: To highlight options within the menu, press the Data Entry increase and decrease buttons.

- 2 **View your workout history if desired.**

The display will show the total number of miles or kilometers that the walking belt has moved, the total number of hours that the treadmill has been used, and the total number of calories that the user has burned.

To reset any of the totals, first highlight the total that you want to reset and press the Enter button. Then, highlight NO or YES and press the Enter button.

- 3 **Enter user information.**

Highlight the words USER WEIGHT and then press the Enter button. Next, press the Data Entry increase and decrease buttons to enter your weight. Then, press the Enter button.

If you want to enter a maximum target heart rate (see HOW TO USE A PULSE PROGRAM on page 21), first highlight MAX. HEART RATE and press the Enter button. Next, press the Data Entry increase and decrease buttons to enter a maximum target heart rate. Then, press the Enter button.

To exit the users mode, highlight START and then press the Enter button.

- 4 **Select the settings mode.**

To select the settings mode, first remove the key from the console. Then, hold down the Stop button while reinserting the key into the console.

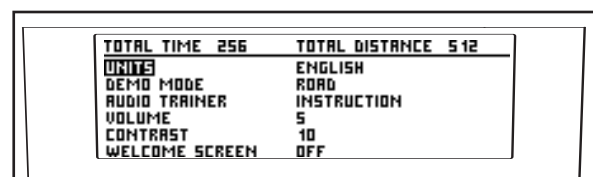

When the settings mode is selected, the display will show the word ENGLISH or METRIC to indicate which system of measurement is selected. To change the system of measurement, first highlight UNITS and press the Enter button. Next, press the Data Entry increase or decrease button to select the desired system of measurement. Then, press the Enter button.

TOTAL TIME 256	TOTAL DISTANCE 512
UNITS	ENGLISH
DEMO MODE	ROAD
AUDIO TRAINER	INSTRUCTION
VOLUME	5
CONTRAST	10
WELCOME SCREEN	OFF

The display will also show the words DEMO MODE and the current setting: OFF, LOGO, ROAD, or PROGRAMS. The “demo mode” can be used while the treadmill is displayed in a store. While the demo mode is selected, the power cord can be plugged in, the key can be removed from the console, and the display will remain on. The console buttons will not function. To select a demo mode, highlight DEMO MODE and then press the Enter button. Next, press the Data Entry increase or decrease button to highlight OFF (to turn off the demo mode), LOGO (to display a logo), ROAD (to display an animation of a runner on a road), or PROGRAMS (to display previews of various programs). Then, press the Enter button.

You can select an audio setting if desired. When you use an iFIT Card, a personal trainer will guide you through your workouts and instruct you how to purchase more iFIT Cards if “Instruction” is selected as your audio setting. If you select the “On”

setting, your personal trainer will simply guide you through your iFIT workouts. If you select “Off,” you will hear no audio guidance during your workouts. To change the audio setting, first highlight AUDIO TRAINER and press the Enter button. Next, press the Data Entry increase or decrease button to select the desired audio setting. Then, press the Enter button.

You can adjust the volume of your personal trainer’s voice by highlighting VOLUME, pressing the Enter button, and then pressing the Data Entry increase and decrease buttons to select a volume setting. Then, press the Enter button.

The contrast of the display can also be adjusted. To adjust the contrast of the display, first highlight CONTRAST and press the Enter button. Next, press the increase and decrease buttons to select a contrast setting. Then, press the Enter button.

The console can also display a welcome message each time you insert the key into the console. Highlight WELCOME SCREEN and press the Enter button. Then, press the Data Entry increase or decrease button to select ON or OFF and press the Enter button.

5 When you are finished using the settings mode, remove the key.

To exit the settings mode at any time, remove the key from the console.

HOW TO USE THE MANUAL MODE

1 Insert the key into the console.

See HOW TO TURN ON THE POWER on page 13.

2 Personalize console settings if desired.

See HOW TO PERSONALIZE CONSOLE SETTINGS on page 13.

3 Select the manual mode.

Each time the key is inserted, the manual mode will be selected. If you have selected a program, press any of the program buttons repeatedly until the word **MANUAL** appears in the display. Note: Make sure that an iFIT card is not inserted into the iFIT slot.

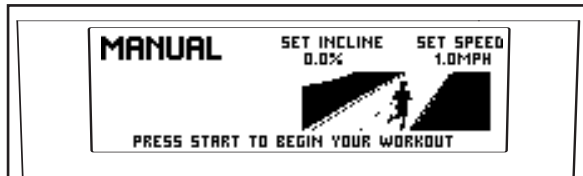

4 Start the walking belt and adjust the speed.

To start the walking belt, press the Start button, the Speed increase button next to the Start button, or one of the twelve Zip-Speed buttons.

If the Start button or the Speed increase button is pressed, the walking belt will begin to move at 2 Km/H. As you exercise, change the speed of the walking belt as desired by pressing the Speed increase and decrease buttons next to the Start button. Each time a button is pressed, the speed setting will change by 0.1 Km/H; if a button is held down, the speed setting will change in increments of 0.5 Km/H. If one of the twelve Zip-Speed buttons is pressed, the walking belt will gradually increase in speed until it reaches the selected speed setting.

To stop the walking belt, press the Stop button. To restart the walking belt, press the Start button, the

Speed increase button, or one of the twelve Zip-Speed buttons.

5 Change the incline of the treadmill as desired.

To change the incline of the treadmill, press one of the twelve Zip-Incline buttons. Each time one of the buttons is pressed, the incline will gradually increase until it reaches the selected incline setting.

6 Select a display mode and monitor your progress with the display and the intensity level bar.

As you walk or run on the treadmill, the display can show the following workout information:

- The elapsed time.
- The distance that you have walked or run.
- The speed of the walking belt.
- The incline level of the treadmill.
- The approximate number of calories you have burned.
- The approximate number of grams of carbs you have burned.
- Your walking or running pace, in minutes per mile or minutes per kilometer.
- Your heart rate. Note: Your heart rate can be displayed only while you use the handgrip pulse sensor or the chest pulse sensor.
- In addition, the display can show a “workout history”—a profile that represents the speed settings that you select during your workout. At the beginning of each minute of your workout, an additional column will appear in the profile; as you increase or decrease the speed setting, the height of the column will increase or decrease.
- The display can also show an animation of a runner on a road. As you increase or decrease the speed setting, the runner will speed up or slow down.

When the manual mode is selected, the console offers eight display modes. The display mode that you select will determine which workout information is shown. For example, the first display mode shows only the elapsed time and the distance that you have walked or run. Press the Display button repeatedly to select the desired display mode.

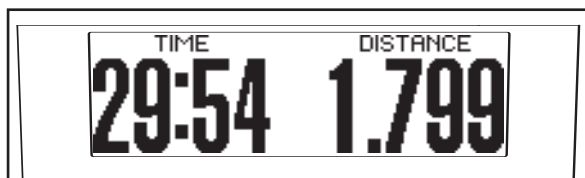

Regardless of which display mode you select, the speed or incline setting will appear in the display for a few seconds each time you change the setting. In addition, your heart rate will appear in the display for up to 40 seconds each time you use the handgrip pulse sensor or put on the chest pulse sensor. Note: If you select the display mode shown below, your heart rate will be shown in place of the approximate number of grams of carbs you have burned.

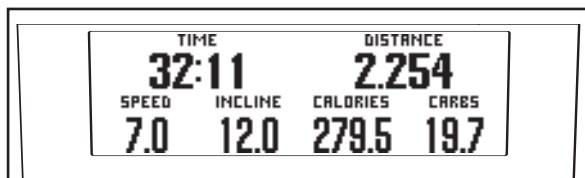

As you exercise, the intensity level bar will indicate the approximate intensity level of your exercise. For example, if eight of the indicators in the bar are lit, the bar shows that your intensity level is ideal for aerobic exercise.

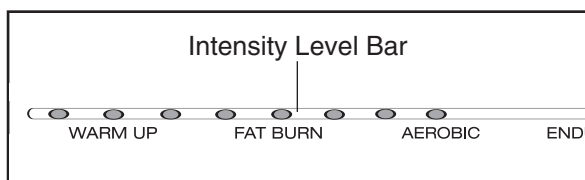

To reset the console, press the Stop button, remove the key, and then reinsert the key.

7 Measure your heart rate if desired.

Note: If you use the handgrip pulse sensor and the chest pulse sensor at the same time, the display will not show your heart rate accurately.

To use the handgrip pulse sensor, first remove the sheets of clear plastic from the metal contacts on the handgrip pulse sensor. Next, **stand on the foot rails** and hold the metal contacts—**avoid moving your hands**. When your pulse is detected, your heart rate will appear in the display. **For the most accurate heart rate reading, continue to hold the contacts for about 15 seconds.**

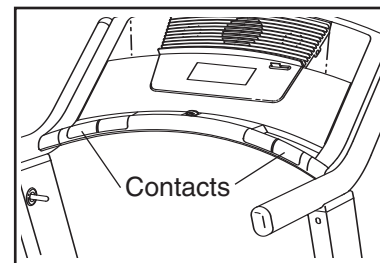

8 Turn on the fan if desired.

To turn on the fan at low speed, press the Fan button. To turn on the fan at medium speed, press the button a second time. To turn on the fan at high speed, press the button a third time. To select the auto fan mode, press the button a fourth time. When the auto fan mode is selected, the speed of the fan will automatically increase or decrease as the speed of the walking belt increases or decreases.

To turn off the fan, press the Fan button again. Note: If the fan is on when the walking belt stops, the fan will automatically turn off after a few minutes.

9 When you are finished exercising, remove the key.

Step onto the foot rails, press the Stop button, and adjust the incline of the treadmill to the lowest setting. **The incline must be at the lowest setting when the treadmill is folded to the storage position or the treadmill will become damaged.** Next, remove the key from the console and put it in a secure place.

When you are finished using the treadmill, switch the on/off switch to the “off” position and unplug the power cord.

HOW TO USE A CARDIO PROGRAM

1 Insert the key into the console.

See HOW TO TURN ON THE POWER on page 13.

2 Personalize console settings if desired.

See HOW TO PERSONALIZE CONSOLE SETTINGS on page 13.

3 Select a Cardio program.

To select a Cardio program, press the Cardio button repeatedly.

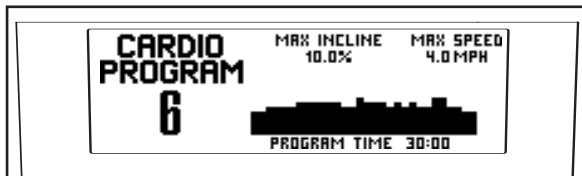

When a Cardio program is selected, the display will show the name of the program, the maximum incline setting of the program, and the maximum speed setting. In addition, a profile of the speed settings of the program will appear in the display.

Each Cardio program is divided into 30 one-minute segments. One speed setting and one incline setting are programmed for each segment. Note: The same speed setting and/or incline setting may be programmed for two or more consecutive segments.

4 Press the Start button to start the program.

A moment after the button is pressed, the treadmill will automatically adjust to the first speed and incline settings of the program. Hold the handrails and begin walking.

5 Select a display mode and monitor your progress with the display.

When a Cardio program is selected, the console offers three display modes. Press the Display button repeatedly to select the desired display mode.

If the first or second display mode is selected, a profile of the speed settings of the program will appear in the display. A small arrow below the profile will indicate your progress.

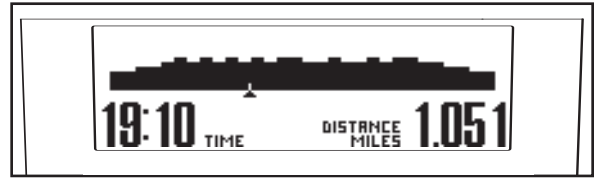

At the end of the first one-minute segment of the program, a series of tones will sound. If a different speed setting and/or incline setting is programmed for the second segment, the speed setting and/or incline setting will appear at the top of the display for a moment to alert you. The treadmill will then automatically adjust to the speed and incline settings for the second segment.

The program will continue in this way until the small arrow reaches the right end of the profile. The walking belt will then slow to a stop.

If the third display mode is selected, the display will show an animation of a runner.



At the end of the first one-minute segment of the program, a series of tones will sound. If a different speed setting is programmed for the second segment, the speed setting will move along the bottom of the display to alert you. If a different incline setting is programmed, the incline setting will appear at the top of the display for a moment. The treadmill will then automatically adjust to the speed and incline settings for the second segment.

The program will continue in this way until the last segment ends. The walking belt will then slow to a stop.

If the speed or incline setting for the current segment is too high or too low, you can override the setting by pressing the Speed or Incline buttons; however, when the next segment begins, **the treadmill will automatically adjust to the speed and incline settings for the next segment.**

To stop the program at any time, press the Stop button. To restart the program, press the Start button. The walking belt will begin to move at 2 Km/H. When the next segment of the program begins, the treadmill will automatically adjust to the speed and incline settings for the next segment.

6 Measure your heart rate if desired.

See step 7 on page 16.

7 Turn on the fan if desired.

See step 8 on page 16.

8 When you are finished exercising, remove the key from the console.

When the program ends, **make sure that the incline of the treadmill is at the lowest setting.** Next, remove the key from the console and put it in a secure place.

When you are finished using the treadmill, switch the on/off switch to the “off” position and unplug the power cord.

HOW TO USE A CALORIE PROGRAM

1 Insert the key into the console.

See HOW TO TURN ON THE POWER on page 13.

2 Personalize console settings if desired.

See HOW TO PERSONALIZE CONSOLE SETTINGS on page 13. Note: You must enter your weight (see step 3 on page 13) for the console to most accurately calculate the number of calories to be burned during your workout.

3 Select a Calorie program.

To select a Calorie program, press the Calorie button one, two, or three times.

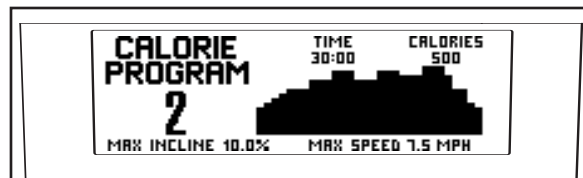

When a Calorie program is selected, the display will show the name of the program, the length of the program, the calorie goal (the number of calories to be burned during the program), the maximum incline setting of the program, and the maximum speed setting. In addition, a profile of the speed settings of the program will appear in the display.

4 Press the Start button to start the program.

A moment after the button is pressed, the treadmill will automatically adjust to the first speed and incline settings of the program. Hold the handrails and begin walking.

If the speed or incline setting for the current segment is too high or too low, you can override the setting by pressing the Speed or Incline buttons; however, when the next segment begins, **the treadmill will automatically adjust to the speed and incline settings for the next segment.**

5 Select a display mode and follow your progress with the display.

The Calorie program will function in the same way as a Cardio program (see step 5 on page 17), except that while you exercise, the display will show the number of calories still to be burned.

The program will end when you reach your calorie goal or when the small arrow reaches the right end of the profile, whichever occurs first. The walking belt will then slow to a stop.

6 Measure your heart rate if desired.

See step 7 on page 16.

7 Turn on the fan if desired.

See step 8 on page 16.

8 When you are finished exercising, remove the key from the console.

See step 8 at the left.

HOW TO CREATE A RECORD PROGRAM

1 Insert the key into the console.

See HOW TO TURN ON THE POWER on page 13.

2 Personalize console settings if desired.

See HOW TO PERSONALIZE CONSOLE SETTINGS on page 13.

3 Select a Record program.

To select a Record program, press the Record button once or twice.

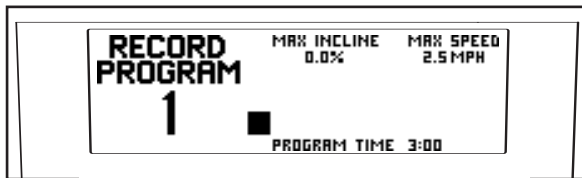

If the Record program has not yet been defined, the display will show a program time of three minutes. If the program time is more than three minutes, see HOW TO USE A RECORD PROGRAM on page 20.

Each Record program is divided into one-minute segments. One speed setting and one incline setting can be programmed for each segment.

4 Press the Start button to start the program.

A moment after the button is pressed, the walking belt will begin to move. Hold the handrails and begin walking.

5 Select a display mode and program the desired speed and incline settings.

When a Record program is selected, the console offers three display modes. Press the Display button repeatedly to select the desired display mode.

To program a speed setting and an incline setting for the first one-minute segment of the program, simply adjust the speed and incline of the treadmill as desired by pressing the Speed and Incline buttons.

When the first segment ends, a series of tones will sound and the current speed setting and the current incline setting will be saved in memory.

Program a speed setting and an incline setting for the second segment as described above. Continue programming speed and incline settings for up to 30 segments.

When you are finished with your workout, press the Stop button twice. The Record program will then be saved in memory.

6 When you are finished exercising, remove the key from the console.

See step 8 on page 18.

HOW TO USE A RECORD PROGRAM

1 Insert the key into the console.

See HOW TO TURN ON THE POWER on page 13.

2 Personalize console settings if desired.

See HOW TO PERSONALIZE CONSOLE SETTINGS on page 13.

3 Select a Record program.

To select a Record program, press the Record button once or twice.

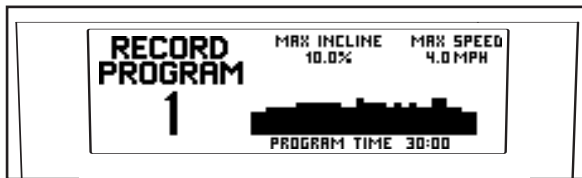

When a Record program is selected, the display will show the name of the program, the maximum incline setting of the program, and the maximum speed setting. In addition, a profile of the speed settings of the program will appear in the display.

Note: If the display shows a program time of three minutes, see HOW TO CREATE A RECORD PROGRAM on page 19.

Each Record program is divided into one-minute segments. One speed setting and one incline setting are programmed for each segment.

4 Press the Start button to start the program.

A moment after the button is pressed, the treadmill will automatically adjust to the first speed and

incline settings that you programmed previously. Hold the handrails and begin walking.

5 Select a display mode and monitor your progress with the display.

The Record program will function in the same way as a Cardio program (see step 5 on page 17).

If desired, you can redefine the program while using it. **To change the speed or incline setting for the current segment**, simply press the Speed or Incline buttons. When the current segment ends, the new setting will be saved in memory. **To increase the length of the program**, first wait until the program ends. Then, press the Start button and program speed and incline settings for as many additional segments as desired; Record programs can have up to 30 segments. When you have added as many segments as desired, press the Stop button twice. **To decrease the length of the program**, press the Stop button twice at any time before the program ends.

6 Measure your heart rate if desired.

See step 7 on page 16.

7 Turn on the fan if desired.

See step 8 on page 16.

8 When you are finished exercising, remove the key from the console.

See step 8 on page 18.

HOW TO USE A PULSE PROGRAM

⚠ CAUTION: If you have heart problems, or if you are over 60 years of age and have been inactive, do not use the Pulse programs. If you are taking medication regularly, consult your physician to find whether the medication will affect your exercise heart rate.

Follow the steps below to use a Pulse program.

1 Put on the chest pulse sensor.

Note: You must wear the chest pulse sensor to use a Pulse program.

2 Insert the key into the console.

See HOW TO TURN ON THE POWER on page 13.

3 Personalize console settings if desired.

See HOW TO PERSONALIZE CONSOLE SETTINGS on page 13.

4 Select a Pulse program.

To select a Pulse program, press the Cardio button repeatedly until you reach the Pulse programs.

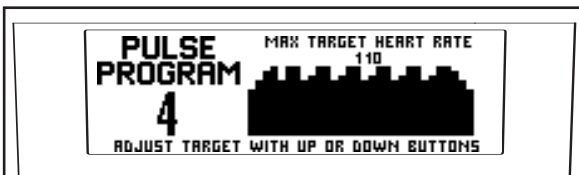

When a Pulse program is selected, the display will show the name of the program and the maximum target heart rate setting of the program. In addition, a profile of the target heart rate settings of the program will appear in the display.

The Pulse programs are each divided into one-minute segments. During the first Pulse program, the same target heart rate setting is programmed for all segments (except for the first two segments). During the second Pulse program, one target heart rate setting is programmed for each

segment. Note: The same target heart rate setting may be programmed for two or more consecutive segments.

5 Adjust the maximum target heart rate setting if desired.

To adjust the maximum target heart rate setting, press the Data Entry increase and decrease buttons beside the Enter button (see EXERCISE INTENSITY on page 29). To adjust the target heart rate setting quickly, hold down one of the buttons.

6 Press the Start button to start the program.

A moment after the button is pressed, the walking belt will begin to move. Hold the handrails and begin walking.

7 Select a display mode and monitor your progress with the display.

When a Pulse program is selected, the console offers two display modes. Press the Display button to select the desired display mode.



Regardless of which display mode you select, a profile of the target heart rate settings of the program will appear in the display. A white line representing your heartbeat will also appear; each time a heartbeat is detected, an additional peak will appear in the line. A small arrow below the profile will indicate your progress.

During each one-minute segment of the program, the console will compare your heart rate to the current target heart rate setting. If your heart rate is too far below or above the target heart rate setting, the speed of the walking belt or the incline of the treadmill will automatically change to bring your heart rate closer to the target heart rate setting. Each time the speed or incline changes, the speed setting and the incline setting will appear at the top of the display for a moment to alert you.

When each segment ends, a series of tones will sound.

If the speed or incline setting for the current segment is too high or too low, you can override the setting by pressing the Speed or Incline buttons; however, when the console compares your heart rate to the current target heart rate setting, the speed or incline of the treadmill may automatically change.

To stop the program at any time, press the Stop button. To restart the program, press the Start button. The walking belt will begin to move at 2 Km/H. When the console compares your heart rate to the current target heart rate setting, the speed or incline of the treadmill may automatically change.

If the first Pulse program is selected, the program will continue until you stop it by pressing the Stop

button. If the second Pulse program is selected, the program will continue until the small arrow reaches the right end of the profile. The walking belt will then slow to a stop.

8 Turn on the fan if desired.

See step 8 on page 16.

9 When you are finished exercising, remove the key from the console.

See step 8 on page 18.

HOW TO USE AN IFIT CARD

1 Insert the key into the console.

See HOW TO TURN ON THE POWER on page 13.

2 Personalize console settings if desired.

See HOW TO PERSONALIZE CONSOLE SETTINGS on page 13.

3 Insert an iFIT Card and select a program.

To use an iFIT program, insert an iFIT Card into the iFIT slot; make sure that the iFIT Card is oriented so the metal contacts are on top and are inserted into the iFIT slot.

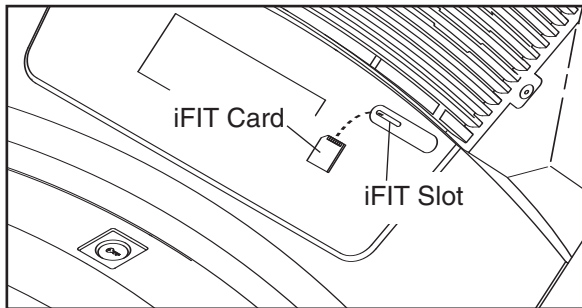

Next, select an iFIT program by pressing the Data Entry increase or decrease button. When an iFIT program is selected, the display will show the name of the program, the maximum incline setting and the maximum speed setting of the program, and the program time. In addition, a profile of the speed settings of the program will appear in the display.

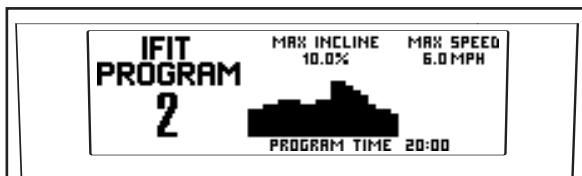

Each iFIT program is divided into several one-minute segments. One speed setting and one incline setting are programmed for each segment. Note: The same speed setting and/or incline setting may be programmed for two or more consecutive segments.

4 Press the Start button to start the program.

A moment after the button is pressed, the treadmill will automatically adjust to the first speed and incline settings of the program. Hold the handrails and begin walking.

5 Select a display mode and monitor your progress with the display and the intensity level bar.

When an iFIT program is selected, the console offers three display modes (see step 6 on page 15). Press the Display button repeatedly to select the desired display mode. **If the first or second display mode is selected**, a profile of the speed settings of the program will appear in the display. A small arrow below the profile will indicate your progress.

During the program, a personal trainer will guide you through the workout. You can adjust the volume or select an audio setting for your personal trainer (see step 4 on pages 13 and 14).

If the speed or incline setting for the current segment is too high or too low, you can override the setting by pressing the Speed or Incline buttons; however, when the next segment begins, **the treadmill will automatically adjust to the speed and incline settings for the next segment.**

To stop the program at any time, press the Stop button. To restart the program, press the Start button. The walking belt will begin to move at 2 Km/H. When the next segment of the program begins, the treadmill will automatically adjust to the speed and incline settings for the next segment.

6 Turn on the fan if desired.

See step 8 on page 16.

7 When you are finished exercising, remove the key from the console.

See step 8 on page 18.

CAUTION: Always remove iFIT Cards from the iFIT slot when you are not using them.

HOW TO FOLD AND MOVE THE TREADMILL

HOW TO FOLD THE TREADMILL FOR STORAGE

Before folding the treadmill, adjust the incline to the lowest position. If this is not done, the treadmill may be permanently damaged. Next, unplug the power cord.

CAUTION: You must be able to safely lift 45 pounds (20 kg) to raise, lower, or move the treadmill.

1. Hold the end of the treadmill near the location indicated by the arrow at the right. **To decrease the possibility of injury, bend your legs and keep your back straight as you raise the frame.** Raise the frame about halfway to the vertical position.

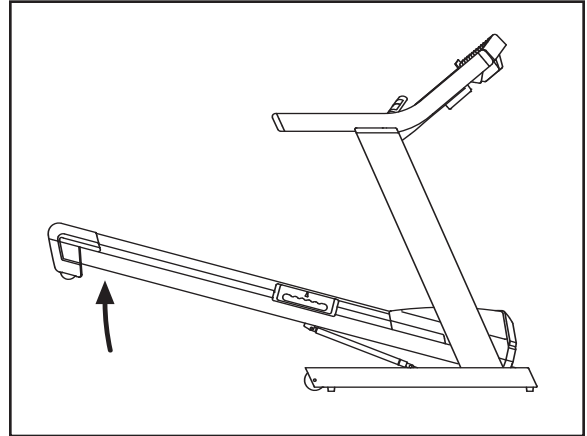

2. Move your right hand to the position shown and hold the treadmill firmly. Using your left hand, pull the latch knob to the left and hold it. Raise the frame until the catch is aligned with the latch pin. Slowly release the latch knob. **Make sure that the latch pin is fully inserted into the catch.**

To protect the floor or carpet from damage, place a mat under the treadmill. Keep the treadmill out of direct sunlight. Do not leave the treadmill in the storage position in temperatures above 85° Fahrenheit.

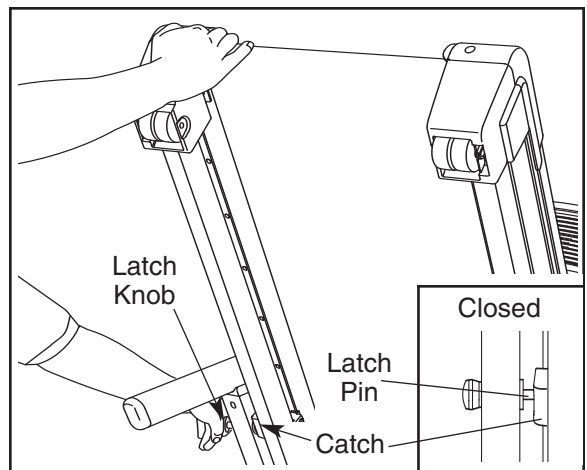

HOW TO MOVE THE TREADMILL

1. Before moving the treadmill, convert the treadmill to the storage position as described above.
2. Hold the treadmill and place one foot against one of the wheels.
3. Tilt the treadmill back until it rolls on the wheels. Carefully move the treadmill to the desired location. **To reduce the risk of injury, use extreme caution while moving the treadmill. Do not attempt to move the treadmill over an uneven surface.**
4. Place one foot against one of the wheels, and carefully lower the treadmill until the base is in the storage position.

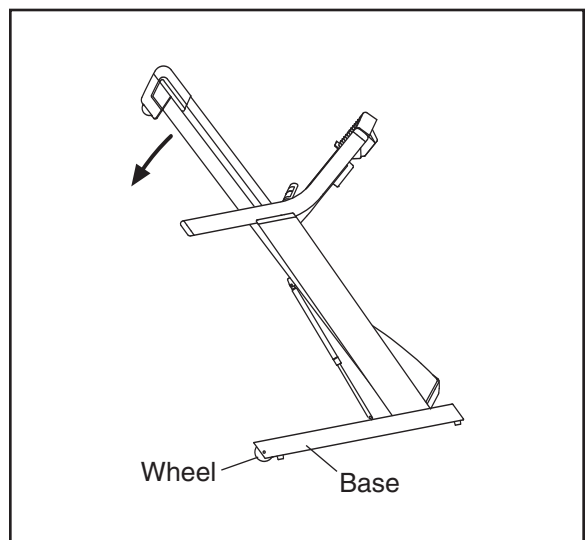

HOW TO LOWER THE TREADMILL FOR USE

1. Hold the upper end of the treadmill with your right hand as shown. Using your left hand, pull the latch knob to the left and hold it. Pivot the frame down until it is past the latch pin. Then, slowly release the latch knob.

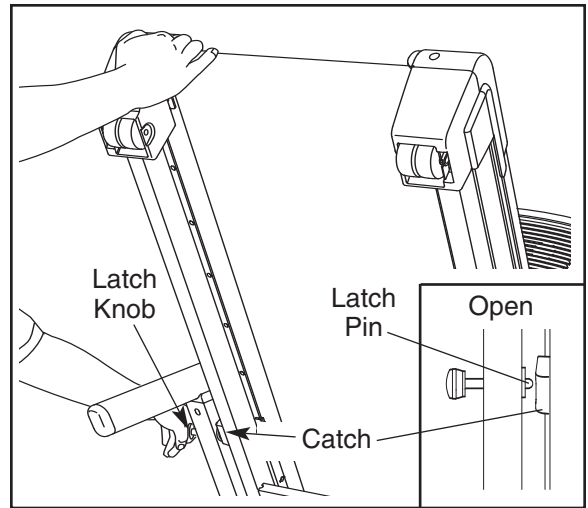

2. Hold the frame firmly with both hands, and lower it to the floor. **To decrease the possibility of injury, bend your legs and keep your back straight.**

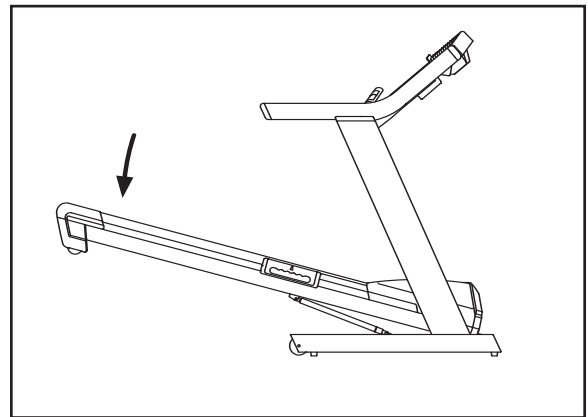

TROUBLESHOOTING

Most treadmill problems can be solved by following the steps below. Find the symptom that applies, and follow the steps listed. If further assistance is needed, please see the front cover of this manual.

PROBLEM: The power does not turn on

SOLUTION: a. Make sure that the power cord is plugged into a properly earthed outlet (see page 11). If an extension cord is needed, use only a 3-conductor, 1 mm² (14-gauge) cord that is no longer than 1.5 m (5 ft.). Important: The treadmill is not compatible with GFCI-equipped outlets.

b. After the power cord has been plugged in, make sure that the key is inserted into the console.

c. Check the circuit breaker located on the treadmill near the power cord. If the switch protrudes as shown, the circuit breaker has tripped. To reset the circuit breaker, wait for five minutes and then press the switch back in.

d. Check the on/off switch located on the treadmill near the power cord. The switch must be in the "on" position.

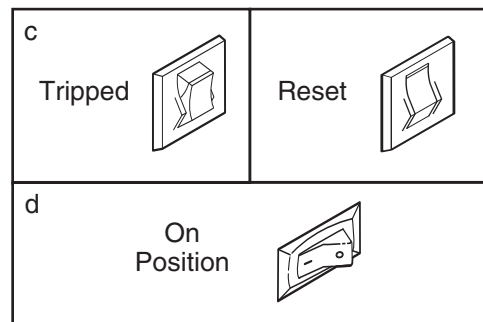

PROBLEM: The power turns off during use

SOLUTION: a. Check the circuit breaker located on the treadmill frame near the power cord (see the drawing above). If the circuit breaker has tripped, wait for five minutes and then press the switch back in.

b. Make sure that the power cord is plugged in. If the power cord is plugged in, unplug it, wait for five minutes, and then plug it back in.

c. Remove the key from the console. Reinsert the key into the console.

d. Make sure that the on/off switch is in the "on" position (see d. above).

e. If the treadmill still will not run, see the front cover of this manual.

PROBLEM: The displays of the console do not function properly

SOLUTION: a. Remove the key from the console and **UNPLUG THE POWER CORD**. Place the treadmill in the storage position (see HOW TO FOLD AND MOVE THE TREADMILL on page 24).

Next, remove the two indicated 3/4" Screws (4).

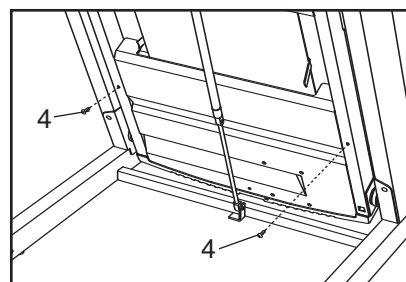

Lower the treadmill (see HOW TO LOWER THE TREADMILL FOR USE on page 25). Remove the four indicated 3/4" Screws (4), and remove the Hood (44).

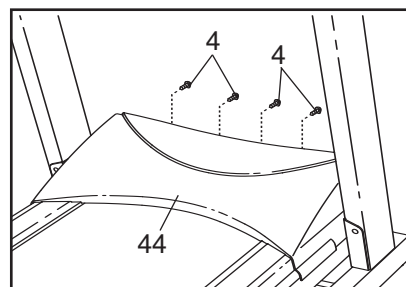

Next, locate the Reed Switch (14) and the Magnet (12) on the left side of the Pulley (11). Turn the Pulley until the Magnet is aligned with the Reed Switch. **Make sure that the gap between the Magnet and the Reed Switch is about 3 mm (1/8 in.)** . If necessary, loosen the indicated Screw (29), move the Reed Switch slightly, and then retighten the Screw. Reattach the hood and run the treadmill for a few minutes to check for a correct speed reading.

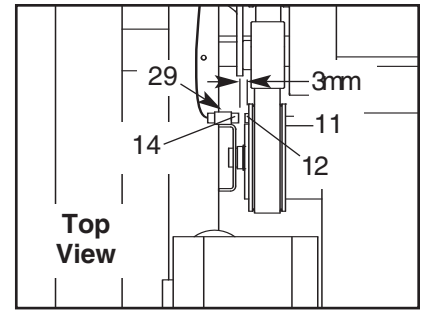

PROBLEM: The walking belt slows when walked on

SOLUTION: a. Use only a single-outlet surge suppressor that meets all of the specifications described on page 11.

b. If the walking belt is overtightened, treadmill performance may decrease and the walking belt may be permanently damaged. Remove the key and **UNPLUG THE POWER CORD**. Using the included hex key, turn both rear roller adjustment bolts counterclockwise 1/4 of a turn. When the walking belt is properly tightened, you should be able to lift each edge of the walking belt 3 to 4 inches off the walking platform. Be careful to keep the walking belt centered. Then, plug in the power cord, insert the key, and run the treadmill for a few minutes. Repeat until the walking belt is properly tightened.

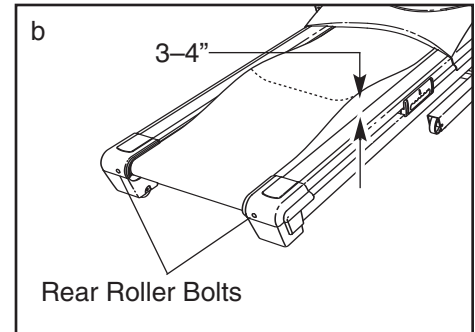

c. If the walking belt still slows when walked on, please see the front cover of this manual.

PROBLEM: The walking belt is off-center or slips when walked on

SOLUTION: a. If the walking belt is off-center, first remove the key and **UNPLUG THE POWER CORD**. **If the walking belt has shifted to the left**, use the hex key to turn the left rear roller bolt clockwise 1/2 of a turn; **if the walking belt has shifted to the right**, turn the bolt counterclockwise 1/2 of a turn. Be careful not to overtighten the walking belt. Then, plug in the power cord, insert the key, and run the treadmill for a few minutes. Repeat until the walking belt is centered.

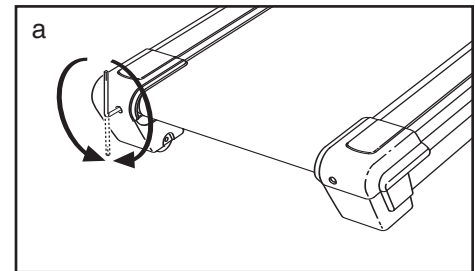

b. If the walking belt slips when walked on, first remove the key and **UNPLUG THE POWER CORD**. Using the hex key, turn both rear roller bolts clockwise 1/4 of a turn. When the walking belt is correctly tightened, you should be able to lift each edge of the walking belt 3 to 4 inches off the walking platform. Be careful to keep the walking belt centered. Then, plug in the power cord, insert the key, and walk on the treadmill for a few minutes. Repeat until the walking belt is properly tightened.

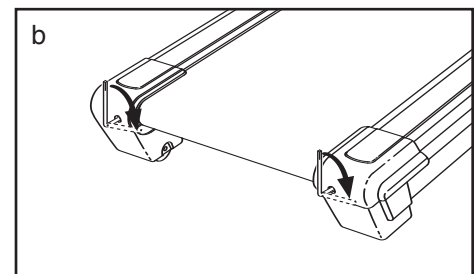

PROBLEM: The incline of the treadmill does not change correctly

SOLUTION: a. With the key in the console, press one of the Incline buttons. **While the incline is changing, remove the key.** After a few seconds, re-insert the key. The treadmill will automatically rise to the maximum incline level and then return to the minimum level. This will recalibrate the incline system.

PROBLEM: The chest pulse sensor does not function properly

SOLUTION: a. If the chest pulse sensor does not function properly, see CHEST PULSE SENSOR TROUBLESHOOTING on page 10.

b. If the chest pulse sensor still does not function properly, the battery should be changed. To replace the battery, locate the battery cover on the back of the sensor unit. Insert a coin into the slot in the cover and turn the cover counterclockwise to the “open” position. Remove the cover.

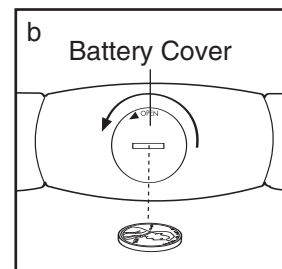

Remove the old battery from the sensor unit. Insert a new **CR 2032 battery**, making sure that the writing is on top. In addition, make sure that the rubber gasket is in place in the sensor unit. Replace the battery cover and turn it to the closed position.

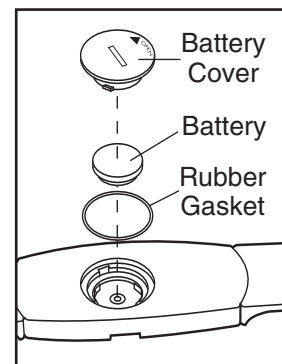

EXERCISE GUIDELINES

⚠️ WARNING: Before beginning this or any exercise program, consult your physician. This is especially important for individuals over the age of 35 or individuals with pre-existing health problems.

The pulse sensor is not a medical device. Various factors, including the user's movement, may affect the accuracy of heart rate readings. The pulse sensor is intended only as an exercise aid in determining heart rate trends in general.

The following guidelines will help you to plan your exercise program. For more detailed exercise information, obtain a reputable book or consult your physician.

EXERCISE INTENSITY

Whether your goal is to burn fat or to strengthen your cardiovascular system, the key to achieving the desired results is to exercise with the proper intensity. The proper intensity level can be found by using your heart rate as a guide. The chart below shows recommended heart rates for fat burning and aerobic exercise.

165	155	145	140	130	125	115	❤️
145	138	130	125	118	110	103	❤️
125	120	115	110	105	95	90	❤️
20	30	40	50	60	70	80	

To find the proper heart rate for you, first find your age near the bottom of the chart (ages are rounded off to the nearest ten years). Next, find the three numbers above your age. The three numbers define your “training zone.” The lower two numbers are recommended heart rates for fat burning; the highest number is the recommended heart rate for aerobic exercise.

Fat Burning

To burn fat effectively, you must exercise at a relatively low intensity level for a sustained period of time. During the first few minutes of exercise, your body uses easily accessible *carbohydrate calories* for energy. Only after the first few minutes does your body

begin to use stored *fat calories* for energy. If your goal is to burn fat, adjust the speed or incline of the treadmill until your heart rate is near the lowest number in your training zone.

For maximum fat burning, adjust the speed or incline of the treadmill until your heart rate is near the middle number in your training zone.

Aerobic Exercise

If your goal is to strengthen your cardiovascular system, your exercise must be “aerobic.” Aerobic exercise is activity that requires large amounts of oxygen for prolonged periods of time. This increases the demand on the heart to pump blood to the muscles, and on the lungs to oxygenate the blood. For aerobic exercise, adjust the speed or incline of the treadmill until your heart rate is near the highest number in your training zone.

WORKOUT GUIDELINES

Each workout should include the following three parts:

A Warm-up—Start each workout with 5 to 10 minutes of stretching and light exercise. A proper warm-up increases your body temperature, heart rate and circulation in preparation for exercise.

Training Zone Exercise—After warming up, increase the intensity of your exercise until your pulse is in your training zone for 20 to 60 minutes. (During the first few weeks of your exercise program, do not keep your pulse in your training zone for longer than 20 minutes.) Breathe regularly and deeply as you exercise—never hold your breath.

A Cool-down—Finish each workout with 5 to 10 minutes of stretching to cool down. This will increase the flexibility of your muscles and will help prevent post-exercise problems.

EXERCISE FREQUENCY

To maintain or improve your condition, complete three workouts each week, with at least one day of rest between workouts. After a few months, you may complete up to five workouts each week if desired. The key to success is to make exercise a regular and enjoyable part of your everyday life.

PART LIST—Model No. NETL81906.0

R0606A

To locate the parts listed below, see the EXPLODED DRAWING attached in the center of this manual.

Key No.	Qty.	Description	Key No.	Qty.	Description
1	2	Foot Rail Cover	51	1	Right Rear Foot
2	2	Foot Rail	52	4	Rear Wheel
3	2	Platform Cushion	53	2	Rear Wheel Bolt
4	51	3/4" Screw	54	1	Right Rear Endcap
5	1	Catch	55	2	Rear Roller Washer
6	1	Walking Platform	56	2	Rear Roller Adj. Bolt
7	2	Belt Guide	57	1	Hex Key
8	4	Belt Guide Screw	58	1	Left Rear Foot
9	2	Front Isolator	59	1	Left Rear Endcap
10	2	Platform Bolt, Front	60	1	Rear Roller
11	1	Front Roller/Pulley	61	2	Platform Nut
12	1	Magnet	62	2	Platform Bolt, Rear
13	24	1/2" Screw	63	1	Hood Cover
14	1	Reed Switch Clip	64	6	Handrail Bolt
15	1	Left Incline Rod Bushing	65	1	Console Base
16	2	Lift Arm	66	1	Console
17	2	Lift Pivot Bolt	67	1	Console Fan Grill
18	2	Hood Mount	68	1	Static Decal
19	2	Lift Arm Spacer	69	9	Electronics Screw
20	1	Reed Switch Wire	70	1	Access Door
21	1	Idler Wheel Nut	71	6	Upright Star Washer
22	1	Idler Wheel	72	6	Upright Bolt
23	1	Idler Wheel Bolt	73	1	Left Upright
24	1	Lift Motor Bolt, Bottom	74	1	Right Upright
25	1	Idler Arm Spacer	75	1	Upright Wire
26	1	Idler Arm	76	6	Cage Nut
27	1	Idler Arm Spring	77	4	Bracket Star Washer
28	1	Motor Belt	78	7	Washer
29	5	Reed Switch Screw	79	2	Endcap Screw
30	2	Long Lift Pivot Bolt	80	2	Base Endcap
31	1	Drive Motor	81	4	Base Pad
32	2	Motor Bolt	82	4	1" Tek Screw
33	4	Electronics Bracket Nut	83	1	Base
34	1	Electronics Bracket	84	1	Frame Ground Wire
35	1	Front Endcap	85	2	Wheel Bolt
36	1	Controller	86	2	Wheel
37	1	Incline Rod	87	3	Caution Decal
38	9	Nut	88	1	Gas Spring
39	1	Lift Motor	89	1	Key/Clip
40	1	Lift Motor Bolt, Top	90	6	Handrail Star Washer
41	3	1/2" Outlet Screw	91	1	Releaseable Tie
42	2	Cushion Adjustor	92	2	Tie Clamp
43	1	Outlet Assembly	93	10	8" Plastic Tie
44	1	Hood	94	2	Handrail Endcap, Bottom
45	4	Hood Clip	95	2	Handrail Spacer
46	2	Grommet	96	1	Latch Sleeve
47	1	Walking Belt	97	1	Top Handrail Endcap
48	1	Frame	98	1	Filter
49	16	Cushion Track Screw	99	1	Handrail
50	1	Transformer	100	1	Latch Assembly

Key No.	Qty.	Description	Key No.	Qty.	Description
101	1	Latch Warning Decal	114	1	Pulse Receiver
102	1	Spring Pin Kit	115	2	Pulse Receiver Screw
103	2	Console Ground Wire	116	1	Cable Ground Wire
104	1	Idler Arm Bolt	#	1	16" Green Wire, F/R
105	1	Right Incline Rod Bushing	#	1	4" Green Wire w/Toroid, F/R
106	1	Incline/Controller Wire	#	1	4" Green Wire, F/R
107	1	Incline Stop Bracket	#	3	6" Black Wire, M/R
108	1	Stop Bracket Spacer	#	1	6" Black Wire, M/F
109	1	7.5" Plastic Tie	#	1	6" White Wire, 2F
110	1	Power Cord	#	1	6" Blue Wire, 2 F
111	1	Power Cord Adapter	#	1	User's Manual
112	1	Chest Pulse Sensor			
113	1	Chest Pulse Strap			

#These parts are not illustrated

EXPLODED DRAWING—Model No. NETL81906.0

R0606A

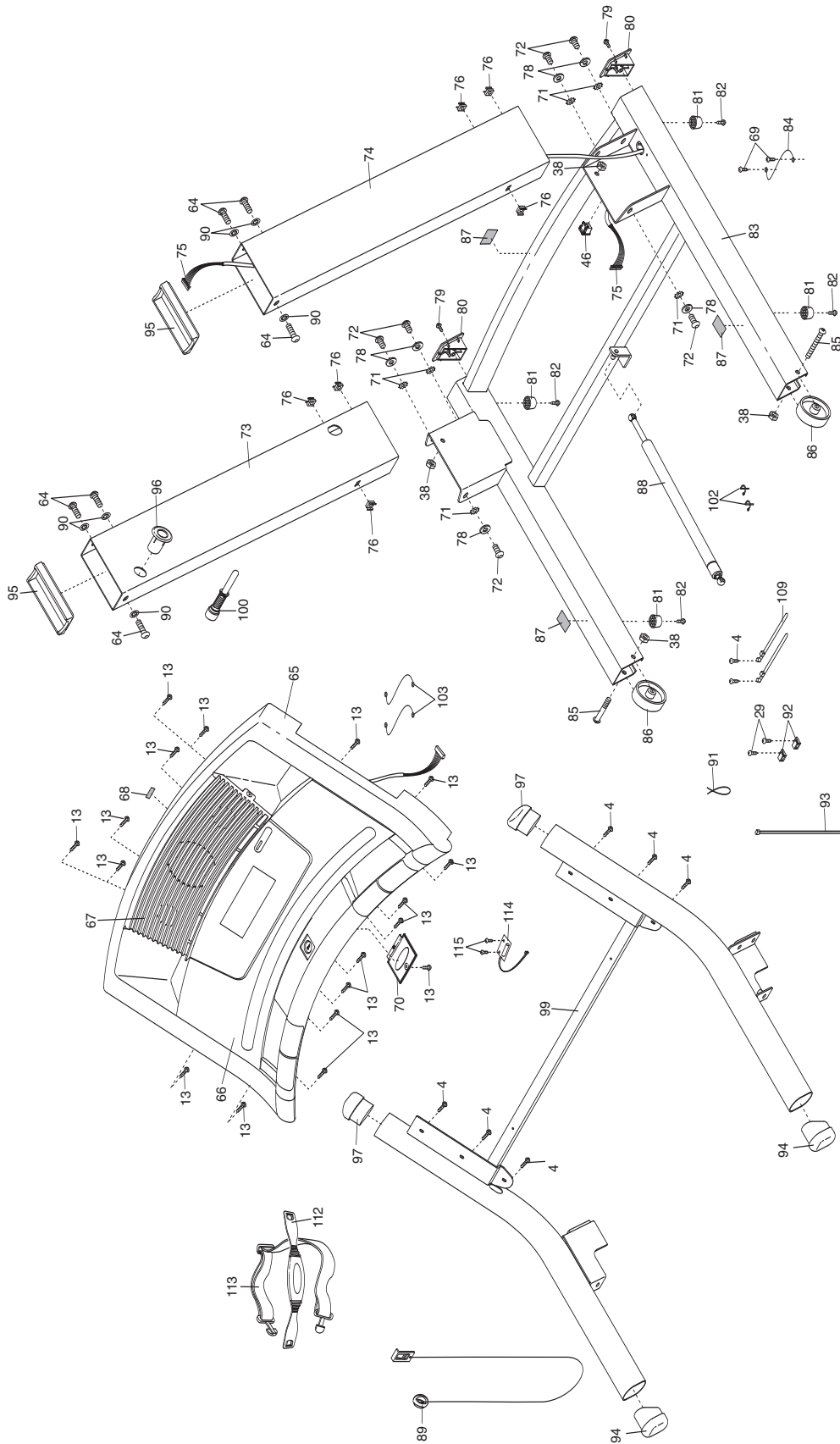

ORDERING REPLACEMENT PARTS

To order replacement parts, contact the ICON Health & Fitness, Ltd. office, or write:

ICON Health & Fitness, Ltd.
Customer Service Department
Unit 4, Revie Road Industrial Estate
Revie Road
Beeston
Leeds, LS118JG
UK

Tel:

08457 089 009

Outside the UK: 0 (444) 113 387 7133
Fax: 0 (444) 113 387 7125

To help us assist you, please be prepared to give the following information:

- The MODEL NUMBER OF THE PRODUCT (NETL81906.0)
- The NAME OF THE PRODUCT (NordicTrack® EX 3300 treadmill)
- The SERIAL NUMBER OF THE PRODUCT (see the front cover of this manual)
- The KEY NUMBER AND DESCRIPTION OF THE PART(S) (see the PART LIST on pages 30 and 31 and the EXPLODED DRAWING attached in the center of this manual)