



Z100-DP

SPECIFICATION SHEET

15 [381] DIAMETER MAIN ROOF DRAIN LOW SILHOUETTE DOME W/ TOP-SET® DECK PLATE

TAG _____

Dimensional Data (inches and [mm]) are Subject to Manufacturing Tolerances and Change Without Notice

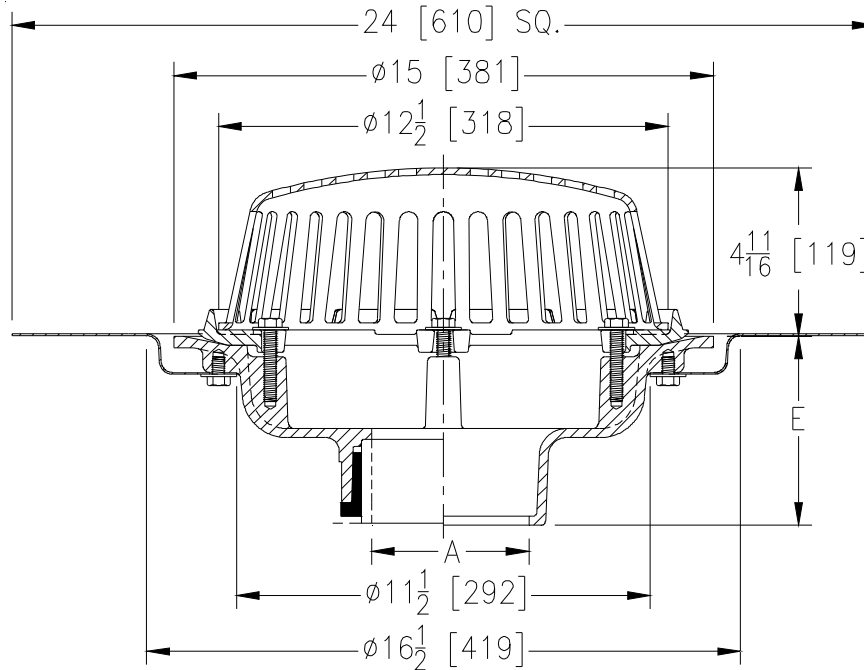

A Pipe Size In.	Approx. Wt. Lbs. [kg]	Dome Open Area Sq. In. [cm ²]
2-3-4 [51-76-102]	36 [16]	103 [665]
5-6 [127-152]	37 [17]	
8 [203]	38 [17]	

ENGINEERING SPECIFICATION: ZURN Z100-DP

15 [381] Diameter roof drain. Dura-Coated cast iron body with combination membrane flashing clamp/gravel guard, top-set® deck plate, and low silhouette Poly-Dome.

OPTIONS (Check/specify appropriate options)

PIPE SIZE

- 2 thru 6,8 [51 thru 152,203]
- 2 thru 6,8 [51 thru 152,203]
- 2 thru 6,8 [51 thru 152,203]
- 2,3,4 [51,76,102]
- 6 [152]

(Specify size/type) OUTLET

- _____ IC Inside Caulk
- _____ IP Threaded
- _____ NH No-Hub
- _____ NL Neo-Loc
- _____ NL Neo-Loc

E BODY HT. DIM.

- 5 1/4 [133]
- 3 3/4 [95]
- 5 1/4 [133]
- 4 9/16 [116]
- 5 7/16 [112]

PREFIXES

- _____ Z D.C.C.I. Body with Poly-Dome*
- _____ ZA D.C.C.I. Body with Aluminum Dome
- _____ ZC D.C.C.I. Body with Cast Iron Dome
- _____ ZRB D.C.C.I. Body with Plain Bronze Dome

SUFFIXES

- _____ -AR Acid Resistant Epoxy Coated Finish
- _____ -AW 3/4 [19] to 4 [102] Adj. Water Level Regulator
- _____ -BS Bronze Mesh Screen Over Dome
- _____ -E Static Extension 1 [25] thru 4 [102] (Specify Ht.)
- _____ -EA Adjustable Extension Assembly
1 3/4 [44] thru 3 1/2 [89]
- _____ -ES Static Extension with Secondary Clamp
- _____ -FG Flush Grate
- _____ -G Galvanized Cast Iron
- _____ -GD Galvanized Cast Iron Dome
- _____ -HD 6 3/4 [171] High Aluminum Dome
(148 Sq. In. [955 cm²] Open Area)
- _____ -DR Top-Set® Drain Riser
- _____ -SC Secondary Clamping Collar
- _____ -SS Stainless Steel Mesh Screen Over Dome
- _____ -VP Vandal Proof Secured Top
- _____ -W2 2 [51] Internal Water Dam
- _____ -W3 3 [76] Internal Water Dam
- _____ -W4 4 [102] Internal Water Dam
- _____ -XJ Vertical Expansion Joint (See Z190)
- _____ -84 Stainless Steel Perforated Gravel Guard
- _____ -85 Stainless Steel Perforated Extension
- _____ -89 2 [51] High External Water Dam
- _____ -90 90° Threaded Side Outlet Body

*REGULARLY FURNISHED UNLESS OTHERWISE SPECIFIED

REV. A DATE: 7/15/10 C.N. NO. 111384

DWG. NO. 66808 PRODUCT NO. Z100-DP