



Z100-234

15 [381] DIAMETER ROOF DRAIN W/ PERFORATED EXTENSION, AUXILIARY SIDE OUTLET, AND LOW SILHOUETTE POLY-DOME

SPECIFICATION SHEET

TAG _____

Dimensional Data (inches and [mm]) are Subject to Manufacturing Tolerances and Change Without Notice

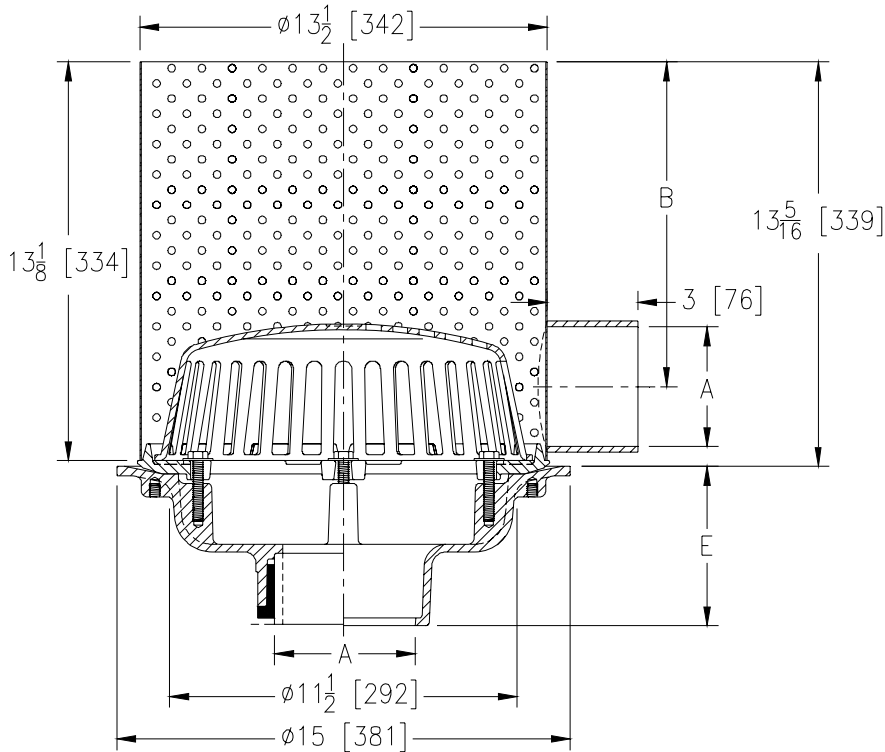

A Pipe Size In.	B	Approx. Wt. Lbs. [kg]	Dome Open Area Sq. In. [cm ²]
2,3,4 [51,76,102]	10 3/4 [273]	32 [15]	103 [665]
5,6 [127,152]	9 1/2 [241]	33 [15]	

ENGINEERING SPECIFICATION: ZURN Z100-234
15 [381] Diameter roof drain with combination gravel guard/
flashing clamp, perforated stainless steel extension with
auxiliary side outlet, and low silhouette Poly-dome.

OPTIONS (Check/specify appropriate options)

PIPE SIZE

- 2 thru 6 [51 thru 152]
- 2 thru 6 [51 thru 152]
- 2 thru 6 [51 thru 152]
- 2,3,4 [51,76,102]

(Specify size/type) **OUTLET**

- _____ IC Inside Caulk
- _____ IP Threaded
- _____ NH No-Hub
- _____ NL Neo-Loc

E BODY HT. DIM.

- 5 1/4 [133]
- 3 3/4 [95]
- 5 1/4 [133]
- 4 9/16 [116]

PREFIXES

- _____ Z D.C.C.I. Body with Poly-dome*
- _____ ZA D.C.C.I. Body with Aluminum Dome
- _____ ZC D.C.C.I. Body with Cast Iron Dome
- _____ ZRB D.C.C.I. Body with Plain Bronze Dome

SUFFIXES

- _____ -AC Angular Underdeck Clamp
- _____ -AR Acid Resistant Epoxy Coated
- _____ -BS Bronze Mesh Screen Over Dome
- _____ -C Underdeck Clamp
- _____ -DE Deck Extension
- _____ -DP Top-Set® Deck Plate (Replaces both the -C and -R)
- _____ -DR Top-Set® Drain Riser
- _____ -E Static Extension 1 [25] thru 4 [102] (Specify Ht.)

- _____ -EA Adjustable Extension Assembly
2 1/8 [54] thru 3 1/2 [89]
- _____ -EB Top-Set® Adjustable Extension Assembly
- _____ -G Galvanized Cast Iron
- _____ -R Roof Sump Receiver
- _____ -SS Stainless Mesh Screen Over Dome
- _____ -TC Neo-Loc Test Cap Gasket
(2 - 4 [51 - 102] NL Bottom Outlet Only)
- _____ -VP Vandal-Proof Secured Top
- _____ -90 90° Threaded Side Outlet Body
(2 thru 6 [51 or 152])

*REGULARLY FURNISHED UNLESS OTHERWISE SPECIFIED

REV.	DATE: 3/26/11	C.N. NO. 121080
DWG. NO. 305146		PRODUCT NO. Z100-234

ZURN INDUSTRIES, LLC ♦ SPECIFICATION DRAINAGE OPERATION ♦ 1801 Pittsburgh Ave. ♦ Erie, PA 16514

Phone: 814/455-0921 ♦ Fax: 814/454-7929 ♦ World Wide Web: www.zurn.com

In Canada: ZURN INDUSTRIES LIMITED ♦ 3544 Nashua Drive ♦ Mississauga, Ontario L4V1L2 ♦ Phone: 905/405-8272 Fax: 905/405-1292