

Owner's Manual

GG5500 Series Gasoline Generators

▲ DANGER	
Using a generator indoors CAN KILL YOU IN MINUTES . Generator exhaust contains carbon monoxide. This is a poison you cannot see or smell.	
	
NEVER use inside a home or garage, EVEN IF doors and windows are open.	Only use OUTSIDE and far away from windows, doors, and vents.
▲ PELIGRO	
Utilizar un generador dentro LE MATARA EN MINUTOS . El escape contiene monóxido de carbono, un gas tóxico usted no lo puede ver ni oler.	
	
NUNCA utilice en el hogar ni en áreas en parte encerradas tales como garajes.	SOLAMENTE uselo fuera y lejos de ventanas abiertas, puertas, y respiraderos.



Do Not Return To Store

One year or 60 hours Limited Warranty (see page22)

For customer service or warranty information call toll free

866 797 2738

Read carefully before attempting to assemble, install, operate or maintain the product described. Protect yourself and others by observing all safety information. Failure to comply with the user, s manual could result in personal injury and/or property damage! retain the user, s manual for future reference. call toll free number 866 797 2738 for parts and service.

DISCLAIMER: All pictures may not be identical to product inside box.

Distributed by  Fullerton, CA 92833



SAFETY ALERT SYMBOL: Indicates danger, warning, or caution. Attention is required in order to avoid serious personal injury.

The signal word (**DANGER, WARNING, or CAUTION**) is used with the alert symbol to alert you to special instruction about a particular operation that may be hazardous if performed incorrectly or carelessly. Observe them carefully.



DANGER: Failure to obey a safety warning **will result in serious personal injuries or deaths.**



WARNING: Failure to obey a safety warning **can result in serious personal injuries or deaths.**



CAUTION: Failure to obey a safety warning **may result in minor or moderate injuries**

CAUTION: When used without the alert symbol, could result in damage to your engine or other property.

If you do not understand any portion of this manual, about engine, please search for your dealer for explanations.

Warranty and Service Questions ?
Missing or Damaged parts
Call 866 797 2738

CONTENTS

1.SAFETY	1
2.COMPONENT IDENTIFICATION	2
3.PRE-OPERATION CHECK LIST	3
4.STARTING THE ENGINE	4
5.GENERATOR USE	5
6.STOPPING THE ENGINE	8
7.MAINTENANCE	8
8.STORAGE	10
9.TROUBLESHOOTING	10
10.WIRING DIAGRAM	11
11.SPECIFICATIONS	12
12.WHEELKIT	13
13.PARTS LIST AND DIAGRAM	13
13.1 CRANKCASE ASSY.	13
13.2 CYLINDER HEAD ASSY.	14
13.3 CAMSHAFT ASSY.	15
13.4 CRANKSHAFT ASSY.	15
13.5 CRANKSHAFT ASSY. & PISTON	16
13.6 CENTRIFUGAL TIMING IMPLEMENT ASSY.	16
13.7 INFLAME ASSY.	16
13.8 STARTER ASSY.	17
13.9 ENGINE SPROCKET COVER	17
13.10 CARBURETOR ASSY.	17
13.11 AIR CLEANER ASSY.	18
13.12 CHOKE ROD ASSY.	18
13.13 GENERATOR	19
13.14 GAS TANK ASSY.	19
13.15 PANEL ASSY.	20
13.16 MUFFLER ASSY.	20
13.17 FRAME ASSY.	21
13.18 MOTOR SHIELD ASSY.	21
14 PARTS REPLACEMENT LIMITED WARRANTY	22
15 PRODUCT REGISTRATION CARD	23

Warranty and Service Questions ?
Missing or Damaged parts
Call 866 797 2738

1. SAFETY

1.1 SAFETY LABELS

RISK OF ELECTRICAL SHOCK

This generator produces high voltage

ALWAYS ground properly before use.
DO NOT connect to any building electrical system.
NEVER use in wet or rainy conditions.
NEVER touch bare wires or receptacles.
NEVER allow children or non-qualified persons to operate.

RISK OF EXPLOSION

STOP generator before fueling.
CHECK for spilled fuel.
DO NOT operate near open flame.

Using a generator indoors CAN KILL YOU IN MINUTES.

Generator exhaust contains carbon monoxide. This is a poison you cannot see or smell.

NEVER use inside a home or garage, EVEN IF doors and windows are open.

Only use OUTSIDE and far away from windows, doors, and vents.

Avoid other generator hazards.
READ MANUAL BEFORE USE.

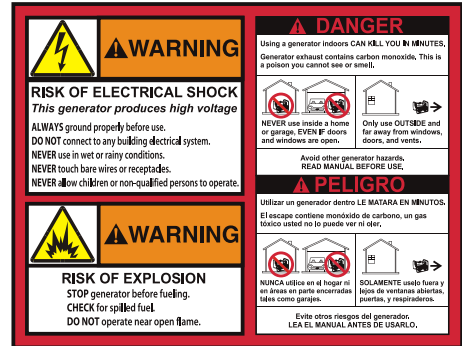

BEFORE YOU START GENERATOR

1. Please verify the engine oil is full.
 2. Please add new fuel to gas tank.
 3. Please turn the fuel valve and engine switch to the "ON" position.
 4. Place the choke lever to the "CHOKE" position.
 5. Disconnect all electrical devices.
- Generator will not start if the "OIL LEVEL" is too low.

ADD OIL

1. Remove the oil filler cap/dipstick and wipe off any oil.
2. Insert the oil filler cap/dipstick into oil filler neck but do not screw it in!
Let the filler cap/dipstick sit above the filler hole then remove it to check the oil level.
3. Add oil if the oil level is low, then reinstall the oil filler cap securely before starting.

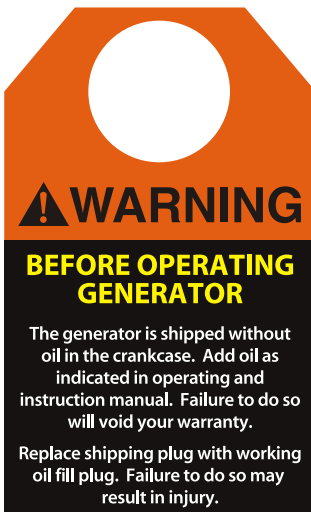
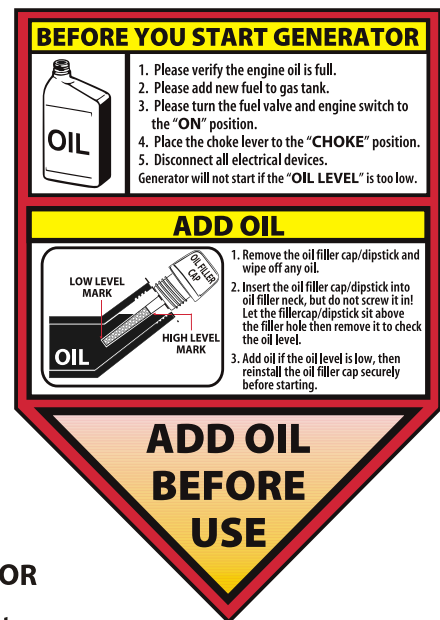

BEFORE OPERATING GENERATOR

The generator is shipped without oil in the crankcase. Add oil as indicated in operating and instruction manual. Failure to do so will void your warranty.

Replace shipping plug with working oil fill plug. Failure to do so may result in injury.



HOT EXHAUST
CONTACT MAY CAUSE BURN
DO NOT TOUCH



DO NOT RETURN TO STORE
If you are having problems with this generator, call our customer service help line.

1-866-797-2738
M-F 7:30am - 4:00pm PST

Warranty and Service Questions ?
Missing or Damaged parts
Call 866 797 2738

1.2 GENERATOR SAFETY



DO NOT USE INSIDE HOUSE.

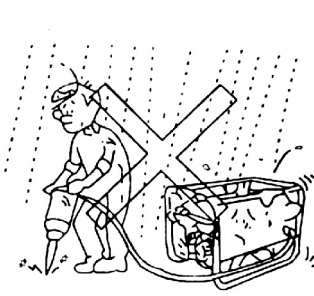

DO NOT USE IN WET SURROUNDING.



DO NOT CONNECT TO HOUSEHOLD CIRCUIT.

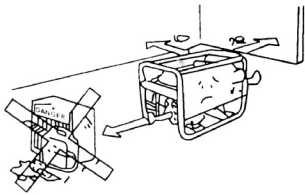

KEEP FLAMMABLE MATERIAL AT LEAST 1m(3FT).AWAY



NO SMOKING.



DO NOT SPILL.

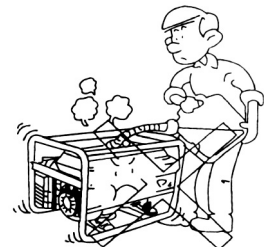

STOP ENGINE. BEFORE REFUELING

2.COMPONENT IDENTIFICATION

- | | | | |
|-------------------|--------------------|-------------------|---------------|
| 1 FUEL GAUGE | 8 HANDRAIL | 15 WHEEL | 22 SPARK PLUG |
| 2 FUEL TANK CAP | 9 FORE POLE SOCKET | 16 ENGINE SWITCH | 23 MUFFLER |
| 3 FUEL TANK | 10 DOUBLE SOCKET | 17 RECOIL STARTER | |
| 4 HOUR METER | 11 CRUTCH | 18 FUEL VALVE | |
| 5 DC PROTECTOR | 12 CIRCUIT BREAKER | 19 AIR CLEANER | |
| 6 GROUND TERMINAL | 13 VOLTMETER | 20 CHOKE ROD | |
| 7 DC TERMINALS | 14 OIL FILLER CAP | 21 FRAME | |

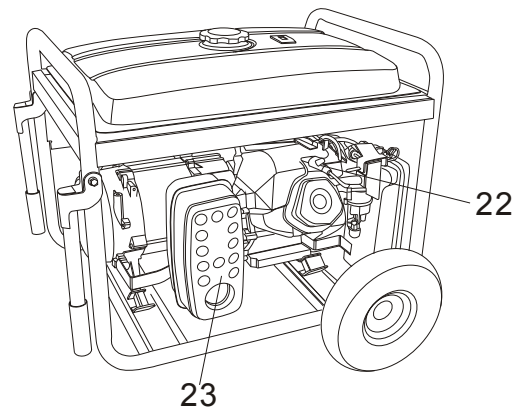
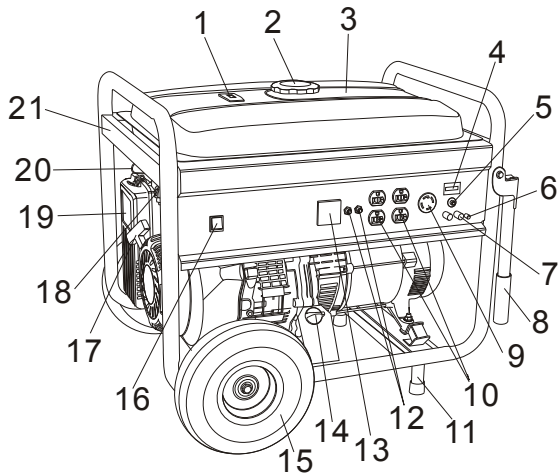

Warranty and Service Questions ?
Missing or Damaged parts
Call 866 797 2738

3.PRE-OPERATION CHECK

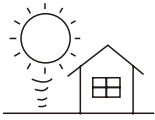

1.OIL LEVEL

CAUTION: Be sure to check the generator engine fluid levels with the generator on a level surface

Recommended oil:4-stroke motor oil service classification SJ,SL, SG or SAE 10W-30 for general temperature.

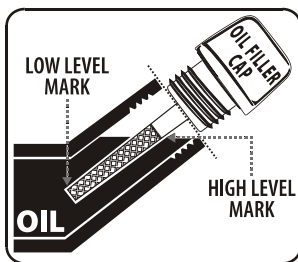

- 1.Remove the oil filler cap/dipstick and wipe off any oil.
- 2.Insert the oil filler cap/dipstick into oil filler neck,but do not screw it in! Let the filler cap/dipstick sit above the oil level.
- 3.Add oil if the oil level is low before starting.

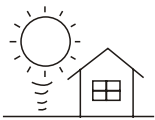

2.FUELLEVEL

- 1.Remove the fuel tank cap.

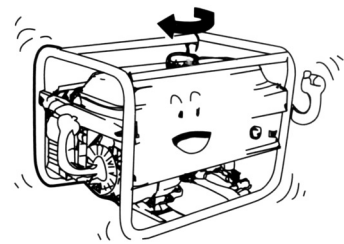
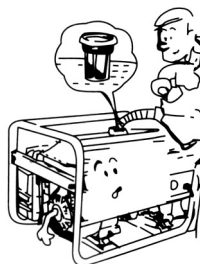
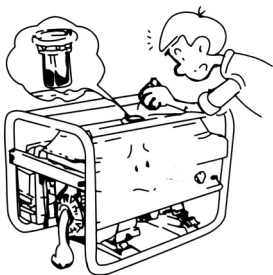

- 2.Check the fuel level if the fuel level is low.

- 3.Add the unleaded gasoline to the shoulder of the filter screen.

- 4.Install the fuel tank cap.

Warranty and Service Questions ?
Missing or Damaged parts
Call 866 797 2738

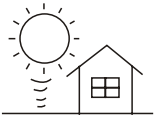

3. AIR CLEANER

1. Unsnap the air cleaner cover springs, and remove the air cleaner cover
2. Check the air cleaner element to be sure it is clean and in good condition.

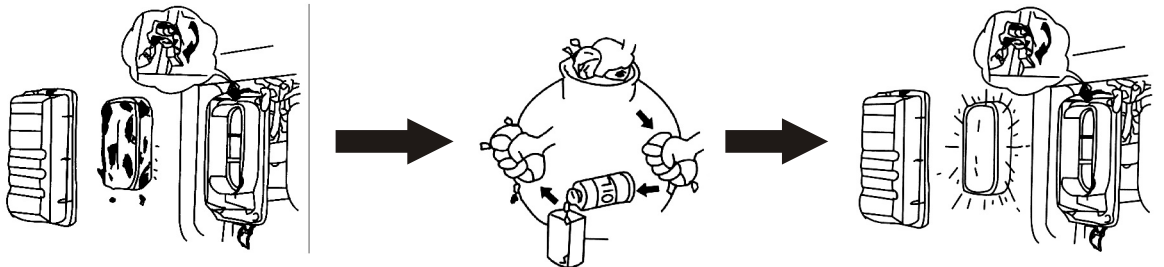

3. If it is dirty, remove and clean the element.

- (1) Wash in solvent
- (2) Squeeze
- (3) Soak oil
- (4) Squeeze dry

4. Reinstall the air cleaner element and secure the cover by setting the cover spring.

4. STARTING THE ENGINE

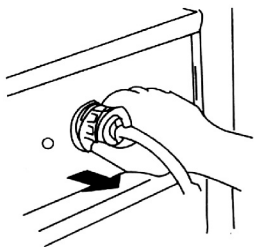

1. Disconnect any load from the AC receptacle.

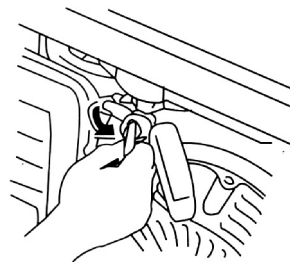

2. Turn the fuel valve to the "ON" position.

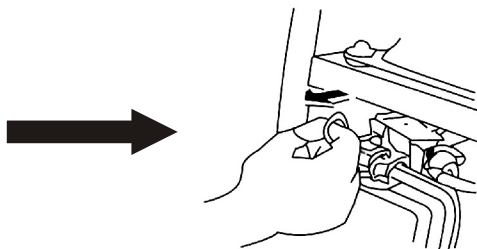

3. Pull the choke rod out to the "CLOSED" position.
Check the air cleaner element to be sure it is clean.

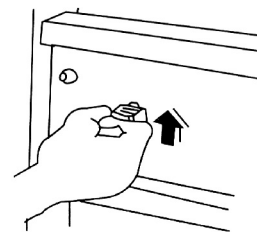

4. Turn the engine switch to the "ON" position.

Warranty and Service Questions ?
Missing or Damaged parts
Call 866 797 2738

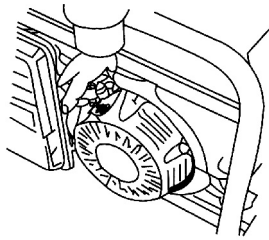

5. Pull the starter grip lightly until resistance is felt then pull briskly.

Warning: Do not allow the starter grip to snap back against the engine. Return it gently.

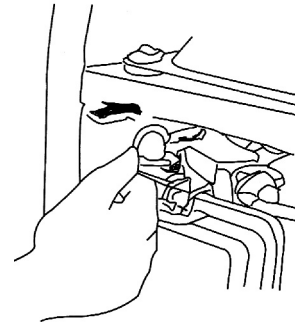

6. Push the choke rod to the "OPEN" position as the engine warms up.

5. GENERATOR USE

• To keep the generator always in top mechanical and electrical condition, observe the following:



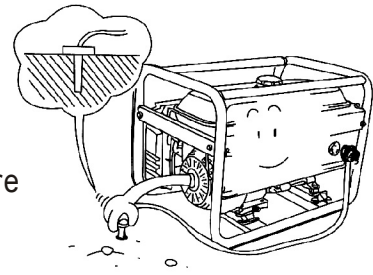

⚠ WARNING

1. To prevent electrical shock from faulty appliances, the generator should be grounded.

Connect a copper wire to the generator and the other end of wire to a metal stake driven into the ground.

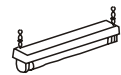
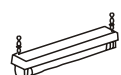

2. Combined load of the connected apparatus must not exceed the rated capacity of the generator. Electric apparatus, particularly motor-driven equipment, will draw a higher current when starting. The following table is provided for your reference when connecting such apparatus to your generator.

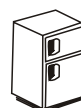
TYPE	WATTAGE		TYPICAL APPARATUS	EXAMPLE		
	STARTING	RATED		APPARATUS	STARTING	RATED
Incandescent lamp Heating appliance	X1	X1	Incandescent lamp 	Incandescent lamp 	100VA (W)	100VA (W)
			TV 	100W		
Fluorescent lamp	X2	X1.5	 Fluorescent lamp	 40W Fluorescent lamp	80VA (W)	60VA (W)
Motor driven equipment	X3-5	X2	 Refrigerator  Electric fan	Refrigerator  150W	450-750VA (W)	300VA (W)

Warranty and Service Questions ?
Missing or Damaged parts
Call 866 797 2738

3. When two or more pieces of apparatus are connected to your generator, turn them on beginning with the one drawing higher current when starting.

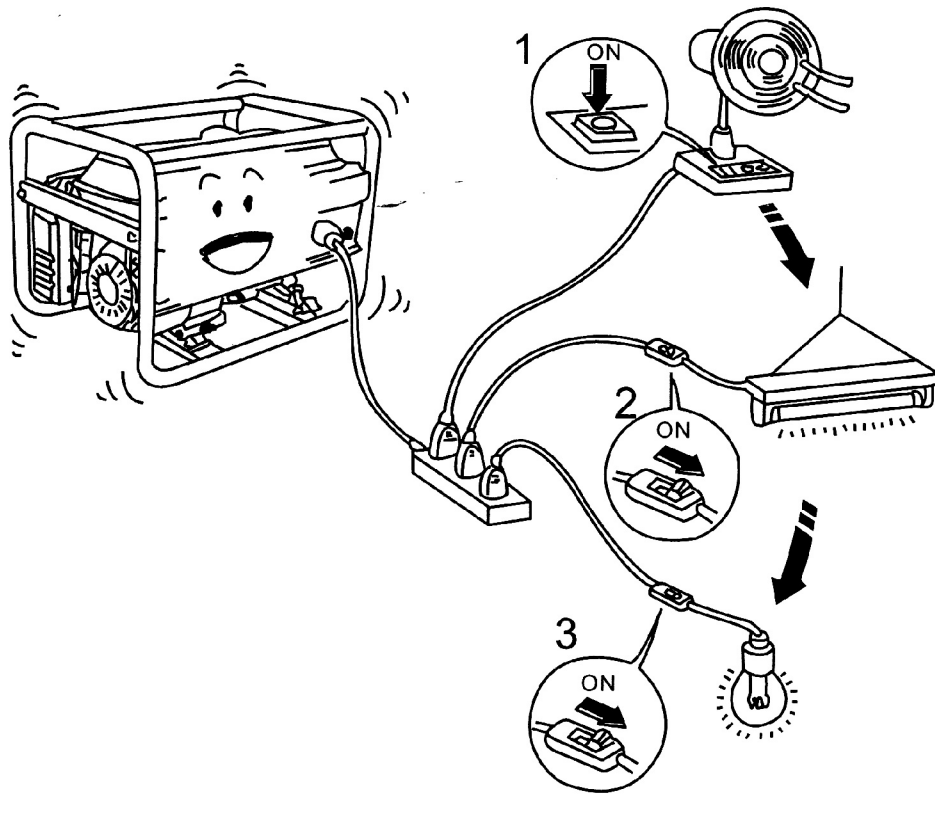

AC APPLICATION

1. Start the engine
2. Make sure that the needle on the voltmeter indicates the voltage.

3. Plug in the appliance

Note:

a: Over current will automatically turn off the AC breaker. When that is turned off, the generator shall be restarted with load reduced a few minutes thereafter.

B: Generally 5-10% variance of voltage output is allowed.

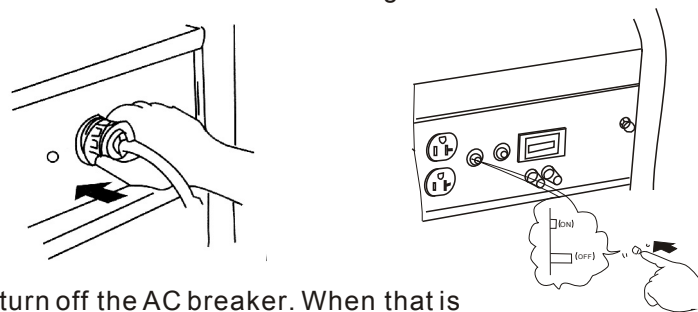

Warranty and Service Questions ?
Missing or Damaged parts
Call 866 797 2738

DC APPLICATION

The DC terminals may be used for charging 12V automotive-type batteries only

1. Connect the charging cables to the battery terminal.

2. Start the engine and charge the battery

NOTE:

An overloaded DC circuit will trip the DC circuit breaker (push button comes out) if this happens. Check the short circuit or counter connection and wait a few minutes before pushing the circuit protector.

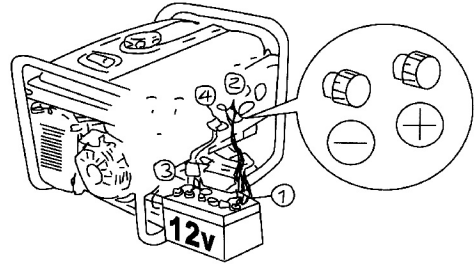

3. Stop the engine, then disconnect the charging cables in the reverse order of connection.

(1) ON (2) OFF

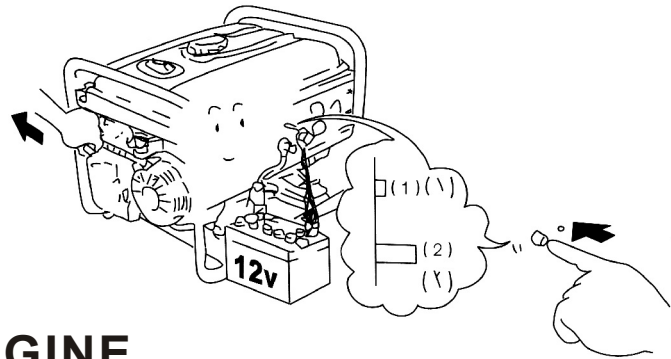

6. STOPPING THE ENGINE

1. Turn off all electrical appliances.

2. Turn the engine switch to the "OFF" position.

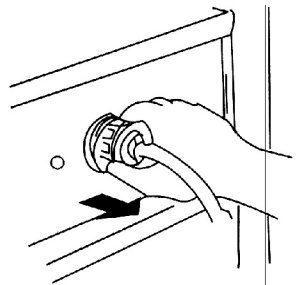

3. Disconnect the electrical appliance.

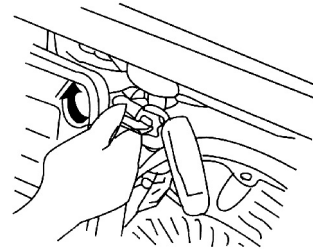

4. Turn the fuel valve to the "OFF" position.

NOTE: To stop the engine in an emergency, turn the engine switch OFF.

Warranty and Service Questions ?
Missing or Damaged parts
Call 866 797 2738

7.MAINTENANCE

(1):These items shoule be serviced by a dealer.

(2):Every 3 years



Check



Change



Clean



Check-Readjust

			First month or	Every 3 months or	Every 6 months or	Every year or	SEE page
Engine oil							P.3
							P.9
Air cleaner							P.3
							P.3
Fuel strainer							P.9
Battery fluid level							-
Spark plug							P.9
Valve Clearance						(1)	-
Combustion Chamber						(1)	-
Fuel line							-

1.OIL CHANGE

- 1.Remove the oil filler cap.
- 2.Remove the drain plug and drain the oil.
- 3.Dispose of oil property.

4.Install the drain plug and tighten it securely.

5.Refill with the motor oil(see 3 page)and check the oil level

ENGINE OIL CAPACITY:37.2oz(1.1 Liter)

6.Install the oil filler cap.

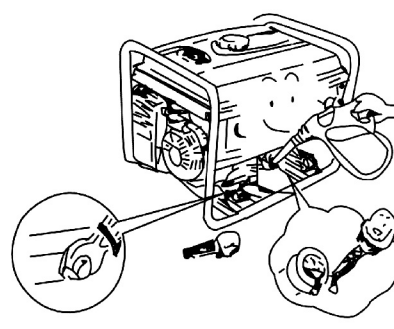
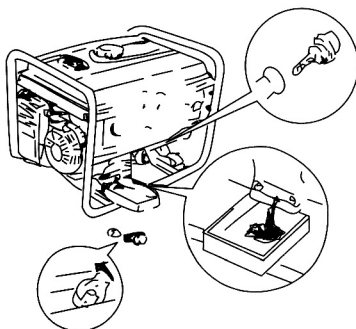

Recommended oil: 4-stroke motor oil service classification SJ,SL,SG or SAE10W-30 for general temperature.

Warranty and Service Questions ?
Missing or Damaged parts
Call 866 797 2738

2. AIR CLEANER (See 4 page)

3. SPARK PLUG

TYPE: F7RTC (NGK-BPR6ES)

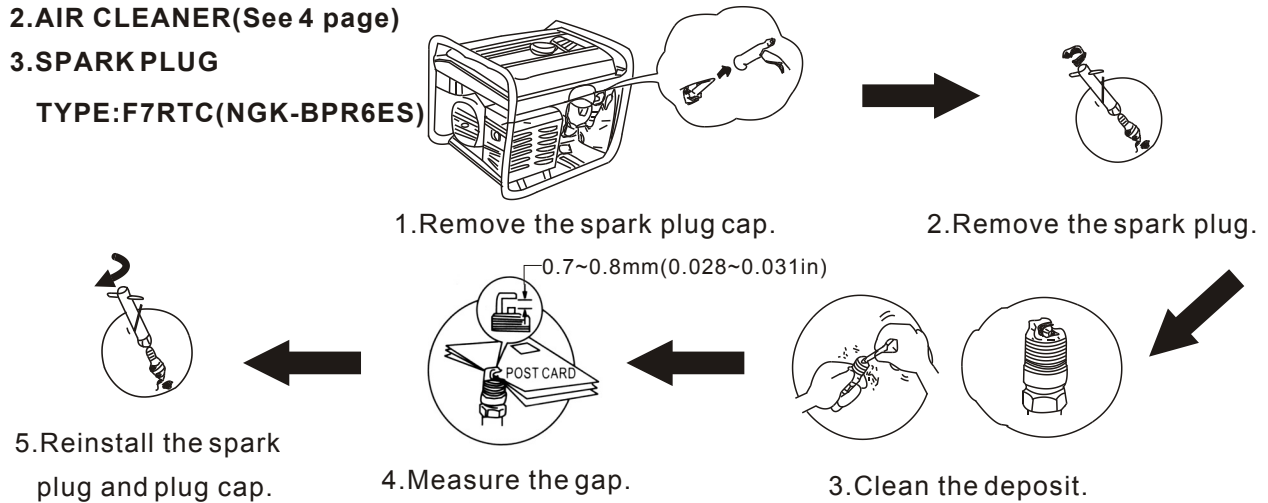

4. FUEL STRAINER

1. Turn the fuel valve to the OFF position and remove the sediment cup and filter screen.



2. Clean the sediment cup and fuel filter screen.



3. Install the fuel filter screen and sediment cup.

8. STORAGE

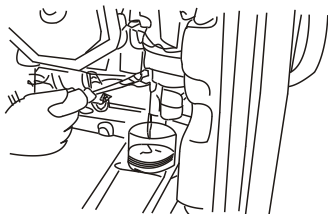

1. Close the fuel valve, drain the fuel from the fuel tank.

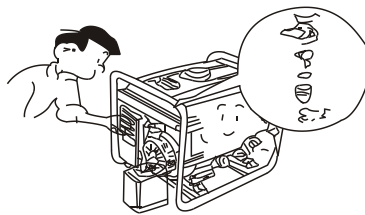

2. Drain the fuel from the carburetor.

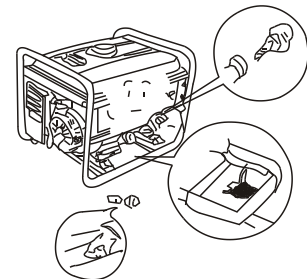

3. Remove the oil filler cap and drain plug to drain the oil.

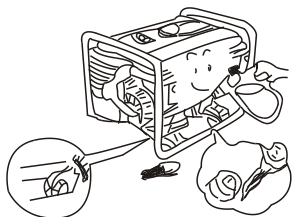

4. Tighten the oil drain plug and fill the engine with new oil to the filler neck.

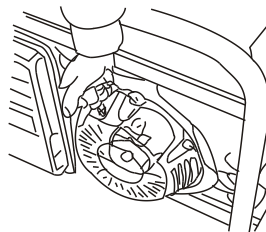

5. Pull the starter grip carefully until resistance is felt.

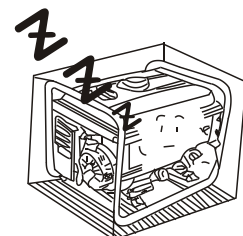

6. Store the generator in a clean area.

Warranty and Service Questions ?
Missing or Damaged parts
Call 866 797 2738

9.TROUBLE SHOOTING

ENGINE DOES NOT START:

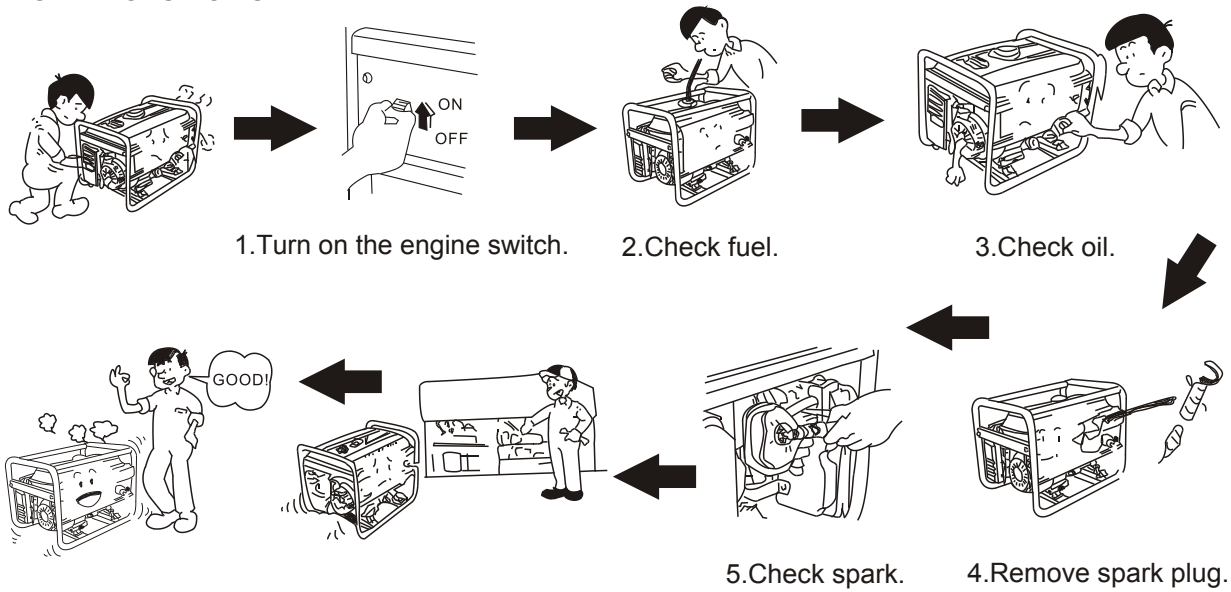

NO ELECTRICITY:

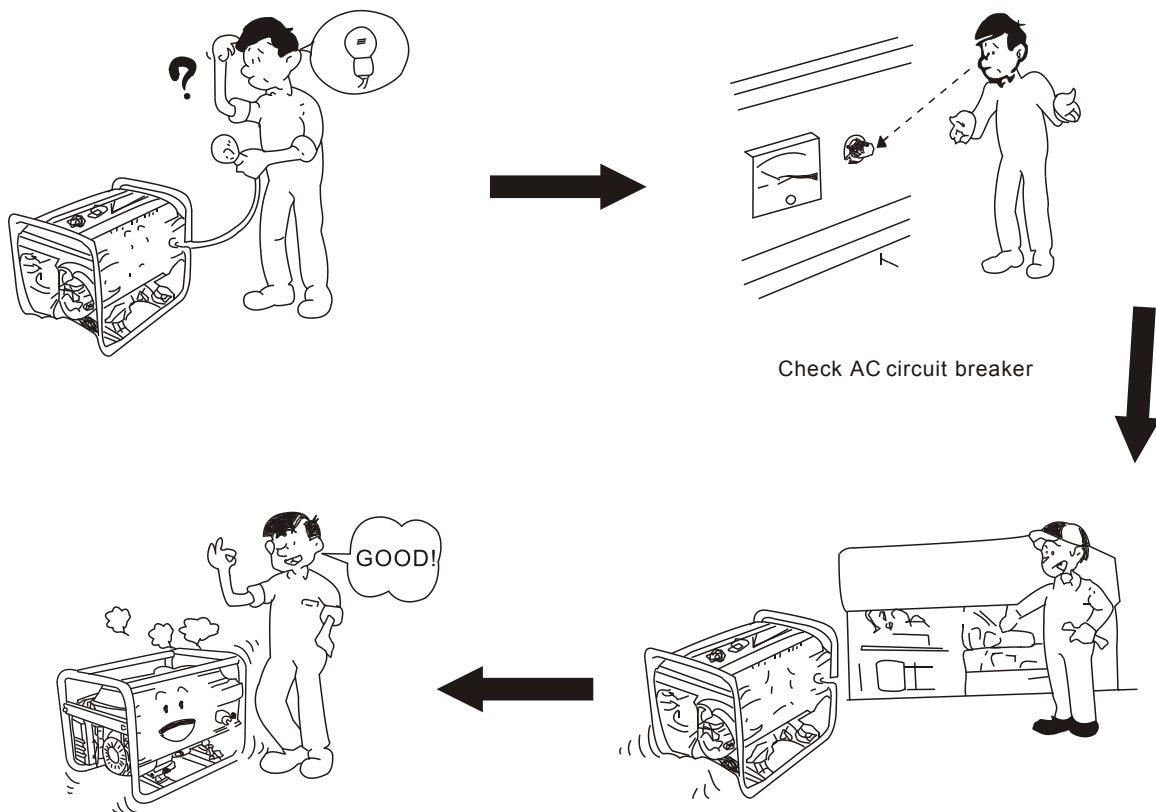

Warranty and Service Questions ?
Missing or Damaged parts
Call 866 797 2738

In case long term storage generator has no output when started, please disconnect all appliances and prod the ARM to increase the throttle until the volt-meter indicates voltage

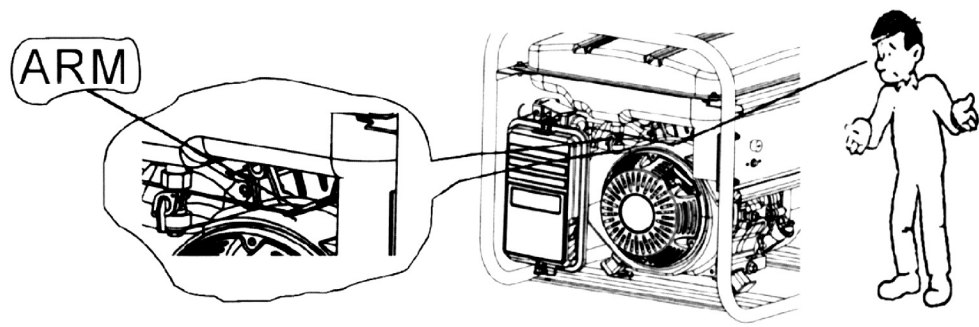

10.WIRING DIAGRAM

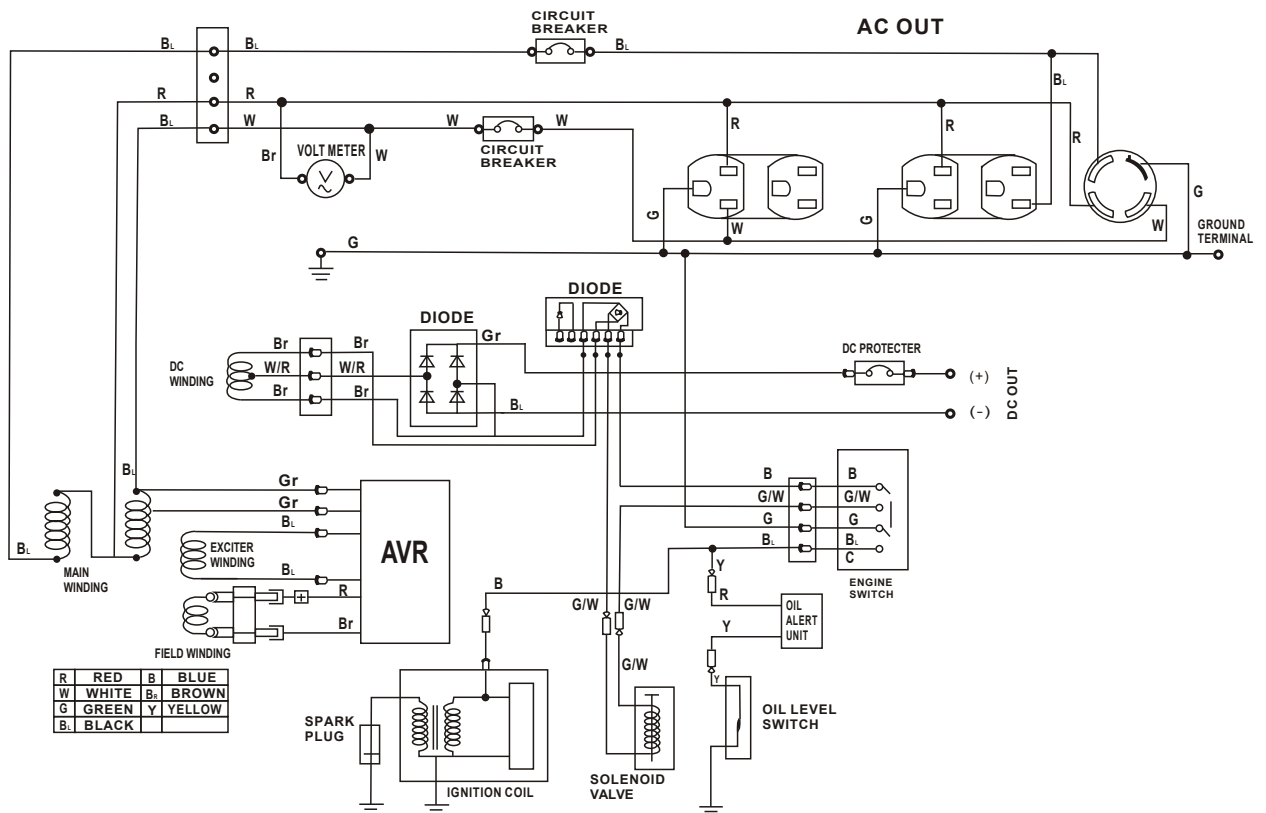

Warranty and Service Questions ?
Missing or Damaged parts
Call 866 797 2738

11.SPECIFICATIONS

Package(LxWxH)(in)	32.1×21.26×22.05(815×540×560mm)
Net weight(lbs)	178.6(81kg)
Model	GG5500
Type	Single phase, AVR
Rated voltage(V)	120/240
Rated frequency(Hz)	60
Rated current(A)	41.67/20.83
Rated power(kW)	5.0
Max.power(kW)	5.5
Power factor(cos(ϕ))	1.0
DC rated voltage(V)	12
DC rated current(A)	10
Safety device	N.F.B
Engine	JF182FPH-2A
Type	Air-cppled single cylinder.4-stroke engine
Bore x stroke (in)	3.23×2.52(82mm×64mm)
Output MAX.(Hp/rpm)	11/3600(8.1KW/3600r.p.m)
Start mode	Recoil start
Operation time(hr)	9
Ignition system	TCI
Fuel type	Unleaded gasoline
Oil type	SAE 10W-30/SAE 10W-40

Note: specifications subject to change without prior notice.

Warranty and Service Questions ?
 Missing or Damaged parts
 Call 866 797 2738

12.WHEEL KIT

- 1.Install the two wheels on the generator using two bolts .
- 2.Install the crutches on the under frame.
- 2.Install the handrails on the right frame.

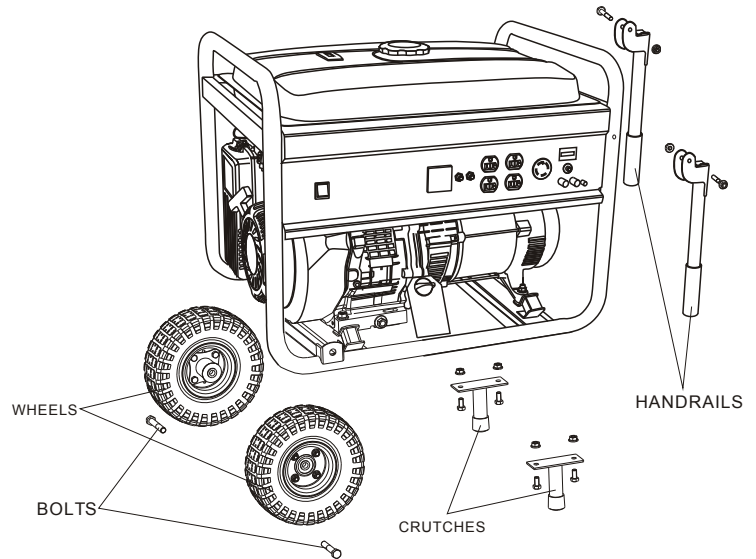

13.PARTS LIST AND DIAGRAM

13.1 CRANKCASE ASSY

NO.	PARTS NO.	DESCRIPTION	QTY
1	QJ182QDP.01-11	Buse, locating	2
2	157.5-10	SPACER, drain	2
3	157.5-9	BOLT, drain	2
4	QJ150FMG.5-8	DOWEL PIN	2
5	GB5787-86	BOLT M6×12	4
6	QJ182QDP.01.04	Sensor Assy, Fuel level	1
7	157-1-6-13	NUT	1
8	QJ182QDP.01-01	COVER, CRANKCASE	1
9	QJ168QDJ.01-05	SEAL WASHER	2
10	QJ168QDJ.01-03	PLUG, ADD OIL	1
11	GB5787-86	BOLT M8×40	7
12	QJ182QDP.01.01	OIL SEAL 52×34×8	2
13	QJ168QDJ.01-04	OIL LEVEL STICK	1
14	QJ182QDP.01-03	SPACER, CRANKCASE	1
15	GB/T276-94	Bearing6202 15×35×11	2
16	GB/T276-94	Bearing6207 35×72×17	1
17	QJ182QDP.01-10	Pin	1
18	QJ182QDP.01-05	ELECTRONIC SWITCH	1
19	QJ182QDP.01-09	CLIP, Cord	1
20	QJ182QDP.01-08	SEAL GASKET, rubber	1
21	GB5787-86	BOLT M6×25	2
22	QJ182QDP.01.03	OIL SEAL	1
23	QJ182QDP.01.02	CRANKCASE ASSY	1

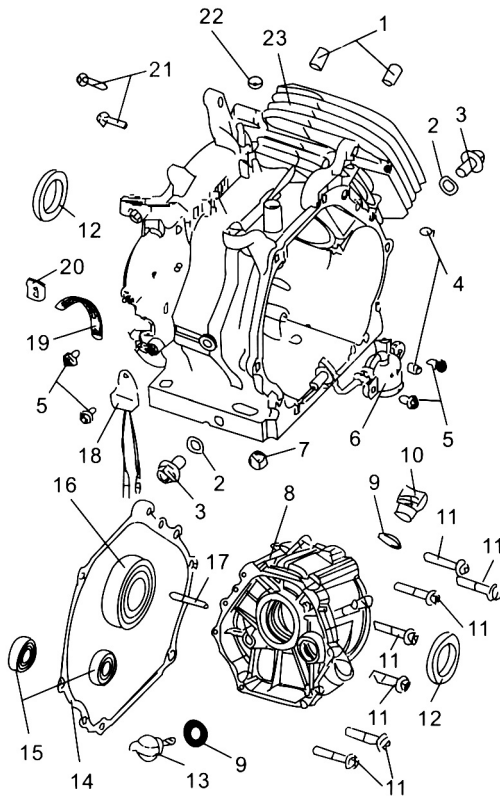

Warranty and Service Questions ?
 Missing or Damaged parts
 Call 866 797 2738

13.2 CYLINDER HEAD ASSY

NO.	PARTS NO.	DESCRIPTION	QTY
1	QJ182QDP.02.01	Cylinder Head Assy	1
2	QJ182QDP.02-01	Bolt, Cylinder Head	4
3	QJ182QDP.02.02	Cover Assy	1
4	QJ182QDP.02-03	Spacer, Seal	1
5	QJ182QDP.02-04	Clamp	1
6	QJ182QDP.02-02	Bolt	1
7	QJ182QDP.02.03	Spacer Assy	1
8	QJ182QDP.02-05	Bolt, Intake Pipe	2
9	QJ182QDP.02-06	Cowling	1
10	GB5787-88	Bolt M6×12	1
11	QJ182QDP.02-07	Spacer, Intake Pipe	1
12	QJ182QDP.02.04	Spark Plug(NGK-BPR6ES)	1
13	QJ182QDP.02.02-02	Washer	1
14	QJ182QDP.02.01-05	Canal, Intake Valve	1
15	QJ182QDP.02.01-03	Canal, Exhaust Valve	1
16	QJ182QDP.02.01-04	Ring, Exhaust Valve	1
17	QJ182QDP.02.01-04	Ring, Intake Valve	1
18	GB/T6177-2000	Nut M6	2

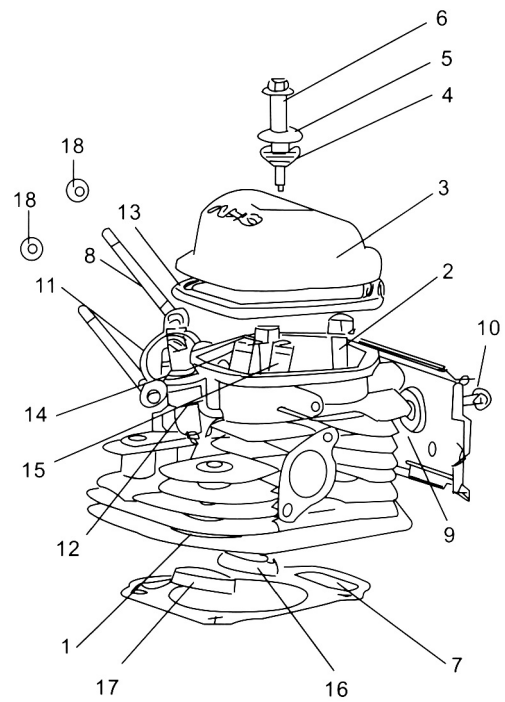

Warranty and Service Questions ?
 Missing or Damaged parts
 Call 866 797 2738

13.3 CAMSHAFT ASSY

NO.	PARTS NO.	DESCRIPTION	QTY
1	QJ182QDP.03-12	Exhaust valve	1
2	QJ182QDP.03-11	Lower retainer	1
3	QJ182QDP.03-05	Valve spring	2
4	QJ182QDP.03-08	Exhaust valve spring retainer	1
5	QJ182QDP.03-09	Valve rotator	1
6	QJ182QDP.03-04	Pivot bolt	2
7	QJ182QDP.03-06	Valve rocker arm	2
8	QJ182QDP.03-07	Rocker arm pivot	2
9	QJ182QDP.03-11	Pivot adjusting nut	2
10	QJ182QDP.03-10	Intake valve spring retainer	1
11	QJ182QDP.03.02	Push rod	2
12	QJ182QDP.03-03	Push rod guide plate	1
13	QJ182QDP.03-13	Intake valve	1
14	QJ182QDP.03-01	Valve lifter	2
15	QJ182QDP.03.01-06	Spring	1
16	QJ182QDP.03.01-02	Pin I	1
17	QJ182QDP.03.01.01-01	Fly clump I	1
18	QJ182QDP.03.01.01-02	Fly clump II	1
19	QJ182QDP.03.01.01-03	Pin IV	2
20	QJ182QDP.03.01-03	Pin II	1
21	QJ182QDP.03.01-01	Camshaft	1
22	QJ182QDP.03.01-04	Decompress clump	1
23	QJ182QDP.03.01-05	Pin III	1
24	QJ182QDP.03.01	Camshaft comp.	1

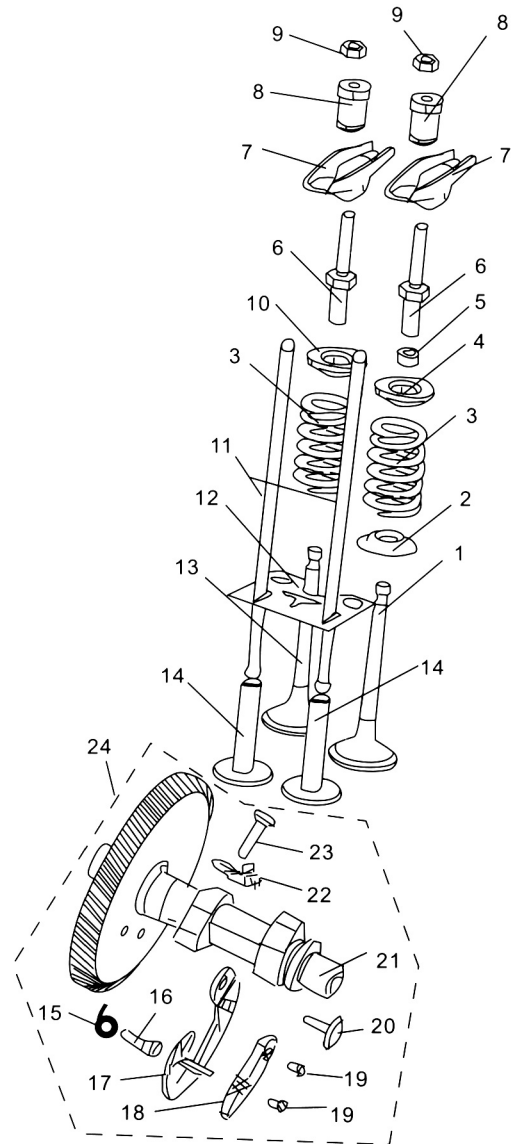

13.4 CRANKSHAFT ASSY

NO.	PARTS NO.	DESCRIPTION	QTY
1	QJ182QDP.04-01	BALANCE SHAFT	1
2	QJ182QDP.04-02	NUT	1
3	QJ182QDP.04-03	WOODRUFF KEY	1
4	QJ182QDP.04-04	CRANKSHAFT(1-type)	1
5	QJ182QDP.04-05	CRANKSHAFT GEAR I	1
6	QJ182QDP.04-06	CRANKSHAFT GEAR II	1
7	GB/T276-94	Bearing6207	1

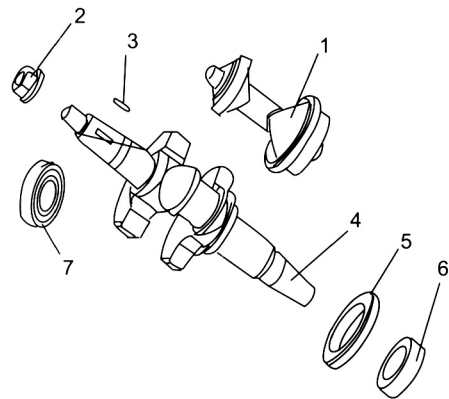

Warranty and Service Questions ?
Missing or Damaged parts
Call 866 797 2738

13.5 CRANKSHAFT ASSY & PISTON

NO.	PARTS NO.	DESCRIPTION	QTY
1	QJ182QDP.05-01	PISTON	1
2	QJ182QDP.05-02	RING 1ST	1
3	QJ182QDP.05-03	RING 2ND	1
4	QJ182QDP.05.01	RING SET OIL	1
5	QJ182QDP.05-04	PIN, PISTON	1
6	QJ182QDP.05-05	CIRCLIP	2
7	QJ182QDP.05.02	CONNECTING ROD ASSY	1
8	QJ182QDP.05-02-01	CONNECTING ROD	1
9	QJ182QDP.05-02-02	CONNECTING ROD CAP	1
10	QJ182QDP.05-02-03	CONNECTING ROD BOLT	2

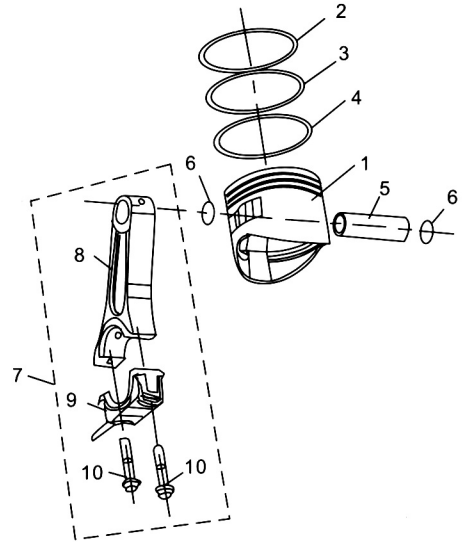

13.6 CENTRIFUGAL TIMING IMPLEMENT ASSY

NO.	PARTS NO.	DESCRIPTION	QTY
1	QJ182QDP.06-09	Pull Pole, steel wire	1
2	QJ182QDP.06-10	Pull spring, little	1
3	QJ182QDP.06-01	Pull Ploe, Timing implement	1
4	QJ182QDP.06-08	Pull spring, big	1
5	GB6177-2000	Nut M6	1
6	QJ182QDP.06-05	Washer I	1
7	QJ182QDP.06-04	Fork	1
8	QJ182QDP.06-01-03	Governor weight	3
9	QJ182QDP.06-01-02	Governor weight pin	3
10	QJ166QDK.06-07	Washer III	1
11	QJ182QDP.06.01-01	Centrifugal Timing Implement	1
12	QJ166QDK.01-02	Clip	1
13	QJ182QDP.06-07	Washer II	1
14	QJ182QDP.06-06	Handspike Cover	1
15	QJ182QDP.06-02	Clip	1
16	QJ182QDP.06-03	Bolt, Square Toes	1

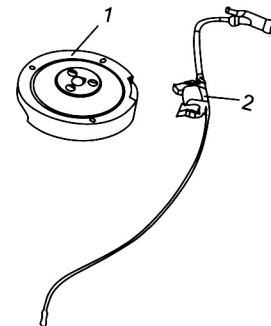
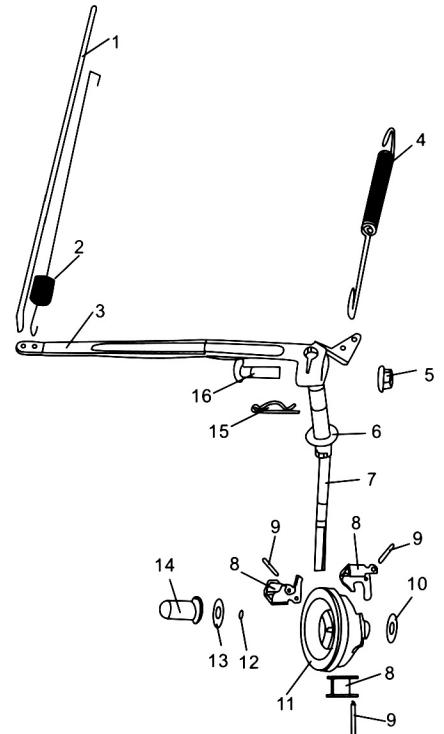

13.7 INFLAME ASSY

NO.	PART NO.	DESCRIPTION	QTY
1	QJ182QDP.07.02	ROTOR ASSY	1
2	QJ182QDP.07.01	high voltage wrap	1

Warranty and Service Questions ?
Missing or Damaged parts
Call 866 797 2738

13.8 STARTER ASSY

NO.	PARTS NO.	DESCRIPTION	QTY
1	QJ182QDP.08.01-10	Handle	1
2	QJ182QDP.08.01-11	Pull Rope	1
3	QJ182QDP.08.01-09	Clockwork Spring	1
4	QJ182QDP.08.01-03	Rotary Table	1
5	QJ182QDP.08.01-05	Spring, Return	2
6	QJ182QDP.08.01-07	Screw	1
7	GB5789-86	Bolt M6x12	5
8	QJ182QDP.08-01	Starter Canister	1
9	QJ182QDP.08-02	Fan Wheel	1
10	QJ182QDP.08.01-01	Cowling Assy, cylinder	1
11	QJ182QDP.08.01-08	Guide Pan	1
12	QJ182QDP.08.01-04	Clump	2
13	QJ182QDP.08.01-06	Press Reed	1
14	QJ182QDP.08.01-02	Washer	1
15	QJ182QDP.08.01.01	Starter Cover Assy	1
16	GB5789-86	Bolt	3
17	QJ168FJH-3.08.01	Switch	1
18	QJ182QDP.08.01	Starter Assy	1

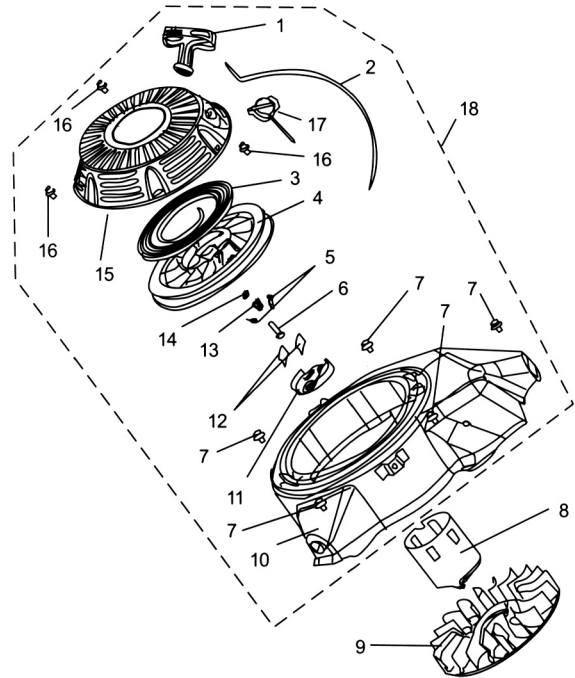

13.9 ENGINE SPROCKET COVER

NO.	PARTS NO.	DESCRIPTION	QTY
1	QJ182QDP.09	Speed djustment base assembly	1
2	QJ168QDJ.05.01-02	Spring	1
3	GB818-2000	ScrewM5x35	1

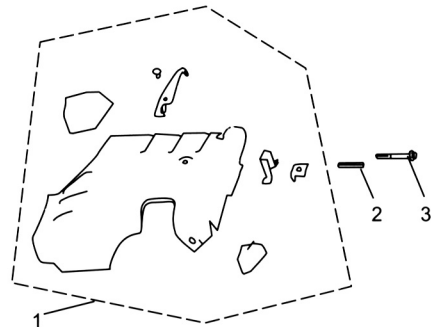

13.10 CARBURETOR ASSY

NO.	PARTS NO.	DESCRIPTION	QTY
1	QJ182QDP.10.01	Carburator Assy	1
2	QJ182QDP.10-01	Carburetor packing	1
3	QJ153FM-0000041	Clip	1
4	QJ182QDP.10-02	Hose ϕ 4.5x ϕ 8.5x210	1
5	QJ182QDP.10-03	Hose ϕ 9x ϕ 12x150	1

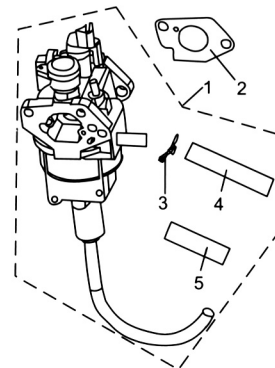

Warranty and Service Questions ?
 Missing or Damaged parts
 Call 866 797 2738

13.11 CARBURETOR ASSY

NO.	PARTS NO.	DESCRIPTION	QTY
1	QJ182QDP.11	Air Cleaner Assy	1
2	QJ182QDP.11-6	Clip, Fixup I	2
3	QJ182QDP.11-7	Clip, Fixup II	2
4	QJ182QDP./11-8	Air Cleaner Cover	1
5	GB6177-2000	NUT M5	6
6	QJ182QDP.11-9	Core, Filtrate	1
7	QJ182QDP.11-3	Hole Board	1
8	QJ182QDP.11-4	Seal Gasket,	1
9	QJ182QDP.11-5	Below Shell, Air Cleaner	1
10	QJ182QDP.11-2	Air Cleaner	1
11	GB6177-2000	NUT M6	1

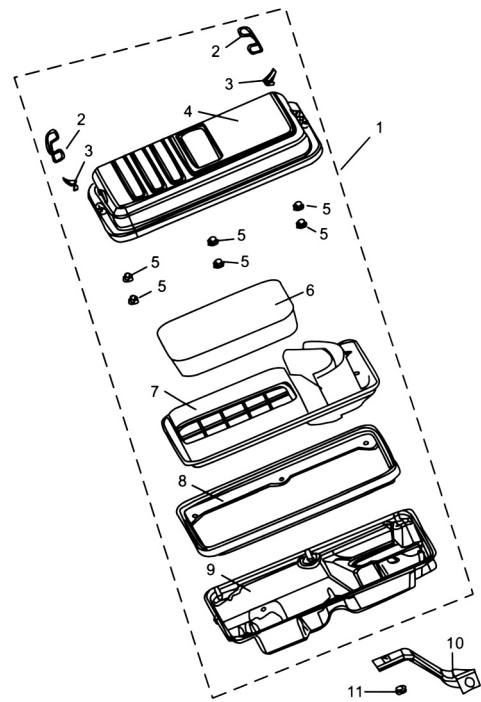

13.12 CARBURETOR ASSY

NO.	PARTS NO.	DESCRIPTION	QTY
1	QJ182QDP.02.02-03	Breath Tube	1
2	QJ182QDP.02.02-04	Rubber galosh	1
3	QJ182QDP.10.02	Choke vavle variable pump comp.	1
4	QJ182QDP.10.02-03	Clip	1
5	QJ182QDP.10.02.01-01	Clip	4
6	QJ182QDP.10.02.01-02	Hose $\phi 4 \times \phi 8 \times 135$	2
7	QJ182QDP.10.02.01.01	Valve	1
8	QJ182QDP.02-08	Bakelite Washer	1
9	QJ182QDP.10.02-04	Rubber galosh I	1
10	QJ182QDP.10.02.01	Valve Assy	1
11	QJ182QDP.10.02-01	Choke vavle Pull pole	1
12	QJ182QDP.10.02-02	Rubber galosh II	1
13	QJ182QDP.10.02.02	Breath body Assy	1
14	QJ182QDP.11-1	Air cleaner Packing	2
15	QJ182FPH-2.07-01	Pull pole	1

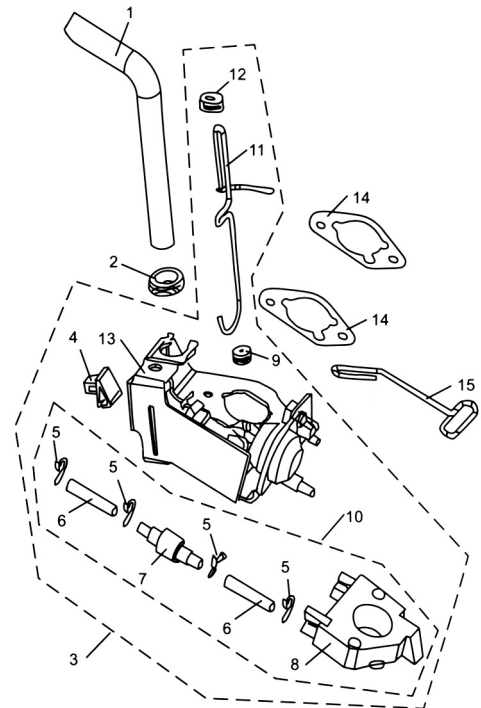

Warranty and Service Questions ?
 Missing or Damaged parts
 Call 866 797 2738

13.13 GENERATOR

NO.	CODE	DESCRIPTION	QTY
1	GB/T5787-86	Bolt M5*12	7
2	QJ6500.03-04	Right Cover	1
3	QJ6000.03.04	AVR	1
4	GB/T5789-86	Bolt M5*20	3
5	QJ6500.03-03	Connector	1
6	GB/T5789-86	Bolt M5*12	1
7	QJ6500.03.03	Rectifier	1
8	GB/T5789-86	Bolt M10*250*1.25	1
9	QJ6000.03.01	Brush Equipment	1
10	QJ6000.03-02	Motor Shell	1
11	QJ6500.03.01	Rotor Assy	1
12	QJ6500.03-06	Motor cover	1
13	QJ6000.03.03.01	BEARING, needle	1
14	QJ6000.03.03-06	Carbon Brush Ring	1
15	QJ6000.03.03	Stator	1
16	QJ6000.03.03-01	Impeller	1
17	GB/T95-85	Washer	3
18	GB/T93-87	Spring Washer	3
19	GB/T818-85	Bolt M5*12	3

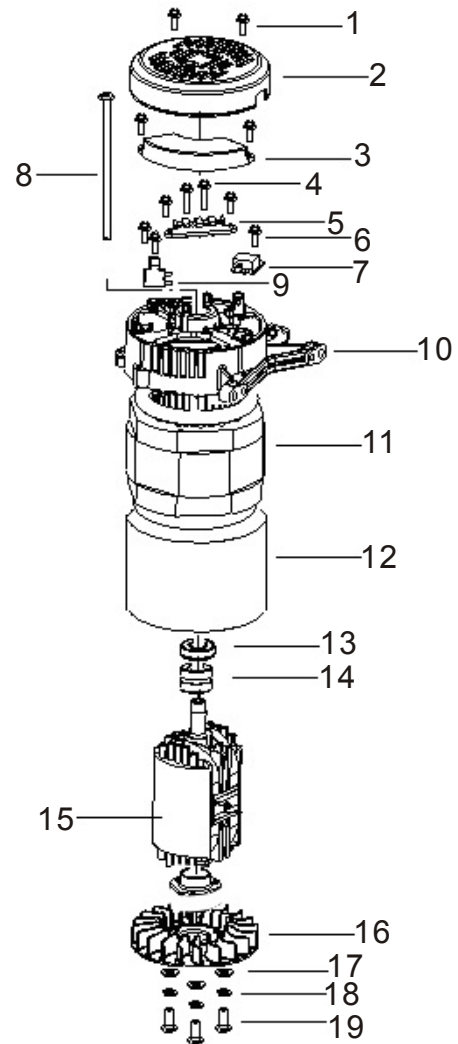

13.14 GAS TANK ASSEMBLY

NO.	CODE	DESCRIPTION	QTY
1	QJ6500.01.01	Fuel Tank Comp	1
2	QJ950.13-02	Filtering Net	1
3	QJ3000.01.04	Sump Cover Subassembly	4
4	GB/T819-85	Screw M5*10	2
5	QJ3000.01.03	Sender Unit	1
6	GB/T5787-86	Bolt M6*20	4
7	GB/T95-86	Washer	4
8	QJ2600.01-02	Fuel Tank Rubber Hose	4
9	QJ2600.01-01	Fuel Tank Rubber	4
10	QJ6500.01.02	Fuel Valve	1

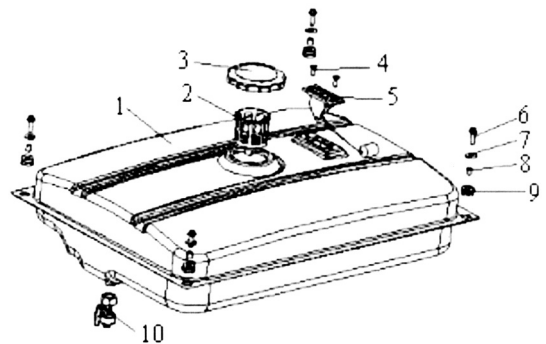

Warranty and Service Questions ?
 Missing or Damaged parts
 Call 866 797 2738

13.15 PANEL ASSY

NO.	CODE	DESCRIPTION	QTY.
1	QJ6500.02.02	Engine Switch	1
2	QJ6500D.01.01	Panel	1
3	QJ6500D.01-01	Bottom Shell	1
4	QJ6500.02.07	Carburetor Controller	1
5	QJ6500.02.03	Circuit Breaker	2
6	QJ3200.01.02	3-Pole Socket for USA	2
7	GB/T6177-86	Nut M4	7
8	QJ6500D.01.03	4-Pole Socket	1
9	QJ6500.02.04	DC Protector	1
10	QJ6500D.01.04	Hour Meter	1
11	GB/T5787-86	Bolt M6*16	4
12	GB/T6170-86	Nut M6	2
13	GB/T923-88	Nut M6	1
14	QJ6500.02.05	DC Terminal	2
15	GB/T818-85	Screw M4*12	7
16	GB/T818-85	Screw M3*4	4
17	QJ2600.02.05A	Voltmeter	1

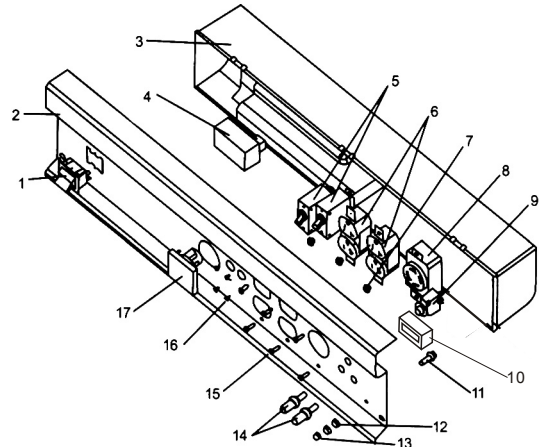

13.16 MUFFLER ASSY

MUFFLER ASSY

NO.	CODE	DESCRIPTION	QTY.
1	QJ6500.07.01	Muffler	1
2	QJ6800.05-01	Muffler Cover	1
3	GB/T6177.1-2000	Nut M6	2
4	GB/T818-2000	Screw M6*25	2
5	QJ3500.05.03	Gulp Valve	1

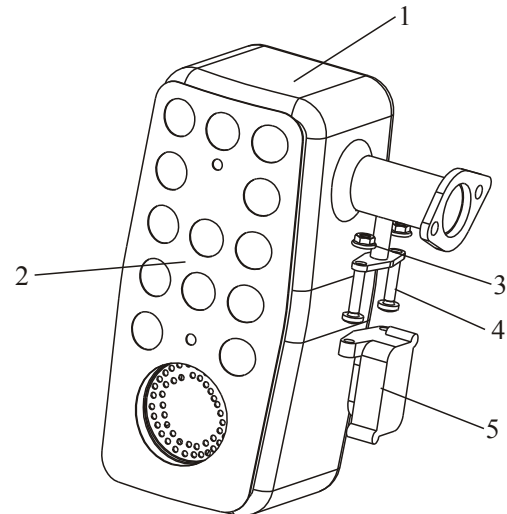

Warranty and Service Questions ?
 Missing or Damaged parts
 Call 866 797 2738

13.17 FRAME ASSY

NO.	CODE	DESCRIPTION	QTY.
1	QJ6500D.04-06	Wheel Axis Bolt	2
2	QJ6500D.04-02	Wheel 4.10/3.5	2
3	QJ6500D.04-01A	Frame Jointing Assy	1
4	GB/T6177.1-2000	Nut M10*1.25	4
5	QJ6000.08-02	Shockproof Big Mounting Feet	2
6	QJ6000.08-03	Shockproof Small Mounting Feet	2
7	GB/T6177.1-2000	Nut M6	2
8	GB/T5789-86	Bolt M6*40	2
9	QJ6500D.04-01A	Handrail	2
10	QJ6500.04-02	Handrail Jacket	2
11	GB/T6177-2000	Nut M8	10
12	GB/T5780-2000	Bolt M8*16	4
13	QJ6500D.04-03A	Crutch	2
14	QJ6800.06-02	Crutch Jacket	2

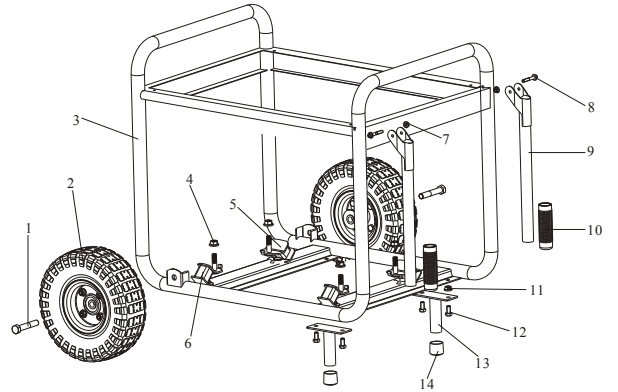

13.18 MOTOR SHIELD ASSY

NO.	CODE	DESCRIPTION	QTY.
1	QJ6500.03-05	Motor shield	1

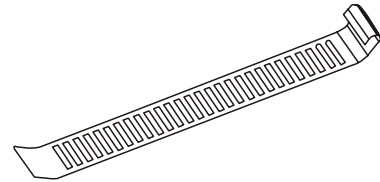

Warranty and Service Questions ?
 Missing or Damaged parts
 Call 866 797 2738

14. Parts Replacement Limited Warranty

IMS-UST warrants to the original purchaser that the mechanical and electrical components will be free of defects in material and workmanship for a period of one (1) year or 60 hours from the original date of purchase (whichever is first). For commercial and industrial use, the warranty is applicable for 90 days or 60 hours, whichever comes first. All costs associated with the transportation, diagnosis and replacement of parts determined to be not operable during this warranty period are the sole responsibility of the purchaser. This warranty only applies to the original purchaser and is not transferable. No claims for warranties will be processed without valid proof of purchase.

For Help with Your Warranty

Do not return the unit to the place of purchase

Contact IMS-UST's Technical Service and IMS-UST will troubleshoot your problems with this product via phone or e-mail. If the problem is not corrected as a result of the phone or email contact, IMS-UST at its option will evaluate the issue and will authorize a repair or replacement of the defective

part of the unit. IMS-UST will provide you with a case number for warranty service. IT IS THE RESPONSIBILITY OF THE PURCHASER TO ARRANGE AND PREPAY ALL TRANSPORTATION CHARGES. NO UNITS SENT TO IMS-UST WILL BE RECEIVED AT IMS-UST WITHOUT A VALID CASE NUMBER INCLUDED ON THE SHIPPING LABEL. No exceptions to this warranty procedure are allowed. Failure to follow the steps outlined (phone consult, return authorization, pre-paid freight return) will result in no parts replaced under the warranty.

What is not covered by this Warranty

- Normal Wear and Tear
- Problems caused by using dirty or otherwise contaminated fuel.
- Problems caused by not properly maintaining the correct crankcase oil type and fluid level. This unit is equipped with a low oil auto shutoff sensor. Maintaining proper oil volume in the crankcase is critical to the safe and effective use of the motor.
- Generators need periodic parts and service to perform well. This warranty does not cover repair when normal use has exhausted the life of a part or the equipment as a whole.
- This unit is powered by an air cooled engine. Operating this unit in environments where the air temperature and relative humidity are extreme will cause parts to malfunction. This warranty does not cover those situations.
- This warranty will not apply to parts if this generator is deemed to have been misused, neglected, involved in an accident, abused, loaded beyond the generator's limits, modified, installed improperly or connected incorrectly to any electrical component. Normal maintenance such as air filters, adjustments, fuel system cleaning, spark plugs and obstruction due to contaminant buildup are not covered by this warranty.

Limits of Implied Warranty and Consequential Damage – issues specifically not covered under the warranty.

- Cosmetic defects.
- Failures due to acts of God and other forces of natural events beyond the manufacturer's control.
- Problems caused by parts that are not original OEM parts.
- This warranty will not cover any damages that occur from the user's failure to follow the instructions and warnings provided in the manual.
- IMS-UST disclaims any obligation to cover any loss of time, use of this product, freight, or any incidental or consequential claim by anyone from using this generator
- Parts provided as a replacement will be subject to the warranty of the original unit. The length of the warranty will never exceed the total time period of the warranty from the original purchase date.

THERE IS NO OTHER EXPRESS WARRANTY. ALL IMPLIED WARRANTIES ARE EXCLUDED UNLESS PROVIDED BY AN INDEPENDENT RETAILER IN WHICH CASE ANY IMPLIED WARRANTIES ARE THE RESPONSIBILITY OF THE RETAILERS WHO EXTENDED THEM. LIABILITY FOR INCIDENTAL OR CONSEQUENTIAL DAMAGES ARE EXCLUDED TO THE EXTENT EXCLUSION IS PERMITTED BY LAW. This warranty gives you certain legal rights which may change from state to state. Your state may also have other rights you may be entitled to that are not listed within this warranty.

Warranty and Service Questions ?
Missing or Damaged parts
Call 866 797 2738



PRODUCT REGISTRATION CARD

For more efficient customer service, please fill out the information below and mail to International Merchandising Service, Inc

Model No. _____ Engine Serial No. _____ Purchase Date ____/____/____

Purchased from: Retail location Private Consumer Other _____

Name: _____

Location Address: _____

Telephone w/ area code: _____ Purchase Price: _____

Purchased: NEW or USED

Consumer Information:

Name _____ Telephone w/ area code: _____

Street Address: _____ Suite or Apt No. _____

City: _____ State _____ Zip Code _____

Province or Country _____

Are you a: Business or Residence

Product usage Information:

How often will you use this product? Everyday Periodically Emergency use only
 Other _____

What type of application will you use this product in?

Heavy Commercial Moderate Commercial Light Commercial Tradeshows
 Heavy Residential Moderate Residential Light Residential Camping, backpacking
 Other _____

Mail this page to: International Mer Service, Inc,
1928 West Malvern Avenue
Fullerton, CA 92833

Warranty and Service Questions ?
Missing or Damaged parts
Call 866 797 2738