



AD-81 Parts Manual 24 VAC Phase 5 2001-2002



800-462-4814

American Dryer Corporation
88 Currant Road
Fall River, MA 02720-4781
Telephone: (508) 678-9000 / Fax: (508) 678-9447
E-mail: techsupport@amdry.com
www.amdry.com

Retain This Manual In A Safe Place For Future Reference

American Dryer Corporation products embody advanced concepts in engineering, design, and safety. If this product is properly maintained, it will provide many years of safe, efficient, and trouble-free operation.

ONLY qualified technicians should service this equipment.

OBSERVE ALL SAFETY PRECAUTIONS displayed on the equipment or specified in the installation manual included with the dryer.

The following “**FOR YOUR SAFETY**” caution **must be** posted near the dryer in a prominent location.

FOR YOUR SAFETY

Do not store or use gasoline or other flammable vapors and liquids in the vicinity of this or any other appliance.

POUR VOTRE SÉCURITÉ

Ne pas entreposer ni utiliser d'essence ni d'autres vapeurs ou liquides inflammables à proximité de cet appareil ou de tout autre appareil.

We have tried to make this manual as complete as possible and hope you will find it useful. **ADC** reserves the right to make changes from time to time, without notice or obligation, in prices, specifications, colors, and material, and to change or discontinue models.

Important

For your convenience, log the following information:

DATE OF PURCHASE _____ **MODEL NO.** AD-81

RESELLER'S NAME _____

Serial Number(s) _____

Replacement parts can be obtained from your reseller or the **ADC** factory. When ordering replacement parts from the factory, you can FAX your order to **ADC** at (508) 678-9447 or telephone your order directly to the **ADC** Parts Department at (508) 678-9000. Please specify the dryer **model number** and **serial number** in addition to the **description** and **part number**, so that your order is processed accurately and promptly.

The illustrations on the following pages may not depict your particular dryer exactly. The illustrations are a composite of the various dryer models. Be sure to check the descriptions of the parts thoroughly before ordering.

“IMPORTANT NOTE TO PURCHASER”

Information **must be** obtained from your local gas supplier on the instructions to be followed if the user smells gas. These instructions **must be** posted in a prominent location near the dryer.

Table of Contents

Hingeless Control Door Assembly	
For Models Mfd. as of July 20, 2002	2
Control Door Assembly	
For Models Mfd. prior to July 20, 2002	3
Phase 5 OPL Microprocessor Control Panel Assembly	4
Phase 5 OPL Microprocessor Control Box Assembly	5
Cold Rolled Steel (CRS) Main Door Assembly	6, 7
Cold Rolled Steel (CRS) Door Front Panel Assembly	8
Main Door Switch Assembly Cold Rolled Steel (CRS) Door	9
Lint Drawer with Cloth Lint Screen/Lint Drawer Switch Assemblies	10
Lint Drawer with Stainless Steel Lint Screen/Lint Drawer Switch Assemblies	11
Sensor Bracket Assembly	12
Basket (Tumbler)/Support Assembly	13
Basket (Tumbler) Bearing Assembly	14, 15
Reversing T.E.F.C. Motor Mount Assembly	16, 17
Burner Assembly II	18, 19
Idler Bearing Assembly	20
Reversing Rear Control Box Assembly	21
Sail Switch Assembly	22
Step Down Transformer Usage Listing	23
Air-Operated Steam Damper Assembly	24, 25
Outer Top/Back Guard Assemblies	26
Additional Parts Available	27

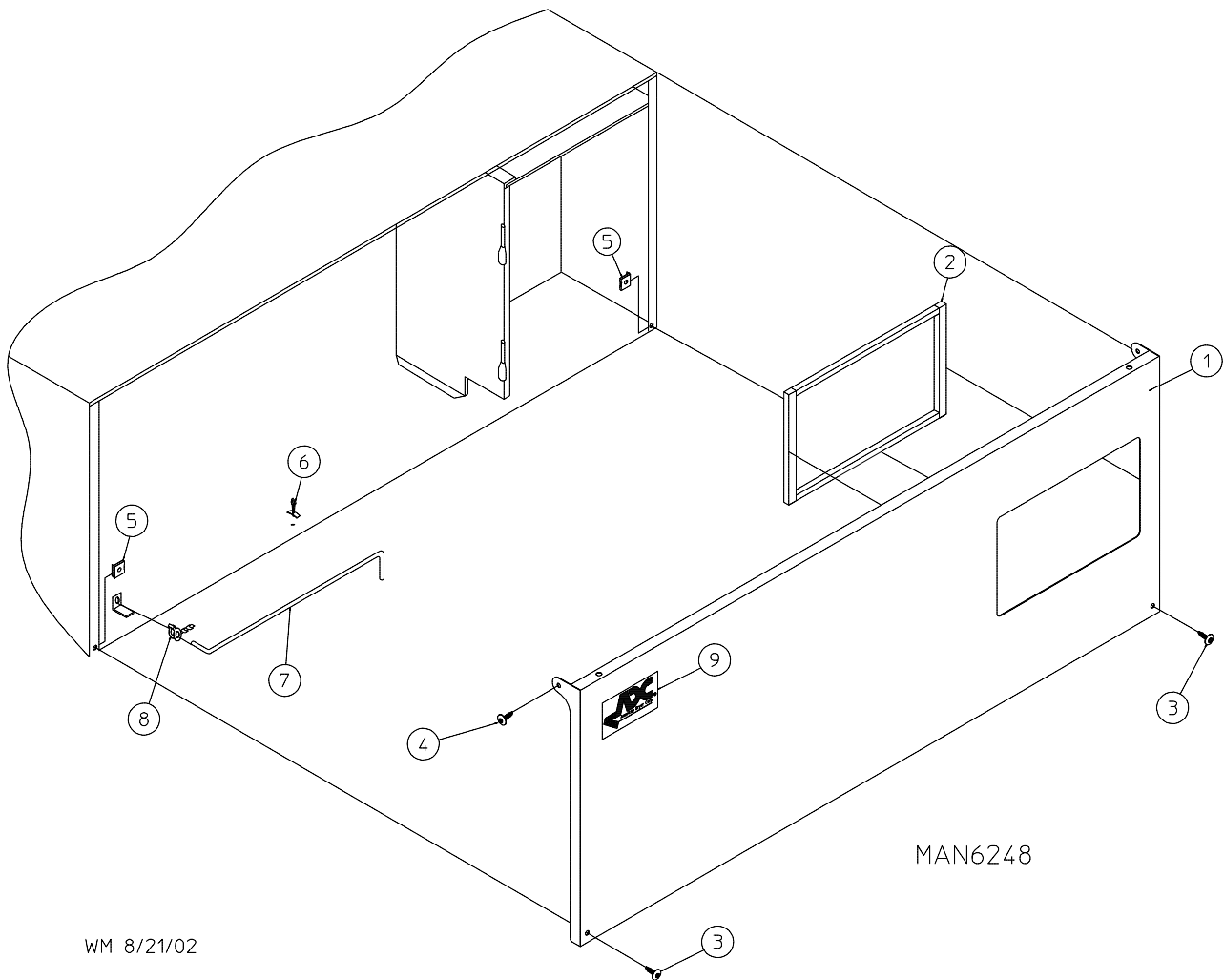

<u>Illus. No.</u>	<u>Part No.</u>	<u>Qty.</u>	<u>Description</u>
1	883491*	1	Control Door Assembly (includes illus. nos. 1 and 2)
	883493	1	Stainless Steel Control Door Assembly (includes illus. nos. 1 and 2)
2	117604	2	Gasket (sold by the foot)
3	150217	2	#10-32 x 3/4" Phillips Pan Head Machine Screw
4	150317	2	#10-16 x 3/4" TORX Plus BTN Type 1 Screw
5	154011	2	#10-32 Multi-Thread U-Nut
6	102603	1	Control Door Rod Catch
7	102502	1	Control Door Support Rod
8	102601	1	Control Door Rod Retainer Clip
9	881053	1	ADC Logo ONLY (with double adhesive tape)
	870011	1	Logo Double Adhesive Tape Kit ONLY

* Specify color when ordering.

For Models Mfd. prior to July 20, 2002

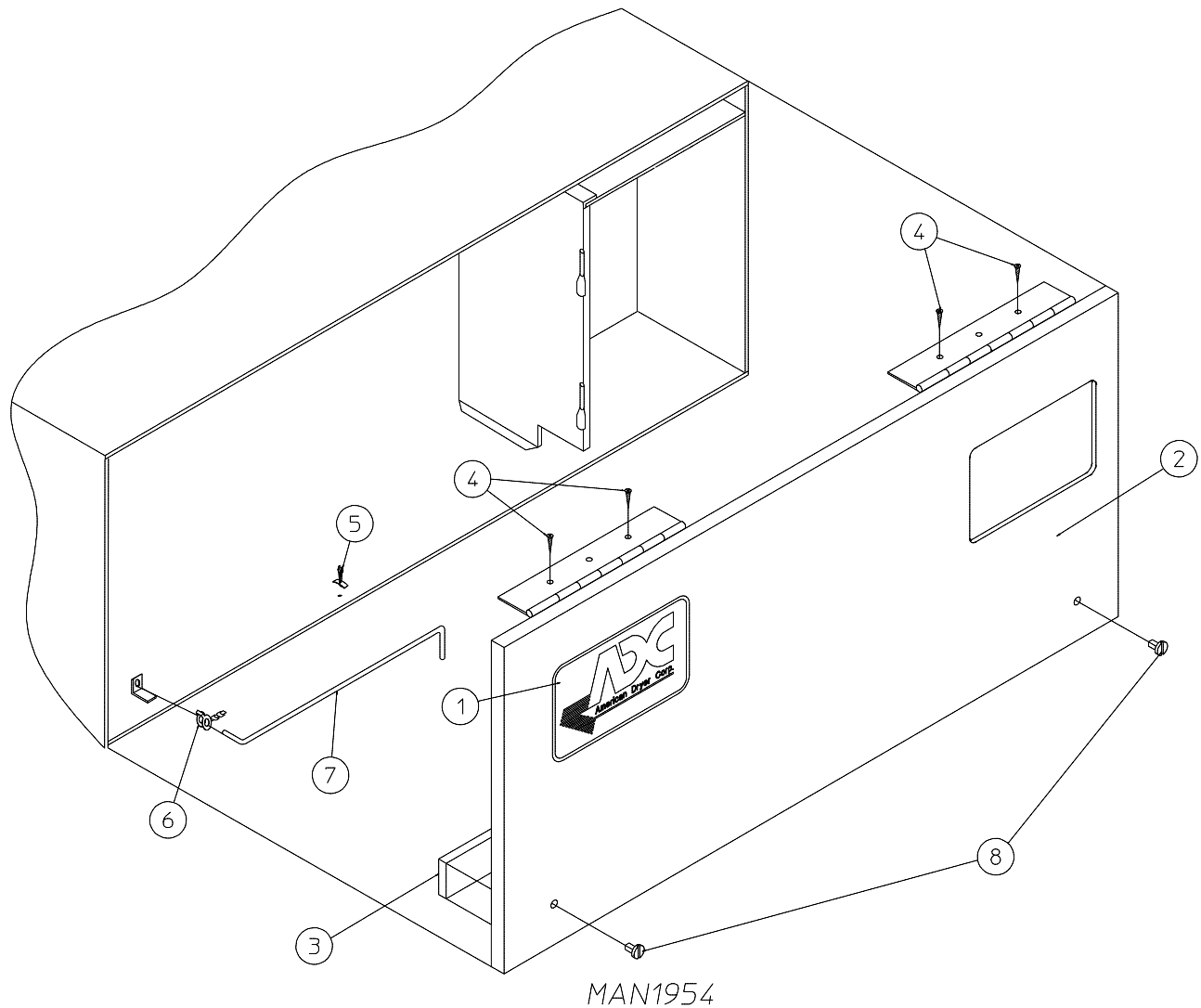

<u>Illus. No.</u>	<u>Part No.</u>	<u>Qty.</u>	<u>Description</u>
1	882052	1	ADC Metal Logo ONLY (with double adhesive tape)
	870011	1	Logo Double Adhesive Tape Kit ONLY
2	881045*	1	Control Door (includes illus. nos. 2 and 3)
	881046	1	Stainless Steel Control Door (includes illus. nos. 2 and 3)
3	117604	4	Neoprene Sponge Tape (sold by the foot)
4	150300	4	#10-16 x 1/2" Hex Washer TEK Screw
5	102600	1	Control Door Rod Support Catch
6	102601	1	Control Door Retainer Clip
7	102502	1	Control Door Rod
8	160005	2	Turn Latch

* Specify color when ordering.

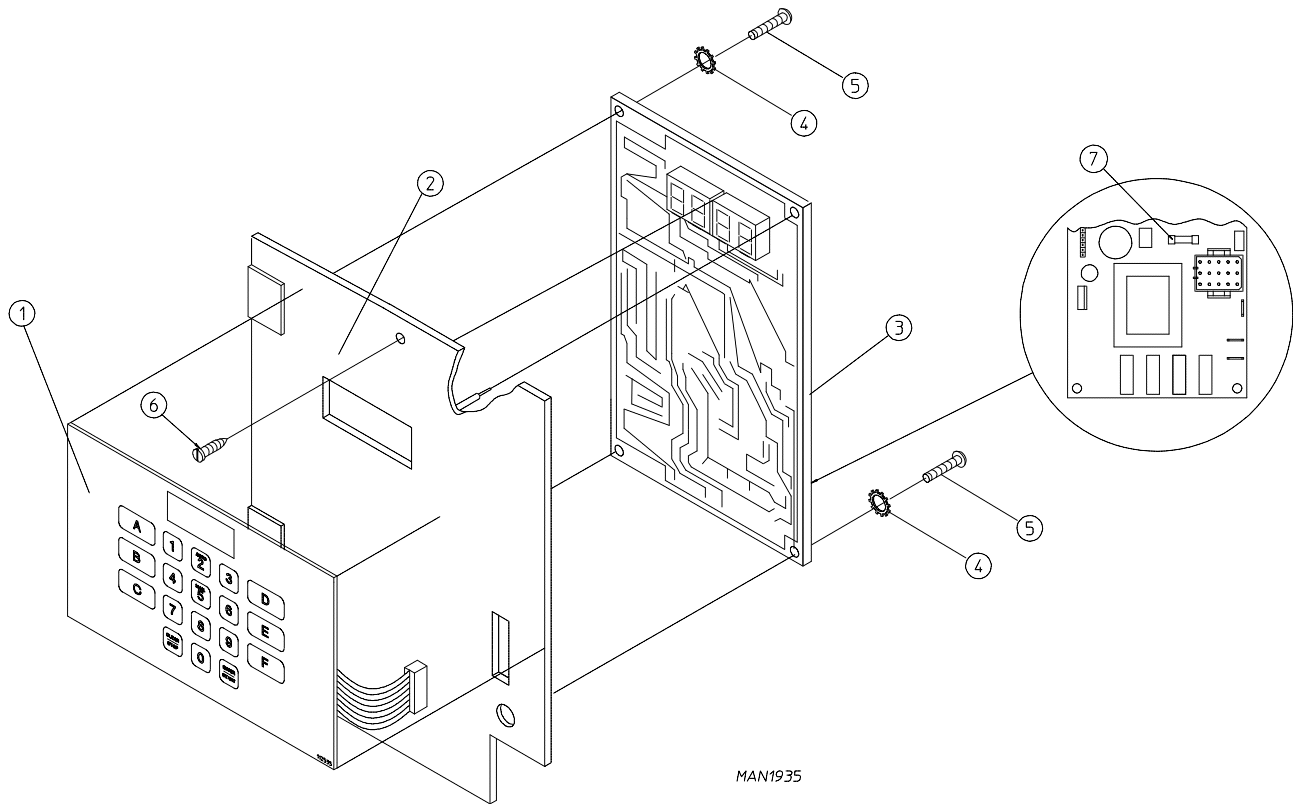

<u>Illus. No.</u>	<u>Part No.</u>	<u>Qty.</u>	<u>Description</u>
1	112535	1	OPL English Keyboard (touch pad) Label Assembly
2	881032	1	Microprocessor Control Panel ONLY
	881033	1	Microprocessor Control Panel ONLY with Battery Bracket
	881034	1	Phase 5 OPL Reversing Microprocessor Control Panel Assembly Complete (includes illus. nos. 1 through 5 and 7)
	881035	1	Phase 5 OPL Reversing Microprocessor Control Panel Assembly with Battery Bracket Clip (includes illus. nos. 1 through 5 and 7)
3	137231	1	Phase 5 OPL Reversing Controller ONLY
4	153010	2	#6 Star Washer
5	150005	2	#6-32 x 3/4" Phillips Round Head Machine Screw
6	150309	1	#10-16 x 1/2" Hex Head CrimpTite Screw
7	136048	1	1/8-Amp (slo blo) Fuse

IMPORTANT: Check label on computer chip to verify correct part number for controller.

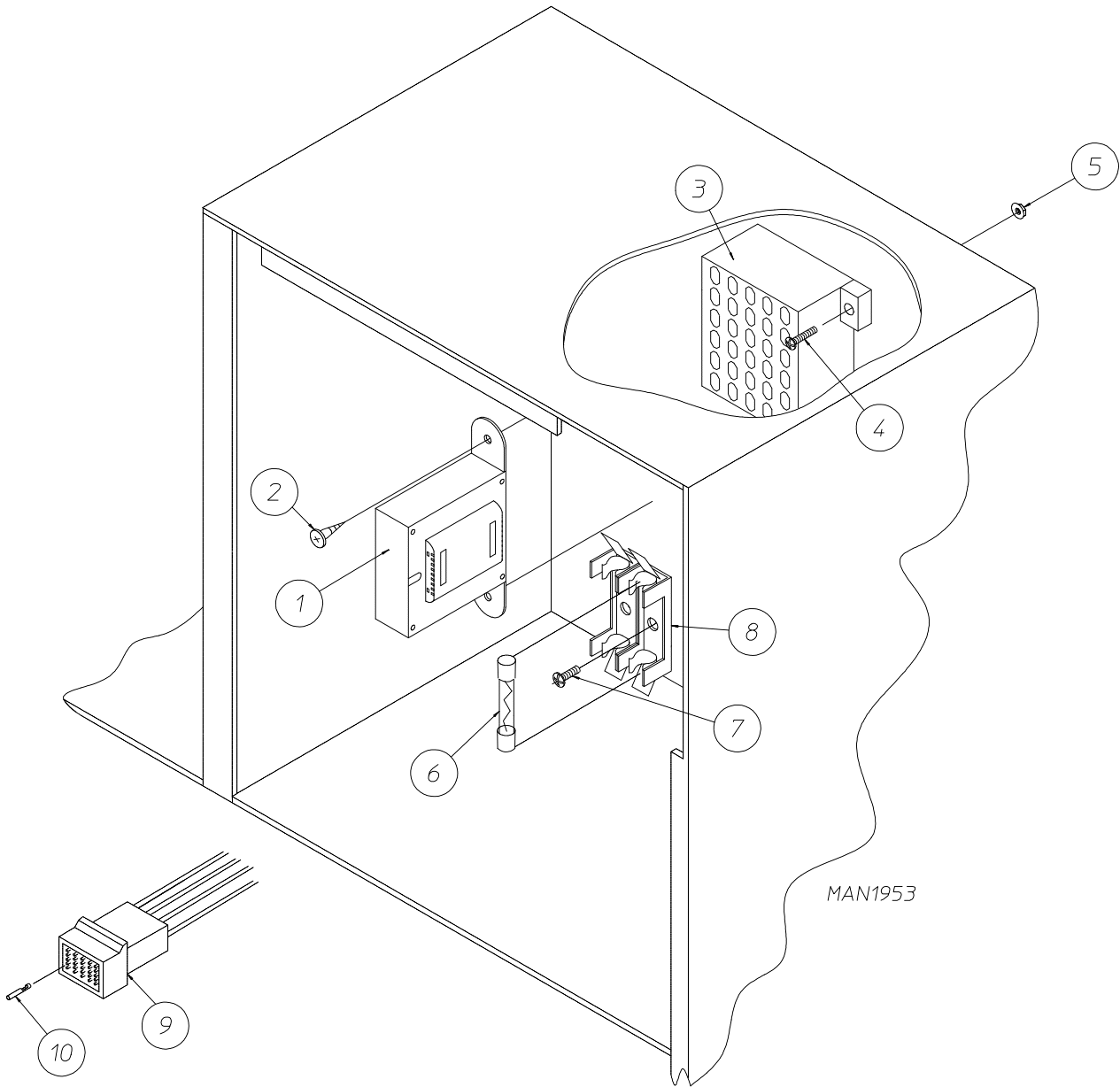

<u>Illus. No.</u>	<u>Part No.</u>	<u>Qty.</u>	<u>Description</u>
1	141403	1	24 VAC Transformer
2	150300	2	#10-16 x 1/2" Hex Washer TEK Screw
3	120715	1	30-Position Terminal Block
4	150002	2	#6-32 x 1" Phillips Round Head Machine Screw
5	151000	2	#6-32 Pal Nut
6	136057	*	1/2-Amp (slo blo) Fuse
7	150301	*	#8-18 x 7/16" Phillips Pan Head TEK Screw
8	136008	*	Fuse Block/Strip ONLY
9	122641	1	15-Pin Microprocessor Connector
10	122706	*	Socket

* As required.

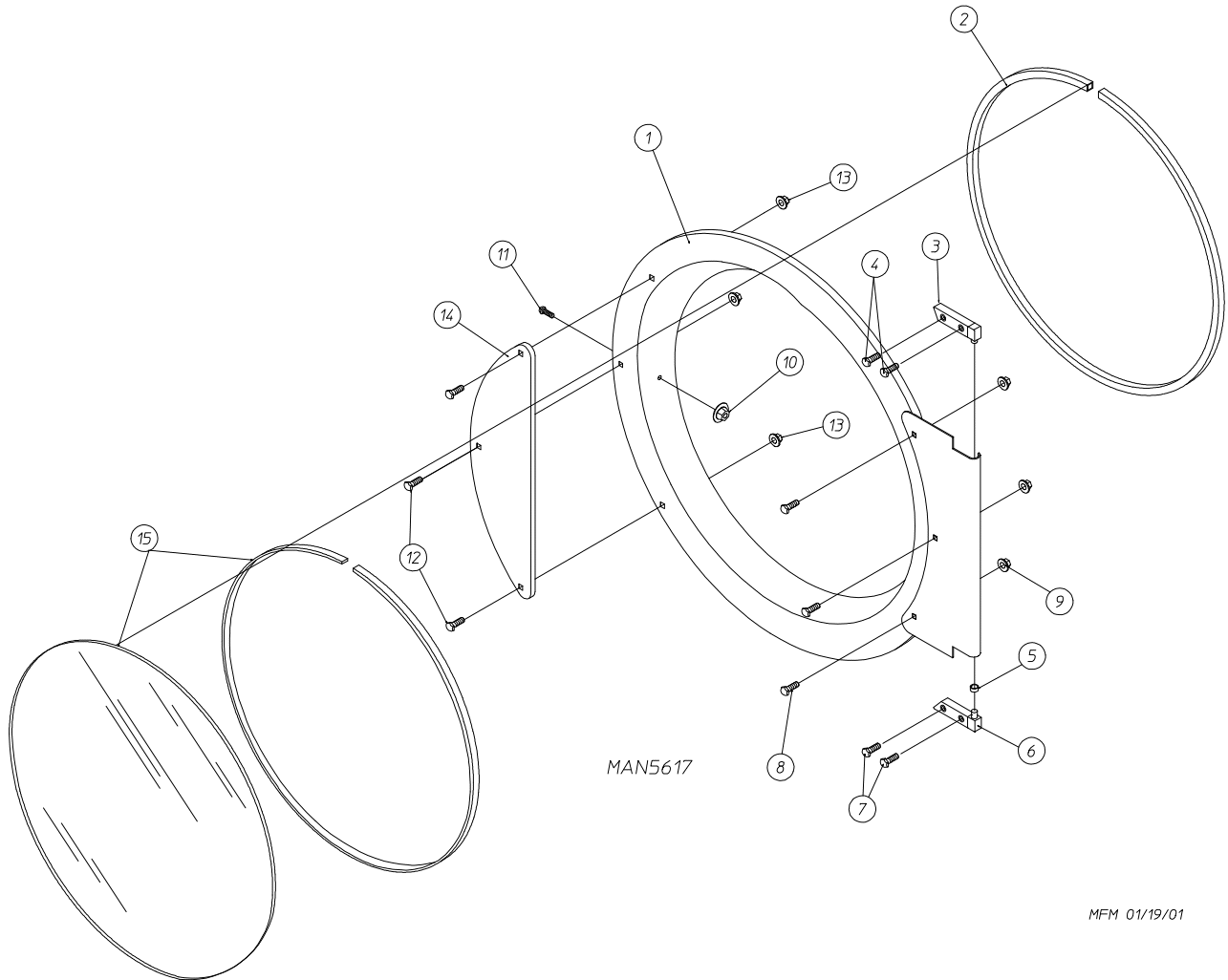

<u>Illus. No.</u>	<u>Part No.</u>	<u>Qty.</u>	<u>Description</u>
1	881150	1	Black Main Door Assembly Complete (includes illus. nos. 1, 2, and 8 through 15)
	881207	1	Stainless Steel Main Door Assembly Complete (includes illus. nos. 1, 2, and 8 through 15)
2	102354	1	Door Gasket
	170730	1	Clear Glass and Gasket Adhesive (10.3 oz. cartridge)
	170731	1	Black Glass and Gasket Adhesive (10.3 oz. cartridge)
3	881152	1	Black Top Hinge Block Assembly (includes illus. nos. 3 and 4)
	881208	1	Stainless Steel Top Hinge Block Assembly (includes illus. nos. 3 and 4)
4	150445	2	1/4-20 x 7/8" Black Cap Head Setscrew
	150443	2	1/4-20 x 7/8" Stainless Steel Cap Head Setscrew
5	153031	1	1/4" Nylon Washer
6	881151	1	Black Bottom Hinge Block Assembly (includes illus. nos. 5 through 7)
	881209	1	Stainless Steel Bottom Hinge Block Assembly (includes illus. nos. 5 through 7)
7	150445	2	1/4-20 x 7/8" Black Cap Head Setscrew
	150443	2	1/4-20 x 7/8" Stainless Steel Cap Head Setscrew
8	150683	3	1/4-20 x 5/8" Black Carriage Bolt
	150682	3	1/4-20 x 5/8" Stainless Steel Carriage Bolt (for models with stainless steel doors)
9	152014	3	1/4-20 Free Spin Wash Nut
10	151010	1	#10-32 Black Hex Acorn Nut
	151009	1	#10-32 Stainless Steel Hex Acorn Nut
11	150120	1	Door Latch Screw
12	150683	3	1/4-20 x 5/8" Black Carriage Bolt
	150682	3	1/4-20 x 5/8" Stainless Steel Carriage Bolt (for models with stainless steel doors)
13	152014	3	1/4-20 Free Spin Wash Nut
14	881210	1	Black Main Door Handle ONLY
	170333	1	Stainless Steel Main Handle ONLY
15	102210	1	20-7/16" Door Glass
	102360	1	Glass/Door Gasket Tape

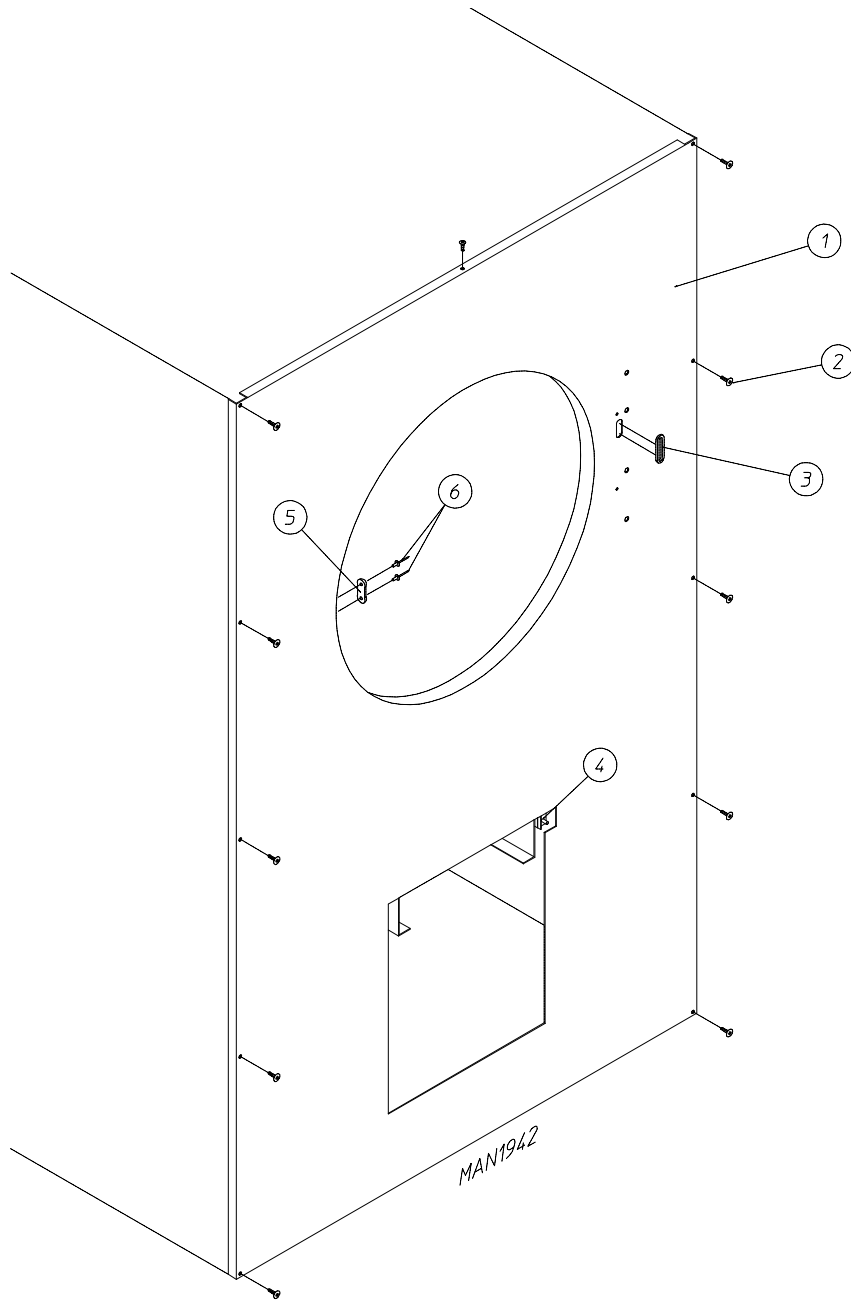

<u>Illus. No.</u>	<u>Part No.</u>	<u>Qty.</u>	<u>Description</u>
1	881994	1	Right Hand Front Panel Complete (includes illus. nos. 1, 3, 5, and 6)
2	150313	11	#10-16 x 1/2" TORX Plus BTN Type 1
3	121405	1	Rubber Grommet
4	-----	1	Lint Drawer Switch (refer to Lint Drawer with Stainless Steel Lint Screen/Lint Drawer Switch Assemblies on page 11)
5	881987	1	Friction Door Latch Kit (includes illus. nos. 5 and 6)
6	154215	2	5/32" Pop Rivet

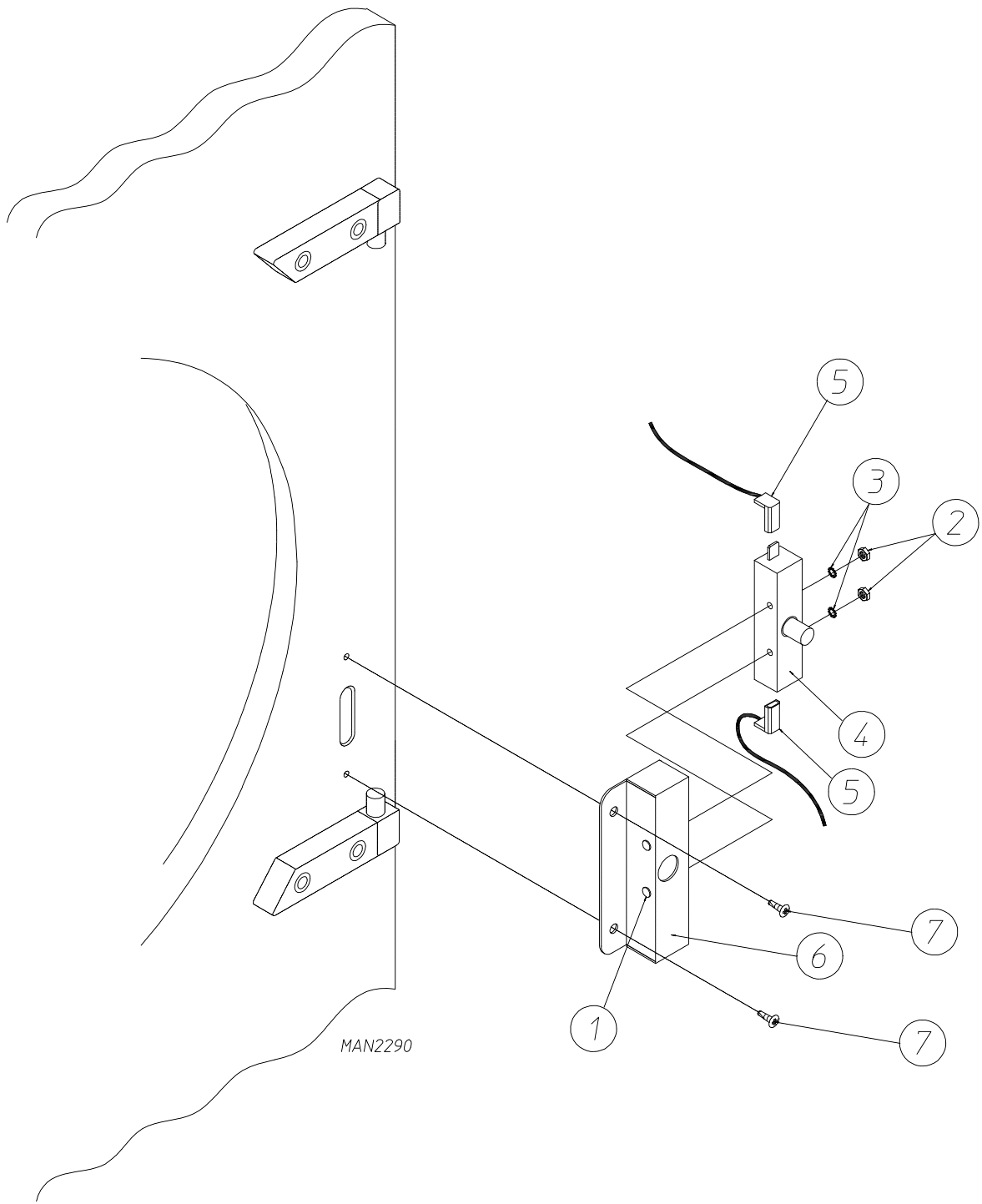

<u>Illus. No.</u>	<u>Part No.</u>	<u>Qty.</u>	<u>Description</u>
1	153566	2	#6-32 x 7/8" Clinch Stud
2	152013	2	#6-32 Hex Nut
3	153010	2	#6 Star Washer
4	137005	1	Single-Pole Door Switch
5	122636	2	Flag Terminal
6	881211	1	Main Door Switch Housing
7	150301	2	#8-18 x 7/16" Phillips Pan Head TEK Screw

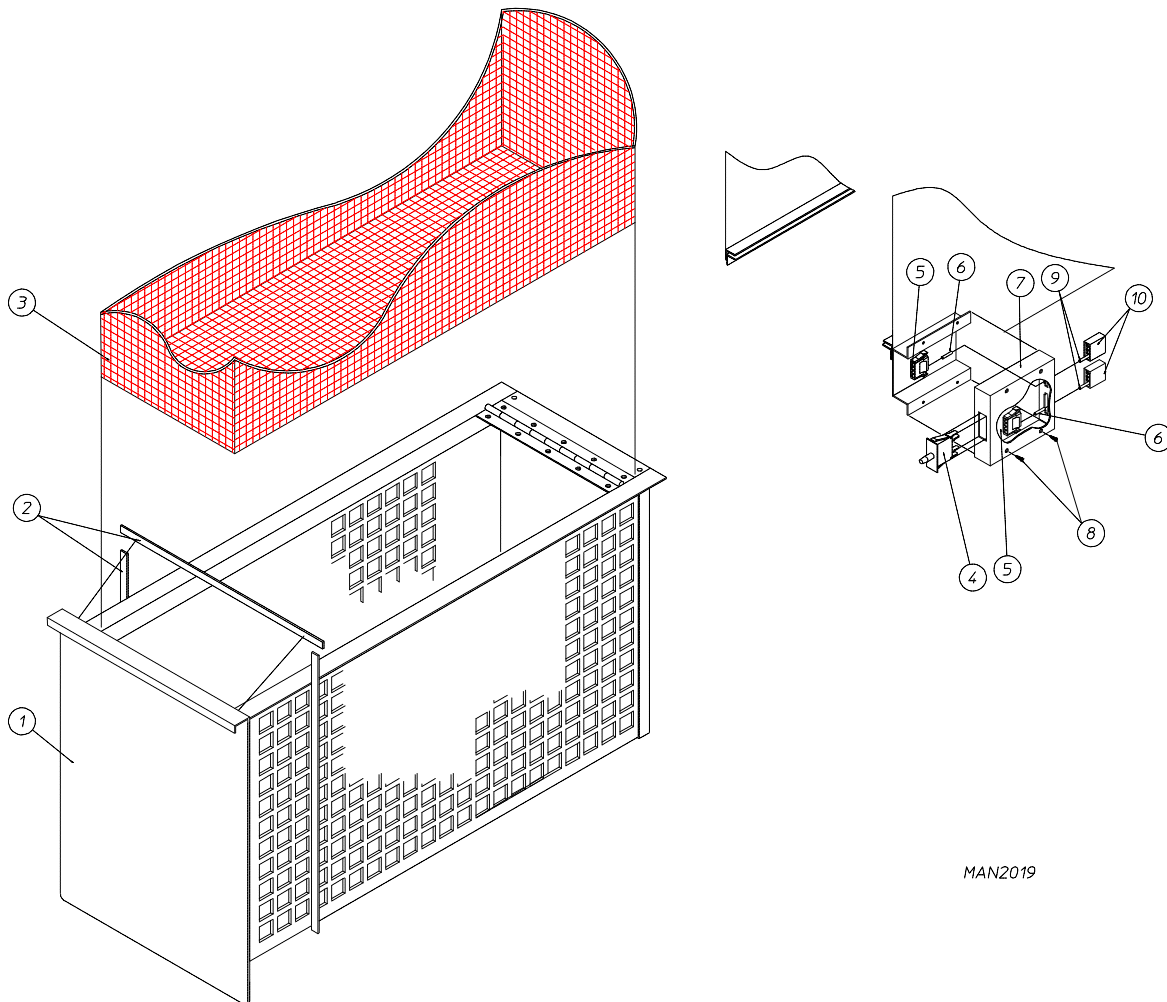

MAN2019

<u>Illus. No.</u>	<u>Part No.</u>	<u>Qty.</u>	<u>Description</u>
1	883503*	1	Lint Drawer Assembly (includes illus. nos. 1 and 2)
	881464	1	Stainless Steel Lint Drawer Assembly (includes illus. nos. 1 and 2)
2	117605	5	Gasket (sold by the foot)
3	802205	1	Lint Screen Assembly
4	122116	1	Lint Drawer Switch
5	122605	2	4-Pin Socket Connector
6	122701	4	Socket Terminal ONLY
	122801	1	Socket/Pin Extraction Tool
7	800478	1	Lint Drawer Switch Box Assembly (includes illus. nos. 4 through 7)
	304135	1	Lint Drawer Switch Box ONLY
8	150301	2	#8-18 x 7/16" Phillips Pan Head TEK Screw
9	122700	4	Pin Terminal ONLY
10	122604	2	4-Pin Connector ONLY

* Specify color when ordering.

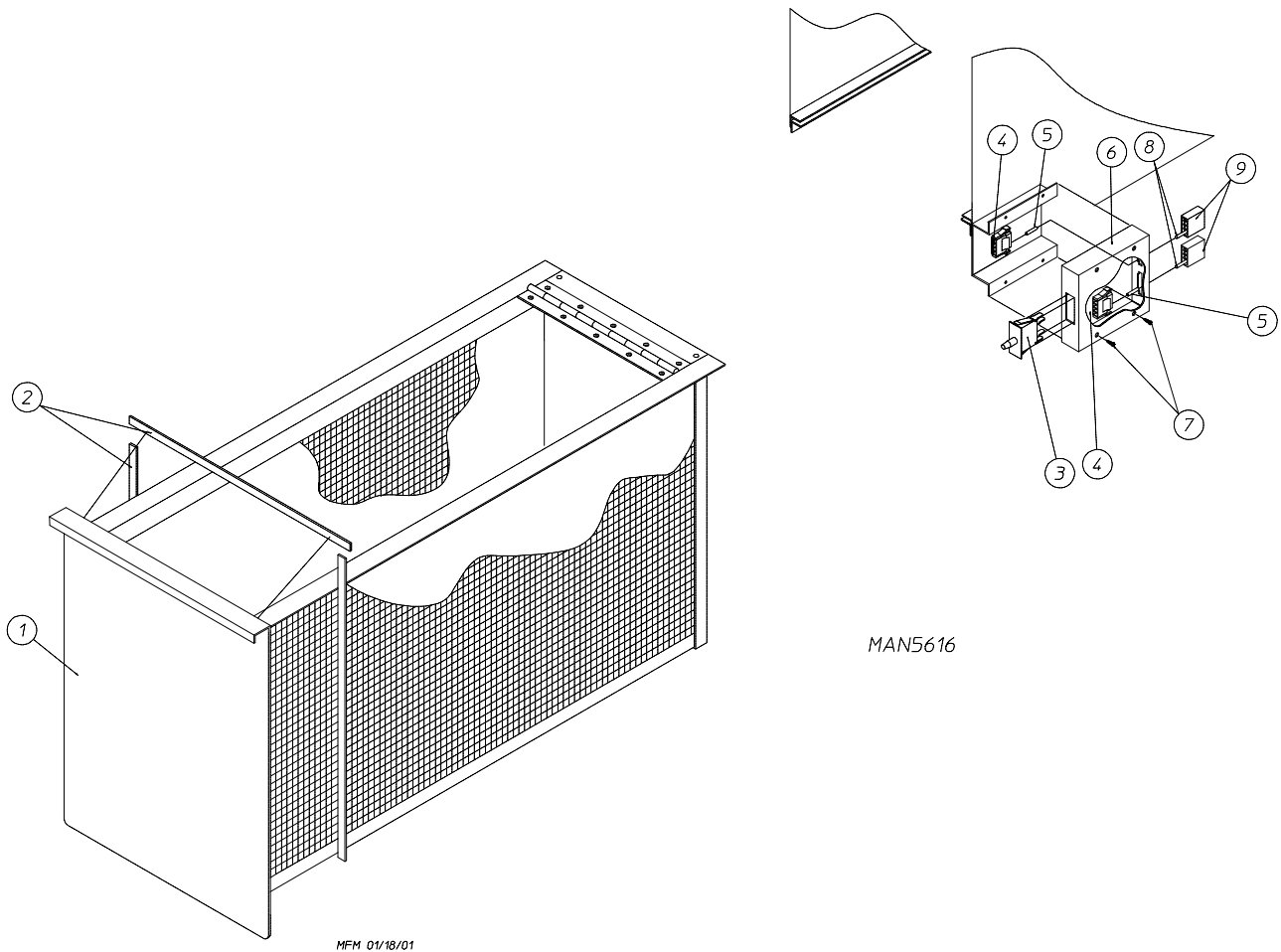

<u>Illus. No.</u>	<u>Part No.</u>	<u>Qty.</u>	<u>Description</u>
1	882871	1	White Lint Drawer with Stainless Steel Screen
2	117605	5	Gasket (sold by the foot)
3	122116	1	Lint Drawer Switch
4	122605	2	4-Pin Socket Connector
5	122701	4	Socket Terminal ONLY
	122801	1	Socket/Pin Extraction Tool
6	800478	1	Lint Drawer Switch Box Assembly (includes illus. nos. 4 through 7)
	304135	1	Lint Drawer Switch Box ONLY
7	150301	2	#8-18 x 7/16" Phillips Pan Head TEK Screw
8	122700	4	Pin Terminal ONLY
9	122604	2	4-Pin Connector ONLY

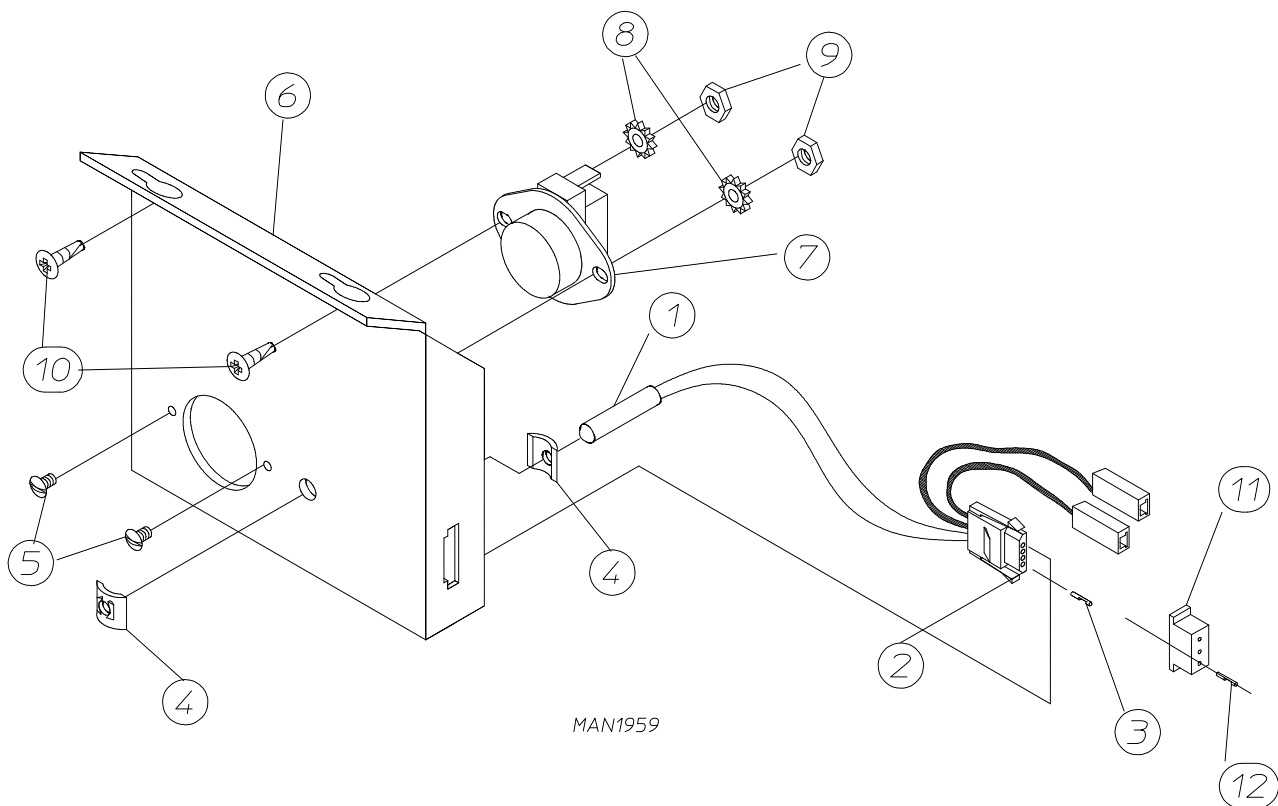

<u>Illus. No.</u>	<u>Part No.</u>	<u>Qty.</u>	<u>Description</u>
1	880251	1	1/4" Temperature Sensor Probe Assembly (includes illus. nos. 1 through 4)
2	122605	1	4-Pin Socket Connector
3	122701	4	Socket Terminal ONLY
4	154007	2	1/4" Tinnerman Push On Fastener
5	150000	2	#6-32 x 1/4" Round Head Machine Screw
6	802174	1	Sensor Bracket Assembly Complete (includes illus. nos. 1 through 9)
	323626	1	Temperature Sensor Bracket ONLY
7	130301	1	225° Manual Reset Thermostat
8	153010	2	#6 Star Washer
9	152000	2	#6-32 Hex Nut
10	150301	2	#8-18 x 7/16" Phillips Pan Head TEK Screw
11	122604	1	4-Pin Connector ONLY
12	122700	4	Pin Terminal ONLY
--	122801	1	Socket/Pin Extraction Tool

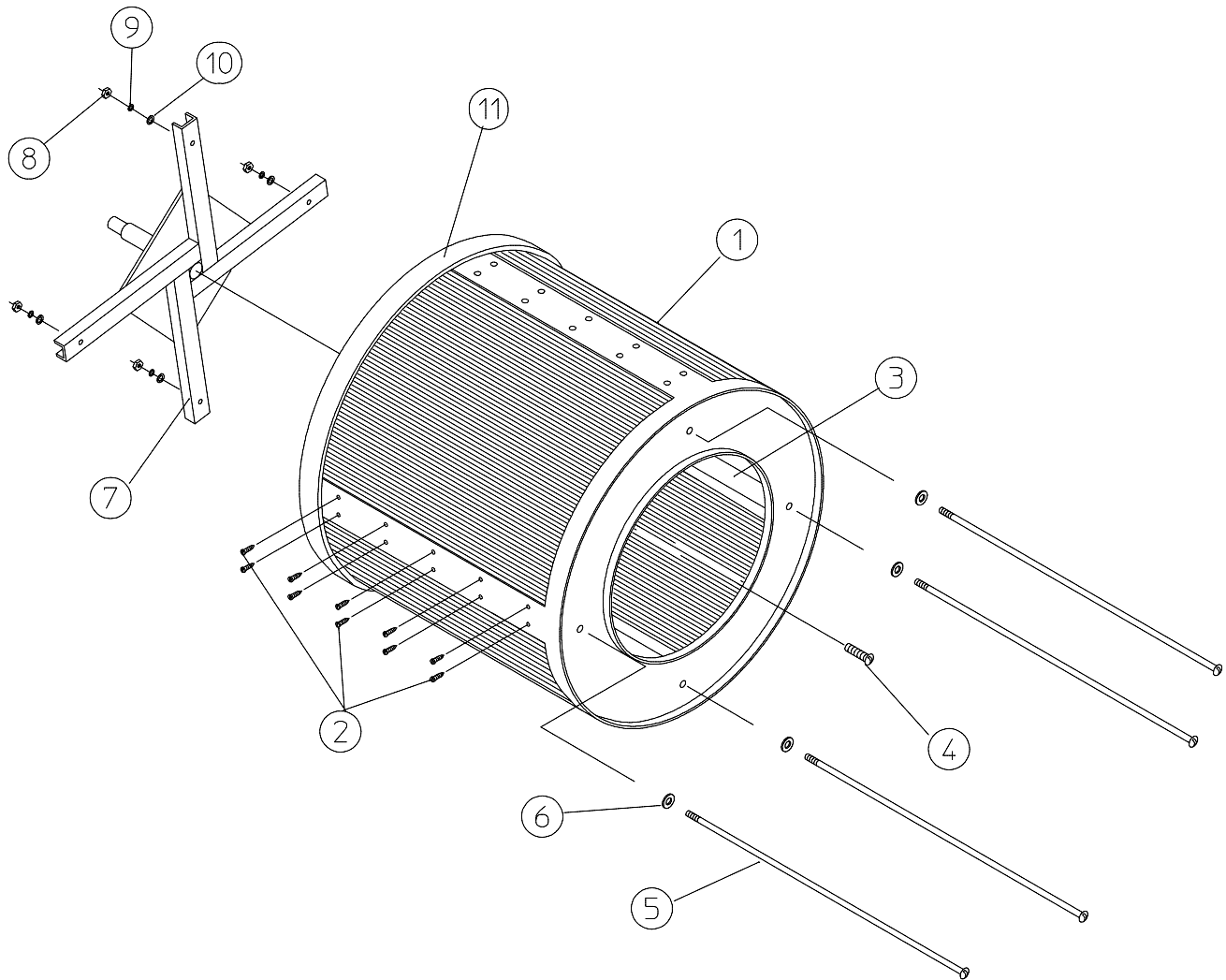

MAN0251

<u>Illus. No.</u>	<u>Part No.</u>	<u>Qty.</u>	<u>Description</u>
1	880818	1	Basket (tumbler) ONLY without Felt Collar (includes illus. nos. 1 through 3)
	880827	1	Reversing Basket (tumbler) and Support Assembly Complete (includes illus. nos. 1 through 11)
2	154210	40	5/32" x 3/16" Pop Rivet
3	301308	4	Basket (tumbler) Rib ONLY
4	150500	1	5/16-18 x 3/4" Socket Button Head Screw
5	100905	4	3/8-16 x 37" Tie Rod
6	153004	4	3/8" Flat Washer
7	800615	1	Reversing Basket (tumbler) Support ONLY
8	152005	4	3/8-16 Hex Nut
9	153005	4	3/8" Lock Washer
10	153004	4	3/8" Flat Washer
11	116000	1	Felt Collar ONLY
--	401010	1	#847 Construction Mastic

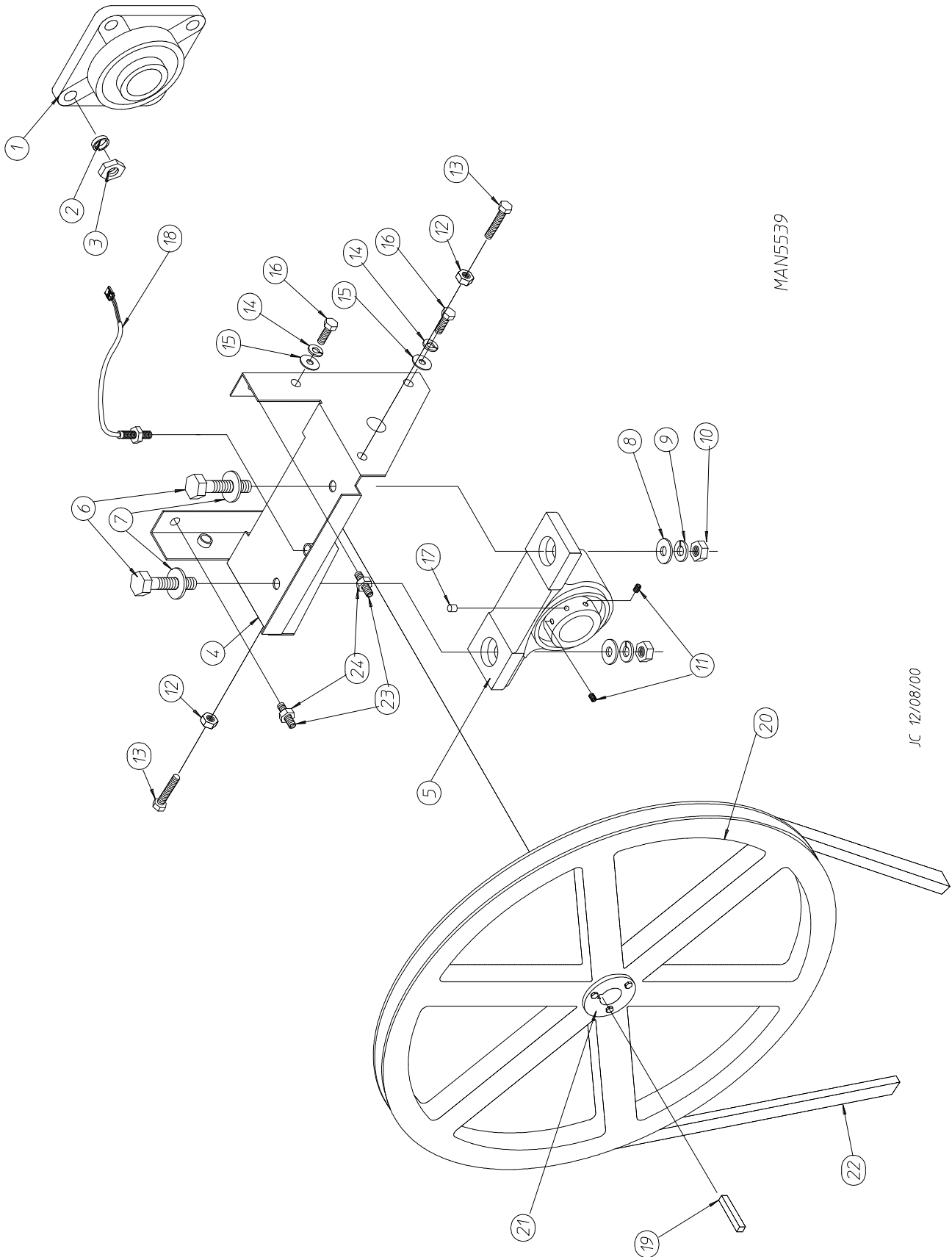

<u>Illus. No.</u>	<u>Part No.</u>	<u>Qty.</u>	<u>Description</u>
1	880220	1	1-3/4" Flange Bearing
2	153025	4	9/16" Lock Washer
3	152050	4	9/16-12 Hex Nut
4	882545	1	Pillow Block Bearing Assembly Complete with Rotational Sensor (includes illus. nos. 4 through 18)
	882543	1	Pillow Block Bearing Platform ONLY
5	880779	1	1-3/8" Pillow Block Bearing
6	150601	2	3/8-16 x 2" Hex Bolt
7	153004	2	3/8" Flat Washer
8	153004	2	3/8" Flat Washer
9	153005	2	3/8" Lock Washer
10	152005	2	3/8-16 Hex Nut
11	154326	2	5/16-24 x 3/8" Setscrew
12	152004	2	5/16-18 Hex Nut
13	150621	2	5/16-18 x 1-1/2" Tap Bolt
14	153002	4	5/16" Lock Washer
15	153004	6	3/8" Flat Washer
16	150501	4	5/16-18 x 3/4" Tap Bolt
17	102120	1	Sintered 8 Magnet
18	824807	1	Rotational Sensor Assembly
19	100735	1	Shaft Key
20	101118	1	18-3/4" Pulley
21	101119	1	1-3/8" Taper Lock Bushing
22	100106	1	5L-690 V-Belt (basket [tumbler] to idler)
23	150610	2	5/16-18 x 1-1/2 Allen Setscrew
24	152004	2	5/16-18 Hex Nut

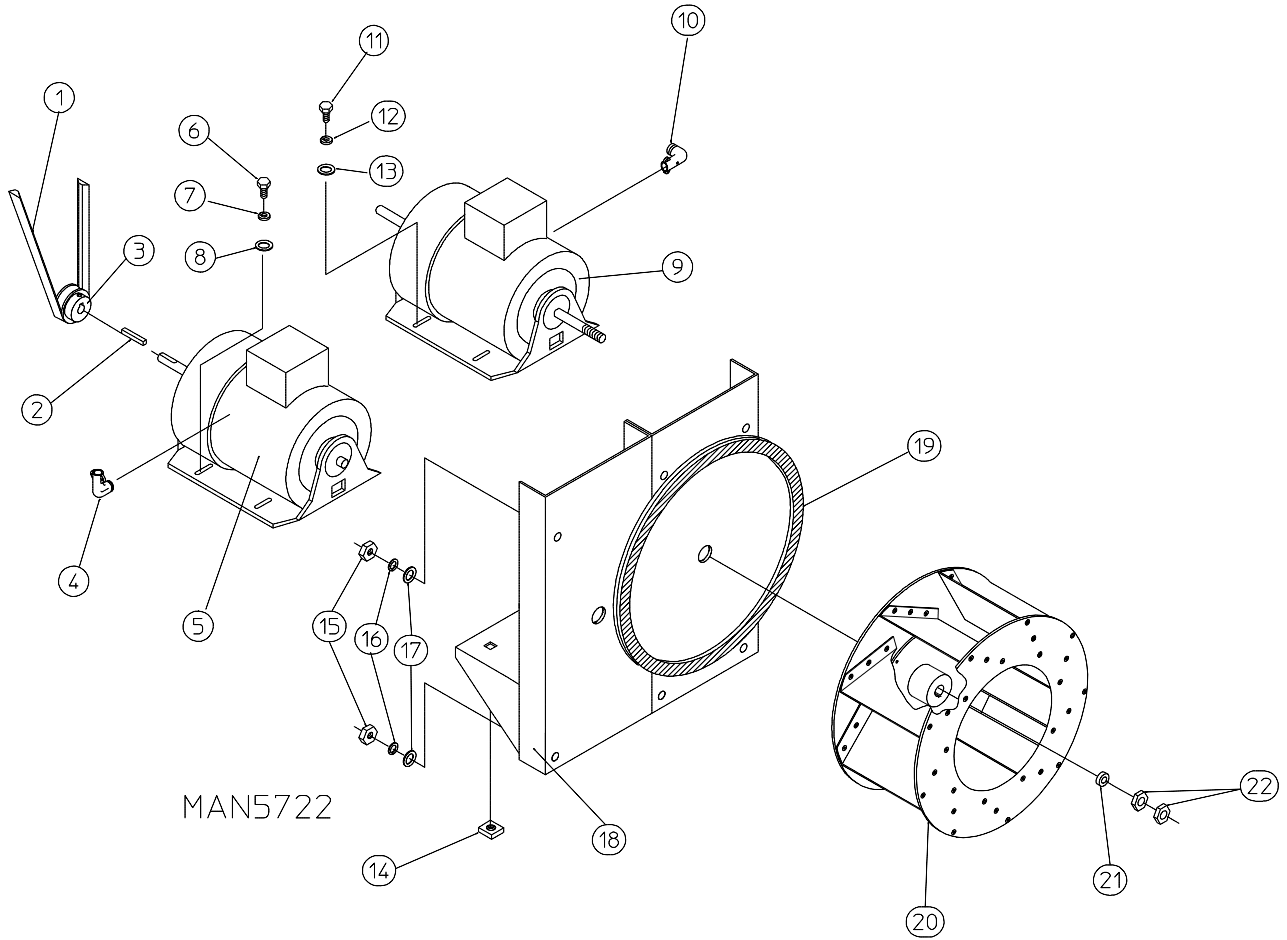

CALBERT 03/23/01

<u>Illus. No.</u>	<u>Part No.</u>	<u>Qty.</u>	<u>Description</u>
1	100109	1	4L-630 V-Belt (motor to idler)
2	100701	1	3/16" x 3/16" x 1" Key
3	101130	1	5/8" x 2-1/2" Motor Pulley (60 Hz Only)
	101139	1	5/8" x 2-3/4" Motor Pulley (50 Hz Only)
4	120200	1	3/8" x 90° Connector
5	181003*	1	1/2 HP 208/230/380/460v 3ø 50/60 Hz Totally Enclosed, Fan-Cooled (T.E.F.C.) Motor (56Z frame)
6	150501	4	5/16-18 x 3/4" Tap Bolt
7	153002	4	5/16" Lock Washer
8	153001	4	5/16" Flat Washer
9	181043*	1	3 HP 220/230/380/460v 3ø 50/60 Hz Totally Enclosed, Fan-Cooled (T.E.F.C.) Motor with 3/4" Shaft (56Z frame)
10	120200	1	3/8" x 90° Connector
11	150501	4	5/16-18 x 3/4" Tap Bolt
12	153002	4	5/16" Lock Washer
13	153001	4	5/16" Flat Washer
14	154000	8	5/16" Tinnerman Nut
15	152004	7	5/16-18 Hex Nut
16	153002	7	5/16" Lock Washer
17	153001	7	5/16" Flat Washer
18	800920	1	Reversing Motor Mount ONLY (56Z frame)
	883027*	1	60 Hz Reversing Totally Enclosed, Fan-Cooled (T.E.F.C.) Motor Mount Assembly Complete (includes illus. nos. 2 through 14 and 18 through 22)
	883026*	1	50 Hz Reversing Totally Enclosed, Fan-Cooled (T.E.F.C.) Motor Mount Assembly Complete (includes illus. nos. 2 through 14 and 18 through 22)
19	117604	4	Neoprene Sponge Tape (sold by the foot)
20	802027	1	16" Riveted High Flow Impellor (60 Hz models)
	802024	1	16" Riveted High Flow Impellor (50 Hz models)
21	153065	1	1-1/2" Outside Diameter x 1/2" Washer
22	152006	2	1/2-20 Left Hand Jam Nut

* Check part number on motor data label to verify correct motor.

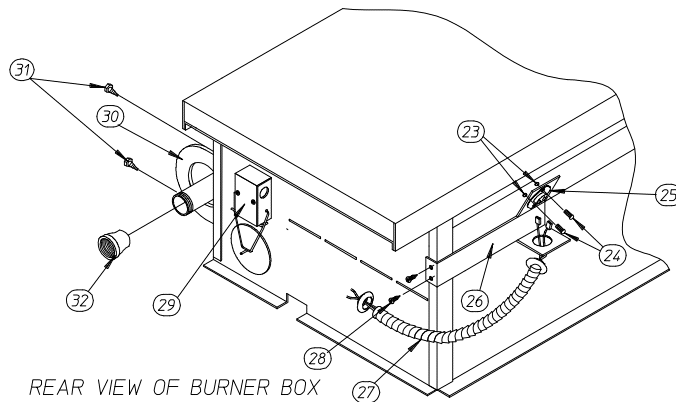
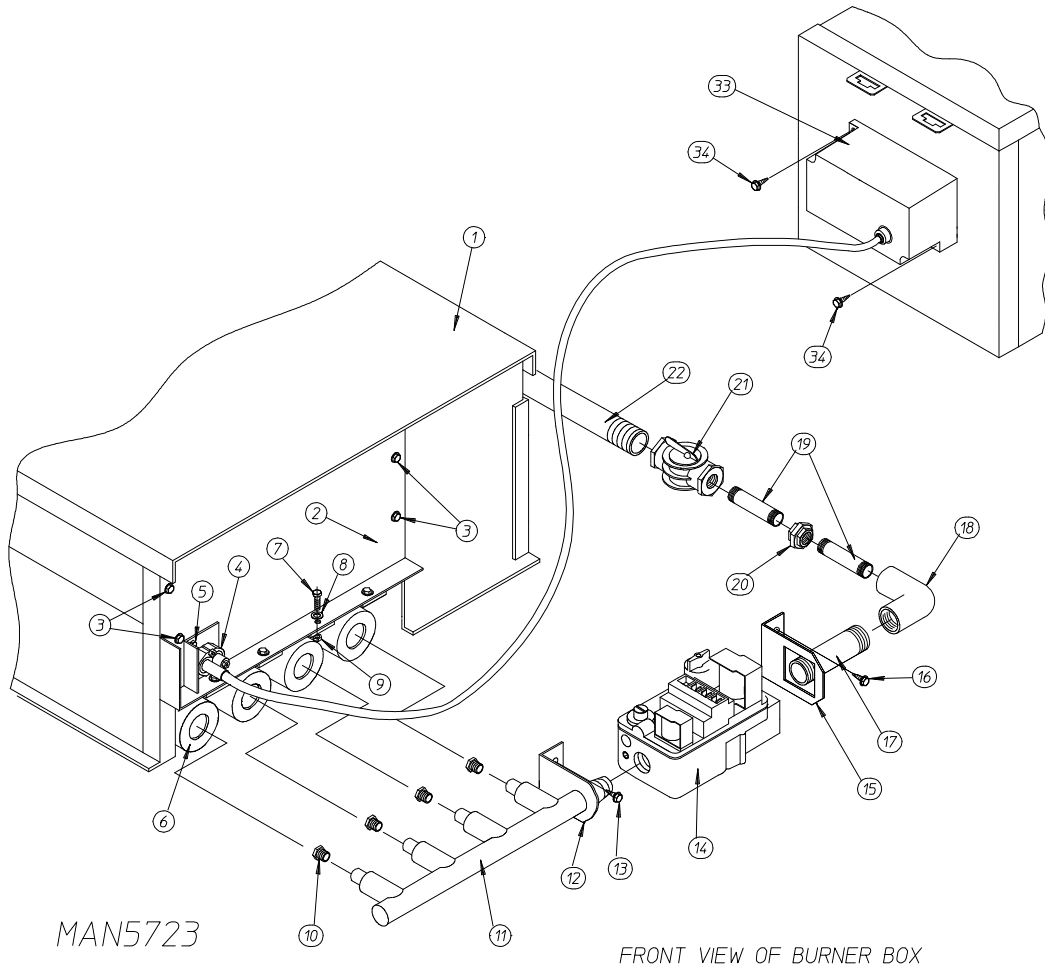

MFM 03/23/01

<u>Illus. No.</u>	<u>Part No.</u>	<u>Qty.</u>	<u>Description</u>
1	802237	1	Burner Box ONLY
	881258*	1	Natural Gas Burner Assembly II Complete Less Orifice (includes illus. nos. 1 through 9 and 11 through 32)
	881257*	1	Liquid Propane (L.P.) Burner Assembly II Complete Less Orifice (includes illus. nos. 1 through 9 and 11 through 32)
2	802240	1	Burner Shield
3	150309	4	#10-16 x 1/2" Hex Head Crimptite Screw

<u>Illus. No.</u>	<u>Part No.</u>	<u>Qty.</u>	<u>Description</u>
4	128915	1	Direct Spark Ignition (DSI) Ignitor/Flame-Probe ONLY
	880330	1	High Voltage (HV) Wire and Connector ONLY
	880134	1	Direct Spark Ignition (DSI) Ignitor/Flame-Probe Assembly Complete with High Voltage (HV) Wire Connector
	305410	-	Ignitor Gap Tool...Not Illustrated
5	150300	2	#10-16 x 1/2" Hex Washer TEK Screw
6	141105	4	Large Burner Tube
7	150103	4	#8-32 x 3/4" Phillips Pan Head Machine Screw
8	153000	4	#8 Steel Burr
9	151001	4	#8-32 Pal Nut
10**	140856	4	#23 Burner Orifice (natural gas) ONLY
	140811	4	#41 Burner Orifice (liquid propane [L.P.] gas) ONLY
11	141210	1	3/4" Manifold (4-port)
12	323737	1	Pipe Bracket (bent)
13	150309	2	#10-16 x 1/2" Hex Head Crimptite Screw
14	128928	1	24 VAC Direct Spark Ignition (DSI) Gas Valve (natural gas) ONLY
	881052	1	24 VAC Direct Spark Ignition (DSI) Gas Valve (liquid propane [L.P.] gas) ONLY
15	323763	1	Gas Valve Bracket
16	150309	2	#10-16 x 1/2" Hex Head Crimptite Screw
17	142715	1	1/2" x 2" Nipple
18	142511	1	3/4" x 1/2" Reducing Elbow
19	142709	2	3/4" x 2" Nipple
20	142601	1	3/4" Union
21	141300	1	3/4" Union Shutoff
22	142829	1	3/4" x 20" Pipe Nipple
23	151000	2	#6-32 Pal Nut
24	150001	2	#6-32 x 1/2" Round Head Machine Screw
25	130403	1	330° Automatic Hi-Limit Thermostat
26	319704	1	Hi-Limit Mounting Bracket
27	824533	1	Sail Switch to Hi-Limit Harness
28	150309	2	#10-16 x 1/2" Hex Head Crimptite Screw
29	-----	1	Sail Switch (refer to Sail Switch Assembly on page 22)
30	323737	1	Pipe Bracket (bent)
31	150309	2	#10-16 x 1/2" Hex Head Crimptite Screw
32	142924	1	1" to 3/4" Reducing Coupling
--	881016**	1	ADG-81 Burner Liquid Propane (L.P.) Conversion Kit with Orifice
33	128935	1	Direct Spark Ignition (DSI) Module Johnson Controls
34	150299	4	#10 x 1" Hex Washer Self Drilling Screw

* Burner orifices *are not included* and **must be** ordered separately.

** Consult factory for elevations over 2,000 feet.

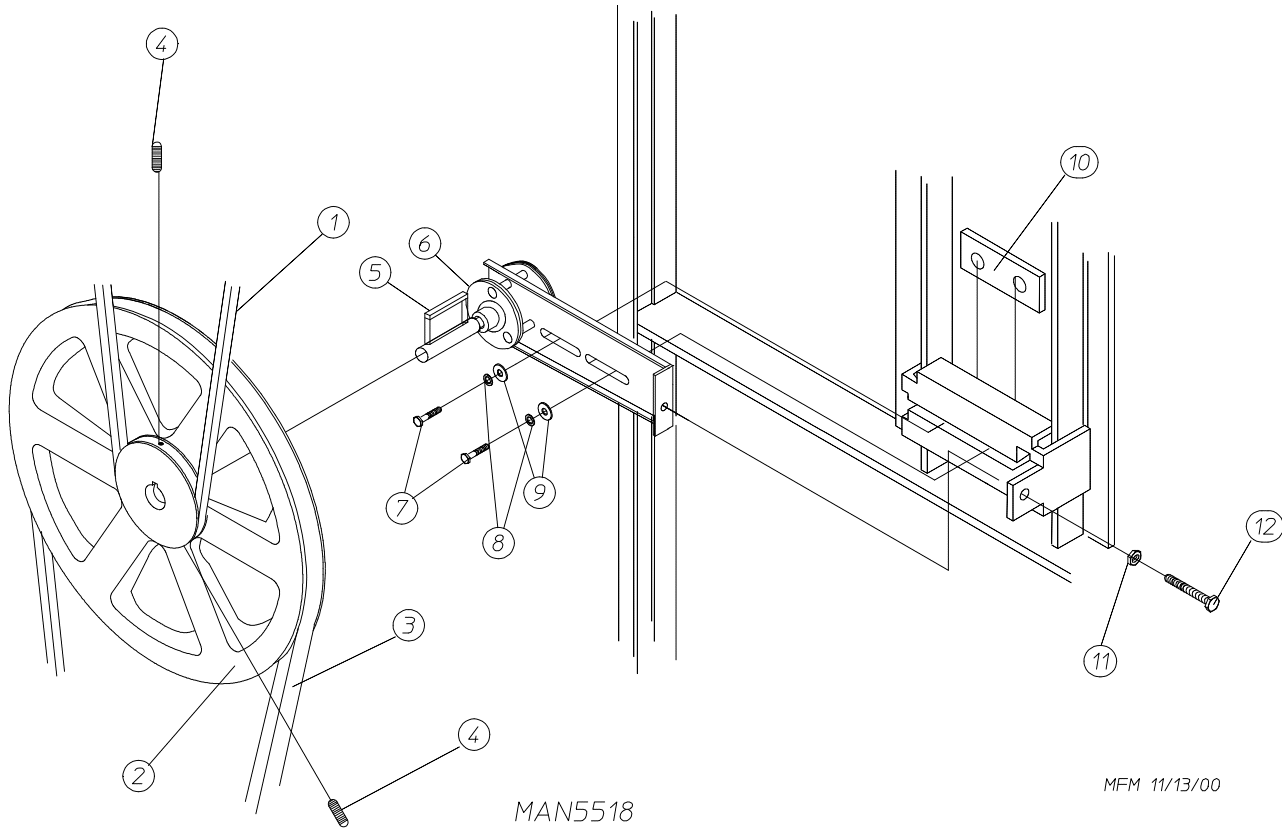

<u>Illus. No.</u>	<u>Part No.</u>	<u>Qty.</u>	<u>Description</u>
1	100106	1	5L-690 V-Belt
2	101140	1	14" x 3" Compound Pulley
3	100109	1	4L-650 V-Belt (idler to motor)
4	154301	2	5/16-18 x 1" Allen Setscrew
5	100705	1	3/16" x 3/16" x 1-3/8" Key
6	882576	1	Idler Bearing Assembly Complete (includes illus. nos. 5 through 12)
7	150617	2	3/8-16 x 1" Hex Head Machine Bolt
8	153005	2	3/8" Lock Washer
9	153004	2	3/8" Flat Washer
10	801009	1	Idler Square Washer
11	152004	1	5/16-18 Hex Nut
12	150509	1	5/16-18 x 3" Hex Head Machine Bolt

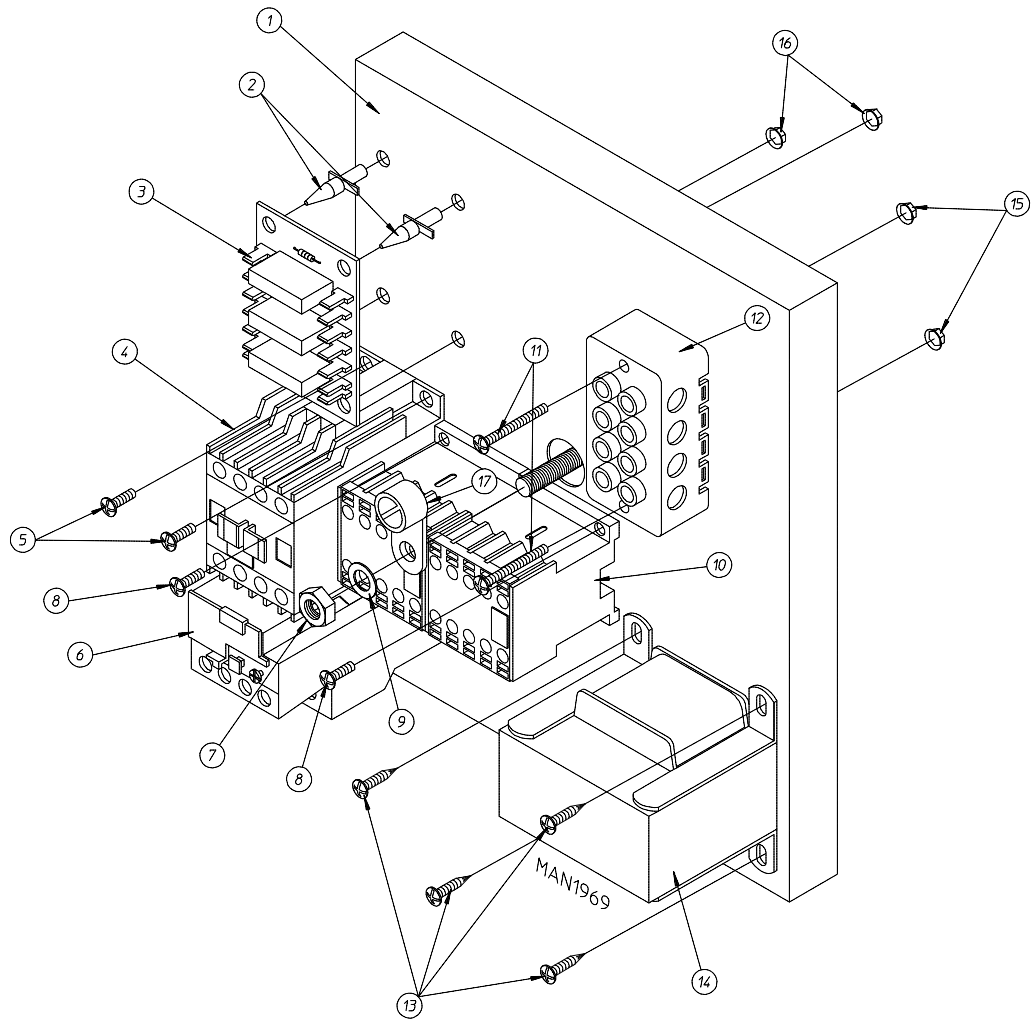

<u>Illus. No.</u>	<u>Part No.</u>	<u>Qty.</u>	<u>Description</u>
1	323743	1	Relay Panel ONLY
2	137013	4	Nylon Standoff
3	137060	1	Arc Suppressor (A.S.) Board
4	132445	1	3 HP Contactor
5	150103	4	#8-32 x 3/4" Phillips Pan Head Machine Screw
6	132467	1	Blower Overload (for 208 volt and 230 volt models Only)
	132468	1	Blower Overload (for 380 volt and 600 volt models Only)
7	152004	1	5/16-18 Hex Nut
8	150103	3	#8-32 x 3/4" Phillips Pan Head Machine Screw
9	153002	1	5/16" Lock Washer
10	882386	1	Reversing Contactor - 24 VAC
11	150008	2	#6-32 x 1-1/4" Round Head Machine Screw
12	120701	1	4-Position Terminal Block
13	150300	4	#10-16 x 1/2" Hex Washer TEK Screw
14	-----	1	Step Down Transformer (refer to Step Down Transformer Usage Listing on page 23)
15	151000	2	#6-32 Pal Nut
16	151001	4	#8-32 Pal Nut
17	121012	1	Ground Lug

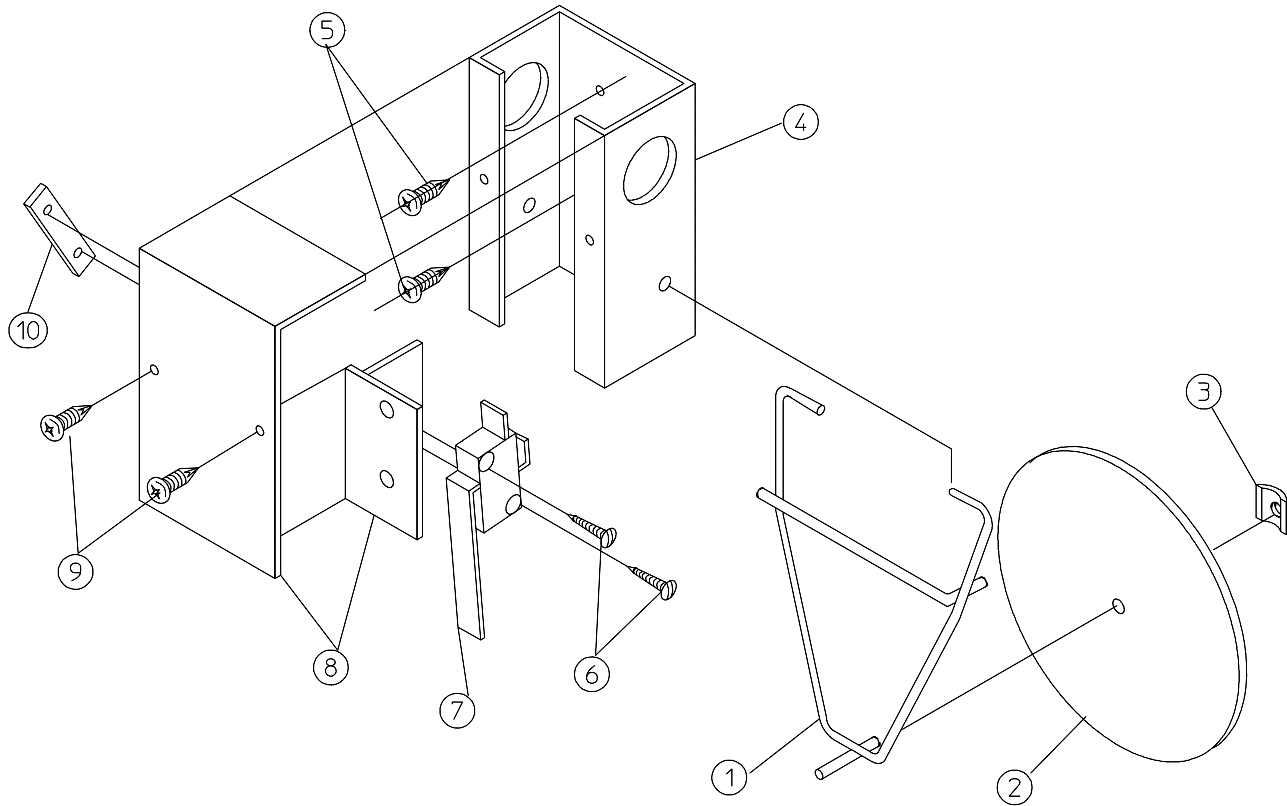

MAN0440

<u>Illus. No.</u>	<u>Part No.</u>	<u>Qty.</u>	<u>Description</u>
1	105500	1	Sail Switch Actuator Rod
2	319202	1	Sail Switch Damper (flat)
3	154002	1	1/8" Push On Fastener
4	802800	1	Sail Switch Box with Cover and Bracket ONLY (includes illus. nos. 4, 8, and 9)
	802801	1	Sail Switch Box Assembly Complete (includes illus. nos. 1 through 4 and 6 through 10)
5	150300	2	#10-16 x 1/2" Hex Washer TEK Screw
6	150303	2	#4 x 3/4" Pan Head "A" Machine Screw
7	122200	1	Sail Switch ONLY
8	802799	1	Sail Switch Box Cover and Bracket ONLY
9	150309	2	#10-16 x 1/2" Hex Head Crimptite Screw
10	154004	1	Twin Speed Nut

Step Down Transformer Usage Listing (Reversing Relay Box)			
Heat	Voltage	Wire Service	Transformer Part Number
			Microprocessor Models
Gas / Steam	380	3 or 4	132059
	416	3 or 4	132062
	460/480	3 or 4	132053
	575	3 or 4	132050

NOTE: Step Down Transformer used on models mfd. for 380 volts or higher.

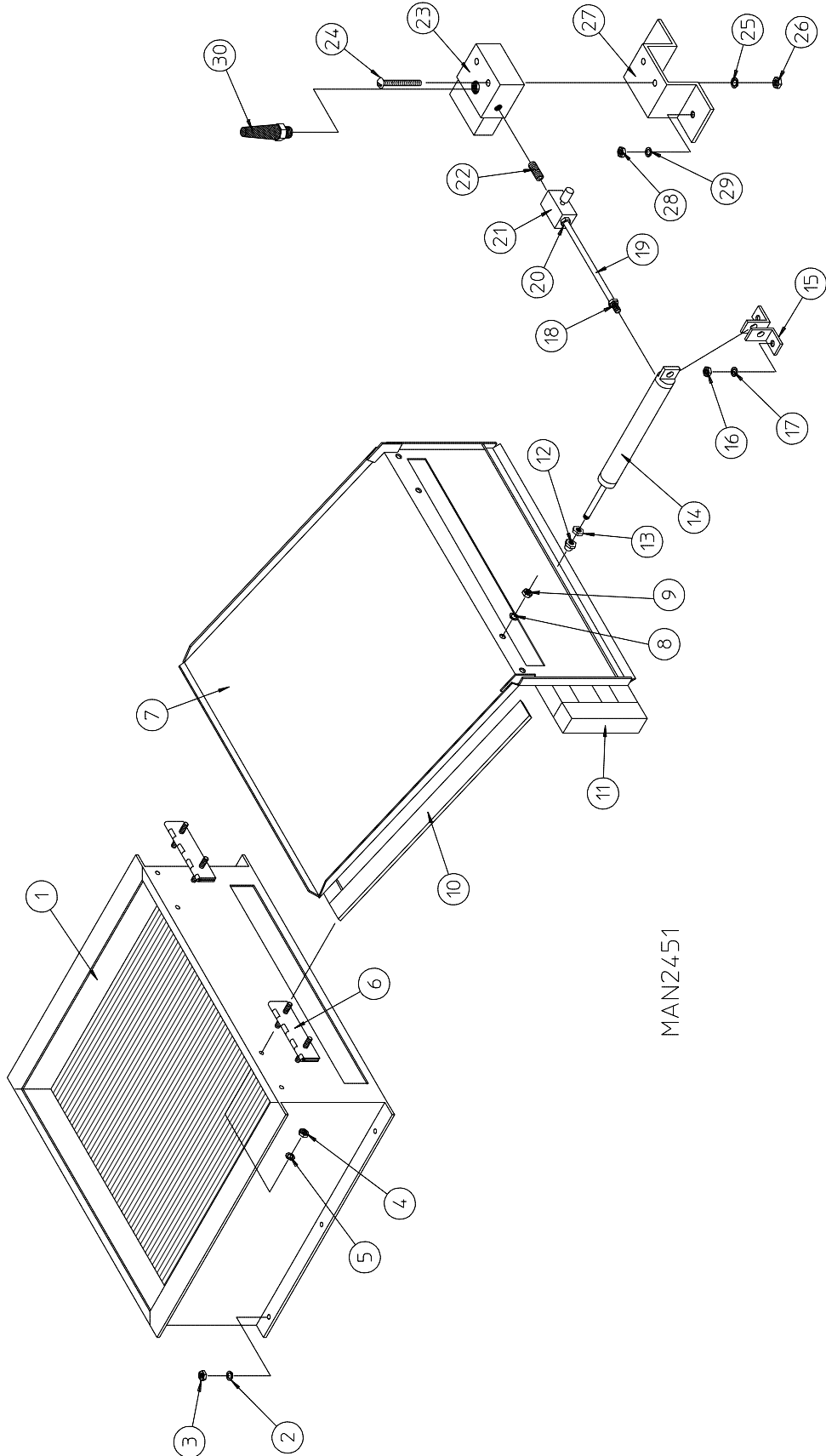

<u>Illus. No.</u>	<u>Part No.</u>	<u>Qty.</u>	<u>Description</u>
1	165009	1	Steam Coil Assembly
2	153002	6	5/16" Lock Washer
3	152004	6	5/16-18 Hex Nut
4	152002	4	1/4-20 Hex Nut
5	153007	4	1/4" Lock Washer
6	820321	2	Steam Damper Hinge Assembly
7	803415	1	Steam Damper Assembly (includes illus. nos. 7, 10, and 11)
8	153007	4	1/4" Lock Washer
9	152002	4	1/4-20 Hex Nut
10	115995	108	Steam Damper Gasket (sold by the inch)
11	102350	1	Steam Damper Foam (68-1/2" length)
12	151007	1	7/16-20 Stainless Steel Acorn Nut
13	152007	1	7/16-20 Hex Nut
14	100497	1	1-1/4" Bore x 3" Stroke Piston
15	100492	1	Piston Support Bracket
16	152002	4	1/4-20 Hex Nut
17	153007	4	1/4" Lock Washer
18	100472	1	1/4" x 1/8" Connector
19	143110	1	1/4" Tubing (sold by the foot)
20	100472	1	1/4" x 1/8" Connector
21	100496	1	1/8" Needle Valve
22	143238	1	1/8" Close Nipple
23	100498	1	3-Way Micro Valve - 24 VAC
24	150002	2	#6-32 x 1" Phillips Round Head Machine Screw
25	153010	2	#6 Star Washer
26	152000	2	#6-32 Hex Nut
27	330987	1	Micro Valve Support Bracket
28	152002	2	1/4-20 Hex Nut
29	153007	2	1/4" Lock Washer
30	100520	1	1/8" N.P.T. Silencer (muffler)

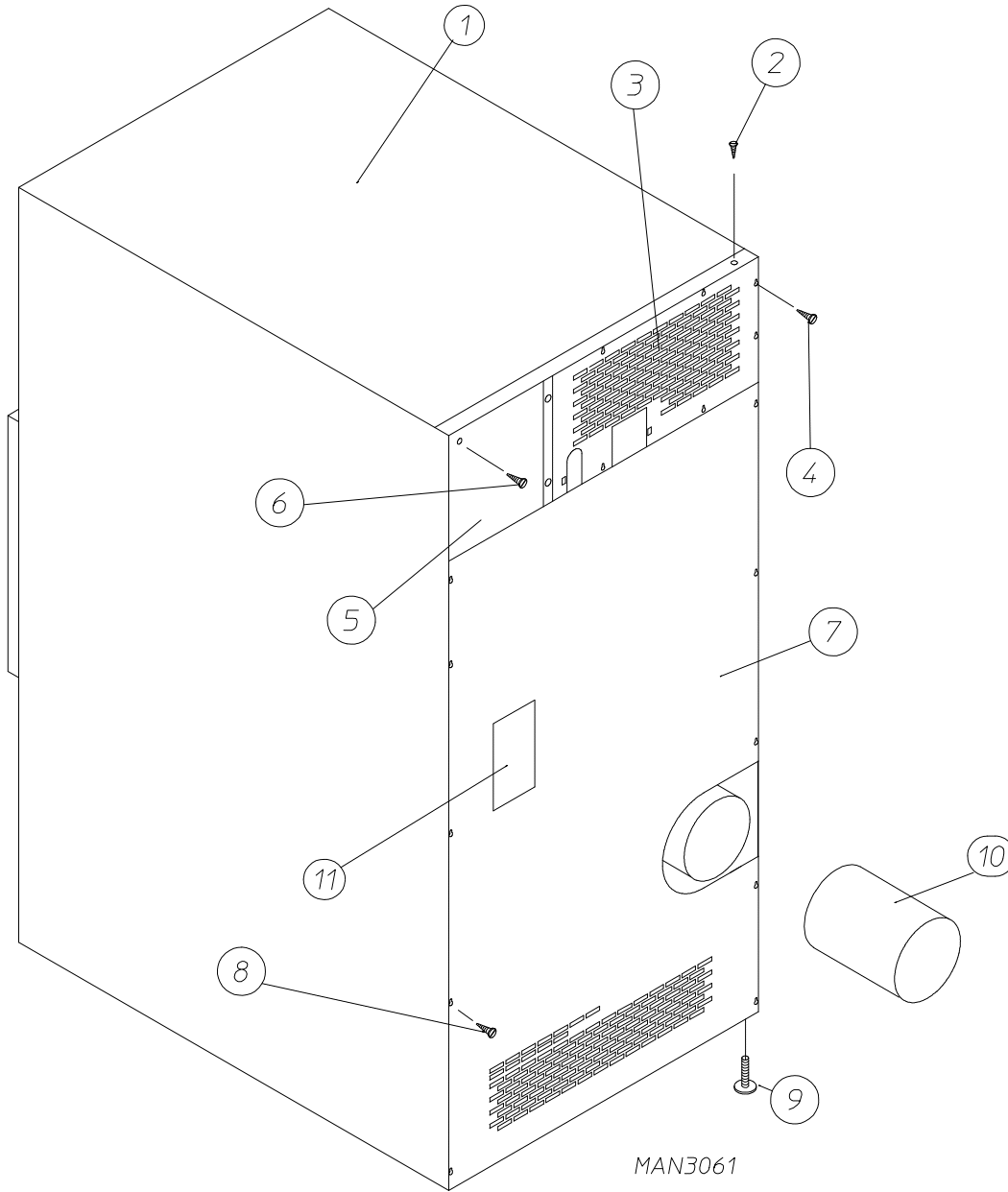

<u>Illus. No.</u>	<u>Part No.</u>	<u>Qty.</u>	<u>Description</u>
1	312527	1	Outer Top Assembly (for gas models Only)
2	150301	8	#8-18 x 7/16" Phillips Pan Head TEK Screw
3	323759	1	Top Back Guard Assembly (26-7/8" x 13-15/16")
4	150301	6	#8-18 x 7/16" Phillips Pan Head TEK Screw
5	323749	1	Rear Electrical Box Cover (10-13/16" x 9-3/4")
6	150301	6	#8-18 x 7/16" Phillips Pan Head TEK Screw
7	314511	1	Lower Back Guard
8	150301	10	#8-18 x 7/16" Phillips Pan Head TEK Screw
9	103500	4	Leveling Leg
10	104005	1	12" Damper Assembly
11	112519	1	"Routine Maintenance Schedule" Label

<u>Part No.</u>	<u>Description</u>
112280	“Clean Lint Screen” Label
112534	“Phase 5 OPL Program Location Summary” Label
122804	Manometer (hydro gauge) for Measuring Gas Pressure
114001	“CAUTION - Exhaust/Lint Screen” Label
114006	“WARNING - Fire Hazards” Label
120100	3/8” Straight (BX) Connector
120300	3/8” x 45° (BX) Connector
120400	3/8” Red Jacket (BX) Insulator
120500	3/8” Jiffy Clip (BX) Retainer Clip
120600	3/8” Greenfield (BX)
120800	1/4” In-Line Connector
120802	Red Butt Connector
120902	#74B Wire Nut
120903	Crimp-On Wire Nut
121014	1/4” Insulated (female) Terminal
121499	5-1/2” Wire Tie
121500	8” Harness Tie
121503	Harness Tie Mounting Clip
404500	Almond Brush-In-Cap Bottle Touch-Up Paint
404502	White Brush-In-Cap Bottle Touch-Up Paint
404506	Almond “B” Brush-In-Cap Bottle Touch-Up Paint
404507	Cornflower Blue Brush-In-Cap Bottle Touch-Up Paint
882458	Basket (tumbler) Bearing Puller

ADC450452

1 - 05/04/01-25

2 * 11/20/01-25

3 * 09/03/02-25

