

WACO CLASSIC



INSTRUCTION MANUAL

SPECIFICATIONS

Wingspan:	72 in [1830mm]	Weight:	12.75– 13.75 lb [5780–6230 g]	Length:	56.5 in [1435mm]
Wing Area:	1384 in ² [89.2 dm ²]	Wing Loading:	21– 23 oz/ft ² [64– 70 g/dm ²]	Radio:	4-Channel with 7 std servos
				Engine:	.91 cu in [15cc] 2-stroke 1.20 cu in [20cc] 4-stroke 25-30cc gas

WARRANTY

Great Planes® Model Manufacturing Co. guarantees this kit to be free from defects in both material and workmanship at the date of purchase. This warranty does not cover any component parts damaged by use or modification. **In no case shall Great Planes' liability exceed the original cost of the purchased kit.** Further, Great Planes reserves the right to change or modify this warranty without notice.

In that Great Planes has no control over the final assembly or material used for final assembly, no liability shall be assumed nor accepted for any damage resulting from the use by the user of the final user-assembled product. By the act of using the user-assembled product, the user accepts all resulting liability.

If the buyer is not prepared to accept the liability associated with the use of this product, the buyer is advised to return

this kit immediately in new and unused condition to the place of purchase.

To make a warranty claim send the defective part or item to Hobby Services at the address below:

Hobby Services
3002 N. Apollo Dr. Suite 1
Champaign IL 61822 USA

Include a letter stating your name, return shipping address, as much contact information as possible (daytime telephone number, fax number, e-mail address), a detailed description of the problem and a photocopy of the purchase receipt. Upon receipt of the package the problem will be evaluated as quickly as possible.

READ THROUGH THIS MANUAL BEFORE STARTING CONSTRUCTION. IT CONTAINS IMPORTANT INSTRUCTIONS AND WARNINGS CONCERNING THE ASSEMBLY AND USE OF THIS MODEL.



Champaign, Illinois
(217) 398-8970, Ext 5
airsupport@greatplanes.com

TABLE OF CONTENTS

INTRODUCTION	2
AMA	2
SAFETY PRECAUTIONS	2
DECISIONS YOU MUST MAKE	3
Glow Engine Option & Required Parts	3
Gasoline Engine Option & Required Parts	3
Radio System Recommendations	3
ADDITIONAL ITEMS REQUIRED	3
Adhesives & Building Supplies	3
Optional Supplies and Tools	4
IMPORTANT BUILDING NOTES	4
KIT INSPECTION	4
ORDERING REPLACEMENT PARTS	5
KIT CONTENTS	5
PREPARE FOR ASSEMBLY	6
WING ASSEMBLY	6
Aileron Servo Preparation	6
Bottom Wing Assembly	6
Top Wing Assembly	9
ASSEMBLE THE FUSELAGE	12
Main Landing Gear Installation	12
Cabane Strut Installation	13
Horizontal Stabilizer, Tailwheel & Rudder Installation	14
Pushrod, Control Horn & Servo Installation	16
GLOW ENGINE INSTALLATION	18
Mount the Engine	18
Hook up the Throttle	19
Install the Fuel Tank	21
GASOLINE ENGINE INSTALLATION	22
Mount the Engine	22
Hook up the Throttle	23
Install the Fuel Tank	24
Install the Ignition Unit	25
FINAL ASSEMBLY	26
Radio Installation	26
Cowl and Propeller Installation	28
Install the Wheel Pants and Fairings	31
Cockpit Options	32
Pilot Installation (Optional)	32
Finishing the Model	33
Apply the Decals	34
GET THE MODEL READY TO FLY	34
Check the Control Directions	34
Set the Control Throws	34
Balance the Model (C.G.)	35
Balance the Model Laterally	35
PREFLIGHT	36
Identify Your Model	36
Charge the Radio Batteries	36
Balance Propellers	36
Ground Check & Range Check	36
ENGINE SAFETY PRECAUTIONS	36
AMA SAFETY CODE	37
CHECK LIST	37
FLYING	38
Fuel Mixture Adjustments	38
Takeoff	38
Flight	38
Landing	38

INTRODUCTION

Thank you for purchasing the Great Planes Waco YMF-5 ARF! We offer two options for the builder of this classic model. Build it as a single seat mail carrier, or as a three seat civilian open cockpit biplane. You'll enjoy the great scale-like handling characteristics of this big biplane and the level of detail we've put into this model. This manual details the installation of both a glow and gas engine, so please look in the Decisions You Must Make section for the items required to complete each type of installation before you begin building.

For the latest technical updates or manual corrections to the Waco YMF-5 ARF visit the Great Planes web site at www.greatplanes.com. Open the "Airplanes" link, and then select the Waco YMF-5 ARF. If there is new technical information or changes to this model a "tech notice" box will appear in the upper left corner of the page.

AMA

Academy of Model Aeronautics: If you are not already a member of the AMA, please join! The AMA is the governing body of model aviation and membership provides liability insurance coverage, protects modelers' rights and interests and is required to fly at most R/C sites.



Academy of Model Aeronautics

5151 East Memorial Drive
Muncie, IN 47302-9252
Tele. (800) 435-9262
Fax (765) 741-0057
www.modelaircraft.org

IMPORTANT!!!

Two of the most important things you can do to preserve the radio controlled aircraft hobby are to avoid flying near full-scale aircraft and avoid flying near or over groups of people.

PROTECT YOUR MODEL, YOURSELF & OTHERS... FOLLOW THESE IMPORTANT SAFETY PRECAUTIONS

1. Your Waco YMF-5 should not be considered a toy, but rather a sophisticated, working model that functions very much like a full-size airplane. Because of its performance capabilities, the Waco YMF-5, if not assembled and operated correctly, could possibly cause injury to yourself or spectators and damage to property.

2. You must assemble the model **according to the instructions**. Do not alter or modify the model, as doing so may result in an unsafe or unflyable model. In a few cases the instructions may differ slightly from the photos. In those instances the written instructions should be considered as correct.

3. You must take time to **build straight, true and strong**.

4. You must use an R/C radio system that is in good condition, a correctly sized engine, and other components as specified in this instruction manual. All components must be correctly installed so that the model operates correctly on the ground and in the air. You must check the operation of the model and all components before **every** flight.

5. If you are not an experienced pilot or have not flown this type of model before, we recommend that you get the assistance of an experienced pilot in your R/C club for your first flights. If you're not a member of a club, your local hobby shop has information about clubs in your area whose membership includes experienced pilots.

6. While this kit has been flight tested to exceed normal use, if an engine larger than one in the recommended range is used, the modeler is responsible for taking steps to reinforce the high stress points and/or substituting hardware more suitable for the increased stress.

7. **WARNING:** The cowl, wheel pants, and some fairings are made of fiberglass, the fibers of which may cause eye, skin and respiratory tract irritation. Never blow into or on a part to remove fiberglass dust, as the dust will blow back into your eyes. Always wear safety goggles, a particle mask and rubber gloves when grinding, drilling and sanding fiberglass parts. Vacuum the parts and the work area thoroughly after working with fiberglass parts.

We, as the kit manufacturer, provide you with a top quality, thoroughly tested kit and instructions, but ultimately the quality and flyability of your finished model depends on how you build it; therefore, we cannot in any way guarantee the performance of your completed model, and no representations are expressed or implied as to the performance or safety of your completed model.

Remember: Take your time and follow the instructions to end up with a well-built model that is straight and true.

DECISIONS YOU MUST MAKE

This is a partial list of items required to finish the Waco YMF-5 that may require planning or decision making before starting to build. Order numbers are provided in parentheses.

Glow Engine Option & Required Parts

If you choose to equip your model with a glow engine, you will need to purchase the items listed below. Either a two-stroke or a four-stroke engine can be used. This manual will show the installation of an O.S. 1.20 four-stroke engine.

- 3' [900mm] standard silicone fuel tubing (GPMQ4131)
- Suitable propeller per engine manufacturer's recommendation
- O.S.® Needle Valve Extension kit (optional) (OSMG7290)

Two-Stroke Option

- O.S. .95 AX Ringed 2-Stroke engine (OSMG0580)
- Bisson Pitts muffler (BISG4091)

Four-Stroke Option

- O.S. FS-120S-E Surpass™ Ringed 4-Stroke engine (OSMG0930)

Gas Engine Option & Required Parts

To equip your Waco with a gasoline engine, we recommend the DLE-30 gas engine for its power, reliability, and economy. Regardless of the gas engine you choose, you will also need to purchase a few other items to set up your model for gasoline fuel.

- DL Engines™ DLE-30cc Gas Engine (DLEG0031)
- Sullivan Gasoline Tank Conversion Kit (SULQ2684)
- Dubro 1/8" Fuel Line Barbs (DUBQ0670)
- Dubro 1/8" ID Tygon Fuel Tubing (DUBQ0493)
- Fuel Line Clamps 1/8" (GPMQ4172)
- Ernst Charge Jack Receptacle (ERNM3001)
- Futaba® NR4RB 4.8V 1000mAh NiCd Receiver Battery (FUTM1380)
- Futaba J-Series Switch w/ Charge Plug (FUTM4370)
- (4) 10-32 or M5 bolts, blind nuts, washers, & lock washers for engine mounts
- (4) M4 x 20mm machine screws for cowl installation tool

Radio System Recommendations

- 4 Channel Radio System (computer radio with mixing preferred)
- Futaba R617FS 7-Channel 2.4GHz Receiver (FUTL7627)
- (1) Futaba S3004 Standard Ball Bearing Servo (FUTM0004)
- (6) Futaba S9001 Coreless Ball Bearing Servo (FUTM0075)
- Futaba NR4RB 4.8V 1000mAh NiCd Receiver Battery (FUTM1380)
- (2) 16" [405mm] servo extension (FUTM3955)
- (1) 12" [300mm] servo extension (HCAM2711)
- (1) 30" [760mm] servo extension (EMOM0129)
- (1) 21" [533mm] Y-harness (HCAM2500)
- (1x or 2x if no computer radio) 6" [152mm] Y-harness (FUTM4130)
- Futaba J-Series Switch w/ Charge Plug (FUTM4370)
- Switch & Charge Jack Mounting Set (GPMM1000)

ADDITIONAL ITEMS REQUIRED

Required Hardware and Accessories

To finish this airplane you will need the following items.

- (2) 3/8" x 3" Heat Shrink Tubing (DUBM2180)
- R/C foam rubber 1/4" [6mm] thick (HCAQ1000)
- Drill bits: 1/16" [1.6mm], 5/64" [2mm], 3/32" [2.4mm], 1/8" [3.2mm], 1/4" [6.4mm], 13/32" [10mm], 3/16" [4.8mm] long drill bit

- 1 oz. [30g] Medium Pro™ CA+ (GPMR6008)
- 1 oz. [30g] Thin Pro CA (GPMR6002)
- CA applicator tips (HCAR3780)
- CA debonder (GPMR6039)
- Pro 30-minute epoxy (GPMR6047)
- Pro 6-minute epoxy (GPMR6045)
- Epoxy brushes (6, GPMR8060)
- Mixing sticks (50, GPMR8055)
- Mixing cups (GPMR8056)
- Threadlocker™ thread-locking compound (GPMR6060)
- R/C-56 canopy glue 4oz (JOZR5007)
- Medium T-pins (100, HCAR5150)
- #64 rubber bands (1/4 lb [113g] box, HCAQ2020)
- Milled fiberglass (GPMR6165)
- 18" flexible steel rule (HCAR0460)
- Builder's Triangle Set (HCAR0480)
- 2-56 tap and drill set (GPMR8100)
- 6-32 tap and drill set (GPMR8102)
- Tap handle (GPMR8120)
- Pliers with wire cutter (HCAR0625)
- Hobbico® Heavy Duty Diagonal Cutter 7" (HCAR0627)
- Electric drill
- Household scissors
- Hobbico ball-end hex wrench set – metric (HCAR0521)
- Hobbico ball-end hex wrench set – SAE (HCAR0520)
- (2) 1" [25mm] C-Clamps
- Excel Small Clamp (EXLR5663)
- Easy-Touch™ Bar Sander 5.5" (GPMR6169)
- Sandpaper assortment
- Masking tape
- Denatured alcohol (for epoxy clean up)
- Paper towels
- Plan protector (GPMR6167) or wax paper

Optional Supplies and Tools

- 21st Century® sealing iron (COVR2700)
- 21st Century iron cover (COVR2702)
- Rotary tool such as Dremel®
- Rotary tool reinforced cut-off wheel (GPMR8200)
- Dremel Drum Sander, Coarse 3/8" (DRER0968)
- Hobbico Retractable Fabric Tape Measure (HCAR0478)
- Hobbico Z-bend pliers (HCAR2000)
- Hobby Heat™ micro torch (HCAR0755)
- Panel Line Pen (TOPQ2510)
- Dead Center™ Engine Mount Hole Locator (GPMR8130)
- AccuThrow™ Deflection Gauge (GPMR2405)
- Precision Magnetic Prop Balancer (TOPQ5700)
- Great Planes 1/5th scale WWI German Pilot (brown) (GPMQ9115)
- Hobbico Pin Vise 1/16" Collet w/3 Bits (HCAR0696)
- Great Planes E-Z Mask Tape 1/8" (GPMR1000)

IMPORTANT BUILDING NOTES

- When you see the term **test fit** in the instructions, it means that you should first position the part on the assembly **without using any glue**, and then slightly modify or *custom fit* the part as necessary for the best fit.
- Whenever the term **glue** is written you should rely upon your experience to decide what type of glue to use. When a specific type of adhesive works best for that step, the instructions will make a recommendation.
- Whenever just **epoxy** is specified you may use **either** 30-minute (or 45-minute) epoxy **or** 6-minute epoxy. When 30-minute epoxy is specified it is **highly** recommended that you use only 30-minute (or 45-minute) epoxy, because you will need the working time and/or the additional strength.
- **Photos** and **sketches** are placed **before** the step they refer to. Frequently you can study photos in following steps to get another view of the same parts.
- The Waco YMF-5 is factory-covered with Top Flite® MonoKote® film. Should repairs ever be required, MonoKote can be patched with additional MonoKote purchased separately. MonoKote is packaged in six-foot rolls, but some hobby shops also sell it by the foot. If only a small piece of MonoKote is needed for a minor patch, perhaps a fellow modeler would give you some. MonoKote is applied with a model airplane covering iron, but in an emergency a regular iron could be used. A roll of MonoKote includes full instructions for application. Following are the colors used on this model and order numbers for six foot rolls.

Cub Yellow (TOPQ0220)

Black (TOPQ0208)

True Red (TOPQ0227)

- The stabilizer and wing incidences and engine thrust angles have been factory-built into this model. However, some technically-minded modelers may wish to check these measurements anyway. To view this information visit the web site at www.greatplanes.com and click on "Technical Data." Due to manufacturing tolerances which will have little or no effect on the way your model will fly, please expect slight deviations between your model and the published values.

KIT INSPECTION

Before starting to build, take an inventory of this kit to make sure it is complete, and inspect the parts to make sure they are of acceptable quality. If any parts are missing or are not of acceptable quality, or if you need assistance with assembly, contact Product Support. When reporting defective or missing parts, use the part names exactly as they are written in the Kit Contents list.

Great Planes Product Support:

3002 N Apollo Drive, Suite 1

Champaign, IL 61822

Telephone: (217) 398-8970, ext. 5

Fax: (217) 398-7721

E-mail: airsupport@greatplanes.com

ORDERING REPLACEMENT PARTS

Replacement parts for the Waco YMF-5 ARF are available using the order numbers in the Replacement Parts List that follows. The fastest, most economical service can be provided by your hobby dealer or mail-order company.

To locate a hobby dealer, visit the Great Planes web site at www.greatplanes.com. Choose "Where to Buy" at the bottom of the menu on the left side of the page. Follow the instructions provided on the page to locate a U.S., Canadian or International dealer.

Parts may also be ordered directly from Hobby Services by calling (217) 398-0007, or fax at (217) 398-7721, but full retail prices and shipping and handling charges will apply. Illinois and Nevada residents will also be charged sales tax. If ordering via fax, include a Visa® or MasterCard® number and expiration date for payment.

Mail parts orders and payments by personal check to:

Hobby Services
3002 N. Apollo Drive, Suite 1
Champaign, IL 61822

Be certain to specify the order number exactly as listed in the **Replacement Parts List**. Payment by credit card or personal check only; no C.O.D.

If additional assistance is required for any reason, contact Product Support by telephone at (217) 398-8970, or by e-mail at productsupport@greatplanes.com.

REPLACEMENT PARTS LIST

Order No.	Description
GPMA4065	Fuselage Set
GPMA4066	Top Wing Set
GPMA4067	Bottom Wing Set
GPMA4068	Cabane Set
GPMA4069	Interplane Struts Set
GPMA4070	Landing Gear Set
GPMA4071	Wheel Pants
GPMA4072	Rudder Set
GPMA4073	Horizontal Stab Set
GPMA4074	Tailwheel Set
GPMA4075	Windscreens Set
GPMA4076	Cowl Set
GPMA4077	Decal Sheet
GPMA4078	Bottom Wing Cover
GPMA4079	Cowl Ring Set

NOTE ►	Full-size plans are not available. You can download a copy of this manual at www.greatplanes.com .
---------------	---

KIT CONTENTS

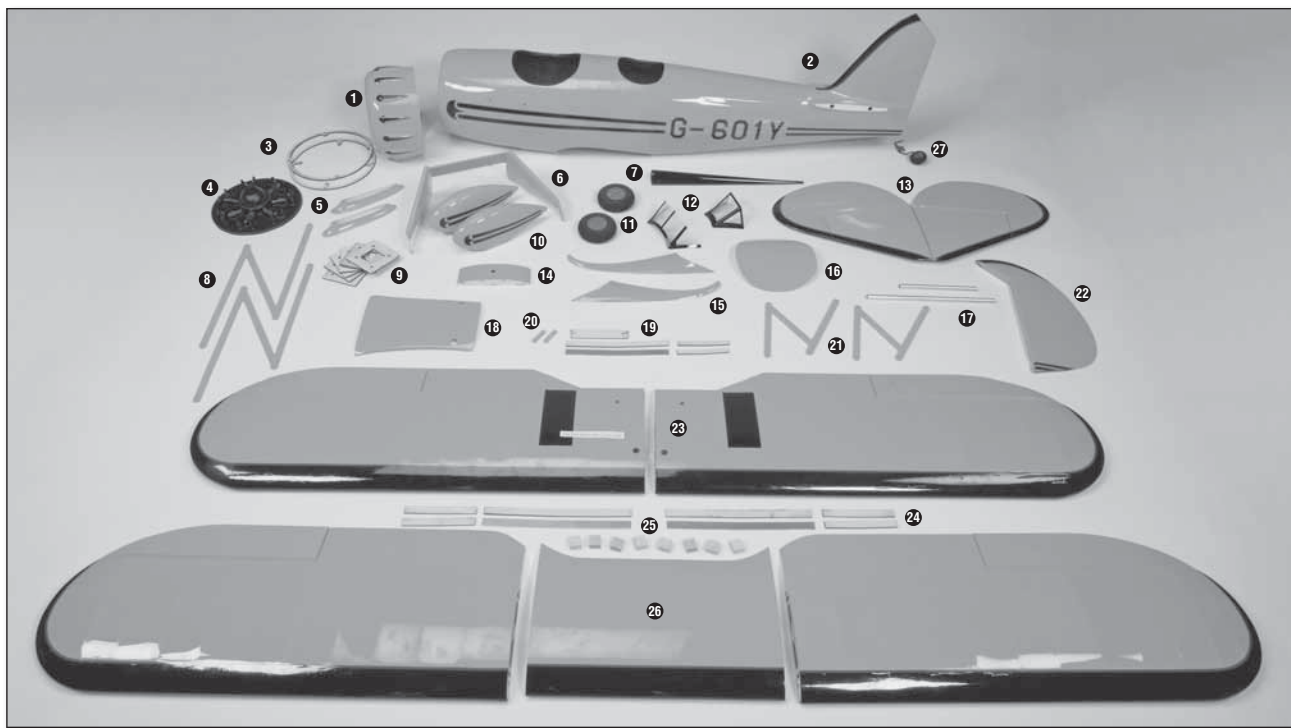

- | | | | |
|--------------------------|---------------------------------|---------------------------|---------------------------|
| 1. Cowl | 8. Interplane Struts | 15. Wing Fillet Fairings | 22. Rudder |
| 2. Fuselage | 9. Engine Spacers | 16. Front Cockpit Cover | 23. Lower Wing |
| 3. Cowl Rings | 10. Wheel Pants | 17. Horizontal Stab Tubes | 24. Upper Wing Joiners |
| 4. Dummy Engine | 11. Wheels | 18. Belly Fairing | 25. Servo Mounting Blocks |
| 5. Landing Gear Fairings | 12. Windscreens | 19. Lower Wing Joiners | 26. Upper Wing |
| 6. Main Landing Gear | 13. Horizontal Tail | 20. Wing Dowels | 27. Tailwheel Assembly |
| 7. Turtledeck Fairing | 14. Landing Gear Center Fairing | 21. Cabane Struts | |

PREPARE FOR ASSEMBLY



Before you begin assembling your model, use a covering iron set to a medium temperature (about 250° F [121° C]) to tack down any loose or wrinkled covering. Securely tack down the edges of trim and where seams are present and around the aileron servo hatch covers. We recommend using a Coverite™ (COVR2700) covering iron with a sock (COVR2702).

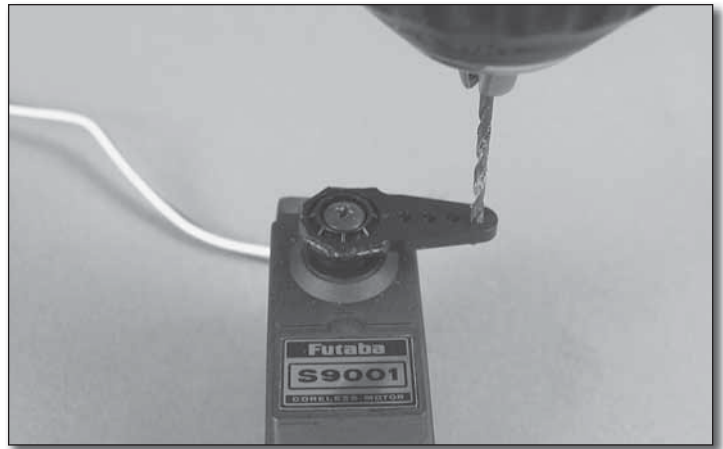

□ 2. Use a 5/64" [2mm] drill bit to drill the outermost servo arm hole on all four aileron servos.

WING ASSEMBLY

Aileron Servo Preparation

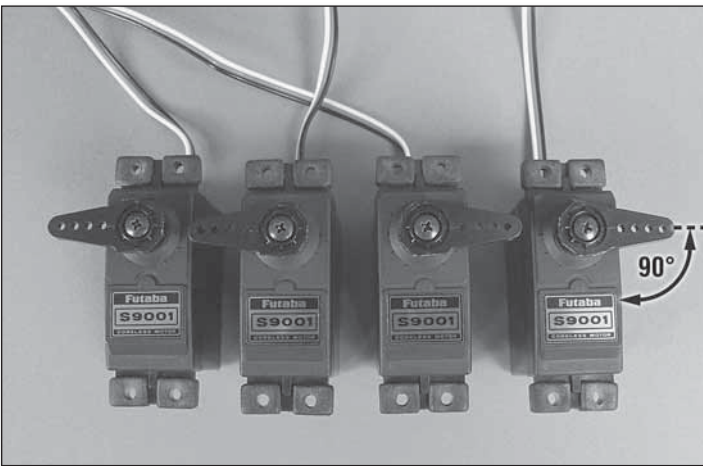

□ 1. Locate the long servo arm that came with your servo. For Futaba standard servos this is the arm that is already installed on the servo. For other radio systems, please use the arm that is at least 5/8" [15.9mm] long from the center of the shaft to the outermost hole. Center four servos using your radio. Remove the servo arm screw and reposition the servo arm on the splined output shaft so that the arm is 90° (perpendicular) to the servo case side. Clip off the unused servo arms so that your servos look like those in the photo. Install the servo arm screw.

Bottom Wing Assembly

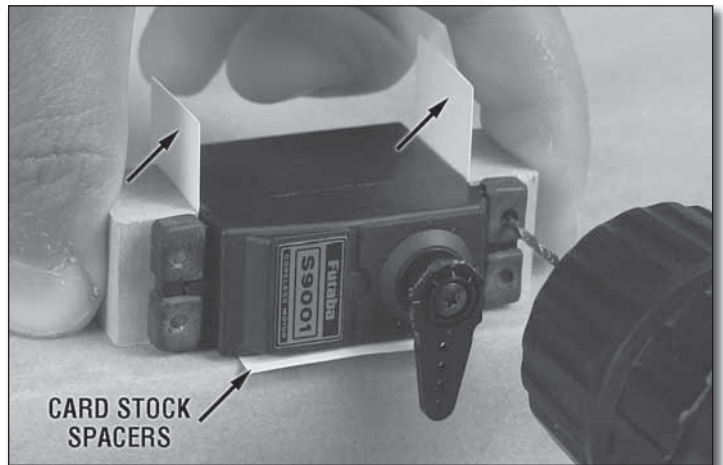

□ □ 1. Working with the bottom left wing now, cut out three 1/2" x 1" [13mm x 25mm] pieces of thin card stock (not supplied). You may use construction paper or a manila folder for this purpose. Lay the servo on a flat surface with the arm hanging down over the edge of your table. Locate two 19x19x9mm hardwood blocks. Position the blocks under the servo mounting tabs and place a piece of card stock in the locations shown. Holding the blocks and servo in position, use a 1/16" [1.6mm] drill to drill four holes for the servo mounting screws.

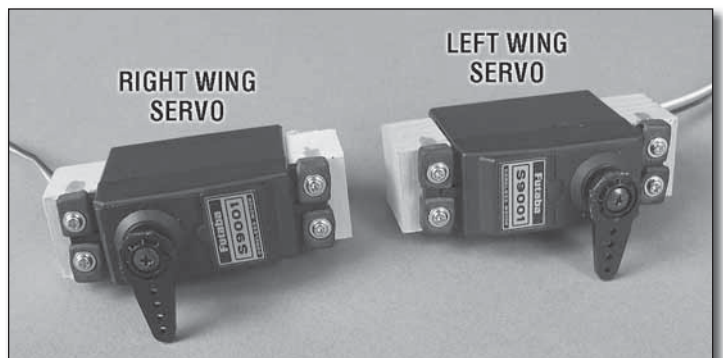

□ □ 2. Install the four servo mounting screws that came with your servo. Remove the screws and harden each of the

screw holes with thin CA. Let the CA cure and reinstall the screws. Remember that you are going to set up a left side servo and a right side servo.

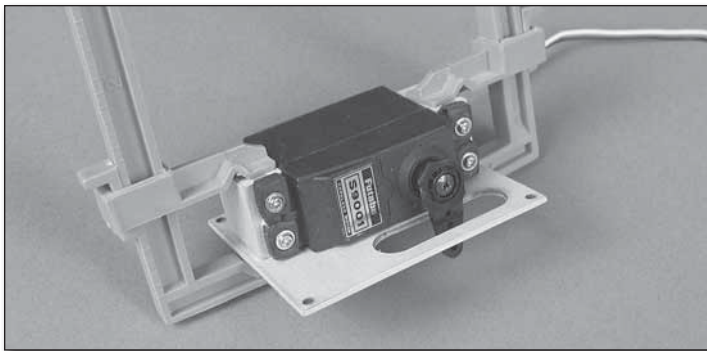

❑❑ 3. With the hardwood blocks attached and each servo arm still centered, position your servo on the aileron servo bay cover so that the servo arm is centered in the opening. Glue these in place and hold the blocks to the servo bay cover with two small clamps. The clamps shown here are Excel 3-1/2" [89mm] plastic clamps (EXLR5663). Let the glue cure.

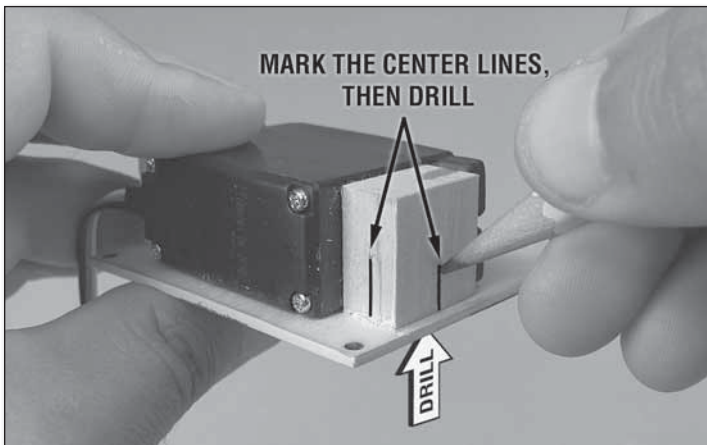

❑❑ 4. Mark the approximate center line of each block on both the wide side and the narrow side of each mounting block. Using a 1/16" [1.6mm] drill bit, drill one hole into each block by drilling through the servo bay cover and into the block. Sighting from the back and from the side, line up the drill with the marks you made on the blocks.

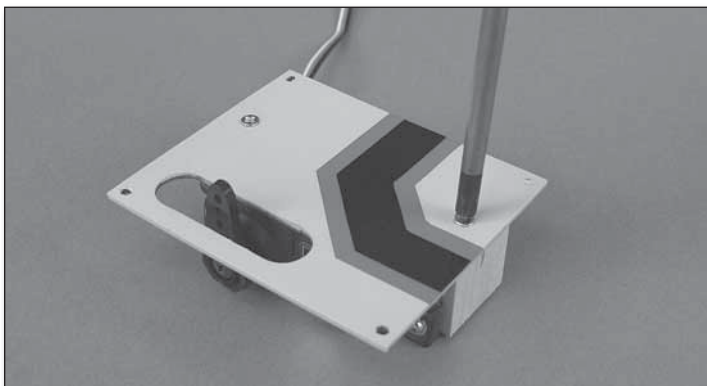

❑❑ 5. Install one #2 x 3/8" [9.5mm] countersunk sheet metal screw into each block. Remove the screws and harden the holes you just tapped with a drop of thin CA.

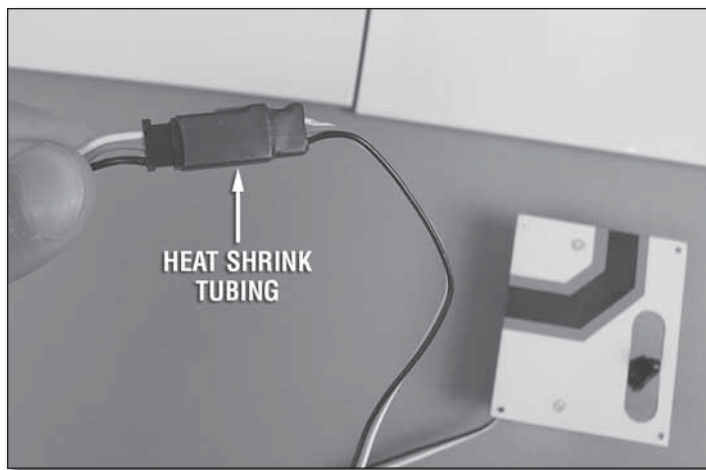

❑❑ 6. Attach a 16" [405mm] servo lead extension to the aileron servo lead. Use a piece of 3/8" [9.5mm] diameter heat shrink tubing (not supplied) to secure the connection or simply tape the connectors to secure them. Route the servo lead through each wing using the supplied guide string.



❑❑ 7. Route the other end of the servo lead through the hole in the top side of the wing.



❑❑ 8. Note the orientation of the servo bay cover in the photo above. Position the completed servo bay cover properly and install it to the wing using four #2 x 3/8" [9.5mm] sheet metal screws and four #2 flat washers. Remove the screws and servo bay covers and harden the screw holes with a drop of thin CA.

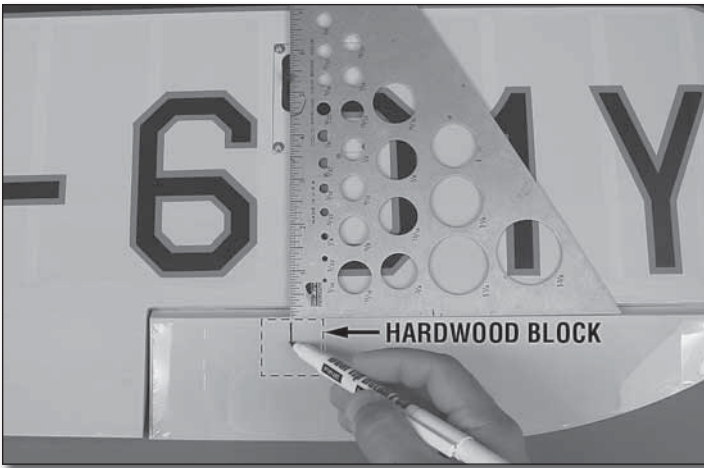

□ □ 9. Using a 90° builder's square or triangle, draw a 1/2" [12.7mm] long line on the aileron straight back from the servo arm. Take note of the hardwood block that is below the surface of the covering. You will drill into this block next.

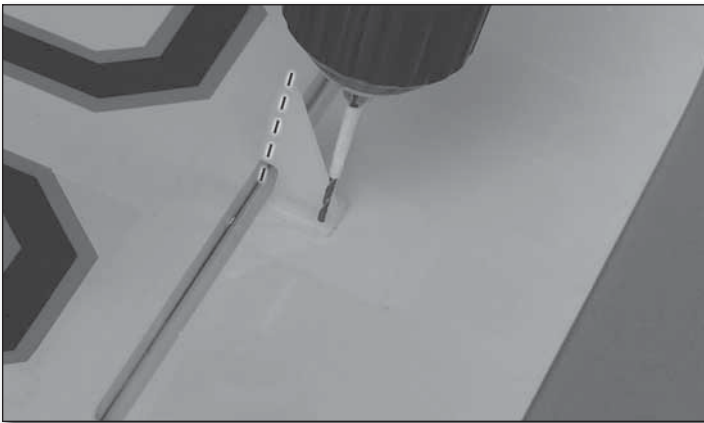

□ □ 10. Center a large nylon control horn over the line you drew so that the pushrod holes in the horn are directly over the hinge line of the aileron. With a 1/16" [1.6mm] drill bit, hold the horn in place and drill two 1/2" [12.7mm] deep holes using the holes in the horn as a guide. **Be careful not to drill all the way through the aileron.** Wrap a piece of masking tape around your drill bit 1/2" [12.7mm] from the tip to help you know how deep to drill.

□ □ 11. Install the control horn using two #2 x 1/2" [12.7mm] sheet metal screws. Remove the screws and the horn and harden the screw threads you created with a few drops of thin CA. Reinstall the control horn.

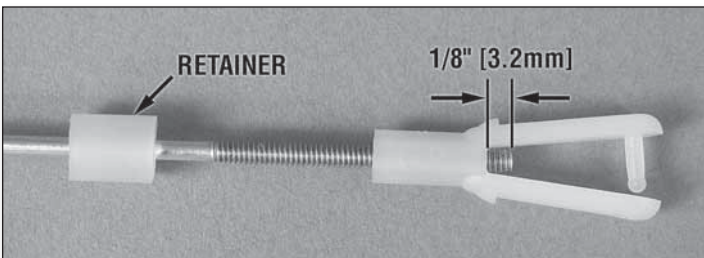

□ □ 12. Fit a nylon clevis to a 12" [305mm] one-end threaded pushrod so that the end of the threaded rod extends 1/8" [3.2mm] into the clevis barrel. Fit a silicone retainer onto the pushrod as shown.

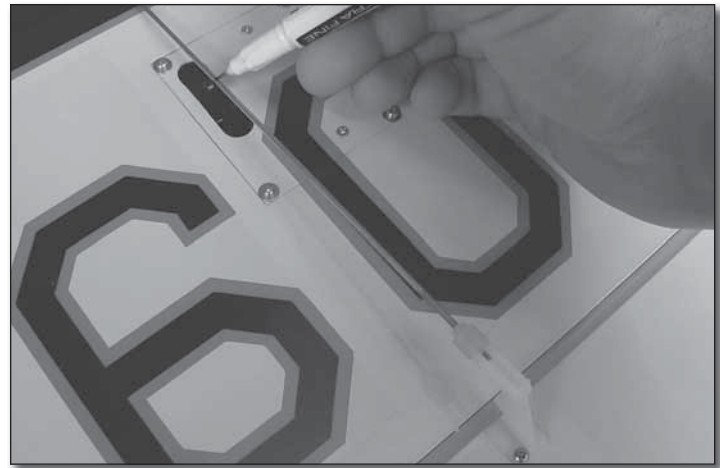

□ □ 13. Fit the clevis to the outer hole of the control horn. With the aileron servo and the aileron centered, mark the bend line at the outer hole in the servo arm.

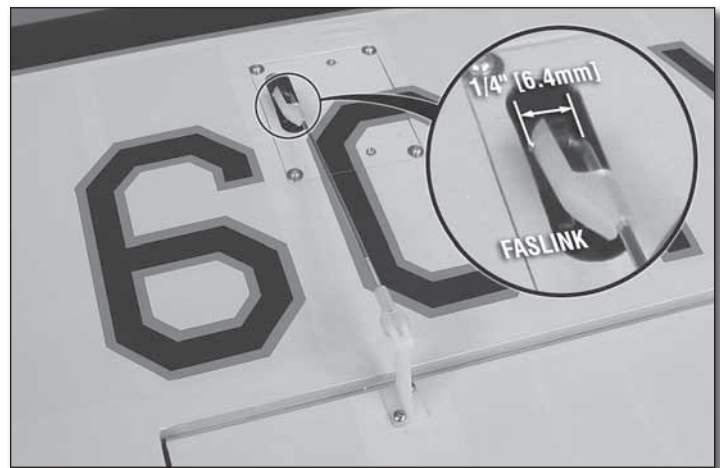

□ □ 14. Bend the pushrod wire 90°. Clip off the excess wire so that the bent section is at least 1/4" [6.4mm] long. Connect the wire in the outer hole of the servo arm and fit a nylon Faslink™ to hold it in place. Make any fine adjustments by removing the clevis from the control horn and turning it in or out to shorten or lengthen the pushrod. Slide the silicone retainer in place over the arms of the clevis.

□ 15. Repeat steps 1 through 14 for the bottom right wing.

□ 16. For the next few steps, cut up some paper towels into 1/4 sheets and have some denatured alcohol on hand to clean up any epoxy.

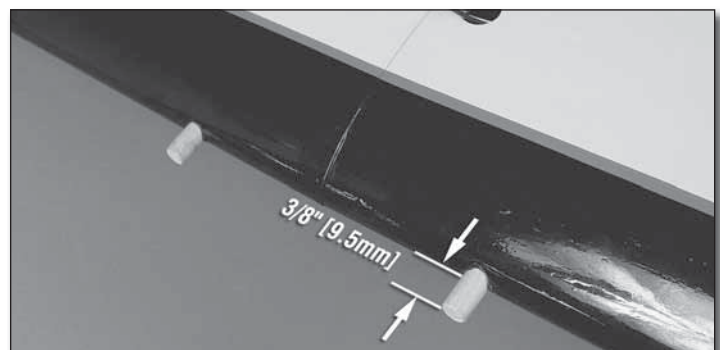

□ 17. Epoxy the two 37mm x 8mm wing dowels in place so that at least 3/8" [9.5mm] of each dowel extends forward from the leading edge.

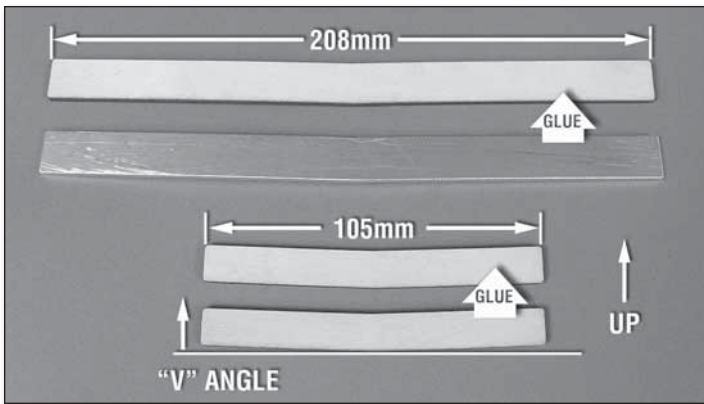

□ 18. Identify the two 208mm x 15mm bottom wing L.E. joiners. One is made out of aluminum and one is wood. Identify the two 105mm x 12mm bottom wing T.E. joiners. Using 180-grit sandpaper, scuff the side of the aluminum joiner that will be glued to the wood joiner. Clean the aluminum joiner with an alcohol-dampened cloth. Mix up a batch of 30-minute epoxy and coat the faces of each joiner. Glue the two L.E. joiners together and the two T.E. joiners together so that you now have one long and one short joiner. Take note of the dihedral "V" angle in the joiners. Align the pieces and clamp them together. Let the epoxy cure. Then, remove the clamps.

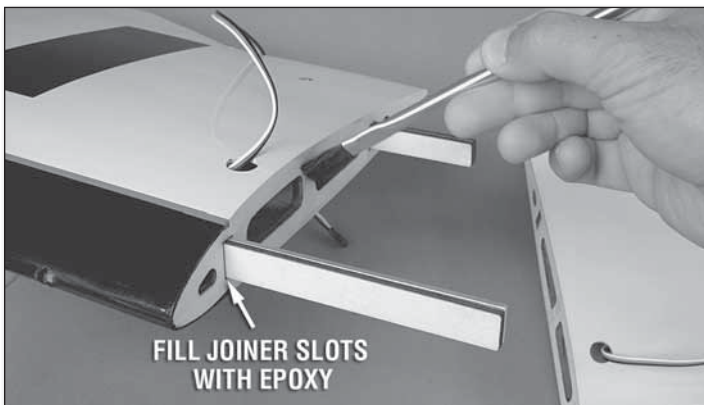

□ 18. Orient the wings so that they are both facing up. Apply some 30-minute epoxy into the L.E. and T.E. joiner slots. Apply epoxy to both sides of each joiner. Fit the long L.E. joiner into the L.E. slot so the "V" in the joiner is upright. Fit the short T.E. joiner into the T.E. slot the same way. Thoroughly coat the root rib of both wings with epoxy and fit the wings together.

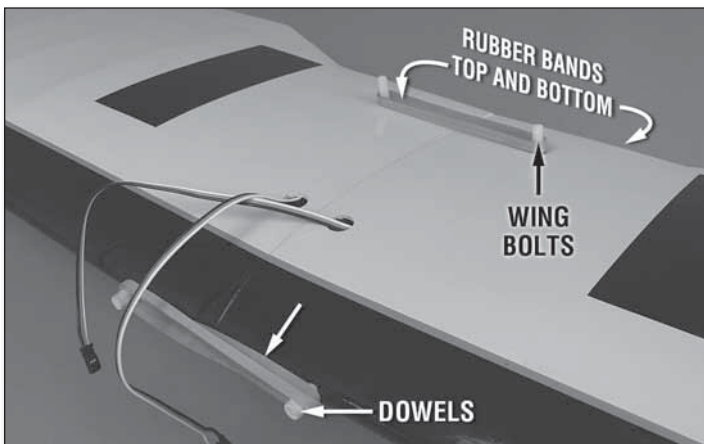

□ 20. Fit the two 1/4-20 x 2" nylon wing bolts and use some #64 rubber bands to hold the wings together while the epoxy

cures. Use three rubber bands on the dowels to hold the L.E. together. Put two rubber bands on the top side of the wing and two on the bottom side with the bolts half way through the holes.

□ 21. Use paper towels and some denatured alcohol to clean up any excess epoxy that is squeezed out of the joint. Allow the epoxy to fully cure.

Top Wing Assembly

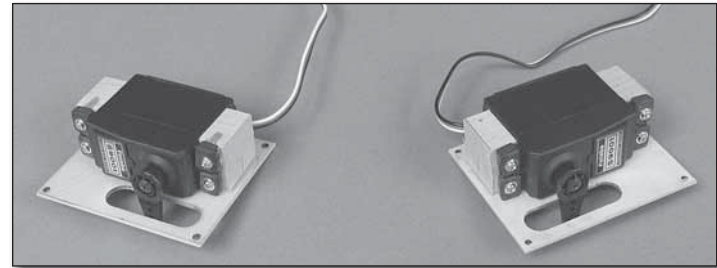

□ 1. Prepare a left and a right servo and fit each one to its respective servo bay cover as you did for the lower wing.

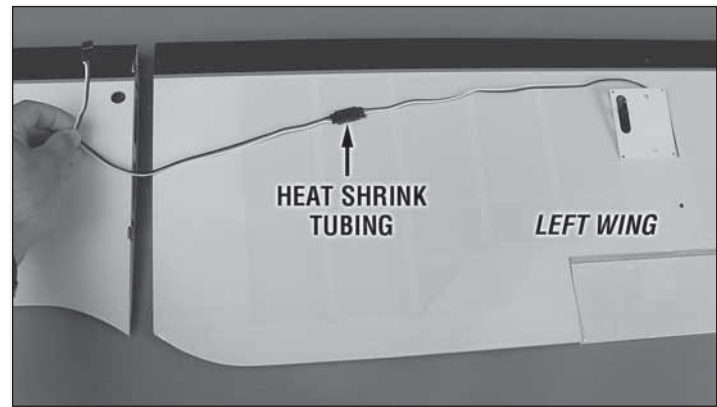

□ 2. Connect a 12" [300mm] servo lead extension to the left wing servo. Because of the hole in the center wing panel, the left wing servo will use a shorter servo lead extension. Use some 3/8" [9.5mm] heat shrink tubing or tape to secure the connector.

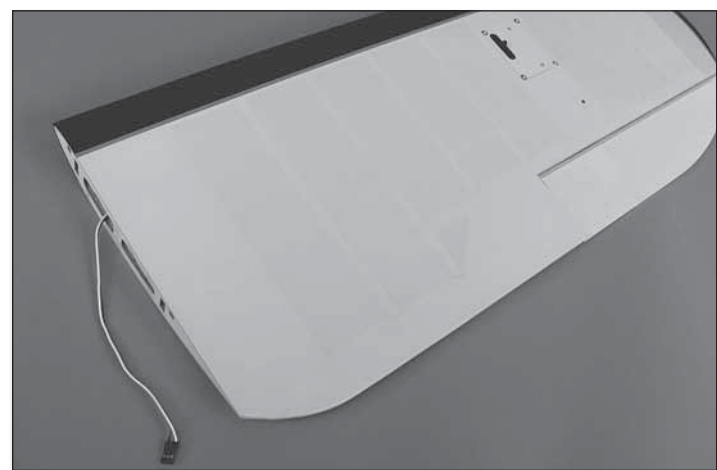

□ 3. Route the servo lead through the left wing and install the servo bay cover using four #2 x 3/8" [9.5mm] sheet metal screws and four #2 flat washers. Harden the screw holes with thin CA.

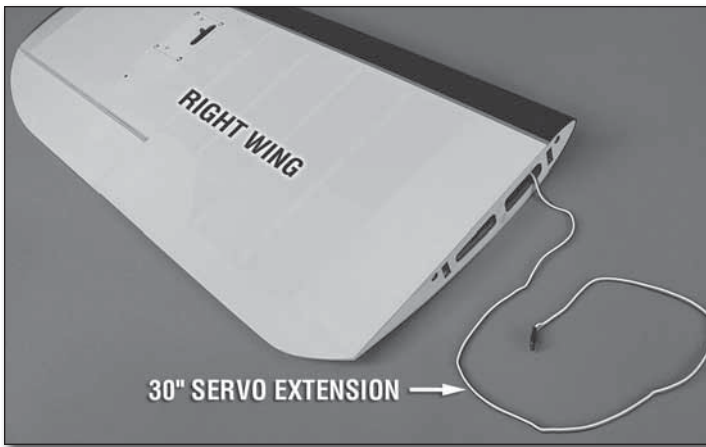

pushrod wire leaving 1/4" [6.4mm] of wire and fit the pushrod to the outer hole of the servo arm. Secure the pushrod at the servo arm with a nylon Faslink. Adjust the pushrod length at the clevis. Secure the clevis with the silicone retainer.

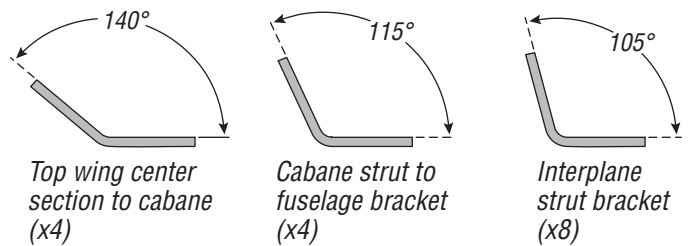

❑ 4. Connect a 30" [760mm] servo lead extension to the right wing servo. Secure the connection with heat shrink tubing or tape. Route the servo lead through the wing and install the servo bay cover using four #2 x 3/8" [9.5mm] sheet metal screws and four #2 flat washers.

❑ 8. Identify the bag of four steel brackets for the top wing center section. These are the brackets that have the 140° bend angle (or the brackets with the flattest bend).

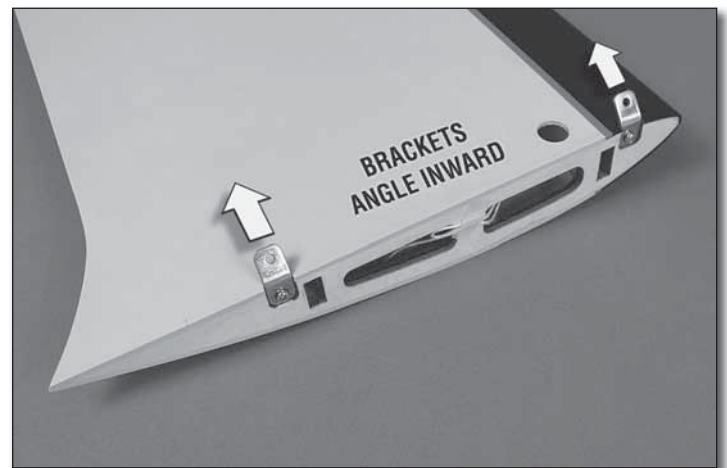
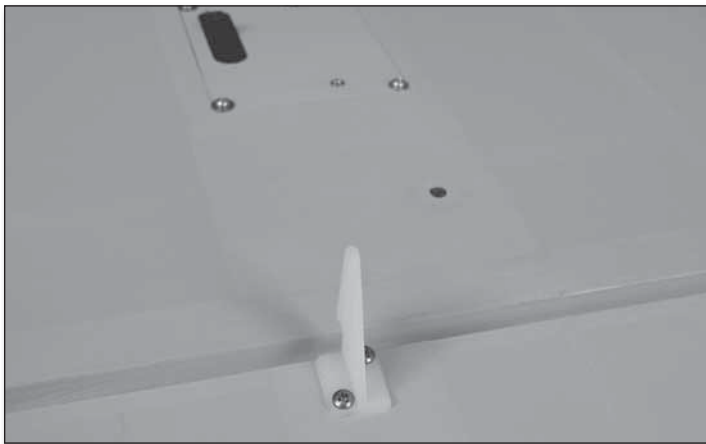

❑ 5. Line up and install the aileron control horns using the same method recommended earlier for the bottom wing. Drill two 1/2" [12.7mm] deep holes using a 1/16" [1.6mm] drill. Install the horns with two #2 x 1/2" [12.7mm] sheet metal screws per horn.

❑ 9. Use four #4 x 1/2" [12.7mm] sheet metal screws to attach the brackets to the wing center section in the orientation shown so that they are angled inward toward the fuselage center line. Remove the screws and brackets and harden the screw holes with thin CA. Reinstall the brackets.

❑ 6. Prepare two 12" [305mm] one-end threaded pushrods using two clevises and two silicone retainers.

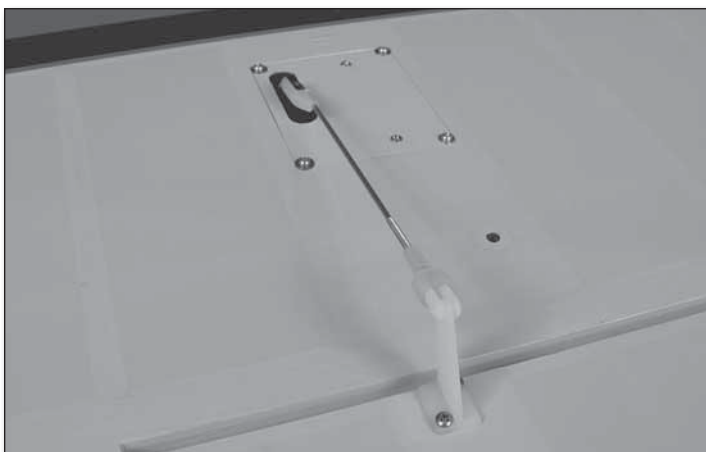

❑ 7. Fit the clevis to the outer hole in the control horn. Mark and bend the rod as you did earlier. Clip off the excess

❑ 10. Attach the guide string in the wing center section to the long servo extension of the right wing aileron servo. Pull the servo lead through the center section and route the lead through the hole in the front left corner of the bottom of the center section. Leave the guide string attached until after you have glued together the wings.

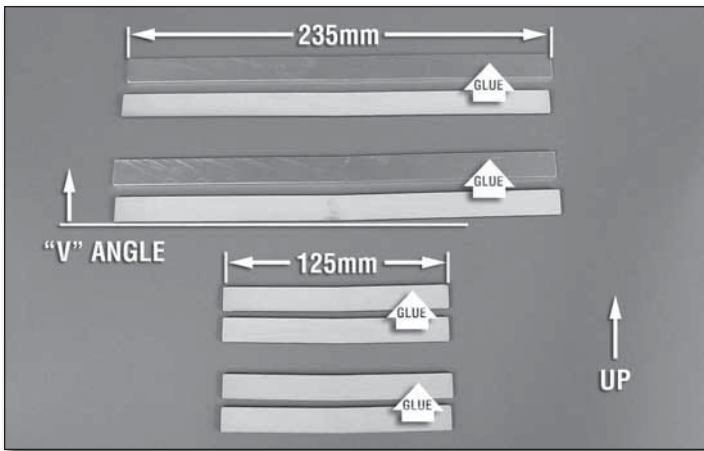

□ 11. Two joiners are needed to join the top left wing to the center wing section and two joiners are needed to join the right wing to the center section. Scuff and clean the aluminum joiner the same as was done for the bottom wing. Mix up a batch of 30-minute epoxy and glue each 235mm x 15mm aluminum L.E. joiner to a matching ply joiner. Be careful when matching the dihedral angle of the joiners when you're gluing them together because the angle is very shallow. Clamp these together and allow the epoxy to cure.

□ 12. Glue a pair of 125mm x 13mm plywood T.E. wing joiners together. Then, glue the remaining pair of 125mm x 13mm ply joiners to each other. Clamp these together and allow the epoxy to cure.

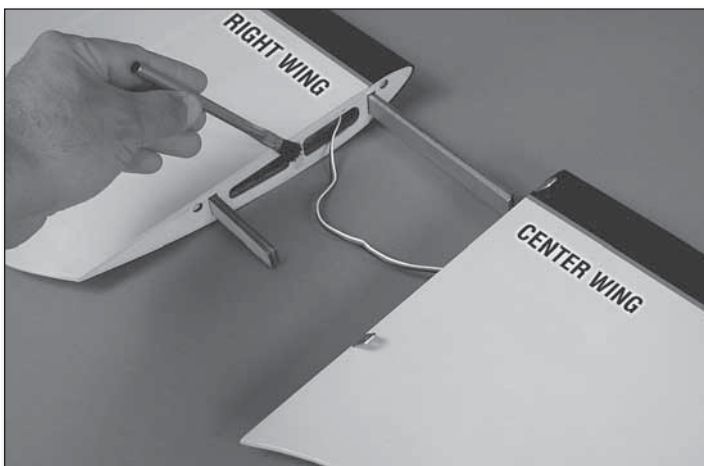

□ 13. Apply some epoxy into the L.E. and T.E. joiner slots of both the right wing and the right side of the center section. Coat the joiners with epoxy. Then, fit the long L.E. joiner into the leading edge slot and the short T.E. joiner into the trailing edge slot. Coat the root ribs of the right wing and the right side of the center section and join the right wing to the center section. Make sure you orient the joiners correctly with the dihedral angle upright. **Note:** To protect the servo lead contacts, wrap the connector in masking tape.

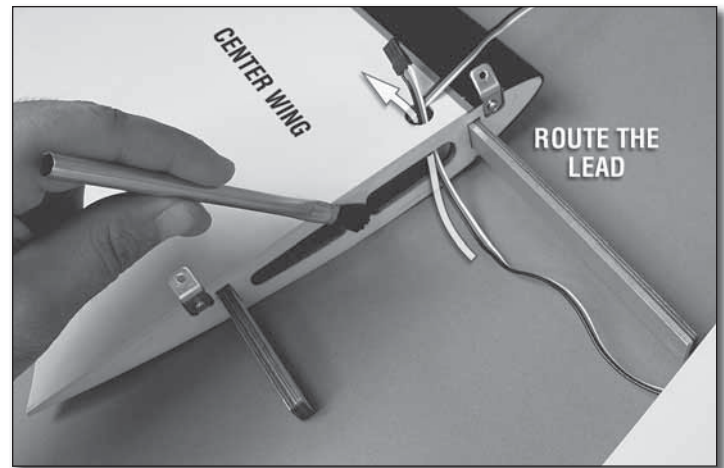

□ 14. Do the same for the left wing, coating the joiners and ribs with epoxy. When you're ready to slide the left wing onto the center section, route the servo lead through the root rib of the center section and out of the exit hole.

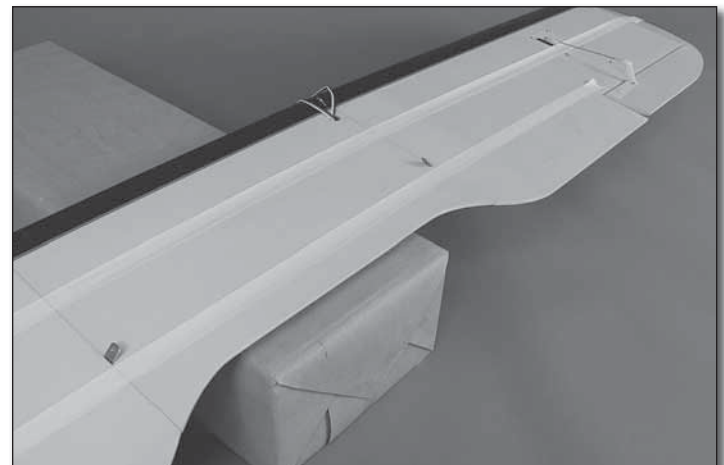

□ 15. Slide the wings together tightly. Hold them together using masking tape. Stretch one long piece across the span so the ends wrap around the wing tips. Do this for the top and the bottom side of the wing to ensure that the tape does not slip.

□ 16. Clean up any excess epoxy with denatured alcohol and paper towels. Set the wing aside and let the epoxy cure. Carefully remove the masking tape.

ASSEMBLE THE FUSELAGE

Main Landing Gear Installation

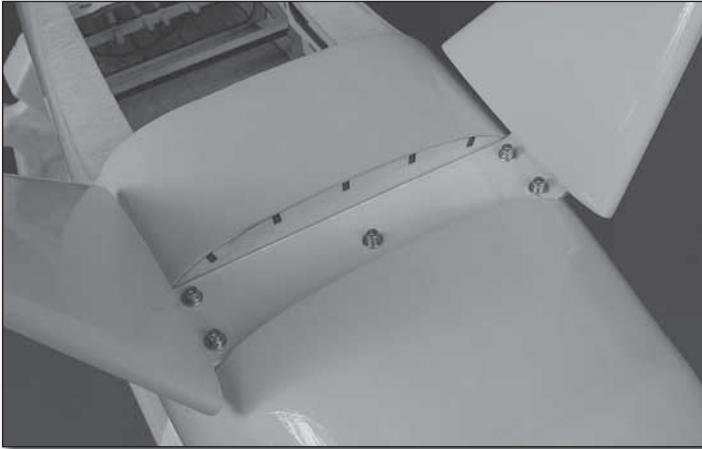

❑ 1. Install the main landing gear onto the fuselage using five 6-32 x 3/4" [19.1mm] SHCS, five #6 split lock washers, and five #6 flat washers. Use a drop of thread locking compound on the screw threads.

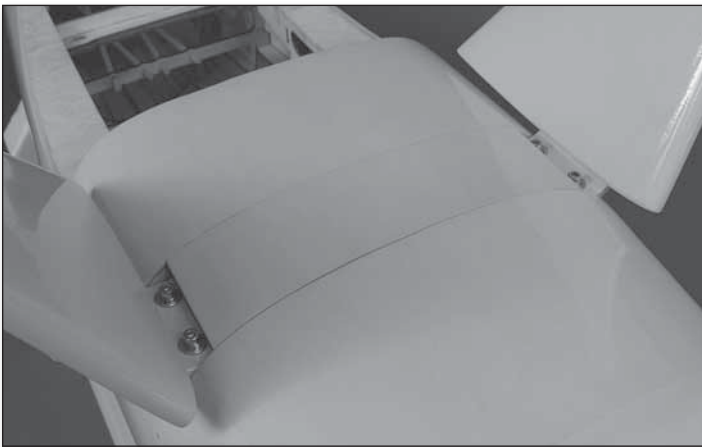

❑ 2. Install the main landing gear center fairing. Apply glue to the base of the fairing or the bottom of the aluminum gear strap. **Note:** The center fairing is not symmetrical, so please note the contours of the fairing and install it so that it matches the fuselage. (If you need to remove the landing gear in the future, trim away the covering over the access hole.)

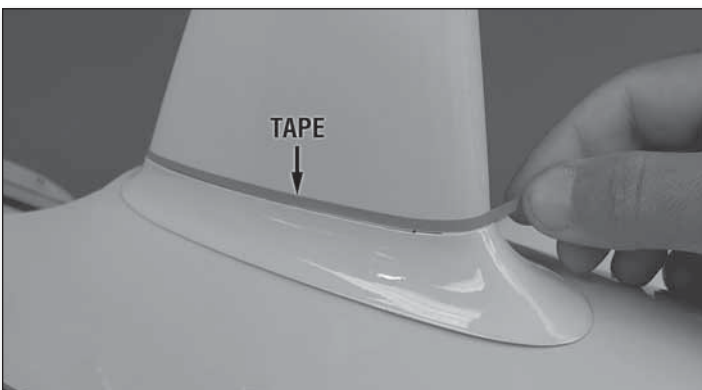

❑ 3. Test fit the gear to fuse fairings. **Note:** There is a left and right fairing. The smaller radius side of each fairing faces

inside. With the fairings up against the fuselage, wrap some 1/8" EZ-Mask tape (GPMR1000) or a narrow strip of regular masking tape about 1/16" [1.6mm] above the bottom edge of each fairing.

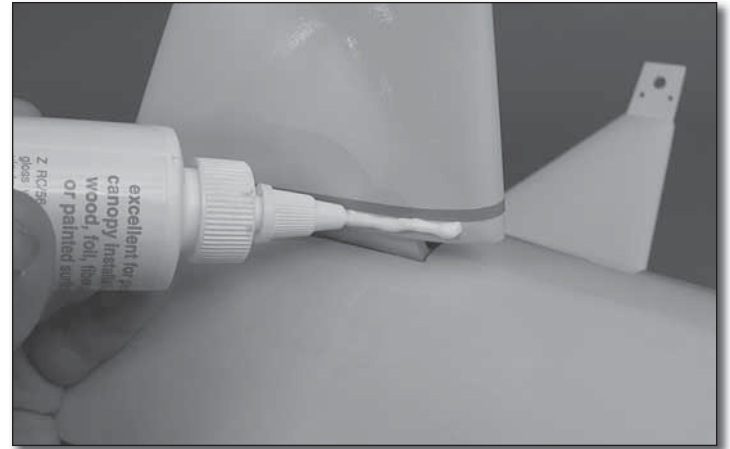

❑ 4. Remove one gear fairing at a time and apply a 3/16" [4.8mm] bead of R/C-56 canopy glue around the base of the gear leg using the masking tape as a guide. Fit the gear fairing back onto the gear leg. Repeat this for the other leg.

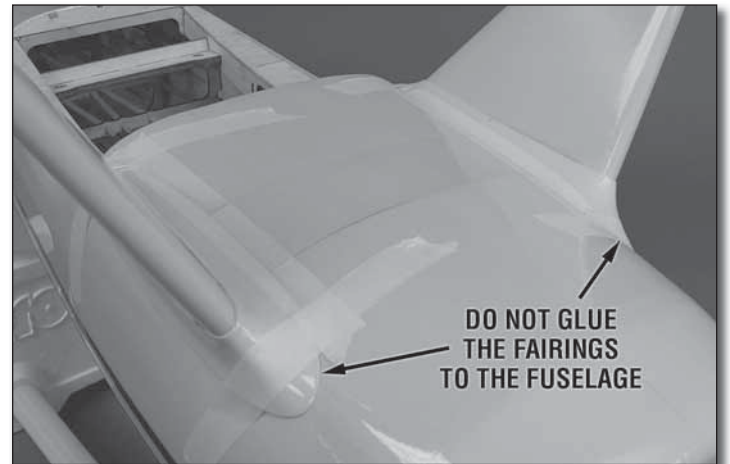

❑ 5. Tape the fairings up against the fuselage to hold them in place. Remove the tape after the glue dries. Gluing all the fairings to the landing gear will allow you to remove the landing gear easily if you have to in the future.

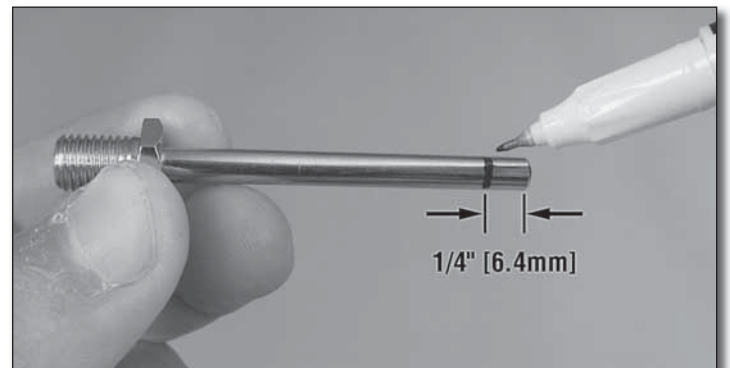

❑ 6. Cut 1/4" [6.4mm] off of the end of both main landing gear axles. A Dremel® rotary tool with a cutoff wheel attachment is handy for doing this. Otherwise, use a table vise and a hacksaw.

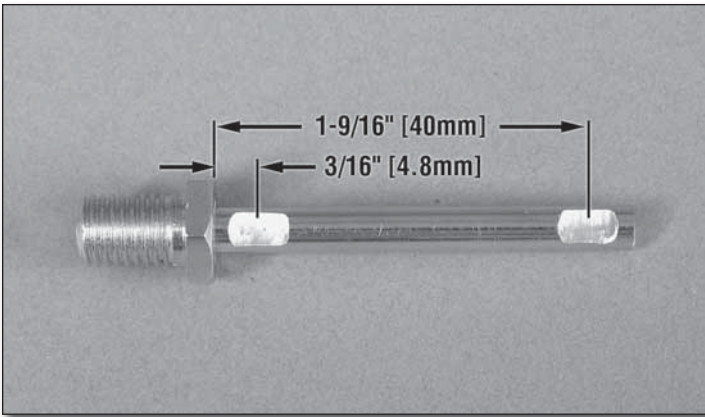

□ 7. File a 1/4" [6.4mm] wide flat spot at a distance 3/16" [4.8mm] from the base of the axle. File another one that is 1-9/16" [40mm] from the base of the axle.

□ 8. Install a 3-1/2" [89mm] wheel onto each axle using two 3/16" [4.8mm] wheel collars with two 6-32 x 1/4" [6.4mm] SHCS. Apply a drop of blue thread locking compound to the locking screw threads to prevent the screws from backing out.



□ 9. Using a 5/16-24 lock nut, install each axle assembly onto the main landing gear. Make sure that the heads of the set screws face directly down with respect to the model.

Cabane Strut Installation

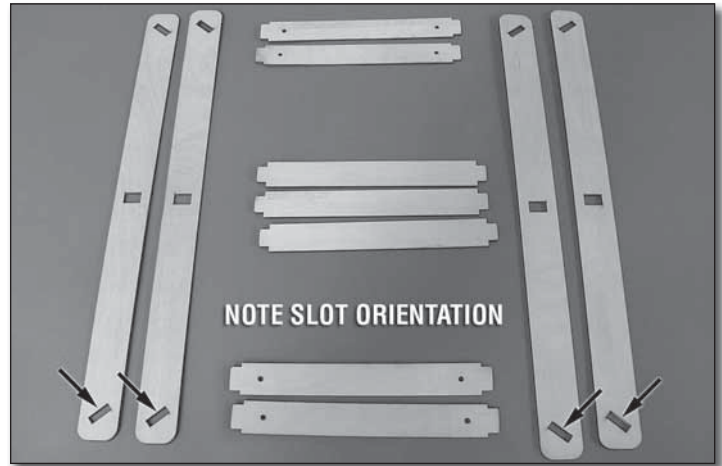

□ 1. Identify the eleven wood pieces that make up the carrying handle. Study the photo layout carefully. The center "handle" parts have no bolt holes and there are three of them. Glue these three together. Glue the other "doubled" parts together, being careful to line up the bolt holes and orient the slots properly. **Note:** You may use your choice of glue, but wood glue will give you the longest working time allowing you to fit everything together correctly.

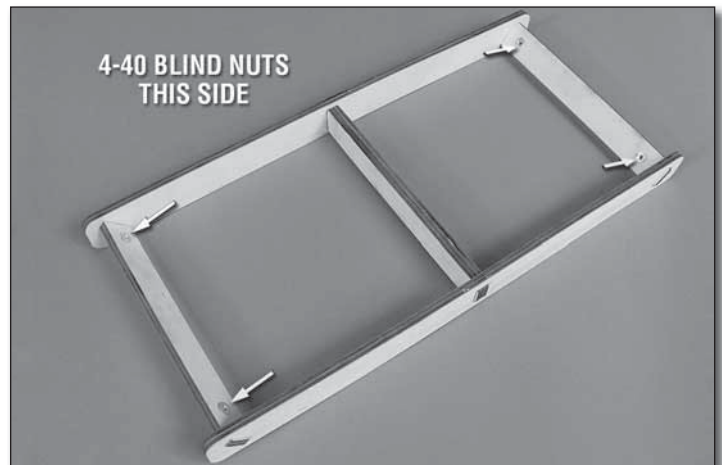

□ 2. Fit the parts together as shown. Join the center handle and the two cabane braces to one of the spanwise braces. Then, join the other spanwise brace to the assembly. Clamp the pieces together or wrap masking tape around the braces to hold them as the glue dries. Press four #4 blind nuts into the holes of the cabane braces from the inside as shown. Apply some 5-minute epoxy around the outside edges of the blind nuts to hold them permanently in place. Be careful not to get any epoxy into the screw threads.

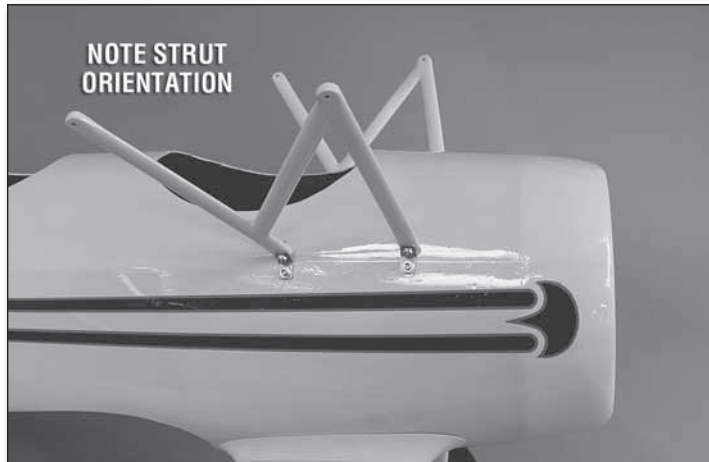
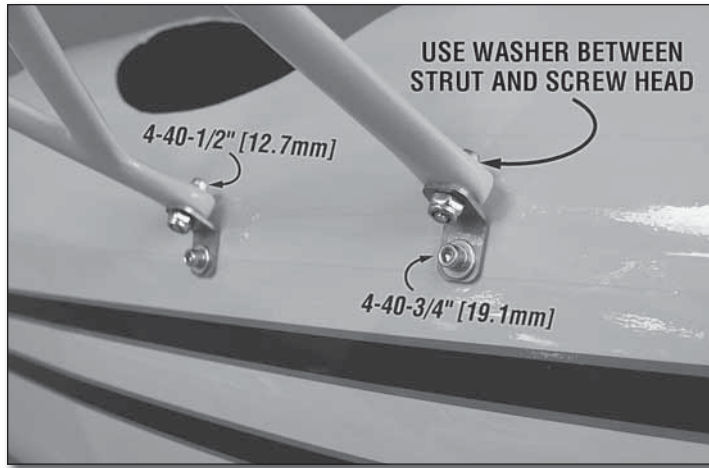

❑ 3. Identify the cabane bracket set for the fuselage. These four brackets are bent at 115° (the second flattest bend). Bolt these brackets to the fuselage using four 4-40 x 3/4" [19.1mm] SHCS, four #4 lock washers, and four #4 flat washers. Use a drop of thread locking compound on the screw threads. Note the orientation of the cabane struts. Use four 4-40 x 1/2" [12.7mm] SHCS, four #4 flat washers, and four #4 lock nuts to bolt the struts to the brackets. Bolt these on so that the heads of the screws face up with the washer under the screw head.

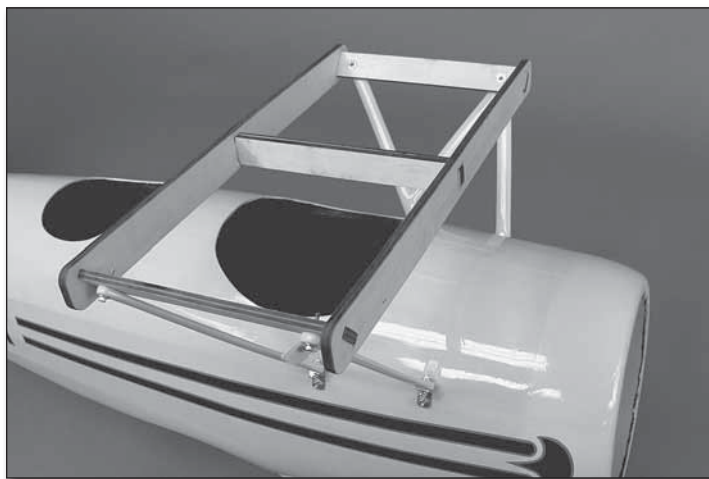

❑ 4. Using four 4-40 x 3/4" [19.1mm] SHCS and four #4 flat washers, bolt the finished carrying handle to the cabane struts. Leave the handle in place whenever the wings are off of the fuselage. This will prevent accidental damage to the cabanes and brackets.

Horizontal Stabilizer, Tailwheel and Rudder Installation

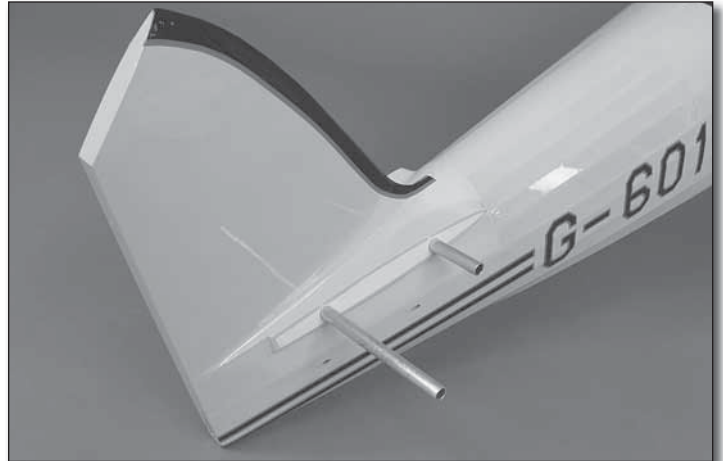

❑ 1. Once again, you'll need to have your epoxy supplies nearby and ready. Set the model down on its wheels. Fit the short 165mm x 10mm aluminum tube into the L.E. hole in the fuselage and the long 270mm x 10mm tube into the T.E. hole.

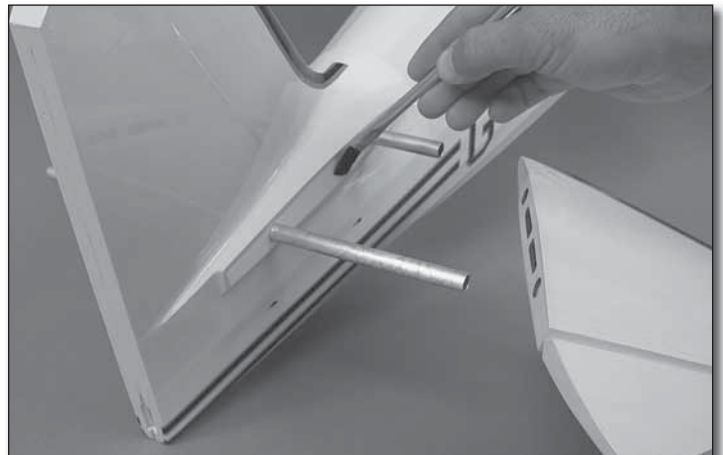

❑ 2. Mix up a batch of 30-minute epoxy. Coat the stabilizer tubes and the root rib of each stabilizer with epoxy. **Note:** There is no left or right stabilizer. Any stabilizer can be placed on any side.

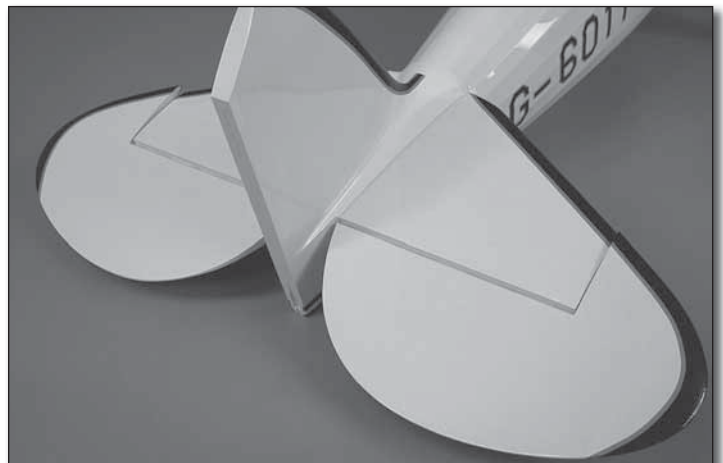

❑ 3. Fit the stabilizers to the fuselage. Hold the stabs tight up against the fuse with masking tape. Clean up any excess epoxy with denatured alcohol and paper towels.

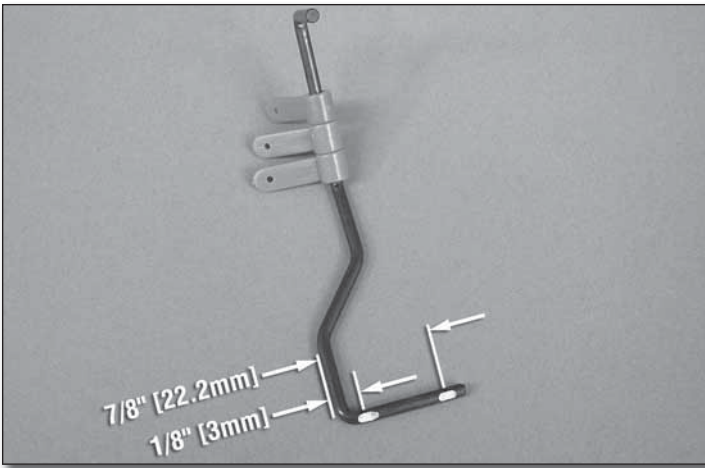

❑ 4. Remove the two 3mm wheel collars and the tailwheel from the tailwheel assembly. Grind two 1/8" [3.2mm] flat spots on the axle so that one is centered 1/8" [3.2mm] from the support arm and one is centered 7/8" [22.2mm] from the support arm.

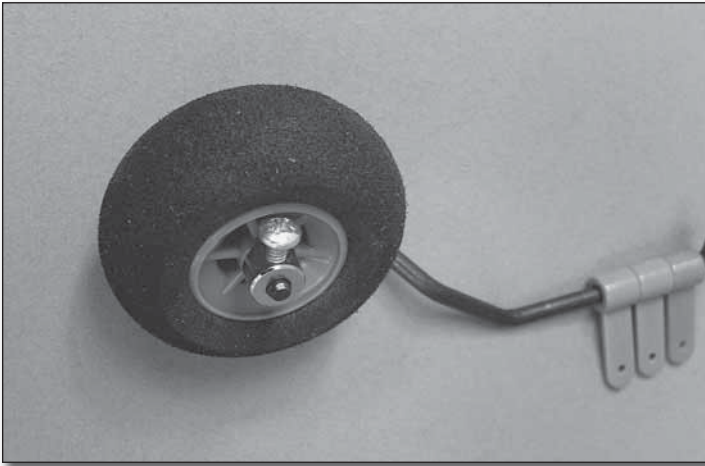

❑ 5. Reinstall the wheel and the wheel collars. Apply one drop of thread locking compound to the locking screw threads and tighten the locking screws against the flat spots you created on the axle.

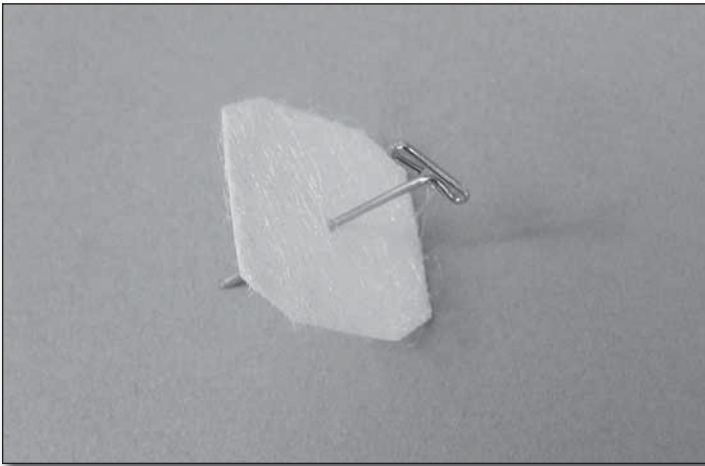

❑ 6. Prepare the three CA hinges for the rudder by inserting a T-pin through the center of the hinge.

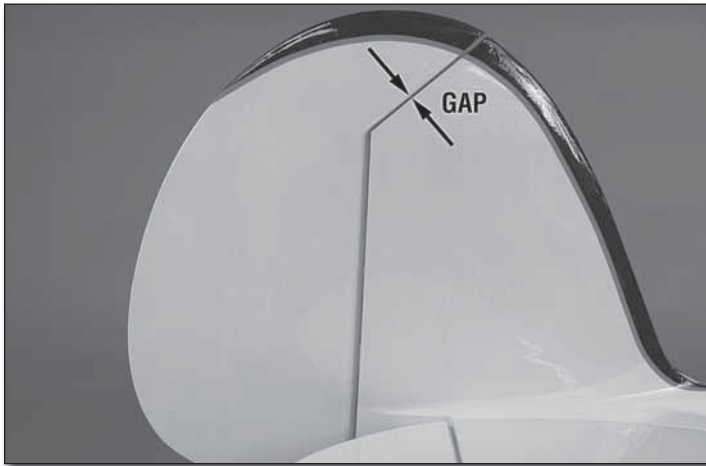
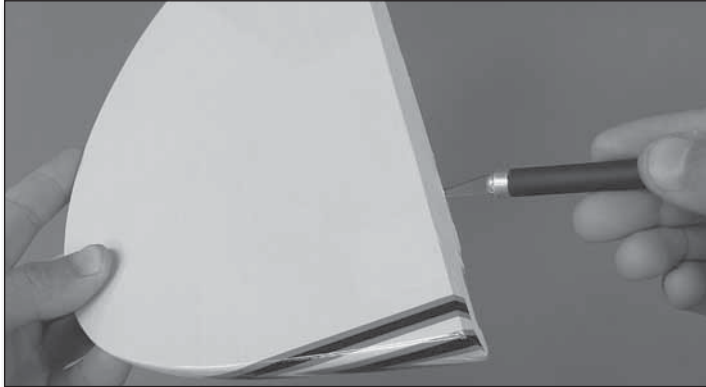
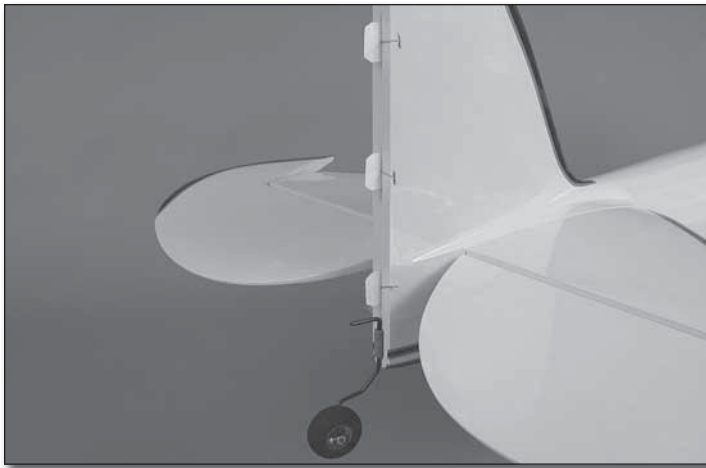

❑ 7. Test fit the hinges and the tail wheel into the pre-cut slots in the fuselage. Test fit the rudder onto the hinges and onto the tailwheel guide wire. The rudder hinge line should have only a small gap with the T-pins holding the hinges centered. Use the back side of your hobby knife to dig out the hinge slots if you can't fully insert a hinge. Slide the rudder up or down so there is just enough of a gap between the fin and the rudder counterbalance to allow full rudder travel. Remove the rudder from the fin.

Pushrod, Control Horn and Servo Installation

❑ 1. Turn the model over. Slide two 36" [914mm] pushrods into the left and right elevator pushrod guide tubes so that the unthreaded end goes to the servo tray inside of the fuse.

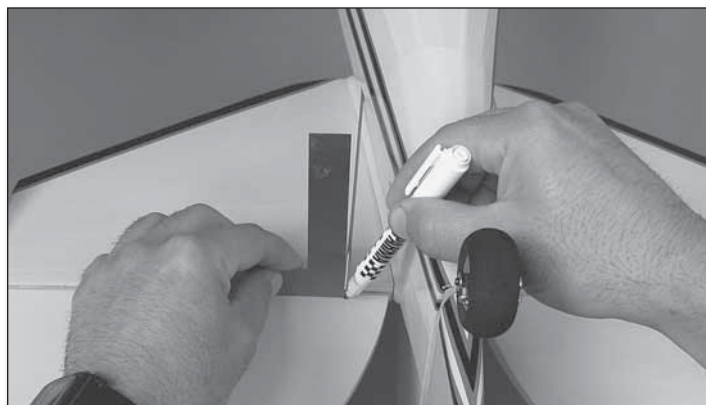

❑ 2. Using the pushrods as a guide, mark the elevators where you will install the control horns. Use a builder's square or triangle to help you project the line directly down from the pushrod or use the control horn to help you do this.

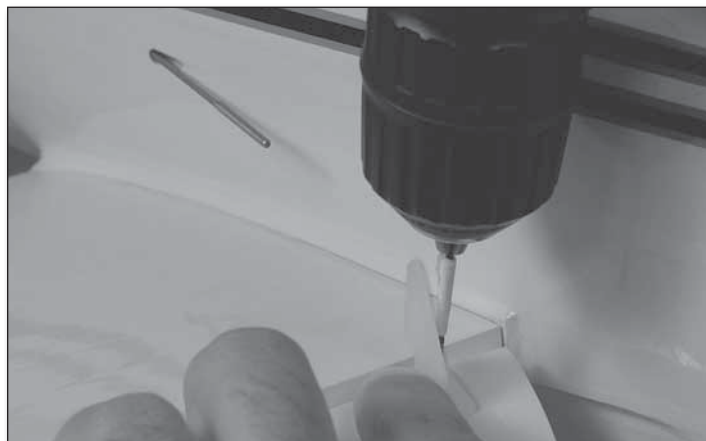

❑ 3. Remove the pushrods or slide them forward out of your way. Center a control horn over the line you drew on each elevator so that the pushrod holes in the horn are directly over the hinge line. Hold the horn in position and drill two 1/2" [12.7mm] deep holes using a 1/16" [1.6mm] drill. Be careful not to drill completely through the elevators.

❑ 4. Install the control horns using two #2 x 1/2" [12.7mm] sheet metal screws per horn. Harden the screw holes with thin CA.

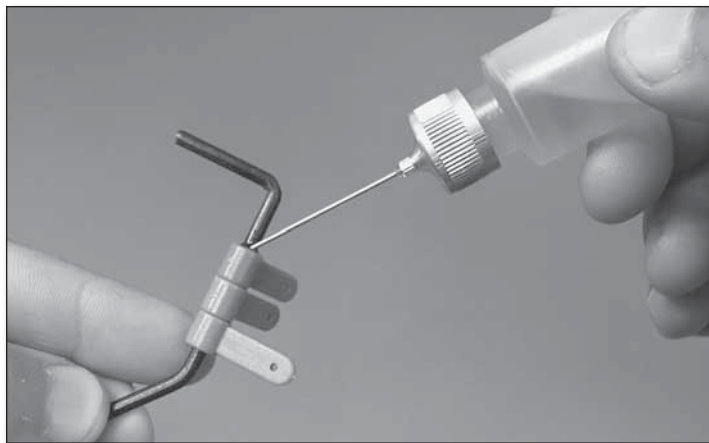
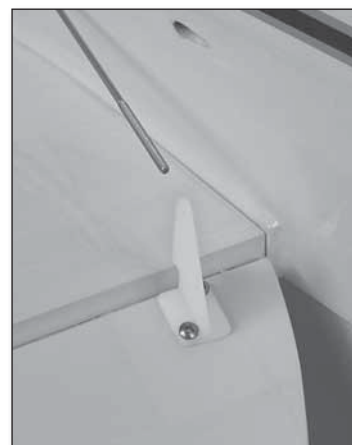

❑ 8. Remove the tailwheel assembly and add a few drops of lightweight machine oil to each hinge bushing. Clean the surface of the hinge straps with some alcohol.

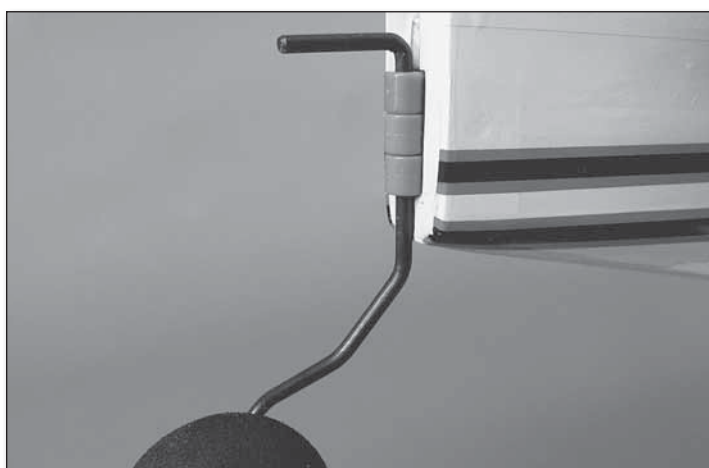

❑ 9. Apply 30-minute epoxy to the hinge straps and fit the tailwheel to the fuselage. Wipe up any excess epoxy to keep it from interfering with the operation of the tailwheel steering. Apply some epoxy to the tip of the tailwheel guide wire and into the corresponding hole in the rudder.



❑ 10. Fit the rudder. Remove the T-pins and deflect the rudder right and left several times as you push the rudder up against the hinge line. Hold the rudder up against the hinge line as you deflect it one direction. Wick about 5-8 drops of thin CA into each hinge. Deflect the rudder the opposite direction and wick CA into the other side of each hinge.



□ 5. Install a nylon clevis and a silicone retainer on each elevator pushrod. Be sure to screw the pushrod into the clevis far enough so that at least 1/8" [3.2mm] of the threaded end extends into the clevis barrel. If you removed the pushrods, slide them back into the pushrod guide tubes. Fit the clevises to the outer hole of the elevator horns. Slide the silicone retainer into position.



□ 6. Use the last 36" [914mm] pushrod to mark the position of the rudder control horn. Position a control horn over the mark you made and drill two 1/2" [12.7mm] deep holes using a 1/16" [1.6mm] drill bit. Install the control horn using two #2 x 1/2" [12.7mm] sheet metal screws.



□ 7. Install a nylon clevis and a silicone retainer on the rudder pushrod. Fit the clevis to the outer hole of the rudder horn and slide the silicone retainer into position.

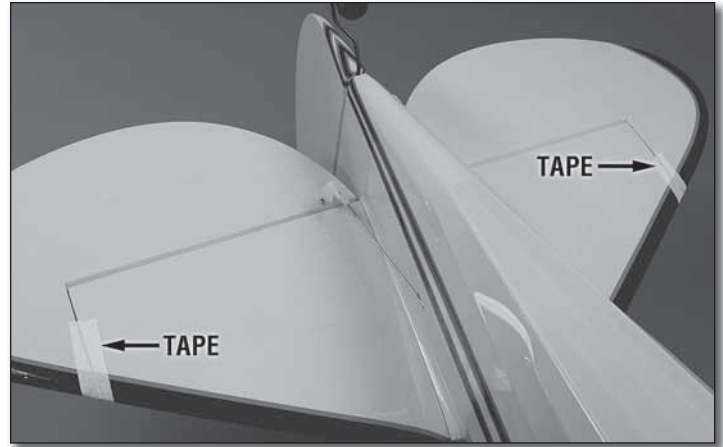

□ 8. Use a piece of masking tape to tape each elevator counterbalance to the stabilizer so that the elevators will remain centered for the next few steps.

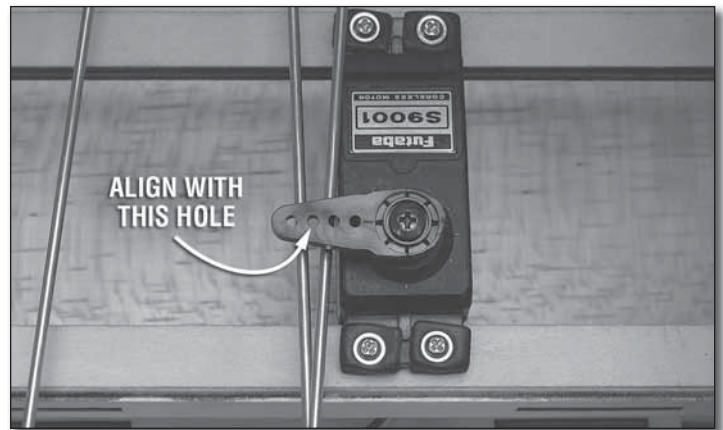

□ 9. Prepare one servo so that the servo arm is 90° to the servo case. Clip off the unused arms so that your servo looks like the one shown above. Align your servo so that the second outermost hole (or the hole that is 1/2" [12.7mm] from the center of the servo output shaft) is centered between the two elevator pushrods. Install the servo in that position using a 1/16" [1.6mm] drill and the screws that came with your servo.

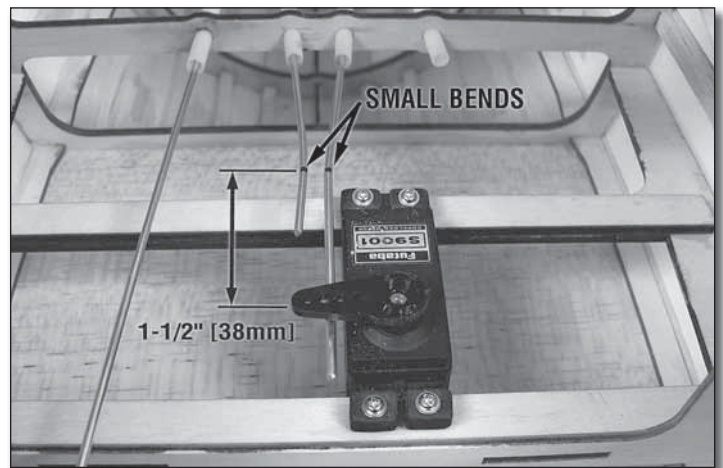

□ 10. Make an equal bend in each pushrod wire 1-1/2" [38mm] back from the holes in the servo arm so that each wire points straight forward. Cut the left elevator pushrod 3/4" [19.1mm] forward of the bend. Cut the right elevator pushrod 1/2" [12.7mm] forward of the servo arm holes.

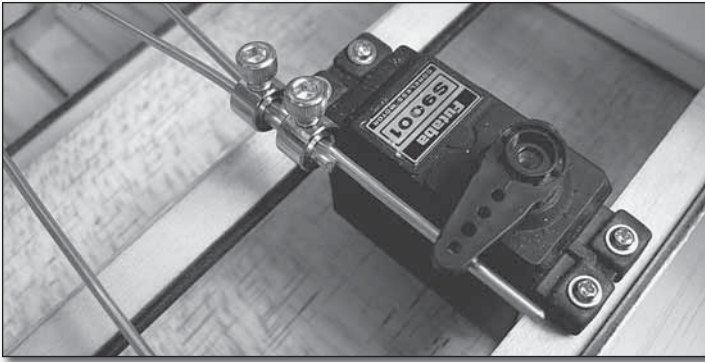

❑ 11. Fit two 3/16" [4.8mm] wheel collars onto the elevator pushrod wires. Use a drop of thread locking compound on the screw threads and fit two 6-32 x 1/4" SHCS. With both elevators centered, tighten the collar locking screws to hold the two wires together securely.

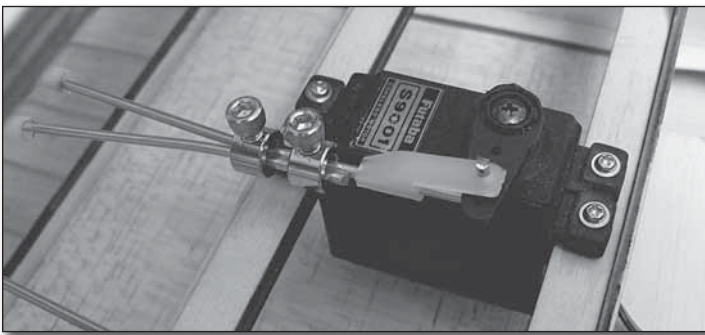

❑ 12. Mark the pushrod at the servo arm and make a 90° vertical bend. Drill the second outermost servo arm hole using a 5/64" [2mm] drill. Fit the pushrod to the servo arm. Secure the pushrod with a nylon Faslink. Cut off the excess pushrod wire. Install the servo arm screw.

❑ 13. If you need to make any minor adjustments to the elevators, make the adjustments at the individual elevator clevises rather than at the collars. Remember to secure the clevises with the silicone retainers when you are done making adjustments.

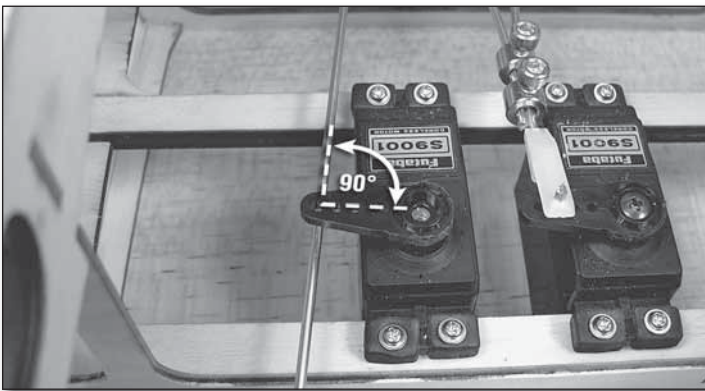

❑ 14. Use a 1/16" [1.6mm] drill bit to install the rudder servo so that the outermost hole in the servo arm is aligned with the rudder pushrod wire as shown. **Note:** The servo arm must be positioned on the output shaft so that there is a 90° bend between the arm centerline and the pushrod. Choose the servo arm that aligns best and clip off the remaining servo arms. Remember to harden the screw holes with thin CA.

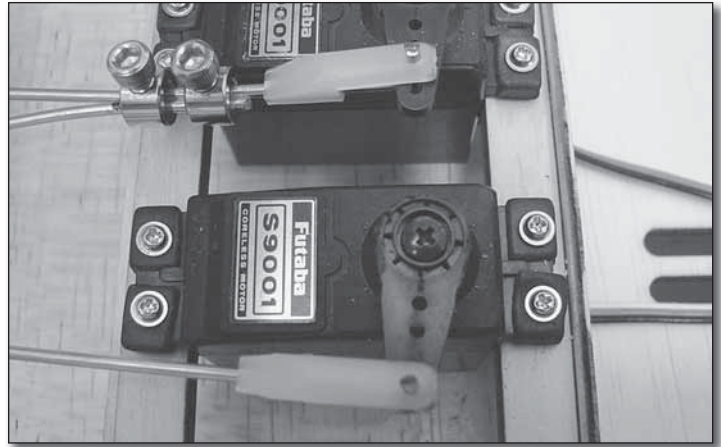

❑ 15. Mark the rudder pushrod at the servo arm hole and make a 90° bend. Drill a 5/64" [2mm] hole. Install the pushrod on the servo arm and secure it with a nylon Faslink. Cut off the excess pushrod wire. Install the servo arm screw.

❑ 16. Make any adjustments to the pushrod length to center the rudder and re-secure the clevis with the silicone retainer.

GLOW ENGINE INSTALLATION

This section will cover the installation of an O.S. FS-1.20S-E Surpass four-stroke glow engine. A two-stroke .91 sized engine can be installed with a Pitts-style muffler. If you are installing a different engine, please respect the firewall to prop washer dimension of 6-11/16" [170mm]. Plywood spacers are included that work with the two bolt patterns etched on the firewall. This engine is best mounted with the cylinder on the right side and the exhaust facing down.

Mount the Engine

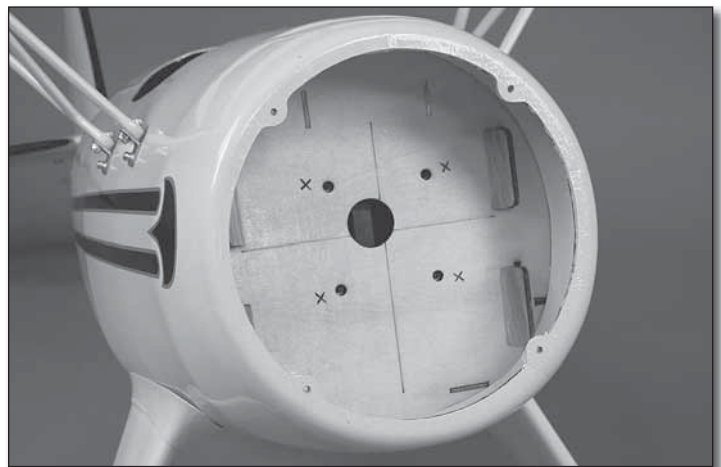

❑ 1. To install the O.S. FS-1.20S-E Surpass four-stroke glow engine (or any engine using the supplied nylon engine mount), drill the firewall at the four engraved "+" marks on the firewall using a 3/16" [4.8mm] drill. These marks line up with the two nylon engine mount halves that are supplied in this kit. If you plan on using a different engine mount, please use the vertical and horizontal centerline "crosshair" marks on the firewall to line up the template that came with your mount.

- ❑ 2. Install the four 8-32 blind nuts on the firewall from the back side. Use four 8-32 x 1" [25.4mm] SHCS with four #8 flat washers to help draw the blind nuts into the holes.

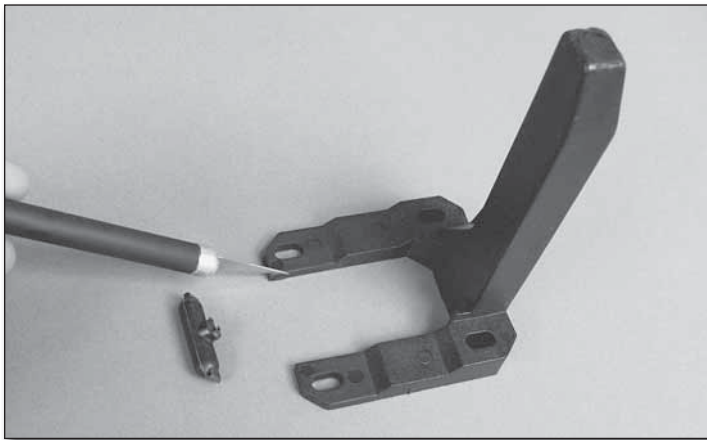

- ❑ 3. Break the tangs out of the two engine mount halves. File or trim away any portion that remains.

- ❑ 4. Identify the six glow engine spacers by matching the bolt holes on the spacers to the bolt holes on the back of the engine mount. For this installation, you will need three of these spacers.

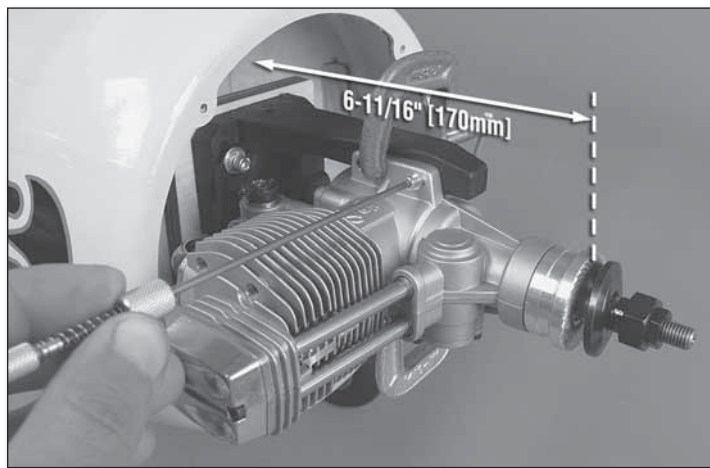

- ❑ 5. Fit the two engine mount halves together. Using three glow engine spacers behind the mount, loosely fit the mount to the firewall using four 8-32 x 1-1/2" [38mm] SHCS, four #8 lock washers, and four #8 flat washers. Adjust the width of the mount as you fit the engine. Slide the engine forward or back on the mount until the drive washer is 6-11/16" [170mm] from the face of the firewall. Hold the engine in place with two 1" [25.4mm] adjustable clamps. With the engine in position, use a Great Planes Dead Center™ Engine Mount Hole Locator (GPMR8130) to drill four pilot holes or mark the position of the holes onto the engine mount legs with a felt-tipped silver marker.

- ❑ 6. Remove the engine from the mount. Remove the mounts from the model. Drill and tap the holes for 8-32 bolts using a tap and drill set (GPMR8103).

- ❑ 7. Mix up some 30-minute epoxy and thin it down with a little denatured alcohol. Glue the ply spacers together and coat them with epoxy to fuelproof them.

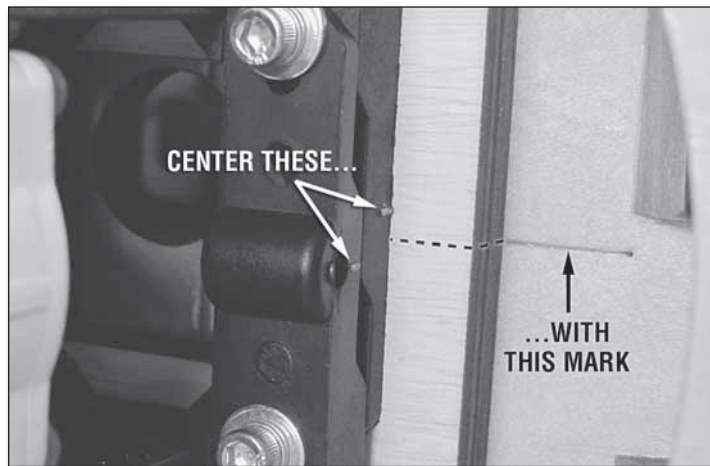

- ❑ 8. Install the engine mount with the ply spacers using four 8-32 x 1-1/2" [38mm] SHCS, four #8 lock washers, and four #8 flat washers. For added security, use a drop of thread locking compound on the screw threads. Then, install the engine to the mount using four 8-32 x 1" [25.4mm] SHCS, four #8 lock washers, and four #8 flat washers. Center the engine mount marks with the cross-hairs on the firewall. Tighten all screws.

Hook Up the Throttle

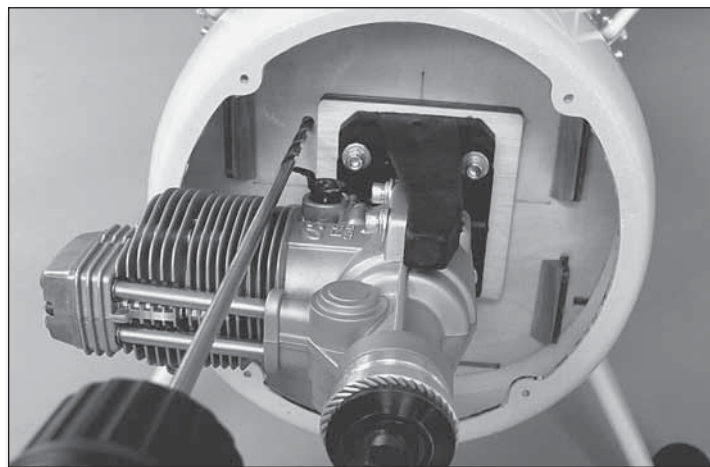

- ❑ 1. Using a long drill bit, drill a 3/16" [4.8mm] hole through the firewall in line with the engine's throttle arm. If you don't have a long drill bit, mark the position of the throttle arm and remove the engine before you drill the hole.

- ❑ 2. Dry fit the 24" [610mm] gray outer pushrod tube in the hole you just drilled. Slide the pushrod tube through the access holes in the formers and back to the servo tray.

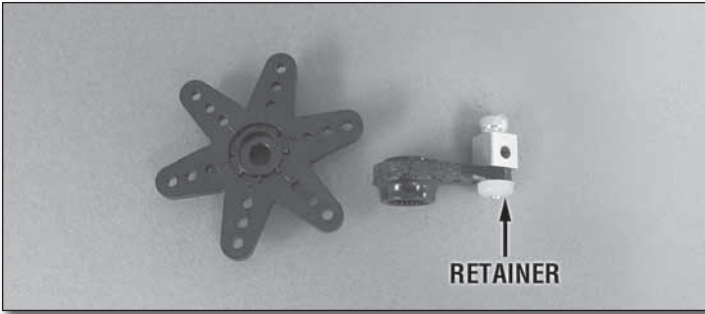

❑ 3. Fit a screw-lock pushrod connector to the outermost hole on short servo arm. Choose the arm that is 90° to the servo case at 1/2 throttle. Clip off the unused servo arms. Use a nylon retainer to secure the pushrod connector to the servo arm. Place a drop of thread locking compound on the screw threads and fit a 4-40 x 1/8" [3.2mm] SHCS. Fit the servo arm onto the servo. Install the throttle servo in the servo tray so that the end of the servo arm is in line with the pushrod tube.



❑ 6. Thread a nylon clevis onto a 36" [914mm] pushrod and fit a silicone retainer. Insert the pushrod into the pushrod guide tube. Slide the pushrod into the screw lock pushrod connector. Connect the clevis to the throttle arm. Secure the clevis with a silicone retainer. Do not tighten the screw lock pushrod connector yet.

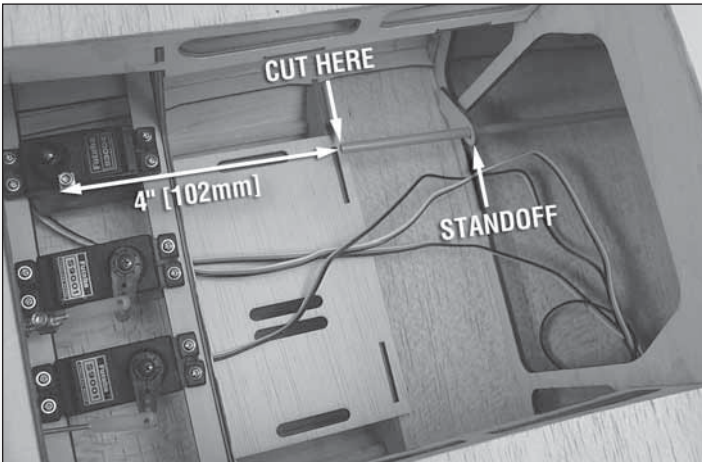

❑ 4. Position the pushrod tube about 4" [102mm] from the servo. Cut the pushrod tube 3/8" [9.5mm] forward of the firewall. Fit the wooden pushrod tube standoff inside the fuselage at the former that lines up with the leading edge of the lower wing. Mark the position of the standoff with a felt tipped pen. Remove the pushrod tube and sand the outside of the tube at the place that you marked and at the firewall end of the tube.

❑ 5. Glue the pushrod tube in place at the firewall using epoxy.

❑ 7. Turn on your radio and check to see that the servo moves in the proper direction. With the throttle servo and the throttle set to full, tighten the screw on the screw lock pushrod connector. Cut off any excess pushrod and test the operation of the throttle. Glue the wooden standoff to the former as shown so that the pushrod tube is supported.

❑ 8. Install the servo arm retaining screw. Use this opportunity to set up a throttle cutoff and a flight timer on your transmitter.

Install the Fuel Tank

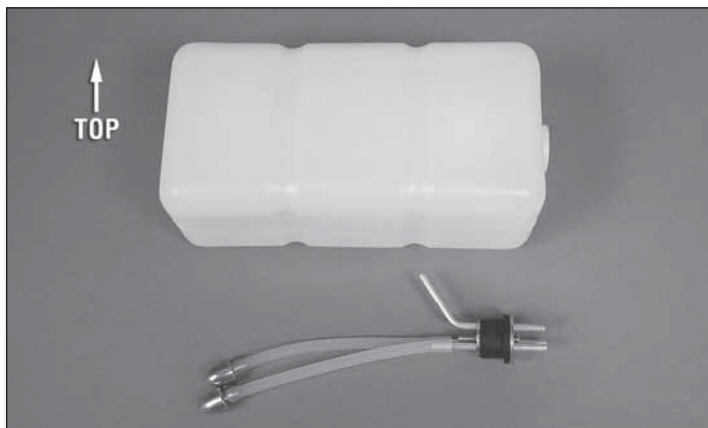

❑ 1. Cut two pieces of glow fuel line and attach to clunks. Make sure the fuel line isn't so long that gets caught on the back of the tank. Build up the fuel tank as shown with the vent line pointing to the top of the tank. You may want to use a felt tip pen to mark which direction the vent line is pointed so that you know where the top of the tank is when you're installing the tank.

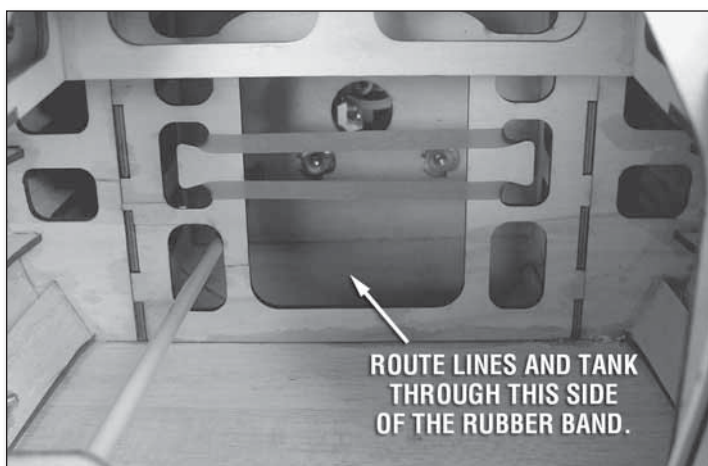

❑ 2. Fit a rubber band to the former behind the firewall as shown. When you install the fuel tank, route the lines and then the tank above the rubber band (toward the top of the model) as you stretch the rubber band under the bottom side of the tank.

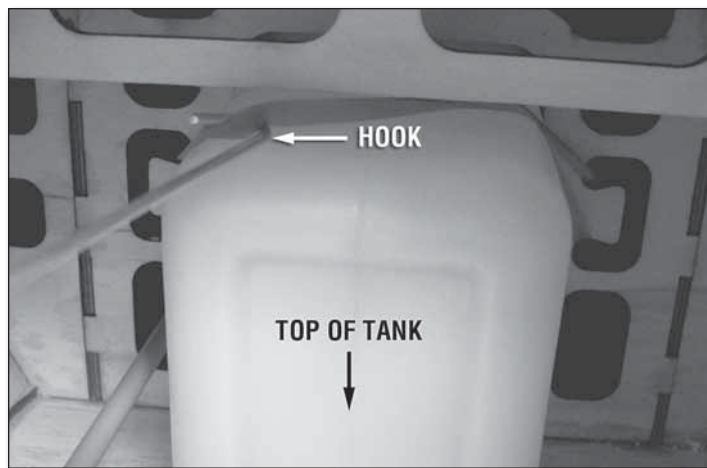

❑ 3. Fit fuel lines to the tank and route the lines through the hole in the firewall as you fit the tank. Be careful to make sure that the vent line is pointed toward the top of the model. Make a hook out of a piece of scrap pushrod to pull the rubber band under the fuel tank.



❑ 4. Slide the tank all the way forward and pull the rubber band around the back side of the tank to hold it in place.

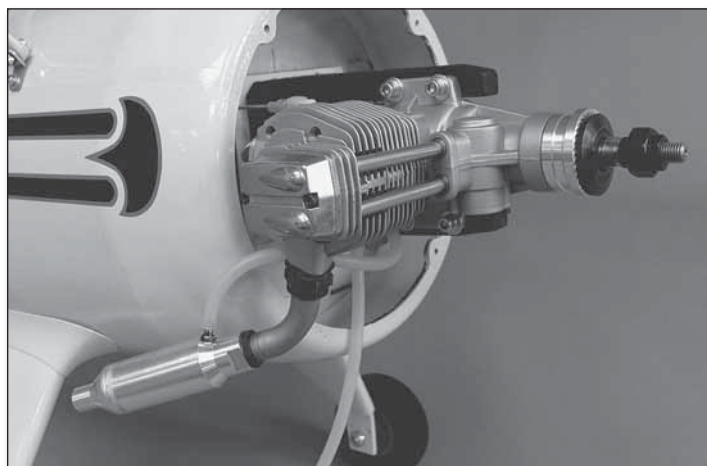

❑ 5. Connect the fuel line to the engine. Connect an aluminum fuel line plug to the fill/drain line. Temporarily fit the muffer and connect the muffer pressure line. Trim the excess line as needed, but leave extra length in the fill/drain line.

GASOLINE ENGINE INSTALLATION

This section will cover the installation of a DL Engines DLE-30cc gasoline engine. Other similarly sized gas engines can be used, but be careful to space the ignition equipment as far away as possible from the radio equipment. If you are installing a different engine, please respect the firewall to prop washer dimension of 6-11/16" [170mm]. Plywood spacers are included for the DLE-30 engine. This engine is best mounted with the cylinder inverted.

Note on the side carb DLE-30: This is supplied with 30mm spacers and M5 metric bolts. Because of the required standoffs, you will need to purchase longer hardware. You may use M5 bolts or 10-32 bolts and matching blind nuts. You can find these at some larger hardware stores or fastener suppliers.

Note on the rear carb DLE-30: This is supplied with 60mm spacers that are threaded on both ends for 5mm metric bolts. Four M5 metric bolts are supplied with the engine. You will need to purchase four additional M5 metric bolts, washers, and lock washers to install the engine. Do not attempt to use 10-32 hardware. 10-32 bolts may seem to thread into the aluminum standoffs, but the thread fit is very loose. Tightening #10 bolts into the standoffs will cause the thread in the aluminum to strip and may cause your engine to separate from the firewall.

Mount the Engine

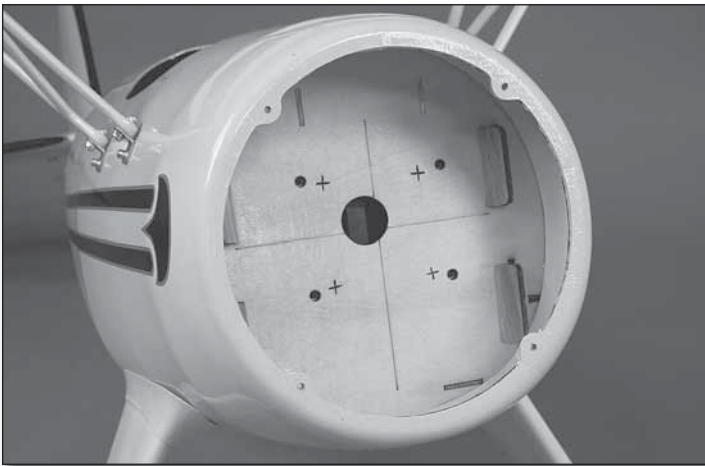

❑ 1. To install the DLE-30 gas engine, drill at the four engraved "X" marks on the firewall first using a 1/8" [3.2mm] drill and then stepping up to a 1/4" [6.4mm] drill if you are using the side carb engine, or a 3/16" [4.8mm] drill if you are using the rear carb engine. If you plan on using a different engine, please use the vertical and horizontal centerline "crosshair" marks on the firewall to line up the template that came with your engine.

❑ 2. If you are using the side carb DLE-30, install four 10-32 blind nuts on the firewall from the back side. Use four 10-32 x 1" [25.4mm] bolts with four #10 flat washers to help draw the blind nuts into the holes.

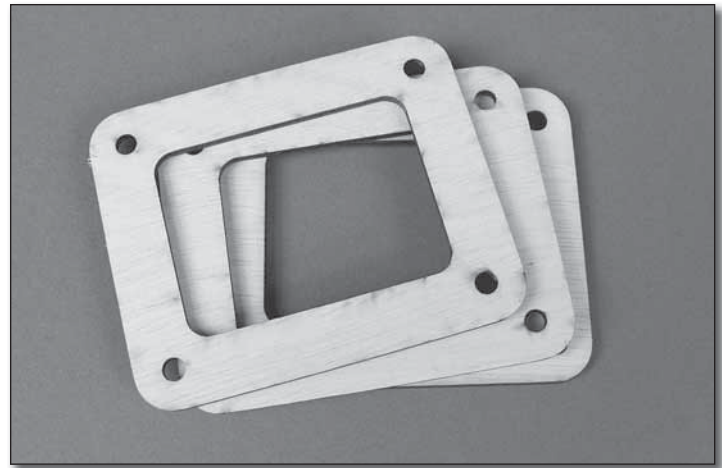

❑ 3. Identify the DLE-30 engine spacers by matching the bolt holes on the spacers to the bolt holes on the back of the engine. For the DLE-30 side carb installation, you will need to use thirteen of these 3mm ply spacers. For the DLE-30 rear carb, you will need to use three ply spacers. This will set the drive washer of the engine at 6-11/16" [170mm] from the firewall.

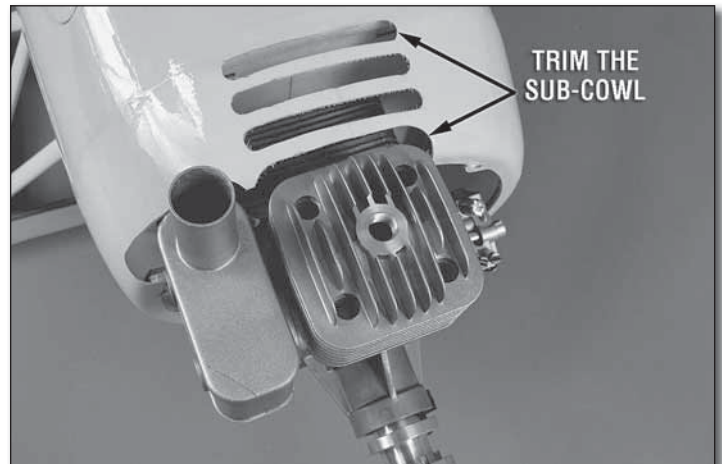

❑ 4. Test fit the engine with the spacers and standoffs using four 10-32 x 4" [102mm] bolts and four #10 lock washers (not supplied). If you are using the rear carb engine, use four M5 x 25mm bolts, four 5mm lock washers, and four 5mm flat washers. Mark the fiberglass sub-cowl areas that you will need to trim to clear the muffler and the cylinder head using a felt tip pen. Remove the engine and trim the sub-cowl. Trim additional cooling air vents in the sub-cowl to allow more airflow across the cylinder. **Note:** Because of the position of the muffler, you will need to trim away one blind nut from the sub-cowl.

❑ 5. Mix up some 30-minute epoxy and thin it down with a little denatured alcohol. Glue the ply spacers together and coat them with the epoxy to fuelproof them.

❑ 6. Mount the engine to the firewall using a drop of thread locking compound on the screw threads. **Note:** Because of the added vibration of a gas engine, you may want to go back and tighten these after a few flights. Check them periodically.

Hook Up the Throttle

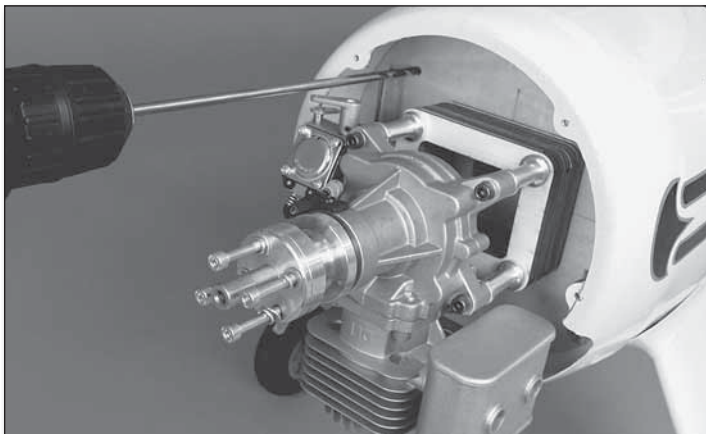

❑ 1. Using a long drill bit, drill a 3/16" [4.8mm] hole through the firewall in line with the engine's throttle arm. Offset this about 1/4" [6.4mm] up to allow for the ball link that you will need to attach to the throttle arm.



❑ 2. Dry fit the 24" [610mm] gray outer pushrod tube in the hole you just drilled. Slide the pushrod tube through the access holes in the formers and back to the servo tray.



❑ 3. Prepare the throttle servo by choosing the servo arm that is 90° to the servo case at 1/2 throttle. Clip off the unused servo arms. Drill the outermost hole on the arm using a 5/64" [2mm] drill bit. Then, fit the servo arm onto the servo. Install the throttle servo in the servo tray so that the end of the servo arm is in line with the pushrod tube. Harden the screw holes with thin CA.



❑ 4. Position the inside end of the pushrod tube about 4" [102mm] from the servo. Cut the pushrod tube 3/8" [9.5mm] forward of the firewall. Fit the wooden pushrod tube standoff inside the fuselage at the former that lines up with the leading edge of the lower wing. Remove the pushrod tube and sand the outside of the tube at the place that you marked and at the firewall end of the tube.

❑ 5. Glue the pushrod tube in place at the firewall using epoxy.

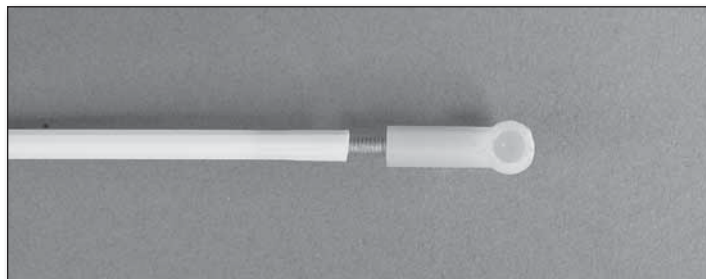

❑ 6. Thread a ball link onto a 1" [25.4mm] threaded rod so that at least 1/4" [6.4mm] of thread is engaged in the ball link. Thread the other side of the rod into the white inner pushrod tube so that 1/4" [6.4mm] of thread engages in the pushrod tube.

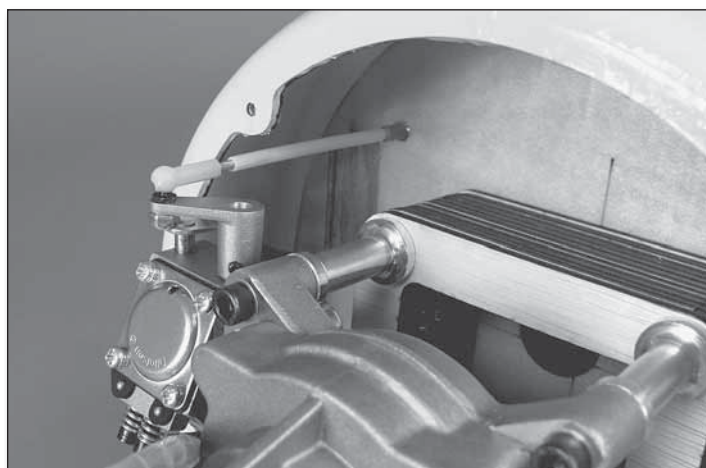

❑ 7. Drill and tap the throttle arm on the engine using a 2-56 drill and tap set. Thread a 2-56 ball link onto the throttle arm using thread locking compound on the screw threads. Install a 2-56 lock nut on the back side and tighten the ball link and lock nut onto the throttle arm.

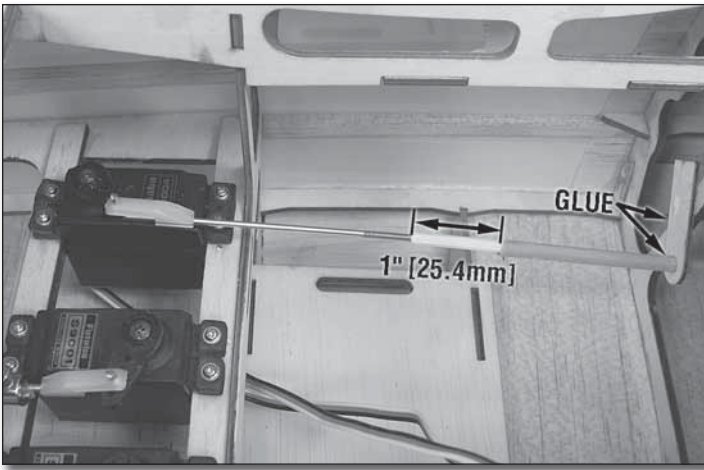

❑ 8. Dry fit the wooden pushrod tube standoff to the gray pushrod tube. With the throttle on the engine closed, set the servo to the idle cutoff position. Cut the inner pushrod tube about 1" [25.4mm] from the end of the gray pushrod tube. Thread a 6" [152mm] pushrod into the end of the inner pushrod tube so that at least 1/2" [12.7mm] of thread engages. Mark the pushrod at the servo arm and bend it 90° up. Clip off the excess pushrod and fit the pushrod to the servo arm. Then, use a nylon Faslink to secure it. Glue the wooden standoff to the former and the pushrod tube to the standoff using epoxy. Test the operation and make any mechanical adjustments now. Install the servo arm locking screw.

❑ 9. You may set up a servo operated choke at this point. If you are doing this, you will need to purchase nylon pushrod linkage similar to the pushrod supplied for the throttle. We set up a manual choke using scrap pushrod and a rubber servo grommet to guide the pushrod through the cowl.

Install the Fuel Tank

In order to use gasoline with the fuel tank supplied, you will need to purchase a fuel tank conversion kit and gas fuel line.

❑ 1. Solder a set of fuel line barbs onto the fuel lines using silver solder.

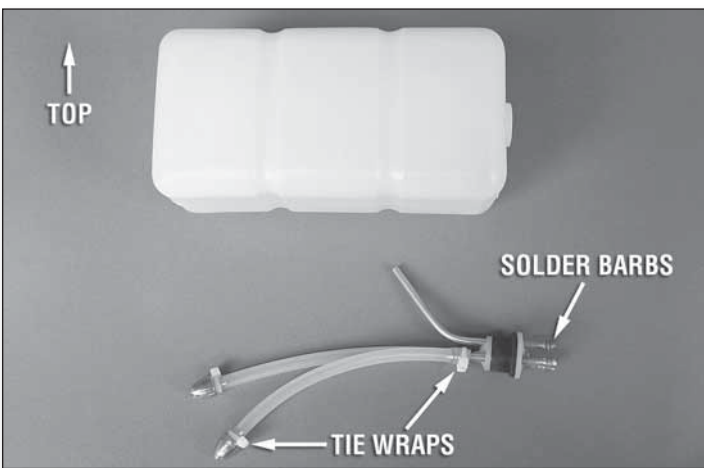

❑ 2. Discard the silicone fuel line and stopper supplied with the fuel tank. Cut two pieces of gasoline compatible fuel line.

Secure the lines and the clunks with four small 4" [102mm] tie wraps. Build up the fuel tank as shown with the vent line pointing to the top of the tank. You may want to use a felt tip pen to mark which direction the vent line is pointed so that you know where the top of the tank is when you're installing the tank.

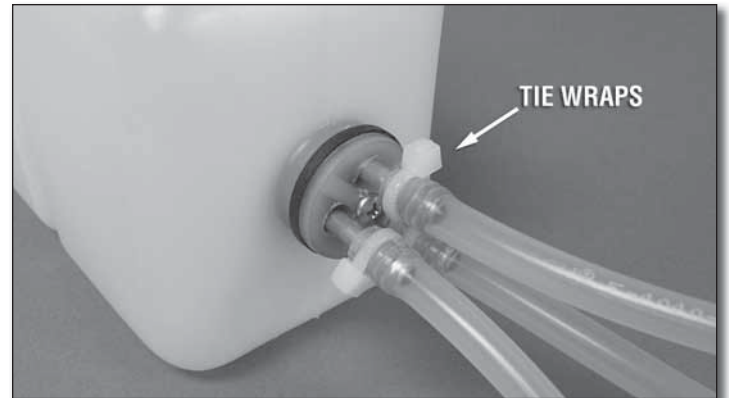

❑ 3. Fit fuel lines to the outside of the fuel tank. Secure each line with a small 4" [102mm] tie wrap.

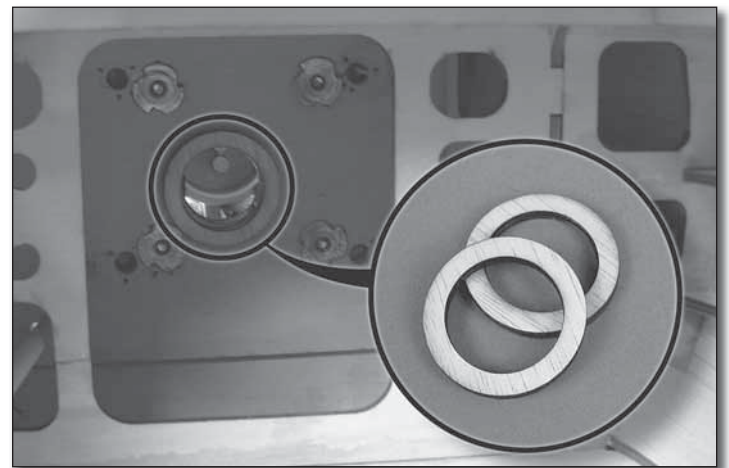

❑ 4. Test fit the fuel tank to make sure that the engine bolts will not touch the front of the tank. If they do, glue plywood fuel tank spacers to the back of the firewall so they line up with the hole, using as many spacers as are needed to clear the bolts.

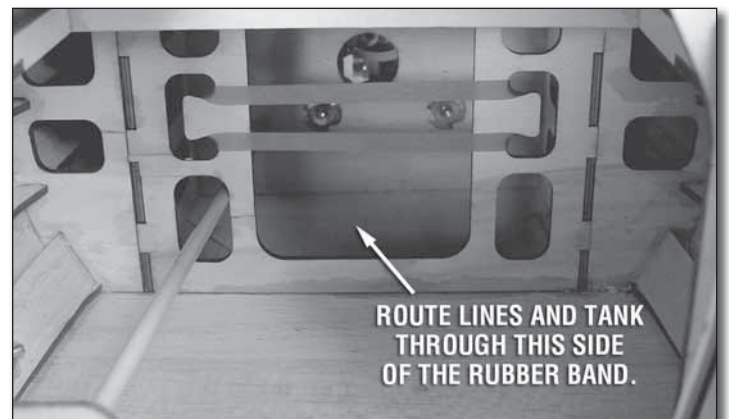

❑ 5. Fit a rubber band to the former behind the firewall as shown. When you install the fuel tank, route the lines and then the tank above the rubber band (toward the top of the model) as you stretch the rubber band under the bottom side of the tank.

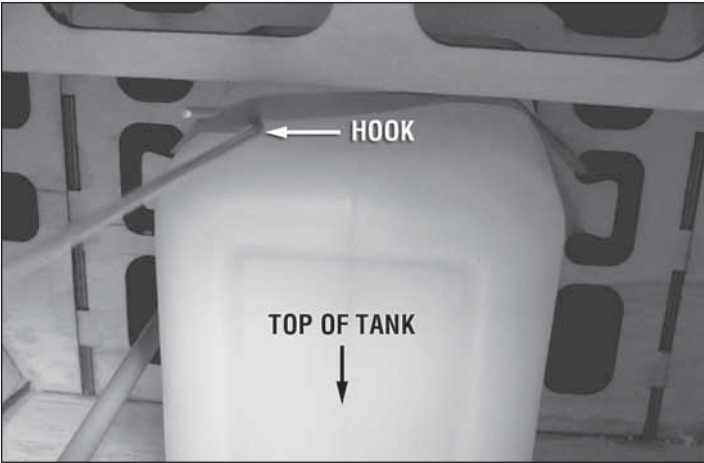

❑ 6. Fit fuel lines to the tank and route the lines through the hole in the firewall as you fit the tank. Be careful to make sure that the vent line is pointed toward the top of the model. Make a hook out of a piece of scrap pushrod to pull the rubber band under the fuel tank.



❑ 7. Slide the tank all the way forward and pull the rubber band around the back side of the tank to hold it in place.

❑ 8. Connect the fuel line to the engine. Connect the aluminum fuel line plug to the fill/drain line. Trim off any excess line for the carburetor, but leave a little extra length in the fill/drain line and the vent line.

Install the Ignition Unit

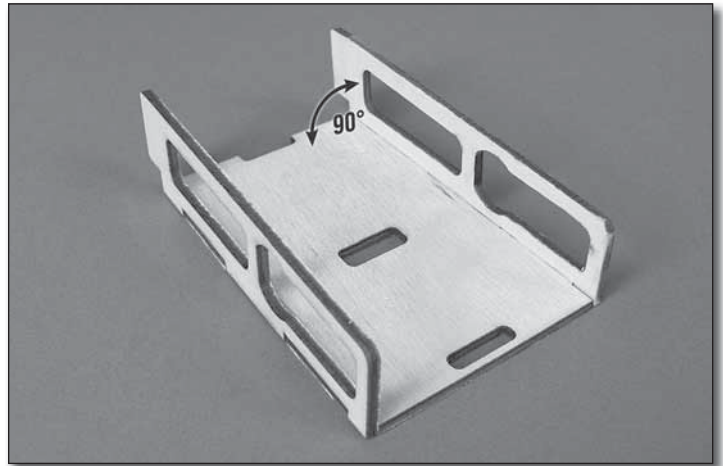

❑ 1. Build the ignition unit and battery tray using a small builder's square or triangle to set the upright pieces 90° to the base. Use 5-minute epoxy to assemble the tray. Fuelproof the tray with a mixture of epoxy and denatured alcohol.

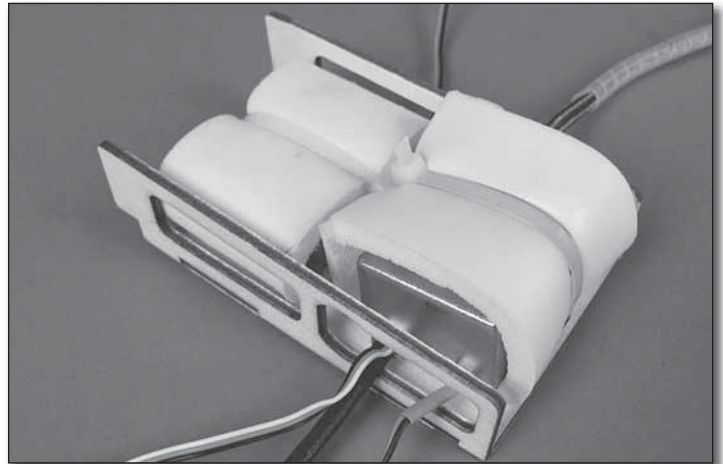

❑ 2. Wrap the ignition unit and the battery in 1/4" [6.4mm] latex foam rubber. Place the battery directly behind the ignition unit. Secure both of these to the tray using two large 8" [203mm] tie wraps.



❑ 3. Knock out the wood from the two vertical slots at the top of the firewall. Sand the firewall on the outboard side of each slot. This is where you will glue the triangle stock for the tray.

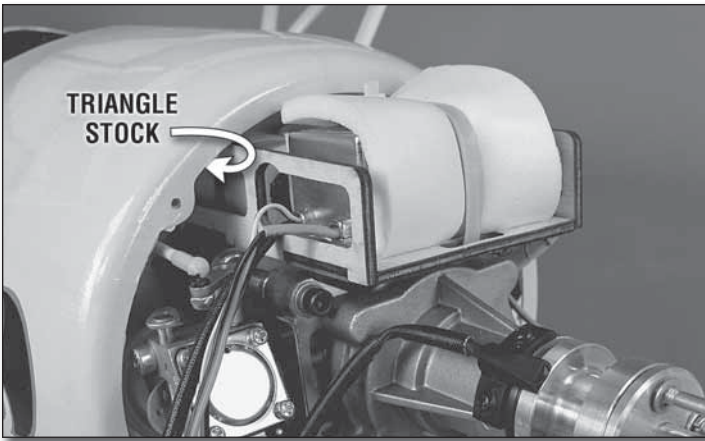

❑ 4. Mix up a small batch of 5-minute epoxy and coat the ignition tray tabs and the corresponding slots at the top of the firewall. Install the tray. Use the two triangle stock pieces to help secure the tray. Glue the triangle stock to the outside of the tray between the tray and the firewall.

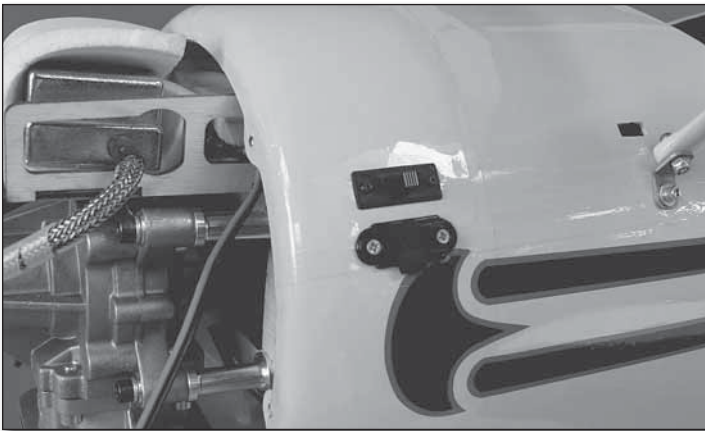

❑ 5. Use the template at the back of this manual to cut holes in the fiberglass sub-cowl near the upper left corner (2 o'clock position) for the ignition switch and the battery charge jack. Position the template so that the rear cut line of the template lies over the aft edge of the sub-cowl. This will allow enough room for the switch on the back side. **Note:** Positioning the switch here is important so that it is away from heat and gasoline. Install the ignition switch and the charge jack. Connect the ignition battery to the switch and the switch to the ignition unit. Secure both of these connections with heat shrink tubing.



❑ 6. Cut an access hole in the sub-cowl and pass the spark plug lead through it. Connect the lead to the spark plug.

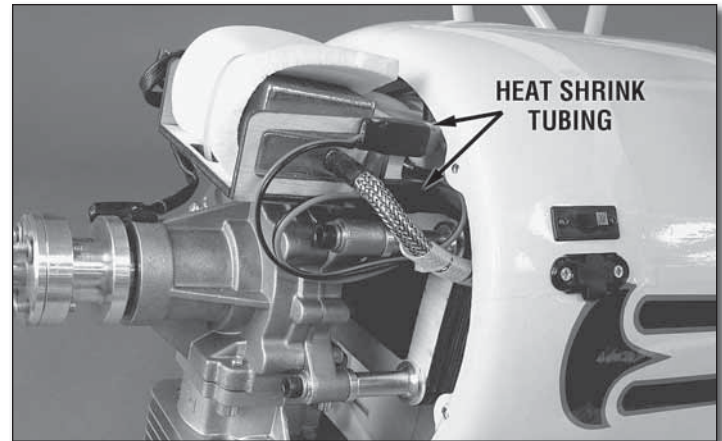

❑ 7. Connect the remaining wires for the ignition unit. Secure each connection with heat shrink tubing. Bundle the wires together and secure them using small tie wraps.

FINAL ASSEMBLY

Radio Installation

To complete the radio installation, you will need three Y-harnesses for the top and bottom wing aileron servos. If you have a computer radio that has mixing functions, you can use only two Y-harnesses and group the upper wing servos on one channel and the lower wing servos on another.

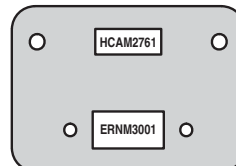

Hobbico HD & Ernst

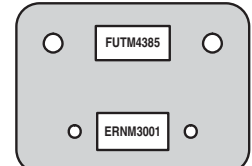

Futaba HD & Ernst

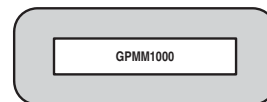

Great Planes

❑ 1. Three plywood switch mounting plates are included. Choose the one that fits your switch. We will use the Great Planes switch mount (GPMM1000).



❑ 2. Use the plywood switch mounting plate as a template to cut holes for the radio switch and charge lead. Mount the switch

and charge lead in the front or rear cockpit floor. Be careful to choose a place where the switch will not interfere with the servos or pushrods underneath. **Note:** If you will be installing a pilot figure, temporarily fit the pilot figure to the cockpit so that you know where to position the switch and charge jack.

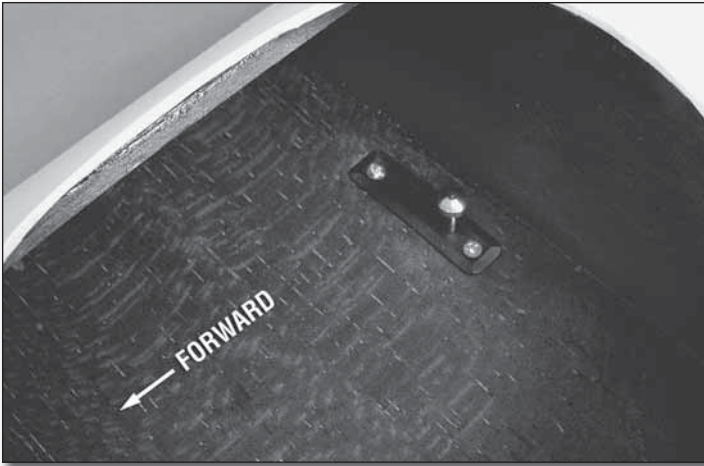

❑ 3. Glue the switch mounting plate to the back side of the cockpit floor and install the switch and charge jack.

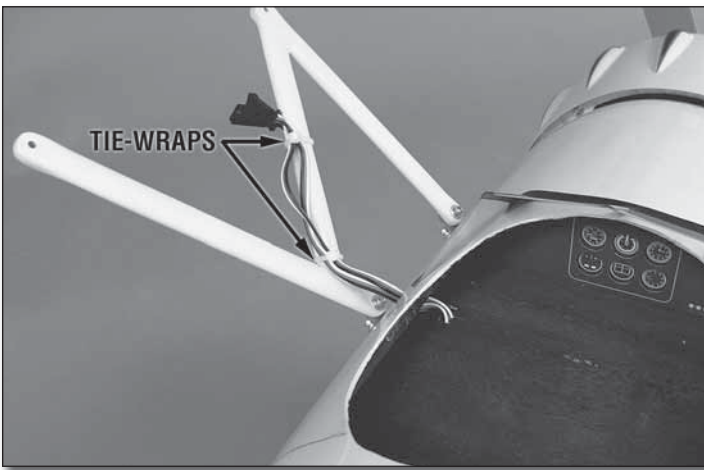

❑ 4. Install a 21" [533mm] Y-harness (HCAM2500) for the top wing ailerons. Fit the male plug through the rectangular access hole in the fuselage by the left cabane strut. Use two small 4" [102mm] tie wraps to secure the harness to the strut.

Cut the hook and loop material to the correct length and join the pieces together to make a strap.

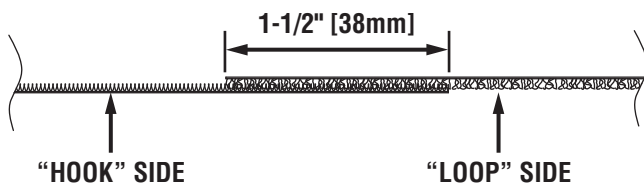

❑ 5. Cut a 5" [127mm] piece of hook and loop material. Separate the hook side from the loop side and rejoin them so that 1-1/2" [38mm] overlaps in the middle to make a battery strap. Make a second strap for your receiver using a 4" [102mm] piece of hook and loop material.



❑ 6. Plug another Y-harness into the aileron channel of your receiver for the lower wing ailerons. Wrap the receiver battery pack and your receiver in latex foam rubber. Plug the elevator, rudder, top wing aileron Y-harness, and throttle into the receiver. Use the straps you made to attach the battery pack and the receiver to the battery tray. If you are using a 2.4GHz radio, route the antennas in a clear location. You can use a short piece of glow fuel tubing or some remaining throttle pushrod tube to make short tubes to support and hold the antennas in position.

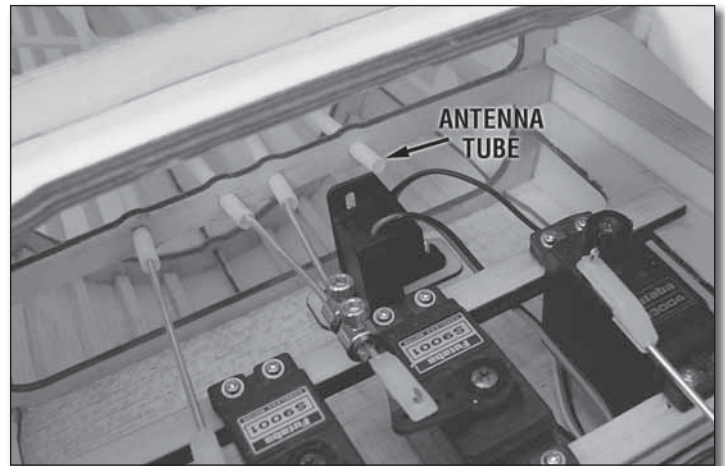

❑ 7. If you are using a 72MHz radio, route the antenna through the antenna tube.

Cowl and Propeller Installation

The cowl installation shown here is for the DLE-30 gas engine. Other installations are similar.



❑ 1. Connect the fuel lines to the engine. Connect an aluminum fuel line plug to the fill/drain line. Drill two 1/4" [6.4mm] holes at the bottom of the fiberglass sub-cowl and route the vent line and the fill line through these holes.

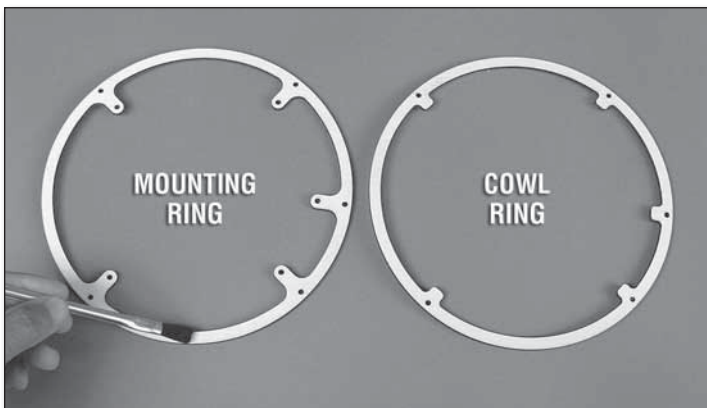

❑ 2. Mix up some 6-minute epoxy and thin it down with denatured alcohol. Brush this onto both sides of the two cowl rings to fuelproof them.

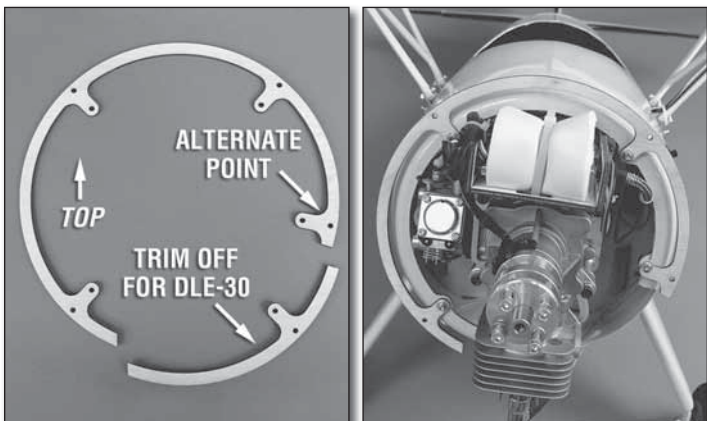

❑ 3. Install the cowl mounting ring to the fuselage using four 4-40 x 1/2" [12.7mm] SHCS, four #4 lock washers, and four #4 flat washers. Select the bolt holes based on the type of engine that you are using. For the gas engine, we had to trim

away the standard attachment point and use the alternate point. A typical glow engine installation should not require trimming of the cowl rings. Use a drop of thread locking compound on the screw threads.

❑ 4. Trim the cowl ring to match the mounting ring.

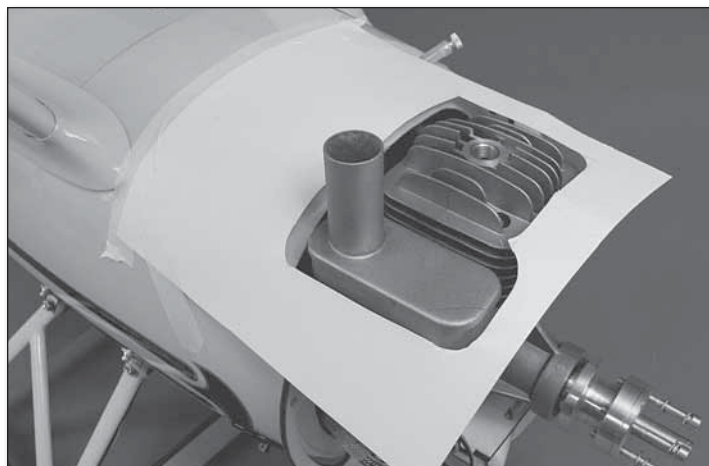

❑ 5. Cut pieces of card stock (old cereal boxes work well) and tape them to the fuselage side so that the trailing edge of the card stock is taped to the fuselage a few inches back from the cowl mounting ring. Trace the pattern of the head and muffler onto the card stock. Trim the card stock away a little at a time until you are satisfied with how it fits. This will be transferred to the cowl.

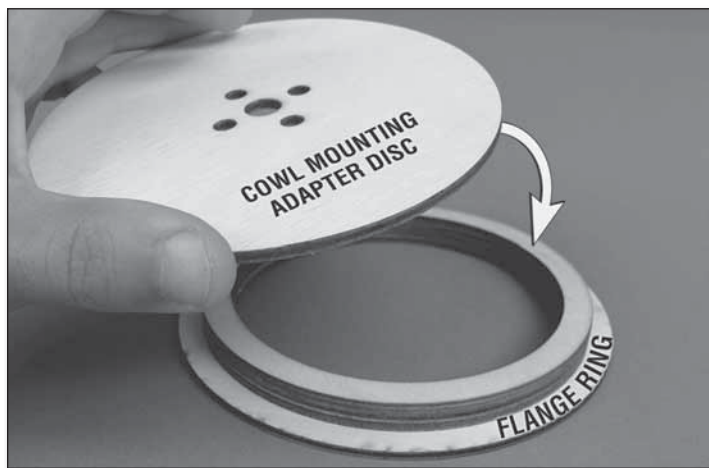

❑ 6. Assemble the cowl centering tool as shown. Glue the four 3mm thick plywood rings together. Then, glue those to the larger flange ring. Glue the mounting adapter disc to the top of the assembly. **Note:** The center hole of the mounting adapter disc is drilled for a 5/16" [7.9mm] crankshaft. Please use a 13/32" drill or a 10mm drill to enlarge the hole for the DLE-30 engine.

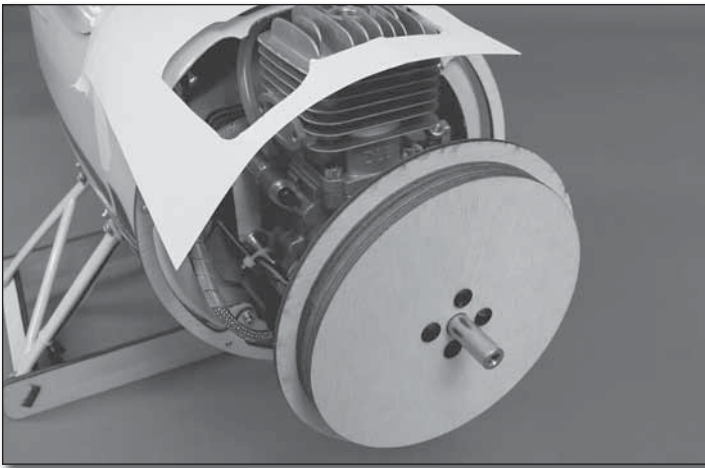

❑ 7. Remove the muffler. Fit the cowl centering tool to the engine as shown. Use four metric M4 x 20mm screws (not supplied) to hold the tool up against the drive washer of the engine. **Note:** The cowl will not sit flat against the cowl centering tool flange because of the right thrust in the engine, but you should push the cowl back until it is firmly seated on the flange of the tool.

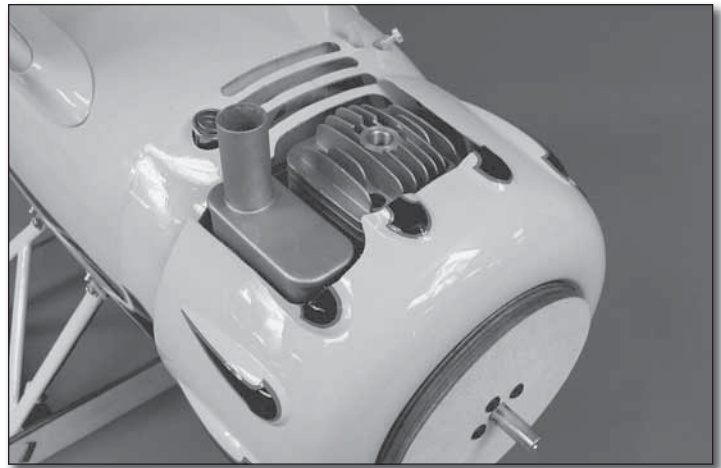

❑ 9. Remove the cowl and finish cutting access for the head and the muffler. Switch to a sanding drum to smooth the edges and radius the corners. Fit the muffler to the engine and test fit the cowl. Clean up any pen marks on the cowl with alcohol when you're finished.



❑ 8. Use a cutoff wheel on a Dremel® rotary tool and work on trimming the cowl away for the cylinder head. Be careful to align the cowl so that a pair of blisters points directly up. Placing a piece of masking tape on the cowl and the fuselage with an index mark on them will be helpful. Trim away material until the cowl is resting on the flange of the cowl center tool and there is sufficient clearance for the head. Then, lay the template over the top of the cowl and transfer the outline of the head and muffler cutout to the cowl. **Warning:** Wear a dust mask when cutting fiberglass parts. Cover up the spark plug hole with tape.

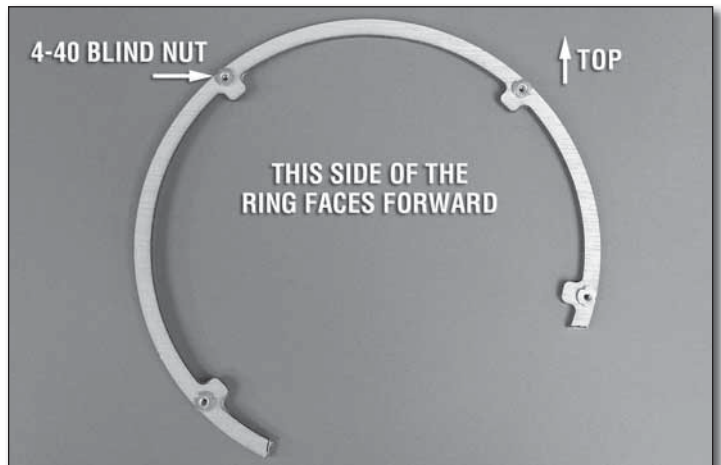

❑ 10. Install four blind nuts on the front side of the cowl mounting ring. Pay special attention to the orientation of the cowl ring so that you install the blind nuts on the correct side of the ring.

❑ 11. Cut a 16" x 16" [406mm x 406mm] piece of Great Planes Plan Protector film (GPMR6167) or some MonoKote backing film or plastic food wrap. Make a hole in the center of the film by making an "X" consisting of two 6" [152mm] slits. Sand the inside of the cowl where the mounting ring fits, using 150 grit sandpaper. Clean it with alcohol.



❑ 12. Fit the plan protector film over the aft cowl mounting ring. Mount the cowl ring to the aft mounting ring sandwiching the film between the two rings. Use four 4-40 x 1/2" [12.7mm] SHCS, four #4 lock washers, and four #4 flat washers to mount the cowl ring. Mix up a batch of 30-minute epoxy and add some milled fiberglass to it. Brush this onto the outer edge of the cowl ring. Fit the cowl over the cowl ring until it bottoms out on the cowl centering tool. **Note:** On the DLE-30, reinstalling the muffler will help ensure that the cowl is properly positioned.



❑ 13. When the epoxy is fully cured, remove the four screws holding the cowl in place and remove the cowl. Discard the plan protector film. Mix up another batch of epoxy and milled

fiberglass. Apply a continuous bead of this on the front side of the joint between the cowl and the ring. This will reinforce the cowl ring. **Note:** You may apply epoxy to the rear side of the cowl ring, but this must be a very thin layer without much of a fillet at the joint of the cowl to ring. Otherwise, this would interfere with the aft cowl ring.

❑ 14. Install the muffler and choke linkage (if applicable). Install the cowl and make any additional holes to access the needle valves. We set up a mechanical choke linkage by using a scrap piece of pushrod wire and a servo mounting grommet as a bushing in the cowl.

❑ 15. Trim the center of the dummy engine to clear the crankshaft of your engine. Cut away the open area between the dummy cylinders to allow cooling air to flow over the engine. Test fit the dummy engine in the cowl and then fit the cowl to the fuselage.

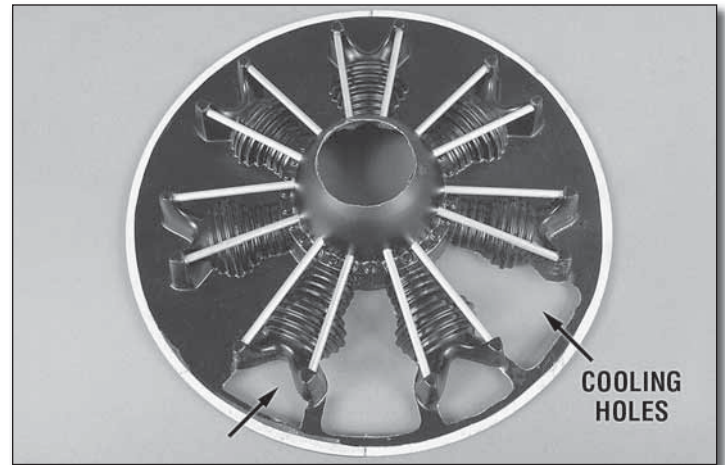

❑ 16. Pushrod tubes are included to help detail the dummy engine. Drill holes in the bottom of each rocker cover with a corresponding hole in the crankcase. Fit each tube and glue it in place from the inside with R/C-56 canopy glue.

❑ 17. Align the dummy cylinders with the cowl blisters and glue the dummy engine in place using R/C-56 glue or epoxy. Install the cowl using a drop of thread locking compound on the screw threads for added security.

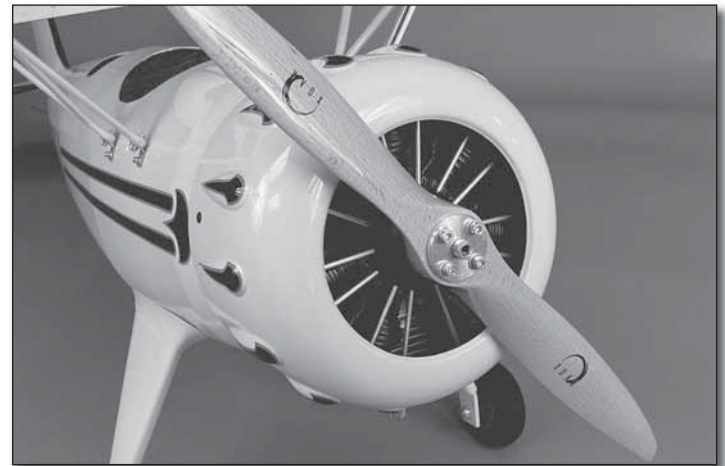

❑ 18. Install the prop and tighten the prop bolts or prop nut.

Install the Wheel Pants and Fairings



❑ 1. Install the left and right wheel pants using four 4-40x1/2" [12.7mm] SHCS, #4 lock washers, and four #4 flat washers.



❑ 2. Install the rear cockpit windscreen and the turtledeck fairing using R/C-56 canopy glue. Tape them in place until the glue cures. **Note:** You can poke pin holes through the covering to help improve adhesion.



❑ 3. Install the wing fillets using R/C-56 canopy glue.

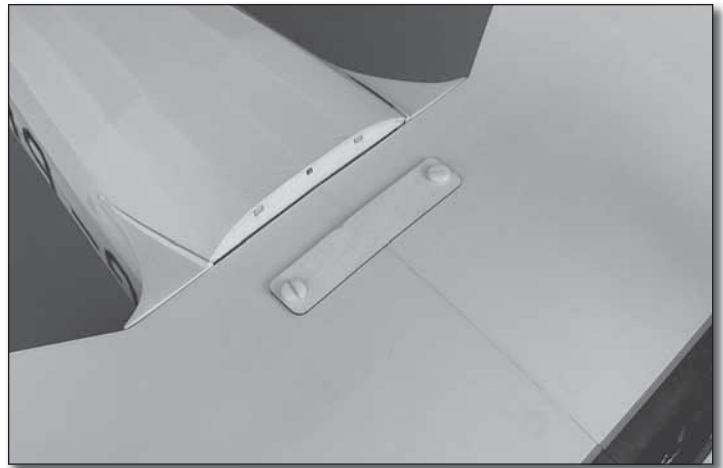

❑ 4. Using R/C-56, glue the wing bolt backing plate to the wing. Then, install the bottom wing using the two nylon wing bolts. Hold the top of the fillets in place up against the fuselage with tape until the glue dries.



❑ 5. Install the belly fairing to the bottom wing using R/C-56 canopy glue. Tape it in place while the glue dries.

Cockpit Options



Several options are available for you to finish your Waco YMF-5. The most commonly seen model was the double-cockpit, 3-passenger version. You can install the front windscreen and two more pilot figures in the front cockpit. A more unique option is the “mail plane” version. For this, you may fit the front cockpit cover. This version did not have a front windscreen.

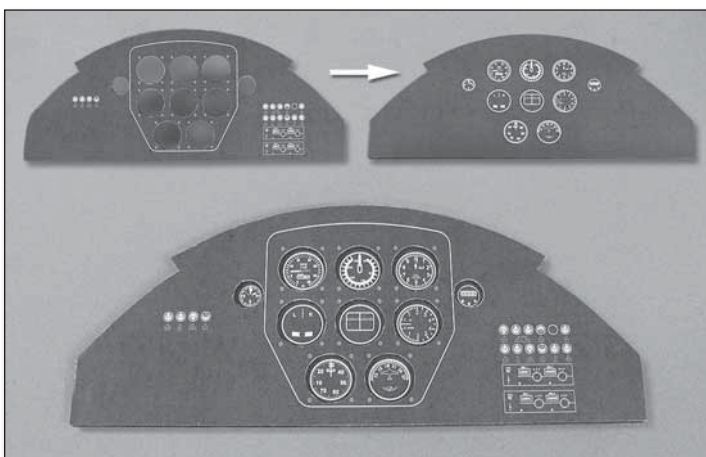

1. Identify the two rear instrument panel parts. The rear cockpit instrument panel is taller and is notched. Cut out the instrument decal and apply it to the solid instrument panel backing plate. Apply the outer decal to the faceplate. Glue the faceplate to the backing plate.

2. Fit the panel into the rear cockpit and glue it in place.

3. Prepare the front in the same way.

Pilot Installation (Optional)



1. To install a pilot figure, please purchase a Great Planes 1/5th scale pilot (GPMQ9115). Trim 3/8" off of the base of the pilot figure so the figure measures 4" for the rear pilot and 3-1/2" for the front.

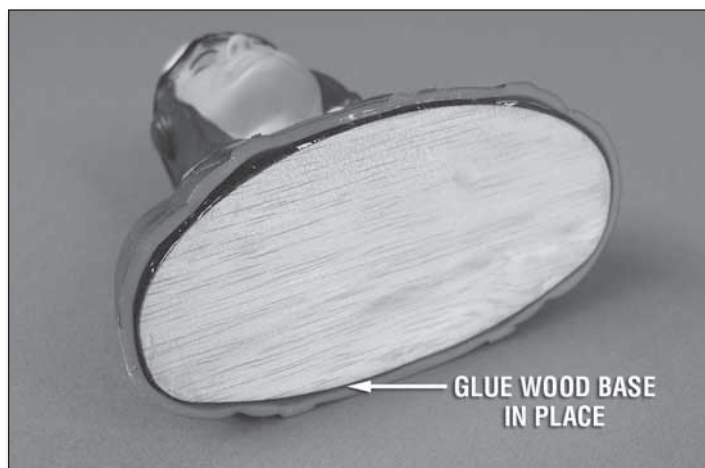

2. Clean the inner surface of the pilot figure with alcohol. Epoxy a wooden base to the bottom of the pilot. Let the epoxy cure.



3. Glue the pilot figure in place.

4. Repeat these steps to add a passenger (or two) to the front cockpit. **Note:** To install two passengers in the front, you will need to trim the left shoulder of the left passenger and the right shoulder of the right passenger.

Finishing the Model

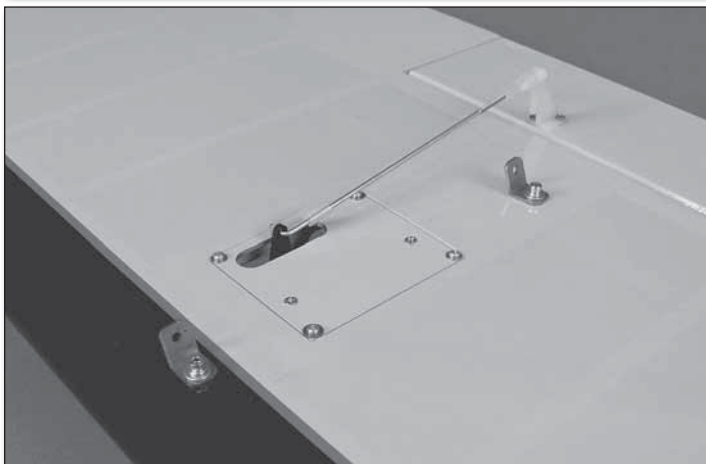
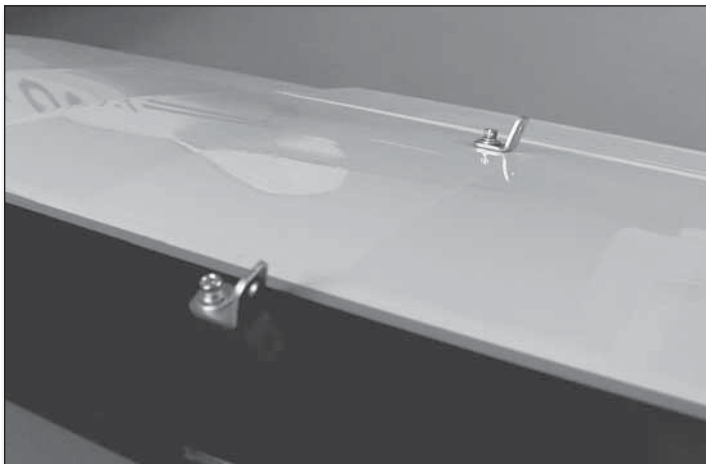

❑ 1. Install the eight 105° interplane strut brackets onto the wings using eight 4-40 x 1/2" [12.7mm] SHCS, eight #4 lock washers, and eight #4 flat washers. Install four brackets on the bottom side of the top wing and four on the top side of the bottom wing.



❑ 2. Remove the carrying handle from the cabane struts. Install the top wing onto the cabane struts using four 4-40x1/2" [12.7mm] SHCS, four #4 flat washers, and four #4 lock nuts.

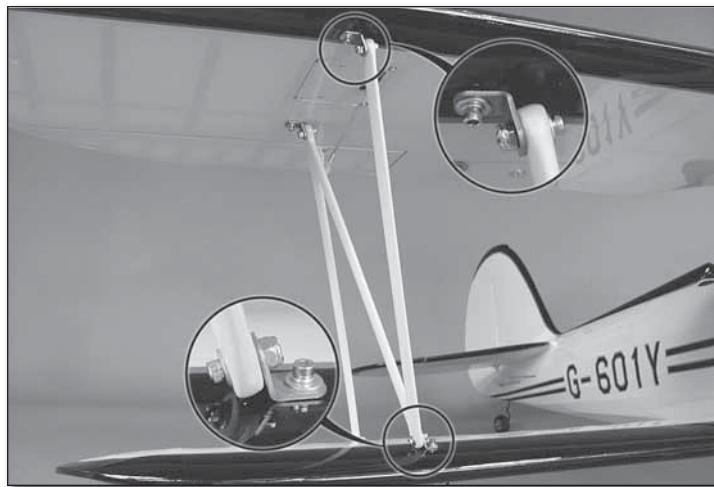

❑ 3. Install the two interplane struts using eight 4-40 x 1/2" [12.7mm] SHCS, eight #4 flat washers, and eight #4 lock nuts. **Note:** Be careful not to install the struts upside down. The bolt holes on bottom side of the struts are spread farther apart than the top (from front to back). You may have to loosen the screws attaching the brackets to the wings slightly to get everything to align properly, so be sure to re-tighten all of the screws when you're finished.



❑ 4. Connect the upper aileron servos to the Y-harness. Tuck the remaining wire into the hole in the upper wing.

Apply the Decals

- ❑ 1. Use scissors or a sharp hobby knife to cut the decals from the sheet.
- ❑ 2. Be certain the model is clean and free from oily fingerprints and dust. Prepare a dishpan or small bucket with a mixture of liquid dish soap and warm water—about one teaspoon of soap per gallon of water. Submerge the decal in the soap and water and peel off the paper backing. **Note:** Even though the decals have a “sticky-back” and are not the water transfer type, submersing them in soap & water allows accurate positioning and reduces air bubbles underneath.
- ❑ 3. Position decal on the model where desired. Holding the decal down, use a paper towel to wipe most of the water away.
- ❑ 4. Use a piece of soft balsa or something similar to squeegee remaining water from under the decal. Apply the rest of the decals the same way.
- ❑ 5. Use the templates in the back of this manual to make outlines for the passenger and cargo hatch doors.

GET THE MODEL READY TO FLY

Check the Control Directions

- ❑ 1. Turn on the transmitter and receiver and center the trims. If necessary, remove the servo arms from the servos and reposition them so they are centered. Reinstall the screws that hold on the servo arms.
- ❑ 2. With the transmitter and receiver still on, check all the control surfaces to see if they are centered. If necessary, adjust the clevises on the pushrods to center the control surfaces.

4-CHANNEL RADIO SET UP (STANDARD MODE 2)

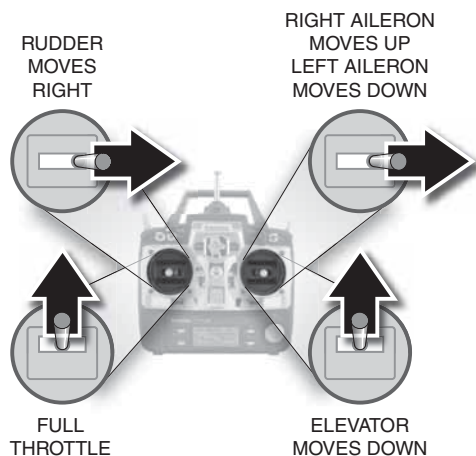

- ❑ 3. Make certain that the control surfaces and the carburetor respond in the correct direction as shown in the diagram. If any of the controls respond in the wrong direction, use the servo reversing in the transmitter to reverse the servos connected to those controls. Be certain the control surfaces have remained centered. Adjust if necessary.

Set the Control Throws

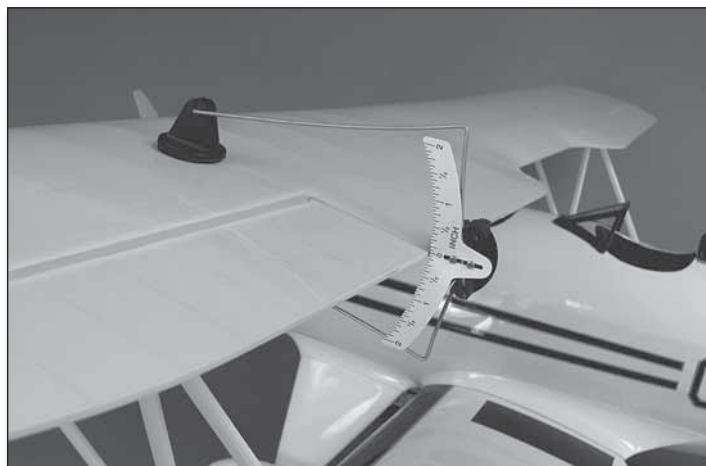

Use a Great Planes AccuThrow, a ruler, or an inclinometer to accurately measure and set the control throw of each control surface as indicated in the chart that follows. While more control throw is possible and may seem necessary, this model reacts well to very little throw. For this particular airplane, we recommend using the high rate rudder only on the ground when taxiing. Switch to low rate rudder before initiating your takeoff roll. **NOTE:** The throws are measured at the widest part of the elevators, rudder and ailerons.

These are the recommended control surface throws:

	HIGH RATE		LOW RATE	
	Up	Down	Up	Down
ELEVATOR	1-1/4" [32mm] 14°	1-1/4" [32mm] 14°	11/16" [17mm] 8°	11/16" [17mm] 8°
RUDDER	2-1/4" [57mm] 22°	2-1/4" [57mm] 22°	1-3/4" [44mm] 17°	1-3/4" [44mm] 17°
AILERONS	7/8" [22mm] 18°	7/8" [22mm] 18°	11/16" [17mm] 14°	11/16" [17mm] 14°

Balance the Model (C.G.)

At this stage the model should be in ready-to-fly condition with all of the systems in place including the prop, cowl, and pilot figure(s).



❑ 1. Use a felt-tip pen or 1/8" [3mm]-wide tape to accurately mark the C.G. on the bottom of the top wing on both sides of the fuselage. The C.G. is located 5-1/4" [133mm] back from the leading edge of the wing. **Note:** It is permissible to fly the airplane with the C.G. up to 7/16" [11.1mm] forward or 5/8" [15.9mm] aft of this mark, but for the first flights set the C.G. for the recommended location. Do not fly outside of the listed C.G. range!

To ensure a successful first flight, fly your Waco YMF-5 set up only according to the C.G. and control surface throws specified in this manual. The throws and C.G. are not arbitrary, but have been determined through extensive testing and accurate record-keeping. This provides you with the best chance for success and enjoyable first flights that should be surprise-free. Additionally, the throws and C.G. shown are true, real data which will allow the model to perform in the manner in which it was intended when flown by a pilot of the skill level for which it was intended. **DO NOT OVERLOOK THESE IMPORTANT PROCEDURES.** A model that is not properly setup will be dangerous, unstable, and possibly unflyable.



❑ 2. With all parts of the model installed (ready to fly) and an empty fuel tank, put your fingers on the balance points you just marked and suspend the model from these points.

❑ 3. If the tail drops, the model is "tail heavy" and the battery pack and/or receiver must be shifted forward or weight must be added to the nose to balance. If the nose drops, the model is "nose heavy" and the battery pack and/or receiver must be shifted aft or weight must be added to the tail to balance. If possible, relocate the battery pack and receiver to minimize or eliminate any additional ballast required. If additional weight is required, nose weight may be easily added by using a "spinner weight" (GPMQ4645 for the 1 oz. [28g] weight, or GPMQ4646 for the 2 oz. [57g] weight) if using a glow engine. If spinner weight is not practical or is not enough, use Great Planes (GPMQ4485) "stick on" lead. A good place to add stick-on nose weight is to the structure around the firewall (don't attach weight to the cowl—it is not intended to support weight). Begin by placing incrementally increasing amounts of weight on the bottom of the fuse over the firewall until the model balances. Once you have determined the amount of weight required, it can be permanently attached. If required, tail weight may be added by cutting open the bottom of the fuse and gluing it permanently inside.

Note: Do not rely upon the adhesive on the back of the lead weight to permanently hold it in place. Over time, fuel and exhaust residue may soften the adhesive and cause the weight to fall off. Use #2 sheet-metal screws or epoxy to permanently hold the weight in place.

❑ 4. **IMPORTANT:** If you found it necessary to add any weight, recheck the C.G. after the weight has been installed.

Balance the Model Laterally

❑ 1. With the wings level, have an assistant help you lift the model by the engine propeller shaft and the bottom of the fuse under the TE of the fin. Do this several times.

❑ 2. If one wing always drops when you lift the model, it means that side is heavy. Balance the airplane by adding weight to the other wing tip. An airplane that has been laterally balanced will track better in loops and other maneuvers.

PREFLIGHT

Identify Your Model

No matter if you fly at an AMA sanctioned R/C club site or if you fly somewhere on your own, you should always have your name, address, telephone number and AMA number on or inside your model. It is required at all AMA R/C club flying sites and AMA sanctioned flying events. Fill out the identification tag on page 39 and place it on or inside your model.

Charge the Radio Batteries

Follow the battery charging instructions that came with your radio control system to charge the batteries. You should always charge your transmitter and receiver batteries the night before you go flying, and at other times as recommended by the radio manufacturer.

CAUTION: Unless the instructions that came with your radio system state differently, the initial charge on new transmitter and receiver batteries should be done for 15 hours using the slow-charger that came with the radio system. This will "condition" the batteries so that the next charge may be done using the fast-charger of your choice. If the initial charge is done with a fast-charger the batteries may not reach their full capacity and you may be flying with batteries that are only partially charged.

Balance Propellers

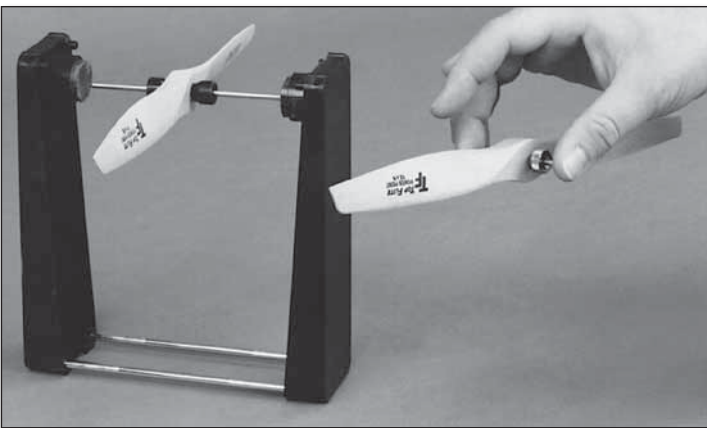

Carefully balance your propeller and spare propellers before you fly. An unbalanced prop can be the single most significant cause of vibration that can damage your model. Not only will engine mounting screws and bolts loosen, possibly with disastrous effect, but vibration may also damage your radio receiver and battery. Vibration can also cause your fuel to foam, which will, in turn, cause your engine to run hot or quit.

We use a Top Flite Precision Magnetic Prop Balancer (TOPQ5700) in the workshop and keep a Great Planes Fingertip Prop Balancer (GPMQ5000) in our flight box.

Ground Check and Range Check

Run the engine for a few minutes to make sure it idles reliably, transitions smoothly and maintains full power continuously. Afterward, shut the engine off and inspect the model closely, making sure all fasteners, pushrods and connections have remained tight and the hinges are secure. Always ground check the operational range of your radio before the first flight of the day following the manufacturer's instructions that came with your radio. This should be done once with the engine / motor off and once with the engine / motor running at various speeds. If the control surfaces do not respond correctly, do not fly! Find and correct the problem first. Look for loose servo connections or broken wires, corroded wires on old servo connectors, poor solder joints in your battery pack or a defective cell, or a damaged receiver crystal from a previous crash.

ENGINE SAFETY PRECAUTIONS

Failure to follow these safety precautions may result in severe injury to yourself and others.

- Keep all engine fuel in a safe place, away from high heat, sparks or flames, as fuel is very flammable. Do not smoke near the engine or fuel; and remember that engine exhaust gives off a great deal of deadly carbon monoxide. Therefore **do not run the engine in a closed room or garage.**
- Get help from an experienced pilot when learning to operate engines.
- Use safety glasses when starting or running engines.
- Do not run the engine in an area of loose gravel or sand; the propeller may throw such material in your face or eyes.
- Keep your face and body as well as all spectators away from the plane of rotation of the propeller as you start and run the engine.
- Use a "chicken stick" or electric starter to start the engine. Do not use your fingers to flip the propeller. Make certain the glow plug clip or connector is secure so that it will not pop off or otherwise get into the running propeller.
- Make all engine adjustments from behind the rotating propeller.
- The engine gets hot! Do not touch it during or right after operation. Make sure fuel lines are in good condition so fuel will not leak onto a hot engine, causing a fire.
- To stop a glow engine, cut off the fuel supply by closing off the fuel line or following the engine manufacturer's recommendations. Do not use hands, fingers or any other body part to try to stop the engine. To stop a gasoline powered engine an on/off switch should be connected to the engine coil or igniter unit. Do not throw anything into the propeller of a running engine or motor.

AMA SAFETY CODE (EXCERPTS)

Read and abide by the following excerpts from the Academy of Model Aeronautics Safety Code. For the complete Safety Code refer to Model Aviation magazine, the AMA web site or the Code that came with your AMA license.

General

1) I will not fly my model aircraft in sanctioned events, air shows, or model flying demonstrations until it has been proven to be airworthy by having been previously, successfully flight tested.

2) I will not fly my model aircraft higher than approximately 400 feet within 3 miles of an airport without notifying the airport operator. I will give right-of-way and avoid flying in the proximity of full-scale aircraft. Where necessary, an observer shall be utilized to supervise flying to avoid having models fly in the proximity of full-scale aircraft.

3) Where established, I will abide by the safety rules for the flying site I use, and I will not willfully and deliberately fly my models in a careless, reckless and/or dangerous manner.

5) I will not fly my model unless it is identified with my name and address or AMA number, on or in the model. **Note:** This does not apply to models while being flown indoors.

7) I will not operate models with pyrotechnics (any device that explodes, burns, or propels a projectile of any kind).

Radio Control

1) I will have completed a successful radio equipment ground check before the first flight of a new or repaired model.

2) I will not fly my model aircraft in the presence of spectators until I become a qualified flier, unless assisted by an experienced helper.

3) At all flying sites a straight or curved line(s) must be established in front of which all flying takes place with the other side for spectators. Only personnel involved with flying the aircraft are allowed at or in the front of the flight line. Intentional flying behind the flight line is prohibited.

4) I will operate my model using only radio control frequencies currently allowed by the Federal Communications Commission.

5) **I will not knowingly operate my model within three miles of any pre-existing flying site except in accordance with the frequency sharing agreement listed [in the complete AMA Safety Code].**

9) Under no circumstances may a pilot or other person touch a powered model in flight; **nor should any part of the model other than the landing gear, intentionally touch the ground, except while landing.**

CHECK LIST

During the last few moments of preparation your mind may be elsewhere anticipating the excitement of the first flight. Because of this, you may be more likely to overlook certain checks and procedures that should be performed before the model is flown. To help avoid this, a check list is provided to make sure these important areas are not overlooked. Many are covered in the instruction manual, so where appropriate, refer to the manual for complete instructions. Be sure to check the items off as they are completed.

- 1. Fuelproof all areas exposed to fuel or exhaust residue such as the cowl mounting blocks, wing saddle area, etc.
- 2. Check the C.G. according to the measurements provided in the manual.
- 3. Be certain the battery and receiver are securely mounted in the fuse. Simply stuffing them into place with foam rubber is not sufficient.
- 4. Extend your receiver antenna and make sure it has a strain relief inside the fuselage to keep tension off the solder joint inside the receiver.
- 5. Balance your model *laterally* as explained in the instructions.
- 6. Use threadlocking compound to secure critical fasteners such as the set screws that hold the wheel axles to the struts, screws that hold the carburetor arm (if applicable), screw-lock pushrod connectors, etc.
- 7. Add a drop of oil to the axles so the wheels will turn freely.
- 8. Make sure all hinges are **securely** glued in place.
- 9. Reinforce holes for wood screws with thin CA where appropriate (servo mounting screws, cowl mounting screws, etc.).
- 10. Confirm that all controls operate in the correct direction and the throws are set up according to the manual.
- 11. Set up and check a throttle cutoff on your radio.
- 12. Make sure there are silicone retainers on all the clevises and that all servo arms are secured to the servos with the screws included with your radio.
- 13. Tighten all jam nuts against the threaded clevises on your control surfaces.
- 14. Secure connections between servo wires and Y-connectors or servo extensions, and the connection between your battery pack(s) and the on/off switch with vinyl tape, heat shrink tubing or special clips suitable for that purpose.
- 15. Make sure any servo extension cords you may have used do not interfere with other systems (servo arms, pushrods, etc.).
- 16. Secure the pressure tap (if used) to the muffler with high temp RTV silicone, thread-locking compound or J.B. Weld.
- 17. Make sure the fuel lines are connected and are not kinked.
- 18. Balance your propeller (and spare propellers).
- 19. Tighten the propeller nut or prop bolts.
- 20. Place your name, address, AMA number and telephone number on or inside your model.

- ❑ 21. Cycle your receiver battery pack (if necessary) and make sure it is fully charged.
- ❑ 22. Range-check your radio at the field at the start of each flying day. Check it with the engine operating.

FLYING

The Waco YMF-5 is a great-flying model that flies smoothly and predictably. The Waco YMF-5 does not, however, possess the self-recovery characteristics of a primary R/C trainer and should be flown only by experienced R/C pilots.

Fuel Mixture Adjustments

A fully cowled engine may run at a higher temperature than an un-cowled engine. For this reason, the fuel mixture should be richened so the engine runs at about 200 rpm below peak speed. By running the engine slightly rich, you will help prevent dead-stick landings caused by overheating. Keep in mind also that an engine runs more rich on the ground. Leaning to peak rpm on the ground can cause overheating in the air.

CAUTION (THIS APPLIES TO ALL R/C AIRPLANES): If, while flying, you notice an alarming or unusual sound such as a low-pitched "buzz," this may indicate control surface flutter. Flutter occurs when a control surface (such as an aileron or elevator) or a flying surface (such as a wing or stab) rapidly vibrates up and down (thus causing the noise). In extreme cases, if not detected immediately, flutter can actually cause the control surface to detach or the flying surface to fail, thus causing loss of control followed by an impending crash. The best thing to do when flutter is detected is to slow the model immediately by reducing power, then land as soon as safely possible. Identify which surface fluttered (so the problem may be resolved) by checking all the servo grommets for deterioration or signs of vibration. Make certain all pushrod linkages are secure and free of play. If it fluttered once, under similar circumstances it will probably flutter again unless the problem is fixed. Some things which can cause flutter are; Excessive hinge gap; Not mounting control horns solidly; Poor fit of clevis pin in horn; Side-play of wire pushrods caused by large bends; Excessive free play in servo gears; Insecure servo mounting; and one of the most prevalent causes of flutter; Flying an over-powered model at excessive speeds.

Takeoff

Before you get ready to takeoff, see how the model handles on the ground by doing a few practice runs at low speeds on the runway. Hold "up" elevator to keep the tail wheel on the ground. If necessary, adjust the tail wheel so the model will roll straight down the runway. If you need to calm your nerves before the maiden flight, shut the engine down and bring the model back into the pits. Top off the fuel, then check all fasteners and control linkages.

Remember to takeoff into the wind. When you're ready, point the model straight down the runway, hold a bit of up elevator to keep the tail on the ground to maintain tail wheel steering, then gradually advance the throttle. As the model gains speed, decrease up elevator allowing the tail to come off the ground naturally. One of the most important things to remember with a tail dragger is to always be ready to apply right rudder to counteract engine torque. Gain as much speed as your runway and flying site will practically allow before gently applying up elevator, lifting the model into the air. At this moment it is likely that you will need to apply more right rudder to counteract engine torque. Be smooth on the elevator stick, allowing the model to establish a gentle climb to a safe altitude before turning into the traffic pattern.

Flight

For reassurance and to keep an eye on other traffic, it is a good idea to have an assistant on the flight line with you. Tell him to remind you to throttle back once the plane gets to a comfortable altitude. While full throttle is usually desirable for takeoff, most models fly more smoothly at reduced speeds.

Take it easy with your airplane for the first few flights, gradually getting acquainted with it as you gain confidence. Adjust the trims to maintain straight and level flight. After flying around for a while, and while still at a safe altitude with plenty of fuel, practice slow flight and execute practice landing approaches by reducing the throttle to see how the model handles at slower speeds. Make a few more runs minding your field's current traffic pattern and try executing a few straight-ahead stalls. Add power to see how she climbs as well. Continue to fly around, executing various maneuvers and making mental notes (or having your assistant write them down) of what trim or C.G. changes may be required to fine tune the model so it flies the way you like. Mind your fuel level or batteries, but use this first flight to become familiar with your model before landing.

Landing

To initiate a landing approach, lower the throttle while on the downwind leg. Allow the nose of the model to pitch downward to gradually bleed off altitude. Continue to lose altitude, but maintain airspeed by keeping the nose down as you turn onto the crosswind leg. Make your final turn toward the runway (into the wind) keeping the nose down to maintain airspeed and control. Level the attitude when the model reaches the runway threshold, modulating the throttle as necessary to maintain your glide path and airspeed. If you are going to overshoot, smoothly advance the throttle (always ready on the right rudder to counteract torque) and climb out to make another attempt. When you're ready to make your landing flare and the model is a foot or so off the deck, smoothly increase up elevator until it gently touches down. Once the model is on the runway and has lost flying speed, hold up elevator to place the tail on the ground, regaining tail wheel control.

One final note about flying your model. Have a goal or flight plan in mind for every flight. This can be learning a new maneuver(s), improving a maneuver(s) you already know, or learning how the model behaves in certain conditions (such as on high or low rates). This is not necessarily to improve your skills (though it is never a bad idea!), but more importantly so you do not surprise yourself by impulsively attempting a maneuver and suddenly finding that you've run out of time, altitude, or airspeed. Every maneuver should be deliberate, not impulsive. For example, if you're going to do a loop, check your altitude, mind the wind direction (anticipating rudder corrections that will be required to maintain heading), remember to throttle back at the top, and make certain you are on the desired rates (high/low rates). A flight plan greatly reduces the chances of crashing your model just because of poor planning and impulsive moves. Remember to think.

Have a ball!
But always stay in control and fly in a safe manner.

GOOD LUCK AND GREAT FLYING!

**IGNITION SWITCH AND ERNST
CHARGE JACK TEMPLATE**

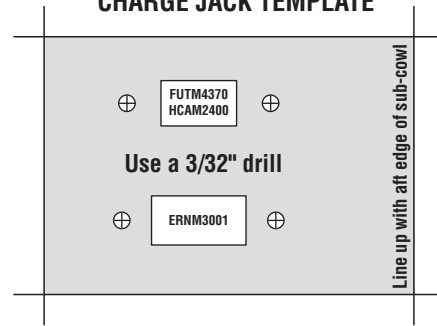

This model belongs to:

_____	_____	_____	_____	_____	_____
Name	Address	City	State	ZIP	AMA #

Copy (or cut out) this tag and put it in your model.

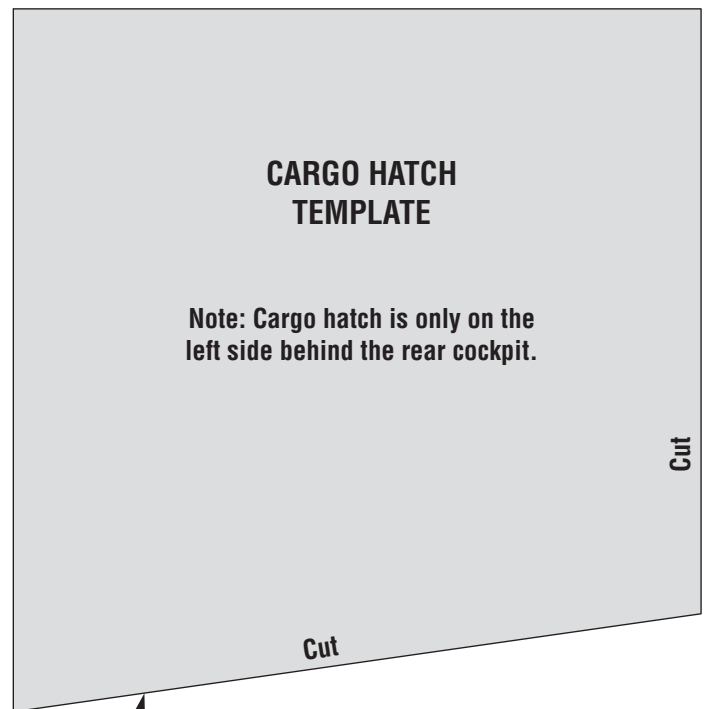
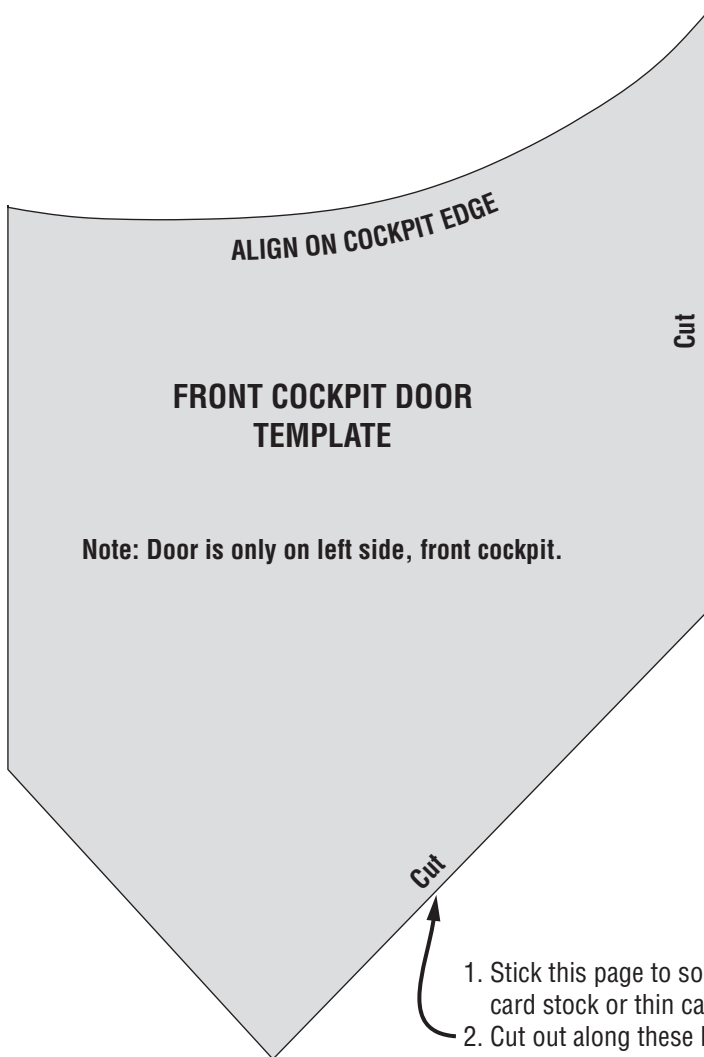

1. Stick this page to some card stock or thin cardboard.
2. Cut out along these lines.
3. Using the pictures on the box as a guide, Tape in place and trace panel lines onto fuselage using a Top Flite panel line pen.

